



Feasibility Study

Water Treatment Plant

City of Ramsey, Minnesota

RAMSY 154354 | March 4, 2021



Building a Better World
for All of Us®

Engineers | Architects | Planners | Scientists

Feasibility Study

Water Treatment Plant
City of Ramsey, Minnesota

SEH No. RAMSY 154354

March 4, 2021

I hereby certify that this report was prepared by me or under my direct supervision, and that I am a duly Licensed Professional Engineer under the laws of the State of Minnesota.

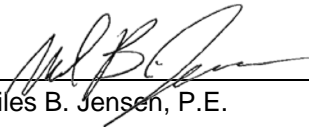

Miles B. Jensen, P.E.

Date: March 4, 2021

License No.: 19869

Short Elliott Hendrickson Inc.
3535 Vadnais Center Drive
St. Paul, MN 55110-3507
651.490.2000



Executive Summary

The City of Ramsey has eight water supply wells with concentrations of manganese ranging from 0.02 mg/L to 0.37 mg/L. The Minnesota Department of Health (MDH) has established a Health Based Value (HBV) for manganese of 0.100 mg/L. Four of Ramsey's eight water supply wells exceed the MDH HBV for manganese. MDH has recommended to the City that they develop plans to address the manganese. In addition to the potential health concerns with manganese, Ramsey's drinking water also exceeds the Secondary Standards for iron and manganese. Water with concentrations of iron and manganese above the Secondary Standard causes aesthetic problems including red and black staining of plumbing fixtures and laundry and taste complaints.

The City of Ramsey currently utilizes groundwater from the Tunnel City-Wonewoc (TCW) aquifer as its exclusive source of drinking water. An evaluation was conducted of the TCW aquifer which determined that the TCW should be able to continue to produce potable water to meet present and foreseeable future demands.

The most cost-effective method for removing manganese and iron from drinking water is chemical oxidation followed by sand filtration. These processes require construction of a water treatment plant. Based upon an analysis of Ramsey's 2040 water demand, the initial capacity of the water treatment plant should be 10 million gallons per day (MGD), with the ability to expand to 20 MGD.

Four water treatment plant sites were evaluated including the Fire Station site, Public Works site, Water Shop site, and Vacant City property site. The Public Works site would be the least expensive to construct because it could share garage space, a generator, and security infrastructure with the onsite Public Works facility. The Public Works site also offers operational efficiencies because it is on the same site as the new Public Works facility. In January of 2020, the City of Ramsey's Planning Commission, Economic Development Authority, and Public Works Committee all voted unanimously to recommend City Council approval to construct the water treatment plant on the Public Works site.

This study evaluated two treatment process alternatives including gravity filtration and pressure filtration. With gravity filtration, the water flows by gravity through concrete filter cells into a holding tank (clearwell). The water is then pumped into the distribution system. With pressure filtration, the water is pumped from the wells through steel pressure filters and directly into the distribution system.

Report level project and life cycle cost opinions for the two alternatives are included below. The project costs include the capital cost plus 10-percent contingency, 1-percent administration, and 12-percent engineering costs. Life cycle costs represent the total cost of owning and operating the water treatment plant for 50 years and include capital cost, equipment replacement, labor, gas, chemicals, insurance, electricity, and annual equipment repair.

	<u>Project Cost</u>	<u>50 Year Life Cycle Cost</u>
Gravity Filter Treatment Plant	\$32,400,000	\$71,880,000
Pressure Filter Treatment Plant	\$30,780,000	\$75,440,000

As the table indicates, the gravity filter treatment plant has a slightly higher project cost, but a lower overall life cycle cost. The pressure filter treatment plant has a higher life cycle cost due to the expense of painting and maintaining the steel filters; whereas concrete gravity filters require very little maintenance.

Executive Summary (continued)

In addition to having lower life cycle costs, gravity filters have other advantages over pressure filters including: (1) more treatment options including aeration and detention without requiring another pumping step, (2) water from the gravity filters does not go immediately into the distribution system so if problems occur with treatment processes operators have time to react, (3) gravity filters are open to view and access, and (4) gravity filtration systems have a greater amount of operational flexibility including the ability to treat surface water.

A gravity filter treatment plant is the recommended alternative due to the advantages it offers at a comparable cost.

If the City elects to proceed with a water treatment plant project, the proposed project schedule could be as follows:

<u>Item</u>	<u>Completion Date</u>
Public Involvement	March 2021 – April 2021
Preparation of Plans	May 2021 – September 2021
Ad for Bid	October 2021
Bid Opening	November 2021
Construction Start	December 2021
Construction Complete	June 2023

However, Anoka County is planning “interim” improvements to Bunker Lake Boulevard between Armstrong Boulevard and Sunfish Lake Boulevard in 2021 to improve operations and safety in anticipation of traffic volumes doubling while planned improvements to Highway 10 are constructed between 2022 and 2025. Therefore, to construct the raw and finished watermain associated with the water treatment plant project as cost-effectively as possible, plans and specifications for the raw and finished watermain improvements are recommended to be prepared and bid in conjunction with Anoka County’s proposed improvements to Bunker Lake Boulevard.

Operating the water treatment plant is not anticipated to require additional Staff. While Staff will need to visit the plant on a daily basis to operate and maintain it, this time will generally be offset by the time Staff currently spends operating and maintaining the six municipal wells and three pump houses within The COR.

If a water treatment plant project is pursued, immediate distribution water quality improvements should not be expected. The water treatment plant will produce water free of iron and manganese; however, it takes time for the iron and manganese deposits in the distribution system to dissipate and overall water quality to improve.

Contents

Certification Page
Executive Summary
Contents

1	Existing Water Infrastructure	1
1.1	Overall System Description	1
1.2	Raw Water Supply	1
1.3	Current Water Treatment	2
1.4	Existing Water Towers	3
2	Distribution System Modeling	3
2.1	Existing System Static Pressures	4
2.2	Existing System 24-Hour Simulation	5
2.3	Existing System Available Flow for Fire Protection	6
2.4	Existing System 24-Hour Simulation – Treatment Plant	7
2.5	2040 System 24-Hour Simulation	8
2.6	Distribution Modeling Conclusions and Recommendations	8
3	Drinking Water Quality	9
3.1	Primary Drinking Water Standards	9
3.2	Manganese	10
3.3	Secondary Drinking Water Standards	11
3.4	Emerging Contaminants	12
4	Water Demand	13
4.1	Adequacy of Existing Water Supply	13
5	Groundwater Availability	14
5.1	Description of the Hydrogeological Setting	14
5.2	Groundwater Modeling Conclusions	24
6	Regional Water Supply Study	25
7	Water Treatment	26
7.1	Current and Future Treatment Needs	27
7.2	Treatment Capacity	27
7.3	Manganese and Iron Removal Options	27
7.4	Hardness Removal	28

Contents (continued)

7.5	Pilot Study Results	29
7.6	Filter Sizing.....	29
7.7	Operator Input	29
7.8	Treatment Alternative 1 - Gravity Filter Layout.....	29
7.9	Treatment Alternative 2 – Pressure Filter Layout	32
7.10	Backwash Alternatives	33
8	Architectural Design	35
9	Utility Space Needs Evaluation	35
10	Water Treatment Plant Site Alternatives and Evaluation	35
10.1	Fire Station Site	35
10.2	Public Work Site	36
10.3	Water Shop Site	37
10.4	Vacant City Property Site	38
10.5	Water Treatment Plant Site Evaluation and Recommendation.....	38
11	Impacts to Nearby Properties.....	39
12	Capital Cost Opinions	39
13	Life Cycle Cost Opinions.....	40
14	Alternative Evaluation & Recommendation	41
15	Funding	42
15.1	Drinking Water Revolving Fund Loan	42
15.2	Grants.....	42
16	Effect on Water Rates	43
17	Public Involvement	43
18	Schedule	43

Contents (continued)

List of Tables

Table 1 – Well Data.....	2
Table 2 – Hydrant Flow Test Results	3
Table 3 – Water System Static Pressures.....	5
Table 4 – Minimum Fire Flows	7
Table 5 – Water Quality - Primary Drinking Water Standards	10
Table 6 – Manganese in Ramsey Wells.....	11
Table 7 – Iron and Hardness in Ramsey Wells	11
Table 8 – Projected Water Demands	13
Table 9 – Bedrock Aquifers	15
Table 10 – Ramsey Well Data.....	16
Table 11 – Drawdown in Ramsey Wells.....	20
Table 12 – Fire Station Site Costs.....	36
Table 13 – Public Works Site Costs	37
Table 14 – Water Shop Site Costs	37
Table 15 – Vacant City Property Site Costs	38
Table 16 – Alternate Site Cost Comparison	39
Table 17 – Capital Cost Opinion Summary Gravity Filter Water Treatment Plant	40
Table 18 – Capital Cost Opinion Summary Pressure Filter Water Treatment Plant .	40
Table 19 – 50-Year Life Cycle Cost Summary Gravity Filter Water Treatment Plant	41
Table 20 – 50-Year Life Cycle Cost Summary Pressure Filter Water Treatment Plant	41

List of Figures

Figure 1 – ADD Diurnal Curve.....	6
Figure 2 – MDD Diurnal Curve	6
Figure 3 – Terms Relating to Well Performance	18
Figure 4 – Well 5 Drawdown and Recharge.....	19
Figure 5 – Drawdown in Observation Well 8	22

Contents (continued)

List of Appendices

Appendix A	Existing Water System Map
Appendix B	Modeling
Appendix C	CCL
Appendix D	Groundwater Modeling Memo
Appendix E	Pilot Study
Appendix F	Gravity Filter Layouts
Appendix G	Pressure Filter Layouts
Appendix H	Architectural Renderings
Appendix I	Treatment Plant Sites and Raw Watermain
Appendix J	Capital Cost Opinions
Appendix K	Life Cycle Cost Opinions

Feasibility Study

Water Treatment Plant

Prepared for City of Ramsey

1 Existing Water Infrastructure

1.1 Overall System Description

The City of Ramsey's water system dates back to 1985 when a well, pressure tank storage, and distribution piping was constructed. Today, Ramsey's water system provides drinking water to approximately 4,400 residences and approximately 340 businesses. The existing water system consists of the following major components:

- Eight municipal wells
- Four pump houses
- Chemical feed systems in each pump house to add chlorine, fluoride, and polyphosphate
- Over 83 miles of watermain
- Over 900 fire hydrants
- Three water towers with a combined storage of 4 million gallons (MG)

The wells pump water to their respective pump houses, with Wells No. 1 and 2 pumping to Pump House 1, Wells No. 3 and 4 pumping to Pump House 2, Wells No. 5 and 6 pumping to Pump House 3, and Wells No. 7 and 8 pumping to Pump House 4. Following chemical addition at the Pump Houses, water is pumped directly into the distribution system.

1.2 Raw Water Supply

The City of Ramsey operates eight (8) municipal wells finished in the Tunnel City-Wonewoc (TWC) aquifer. Table 1 provides a summary of each well. Figure 1 in Appendix A shows the Ramsey distribution system map that identifies the locations of the wells, as well as the towers.

Table 1 – Well Data

Well No.	Year Constructed	Formation	Depth	Casing Depth (ft)	Casing Size (in)	Capacity (gpm)
1	1984	Ironton-Galesville	320	243	14	700
2	1987	Ironton-Galesville	320	240	14	220
3	1997	Ironton-Galesville	345	222	30	1,450
4	1998	Ironton-Galesville	321	191	30	850
5	2000	Ironton-Galesville	316	215	30	850
6	2005	Ironton-Galesville	390	282	30	900
7	2007	Ironton-Galesville	332	216	30	850
8	2007	Ironton-Galesville	354	245	30	1,400

Notes: Well No. 2 used exclusively for irrigation of River's Bend Park.

The combined capacity of all of the wells is 7,220 gallons per minute (gpm) which is equivalent to 10.4 million gallons per day (MGD). The firm capacity (capacity with the largest well out of service) is 5,770 gpm or 8.3 MGD.

If a centralized water treatment plant is constructed, Wells No. 1 and 2 would not initially be connected to the water treatment plant due to the significant expense required to extend trunk watermain to the water treatment plant. The firm capacity without considering Wells No. 1 and 2 is 4,850 gpm or 7.0 MGD.

All of the wells are located in the southern part of the City north of U.S. Highway 10, with Wells No. 1 and 2 located in the south-eastern portion of Ramsey, and Wells No. 3 through 8 located in the south-central portion of Ramsey.

Maintenance records indicate that the wells, pumps, and motors are inspected and repaired on a routine basis. The condition of the wells, pumps, and motors system-wide appears to be good.

1.3 Current Water Treatment

Chlorine is added to the well water to provide a disinfectant residual in the distribution system. The City utilizes a free chlorine residual in the distribution system rather than chloramine, which is a less powerful disinfecting agent created when chlorine is mixed with ammonia. The City does have low levels of naturally occurring ammonia in their well water, although chlorine is fed past the breakpoint to completely oxidize the ammonia.

Polyphosphate is added to the water to sequester iron and manganese. Sequestering of iron and manganese keeps the metals in solution and prevents them from precipitating to form oxides, and thus preventing aesthetic water quality issues such as color, taste, and sedimentation. Sequestration does not remove iron or manganese, and polyphosphate degrades over time which may cause aesthetic issues at dead-ends and outer ends of the distribution system.

In accordance with Minnesota State Statute, fluoride is also added to the treatment process to promote strong teeth.

The chemicals are added to the raw water from the wells in each of the pump houses prior to being pumped into the distribution system.

1.4 Existing Water Towers

The City of Ramsey currently has three water towers with storage capacities of 0.5 MG (tower 1), 1.5 MG (tower 2), and 2.0 MG (tower 3). Towers 1 and 2 are located in the south-eastern and south-central parts of the City respectively, while tower 3 is located in the north-eastern part of the City. The 0.5 MG tower is a spheroid style steel water tower constructed in 1989, while the 1.5 MG and 2.0 MG towers are fluted column steel water towers constructed in 2000 and 2010, respectively.

2 Distribution System Modeling

A hydraulic computer model was generated to evaluate the performance of the City's current water distribution system, as well as evaluate the system into the future as the water system expands, experiences increasing demands, and utilizes a water treatment plant instead of individual wells pumping into the system. The model used the most recent GIS information for the City's water system assets, and was created using WaterGEMS®, a pipe network program developed by Bentley®. Flow testing was conducted within the distribution system in October 2019 to calibrate and help verify the accuracy of the computer model. A summary of the flow test results and locations are listed in Table 2.

The water model allows the water system to be examined, while adding proposed features to the system. This provides an indication as to what pressures and flows would be available in the water system with the various proposed features. The model also allows for the examination of component operation within the system such as water tank filling cycles. There are many other exercises that the model can be used for in the future in relation to water system operations and planning. The water model can continue to be an operations and planning tool for the expanding water system.

Table 2 – Hydrant Flow Test Results

Flow Test	Location	Field Hydrant Flow (gpm)	Pressure Differential Field Results (psi)	Pressure Differential Model Results (psi)	Pressure Differential (psi)
1	Olivine St. NW south off of 147 th Ln. NW	1,171	2	1	-1
2	Dead-end on Vanadium St. NW	1,123	4	2	-2
3	Dead-end on 140 th Ave. NW	1,205	8	10	2
4	Dead-end on 142 nd Ln. NW	984	26	42	16
5	Corner of Tonto St. NW and Alpine Dr. NW	1,188	4	6	2
6	Dead-end on 152 nd Ave. NW	1,047	9	7	-2
7	Corner of 157 th Ave. NW and Krypton St. NW	1,152	7	9	2
8	Dead-end on Lithium St. NW	1,047	7	8	1
9	Dead-end of east end of 167 th Ln. NW	1,197	4	2	-2
10	Dead-end of new cul-de-sac off of 159 th Ave. NW	1,078	6	7	1

Flow Test	Location	Field Hydrant Flow (gpm)	Pressure Differential Field Results (psi)	Pressure Differential Model Results (psi)	Pressure Differential (psi)
11	Current dead-end on 149 th Ave. NW	1,234	5	5	0
12	West dead-end on 147 th Ln. NW	1,123	3	8	5
13	Dead-end on 137 th Ave. NW	1,188	11	10	-1
14	East dead-end on Rivlyn Ave. NW	1,031	10	10	0

During the calibration process of the Ramsey water system hydraulic model, pumping rates, customer demands, and tower water levels were set to the conditions recorded during the field testing. Individual pipe roughness coefficients (C-factors) were adjusted until the calibrated system model closely simulated field test data as indicated in Table 2. As indicated from Tests 4 and 12, the model was unable to be calibrated to match the field tests. For Test 4, it is believed there was an error when measuring during the field test. The age and size of the pipe on 142nd Ln. NW is the same as the pipe on 140th Ave. NW (Test 3), which the model calibrated closely with. It is believed that the pipe roughness coefficient used for the pipe on 142nd Ln. NW is accurate. For Test 12, it is believed that there is another pipe off of Bunker Lake Blvd. that connects to the new development along 147th Ln. NW that is not yet geo-located, because when adding an additional pipe, the model calibrates closely with the field data. The pipe along 147th Ln. NW is a new 8" pipe, so it is believed that the pipe roughness coefficient used for the pipe is accurate. Additionally, Test 10 was conducted on hydrants in a new development. Previously, this area was at a lower elevation than it is currently. This caused the model to not correlate well with the field-testing data. The elevations of the hydrants in the model were adjusted to more closely correlate with the field data, and as the pipe in the development is new, it is believed that the pipe roughness coefficient used for the pipe is accurate.

Once the computer water model was constructed and calibrated, the model was used to calculate the operating conditions in the water distribution system.

2.1 Existing System Static Pressures

Water system pressure is primarily a function of elevation with some degree of pressure loss as water flows across the system. Static pressures throughout the distribution system as determined by the water model are shown in Figures 1-3 in Appendix B for average day demand (ADD), maximum day demand (MDD), and Peak Hour Demand. Low pressures generally occur in areas where the elevations are relatively high compared to the overflow elevation or hydraulic grade line (HGL) of the system.

As you can see in Figures 1-3 in Appendix B, the pressures across the system are generally consistent, and are approximately the same between the three demand scenarios. All areas of the system are within the range of 50 to 80 psi as you can see in Table 3.

Table 3 – Water System Static Pressures

	Average Day Demand	Maximum Day Demand	Peak Hour Demand
Minimum Pressure (psi)	56	56	56
Average Pressure (psi)	68.5	68.1	67.5
Maximum Pressure (psi)	77	77	76
Demand (gpm)	1,221	3,330	5,498

All three demand scenarios were done with the towers at an HGL of 1,031 feet. No wells were running during the model simulation.

2.2 Existing System 24-Hour Simulation

A 24-hour extended period simulation was run for average day demand (ADD) and maximum day demand MDD to model how the existing system performs in terms of pressure, velocity, and tank levels. System pressures are recommended to be in the range of 35 psi to 80 psi, and pipe velocities are recommended to not exceed 5 feet per second. For an average day demand, 1.72 MGD was assumed, and for maximum day demand, a maximum day peaking factor of 2.73 was assumed to get a maximum day demand of 4.7 MGD. For both demand scenarios, diurnal demand curves were used, and were developed by analyzing SCADA operation data documenting system water tower levels, as well as using industry standards and previous experience. These diurnal demand curves are shown in Figures 1 and 2 and were used for all modeling simulations. The operating range of Tower 1 was assumed to be 6 feet where wells would initially turn on when the HGL of Tower 1 went below 1,025 feet, and the wells would turn off when the HGL of Tower 1 went above 1,031 feet. Figures 4-5 in Appendix B show the operation of the wells and towers for both demand scenarios.

The pressures across the system were generally consistent throughout the 24-hour simulation for both demand scenarios. As can be seen in Figures 6-7 in Appendix B, at no point did pressures drop below 50 psi, and at no point did pipe velocities exceed 3 feet per second for the ADD simulation or exceed 5 feet per second for the MDD simulation. In fact, only one segment of pipe exceeded 4 feet per second during the MDD simulation.

Figure 1 – ADD Diurnal Curve

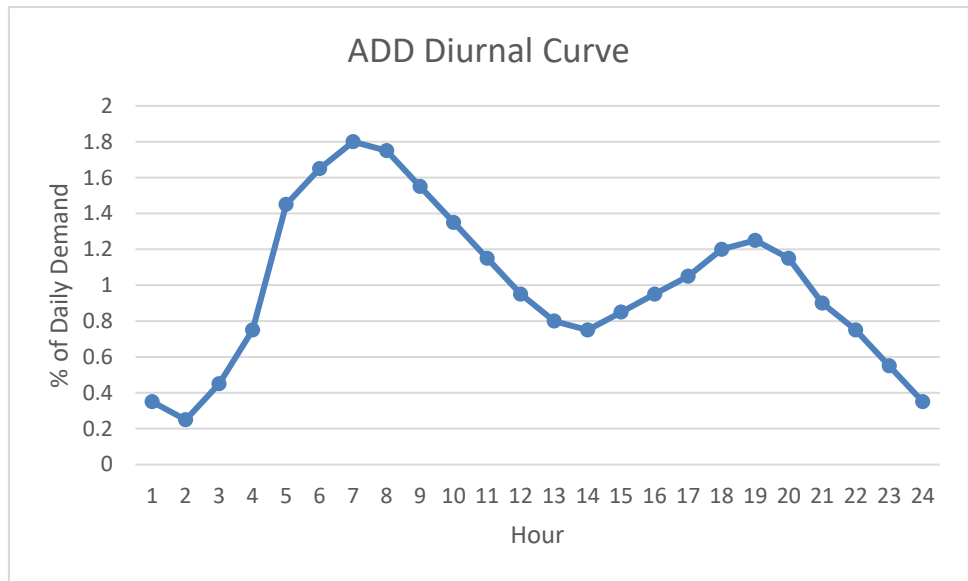
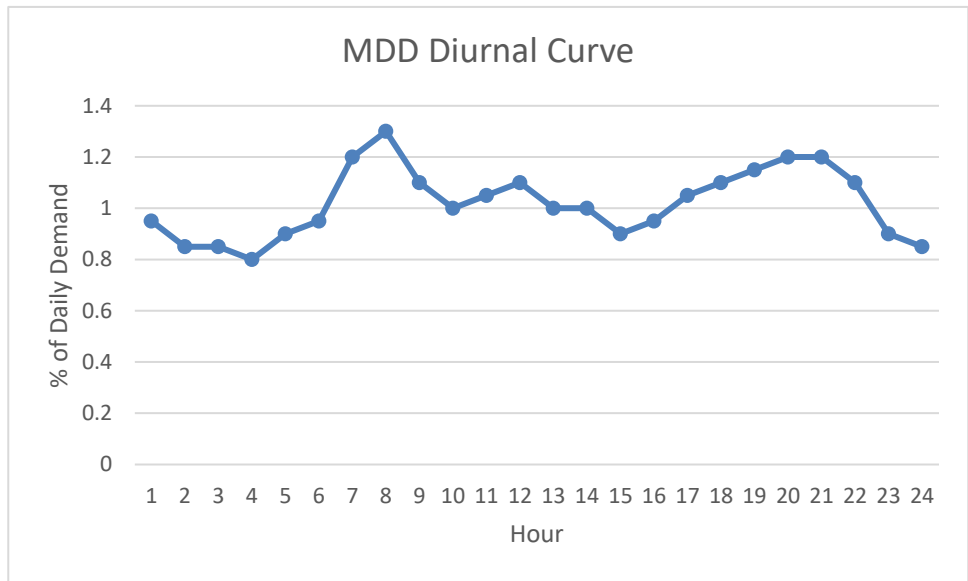

Figure 2 – MDD Diurnal Curve



2.3 Existing System Available Flow for Fire Protection

Designing a water system to provide adequate fire protection is an important consideration. Adequately sized watermain is an important consideration to supply desired fire flows. Guidelines for determining fire flow requirements are provided by the ISO. ISO is the insurance service organization responsible for evaluating and classifying municipalities for fire insurance rating purposes. Available fire flow for fire protection (fire flow) in this report is defined as the flow capacity at a point in the water distribution system which causes the pressure to fall to 20 psi (residual pressure). A map of the fire flow analysis for the distribution system under a maximum day demand is shown in Figure 8 in Appendix B. Note that the fire flow analysis for the

distribution system was done for junctions (watermain intersections and at dead-ends) instead of hydrants, so the fire protection in some areas may be better than shown as a hydrant may be nearby on a larger sized watermain. In general, low fire flows occur where normal pressures are already low, and in areas with small diameter watermains, or in areas with older watermains. Dead-ends typically have noticeably weaker fire flows than looped watermain as well.

To determine if the water system is deficient in available fire flow, a basis for fire protection must be established. For planning purposes, the minimum fire protection requirement can be based on land use according to Table 4.

Table 4 – Minimum Fire Flows

Land Use	Flow (gpm)
Park	500
Single-Family	1,000
R-1 Low-Density Single Family	1,000
Two-Family	1,000
Multi-Family	1,500
High-Density Multi-Family	1,500
Service Office	1,500
Community Commercial	2,500
General Commercial	2,500
Industrial	3,500
Mixed Use-Neighborhood	2,000
Mixed Use-Community	2,000
Mixed Use-Regional	2,000

In general, the City is well protected with over 98% of the distribution system having fire flows of 1,500 gpm or higher. When comparing available fire flows with the City's existing land use map there are a few areas where the available fire flow may be deficient. Specifically, a small industrial land use area north of Highway 10 and south of the southern dead-end of Jasper Street NW, as well as the dead-end of 142nd Lane NW in the southeastern part of the City.

2.4 Existing System 24-Hour Simulation – Treatment Plant

Similar to the existing system 24-Hour simulation, a 24-hour extended period simulation was run for ADD and MDD demands to model how the existing system performs in terms of pressure, velocity, and tank levels with a treatment plant as the sole source of water. With a single source versus wells spaced throughout town, the worry is that the furthest points from the treatment plant may experience lower pressures due to headloss through the distribution system. An ADD of 1.72 MGD and a MDD of 4.7 MGD were assumed.

Figures 9-10 in Appendix B show the operation of the treatment plant high service pumps and towers for both demand scenarios, and Figures 11-12 in Appendix B show the minimum pressures for both demands scenarios. Pressures across the system were generally consistent throughout the 24-hour simulation for both demand scenarios, and at no point did the pressure drop below 50 psi during both demand scenarios, and at no point did velocities exceed 5 feet per

second. Modeling of both demand scenarios show that the existing system performs very well with a treatment plant as the sole source of water.

2.5 2040 System 24-Hour Simulation

By 2040, Ramsey's estimated average day demand is expected to increase to 3.5 MGD, and the maximum day demand is expected to increase to 10.3 MGD. With this increased demand, it is important to ensure that the distribution system and storage facilities are adequately sized to meet the future demand. The storage capacity of the current water system is 4 MG, which will still meet the Minnesota Department of Health's recommendation of having enough storage to meet or exceed the ADD, so additional storage will not be required through 2040.

Although it is impossible to know where future watermain will be required, future watermain was added and sized according to previous reports, which can be seen in Figures 15-16 in Appendix B. Future demands were allocated based on locations future pipes and future development areas.

Figures 13-14 in Appendix B show the operation of the treatment plant and towers for both demand scenarios, and Figures 15-16 in Appendix B show the minimum pressures for both demands scenarios of the 2040 24-hour simulation. Again, the pressures across the system were generally consistent throughout the 24-hour simulation for both demand scenarios, and at no point did the pressure drop below 50 psi during the ADD scenario. Pressures did drop to as low as 37 psi during the MDD scenario in some areas in the future north development between 173rd Ave NW and 181st Ave NW due to the higher elevations, although this can be alleviated by keeping the towers at a higher level. Velocities were kept below 5 feet per second, although a short segment of 16" pipe on Bunker Lake Blvd NW approached around 5.5 feet per second during the MDD scenario for a short period of time, although this is not a concern.

2.6 Distribution Modeling Conclusions and Recommendations

Modeling of Ramsey's water system shows that it performs well currently and with a treatment plant now and in the future. If the City chooses to build a water treatment plant, raw watermain will be needed to bring the well water to the treatment plant. Currently there is raw watermain for bringing well water to the pumphouses, which can be utilized for the treatment plant, although additional and bigger sized raw watermain will be required. The raw watermain required is shown in Figure 1 in Appendix I and was assumed in the modeling. Of note, the 16" watermain along Bunker Lake Blvd NW should be used as finished watermain and was assumed to be in the modeling.

As the population grows, and thus the water demand, there are a few recommendations for improving the water system to be able to operate efficiently with 2040 demands. First, it is recommended that the 16" watermain along Bunker Lake Blvd NW be tied into the 12" watermain along E Town Center Drive. Modeling did not assume this, although it may be advantageous to do so beyond 2040 if the private well owners in the center of town go on city water. The models did assume that the 16" watermain along Bunker Lake Blvd NW ties into the 8" and 12" watermain along Rhinestone Street NW.

Second, with the proposed treatment plant location being on the west side of town, it may be beneficial depending on future demands to extend the 12" watermain along Armstrong Blvd NW to Bunker Lake Blvd, and to extend the 16" watermain along Bunker Lake Blvd NW to E Town

Center Drive. The extensions of those pipes was assumed in the 2040 modeling analysis and prevented additional pipes in the area from exceeding a velocity of 5 feet per second.

Third, as can be seen in Figure 19 in Appendix B, the water level in Tower 2 approached and stayed at an HGL of 1,033 feet. This was done by utilizing an altitude valve in the model for the tower. Due to Tower 2's close proximity to the treatment plant, there is a risk of the tower to overflow, especially during a MDD scenario, as the treatment plant pumps into the system to fill Tower 1. Because of this, an altitude may have to be installed in the future

3 Drinking Water Quality

The City of Ramsey's water is tested on a regular basis by the City and by Minnesota Department of Health (MDH). The following sections discuss Primary and Secondary test results for the City's wells and distribution system.

3.1 Primary Drinking Water Standards

Primary Standards are legally enforceable standards that public water suppliers are required to meet. Primary standards protect public health by regulating the levels of certain contaminants in public water supplies. The United States Environmental Protection Agency (US EPA) establishes maximum contaminant levels (MCLs) for primary standard constituents. Regulated constituents include microorganisms, disinfectants, disinfection byproducts, inorganic chemicals, organic chemicals and radionuclides. A few primary contaminants have been detected in Ramsey's water as shown on Table 5; however, the contaminants detected well below their respective MCLs.

Table 5 – Water Quality - Primary Drinking Water Standards

Contaminant	Highest Average or Highest Single Test Result	Range of Detected Test Results	MCL	90% of Results Were Less Than	EPA Action Level
Lead	-	-	-	1.9 ppb	90% of homes less than 15 ppb
Copper	-	-	-	0.82 ppm	90% of homes less than 1.3 ppm
Barium	0.11 ppm	-	2 ppm	-	-
Arsenic	1.49 ppb	-	10.4 ppb	-	-
2,4-D	0.03 ppb	-	70 ppb	-	-
Combined Radium	2.2 pCi/l	-	5.4 pCi/l	-	-
Total Trihalomethanes (TTHMs)	2.1 ppb	1.70 – 2.10 ppb	80 ppb	-	-
Total Chlorine	1.14 ppm	0.77 – 1.64 ppm	4.0 ppm	-	-
Fluoride	0.81 ppm	0.59 – 1.00 ppm	4.0 ppm	-	-

Notes: Data from Ramsey’s Consumer Confidence Report

3.2 Manganese

According to the Minnesota Department of Health (MDH), too much manganese in drinking water can have negative health effects for babies under one year old. At high concentrations, manganese can also have negative health effects for children and adults. To protect bottle-fed infants, MDH recommends manganese levels of less than 0.100 mg/L. To protect children and adults, a manganese level of less than 0.300 mg/L is recommended. To ensure that all residents are protected, MDH has established a Health Based Value (HBV) for Manganese of 0.100 mg/L.

Manganese also has a secondary standard of 0.05 mg/L where levels above can cause color, staining, and taste issues.

Recently, manganese was included as a contaminant to be monitored under the Fourth Unregulated Contaminant Monitoring Rule (UCMR4), which is discussed in later in this chapter. The City of Ramsey conducted UCMR4 sampling in 2019 which included sampling for manganese. As shown in Table 6, Wells No. 1, 3, 4, and 8 tested above the MDH HBV. Due to the high levels of manganese, MDH has recommended to the City that they develop short-, mid-, and long-term plans to address the high levels. In response to the high levels, the City began using wells with the lowest levels of manganese, and when required to use more wells during higher demand times, the City developed a plan to mix the water from the low level wells with the

high-level wells. As a long-term plan, the City is in the process of determining the best option, but are considering:

- Mixing water from different wells to lower manganese wells;
- Drilling new drinking water wells;
- Installing City filtration systems;
- Constructing a water treatment plant; and
- Using water from neighboring municipal water systems.

Table 6 – Manganese in Ramsey Wells

Well	Manganese (mg/L)	MDH HBV (mg/L)
Well 1	0.320	0.100
Well 3	0.229	0.100
Well 4	0.371	0.100
Well 5	0.022	0.100
Well 6	0.023	0.100
Well 7	0.052	0.100
Well 8	0.223	0.100

Note: Well 2 used exclusively for irrigation

3.3 Secondary Drinking Water Standards

Secondary Standards are non-enforceable guidelines for contaminants that cause aesthetic or cosmetic effects, such as taste, odor and color, and can cause problems with piping. The Secondary Standard for manganese is discussed in Section 3.2. Table 7 presents the iron and hardness data for Ramsey’s wells.

Table 7 – Iron and Hardness in Ramsey Wells

Well	Iron (mg/L)	Hardness (mg/L CaCO ₃)
Well 1	0.551	256
Well 3	0.529	280
Well 4	0.240	-
Well 5	0.801	-
Well 6	0.787	211
Well 7	0.818	225
Well 8	0.704	-

3.3.1 Iron

The secondary standard for iron is 0.3 mg/L where iron concentrations above the secondary standard can cause a rusty color to the water, sediment build-up, a metallic taste, and reddish or orange staining. As shown on Table 2, the drinking water from the Ramsey wells consistently

exceeds the Secondary Standard for iron with concentrations ranging from 0.240 mg/L to 0.818 mg/L.

3.3.2 Hardness

Hardness, which is a measurement of multivalent cations, such as calcium and magnesium, is an aesthetic issue due to its ability to cause scaling and build-up on fixtures, as well as its reaction with soaps producing a sticky and gummy deposit. Although not included as a secondary standard, water with a hardness above 120 mg/L as CaCO₃ is considered hard water.

As shown on Table 2, the drinking water from Ramsey's wells is considered hard with a hardness ranging from 211 mg/L to 280 mg/L.

3.4 Emerging Contaminants

The US EPA uses the Contaminant Candidate List (CCL) and the Unregulated Contaminant Monitoring Rule (UCMR) to screen potential contaminants for further regulation. The CCL and UCMR are discussed in the following sections.

3.4.1 Contaminant Candidate List

The US EPA maintains a Contaminant Candidate List (CCL) for contaminants that may need to be regulated, which is published every five years. The current CCL includes 97 chemicals or chemical groups and 12 microbiological contaminants and can be seen in Appendix C along with the other published CCLs. The list includes chemicals used in commerce, pesticides, biological toxins, disinfection byproducts, and waterborne pathogens. The contaminants on the list are not currently regulated by existing Primary drinking water standards. It should also be noted that the US EPA reviews existing regulated contaminants. If existing standards are modified, they are typically lowered (i.e. arsenic) and not raised.

3.4.2 Unregulated Contaminant Monitoring Rule

Along with the CCL, UCMR is used by the EPA to collect data for contaminants that are suspected to be present in drinking water, but do not have health-based standards set under SDWA. Occurrence data are then used to determine whether particular contaminants should be regulated in the interest of protecting public health. Monitoring under UCMR is conducted every five years for no more than 30 contaminants and is required for all community water systems over 10,000 people, and for a representative sample of systems with populations less than or equal to 10,000 people. Selection of contaminants to be monitored is determined through existing prioritization processes, including contaminants previously monitored under UCMR, and the CCL. Other contaminants of interest may also be chosen. Since the promulgation of UCMR, there have been four rounds of sampling with the fourth round (UCMR4) currently underway. Among the four rounds of UCMR sampling, some of the contaminants include:

- Pesticides
- Volatile Organic Compounds (VOCs)
- Synthetic Organic Compounds (SOCs)
- Metals
- Hormones
- Flame Retardants

- Perfluorinated Compounds (PFAS)
- Disinfection Byproducts
- Cyanotoxin Chemicals
- Other chemicals used in industrial and manufacturing practices

The majority of these contaminants are from anthropogenic, or human activity, sources, and thus necessitates the need to be vigilant in protecting City wells from pollution. As discussed further in Chapter 5, the City’s wells are well protected from anthropogenic pollution, but continued safeguarding of the wells will be crucial in preventing a new contaminant in the City’s drinking water supply that requires treatment.

Although it isn’t possible to predict what contaminants will be regulated in the future, having flexibility in a treatment system is important to provide treatment options for possible future contaminations, new regulations for contaminants, and as testing abilities continue to improve.

4 Water Demand

Ramsey’s average daily water demand from 2009 to 2019 ranged from 1.6 to 1.9 million gallons (MGD). The maximum daily demand, usually occurring during summer months due to lawn watering and other non-consumptive use, ranged from 4.1 to 5.5 MGD.

The projected annual average water demand for the City is expected to increase to 3.5 MGD and up to a projected daily maximum of 10.3 MGD in the year 2040. A list of future water projections from the City’s Water Supply Plan is included below.

Table 8 – Projected Water Demands

Year	Projected Total Population	Projected Population Served	Projected Average Daily Demand (MGD)	Projected Maximum Daily Demand (MGD)
2020	27,550	13,921	1.8	5.3
2025	30,450	18,547	2.4	7.0
2030	33,350	22,987	3.0	8.7
2040	39,150	26,988	3.5	10.3

4.1 Adequacy of Existing Water Supply

As discussed in Section 1.2, if a centralized water treatment plant is constructed, Wells No. 1 and 2 would not initially be connected to the water treatment plant due to the significant expense required to extend trunk watermain to the water treatment plant. The existing firm capacity without considering Wells No. 1 and 2 is 4,850 gpm or 7.0 MGD. Table 8 predicts that Ramsey has sufficient firm capacity without Wells No. 1 and 2 through the year 2025. When maximum day demands reach 7.0 MGD, Ramsey should consider drilling another well.

By the year 2040, Ramsey will need 10.3 MGD in firm capacity. To provide this capacity without using Wells 1 and 2, an additional 3 wells will be needed by 2040 (assuming 850 gpm per well).

5 Groundwater Availability

The City of Ramsey currently utilizes groundwater as its exclusive source of drinking water. For planning purposes, the City needs to understand whether groundwater can continue to provide existing and future water demands.

5.1 Description of the Hydrogeological Setting

The following sections describe the hydrogeology (groundwater) in Ramsey.

5.1.1 Surficial Hydrogeological Setting

The surficial geology in the region is primarily associated with erosional and depositional glacial events during the Quaternary Period. Surficial aquifers throughout this region have highly variable aquifer properties. The Metropolitan Council classifies these as having a moderate to high water yield for potable use; however, it is often challenging to identify the locations for the most productive units with some areas providing little or no yield for water supply. Depending on the location, the presence of finer grained units that can act as confining layer will affect water recharge rates to these aquifers and limit the quantity of water these aquifers can supply. Surficial aquifers are often the first aquifer to be recharged and thus can be more vulnerable to contamination. Therefore, the overall water quantity and quality is described by the Metropolitan Council as variable.

5.1.2 Bedrock Hydrogeologic Setting

The bedrock underlying the City of Ramsey and surrounding areas consists of Precambrian to Ordovician age Paleozoic sedimentary strata overlying Precambrian age basement rock. While variation and extent of bedrock aquifers occur, in general five regional aquifers are described and support much of the potable water for the Twin Cities region, from oldest to youngest: (1) Mt Simon-Hinckley (2) Tunnel City-Wonewoc (3) Prairie du Chien-Jordan (4) St. Peter, and (5) Quaternary aquifers. These aquifers are hydrologically disconnected by a variety of interbedded confining layers. Regional aquifers can also be subdivided further; for example, the Tunnel City-Wonewoc Aquifer maybe be hydraulically disconnected if the Lone Rock Formation (of the Tunnel City Group) acts as a confining unit. Primary lithology, and hydrogeologic designations are summarized in the table below, from oldest to youngest, for the area.

Table 9 – Bedrock Aquifers

Geologic Formation	Age	Primary Hydrogeologic Designation	Approximate Thickness	Primary Regional Lithology
Hinckley Sandstone	Pre-Cambrian	Aquifer	Not Available	Quartzose sandstone overlying the Precambrian bedrock
Mt Simon Sandstone	Middle Cambrian	Aquifer	~200 to 336 ft	Quartz sandstone that contains interbedded siltstone and very fine sand.
Eau Claire Formation	Middle to Upper Cambrian	Confining	~60 to 90 ft	Fine grained sandstone, siltstone and shale.
Wonewoc Sandstone	Upper Cambrian	Aquifer	~ 50 to 60 ft	Very fine to very coarse grained Sandstone.
Tunnel City Group	Upper Cambrian	Aquifer / Confining	~ 150 to 180 ft	Lower is massively bedded very fine to fine-grained sandstone; upper is coarse grained sandstone.
St Lawrence Formation	Upper Cambrian	Confining	~ 38 to 59 ft	Dolomitic siltstone with interbedded very fine-grained sandstone and shale.
Jordan Sandstone	Upper Cambrian	Aquifer	~ 85 to 100 ft	Upward sequence of fine to coarser grained sandstone.

Regionally other bedrock aquifers exist that are not listed above, the following are aquifers present within the City of Ramsey area. These aquifers are discussed in detail in the following sections. Throughout the City of Ramsey, The Tunnel City group is the uppermost Bedrock unit meaning the St Lawrence and Jordan Sandstone is only sparsely present. Above these Bedrock units are unconsolidated sediment discussed in sections above.

5.1.2.1 Jordan Aquifer

The Jordan Aquifer is generally considered to be hydrologically connected to the Prairie Du Chien Unit. However, as evident from the geologic bedrock map (Figure 2 in Appendix D) the Prairie Du Chien Unit was either not deposited or has been entirely eroded through much of this area. The thickness and presence of this aquifer through this area is scarce and laterally disconnected. Where present, Within the City of Ramsey, the Jordan Sandstone thickness is minimal at around 20-30 feet and appears heavily eroded. Quaternary deposits directly overlay this unit and the Jordan Sandstone is likely recharged by these deposits.

5.1.2.2 Wonewoc / Tunnel City Group

The Tunnel City Group and the underlying Wonewoc Sandstone (formerly known as the Franconia-Ironton-Galesville Aquifer) supply water for much of the Northwest Metro region. Presence and thickness of the Tunnel City is depicted on Figure 6 in Appendix D, and for the Wonewoc on Figure 8 in Appendix D. Areas where the Aquifer is not present primarily occur within bedrock valleys where previous streams and surface water features carved away the bedrock unit. A large unconformity of the Wonewoc Sandstone is depicted within Anoka County where heavy erosion of this unit appears to have taken place prior to the deposition of the Tunnel City Aquifer. This area is depicted where the Wonewoc aquifer thickness thins or is not present

(Figure 8 in Appendix D). Potentiometric surfaces of this units are depicted on Figures 7 in Appendix D for the Tunnel City and Figure 9 in Appendix D for the Wonewoc Sandstone. Potentiometric surfaces were created by the Minnesota Geologic Survey and provide a rough estimate for water elevations for a proposed well within these units and their groundwater flow direction.

The Metropolitan Council generally describes the productivity of the Tunnel City – Wonewoc Aquifer as variable. Yields tend to be moderate to low with some of the highest yields reported where bedrock units are highly fractured.

5.1.2.3 Mt. Simon-Hinckley Aquifer

The Mount Simon-Hinckley Aquifer is generally described by the Metropolitan Council as a high to moderate yield aquifer. New high-capacity wells are generally not permitted by the Minnesota Department of Natural Resources as use has been restricted by Minnesota Law, therefore it is not discussed in this report in greater detail.

5.1.3 Ramsey Municipal Wells

The City of Ramsey wellfields are comprised of 8 wells. Wells 1 and 2 are located in the southeastern portion of city limits, while Wells 3 through 8 are located in the south-central portion of the City. The City of Ramsey currently receives all of its potable water from the Tunnel City-Wonewoc aquifer. The well locations are depicted on Figure 1 in Appendix D. These wells are detailed in the table below.

Table 10 – Ramsey Well Data

Well No.	Unique Well No.	Date Constructed	Aquifer	Total Depth (ft)	Casing Depth (ft)	Casing Diameter (in)
1	161441	1984	Tunnel City Group	323	243	14
2	416183	1987	Tunnel City Group	320	240	14
3	580306	1997	Tunnel City-Wonewoc	345	222	30 x 24
4	580313	1998	Tunnel City-Wonewoc	321	191	30 x 24
5	593672	2000	Tunnel City-Wonewoc	316	215	30 x 24
6	706840	2005	Tunnel City-Wonewoc	390	282	30 x 24
7	743832	2007	Tunnel City-Wonewoc	332	216	30 x 24
8	743833	2007	Tunnel City-Wonewoc	354	245	30 x 24

5.1.4 Daily Volume of Water Pumped

The Minnesota Department of Natural Resources (MnDNR) permits high-capacity wells and records total water use within wells deemed to be high capacity. All of the City of Ramsey wells are considered high-capacity wells with an approved MnDNR appropriation permit. All yearly water use is recorded within MnDNR's Water Permitting and reporting system (MPARS). Additionally, The City of Ramsey has an approved Water Supply Plan (Third Generation for 2018-2028).

The City of Ramsey currently preferentially utilizes wells from their south-central well field that includes wells 3 through 8. City Wells 1 and 2 are to the southeast of the primary well field and has a decreasing utilization rate. Well locations are depicted on Figure 1 in Appendix D.

As discussed in Section 4, the average daily water demand from 2007 to 2017 ranged from 1.62 to 1.92 million gallons (MGD). The maximum daily demand ranged from 4.1 to 5.5 MGD. The projected annual average water demand for the City is expected to increase to 3.5 MGD and up to a projected daily maximum of 10.2 MGD in the year 2040.

5.1.5 Aquifer Response to Well Pumping

Aquifer response to well pumping can be measured in many ways. The most common and observable measurement within a well is through measurement of the drawdown, or change in static water levels, and also through calculating the well specific capacity. These measurements help to quantify water use within a well. As a well continues to pump it creates a radius of influence where nearby water is drawn down into what is called a cone of depression. This correlates to well interference and can have a combining effect when multiple high capacity wells are pumping. These terms are discussed in the Minnesota Department of Health publication, "A Guide to the Rules Relating to Wells and Borings" (Minnesota Rules, Chapter 4725). The adjacent image from the handbook describes this terminology. The following sections will discuss these terms in detail.

5.1.5.1 Well Drawdown

Well drawdown is the decrease of water from the baseline static water level. It can also be described as a decrease in water elevation, potentiometric surface, or water head. As a well is pumped, drawdown is induced by the removal of a volume of water from the aquifer. As the well continues to operate it can also create an area around the well where water is drawdown. This area of drawdown is known as a cone of depression or the area of Influence from a pumping well.

When a well discontinues pumping, water from surrounding aquifers will flow into the area and bring water levels back to static levels. Pumping temporarily creates an area of low potentiometric water pressure, and when the well is shut off water will flow into the area to balance out that change in potentiometric surface. This is known as recharge, or recovery. The recovery period like the drawdown is determined by the hydrogeological properties of the aquifer. Drawdown observed in the City of Ramsey wells are typical for Twin Cities bedrock aquifers. The following chart depicts a drawdown and recover of Well 5 during a 2-day period starting May 3rd to May 5th in 2019.

Figure 3 – Terms Relating to Well Performance

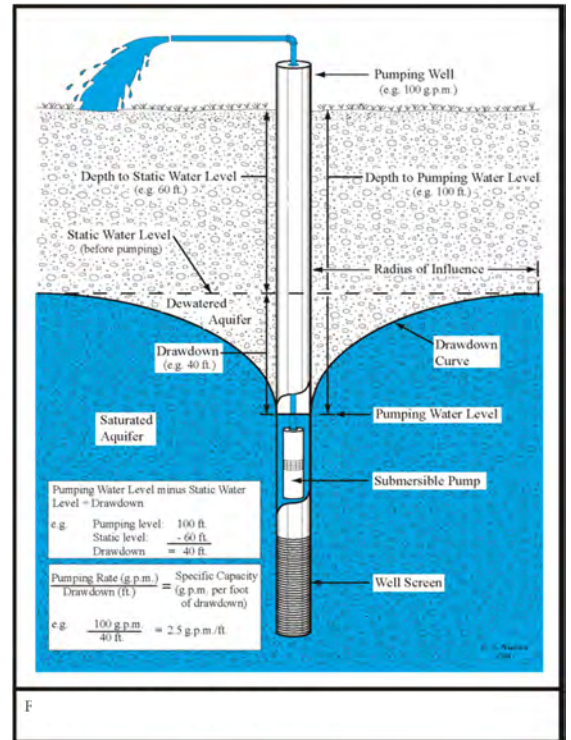
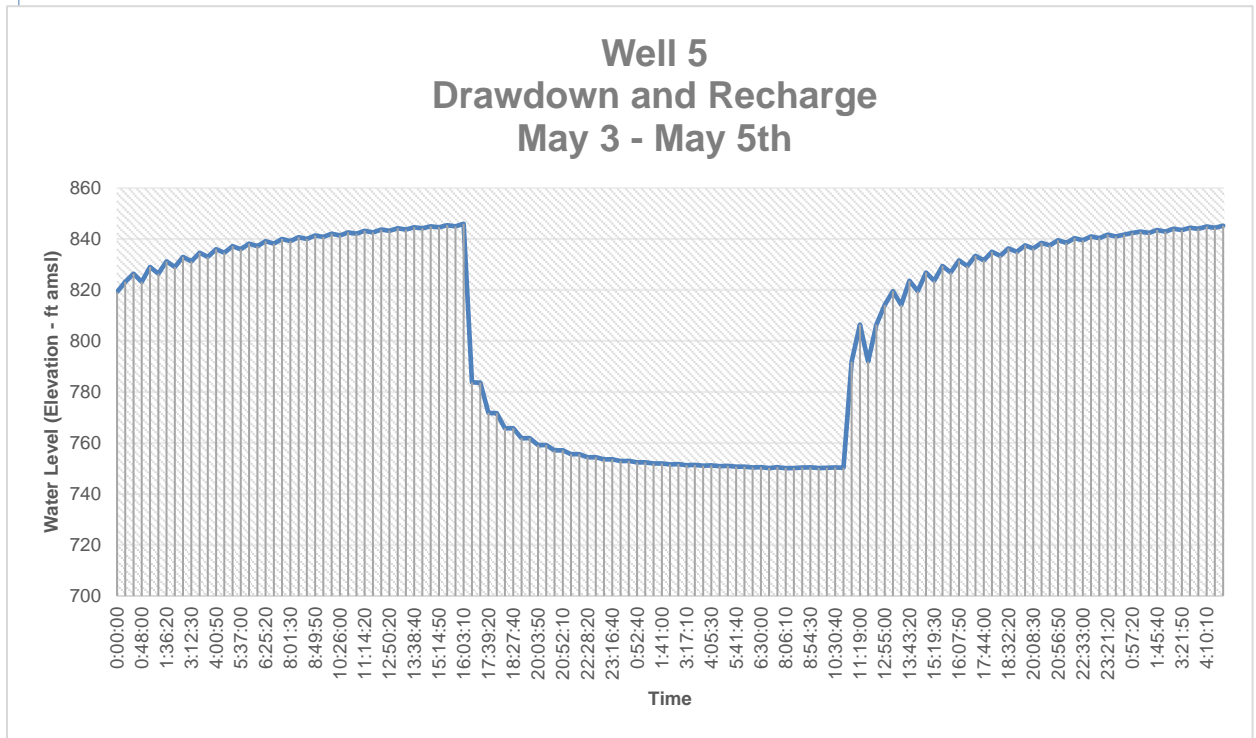

Figure 4 – Well 5 Drawdown and Recharge



At the start of this period, Well 5 water levels were recovering to static at approximately 23 feet below ground surface. Pumping commenced at 15:15 on May 3rd and continued for the next 18 hours. Initial drawdown or instantaneous drawdown is depicted by the step increase in drawdown from 16:51 to 18:27. Water levels over this period fell 80 feet. Water levels over the following 18 hours decreased another 40 feet. The well ceased pumping at 10:30 on May 3rd and recharge to the aquifer took 17 hours to return to static water levels.

Current well pumping and rates of recharge appear good with the aquifer being able to recharge water to static in a relatively low period of time.

5.1.5.2 Well Drawdown and Available Head

Water levels from the source water aquifer, the Tunnel City-Wonewoc Aquifer, are much higher than the topographic elevation of the top of bedrock. This scenario is known as a confined aquifer, where the potentiometric surface, or water head, is higher than the topographic location of the aquifer.

Presently, water quantity throughout the region is good and there are no regulations actively being enforced on pumping levels within a well. Well interference and long-term groundwater trends through pumping/drawdown is conducted on a case by case basis by the Minnesota DNR if a problem arises.

Typically, it is not a good idea to drawdown water levels in a confined aquifer below the top of bedrock as it can introduce oxygen into the formation. Additionally, water levels should stay sufficiently above the specifications of the water pump design.

For confined aquifers, the Minnesota DNR has established a two-tiered aquifer protection threshold system to ensure the long-term viability of the pumped aquifer and to prevent exceedance of the aquifer safe yield as defined by MN Rule 6115.0630 Definitions Subps.15 and 16. These thresholds allow for appropriation from the aquifer but establishes minimum water level elevations to be maintained as a safeguard to protect the structural integrity of the aquifer itself. Threshold elevations are set in observation wells completed in the source aquifer and not pumped wells.

- The first threshold is set at an elevation that is 50% of the pre-pumping available head above the top of the aquifer. If water levels drop to the 50% threshold, pumping will need to be evaluated and a possible reduction in rate and volume may be required.
- The second is a water level elevation associated with 25% of the pre-pumping available head above the aquifer. At the 25% threshold, pumping would need to cease to prevent exceeding the safe yield for the artesian aquifer.
- If more than one aquifer is impacted by pumping, then thresholds are set similarly in the other aquifers.

The table below depicts the static water level and the approximate available head above top of aquifer in the City of Ramsey’s current municipal wells taking account the Minnesota DNR 50% and 25% thresholds.

Table 11 – Drawdown in Ramsey Wells

Well No.	Unique Well No.	Total Depth (ft)	Casing Depth (ft)	Static Water Level Depth (ft)	Approximate Drawdown to Top of Aquifer (ft)	Approximate Drawdown to 50% threshold (ft)	Approximate Drawdown to 25% threshold (ft)
1	161441	323	243	9.5	233.5	116.75	175.1
2	416183	320	240	9.5	230.5	115.25	172.8
3	580306	345	222	26	196	98	147
4	580313	321	191	18	173	86.5	129.7
5	593672	316	215	25	190	95	142.5
6	706840	390	282	37	245	122.5	183.7
7	743832	332	216	25	191	95.5	143.2
8	743833	354	245	15	230	115	172.5

These MnDNR threshold values are approximate as an observation well has to be established by the MnDNR for baseline water elevations; however, the table above provides an estimate for which the city should manage water levels.

5.1.5.3 Well Specific Capacity

Well specific capacity is the rate of pumping per unit of drawdown expected. This is generally expressed as gallons per minute (GPM) per foot of drawdown. All of the City of Ramsey wells experience a sharp initial displacement of water as the wells are turned on (as seen in Well 5 drawdown examples above). For the purpose of this report, this initial displacement was not considered in the calculations for Well Specific Capacity in order to give a more accurate depiction of how the aquifer will respond once stabilized to various pumping rates.

Well Specific Capacity for the City of Ramsey was determined to be approximately 30 to 40 GPM / ft after initial displacement. This indicates a 30 to 40 GPM increase in pumping rate will increase total drawdown by 1 foot. The Specific Capacity was established analyzing the following recent results from pumping.

5.1.6 Bedrock Hydrogeologic Sensitivity to Pollution

Water quality for bedrock aquifers are generally a function of recharge rates for water originating from surficial waters, or percolation from direct precipitation, that may carry contaminants. Aquifers generally flow from areas of high potentiometric conditions to areas of low potentiometric conditions which can be influenced by surface topography, bedrock topography, Well Influence, and the hydraulic properties of the geologic units.

The areas of higher potentiometric conditions often correspond to recharge areas or where water enters the aquifer and, as a result, are the most susceptible to distributing such contamination to the bedrock aquifer. Recharge areas may have variable recharge rates and may even decrease because of the properties of the material in which it flows. Confining units, formations primarily made up of fine-grained material, reduce groundwater flow rates and provide more geologic protection. Geologic protection can be described in categories as to how quickly water can percolate from the surface to the bedrock from 'Low' to 'High'.

Figure 4 in Appendix D depict bedrock protection 'Geologic Sensitivity' for Anoka County. While the majority of the bedrock aquifers exhibit a low geologic sensitivity, some areas are depicted with a high sensitivity. The areas of high sensitivity do not appear to correspond to specific bedrock geologic conditions. Instead, high sensitivity is more likely related to where confining units have been removed and where coarse-grained Quaternary sediment overlies the bedrock surface.

Figure 5 in Appendix D depicts tritium samples taken within the City of Ramsey. Tritium is a radioactive isotope of hydrogen that can be used to indicate water age. MDH classifies young (post-1953) water, as indicated by the presence of 1 TU or greater in the well water. Tritium results for these samples depict a mixed result. This mixed result reflects uncertainty about the pathway for young water (containing tritium) to reach the deeper bedrock aquifers. Although the presence of tritium may be the result of a compromised well casing allowing surface water seepage, conservatively, it is assumed that some pathways may exist.

5.1.7 Well Spacing

Determining the proper spacing of wells in Artesian Aquifers is a balance of well drawdown, the ability of the surrounding formation to recharge, and further economic considerations (USGS 1961). In general, the farther apart high-capacity wells are from one another, the less mutual interference will occur on the wells. Additionally, the economics of well spacing needs to be weighed against the potential drawdown of the wells.

The USGS in 1961 developed a method utilizing the Theis equation for hydraulics to determine expected well drawdown and the surrounding cone of depression. Calculations using this equation were completed to understand the hydrogeology of this aquifer system.

The following example depicts drawdown in well 8 over the course of 12-hour period while well 7 was pumping at an Average of 800 GPM.

Figure 5 – Drawdown in Observation Well 8

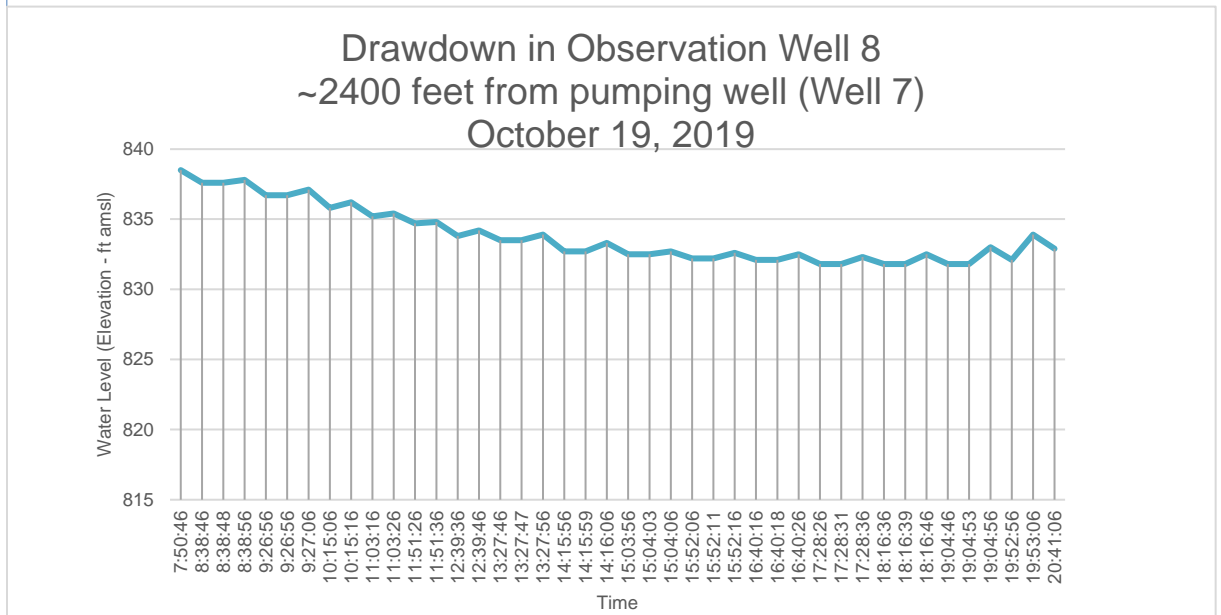

During the course of Well 7 pumping, Well 8 at a distance of 2,400 feet observed approximately 6 to 9 feet of drawdown.

The Theis equation predicts a cone of depression approximately 2,448 feet from pumping well 7.

Theis Equation for the City of Ramsey		
Time =	0.5	days
Theis W(u) Function	0.752	unitless
Drawdown =	6	ft
Transmissivity =	11493	gpd/ft
Pumping Rate =	800	gpm
Theis u variable =	0.390	unitless
$r^2 = 4Ttu / 4S$		
Storativity =	0.0002	unitless
Radius rounded for map	2400	ft

These results indicate that a single well pumping at current well field spacing does not induce mutual well interference. This 6-foot cone of depression is depicted on Figure 11.

However, complexities arise as present-day conditions see the use of 3 to 5 concurrent wells, and a 2040 demand increasing up to a projected 500% daily maximum demand. In order to model these scenarios and their resulting cone of depressions a groundwater model was developed.

5.1.8 Model

The groundwater flow and cone of depression calculation for the City of Ramsey were determined using an existing regional MODFLOW model that was developed by Barr Engineering Company for the Metropolitan Council (Metro Council, 2014). MODFLOW is a 3D, cell-centered, finite difference, saturated flow model developed by the U.S. Geological Survey (McDonald and Harbaugh, 1988; Harbaugh et al., 2000).

MODFLOW was developed by the United States Geological Survey and is publicly available. The specific software code used for this delineation was MODFLOW-2005 (Harbaugh, 2005). The program has been thoroughly documented, is widely used by consultants, government agencies, and researchers and consistently accepted in regulatory proceedings. MODFLOW is also an extremely versatile program capable of simulating groundwater flow in up to three dimensions while offering a variety of boundary condition options, confined or unconfined aquifer conditions and allowing for vertical discretization through the use of layering.

The Metro Model consists of nine layers that represent the major aquifers and aquitards within the seven-county metropolitan area. These layers represent, from top to bottom (youngest to oldest), the following units: (1) surficial aquifer of glacial deposits; (2) St. Peter Sandstone or Quaternary Buried Artesian Aquifer; (3) Prairie du Chien Group; (4) Jordan Sandstone; (5) St. Lawrence Formation (aquitard); (6) Tunnel City Group; (7) Wonewoc Aquifer, (8) Eau Claire Formation (aquitard); and (9) Mt. Simon Sandstone. The regional groundwater model was calibrated to steady-state water levels and river base flows. Model parameter development and error is discussed in the Metro Model report.

A local model limited to an approximate radius around the city limits was extracted from the regional seven-county model using telescopic mesh refinement with the Groundwater Vistas software. Constant and general head boundaries around the limits of the model along with wells, rivers and lakes, and infiltration, provided the model boundary conditions.

The model grid was refined around the City of Ramsey wells. Variable grid spacing was used, ranging from approximately 2 meters near the City of Ramsey wells to approximately 500 meters at the edge of the grid.

Prior to their use in the delineations, the following modifications were incorporated in the refined models:

- Local areas of modified horizontal conductivity were included in the model.
- The pumping rates for baseline (no pumping), maximum present-day use, and projected 2040 demand were inputted into scenarios of the model.

To determine the water contours of the aquifer and the resulting cone of depressions multiple model runs using multiple flow rates were inputted into the city wells. Baseline conditions were established creating a model that input no pumping from the City wells. This represents static aquifer water levels without influence of the City wells. Water elevations from this baseline condition is depicted on Figure 12 in Appendix D. The results from this model run are verified and match MnDNR hydrogeologic atlas potentiometric surface predictions depicted in Figure 7 and Figure 9 in Appendix D.

The second model run input pumping values from June 12, 2019 to predict the cone of depression caused from 8 hours of pumping 4 wells. The resulting head values from this model

were subtracted from the baseline model. Results from this calculation are shown in Figure 13 in Appendix D. This Figure depicts the cone of depression created on June 12, 2019. To check accuracy of the model results Well 3 a non-pumping observation well saw water levels drop approximate 12-15 feet from baseline conditions, essentially matching modeled results.

The third model run adjusted June 12, 2019 pumping wells to be increased to projected 2040 demand. The resulting cone of depression is depicted on Figure 14 in Appendix D. Results indicated almost double the drawdown depicted from the second model run. Well 3 was again input as a non-pumping observation well and would observe 40 feet of drawdown under these conditions.

5.1.8.1 Model Calibration

A qualitative evaluation of the calibration can be made by comparing the simulated potentiometric surface (Figure 12 in Appendix D) with observed water level targets obtained from the MWI database and Minnesota Department of Natural Resources Potentiometric Surfaces (Figure 7 and Figure 9 in Appendix D). Upon review, the calibrated flow model generally captures the major features of the groundwater flow system along with the elevation, shape, magnitude, and gradient of the MWI database observed flow field.

A quantitative measure by which to evaluate the success obtained during calibration is to compare the root mean square of the residuals (RMS) and the maximum observed head difference of the calibration dataset. The calibration dataset included water level information from wells in an approximate 16-mile radius of the city's wells. The root mean square residual of the calibration for layers 6 and 7 for the model was approximately 5.15 meters with a Normalized Root Mean Squared of 5.0 percent. It is noted that this error is less than the calibration target of 15 percent (Anderson et al., 2015).

5.2 Groundwater Modeling Conclusions

The Source water aquifer that the City of Ramsey currently utilizes is a deep-confined aquifer comprised of two geologic units, the Tunnel City and Wonewoc Aquifers. Throughout the region, numerous other unconsolidated and bedrock aquifers exist along with substantial surface water bodies such as the Mississippi River. Overall, the area surrounding the Twin Cities has substantial surface and groundwater resources to support present and long term portable water.

At present, there is no reason to assume that the current source water aquifer for the City of Ramsey will not be able to supply potable water for the foreseeable future. The City of Ramsey's source water aquifer and wells are able to meet present day demand and appear to have a noticeable but temporary radius of influence on the surrounding aquifer. The wells are able to support high pumping rates with specific capacity showing acceptable drawdown alongside the aquifer's ability to recharge to static levels within a day of pumping.

The City of Ramsey will need to balance water demand with drawdown to meet Minnesota Department of Natural Resources drawdown thresholds described in MN Rule 6115.0630 Definitions Subps.15 and 16. Two thresholds are in place and regulate that wells must not drawdown MnDNR assigned static water levels to within 50-percent and 25-percent to the top of aquifer. These threshold values are set by a MnDNR observation well and would typically be enforced if long term issues are observed. Thresholds for the City of Ramsey could become a concern if there is extended pumping within a single well or pumping by multiple wells in close proximity.

In summary, it is SEH's opinion that there is a 95% to 99% certainty that the source water aquifer for the City of Ramsey will continue to produce potable water to meet present and foreseeable future demands; however, the City of Ramsey should plan additional well sites to ensure static water levels remain sufficiently above top of aquifers to meet MnDNR thresholds.

Single well pumping for the City of Ramsey, as depicted by Well 5 in May, 2019 saw approximately 90 to 100 feet of temporary drawdown. This observed drawdown nears the MnDNR 50-percent threshold; however, the pumping extended multiple days and recharged within the same time period back to static levels. This supports the ability of the wells to supply continued water and ability to stay within prescribed State Statute.

A single well also creates a radius of influence drawing down adjacent water levels. The zone of influence for a single well was observed and modeled to be approximately two to three thousand feet, meaning that a single well pumping at approximately 800 feet will not cause a significant drawdown in another well. When multiple wells are being utilized such as under heavy day demand or under 2040 conditions the modeled and observed drawdown in nearby wells sees a substantial drop in static water levels from that of a single well pumping. Modeled drawdown during present heavy day conditions depict 30-40 feet of drawdown approximately 1,500 feet around the wellfield. After pumping stops, the aquifer will recharge to static levels within one or two days. In general, it appears new well sites should be spaced at least 1,500 to 2,000 feet away from existing wells to ensure a pumping scheme that gives the aquifer sufficient time to recharge.

Future well sites should attempt to balance the City's current economics, well spacing, and take into account the underlying geology. The City of Ramsey should continue to utilize the current source water aquifer for both a water quantity and a water quality standpoint. The source water aquifer is underneath protective "confining" units that appear to inhibit the influence of new water from brining contaminants to the City's wells and will likely produce consistent water quality unlikely unconfined sources such as surface water that may have a highly variable water quality.

Additional considerations for well Sites should take into account the thickness of the two hydrogeologic units that make up the source water aquifer. The Tunnel City aquifer is not as prolific an aquifer as the Wonewoc aquifer, meaning that the Wonewoc aquifer is a more economical source of water. Figure 15 in Appendix D depicts three potential well sites taking into account these issues. Well Site Area A has Tunnel City aquifer thickness ranging from 100 to 150 feet and Wonewoc thickness ranging from 45 to 60 feet. Well Site Area B has Tunnel City aquifer thickness ranging from 0 to 80 feet and Wonewoc thickness ranging from 35 to 100 feet. Well Site Area C has Tunnel City aquifer thickness ranging from 90 to 100 feet and Wonewoc thickness ranging from 15 to 35 feet. All of these sites have potential for potable water sources, but a test well will need to be installed to confirm their viability. As opportunities to investigate these well sites present themselves the City should consider these as potential well sites.

6 Regional Water Supply Study

Metropolitan Council Environmental Services in conjunction with the Cities of Ramsey, Dayton, Rogers, and Corcoran prepared a study in 2020 that looked at various options for a regional water system. SEH was the consulting engineer on the project. The *Northwest Metro Area Regional Water Supply System Study* (Study) evaluated four approaches to water supply:

- Approach 1: Regional Surface Water Treatment Plant
- Approach 2: Regional Lime Softening Groundwater Treatment Plant
- Approach 3: Regional Conjunctive Use System (Surface Water Augmented with Groundwater)
- Approach 4: Status Quo (communities construct individual lime softening groundwater treatment plants)

So that similar treated water qualities were being evaluated, Approach 2 and Approach 4 assumed that the communities would construct lime softening groundwater treatment plants. A potential driver ultimately requiring lime softened groundwater or the use of surface water is a chloride discharge limit in wastewater.

A finding in the report as it relates to surface water treatment in the vicinity of Ramsey was that *“The Mississippi River has sufficient water quantity to serve the Northwest Metro communities. The water quality in the Mississippi River appears to be acceptable for a conventional surface water treatment plant. St. Cloud, St. Paul, and Minneapolis utilize the Mississippi River as their source of drinking water.”*

The capital cost of a surface water treatment plant is significantly higher than an iron and manganese groundwater treatment plant. Based on costs presented in the report, the project cost for a 10 MGD surface water treatment plant would be \$50 million or more. In addition, the Operation and Maintenance costs of treating surface water is approximately twice as high as iron and manganese treatment.

It should be noted that a surface water treatment plant could provide softened water to the residents of Ramsey; whereas an iron and manganese treatment plant would not provide softened water. However, residents that are concerned about hard water are likely already softening their water with a home softener.

As of the preparation of this report, the Study was still in draft form. When the Study is complete, it will be available to the public on the MCES website. The citation for the report is: *Metropolitan Council. 2020. Northwest Metro Area Regional Water Supply System Study. Prepared by Short Elliott Hendrickson Inc. Metropolitan Council: Saint Paul.*

Because it has been demonstrated that Ramsey should have sufficient groundwater available to meet future demands, a surface water treatment plant is not recommended at this time. A potential Ramsey groundwater treatment plant will be located close enough to the Mississippi River that it could be converted to a surface water treatment plant in the future if it became necessary. It is recommended that surface water features be designed into a potential water treatment plant. The additional cost of the surface water features is approximately \$250,000.

7 Water Treatment

To remove manganese, iron, or hardness from Ramsey’s drinking water, a centralized water treatment plant should be constructed. Adding the necessary processes to treat the water supply at each pump house would not be cost-effective.

7.1 Current and Future Treatment Needs

Many of Ramsey's wells are high in manganese, which has necessitated a solution to reduce the levels due to its health concerns. Ramsey's water is also high in iron and hardness. Ramsey's water otherwise meets all of the primary and aesthetic drinking water standards.

Manganese and iron can be removed with oxidation and sand filtration as discussed in the pilot study in Appendix E. Hardness removal options are discussed in Section 7.5.

Future treatment requirements will depend upon the class of contaminant being treated. Volatile chemicals can typically be removed using an aerator (i.e. gasoline constituents, trichloroethylene [TCE], radon, hydrogen sulfide, etc.). Some organic chemical may be removed using granular activated carbon (potential taste and odor causing contaminants). It may also be possible to add chemical feed systems to remove new contaminants using sand filters (i.e. arsenic, radium). If it is not possible to remove the contaminants by volatilization, carbon filtration, or sand filtration, membrane filters could be necessary (i.e. reverse osmosis). It should be noted that sand filtration is typically required ahead of membrane filters because iron and manganese causes fouling on the membranes.

In addition to potential future contaminants, a water treatment plant could be designed with features that would allow it to be converted to a surface water treatment plant in the future. One of these features would be filter-to-waste piping and valves. Filter-to-waste piping is required for surface water treatment, but is not generally used with groundwater treatment.

Ultimately, having a treatment facility that is flexible and can be retrofitted to meet new potential requirements is very important.

7.2 Treatment Capacity

As discussed in Chapter 4, the maximum day demand ranged from 4.1 to 5.5 MGD in the last 10 years. While the overall maximum day water demand has been flat in the last 10 years, the maximum day demand nearly triples the average day demand. The projected 2040 maximum day water demand is 10.3 MGD.

The recommended capacity of a water treatment plant for Ramsey is 10 MGD under normal conditions with the ability to operate up to 15 MGD for shorter periods. This will allow the City to comfortably treat maximum days through 2040 and possibly beyond.

7.3 Manganese and Iron Removal Options

The most common and most cost effective option for manganese and iron removal is chemical oxidation followed by sand filtration. In groundwater, the manganese and iron ions are in solution. When a strong oxidant is added to the water, it converts the manganese and iron to filterable solids.

The oxidant that is added for iron oxidation is typically oxygen via aeration or chlorine. The chemical oxidant that is added for manganese oxidation is typically sodium permanganate. Chlorine is a less expensive chemical oxidant, but the reaction with manganese is too slow to be used in a filtration process. Options for gravity and pressure filtration are presented later in this chapter.

Other options for iron and manganese removal are chemical oxidation followed by membrane filtration or reverse osmosis. Both of these options are very expensive from a capital cost and operations and maintenance standpoint and are not being considered further.

7.4 Hardness Removal

Hardness in water is caused by excess calcium and magnesium ions in the water. Hard water causes scaling on fixtures and can plug pipes. Hardness can be removed from water on a municipal scale by lime softening or ion exchange softening.

7.4.1 Lime Softening

Lime softening involves adding lime to water to raise the pH to a point where the calcium carbonate is no longer soluble in the water. By forming calcium carbonate precipitate; the calcium can be removed by filtration. A lime softening water treatment plant requires sedimentation, clarification, and filtration and is very expensive. The capital cost of a lime softening water treatment facility for Ramsey could be as much as \$50 million. The operation and maintenance (O&M) of a lime softening water treatment facility would also be significantly more than an iron and manganese removal water treatment facility. Higher O&M for a lime softening plant is due to a larger facility and more chemical processes. It should be noted that a lime softening water treatment plant would also remove manganese and iron, and would not require a separate treatment process.

Due to the high capital and O&M costs associated with a lime softening water treatment plant, it is not recommended for the City of Ramsey.

7.4.2 Ion Exchange Softening

Ion exchange softening involves exchanging calcium and magnesium ions for sodium ions with an ion exchange resin. This is exactly the same process that is used in a home water softener. To regenerate an ion exchange softener, the resin is flushed with a concentrated solution of brine. This regeneration process uses large quantities of salt. A municipal ion exchange water softening system treating 3.5 MGD (Ramsey's 2040 average day demand) would use as much as 6 tons of salt every day.

The capital cost of adding an ion exchange water softening treatment process to a new water treatment facility would be approximately \$5 million. This cost would be in addition to an iron and manganese removal water treatment plant.

The operation cost for salt and wasted water for an ion exchange softening process is approximately \$500 per million gallons of water treated. This is independent of whether it is done by the City or by a resident.

An ion-exchange softening process would add approximately 3 tons of chloride to the wastewater system which is ultimately discharged to the Mississippi River. While the MCE Metro Wastewater Treatment Plant currently meets its discharge limits, chlorides have received more regulatory scrutiny recently. Operating a municipal scale ion exchange softening process may become less feasible in the future due to chlorides in wastewater. In addition, municipal scale ion exchange softening might not be considered environmentally responsible. Due to the higher operation and maintenance costs, potential future regulations, and environmental responsibility, an ion-exchange softening process is not recommended.

7.5 Pilot Study Results

A pilot study was performed by John Thom of SEH of Ramsey's water in January 2020. The Pilot Study Report is included in Appendix E. The objectives of the pilot study were to evaluate the effectiveness of detention time prior to filtration, and to determine the optimal filter media.

The pilot study found no significant difference between direct filtration and utilizing 30 minutes of detention time prior to filtration, and found no significant difference between the silica sand/anthracite and greensand/anthracite filter media. Because the manganese oxide coating on manganese greensand filters is helpful for manganese removal, greensand/anthracite filter media is recommended.

7.6 Filter Sizing

The required filter area is determined by dividing the nominal filtration capacity by a flux rate (filtration rate). Ten States Standards requires sand filtration rates from 2 to 4 gpm / ft². Because the required filtration capacity is 10 MGD under normal operating conditions, the facility will be designed for 10 MGD at 2 gpm / ft². Therefore, if 15 MGD is necessary for short periods of time, the filtration rate will still be in the acceptable range. With a capacity of 10 MGD and a filtration rate of 2 gpm / ft², it is necessary to have 3,200 ft² of filter media. To have reasonable backwash rates and operational flexibility, this will be broken into eight filters.

7.7 Operator Input

Ramsey operators and City Staff toured existing water treatment plants in Andover and Brooklyn Center as part of this feasibility study. Operator feedback from the tours was gathered and incorporated into the building layouts discussed in the following sections.

7.8 Treatment Alternative 1 - Gravity Filter Layout

7.8.1 General

In an iron and manganese gravity filtration system, water to be filtered is pumped, under low pressure, to the treatment facility where it flows by gravity through the various treatment processes. Following the oxidation process, the water flows through the filter cells from top to bottom. As the water passes through the filter media, the insoluble particles of iron and manganese are removed.

As more and more water is filtered, the restriction to flow, created by the accumulation of iron and manganese solids on the media, steadily increases. In a gravity facility, this restriction to flow, called head, is measured in feet of water depth in the filter cells. As the solids accumulate, the depth of water in the filter cells increases. Due to the physical nature of a gravity filter, when the depth of water in a cell reaches its maximum designed head (high water level) backwashing is required. Failure to backwash at the proper time could result in the filter overflowing or poor effluent water quality being produced. Gravity filters are typically constructed of concrete or steel. Steel filters are generally found in smaller water systems. Because of the large size of the filters required for Ramsey, steel filters are not being considered.

The advantages to gravity filtration systems are:

1. Gravity filters provide for more treatment options including aeration and detention without requiring another pumping step. If regulations change or the water becomes contaminated, additional treatment steps can be added to gravity filters.
2. Water from the gravity filters does not go immediately into the distribution system. If problems with the filters occur or if sodium permanganate is overfed (causing pink water), operators have time to react and correct the problem.
3. Gravity filters are open to view and access. This is advantageous in that it enhances the observation, operation and maintenance of the filter functions and components.
4. Gravity filtration systems have a greater amount of flexibility with less disruption during normal maintenance procedures.

The disadvantages to gravity filtration systems are:

1. The facilities tend to have more capital cost than pressure type facilities.
2. Typically requires the facility to be constructed on two floor levels.
3. Provides for less available headloss than pressure facilities which can result in shorter filter run times. Shorter filter run times result in more backwashing which takes a filter out of service.

7.8.2 Building Layout/General Sequence

Gravity filter building layouts are included in Appendix F. The chemical rooms are located on the east side of the building, with exterior doors accessible for deliveries. The electrical, mechanical, high service pump room, and generator rooms are located in close proximity to each other to allow for short conduit runs to motor controls.

The gravity filter layout occurs on two levels to allow for filter height to provide head for the filtering process. The raw water enters the building through the high service pump room where chlorine and potassium permanganate are added. The water travels through the filters by gravity to the clearwell. The water travels from the clearwell to the high service pump chamber where it is pumped into the distribution system. Fluoride, chlorine, and phosphate will be added to the finished water.

7.8.3 Main Level

7.8.3.1 Chemical Rooms

Chemical rooms are clustered on the east side of the building with exterior doors to allow easy access for chemical deliveries. It is expected that chemical rooms will be required for chlorine gas, sodium permanganate, fluoride, phosphate, and possibly polymer to aid in backwash settling.

7.8.3.2 High Service Pump Room

The high service pump room contains the pumps that pump treated water from the clearwell into the distribution system. Because most of the electrical load is located in the high service pump room, it is in close proximity to the electrical room and generator room.

7.8.3.3 Electrical Room

The electrical room contains the motor control equipment and electrical panels. The location of this room in close proximity to the high service pump room, mechanical room, and generator room provide for short conduit and wire runs.

7.8.3.4 Mechanical Room

This room contains the make-up air, dehumidification, and HVAC equipment. The location of this room on an outside wall provides space for air louvers.

7.8.3.5 Blower Room

The blower room contains the filter backwash blower. The backwash blower provides air which is used to help clean the filter media during a backwash.

7.8.3.6 Office/Control Room/Lab

An office/control room/lab is provided for operators to have a SCADA computer to monitor and control the water system. A lab sink and desktop analyzer will be provided to allow operators to monitor water quality. The office is located in the front of the building next to the entrance, and has lots of windows for natural light.

7.8.3.7 Generator Room

A standby generator will be located in the generator room. The generator is capable of running the water treatment plant in the event of a power outage or possibly for peak shaving (peak shaving requires additional emissions compliance). The service entrance and automatic transfer switch are located in this room. Two exterior walls are provided for intake and exhaust louvers.

7.8.4 Upper Level

The upper level is depicted on the Upper Level Floor Plan in Appendix F. The upper level consists of filters and walkways. Windows will be provided in the filter room to allow for natural lighting. Walkways will be provided around the filters to allow the plant operator to inspect the operating conditions of the filters. Control panels (fixed or mobile) will be provided to allow the operators to manually initiate backwashes from the upper level.

7.8.5 Clearwell

A clearwell is located adjacent to the gravity filter treatment facility. The clearwell provides storage and operational flexibility (the box shown on Figure 1A in Appendix F represents 1 million gallons of underground storage). This storage is necessary to (1) maintain a volume of water for backwashing filter cells, (2) to provide the flexibility to treat water at a rate different than the raw water pumping rate, and (3) to provide additional storage for the distribution system.

To provide operational flexibility and to supplement system storage, a 1 million gallon clearwell is the minimum size recommended.

7.9 Treatment Alternative 2 – Pressure Filter Layout

7.9.1 General

In an iron and manganese pressure filtration system, water to be filtered is pumped directly to, and through, the facility's components under pressure. Oxidation occurs inside the pipelines and filter vessels upstream of the filter media. Following the oxidation process, the water flows through the filter vessels from top to bottom. As the water passes through the filter media, the insoluble particles of iron and manganese are removed from the flow.

As more and more water is filtered, the restriction to flow, created by the accumulation of iron and manganese solids on the media, steadily increases. In a pressure facility, this restriction to flow, called head, is measured in pounds per square inch (psi). As the solids accumulate, the headloss, or difference in pressures between the top and bottom sides of the filter media, increases. Due to the design and construction of pressure filters, headloss can be driven as high as 15 psi, although 5 to 6 psi is the preferred upper limit to ensure water quality.

The advantages to pressure filtration systems are:

1. The facilities tend to have less capital cost than gravity facilities.
2. Plants are typically constructed on one floor level.
3. Provide for greater available headloss than gravity facilities which can result in longer filter run times than a comparably sized gravity facility. Longer filter run times require less backwashing which keeps a filter in service longer.

The disadvantages to pressure filtration systems are:

1. Pressure filter systems have less ability to add additional treatment processes (aeration, detention) if regulations or water quality changes.
2. Closed from view and difficult to access internally. This prevents observation of the systems operation. Condition of the filter media and flow distribution during a backwash cycle cannot be readily monitored.
3. Pressure filters are constructed out of steel and require periodic blasting and painting.
4. Inspection of the pressure filters requires entry into a confined space which is a safety hazard.

7.9.2 Building Layout/General Sequence

Pressure filter building layouts are included in Appendix G. The chemical rooms are located on the east side of the building, with exterior doors accessible for deliveries. The electrical, mechanical, and generator rooms are located in close proximity to each other to allow for short conduit runs and motor controls.

The pressure filter layout occurs on one level. The raw water enters the building in pressure pipe and chlorine and permanganate are added. The water goes directly through the filters under pressure where the iron and manganese are removed. Fluoride, chlorine, and phosphate will be added to the finished water.

7.9.3 Main Level

7.9.3.1 Chemical Rooms

Chemical rooms are clustered on the east side of the building with exterior doors to allow easy access for chemical deliveries. It is expected that chemical rooms will be required for chlorine gas, sodium permanganate, fluoride, phosphate, and possibly polymer to aid in backwash settling.

7.9.3.2 Electrical Room

The electrical room contains the motor control equipment and electrical panels. The location of this room in close proximity to the mechanical room and generator room provide for short conduit and wire runs.

7.9.3.3 Mechanical Room

This room contains the make-up air, dehumidification, and HVAC equipment. The location of this room on an outside wall provides space for air louvers.

7.9.3.4 Blower Room

The blower room contains the filter backwash blower. The backwash blower provides air which is used to help clean the filter media during a backwash.

7.9.3.5 Office/Control Room/Lab

An office/control room/lab is provided for operators to have a SCADA computer to monitor and control the water system. A lab sink and desktop analyzer will be provided to allow operators to monitor water quality. The office is located in the front of the building next to the entrance, and has lots of windows for natural light.

7.9.3.6 Generator Room

A standby generator will be located in the generator room. The generator is capable of running the water treatment plant in the event of a power outage or possibly for peak shaving (peak shaving requires additional emissions compliance). The service entrance and automatic transfer switch are located in this room. Two exterior walls are provided for intake and exhaust louvers.

7.10 Backwash Alternatives

Sand filters (gravity and pressure) require periodic backwashing to remove solids from the filters. Backwashing one of the filters (either gravity or pressure) will consume between 40,000 and 70,000 gallons of water. After a backwash, the solids are allowed to settle and the clear water is recycled back to the filters. This can be done with backwash tanks or lamella plate settlers as discussed below.

7.10.1 Backwash Alternative 1 – Backwash Tanks

Backwash tanks simply involve discharging the backwash water to a tank where the water is allowed to settle for a period of time (typically 8 hours). Clear water is decanted from the backwash tank and recycled to the beginning of the treatment process. A backwash polymer may be utilized to increase settling efficiency.

To allow for more than one filter to be backwashed in one day, multiple backwash tanks are required. To provide for efficient operation, three backwash tanks are recommended.

7.10.2 Backwash Alternative 2 – Lamella Plate Settlers

Lamella settling is a process that receives continuous flow from the backwash tank, and provides high rate thickening of the sludge, and reclaims decanted clear water to the beginning of the treatment train. High rate inclined plate settlers typically thicken backwash sludge to approximately 0.5 to 1.5% solids prior to discharging to either a sludge storage tank for further thickening, or directly to the sanitary sewer.

Backwash waste water is pumped from the backwash tank directly into the gravity settler, alleviating settling time. A coagulant is added immediately, as the water flows through a flash mixer and into a flocculation tank. The coagulated sludge then flows into a series of inclined plates, the surfaces which collect the sludge and direct it to a sludge hopper. The clear effluent flows out the overflow and is recycled to the raw water. The inclined orientation of the plates allows for more surface area for the solids to settle upon, while limiting the total space taken up by the equipment.

As with treatment process equipment in general, redundancy is recommended so that in the event that one lamella settler is down, settling operations can continue seamlessly. Therefore, one single lamella settler is not recommended.

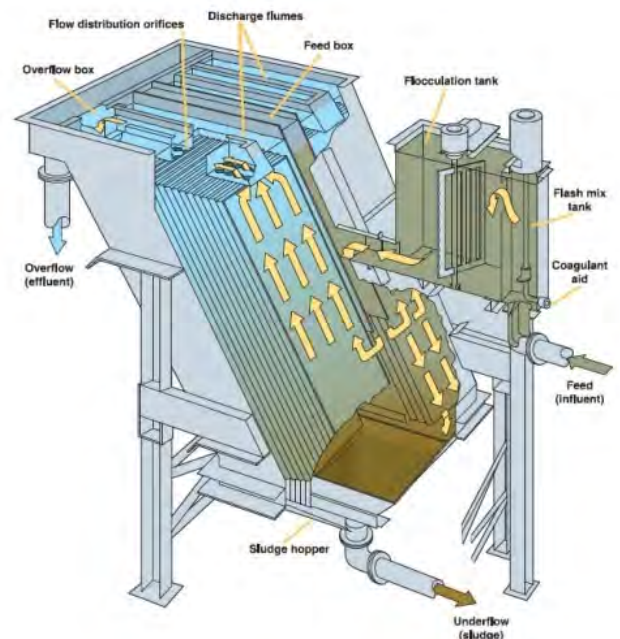

7.10.3 Backwash Alternative Comparison

The advantages of lamella plate settlers is that they do not require settling time prior to recycling the backwash water. This eliminates the need for batch processing of backwash water from backwash tanks and provide significant operational flexibility. Backwash tanks can dictate when and if a filter can be backwashed.

Lamella plate settlers waste between 60 and 900 gallons per million gallons of water treated, depending upon whether a sludge holding tank is utilized. Backwash tanks waste between 750 and 5,000 gallons of water per million gallons of water treated.

Because lamella plate settlers provide significantly more operational flexibility and waste less water, lamella plate settlers are recommended for Ramsey.

8 Architectural Design

The City of Ramsey's goal for the water treatment facility is to provide a building that fits with adjacent structures, includes cost effective sustainable design features, is operator friendly, and provides a civic presence to the public.

The water treatment functions of the building will be constructed of poured in-place concrete foundations with masonry, brick, and stone façade. A glass atrium is proposed as an architectural feature and to provide additional natural light. Architectural features from adjacent structures will be incorporated into the design.

For walls that are less visible to the public, cost-effective insulated load bearing precast wall panels will be use. The roof will be constructed of precast concrete double 'T's for the roof structure of the filter room which allows for a greater clear spans and more daylighting.

Sustainable architectural features will include natural daylighting throughout including the filter room, low maintenance poured-in-place and plant precast concrete structure and wall panels, building insulation which surpasses the current energy code. Rain gardens and low maintenance landscaping features can be included in the site design.

An architectural rendering that further demonstrates the design concept for the Fire Station Site is included in Appendix H. If the water treatment plant is constructed elsewhere the architectural treatments will be modified to fit with the adjacent structures.

9 Utility Space Needs Evaluation

City staff was solicited for additional space needs and features in the water treatment plant building in addition to the necessary filters and process rooms. The additional features requested in the building included a training room, and a separate laboratory. An optional 8,000 square foot garage is also included in some of the building layouts.

10 Water Treatment Plant Site Alternatives and Evaluation

Four alternatives for a new water treatment plant site were provided by the City. These alternatives include the Fire Station Site, Public Works Site, Water Shop Site, and Vacant City Property Site. These sites are shown on Figure 1 in Appendix I and are discussed below.

The watermain costs in the following sections assume that watermain is primarily installed within public utility easements, City-owned properties, or in County/City right-of-way next to roads, either in the boulevard or under paved trails.

The costs shown in this section are for purposes of comparing alternatives and do not contain contingency or indirect costs. The costs for the selected alternative are incorporated into the overall project costs presented in Section 12 where contingency and indirect costs are added.

10.1 Fire Station Site

The Fire Station Site is currently private property and would need to be acquired by the City. It was determined that a 3.2-acre site would be sufficient for the water treatment plant and a future

expansion to 20 MGD. Portions of the water treatment plant would be constructed on the existing City-owned Fire Station property. A water treatment plant layout for the Fire Station Site is shown on Figure 4 in Appendix I.

10.1.1 Raw Watermain and Costs – Fire Station Site

The raw watermain required to construct a water treatment plant at the Fire Station Site is shown on Figure 2 in Appendix I. The water main and site acquisition costs are included in Table 12. Because the Fire Station Site is remote from other City garage facilities, it is assumed that a water treatment plant garage is needed.

Table 12 – Fire Station Site Costs

Item	Unit	Est. Quantity	Unit Price	Cost ¹
24" Raw Watermain	LF	3950	\$230	\$908,500
24" Road Crossing (Armstrong and Bunker Lake Blvd) - Jacked Casing	LF	400	\$525	\$210,000
16" Raw Watermain (Bunker Lake Blvd) - Jacked Casing	LF	100	\$425	\$42,500
12" Raw Watermain	LF	1850	\$125	\$231,250
Land Purchase	LS	1	\$750,000	\$750,000
Garage	LS	1	\$1,450,000	\$1,450,000
Total				\$3,592,250

¹ Costs are for comparison of alternatives and are not meant to represent the full project costs.

10.2 Public Work Site

The City is in the process of constructing a new Public Works Facility on a 19.9-acre parcel shown on Figure 1 in Appendix I. The proposed water treatment plant site is a 3.5-acre portion in the northeast corner of the Public Works Site. The northwest corner of the Public Works Site will remain available for other uses or development as it offers the best visibility and has access to both 143rd Avenue and Jasper Street. In addition, constructing the water treatment plant in the northeast corner of the Public Works Site will allow the City to control access to the existing cemetery on the site. A water treatment plant layout for the Public Works Site is shown on Figure 5 in Appendix I.

10.2.1 Raw and Finished Watermain Costs – Public Works Site

The raw and finished watermain required to construct a water treatment plant at the Public Works Site is shown on Figure 3 in Appendix I. The watermain costs are included in Table 13. Because a new Public Works building is being constructed on the Public Work Site, it is assumed that a new garage is not needed with the water treatment plant.

Table 13 – Public Works Site Costs

Item	Unit	Est. Quantity	Unit Price	Cost ¹
24" Raw Watermain	LF	7300	\$230	\$1,679,000
24" Road Crossing (Ramsey Blvd and Bunker Lake Blvd) - Jacked Casing	LF	400	\$525	\$210,000
24" Finished Watermain	LF	3800	\$230	\$874,000
20" Raw Watermain	LF	1300	\$185	\$240,500
16" Raw Watermain	LF	1750	\$165	\$288,750
16" Raw Watermain (Armstrong Blvd) - Jacked Casing	LF	100	\$425	\$42,500
Well 8 Meter Vault	LS	1	\$90,000	\$90,000
Total				\$3,424,750
¹ Costs are for comparison of alternatives and are not meant to represent the full project costs.				

10.3 Water Shop Site

The Water Shop Site for the water treatment plant is City-owned property on the west side of Jasper Street, across the street from the new Public Works Facility. The water treatment plant would require approximately 3.5 acres of land. The current City water operations shop is located on this site. Construction of the water treatment plant on the Water Shop Site would require demolition of the existing water operations shop and abandonment of 142nd Ave NW. A water treatment plant layout for the Water Shop Site is shown on Figure 6 in Appendix I.

10.3.1 Raw and Finished Watermain Costs – Water Shop Site

The raw and finished watermain required to construct a water treatment plant at the Water Shop Site is shown on Figure 3 in Appendix I. The water main costs are included in Table 14. Because a new Public Works building is being constructed across the street from the Water Shop Site, it is assumed that a new garage is not needed with the water treatment plant. Costs to demolish the existing water operations shop are not included in Table 14.

Table 14 – Water Shop Site Costs

Item	Unit	Est. Quantity	Unit Price	Cost ¹
24" Raw Watermain	LF	8627	\$230	\$1,984,210
24" Road Crossing (Ramsey Blvd and Bunker Lake Blvd) - Jacked Casing	LF	400	\$525	\$210,000
24" Finished Watermain	LF	3800	\$230	\$874,000
20" Raw Watermain	LF	1300	\$185	\$240,500
16" Raw Watermain	LF	1750	\$165	\$288,750
16" Raw Watermain (Armstrong Blvd) - Jacked Casing	LF	100	\$425	\$42,500
Well 8 Meter Vault	LS	1	\$90,000	\$90,000
Total				\$3,729,960
¹ Costs are for comparison of alternatives and are not meant to represent the full project costs.				

10.4 Vacant City Property Site

The City owns a vacant 4.1-acre parcel located on the east side of Ramsey Blvd NW, west of the Public Works Site shown on Figure 1 in Appendix I. The 4.1-acre parcel would be sufficient to construct Ramsey's water treatment plant. A water treatment plant layout for the Vacant City Property Site is shown on Figure 7 in Appendix I.

10.4.1 Raw and Finished Watermain Costs – Vacant City Property Site

The raw and finished watermain required to construct a water treatment plant at the Vacant City Property Site is shown on Figure 3 in Appendix I. The water main and garage costs are included in Table 15. Because the Vacant City Property Site is not on or adjacent to the new Public Works Site, it is assumed that a garage is needed.

Table 15 – Vacant City Property Site Costs

Item	Unit	Est. Quantity	Unit Price	Cost ¹
24" Raw Watermain	LF	9288	\$230	\$2,136,240
24" Road Crossing (Ramsey Blvd and Bunker Lake Blvd) - Jacked Casing	LF	400	\$525	\$210,000
24" Finished Watermain	LF	3800	\$230	\$874,000
20" Raw Watermain	LF	1300	\$185	\$240,500
16" Raw Watermain	LF	1750	\$165	\$288,750
16" Raw Watermain (Armstrong Blvd) - Jacked Casing	LF	100	\$425	\$42,500
Well 8 Meter Vault	LS	1	\$90,000	\$90,000
Garage	LS	1	\$1,450,000	\$1,450,000
Total				\$5,331,990
¹ Costs are for comparison of alternatives and are not meant to represent the full project costs.				

10.5 Water Treatment Plant Site Evaluation and Recommendation

The City had previously planned to locate a surface water treatment plant at the Fire Station site. Some of the raw watermain is in place and it is convenient for metering Well 8. However, the Fire Station site is remote from other Public Works facilities, would have operational inefficiencies, and would require building a garage. The Fire Station site would also require the City to purchase land. Due to the construction of the garage and purchasing land, the Fire Station site is more expensive than the Public Works site.

The Public Works site requires more new raw and finished watermain than the Fire Station site, but because it is on the site of the Public Works Facility that is currently under construction it would not require a garage and could share an emergency generator and security infrastructure with the Public Works Facility. Having multiple public works facilities on the same site also increases operational efficiencies. The Public Works Site is already owned by the City and doesn't require the purchase of private property. If a garage is not included with the water treatment plant, the Public Works Site is the least expensive option.

The Water Shop site requires more new raw and finished watermain than the Fire Station or Public Works sites. It also requires that the existing water operations shop be demolished and 142nd Ave NW be removed and abandoned. Because it is adjacent to the Public Works Site, a garage would not be necessary at the Water Shop Site. Due to the additional watermain and a reduced ability to share an emergency generator and security infrastructure, the Water Shop site is more expensive than the Public Works Site.

The Vacant City Property Site requires more new finished and raw watermain than the Water Shop Site, and more yet than the Public Works Site. In addition, the Vacant Property Site doesn't offer the ability to share an emergency generator or security infrastructure as the Public Works Site does, and doesn't offer operational efficiencies. A garage would also be necessary. The Vacant City Property Site is the most expensive of the four sites evaluated.

Table 16 – Alternate Site Cost Comparison

Alternate WTP Sites Considered	Cost ¹
Fire Station Site	\$3,592,250
Public Works Site	\$3,424,750
Water Shop Site	\$3,729,960
Vacant Property Site	\$5,331,990
¹ Costs are for comparison of alternatives and are not meant to represent full project costs.	

In January of 2020, the City of Ramsey's Planning Commission, Economic Development Authority, and Public Works Committee all voted unanimously to recommend City Council approval to construct the water treatment plant on the Public Works site. Stall also recommends the Public Works Site because it offers the least expensive overall construction cost, and also offers the greatest operational efficiencies, which in turn will reduce future operational costs.

11 Impacts to Nearby Properties

The water treatment plant is proposed to be constructed on the new Public Works Site as shown on Figure 5 in Appendix I. The Public Works site is in an industrial area of Ramsey and will already be used for a municipal public works building. Opposition from the neighboring properties to a new water treatment plant is not anticipated.

Water treatment plants are quiet neighbors with relatively little traffic. A standby generator will be part of the water treatment plant project, but it is proposed to be located inside the building and will have sound attenuation. Sound complaints from neighbors are not anticipated.

The operators will visit the plant daily and chemical deliveries will likely be made approximately once per week. Construction complaints are not expected since the water treatment plant is in an industrial neighborhood.

12 Capital Cost Opinions

Feasibility level opinions of probable cost (OPC) broken down by construction category were prepared for the gravity and pressure filtration alternatives. A breakdown of these costs by

division are included in Appendix J. Tables 17 and 18 present the capital costs for the gravity and pressure filter treatment plants.

Table 17 – Capital Cost Opinion Summary
Gravity Filter Water Treatment Plant

Item	Cost
Water Treatment Plant:	\$26,060,000
Construction Contingency (10%):	\$2,606,000
Preliminary Construction Cost:	\$28,670,000
Engineering/Construction Admin (12%)	\$3,440,000
Legal/Admin (1%)	\$287,000
Total Estimated Project Cost:	\$32,400,000

Table 18 – Capital Cost Opinion Summary
Pressure Filter Water Treatment Plant

Item	Cost
Water Treatment Plant:	\$24,766,000
Construction Contingency (10%):	\$2,477,000
Preliminary Construction Cost:	\$27,240,000
Engineering/Construction Admin (12%)	\$3,268,800
Legal/Admin (1%)	\$272,000
Total Estimated Project Cost:	\$30,780,000

An optional 8,000 square foot garage could be added to either water treatment plant alternative for a project cost of approximately \$1.64 million.

13 Life Cycle Cost Opinions

Life cycle costs represent the total cost of owning the treatment plants for 50 years and include capital cost, equipment replacement, labor, gas, chemicals, insurance, electricity, and annual equipment repair. Detailed life cycle cost tables are included in Appendix K.

The life cycle costs presented in Table 19 and Table 20 assume a 20-year financing period on the capital costs with 2% interest rates and 2.75% inflation.

Operating the water treatment plant is not anticipated to require additional Staff. While Staff will need to visit the plant on a daily basis to operate and maintain it, this time will generally be offset by the time Staff currently spends operating and maintaining the six municipal wells and three pump houses within The COR.

Table 19 – 50-Year Life Cycle Cost Summary
Gravity Filter Water Treatment Plant

Item	50-Year Life Cycle Cost	Annual Cost
Capital Project Costs	\$32,400,000	\$1,981,478
Equipment Replacement	\$9,694,858	\$308,522
Labor	\$6,488,398	\$110,000
Gas	\$1,179,709	\$20,000
Chemicals	\$6,488,398	\$110,000
Insurance	\$1,769,563	\$30,000
Electricity	\$6,783,325	\$115,000
Equipment Repair	\$7,078,253	\$120,000
Total 50 Year Life Cycle Cost	\$71,880,000	

Table 20 – 50-Year Life Cycle Cost Summary
Pressure Filter Water Treatment Plant

Item	50-Year Life Cycle Cost	Annual Cost
Capital Project Costs	\$30,780,000	\$1,882,404
Equipment Replacement	\$13,985,687	\$445,069
Labor	\$6,488,398	\$110,000
Gas	\$1,179,709	\$20,000
Chemicals	\$6,488,398	\$110,000
Insurance	\$589,854	\$10,000
Electricity	\$6,193,471	\$105,000
Equipment Repair	\$9,732,597	\$165,000
Total 50 Year Life Cycle Cost	\$75,440,000	

14 Alternative Evaluation & Recommendation

The two options for removing manganese from Ramsey’s drinking water that have been evaluated include gravity filters and pressure filters.

The capital cost of the pressure filter treatment plant is slightly less than the gravity filter treatment plant (\$30.8 million versus \$32.4 million). However, the life cycle cost of the pressure filter treatment plant is more than the gravity filter treatment plant (\$75.4 million versus \$71.9 million). The pressure filter treatment plant has a higher life cycle cost due to the expense of painting and maintaining the steel filters; whereas concrete gravity filters require very little maintenance.

In addition to having lower life cycle costs, gravity filters have other advantages over pressure filters including:

- Gravity filters provide for more treatment options including aeration and detention without requiring another pumping step. If regulations change or the water becomes contaminated, additional treatment steps can more easily be added to gravity filters.
- Water from the gravity filters does not go immediately into the distribution system. If problems with the filters occur or if sodium permanganate is overfed (causing pink water), operators have time to react and correct the problem.
- Gravity filters are open to view and access. This enhances the observation, operation and maintenance of the filter functions and components.
- Gravity filtration systems have a greater amount of flexibility with less disruption during normal maintenance procedures.
- Gravity filters could potentially be converted from groundwater to surface water in the future if it became necessary.

A gravity filter treatment plant is the recommended alternative due to the advantages it offers at a comparable construction cost and reduced life-cycle cost.

15 Funding

Water treatment plant projects are commonly funded using general obligation bonds or loans and paid for using water rates. The following sections describe a low interest loan program and example grants opportunities. Another option would be to request bonding through the State.

15.1 Drinking Water Revolving Fund Loan

The Minnesota Drinking Water Revolving Fund (DWRF) loan program provides low interest loans to communities that qualify. DWRF loans typically have interest rates that are lower than other loans or bonds available to communities.

To qualify for a drinking water revolving fund loan, a proposal is written to place the project on the Project Priority List (PPL). The PPL ranks projects by factors including the type of project, a community's financial need, and primary contaminant exceedances. Once a City has a project on the PPL and intends to proceed with construction, the project is placed on the Intended Use Plan (IUP). Projects on the IUP are funded based upon their ranking. Not all projects on the IUP are funded.

Based upon Ramsey's financial status discussed in Section 16, the DWRF program may not be desirable based upon the fact that the City could likely receive a lower interest rate on its own, and due to the administrative requirements and loan restrictions.

15.2 Grants

Grants are available for some water projects but are most commonly given to communities that have a financial hardship. The City of Ramsey would likely not qualify.

One potential grant program that is not tied to financial need is the Clean Water Fund Grant administered through the Minnesota Board of Water and Soil Resources. Clean Water funds may only be spent to protect, enhance, and restore water quality in lakes, rivers, and streams and to protect groundwater from degradation. A total of \$2,158,000 in grants was

awarded in FY2020 for 10 projects related to source water protection. All of the recipient organizations were counties, watershed districts, or conservation districts.

A smaller grant opportunity through the Clean Water Fund is a Source Water Protection grant that is administered through the Minnesota Department of Health. A Source Water Protection Grant is typically tied to a goal in a Community's Wellhead Protection Plan. A Source Water Protection Grant has a maximum value of \$10,000.

16 Effect on Water Rates

The City of Ramsey currently has a minimum quarterly water rate of \$42.15. This rate covers the first 15,000 gallons of water used per quarter. After the first 15,000, the cost per 1,000 of water used gets progressively more expensive. This is referred to as a conservation water rate because it discourages the use of more water.

According to the Ramsey Finance Director, the City of Ramsey has approximately \$25 million set aside for a water treatment plant project, which was collected from Municipal water users for this specific purpose. The City of Ramsey currently raises its water rates 2.5% per year. If the City were to bond for the remainder of the water treatment plant project costs, the City would need to explore water rate impacts. For instance, if water rates were raised at a rate of 5% per year for 4 years, the resulting minimum quarterly rate in 2025 would be \$51.23. This could also pay for additional operation and maintenance costs.

17 Public Involvement

Having informed and engaged residents is important to the success of a major municipal project. To engage residents, the following public involvement activities are recommended:

- Publish information describing the water issues and proposed water treatment plant project on the City's website in March 2020, and in the March-April edition of the Ramsey Resident.
- Send information mailers to residents in March 2020 describing the water issues and proposed water treatment plant project. Consider including discussion about municipal scale water softening, the respective costs to the public, and the fact that many people already own in-home water softeners.

18 Schedule

If the City elects to proceed with a water treatment plant project, the proposed project schedule could be as follows:

<u>Item</u>	<u>Completion Date</u>
Public Involvement	March 2021 – April 2021
Preparation of Plans	May 2021 – September 2021
Ad for Bid	October 2021
Bid Opening	November 2021
Construction Start	December 2021
Construction Complete	June 2023

However, Anoka County is planning “interim” improvements to Bunker Lake Boulevard between Armstrong Boulevard and Sunfish Lake Boulevard in 2021 to improve operations and safety in anticipation of traffic volumes doubling while planned improvements to Highway 10 are constructed between 2022 and 2025. Therefore, to construct the raw and finished watermain associated with the water treatment plant project as cost-effectively as possible, plans and specifications for the raw and finished watermain improvements are recommended to be prepared and bid in conjunction with Anoka County’s proposed improvements to Bunker Lake Boulevard.

Appendix A

Existing Water System Map

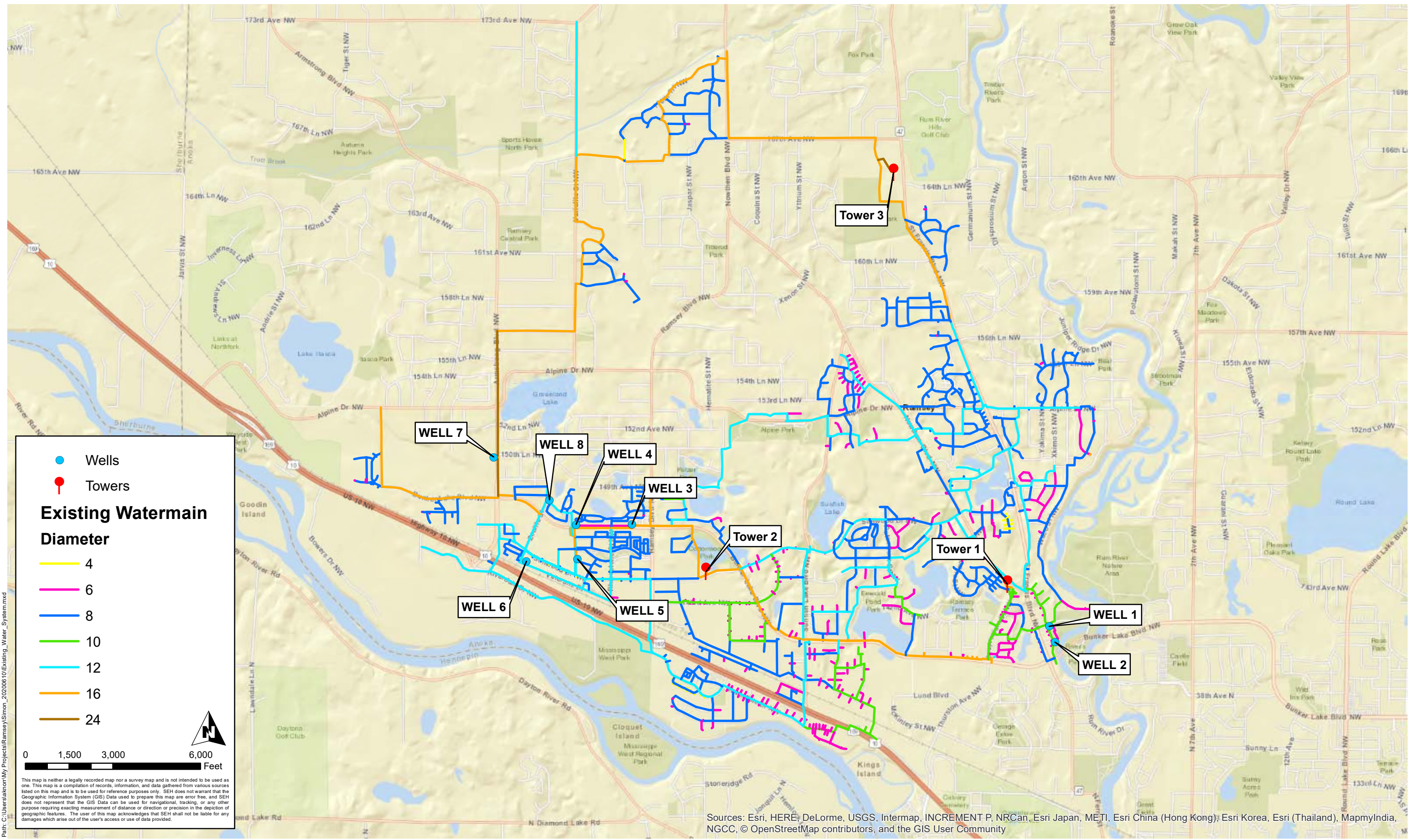

EXISTING WATER SYSTEM
 Ramsey, Minnesota

FIGURE 1
 Existing Water System

Appendix B

Modeling

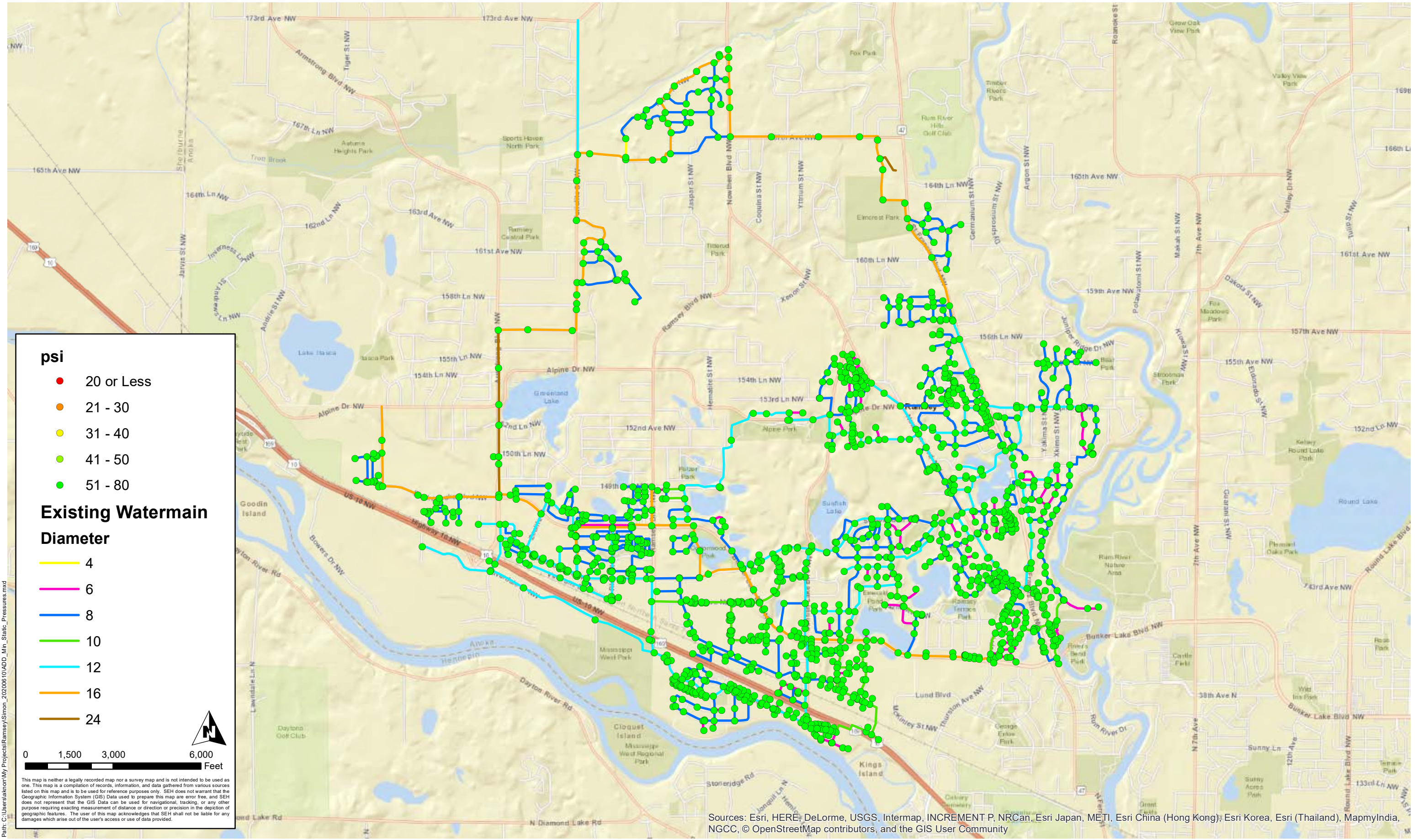

psi

- 20 or Less
- 21 - 30
- 31 - 40
- 41 - 50
- 51 - 80

Existing Watermain Diameter

- 4
- 6
- 8
- 10
- 12
- 16
- 24

0 1,500 3,000 6,000 Feet

This map is neither a legally recorded map nor a survey map and is not intended to be used as one. This map is a compilation of records, information, and data gathered from various sources listed on this map and is to be used for reference purposes only. SEH does not warrant that the Geographic Information System (GIS) Data used to prepare this map are error free, and SEH does not represent that the GIS Data can be used for navigational, tracking, or any other purpose requiring exacting measurement of distance or direction or precision in the depiction of geographic features. The user of this map acknowledges that SEH shall not be liable for any damages which arise out of the user's access or use of data provided.

Sources: Esri, HERE, DeLorme, USGS, Intermap, INCREMENT P, NRCan, Esri Japan, METI, Esri China (Hong Kong), Esri Korea, Esri (Thailand), MapmyIndia, NGCC, © OpenStreetMap contributors, and the GIS User Community

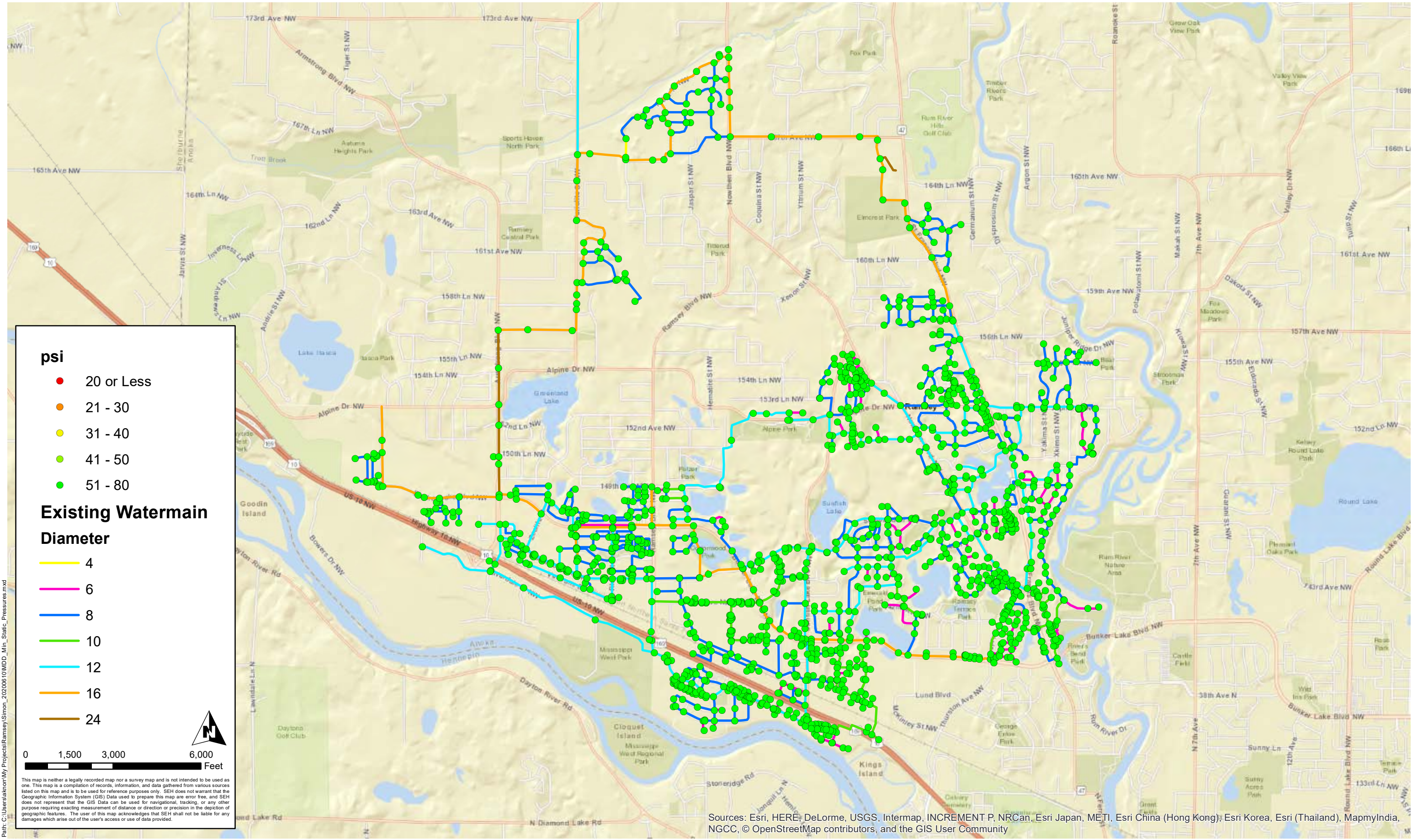

Path: C:\Users\akrom\My Projects\Ramsey\Simon_20200610\MDD_Min_Static_Pressures.mxd

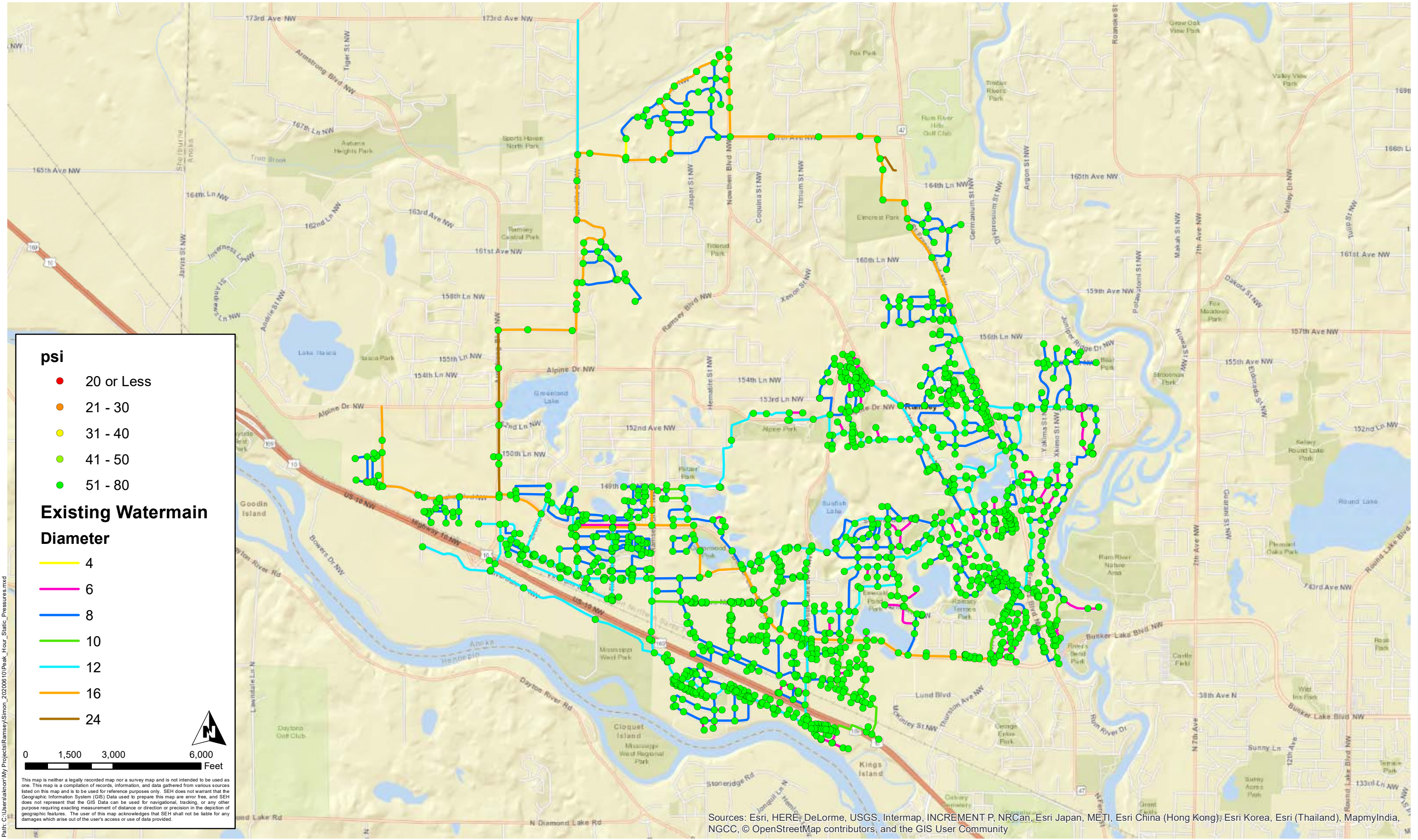

Path: C:\Users\akrom\My Projects\Ramsey\Simon_20200610\Peak_Hour_Static_Pressures.mxd

EXISTING PEAK HOUR STATIC PRESSURE
 Ramsey, Minnesota

FIGURE 3
 Minimum Pressures

FIGURE 4

Existing System ADD 24-Hour Simulation Well and Tower Operation

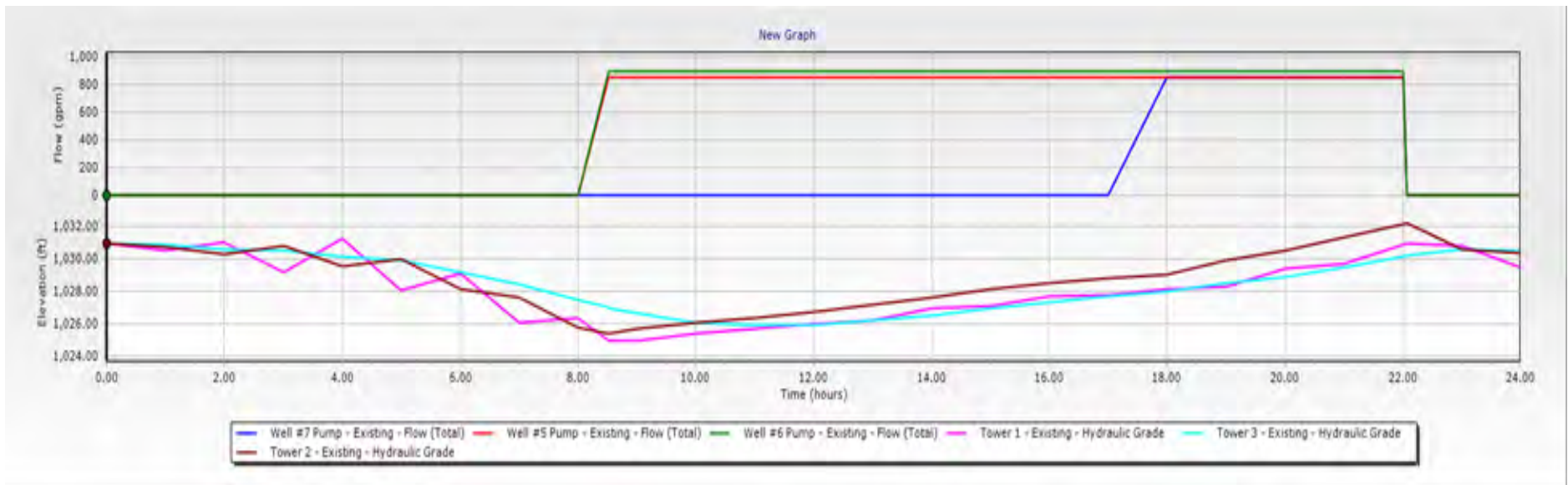
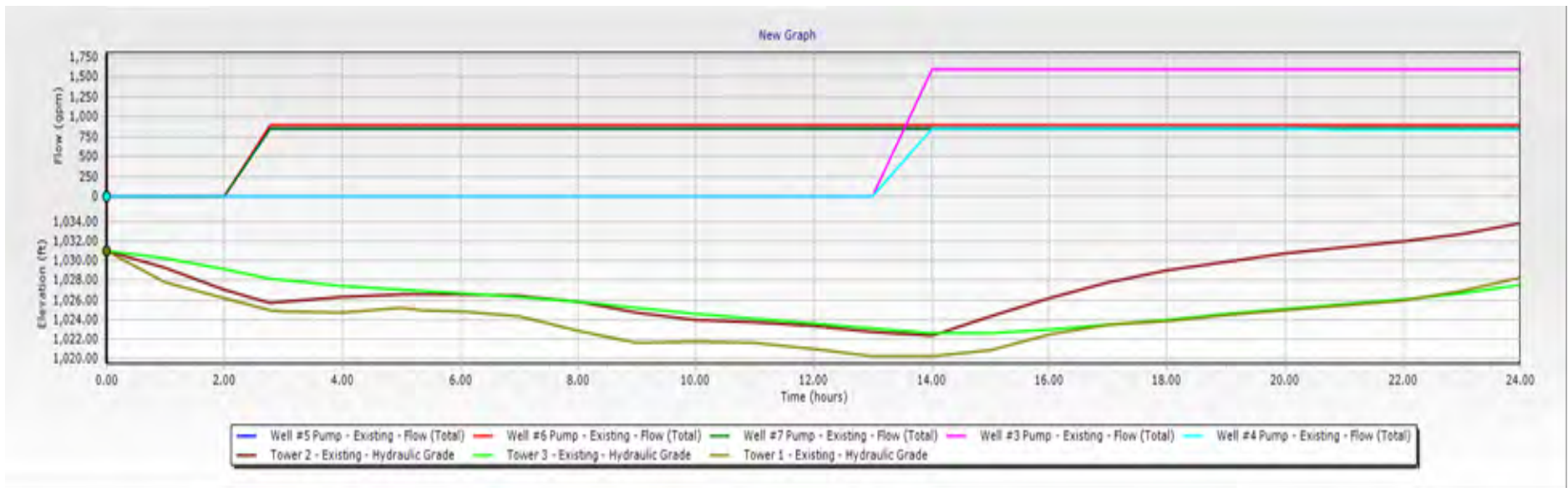
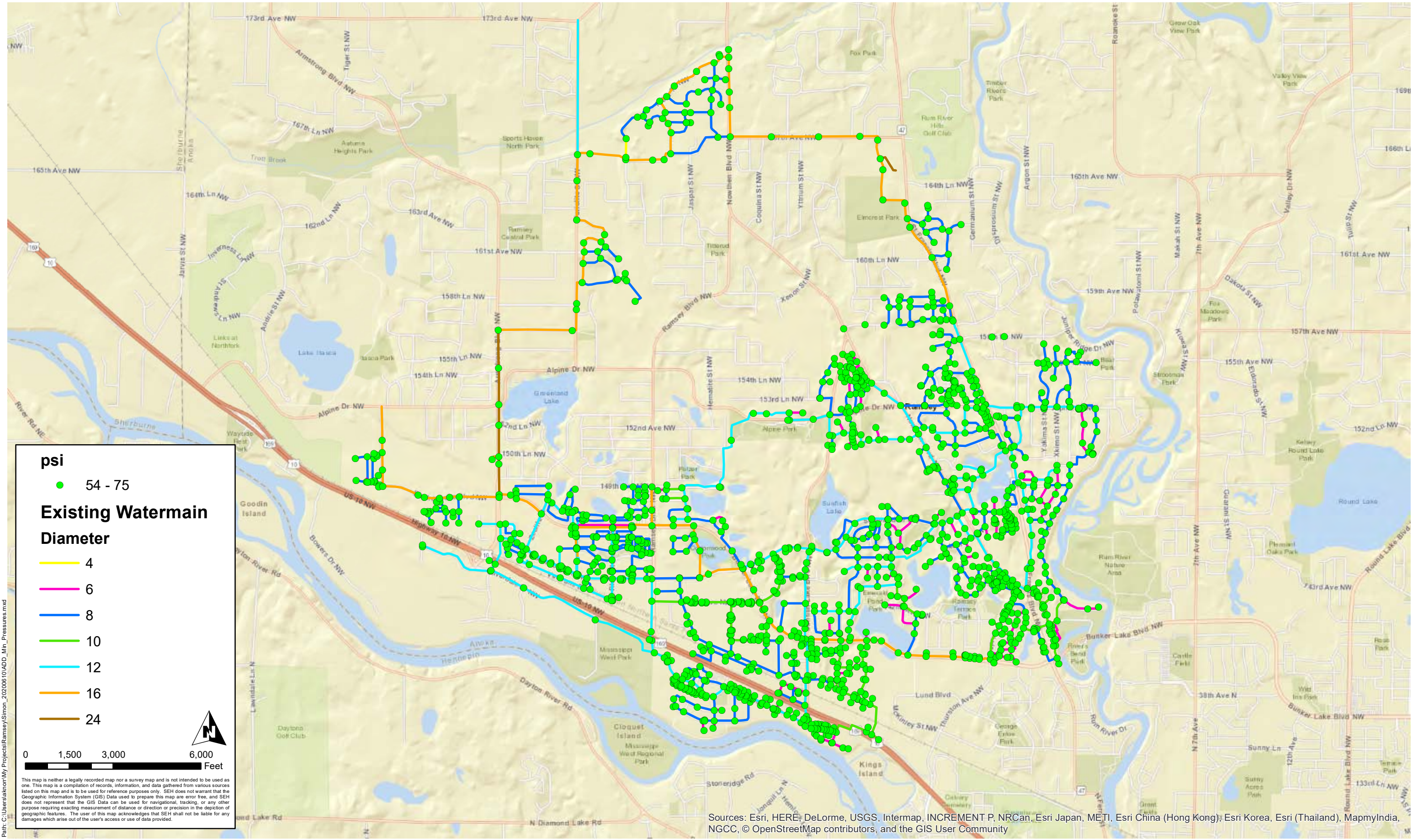

FIGURE 5

Existing System MDD 24-Hour Simulation Well and Tower Operation





psi

- 54 - 75

Existing Watermain Diameter

- 4
- 6
- 8
- 10
- 12
- 16
- 24

0 1,500 3,000 6,000 Feet

This map is neither a legally recorded map nor a survey map and is not intended to be used as one. This map is a compilation of records, information, and data gathered from various sources listed on this map and is to be used for reference purposes only. SEH does not warrant that the Geographic Information System (GIS) Data used to prepare this map are error free, and SEH does not represent that the GIS Data can be used for navigational, tracking, or any other purpose requiring exacting measurement of distance or direction or precision in the depiction of geographic features. The user of this map acknowledges that SEH shall not be liable for any damages which arise out of the user's access or use of data provided.

Sources: Esri, HERE, DeLorme, USGS, Intermap, INCREMENT P, NRCan, Esri Japan, METI, Esri China (Hong Kong), Esri Korea, Esri (Thailand), MapmyIndia, NGCC, © OpenStreetMap contributors, and the GIS User Community

EXISTING ADD 24 HOUR EPS MINIMUM PRESSURES
 Ramsey, Minnesota

FIGURE 6
 Minimum Pressures

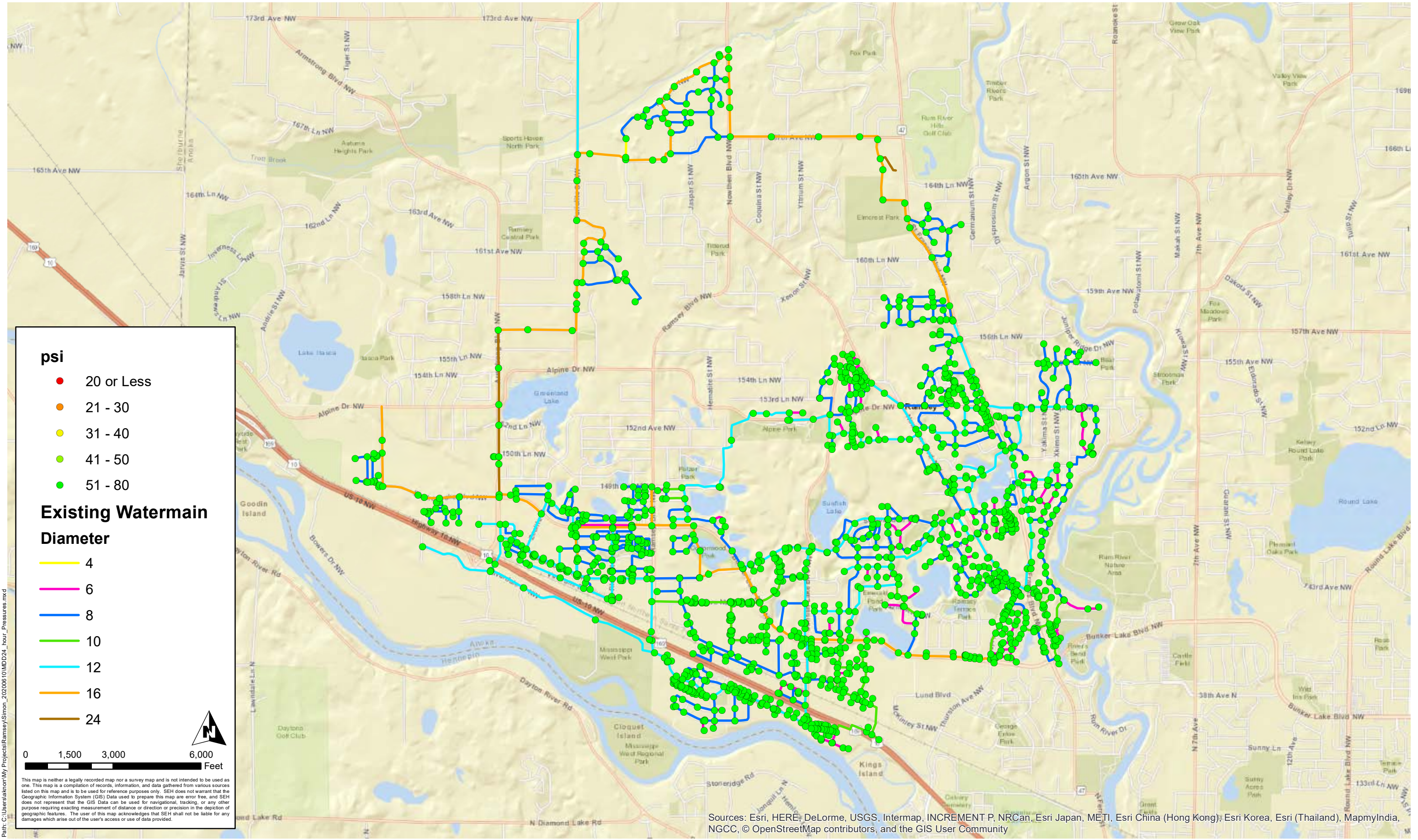

EXISTING MDD 24 HOUR EPS MINIMUM PRESSURES
Ramsey, Minnesota

FIGURE 7
Minimum Pressures

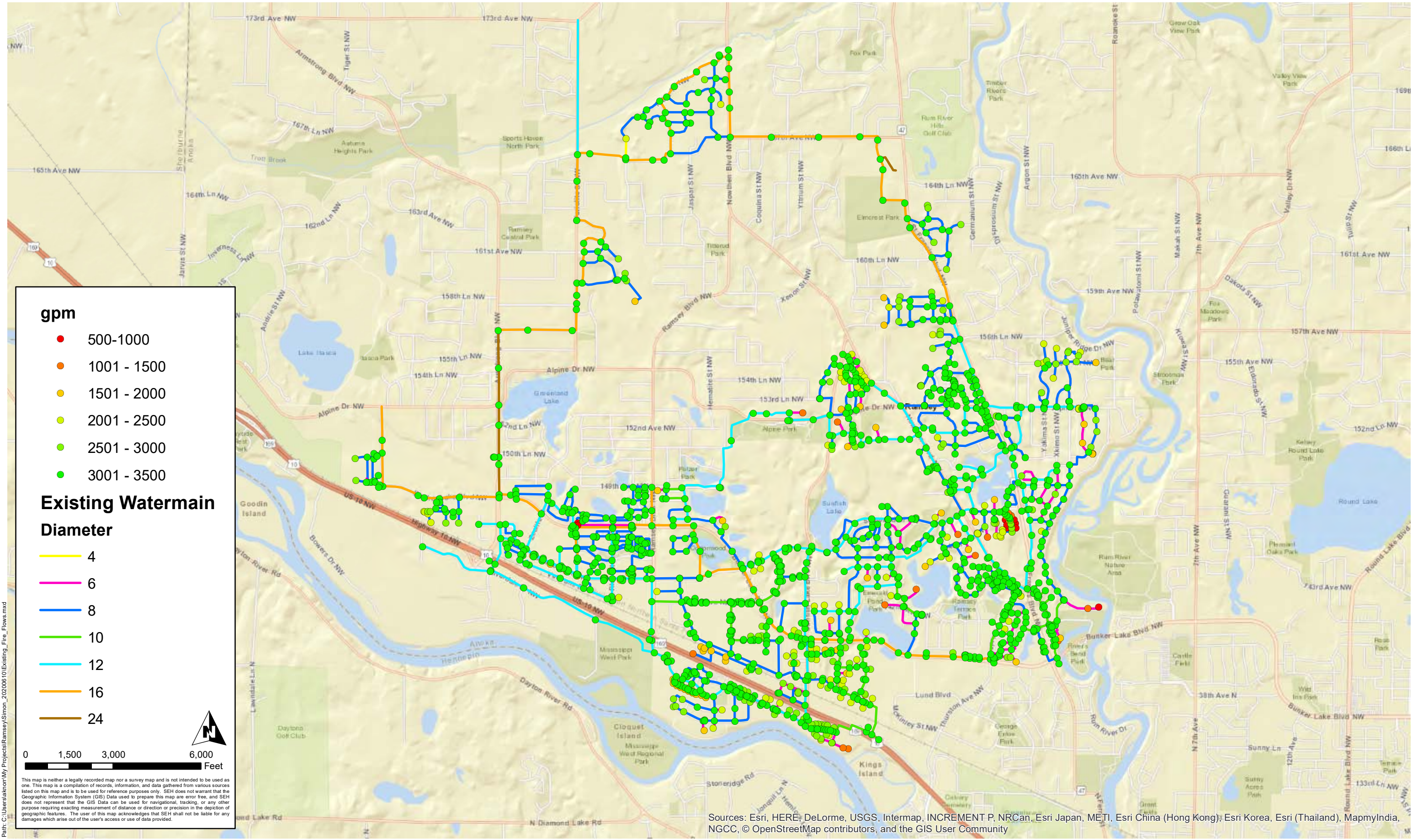

gpm

- 500-1000
- 1001 - 1500
- 1501 - 2000
- 2001 - 2500
- 2501 - 3000
- 3001 - 3500

Existing Watermain Diameter

- 4
- 6
- 8
- 10
- 12
- 16
- 24

0 1,500 3,000 6,000 Feet

This map is neither a legally recorded map nor a survey map and is not intended to be used as one. This map is a compilation of records, information, and data gathered from various sources listed on this map and is to be used for reference purposes only. SEH does not warrant that the Geographic Information System (GIS) Data used to prepare this map are error free, and SEH does not represent that the GIS Data can be used for navigational, tracking, or any other purpose requiring exacting measurement of distance or direction or precision in the depiction of geographic features. The user of this map acknowledges that SEH shall not be liable for any damages which arise out of the user's access or use of data provided.

Sources: Esri, HERE, DeLorme, USGS, Intermap, INCREMENT P, NRCan, Esri Japan, METI, Esri China (Hong Kong), Esri Korea, Esri (Thailand), MapmyIndia, NGCC, © OpenStreetMap contributors, and the GIS User Community

FIGURE 9

Existing System with Treatment Plant ADD 24-Hour Simulation High Service Pump and Tower Operation

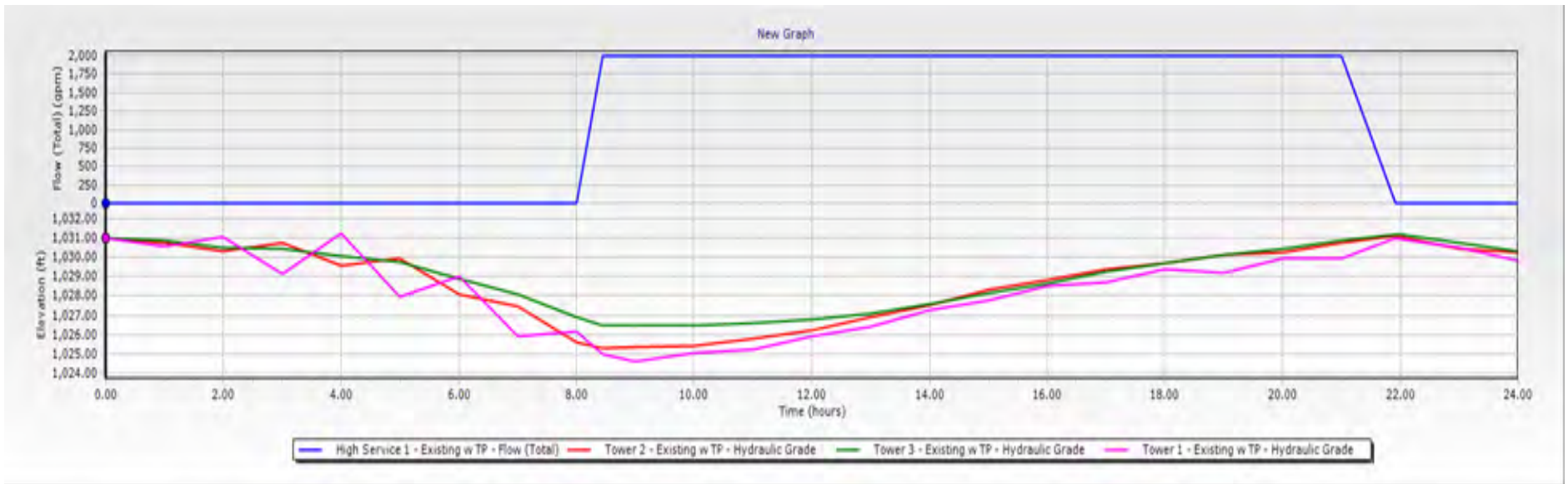
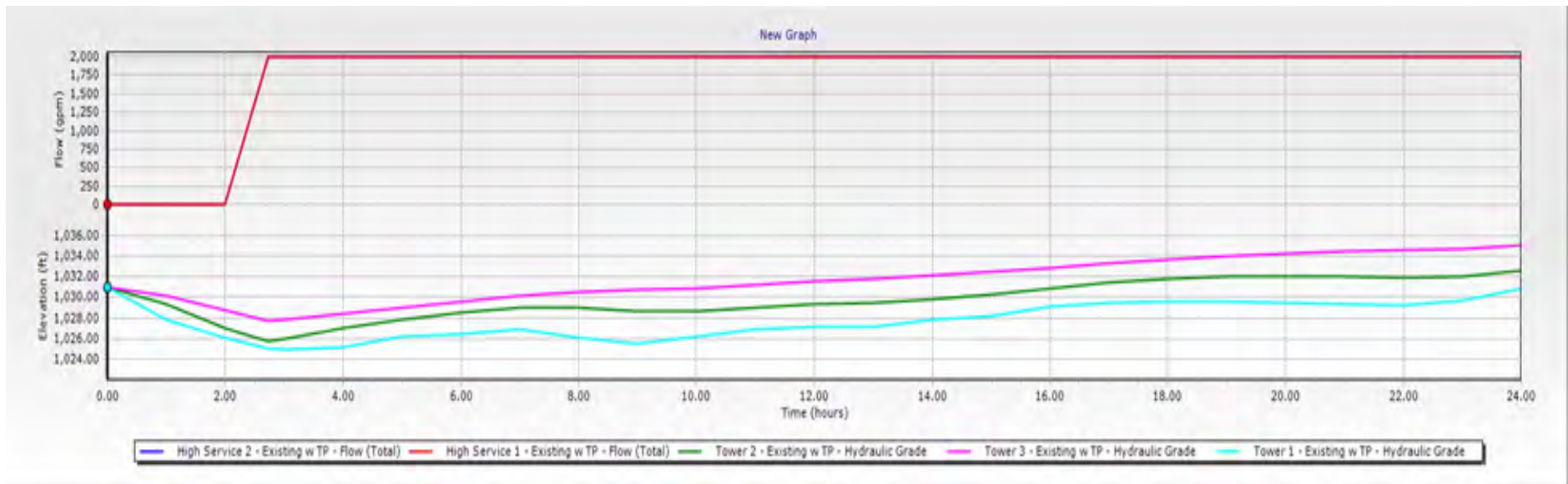
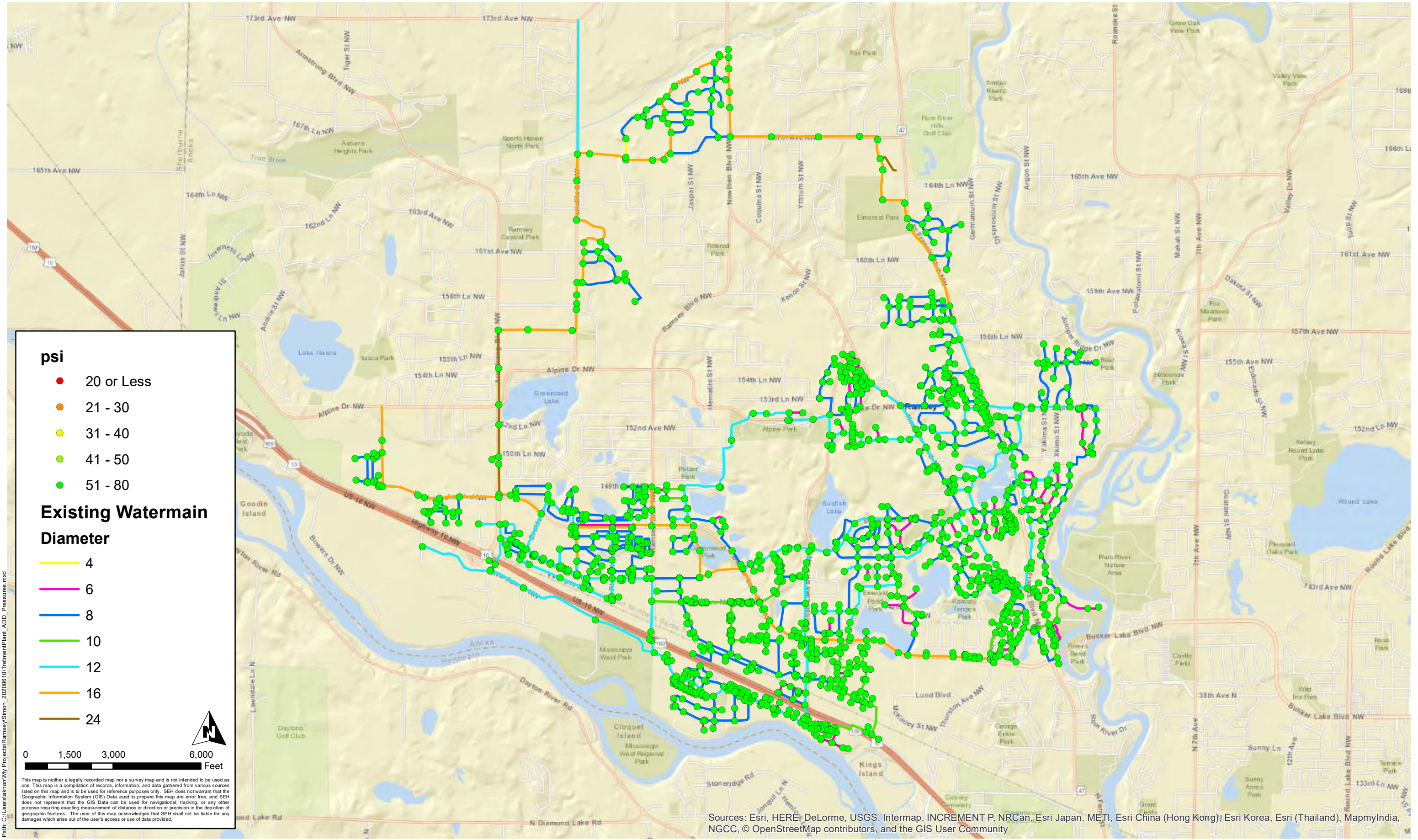

FIGURE 10

Existing System with Treatment Plan MDD 24-Hour Simulation High Service Pump and Tower Operation





TREATMENT PLANT WITH EXISTING ADD 24 HOUR EPS MINIMUM PRESSURES
 Ramsey, Minnesota

FIGURE 11
 Minimum Pressures

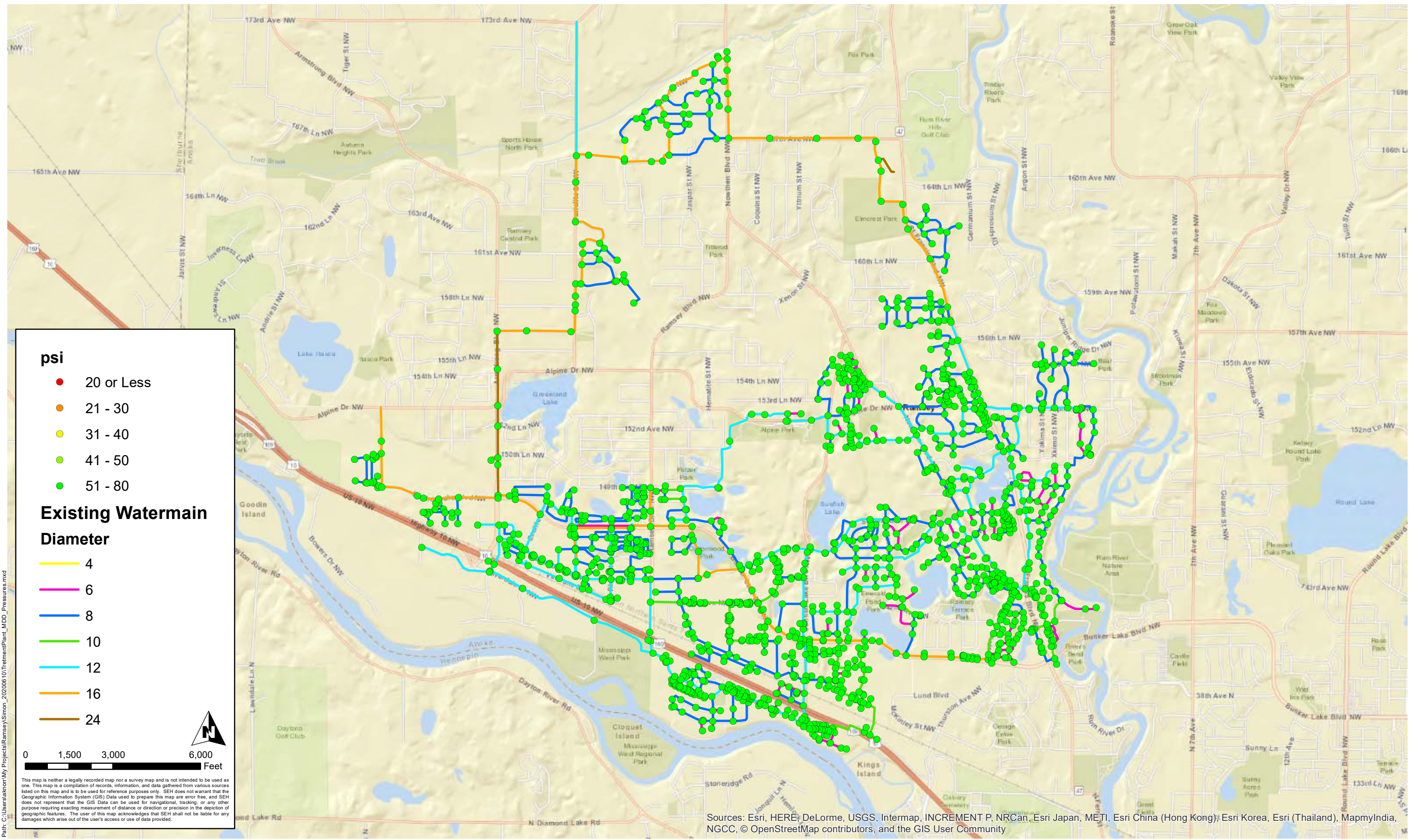

TREATMENT PLANT WITH EXISTING MDD 24 HOUR EPS MINIMUM PRESSURES
 Ramsey, Minnesota

FIGURE 12
 Minimum Pressures

FIGURE 13

2040 System ADD 24-Hour Simulation High Service Pump and Tower Operation

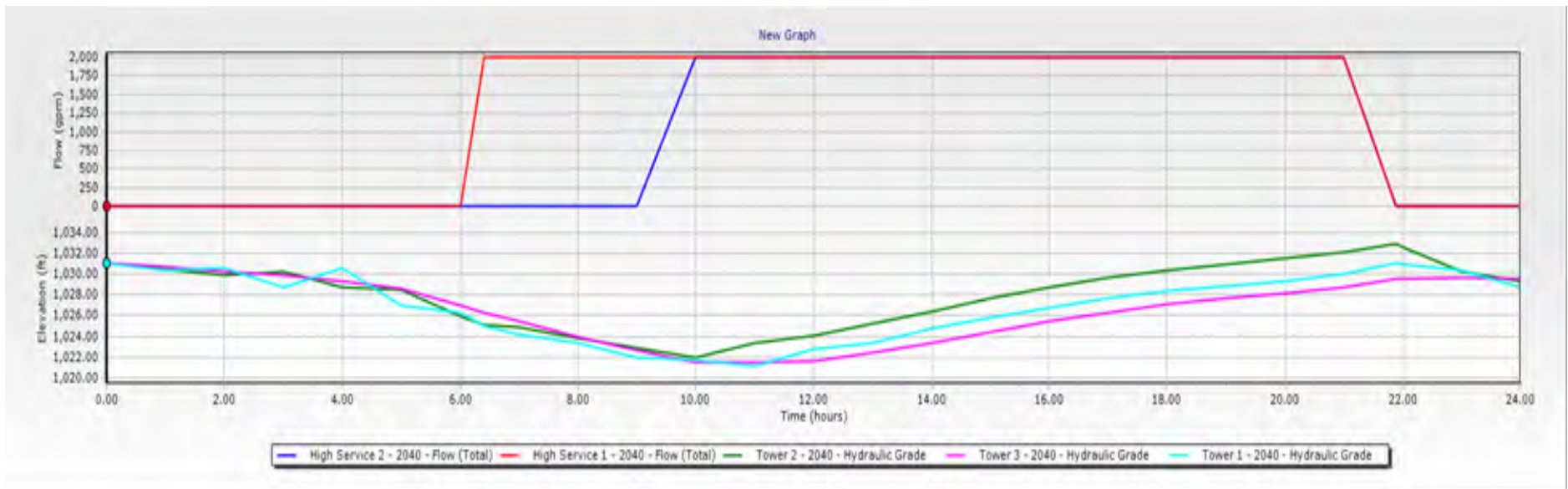
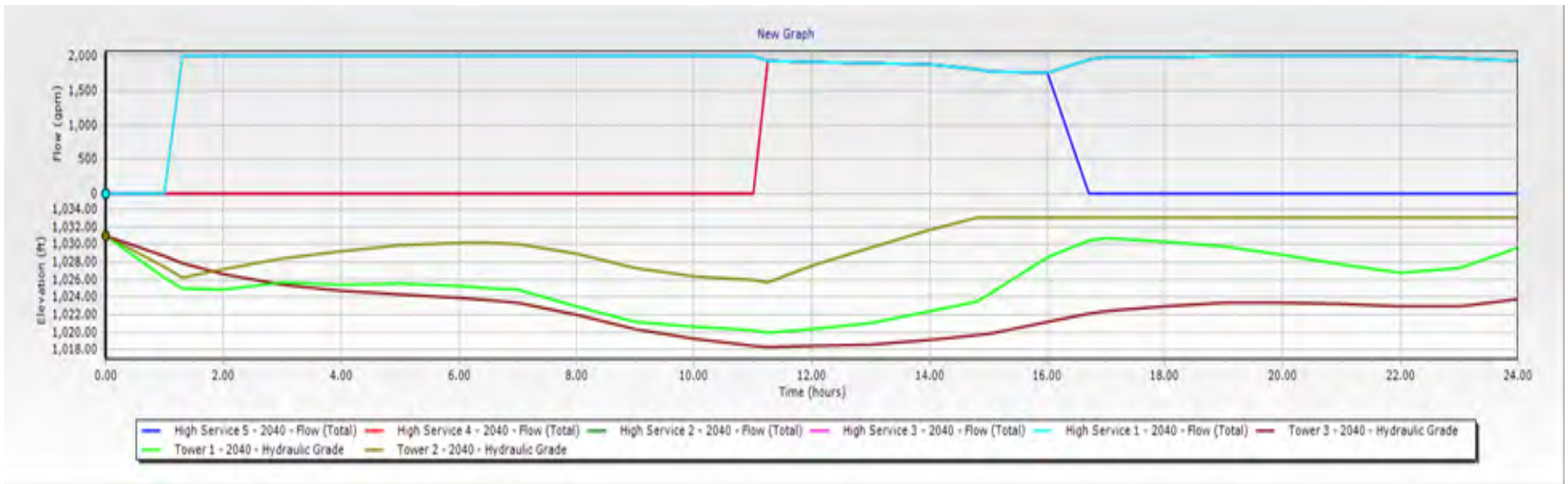
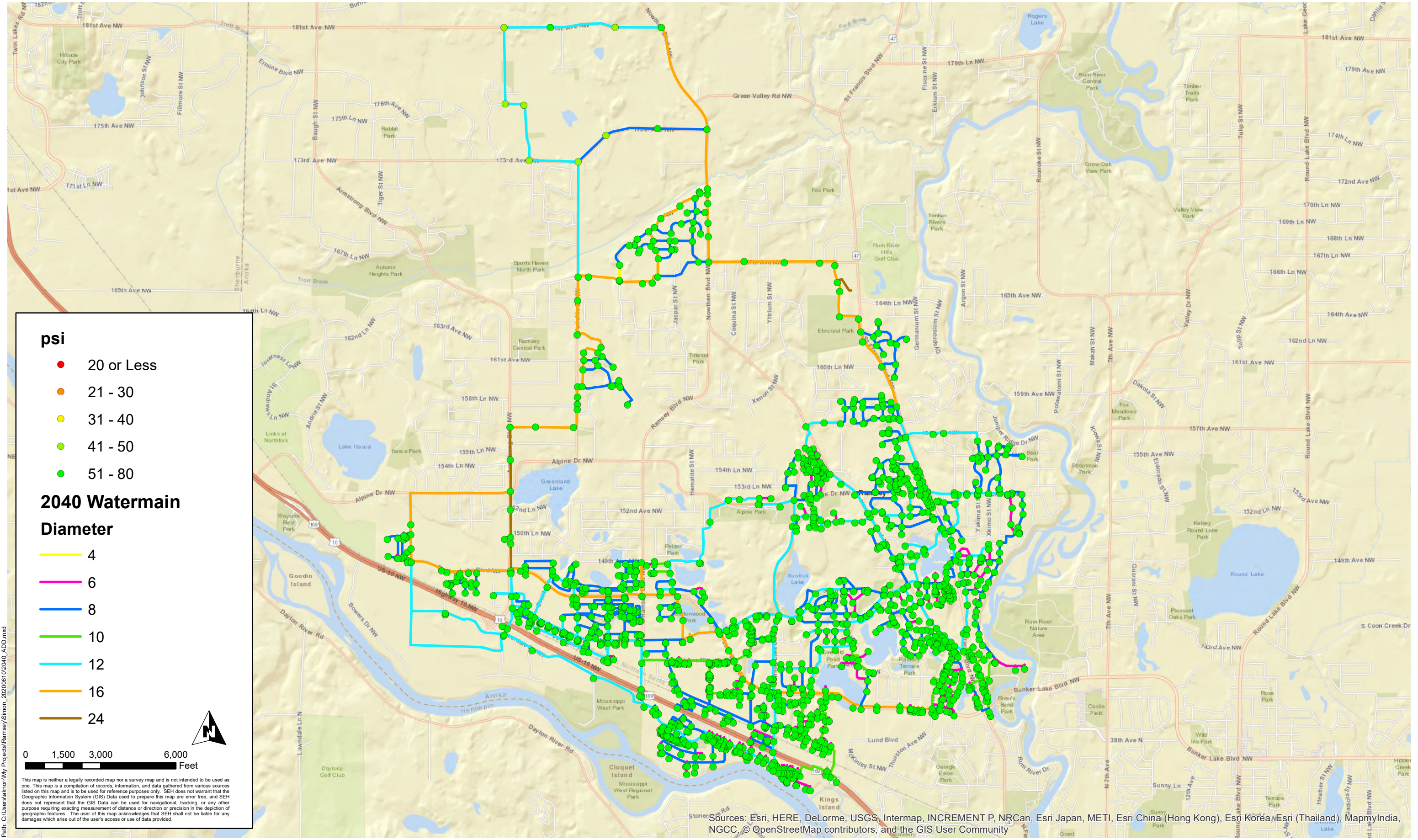

FIGURE 14

2040 System MDD 24-Hour Simulation High Service Pump and Tower Operation





Path: C:\Users\akrom\My Projects\Ramsey\Simon_20200610\2040_ADD.mxd

2040 ADD 24 HOUR EPS MINIMUM PRESSURES
 Ramsey, Minnesota

FIGURE 15
 Minimum Pressures

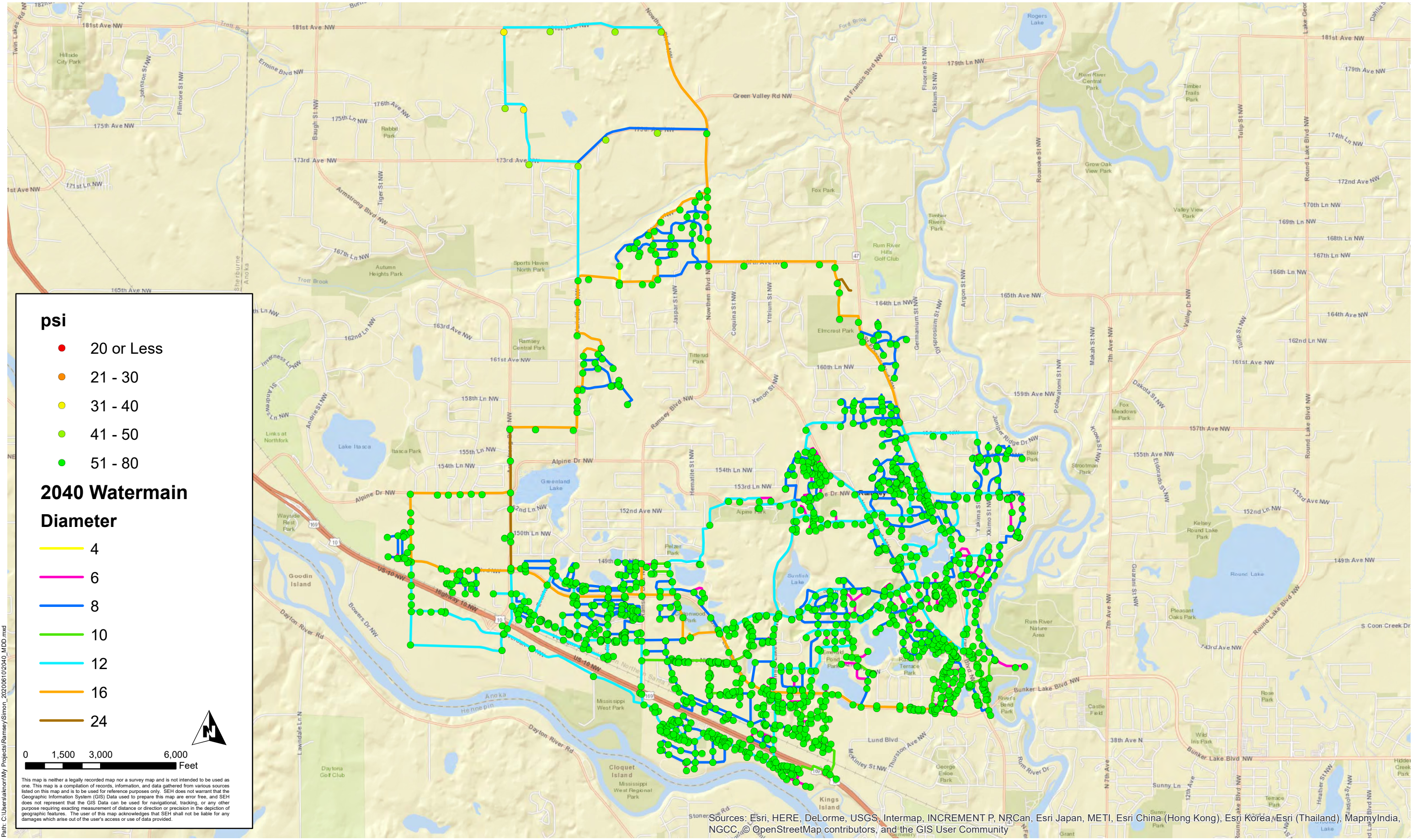

Path: C:\Users\akrom\My Projects\Ramsey\Simon_20200610\2040_MDD.mxd

2040 MDD 24 HOUR EPS MINIMUM PRESSURES
 Ramsey, Minnesota

FIGURE 16
 Minimum Pressures

Appendix C

CCL

CCL 4

Contaminant	Contaminant Type
Adenovirus	Virus
Caliciviruses	Virus (includes Norovirus)
Campylobacter jejuni	Bacteria
Enterovirus	Viruses including polioviruses, coxsackieviruses and echoviruses
Escherichia coli (0157)	Bacteria
Helicobacter pylori	Bacteria
Hepatitis A virus	Virus
Legionella pneumophila	Bacteria
Mycobacterium avium	Bacteria
Naegleria fowleri	Protozoan
Salmonella enterica	Bacteria
Shigella sonnei	Bacteria
1,1-Dichloroethane	It is an industrial solvent and an intermediate in the synthesis of other compounds.
1,1,1,2-Tetrachloroethane	It is an industrial solvent and used in the synthesis of other chlorinated compounds.
1,2,3-Trichloropropane	It is an industrial solvent, cleaning and degreasing agent as well as an intermediate in the synthesis of the other
1,3-Butadiene	It is used in the production of rubber and plastics.
1,4-Dioxane	It is used as a solvent for cellulose formulations, resins, oils, waxes and other organic substances. It is also used in wood pulping, textile processing, degreasing, in lacquers, paints, varnishes, and stains; and in paint and varnish removers.
17alpha-estradiol	It is an estrogenic hormone found in some pharmaceuticals.
1-Butanol	It is a solvent and used in production of other chemicals compounds. It is present in a number of commercial products such as perfumes.
2-Methoxyethanol	It is used in a number of consumer products, such as synthetic cosmetics, perfumes, fragrances, hair preparations, and skin lotions.
2-Propen-1-ol	It is used in the production of other chemicals.
3-Hydroxycarbofuran	It is a pesticide degradate, the parent, carbofuran, is used as an insecticide.
4,4'-Methylenedianiline	It is used in the production of polyurethanes foams, glues, rubber and spandex fiber.
Acephate	It is an insecticide.
Acetaldehyde	It is a disinfection byproduct from ozonation; it is used in the production of other chemicals.
Acetamide	It is used as a solvent and plasticizer.
Acetochlor	It is an herbicide for weed control on agricultural crops.
Acetochlor ethanesulfonic acid (ESA)	Acetochlor ESA is an environmental degradate of acetochlor.
Acetochlor oxanilic acid (OA)	Acetochlor OA is an environmental degradate of acetochlor.

Acrolein	It is used as an aquatic herbicide, rodenticide and industrial chemical.
Alachlor ethanesulfonic acid (ESA)	Alachlor ESA is an environmental degradate of the pesticide alachlor (an herbicide for weed control on agricultural crops).
Alachlor oxanilic acid (OA)	Alachlor OA is an environmental degradate of alachlor.
alpha-Hexachlorocyclohexane	It is a component of benzene hexachloride (BHC) and was formerly used as an insecticide.
Aniline	It is used as an industrial chemical, as a solvent, in the synthesis of explosives, rubber products and in isocyanates.
Bensulide	It is an herbicide.
Benzyl chloride	It is used in the production of other substances, such as plastics, dyes, lubricants, gasoline and pharmaceuticals.
Butylated hydroxyanisole	It is used as a food additive (antioxidant).
Captan	It is a fungicide.
Chlorate	Chlorate compounds are used in agriculture as defoliants or desiccants and may occur in drinking water because of use of disinfectants such as chlorine dioxide and hypochlorites.
Chloromethane (Methyl chloride)	It is used as a foaming agent and in the production of other substances.
Clethodim	It is an herbicide.
Cobalt	It is a naturally-occurring element and was formerly used as cobaltous chloride in medicines and as a germicide. It is a part of the vitamin B12 molecule
Cumene hydroperoxide	It is used as a catalyst is used in the production of other substances.
Cyanotoxins	Toxins naturally produced and released by cyanobacteria ("blue-green algae"). The group of cyanotoxins includes, but is not limited to: anatoxin-a, cylindrospermopsin, microcystins, and saxitoxin.
Dicrotophos	It is an insecticide.
Dimethipin	It is an herbicide and plant growth regulator.
Diuron	It is an herbicide.
Equilenin	It is an estrogenic hormone used in hormone replacement therapy.
Equilin	It is an estrogenic hormone and is used in hormone replacement therapy.
Erythromycin	It is used an antibiotic.
Estradiol (17-beta estradiol)	It is an isomer of estradiol found in some pharmaceuticals.
Estriol	It is a weak estrogenic hormone used in veterinary pharmaceuticals.
Estrone	It is a precursor of estradiol used in veterinary and human pharmaceuticals.
Ethinyl estradiol (17-alpha ethynyl estradiol)	It is an estrogenic hormone and is used in veterinary and human oral contraceptives.
Ethoprop	It is an insecticide.
Ethylene glycol	It is used as antifreeze, in textile manufacturing and is a cancelled pesticide.

Ethylene oxide	It is a fungicidal and insecticidal fumigant.
Ethylene thiourea	It is used in the production of other substances, such as for vulcanizing polychloroprene (neoprene) and polyacrylate rubbers and is a metabolite of some fungicides.
Formaldehyde	It is an ozonation disinfection byproduct, can occur naturally and has been used as a fungicide.
Germanium	It is a naturally-occurring element and is commonly found as germanium dioxide in phosphors, transistors and diodes, and in electroplating. In some cases it has been sold as a dietary supplement.
HCFC-22	It is used as a refrigerant, as a low-temperature solvent, and in fluorocarbon resins, especially in tetrafluoroethylene polymers.
Halon 1011 (bromochloromethane)	It is used as a fire-extinguishing fluid and to suppress explosions, as well as a solvent in the manufacturing of some pesticides. May also occur as a disinfection by-product in drinking water.
Hexane	It is a component of gasoline and used as a solvent.
Hydrazine	It is used as an ingredient in the production of other substances, such as rocket propellants. It is also used in the production of plastics.
Manganese	It is a naturally-occurring element used in a variety of applications including use in steel production to improve hardness, stiffness and strength. It is an essential nutrient found in vitamin/mineral supplement and in fortified foods.
Mestranol	It is a precursor to ethinylestradiol used in veterinary and human pharmaceuticals.
Methamidophos	It is an insecticide.
Methanol	It is used as an industrial solvent, a gasoline additive and as an anti-freeze ingredient.
Methyl bromide (bromomethane)	It has been used as a fumigant and fungicide.
Methyl tert-butyl ether (MTBE)	It is used as an octane booster in gasoline, in the manufacturing of isobutene and as an extraction solvent.
Metolachlor	It is an herbicide for weed control on agricultural crops.
Metolachlor ethanesulfonic acid (ESA)	Metolachlor ESA is an environmental degradate of metolachlor.
Metolachlor oxanilic acid (OA)	Metolachlor OA is an environmental degradate of
Molybdenum	It is a naturally-occurring element and is commonly found as molybdenum trioxide. It is used as a steel alloy. It is an essential dietary nutrient found in foods and nutritional supplements.
Nitrobenzene	It is used in the production of aniline, and also as a solvent in the manufacturing of paints, shoe polishes, floor polishes, metal polishes, explosives, dyes, pesticides and drugs (such as acetaminophen).,

Nitroglycerin	It is used in the production of explosives, and in rocket propellants. It is also a pharmaceutical for the treatment of angina.
N-Methyl-2-pyrrolidone	It is a solvent in the chemical industry, and is used in the formulation of pharmaceuticals for oral and dermal delivery.
N-nitrosodiethylamine (NDEA)	It is a nitrosamine used as an additive in gasoline and in lubricants, as an antioxidant and as a stabilizer in plastics. It is formed in cured foods and during high temperature cooking of meats and fish, and may be a disinfection byproduct.
N-nitrosodimethylamine (NDMA)	It was formerly used in the production of rocket fuels, antioxidants and softeners for copolymers. It is formed in cured foods and during high temperature cooking. It may be a leachate from rubber gaskets and fittings and may form as a disinfection byproduct.
N-nitroso-di-n-propylamine (NDPA)	It is formed in cured foods and during high temperature cooking of meats and fish and may be a disinfection byproduct. It is a contaminant in dinitrofluralin herbicides.
N-Nitrosodiphenylamine	It is used in the vulcanization of rubber and as an inhibitor of polymerization in the production of polystyrene. It may be a disinfection byproduct.
N-nitrosopyrrolidine (NPYR)	It is used in rubber production. It is formed in cured foods and during high temperature cooking of meats and fish and may be a disinfection byproduct.
Nonylphenol2	The main use of nonylphenol is in the manufacture of nonylphenol ethoxylates, which have been used in a wide range of industrial applications and consumer products including laundry detergents, cleaners, degreasers, paints and coatings and other uses. Several other CASRNs are associated with nonylphenol due to varying chemical structures including: 104-40-5, 84852-15-3, 91672-41-2, and 139-84-4.
Norethindrone (19-Norethisterone)	Norethindrone is a synthetic hormone used in oral contraceptives and for hormone replacement therapy.
n-Propylbenzene	It is a constituent of asphalt and naphtha and used in the manufacture of methyl styrene. It is a solvent for printing and dyeing of textiles.
o-Toluidine	It is used in the production of dyes, rubber, pharmaceuticals and pesticides.
Oxirane, methyl	It is an industrial chemical used in the production of other substances. It is a registered pesticide.
Oxydemeton-methyl	It is an insecticide.
Oxyfluorfen	It is an herbicide.
Perfluorooctanesulfonic acid (PFOS)	PFOS has been used to make carpets, leathers, textiles, fabrics for furniture, paper packaging, and other materials that are resistant to water, grease, or stains. It is also used in firefighting foams at airfields. Many of these uses have been phased out by its primary U.S. manufacturer; however, there are still some ongoing uses.

Perfluorooctanoic acid (PFOA)	PFOA has been used to make carpets, leathers, textiles, fabrics for furniture, paper packaging, and other materials that are resistant to water, grease, or stains. It is also used in firefighting foams at airfields. Many of these uses are being phased out by U.S. manufacturers; however, there are still some ongoing uses.
Permethrin	It is an insecticide.
Profenofos	It is an insecticide and an acaricide.
Quinoline	It is a component of coal tars and used in the production of other substances, and as a pharmaceutical (anti-malarial).
RDX (Hexahydro-1,3,5-trinitro-1,3,5-triazine)	It is an explosive.
sec-Butylbenzene	It is used as a solvent for coatings in organic synthesis, as a plasticizer and in surfactants.
Tebuconazole	It is a fungicide.
Tebufenozide	It is insecticide.
Tellurium	It is a naturally-occurring element and is commonly used as sodium tellurite in bacteriology and medicine.
Thiodicarb	It is an insecticide.
Thiophanate-methyl	It is a fungicide.
Toluene diisocyanate	It is used in the manufacturing of plastics.
Tribufos	It is an insecticide and used as a cotton defoliant.
Triethylamine	It is used in the production of other substances, as a stabilizer in herbicides and pesticides, in consumer products, in photographic chemicals and in carpet cleaners.
Triphenyltin hydroxide (TPTH)	It is a pesticide.
Urethane	It is a paint and coating ingredient (polyurethanes).
Vanadium	It is a naturally-occurring element. Vanadium pentoxide is a catalyst for the production of other substances catalyst. It is sometimes an ingredient in mineral supplements but is not classified as an essential nutrient
Vinclozolin	It is a fungicide.
Ziram	It is a fungicide.

Appendix D

Groundwater Modeling Memo

Path: S:\KO\MCES\150732\5-Final-dgms\5-Final-dgms\GIS\Maps\Geology\Review\Ramsey-Project\Figure1.mxd

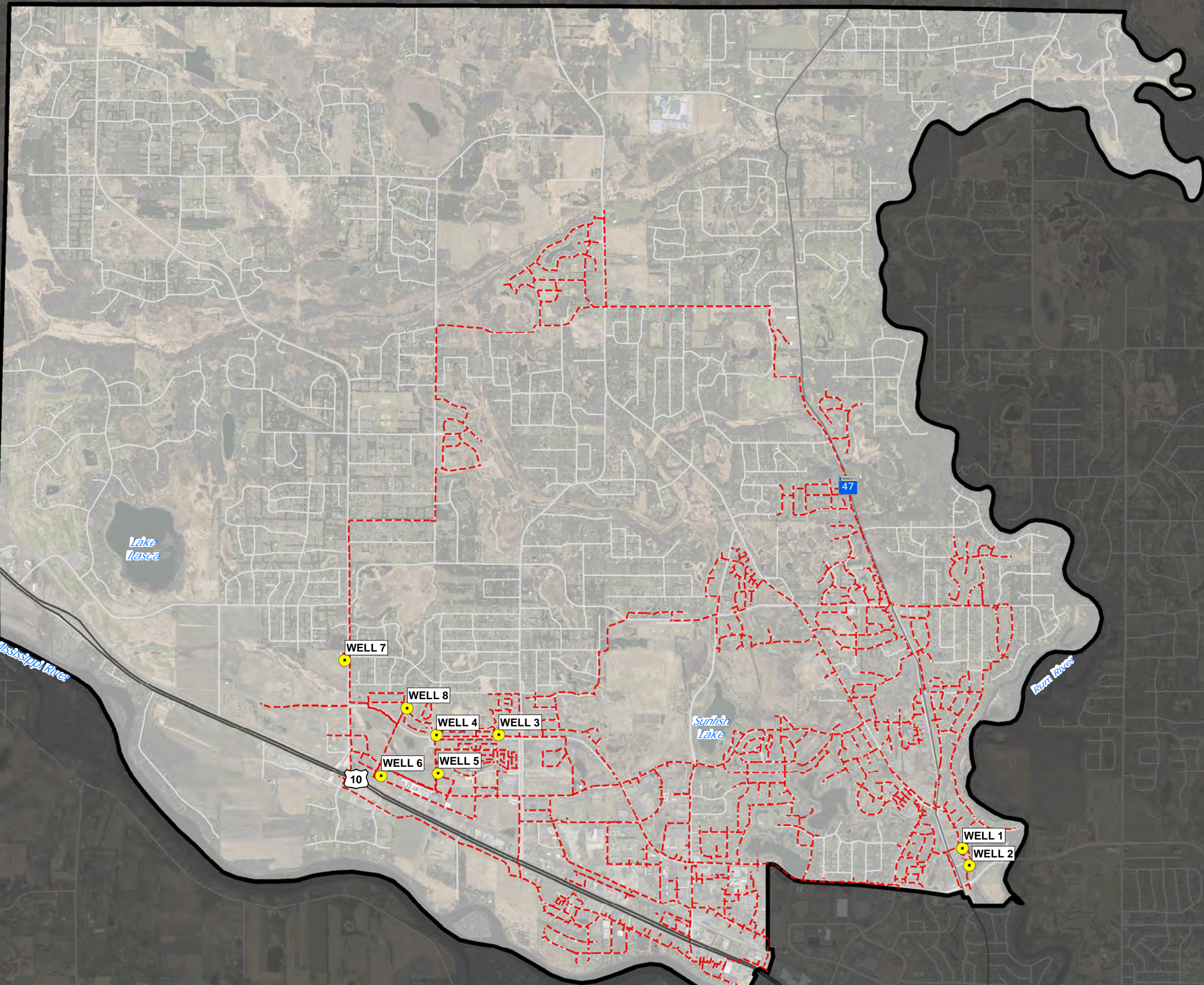

- Legend**
- Municipal Well
 - - - Municipal Watermain
 - Municipality Boundary

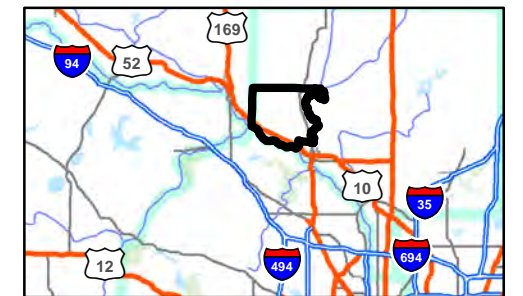
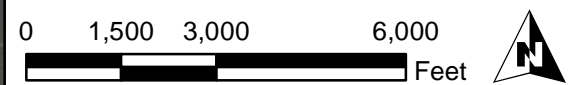

Distribution System

Source Water Analysis City of Ramsey Minnesota

This map is neither a legally recorded map nor a survey map and is not intended to be used as one. This map is a compilation of records, information, and data gathered from various sources listed on this map and is to be used for reference purposes only. SEH does not warrant that the Geographic Information System (GIS) Data used to prepare this map are error free, and SEH does not represent that the GIS Data can be used for navigational, tracking, or any other purpose requiring exacting measurement of distance or direction or precision in the depiction of geographic features. The user of this map acknowledges that SEH shall not be liable for any damages which arise out of the user's access or use of data provided.



Project: MCES 150732
Print Date: 11/7/2019
Map by: Msherrill
Projection: UTM Zone 15N
Source: ESRI, SEH Digi MndOT,
Minnesota Geologic Survey (MGS)

Figure
1

Path: S:\KO\M\CES\1507325-Final-dsgm\5-drawings\90-GIS\Maps\Geology\Review\Ramsey - Project\Figure2.mxd

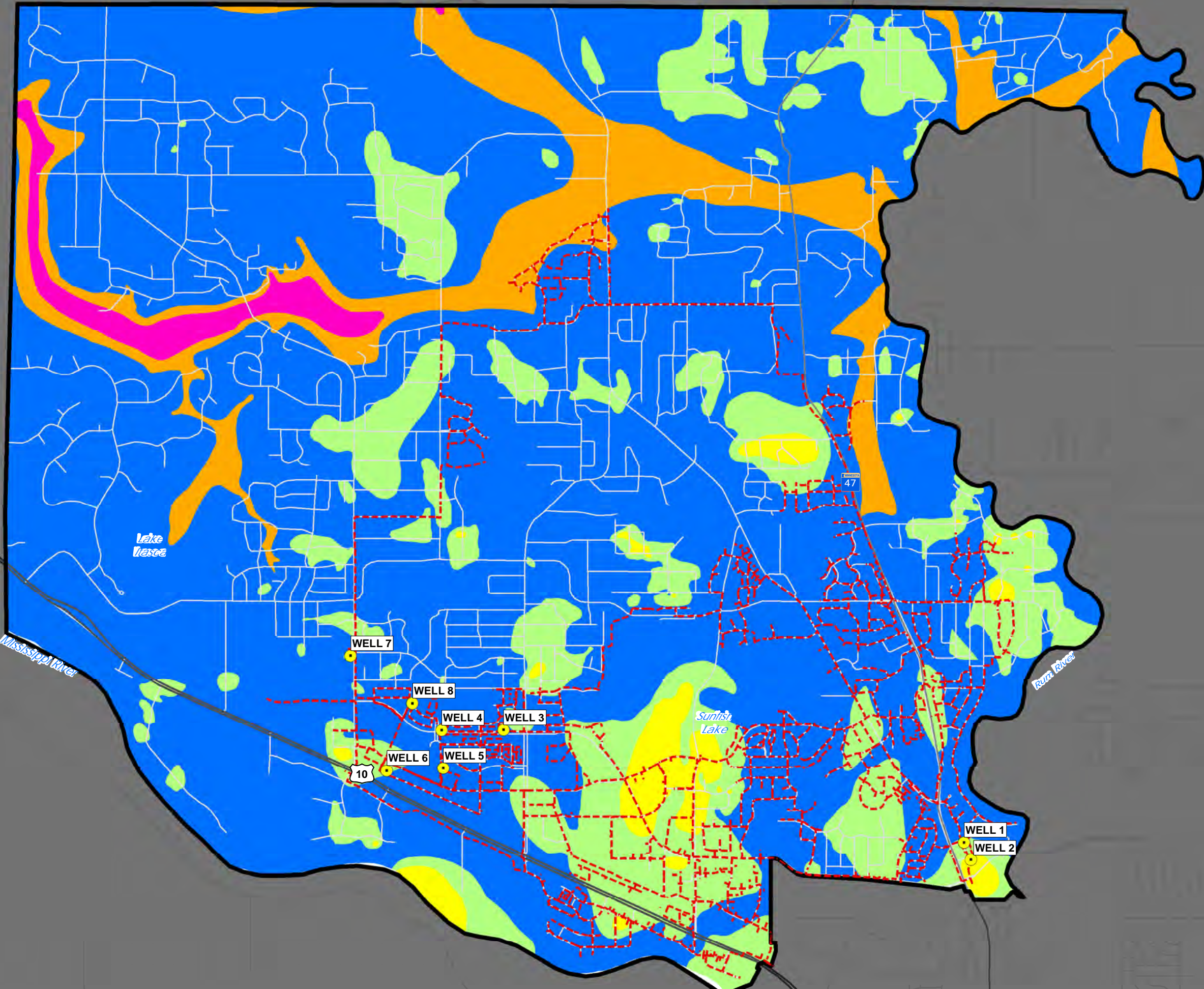

- Legend**
- Municipal Well
 - Municipal Watermain
 - Municipality Boundary
- Anoka County Bedrock Geology**
- Jordan Sandstone, Up. Camb.
 - St. Lawrence Formation, Up. Camb.
 - Tunnel City group, Up. Camb.
 - Wonewoc Sandstone, Up. Camb.
 - Eau Claire Formation, Mid. to Up. Camb.

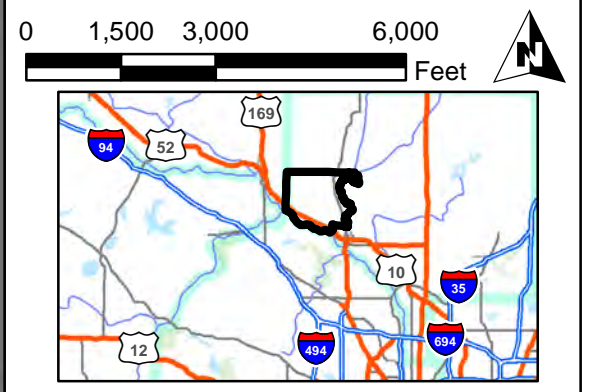

Bedrock Geology

Source Water Analysis City of Ramsey Minnesota

This map is neither a legally recorded map nor a survey map and is not intended to be used as one. This map is a compilation of records, information, and data gathered from various sources listed on this map and is to be used for reference purposes only. SEH does not warrant that the Geographic Information System (GIS) Data used to prepare this map are error free, and SEH does not represent that the GIS Data can be used for navigational, tracking, or any other purpose requiring exacting measurement of distance or direction or precision in the depiction of geographic features. The user of this map acknowledges that SEH shall not be liable for any damages which arise out of the user's access or use of data provided.

	Project: MCES 150732	<h2>Figure 2</h2>
	Print Date: 11/7/2019	
<small>Map by: Msherrill Projection: UTM Zone 15N Source: ESRI, SEH Digi MndOT, Minnesota Geologic Survey (MGS)</small>		

Path: S:\K0\MMCES\150732\5- final-dsgn\5-1-drawings\90-GIS\Maps\Geology\Review\Ramse - Project\Figure3.mxd

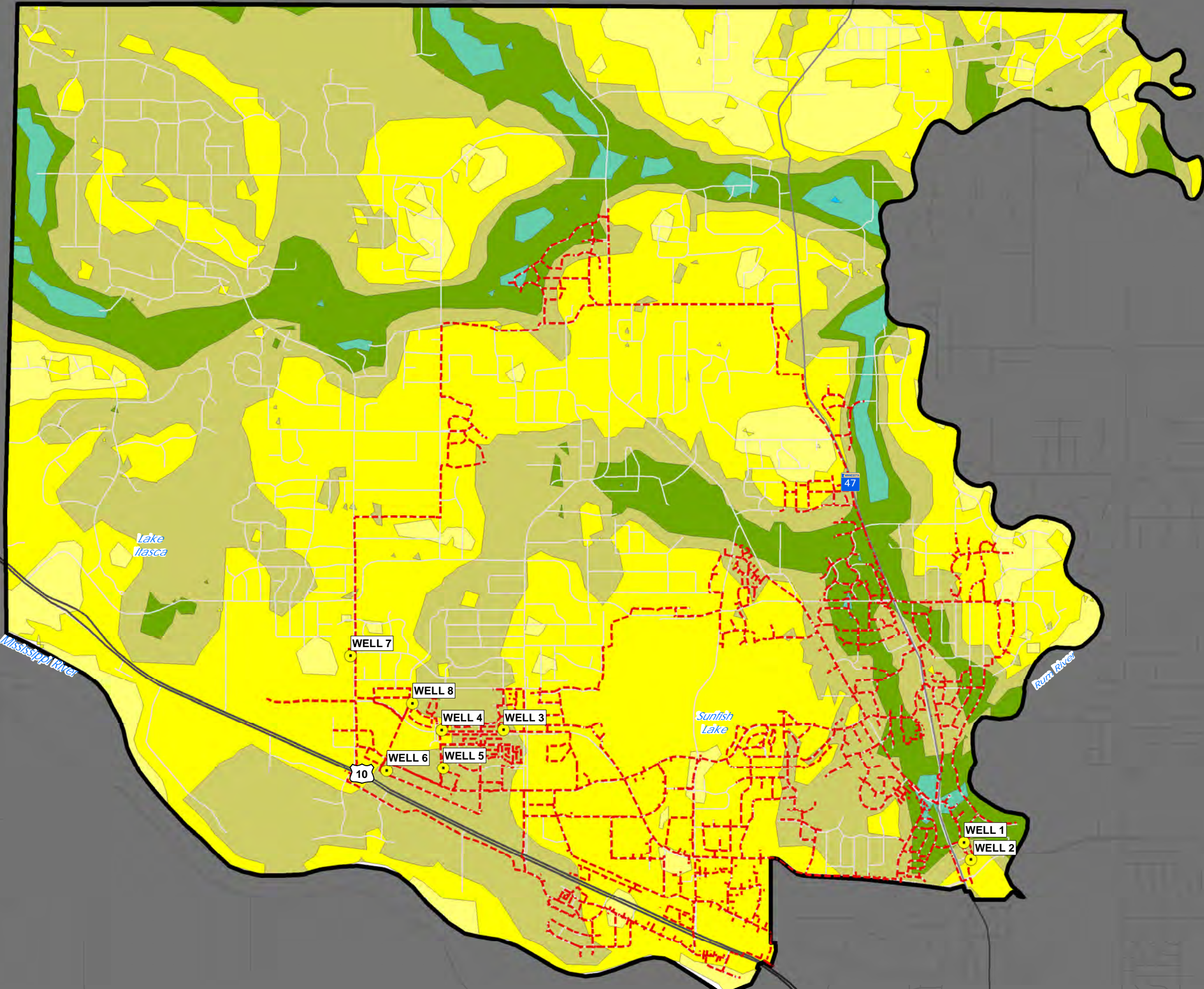

- Legend**
- Municipal Well
 - - - Municipal Watermain
 - Municipality Boundary

Anoka County Depth to Bedrock (ft.)

Depth to bedrock (ft.)

- 1-50
- 51-100
- 101-150
- 151-200
- 201-250
- 251-300
- 301-350
- 351-400
- 401-450
- 451-500

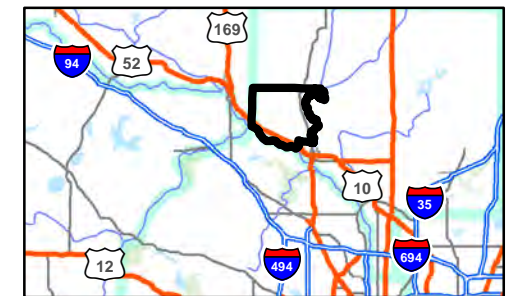
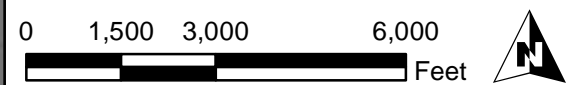

Depth to Bedrock

**Source Water Analysis
City of Ramsey
Minnesota**

This map is neither a legally recorded map nor a survey map and is not intended to be used as one. This map is a compilation of records, information, and data gathered from various sources listed on this map and is to be used for reference purposes only. SEH does not warrant that the Geographic Information System (GIS) Data used to prepare this map are error free, and SEH does not represent that the GIS Data can be used for navigational, tracking, or any other purpose requiring exacting measurement of distance or direction or precision in the depiction of geographic features. The user of this map acknowledges that SEH shall not be liable for any damages which arise out of the user's access or use of data provided.



Project: MCES 150732
 Print Date: 11/7/2019
 Map by: Msherrill
 Projection: UTM Zone 15N
 Source: ESRI, SEH Digi MNDOT,
 Minnesota Geologic Survey (MGS)

**Figure
3**

Path: S:\KO\M\CES\1507325-Final-dgms\5-drawings\90-GIS\Maps\Geology\Review\Ramsey-Project\Figure4.mxd

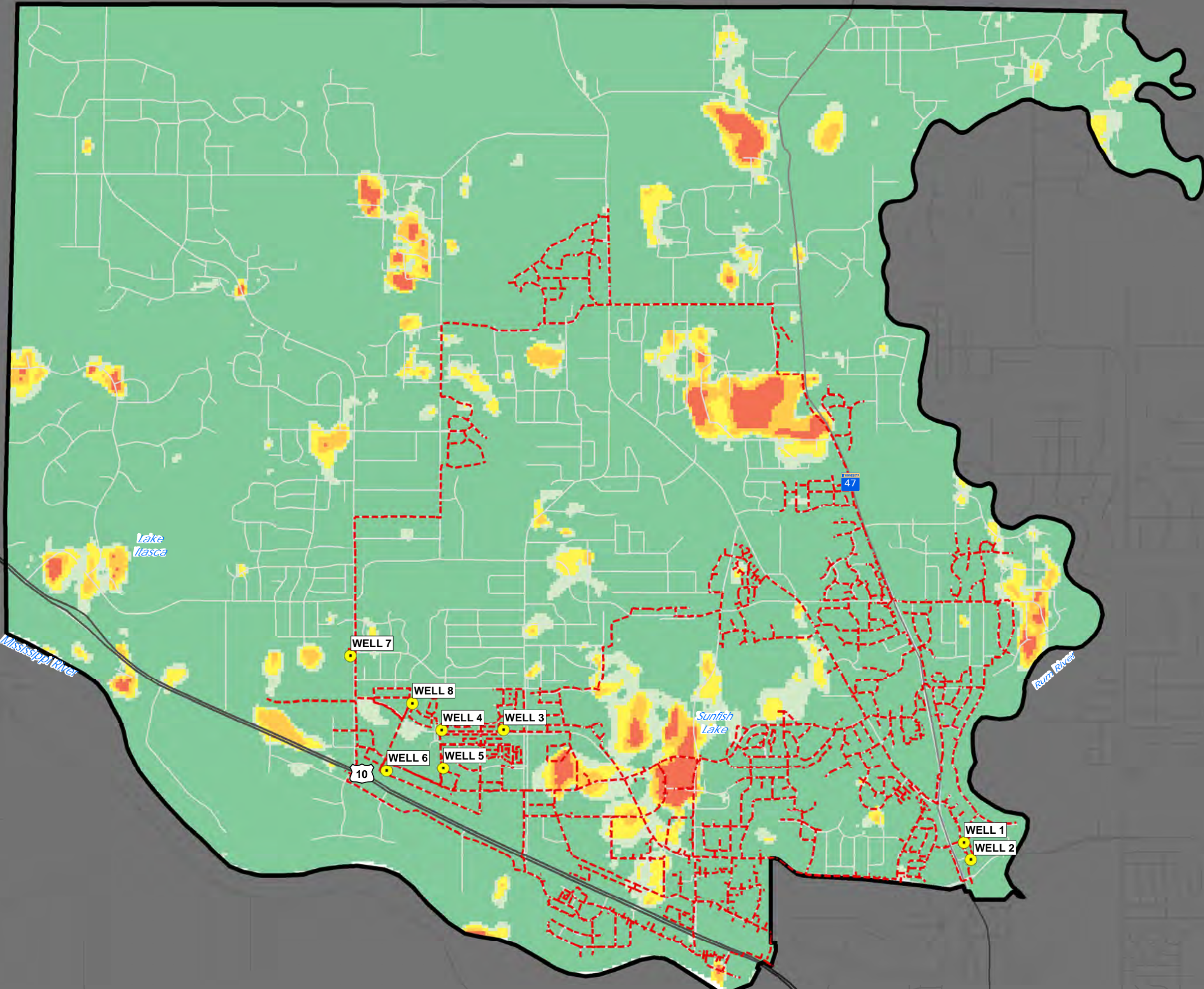

- Legend**
- Municipal Well
 - Municipal Watermain
 - Municipality Boundary

- Pollution Sensitivity (Top of Bedrock)**
- Very High
 - High
 - Moderate
 - Low
 - Very Low

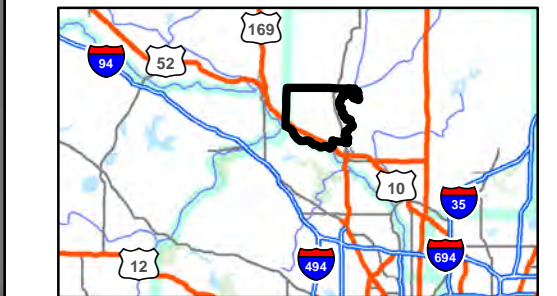
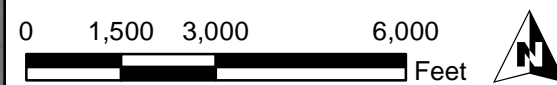
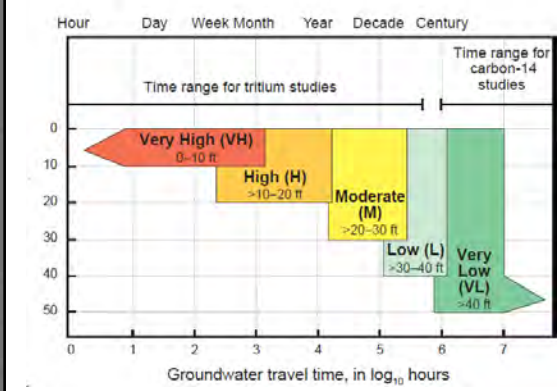

Pollution Sensitivity

Source Water Analysis
City of Ramsey
Minnesota

This map is neither a legally recorded map nor a survey map and is not intended to be used as one. This map is a compilation of records, information, and data gathered from various sources listed on this map and is to be used for reference purposes only. SEH does not warrant that the Geographic Information System (GIS) Data used to prepare this map are error free, and SEH does not represent that the GIS Data can be used for navigational, tracking, or any other purpose requiring exacting measurement of distance or direction or precision in the depiction of geographic features. The user of this map acknowledges that SEH shall not be liable for any damages which arise out of the user's access or use of data provided.

	Project: MCES 150732	<h1>Figure</h1> <h2>4</h2>
	Print Date: 11/7/2019	
<small>Map by: Msherrill Projection: UTM Zone 15N Source: ESRI, SEH Digi MndOT, Minnesota Geologic Survey (MGS)</small>		

Path: S:\KO\MCES\150732\5-Final-dgms\5-Final-dgms\GIS\Maps\Geology\Review\Ramsey-Project\Figure5.mxd

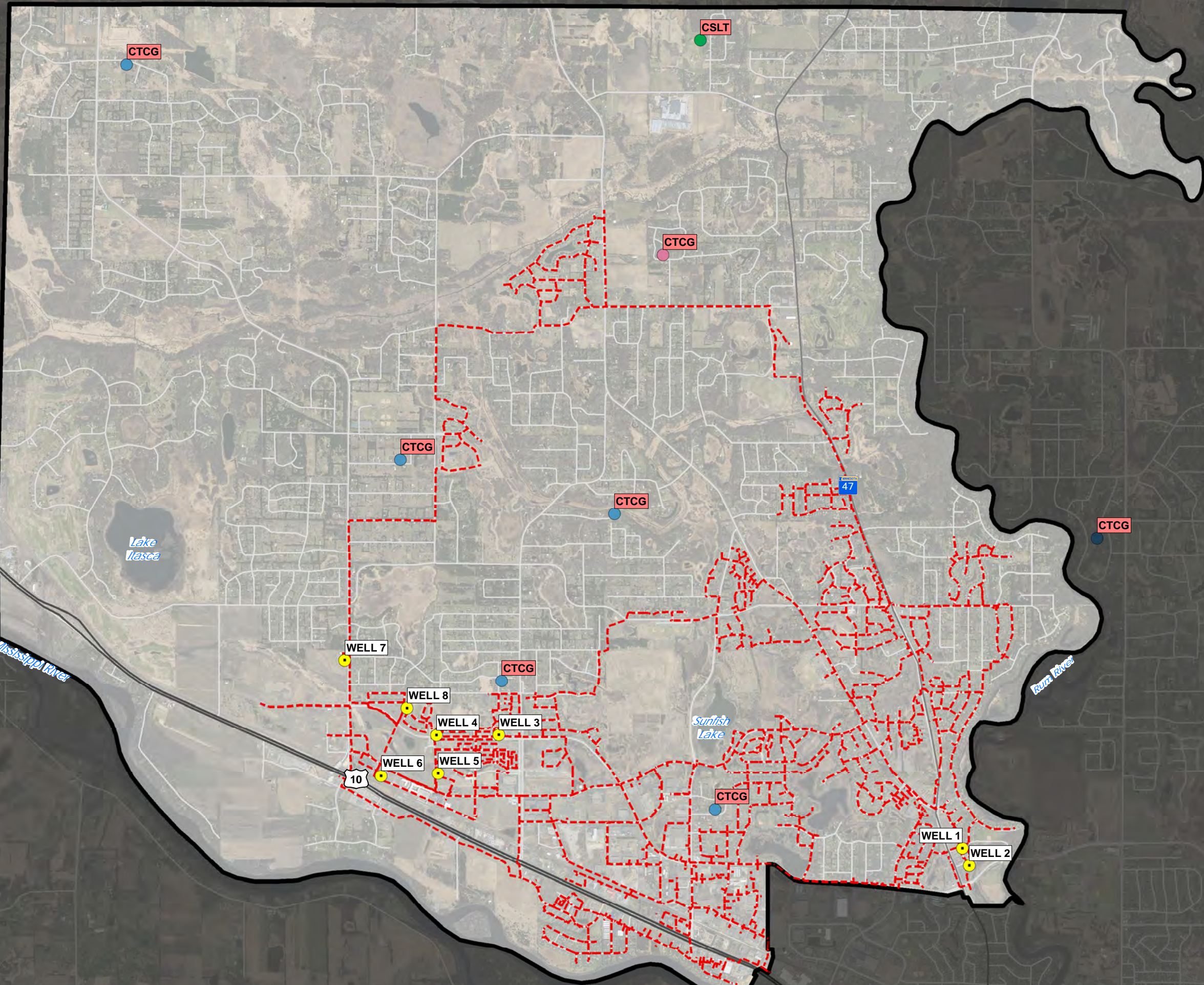

Legend

- Municipal Well
- - - Municipal Watermain
- Municipality Boundary

Tritium

Bedrock Water Age Dating Method

- recent
- mixed
- vintage
- not sampled

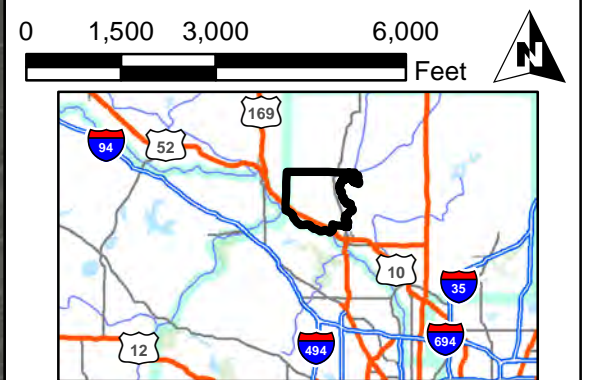

Tritium Data

Source Water Analysis
City of Ramsey
Minnesota

This map is neither a legally recorded map nor a survey map and is not intended to be used as one. This map is a compilation of records, information, and data gathered from various sources listed on this map and is to be used for reference purposes only. SEH does not warrant that the Geographic Information System (GIS) Data used to prepare this map are error free, and SEH does not represent that the GIS Data can be used for navigational, tracking, or any other purpose requiring exacting measurement of distance or direction or precision in the depiction of geographic features. The user of this map acknowledges that SEH shall not be liable for any damages which arise out of the user's access or use of data provided.

	Project: MCES 150732 Print Date: 11/7/2019	Figure 5
	Map by: Msherrill Projection: UTM Zone 15N Source: ESRI, SEH Digi MndOT, Minnesota Geologic Survey (MGS)	

Path: S:\KO\MMCES\160732\5-Final-dsgm\5-Final-dsgm\5-GIS\Maps\Geology\Review\Ramsey - Project\Figure7.mxd

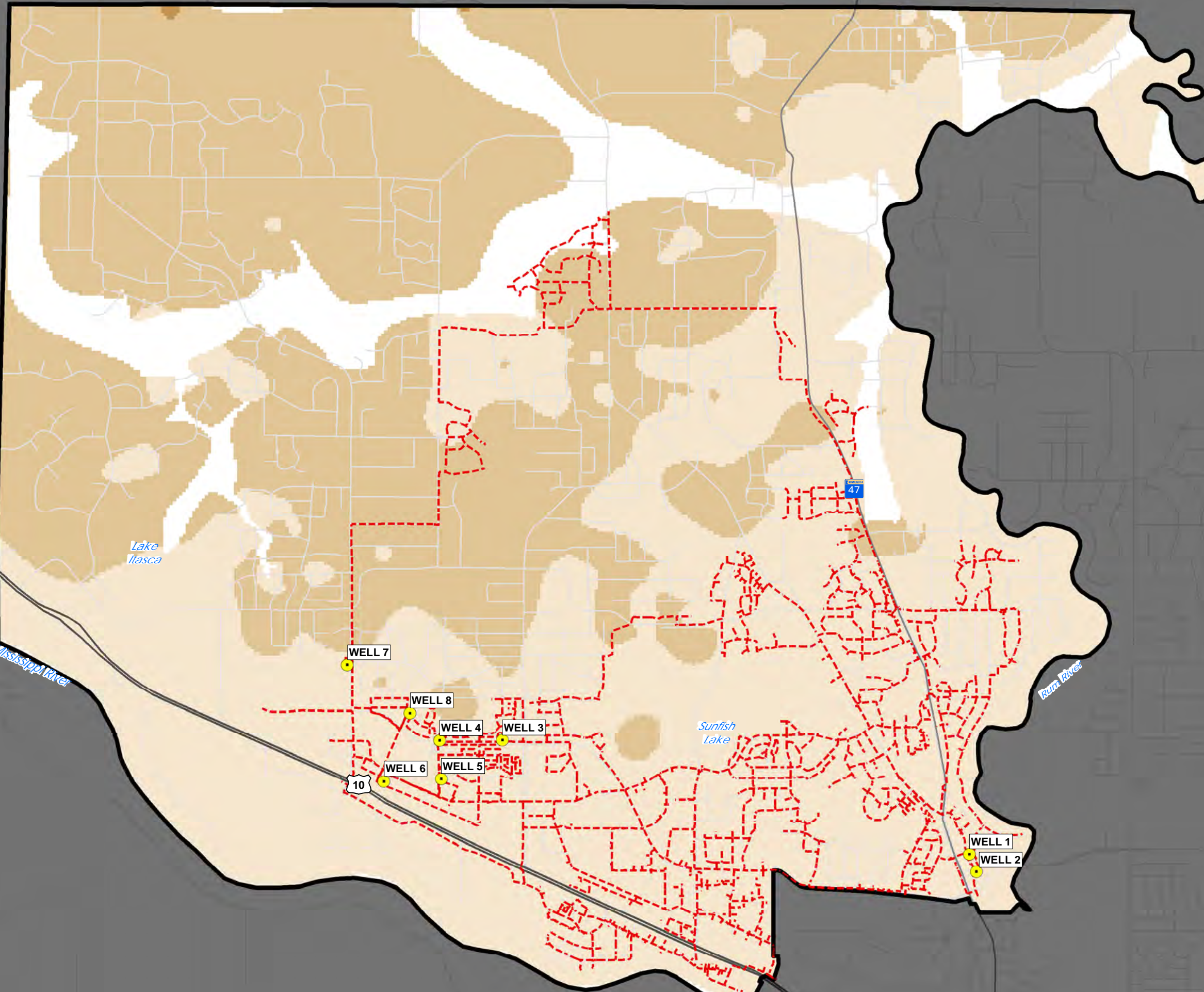

Legend

- Municipal Well
- - - Municipal Watermain
- Municipality Boundary

Potentiometric surface elevation

ELEVATION

- >820 to 860
- >860 to 900
- >900 to 940

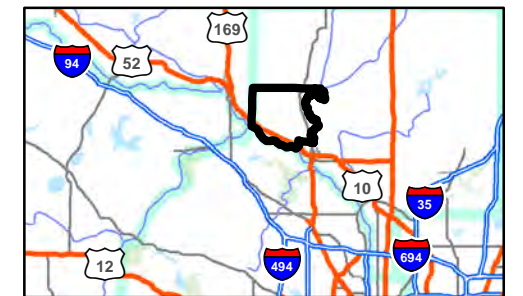
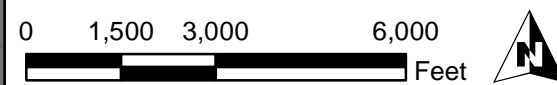

Tunnel City Potentiometric Water Elevation

Source Water Analysis
City of Ramsey
Minnesota

This map is neither a legally recorded map nor a survey map and is not intended to be used as one. This map is a compilation of records, information, and data gathered from various sources listed on this map and is to be used for reference purposes only. SEH does not warrant that the Geographic Information System (GIS) Data used to prepare this map are error free, and SEH does not represent that the GIS Data can be used for navigational, tracking, or any other purpose requiring exacting measurement of distance or direction or precision in the depiction of geographic features. The user of this map acknowledges that SEH shall not be liable for any damages which arise out of the user's access or use of data provided.



Project: MCES 150732
Print Date: 11/7/2019
Map by: Msherrill
Projection: UTM Zone 15N
Source: ESRI, SEH Digi MndOT, Minnesota Geologic Survey (MGS)

Figure
7

Path: S:\K0\MMCES\150732\5- final-dsgn\5-1-drawings\90-GIS\Maps\Geology\Review\Ramsey - Project\Figure8.mxd

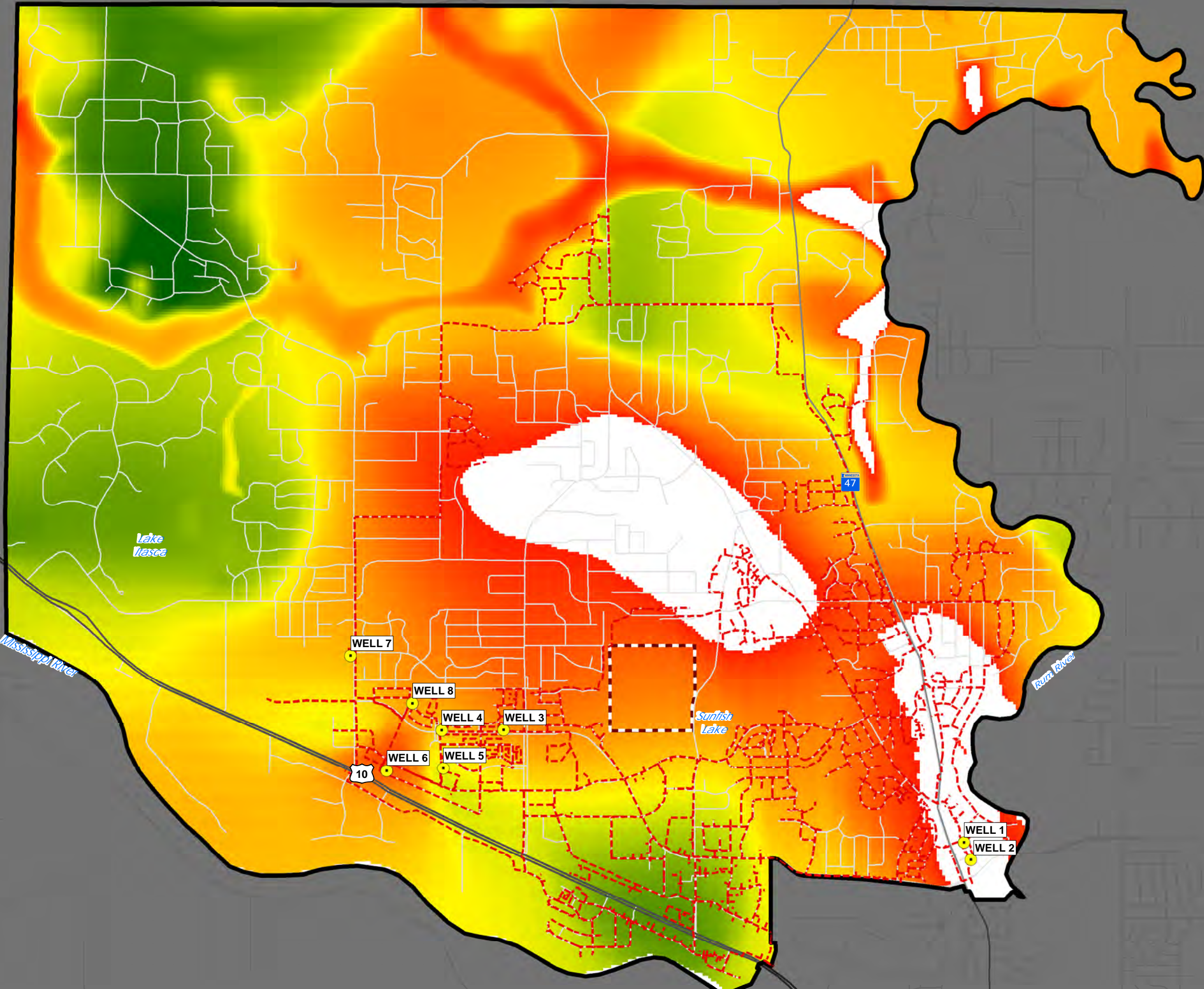

Legend

- Municipal Well
- Municipal Watermain
- Municipality Boundary
- Landfill Boundary

Wonewoc Thickness (feet)

Value

- 133.674
- 120.307
- 106.939
- 93.5718
- 80.2044
- 66.837
- 53.4696
- 40.1022
- 26.7348
- 13.3675
- 6.10352e-05

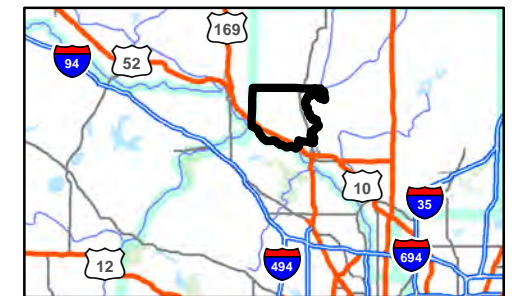

Wonewoc Thickness

**Source Water Analysis
City of Ramsey
Minnesota**

This map is neither a legally recorded map nor a survey map and is not intended to be used as one. This map is a compilation of records, information, and data gathered from various sources listed on this map and is to be used for reference purposes only. SEH does not warrant that the Geographic Information System (GIS) Data used to prepare this map are error free, and SEH does not represent that the GIS Data can be used for navigational, tracking, or any other purpose requiring exacting measurement of distance or direction or precision in the depiction of geographic features. The user of this map acknowledges that SEH shall not be liable for any damages which arise out of the user's access or use of data provided.







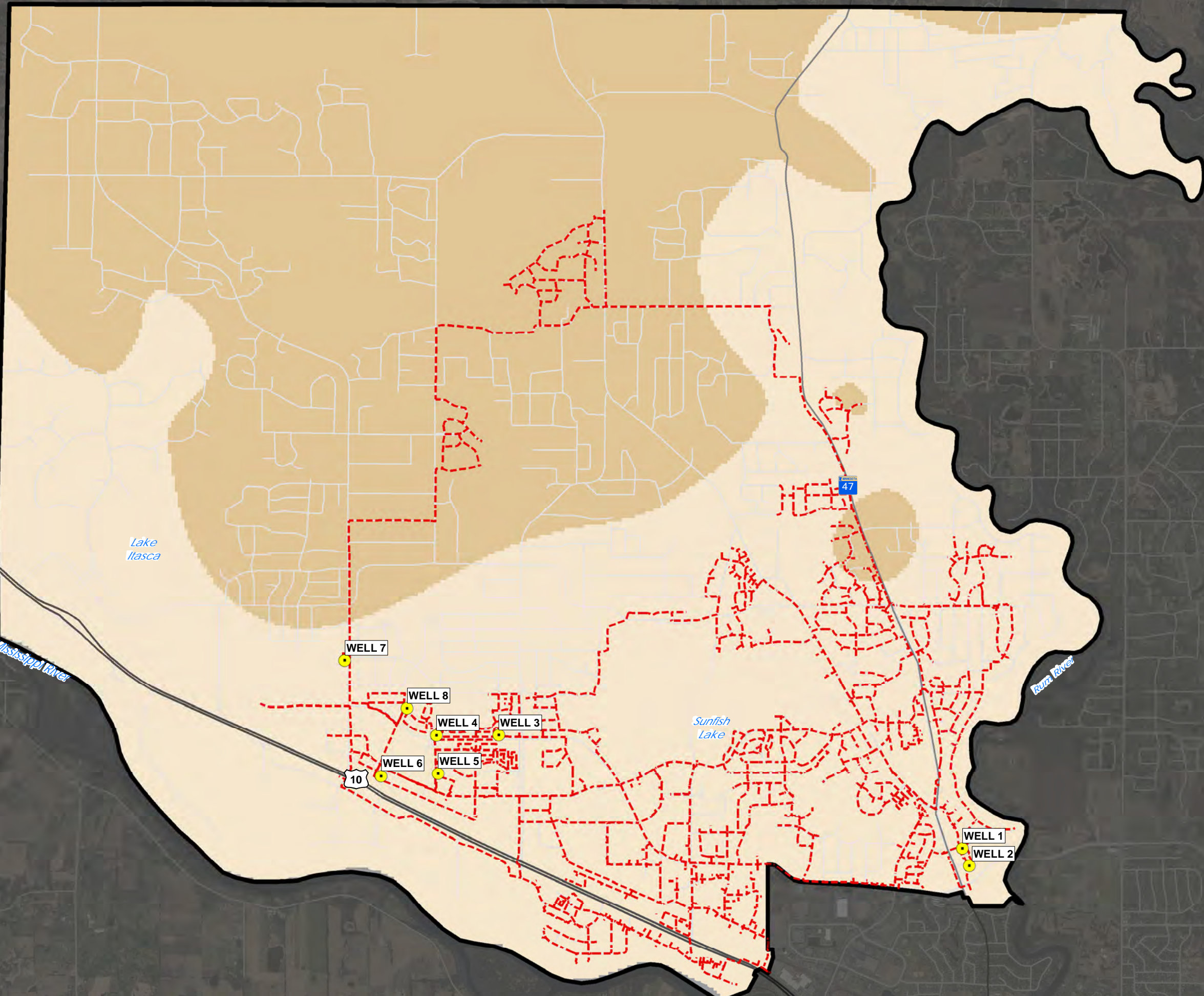

Project: MCES 150732
 Print Date: 11/7/2019
 Map by: Msherrill
 Projection: UTM Zone 15N
 Source: ESRI, SEH Digi MndOT,
 Minnesota Geologic Survey (MGS)

**Figure
8**

Path: S:\KO\M\CES\1507325-Final-dgms\5-drawings\90-GIS\Maps\Geology\Review\Ramse-Project\Figure6.mxd



Legend

-  Municipal Well
 -  Municipal Watermain
 -  Municipality Boundary
- Potentiometric surface elevation**
- ELEVATION**
-  >820 to 860
 -  >860 to 900
 -  City of Ramsey Owned Parcel
 -  Anoka County Parcel Dataset

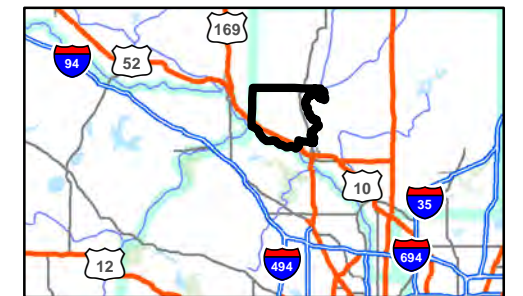

Wonewoc Potentiometric Surface Elevation

Source Water Analysis City of Ramsey Minnesota

This map is neither a legally recorded map nor a survey map and is not intended to be used as one. This map is a compilation of records, information, and data gathered from various sources listed on this map and is to be used for reference purposes only. SEH does not warrant that the Geographic Information System (GIS) Data used to prepare this map are error free, and SEH does not represent that the GIS Data can be used for navigational, tracking, or any other purpose requiring exacting measurement of distance or direction or precision in the depiction of geographic features. The user of this map acknowledges that SEH shall not be liable for any damages which arise out of the user's access or use of data provided.



Project: MCES 150732
Print Date: 11/7/2019
Map by: Msherrill
Projection: UTM Zone 15N
Source: ESRI, SEH Digi MndOT,
Minnesota Geologic Survey (MGS)

Figure
9

Path: S:\KO\MCES\150732\5-Final-dsgn\5-Final-dsgn\GIS\Maps\Geology\Review\Ramsey - Project\Figure 10.mxd

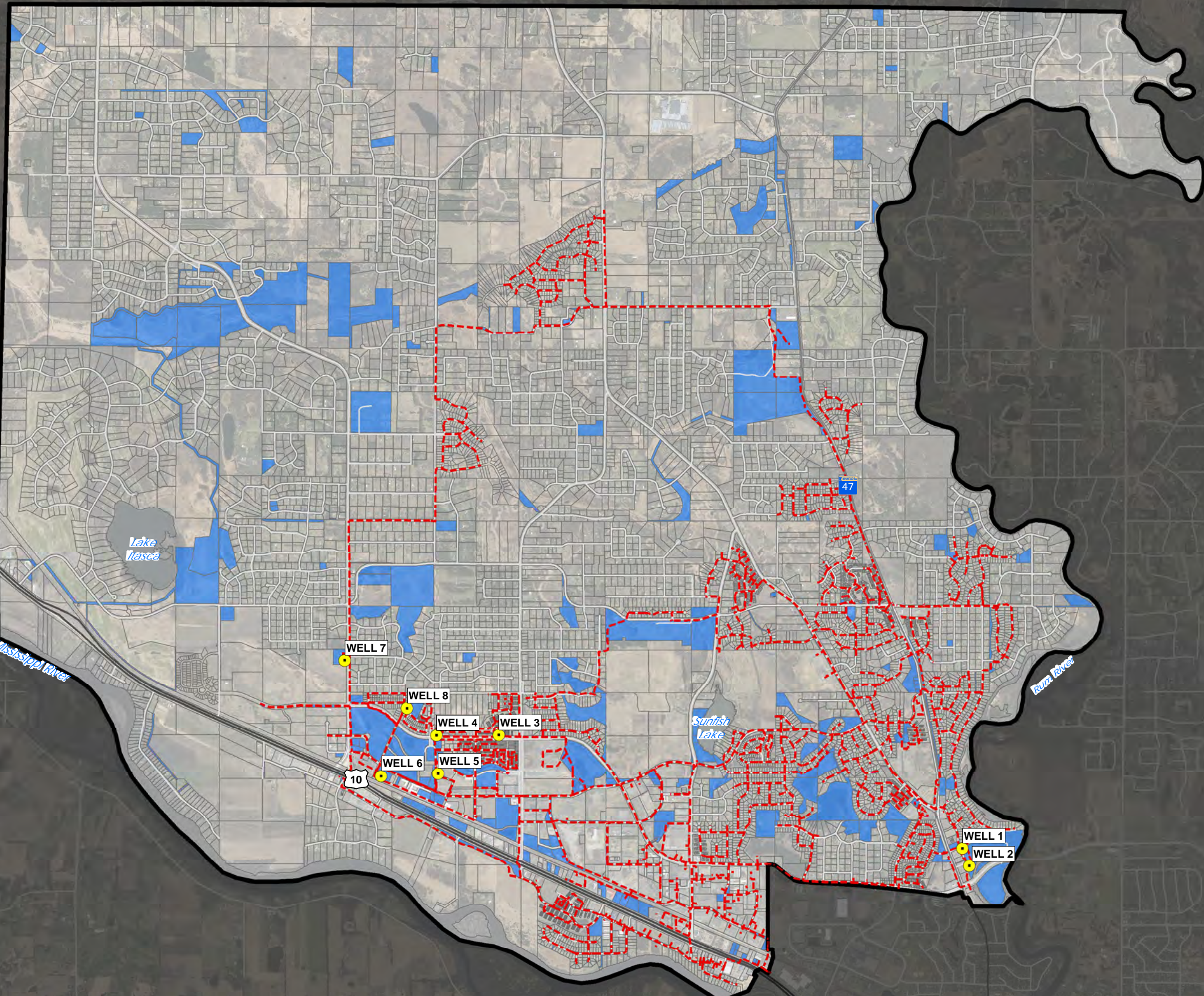

- Legend**
- Municipal Well
 - - - Municipal Watermain
 - Municipality Boundary
 - City of Ramsey Owned Parcel
 - Anoka County Parcel Dataset

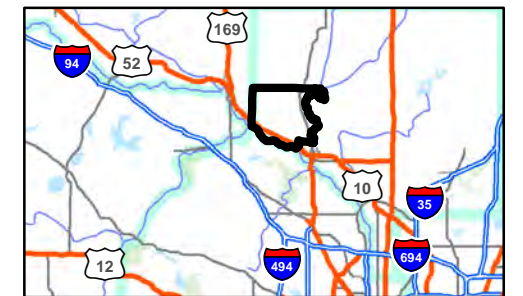
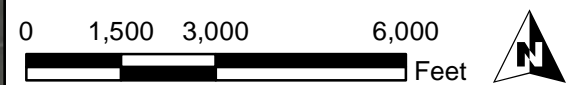

Parcel Data

Source Water Analysis City of Ramsey Minnesota

This map is neither a legally recorded map nor a survey map and is not intended to be used as one. This map is a compilation of records, information, and data gathered from various sources listed on this map and is to be used for reference purposes only. SEH does not warrant that the Geographic Information System (GIS) Data used to prepare this map are error free, and SEH does not represent that the GIS Data can be used for navigational, tracking, or any other purpose requiring exacting measurement of distance or direction or precision in the depiction of geographic features. The user of this map acknowledges that SEH shall not be liable for any damages which arise out of the user's access or use of data provided.



Project: MCES 150732
Print Date: 11/7/2019
Map by: Msherrill
Projection: UTM Zone 15N
Source: ESRI, SEH Digi MndOT,
Minnesota Geologic Survey (MGS)

Figure
10

Path: X:\PT\RAMS\115435-498GIS\mxd\Figure11.mxd

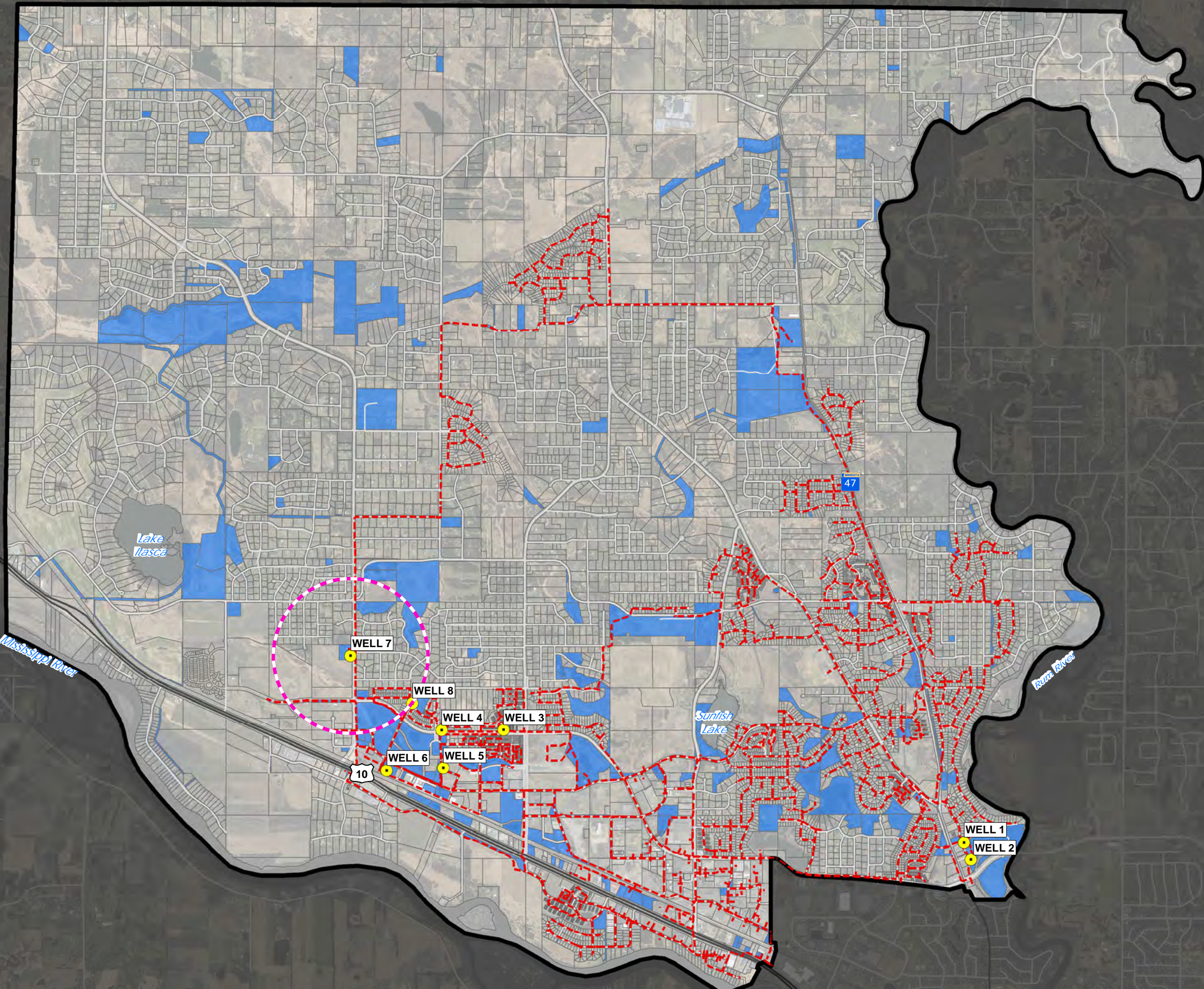

Legend

- Municipal Well
- - - Municipal Watermain
- Municipality Boundary
- City of Ramsey Owned Parcel
- Anoka County Parcel Dataset
- 2400 ft Radius of Influence for 3 feet of Drawdown.

Note:
 Radius of Influence calculation was based upon "Methods for Determining the Proper Spacing of Wells" (USGS, 1961) for a single pumping well.

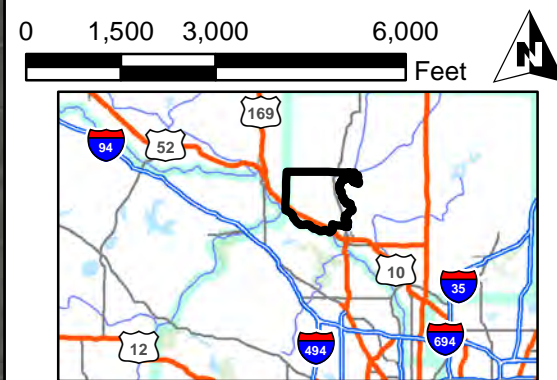

Radius of Influence and Parcel Data
 Source Water Analysis
 City of Ramsey
 Minnesota

This map is neither a legally recorded map nor a survey map and is not intended to be used as one. This map is a compilation of records, information, and data gathered from various sources listed on this map and is to be used for reference purposes only. SEH does not warrant that the Geographic Information System (GIS) Data used to prepare this map are error free, and SEH does not represent that the GIS Data can be used for navigational, tracking, or any other purpose requiring exacting measurement of distance or direction or precision in the depiction of geographic features. The user of this map acknowledges that SEH shall not be liable for any damages which arise out of the user's access or use of data provided.

	Project: MCES 150732 Print Date: 5/19/2020 Map by: Msherrill Projection: UTM Zone 15N Source: ESRI, SEH Digi MNDOT, Minnesota Geologic Survey (MGS)	Figure 11
--	--	--------------

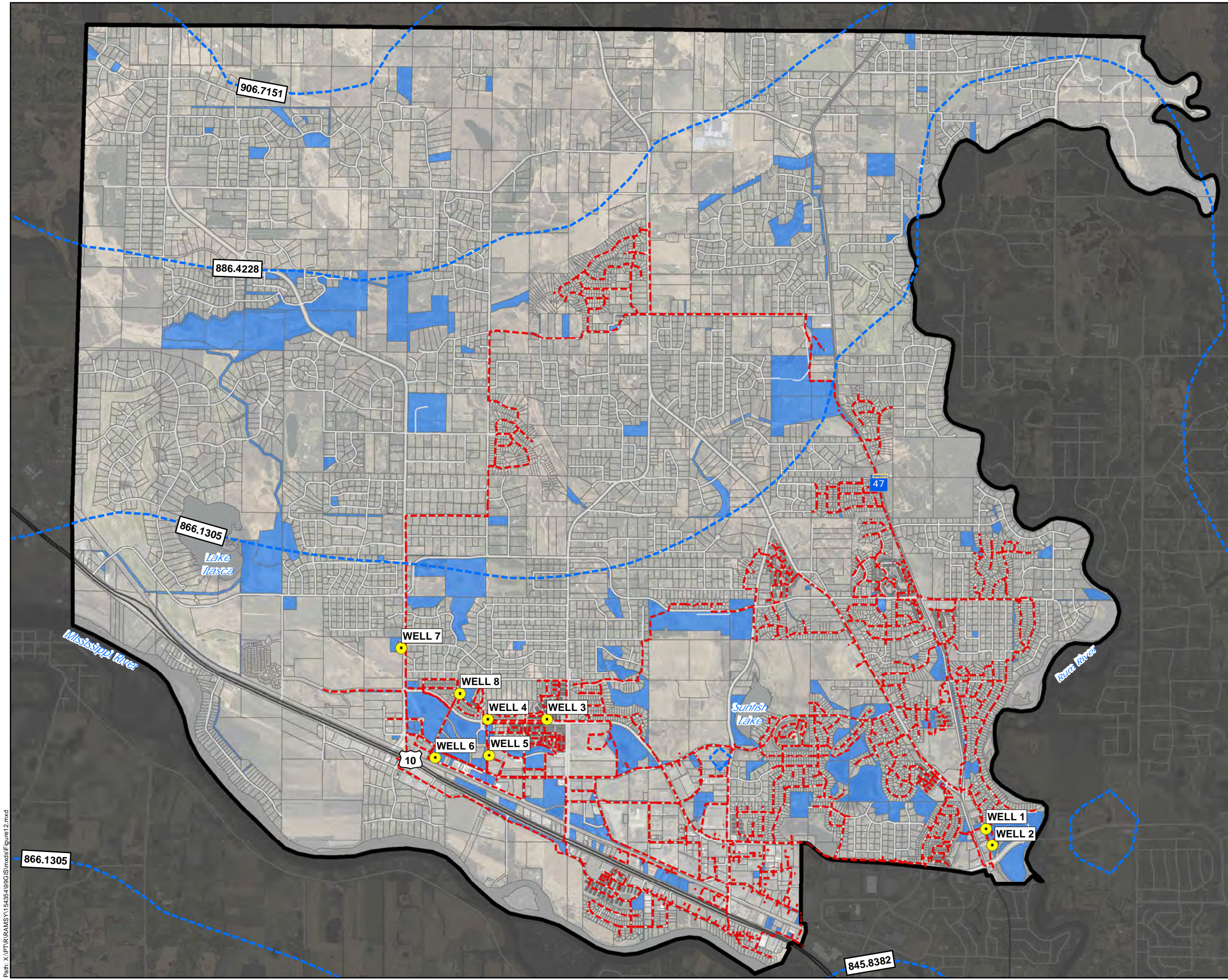

- Legend**
- Municipal Well
 - - - Municipal Watermain
 - Municipality Boundary
 - City of Ramsey Owned Parcel
 - Anoka County Parcel Dataset
 - - - Modeled Steady State Source Water
 - - - Aquifer Water Level with no City Wells Pumping

Note:
 -Source Water Aquifer refers to the Tunnel City and Wonevoc Aquifers.
 -Contours were modeled utilizing the Twin Cities Area Groundwater Flow Model (Metro Model 3, Metropolitan Council and Barr Engineering.)

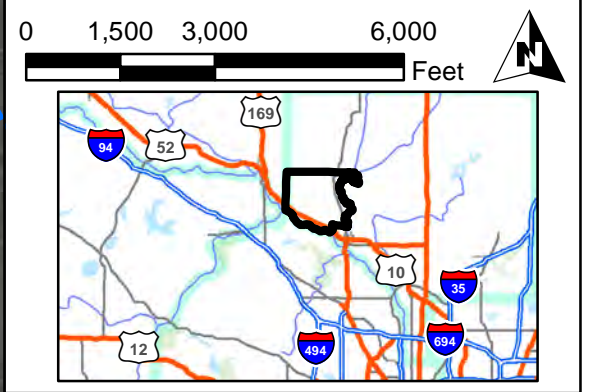

**Present Day - No Pumping Wells
 Aquifer Water Level Contours**

**Source Water Analysis
 City of Ramsey
 Minnesota**

This map is neither a legally recorded map nor a survey map and is not intended to be used as one. This map is a compilation of records, information, and data gathered from various sources listed on this map and is to be used for reference purposes only. SEH does not warrant that the Geographic Information System (GIS) Data used to prepare this map are error free, and SEH does not represent that the GIS Data can be used for navigational, tracking, or any other purpose requiring exacting measurement of distance or direction or precision in the depiction of geographic features. The user of this map acknowledges that SEH shall not be liable for any damages which arise out of the user's access or use of data provided.

	Project: MCES 150732	Figure 12
	Print Date: 5/19/2020	
<small>Map by: Msherrill Projection: UTM Zone 15N Source: ESRI, SEH Digi MndOT, Minnesota Geologic Survey (MGS)</small>		

Path: X:\PT\RAMS\115435-4\98GIS\mxd\Figure12.mxd

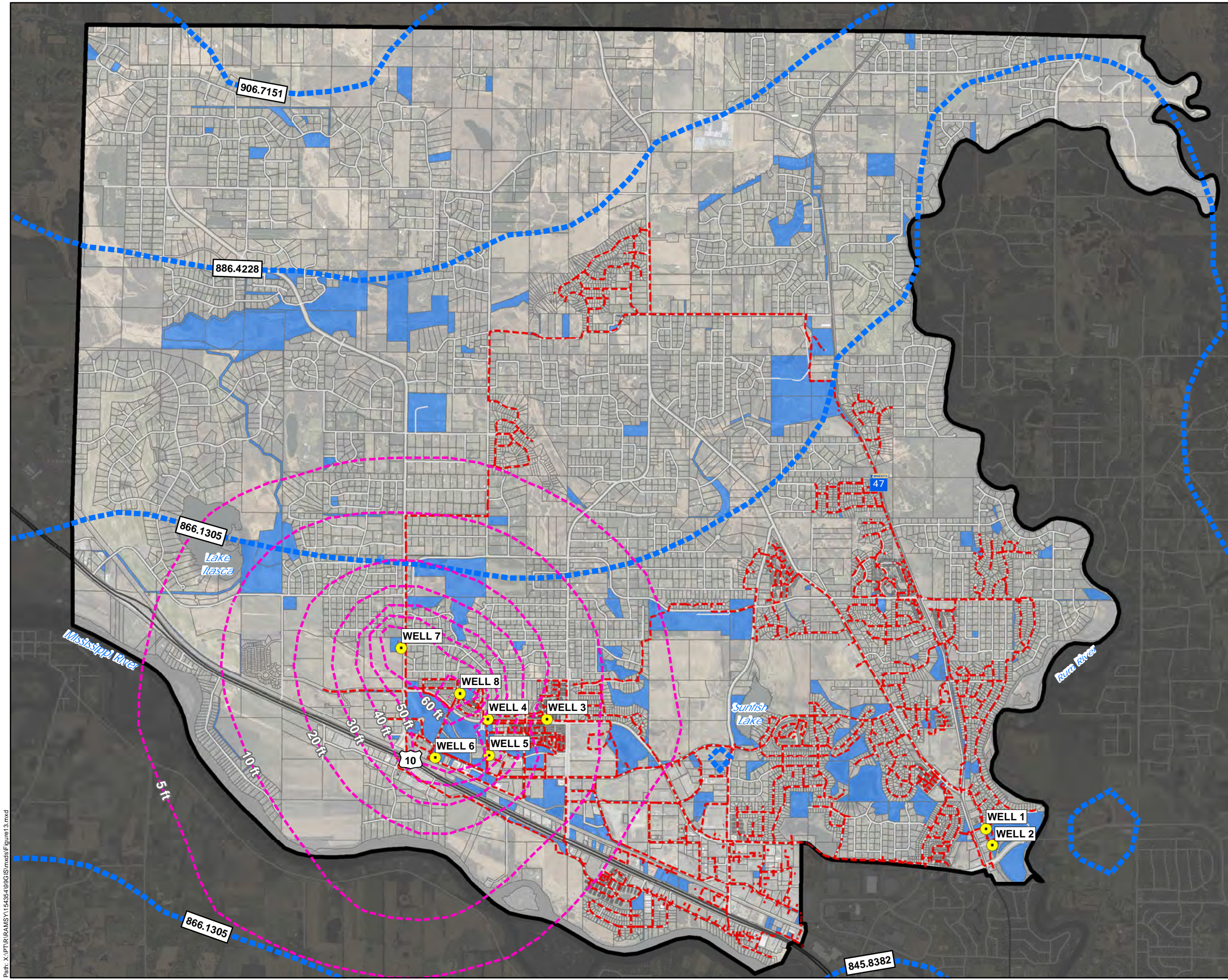

Legend

- Municipal Well
- - - Municipal Watermain
- Municipality Boundary
- City of Ramsey Owned Parcel
- Anoka County Parcel Dataset
- Modeled Steady State Source Water
- Aquifer Water Level with no City Wells Pumping
- - - Feet of Modeled Drawdown from June 13, 2019 Well Pumping

Note:

- Source Water Aquifer refers to the Tunnel City and Wonewoc Aquifers.
- Contours were modeled utilizing the Twin Cities Area Groundwater Flow Model (Metro Model 3, Metropolitan Council and Barr Engineering.)

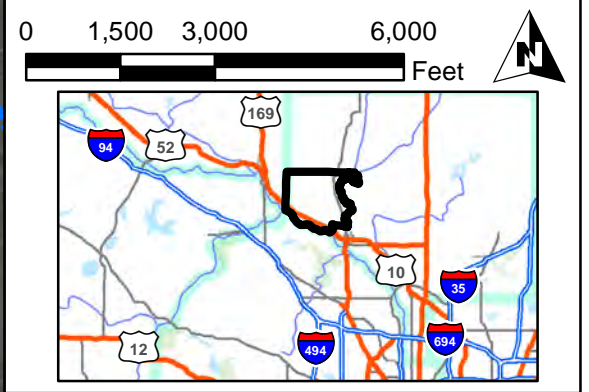

Modeled Drawdown of June 13th Pumping on Aquifer Water Levels

**Source Water Analysis
City of Ramsey
Minnesota**

This map is neither a legally recorded map nor a survey map and is not intended to be used as one. This map is a compilation of records, information, and data gathered from various sources listed on this map and is to be used for reference purposes only. SEH does not warrant that the Geographic Information System (GIS) Data used to prepare this map are error free, and SEH does not represent that the GIS Data can be used for navigational, tracking, or any other purpose requiring exacting measurement of distance or direction or precision in the depiction of geographic features. The user of this map acknowledges that SEH shall not be liable for any damages which arise out of the user's access or use of data provided.

	Project: MCES 150732	Figure 13
	Print Date: 5/19/2020	
<small>Map by: Msherrill Projection: UTM Zone 15N Source: ESRI, SEH Digi MndOT, Minnesota Geologic Survey (MGS)</small>		

Path: X:\PT\RAMS\115435-4\98GIS\mxd\Figure13.mxd

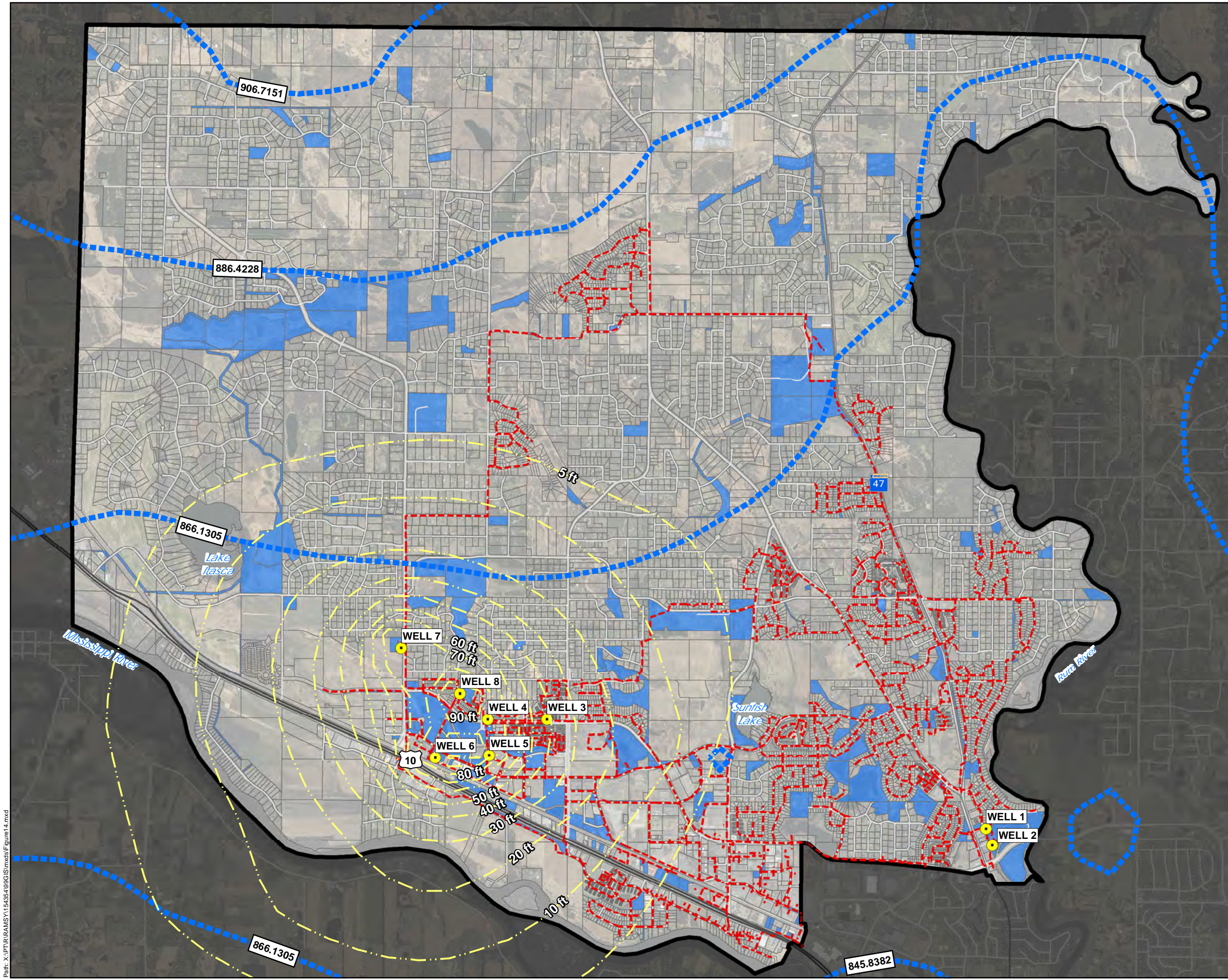

Legend

- Municipal Well
- - - Municipal Watermain
- Municipality Boundary
- City of Ramsey Owned Parcel
- Anoka County Parcel Dataset
- - - Modeled Steady State Source Water
- Aquifer Water Level with no City Wells Pumping
- - - Feet of Modeled Drawdown from Project 2040 Daily Demand Well Pumping of 10.25 Million Gallons

Note:
 -Source Water Aquifer refers to the Tunnel City and Wonevoc Aquifers.
 -Contours were modeled utilizing the Twin Cities Area Groundwater Flow Model (Metro Model 3, Metropolitan Council and Barr Engineering.)

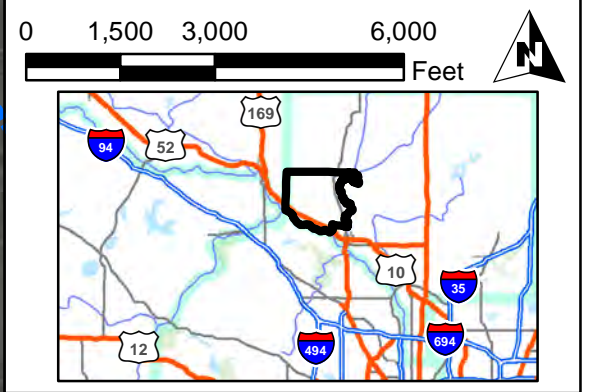

Modeled Drawdown of 2040 Daily Demand on Aquifer Water Levels

**Source Water Analysis
 City of Ramsey
 Minnesota**

This map is neither a legally recorded map nor a survey map and is not intended to be used as one. This map is a compilation of records, information, and data gathered from various sources listed on this map and is to be used for reference purposes only. SEH does not warrant that the Geographic Information System (GIS) Data used to prepare this map are error free, and SEH does not represent that the GIS Data can be used for navigational, tracking, or any other purpose requiring exacting measurement of distance or direction or precision in the depiction of geographic features. The user of this map acknowledges that SEH shall not be liable for any damages which arise out of the user's access or use of data provided.

	Project: MCES 150732	Figure 14
	Print Date: 5/19/2020	
<small>Map by: Msherrill Projection: UTM Zone 15N Source: ESRI, SEH Digi MndOT, Minnesota Geologic Survey (MGS)</small>		

Path: X:\PT\RAMS\115435-4\98GIS\mxd\Figure14.mxd

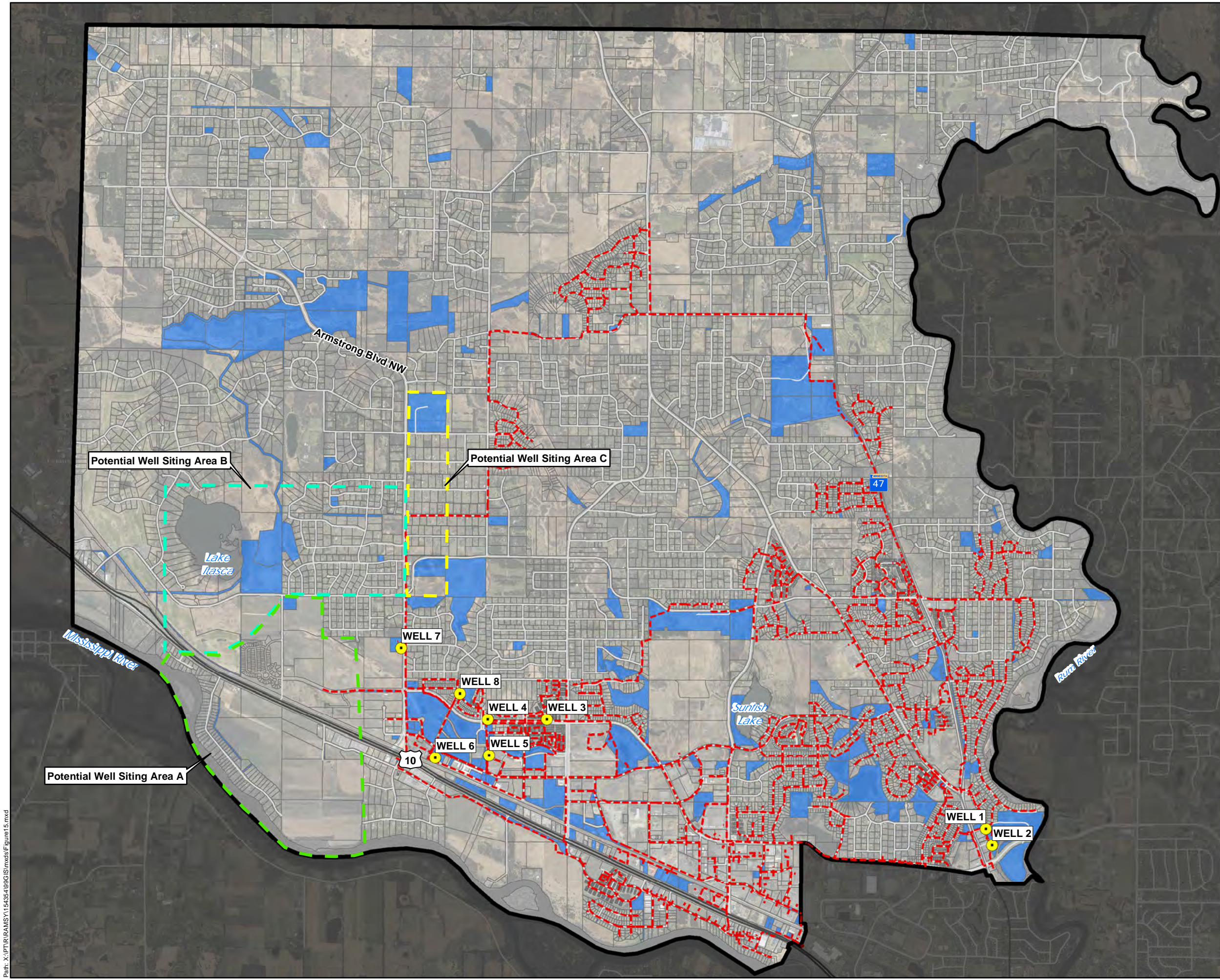

- Legend**
- Municipal Well
 - - - Municipal Watermain
 - Municipality Boundary
 - City of Ramsey Owned Parcel
 - Anoka County Parcel Dataset
- Potential Well Sites**
- Potential Well Siting Area A
 - Potential Well Siting Area B
 - Potential Well Siting Area C

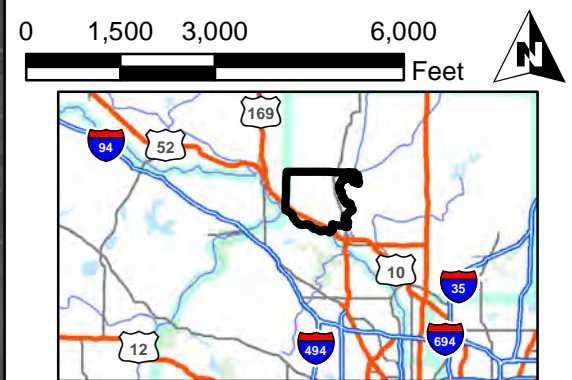

Potential Well Sites
Source Water Analysis
City of Ramsey
Minnesota

This map is neither a legally recorded map nor a survey map and is not intended to be used as one. This map is a compilation of records, information, and data gathered from various sources listed on this map and is to be used for reference purposes only. SEH does not warrant that the Geographic Information System (GIS) Data used to prepare this map are error free, and SEH does not represent that the GIS Data can be used for navigational, tracking, or any other purpose requiring exacting measurement of distance or direction or precision in the depiction of geographic features. The user of this map acknowledges that SEH shall not be liable for any damages which arise out of the user's access or use of data provided.

	Project: MCES 150732 Print Date: 6/5/2020 Map by: Msherrill Projection: UTM Zone 15N Source: ESRI, SEH Digi MndOT, Minnesota Geologic Survey (MGS)	Figure 15
--	---	--------------------------------

Path: X:\PT\RAMS\115435-498\GIS\mxd\Figure15.mxd

Appendix E

Pilot Study



Pilot Study Report

Water Treatment Plant

City of Ramsey, Minnesota

RAMSY 154354 | June 18, 2020



Building a Better World
for All of Us®

Engineers | Architects | Planners | Scientists



Building a Better World
for All of Us®

Contents

Certification Page
Contents

- 1 Introduction1
 - 1.1 Background1
 - 1.2 Objectives.....1
- 2 Existing Facilities1
 - 2.1 Wells.....1
- 3 Pilot Study2
 - 3.1 Pilot Testing Processes2
 - 3.2 Sampling and Analysis4
- 4 Pilot Study Results4
 - 4.1 Well No. 3 Results5
 - 4.2 Well No. 4 Results6
- 5 Conclusions and Recommendations8
 - 5.1 Aeration8
 - 5.2 Detention8
 - 5.3 Chemical Feed8
 - 5.4 Filtration.....8

List of Tables

- Table 1 – Pilot Study Filter Characteristics.....4
- Table 2 – Well No. 3 Raw Water Quality5
- Table 3 – Well No. 3 Chemical Dosages.....5
- Table 4 – Well No. 3 Finished Water Quality.....6
- Table 5 – Well No. 4 Raw Water Quality6

Contents (continued)

Table 6 – Well No. 4 Chemical Dosages.....	7
Table 7 – Well No. 4 Finished Water Quality.....	7

List of Figures

Figure 1 – Pilot Study Train 1	2
Figure 2 – Pilot Study Train 2	3
Figure 3 – Well #3 Manganese Results.....	9
Figure 4 – Well #3 Iron Results	9
Figure 5 – Well #4 Manganese Results.....	10
Figure 6 – Well #4 Iron Results	10

Pilot Study Report

Water Treatment Plant

Prepared for the City of Ramsey, Minnesota

1 Introduction

1.1 Background

SEH was contracted by the City of Ramsey to conduct a centralized water treatment plant feasibility study. As part of the study, SEH conducted a pilot study to consider options for the removal of iron and manganese from their water supply. The water quality in Ramsey is high in both iron and manganese with levels exceeding the United States Environmental Protection Agency (US EPA) secondary standards of 0.3 mg/L and 0.05 mg/L respectively. Along with the manganese secondary standard, Ramsey's average manganese levels exceed Minnesota Department of Health's (MDH's) Health Based Value (HBV) of 0.1 mg/L for bottle-fed infants less than one year of age.

1.2 Objectives

The objectives of the study were to evaluate the effectiveness of various treatment methods for removing iron and manganese, and then to select treatment methods for the design of a Water Treatment Plant for the City of Ramsey.

The study included the following objectives:

- Evaluate the effectiveness of chlorine and permanganate for the removal of iron and manganese;
- Establish filter run lengths;
- Evaluate filter loading rates;
- Select the filter media type that provides the best removal of iron and manganese, and;
- Evaluate the use of aeration and detention as part of the treatment process.

2 Existing Facilities

2.1 Wells

The City of Ramsey has eight wells all located in the southern part of town north of U.S. Highway 10. The City's original two wells, Wells No. 1 and 2, are located in the southeast part of town, while the other wells are all located in the southwest part of town. The wells are capable of producing approximately 11 million gallons per day, although the treatment plant would be located within the southwest well field and thus would not be fed by Wells No. 1 or 2, making the potential treatment capacity 9.5 million gallons per day.

Current treatment at the wells consists of chemical treatment including polyphosphate for iron and manganese sequestration, gas chlorine for disinfection, and fluoride for dental health.

3 Pilot Study

The pilot study was conducted in the SEH pilot water plant trailer. Equipment used for the pilot study included chemical feed systems, an aerator, detention tank, and filter columns (filters). Train 1 of the study utilized direct filtration where the well water was treated with chemical injections of chlorine (sodium hypochlorite) and potassium permanganate, and then filtered through filters with two different media types. Train 2 of the study utilized the chemical injections and two different filter media types, but included aeration prior to the chemical injections, and detention prior to filtration. Sampling as part of the pilot study were conducted and analyzed by SEH's pilot plant operator.

3.1 Pilot Testing Processes

The pilot study was conducted for Ramsey's Wells No. 3 and 4 to establish the efficiency and reliability of the two treatment processes and filter media types to remove iron and manganese. Processes for the pilot study were selected based on the concentrations of iron and manganese, and on prior experience. The figures below show the processes for Train 1 and Train 2.

Figure 1 – Pilot Study Train 1

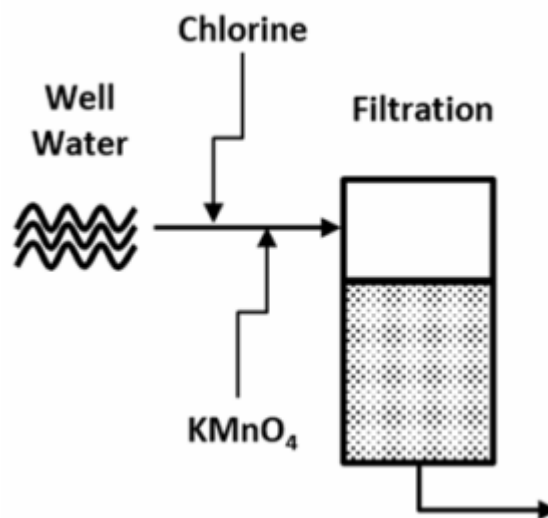
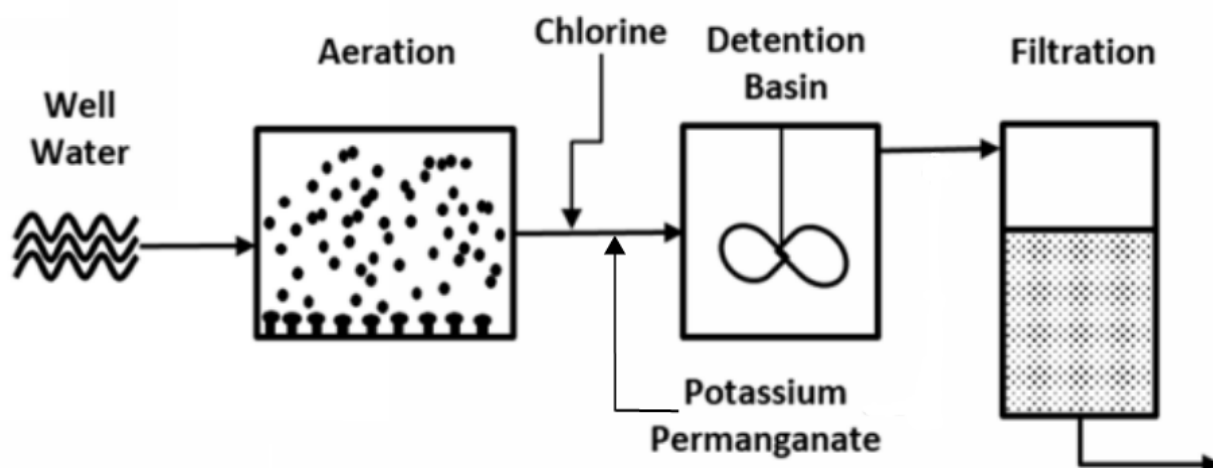

Figure 2 – Pilot Study Train 2



3.1.1 Forced Draft Aerator

The SEH pilot water plant utilized a forced draft aerator, which consists of an aerator column, packing material, and a blower. During treatment of the water for Train 2, water was pumped from the well into the pilot water plant aerator, and then percolated down through the packing material in the aerator column as air was blown up through the packing material. Aeration of water is done to oxidize the iron into solids so that they can be filtered out. Aeration of water can also remove dissolved gases in water such as hydrogen sulfide.

3.1.2 Detention Tank

After aeration during Train 2, a detention tank in the pilot water plant was used to provide additional reaction time for chlorine to oxidize iron and potassium permanganate to oxidize manganese in the water. For this study, the system was set up to provide 30 minutes of detention before filtration.

3.1.3 Chemical Feed System

The chemicals used for the pilot study included chlorine, in the form of sodium hypochlorite, and potassium permanganate (KMnO_4). While chlorine is used for oxidizing iron, potassium permanganate is used for the oxidation of manganese. Both chemicals are commonly used in treatment systems for the removal of iron and manganese. The sodium hypochlorite solution was fed at a strength of 15 grams per liter (gpl). Potassium permanganate was fed at a strength of 4 gpl.

The chemical feed systems used in the pilot study included Qdos peristaltic metering pumps capable of feeding a maximum of 31 gallons per hour (gph).

Chemical addition was measured using calibration columns for each chemical feed pump. The volume (in milliliters) of each chemical pumped was measured per unit of time and the dosage was calculated based on the flow to the individual treatment trains.

3.1.4 Filters

The SEH Pilot Water Plant contains four filter columns (filters) that each measure 8 inches in diameter and 72 inches tall. The resulting surface area for filtration of each filter is 0.35 ft². The filters each have a 0.75 inch inlet, 1.5 inch backwash waste outlets, underdrains, air release system, rate of flow meters, sample taps, and filter media. Pressure taps are located on the inlet and outlet of each filter to obtain filter head loss by comparing the two pressures. For the Ramsey pilot study, Filters 1 and 2 (Train 1) were operated without aeration and detention. Filters 3 and 4 (Train 2) were operated with aeration and detention. Each filter was supplied 1.05 gpm to achieve a target filtration rate of 3.0 gpm/ft² for this study. Each type of filter media used in the study was new and had not been used in other studies. The filters were backwashed with a combination of air and water between filter runs.

Table 1 – Pilot Study Filter Characteristics

Filter	Media	Filtration Rate (gpm/ft ²)	Effective Size (mm)	Media Depth (in)
1	Greensand	3	0.30-0.35	18
	Anthracite		0.9-1.0	12
2	Silica Sand	3	0.45-0.55	18
	Anthracite		0.9-1.0	12
3	Greensand	3	0.30-0.35	18
	Anthracite		0.9-1.0	12
4	Silica Sand	3	0.45-0.55	18
	Anthracite		0.9-1.0	12

3.2 Sampling and Analysis

Sampling and analysis was completed by the onsite SEH pilot plant operator. Field testing for iron and manganese was conducted using a Hach DR/890 Portable Colorimeter, and was done for the raw water and from the effluent of each filter. Testing for iron was conducted using the Hach Method 8147 (DR800 FerroZine Solution Pillow), which has a range of 0-1.3 mg/L iron (Fe), and an estimated detection limit of 0.011 mg/L Fe. Testing for manganese was conducted using the Hach Method 8149 (DR800 PAN), which has a range of 0-0.70 mg/L manganese (Mn), and an estimated detection limit of 0.020 mg/L Mn. Temperature and pH analyses were conducted using a Hach HQ 40 pH meter, and was done for the raw water. Samples for the analysis of chlorine were collected from the effluent of each filter and analyzed using the Hach DR/890 Portable Colorimeter. The chlorine demand was calculated by subtracting the residual chlorine after filtration from the dose of chlorine added to the raw water to oxidize iron. The results of the sampling and subsequent analysis are presented in the remainder of this report.

4 Pilot Study Results

As discussed, the pilot study was conducted for Ramsey's Wells No. 3 and 4 to establish the efficiency and reliability of the two treatment processes, as well as the two filter media types, to remove iron and manganese. Identical pilot studies were conducted at both wells. The purpose of this was to determine how well the treatment processes would do with more than one source

water. The finished water quality met the EPA secondary standards for iron and manganese, as well as MDH's HBV for manganese, for both treatment processes and filter media types.

4.1 Well No. 3 Results

4.1.1 Raw Water Quality

The pilot study for Well No. 3 was completed between January 21, 2020 and January 22, 2020. Well No. 3 currently pumps approximately 1,450 gpm directly into the distribution system with polyphosphate, chlorine, and fluoride added in a shared pump house with Well No. 4. Table 2 below summarizes the raw water results collected from Well No. 3 during the pilot study.

Table 2 – Well No. 3 Raw Water Quality

Iron (mg/L)			Manganese (mg/L)			pH		
Min.	Avg.	Max	Min.	Avg.	Max.	Min.	Avg.	Max.
0.500	0.640	0.850	0.160	0.200	0.240	7.46	7.72	7.85

Results from the raw water sampling show that Well No. 3 exceeds EPA's secondary standards for iron and manganese, which can cause aesthetic water quality issues related to color, taste, sediment, and staining. Well No. 3 also exceeds MDH's HBV 0.1 mg/L for manganese for bottled infants less than one year of age. Infants who drink water with manganese above 0.1 mg/L may develop learning and behavior problems.

4.1.2 Water Treatment

Water from Well No. 3 went through both treatment trains provided by the SEH pilot water treatment plant. Train 1 utilized direct filtration through Filters 1 and 2 after chlorine and potassium permanganate injection, while Train 2 utilized aeration and detention prior to filtration through Filters 3 and 4. With Train 2, aeration was provided prior to chemical injection to help oxidize iron, followed by chlorine and potassium permanganate injection, and then 30 minutes of detention time to allow for adequate chemical reaction time before filtration. The chemical doses to treat water from Well No. 3 are provided in Table 3. All four filters in the pilot water plant were operated at a rate of 3.0 gpm/ft².

Table 3 – Well No. 3 Chemical Dosages

Train 1 – Filters 1 and 2 (Direct Filtration)					
Chlorine (mg/L as Cl ₂)			KMnO ₄ (mg/L)		
Min.	Avg.	Max.	Min.	Avg.	Max.
2.15	2.92	3.58	0.49	0.49	0.49
Train 2 – Filters 3 and 4 (Aeration and Detention)					
Chlorine (mg/L as Cl ₂)			KMnO ₄ (mg/L)		
Min.	Avg.	Max.	Min.	Avg.	Max.
1.95	3.24	4.53	0.10	0.10	0.10

The chlorine dosages for the two treatment trains were similar, although the chlorine dosage with Train 2 may be able to be reduced as aeration provides significant iron oxidation, and 30 minutes

of detention allows for additional chemical reaction time to increase iron oxidation. The potassium permanganate dosage in Train 2 was able to be lowered to about a fifth of that in Train 1, as the added chemical reaction time with 30 minutes of detention increases manganese oxidation.

4.1.3 Finished Water Quality

The SEH pilot water plant was able to treat water from Well No. 3 to levels that meet the EPA secondary standards, as well as MDH's HBV for manganese. In fact, no sample result exceeded the EPA secondary standards, and both treatment trains were able to remove both iron and manganese on average below the method detection limits of 0.011 mg/L and 0.020 mg/L respectively.

The finished water quality for Well No. 3 during the pilot study is summarized in Table 4 below.

Table 4 – Well No. 3 Finished Water Quality

Filter	Iron (mg/L)			Manganese (mg/L)		
	Min.	Avg.	Max.	Min.	Avg.	Max.
1	nd	nd	0.040	nd	nd	0.043
2	nd	nd	0.020	nd	nd	nd
3	nd	nd	0.020	nd	nd	0.048
4	nd	nd	nd	nd	nd	nd

Notes: nd = below method detection limit

The use of detention in Train 2 did not provide a significant treatment advantage over Train 1 in removing iron and manganese, although the use of aeration in Train 2 provided slightly better results in the removal of iron. There also wasn't a significant difference in treatment effectiveness between the two filter media types, although Filters 1 and 3 each had at least one spiked result for manganese that approached the secondary standard.

4.2 Well No. 4 Results

4.2.1 Raw Water Quality

The pilot study for Well No. 4 was completed between January 20, 2020 and January 21, 2020. Well No. 4 currently pumps approximately 850 gpm directly into the distribution system with polyphosphate, chlorine, and fluoride added in a shared pump house with Well No. 3. Table 5 below summarizes the raw water results collected from Well No. 4 during the pilot study.

Table 5 – Well No. 4 Raw Water Quality

Iron (mg/L)			Manganese (mg/L)			pH		
Min.	Avg.	Max.	Min.	Avg.	Max.	Min.	Avg.	Max.
0.180	0.240	0.360	0.035	0.392	0.360	7.51	7.61	7.71

Results from the raw water sampling show that Well No. 4 exceeds EPA's secondary standards for iron and manganese, which can cause aesthetic water quality issues related to color, taste,

sediment, and staining. Well No. 4 also exceeds MDH's HBV 0.1 mg/L for manganese for bottled infants less than one year of age. Infants who drink water with manganese above 0.1 mg/L may develop learning and behavior problems.

4.2.2 Water Treatment

Like Well No. 3, water from Well No. 4 went through both treatment trains provided by the SEH pilot water treatment plant. The chemical doses to treat water from Well No. 4 are provided in Table 3. All four filters in the pilot water plant were operated at a rate of 3.0 gpm/ft².

Table 6 – Well No. 4 Chemical Dosages

Train 1 – Filters 1 and 2 (Direct Filtration)					
Chlorine (mg/L as Cl ₂)			KMnO ₄ (mg/L)		
Min.	Avg.	Max.	Min.	Avg.	Max.
1.43	2.57	3.43	0.49	0.49	0.52
Train 2 – Filters 3 and 4 (Aeration and Detention)					
Chlorine (mg/L as Cl ₂)			KMnO ₄ (mg/L)		
Min.	Avg.	Max.	Min.	Avg.	Max.
1.95	2.66	2.72	0.21	0.21	0.21

The chlorine dosages for the two treatment trains were similar, although the chlorine dosage with Train 2 may be able to be reduced as aeration provides significant iron oxidation, and 30 minutes of detention allows for additional chemical reaction time to increase iron oxidation. The potassium permanganate dosage in Train 2 was able to be lowered to less than half of that in Train 1, as the added chemical reaction time with 30 minutes of detention increases manganese oxidation.

4.2.3 Finished Water Quality

The SEH pilot water plant was able to treat water from Well No. 4, on average, to levels that meet the EPA secondary standards, as well as MDH's HBV for manganese. Although the average iron and manganese levels were below those standards, the pilot water plant was not able to remove iron below the method detection limit on average like it did with Well No. 3. Filter 4 also saw a spike in manganese at the beginning of the filter run, which was above the MDH HBV, but quickly reduced manganese below the secondary standard and MDH HBV thereafter.

The finished water quality for Well No. 4 during the pilot study is summarized in Table 7 below.

Table 7 – Well No. 4 Finished Water Quality

Filter	Iron (mg/L)			Manganese (mg/L)		
	Min.	Avg.	Max.	Min.	Avg.	Max.
1	nd	0.018	0.080	nd	nd	0.044
2	nd	0.014	0.080	nd	nd	0.028
3	nd	0.014	0.080	nd	nd	0.031
4	nd	0.015	0.090	nd	nd	0.128

Notes: nd = below method detection limit

The use of detention and aeration in Train 2 did not provide a significant treatment advantage over Train 1 in removing iron and manganese. There also wasn't a significant difference in treatment effectiveness between the two filter media types, although Filter 4 saw the spike in manganese that was above the secondary standard and MDH HBV.

5 Conclusions and Recommendations

The SEH pilot water plant was able to treat water from Well No. 3 and Well No. 4 to concentrations below the EPA secondary standards for iron and manganese, as well as the MDH HBV for manganese. Implementing either treatment trains at full-scale would allow the City of Ramsey to provide aesthetically pleasing as it relates to iron and manganese, as well as provide safe drinking water to the residents as it relates to manganese.

5.1 Aeration

Aeration of the water provided better results in terms of iron removal for Well No. 3, which had much higher raw water iron levels than Well No. 4, but provided similar results in terms of iron removal for Well No. 4. It is expected that the benefits of aeration will be more pronounced in water quality similar to that of Well No. 3. Based on the results and on previous experience, the use of an aerator may be preferred as it provides an additional layer in the removal of iron, and may also provide additional treatment benefits such as the removal of dissolved gases like hydrogen sulfide.

5.2 Detention

The addition of a detention tank did not provide a significant difference in treatment effectiveness for iron and manganese removal, but it did allow for the potassium permanganate dosage to be lowered. Although 30 minutes of detention was suitable for the removal of iron and manganese, and allowed for the reduction in the potassium permanganate dosage, it is not needed to provide quality water for the City of Ramsey. If a water treatment plant is pursued, the City should compare the cost savings of reducing the potassium permanganate dosage with the construction cost of a detention tank.

5.3 Chemical Feed

The pilot study evaluated the use of chlorine and potassium permanganate as oxidants. Feed rates are within normal ranges for the type of water treated. It is recommended to use these chemicals for a full-scale design, although chlorine may be fed as sodium hypochlorite solution or gas chlorine, and potassium permanganate may be fed as sodium permanganate instead.

5.4 Filtration

Both filter media types were effective in removing iron and manganese and successfully operated at a loading rate of 3.0 gpm/ft², but there wasn't a significant difference in effectiveness. Although there wasn't a significant difference between the two filter media types, SEH recommends the use of 12 inches of anthracite over 18 inches of Greensand Plus™, rather than 12 inches of anthracite over 18 inches of silica sand for full-scale filters. This is because Greensand Plus™ is a filter media that is coated with manganese dioxides that further aid in the removal of manganese.

Figure 3 – Well #3 Manganese Results

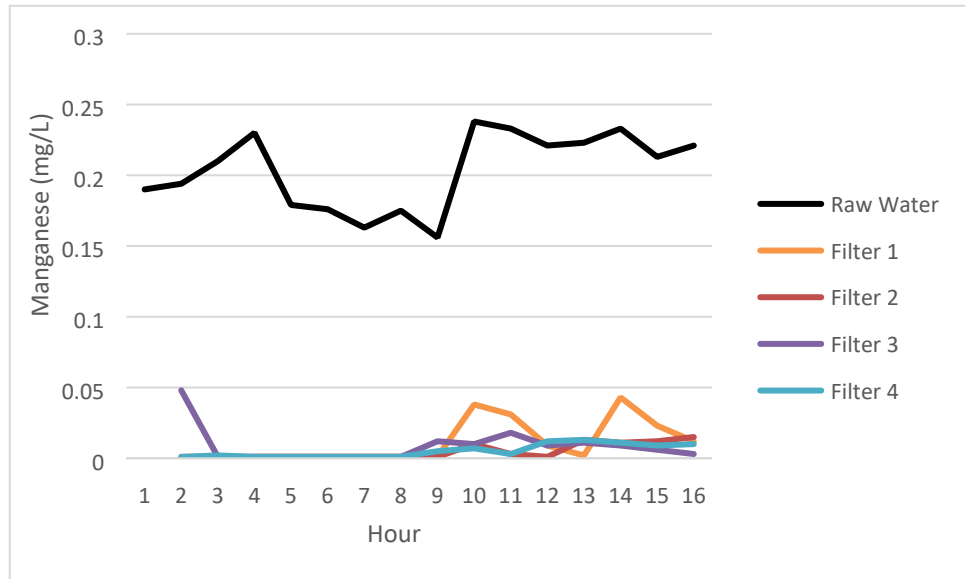

Figure 4 – Well #3 Iron Results

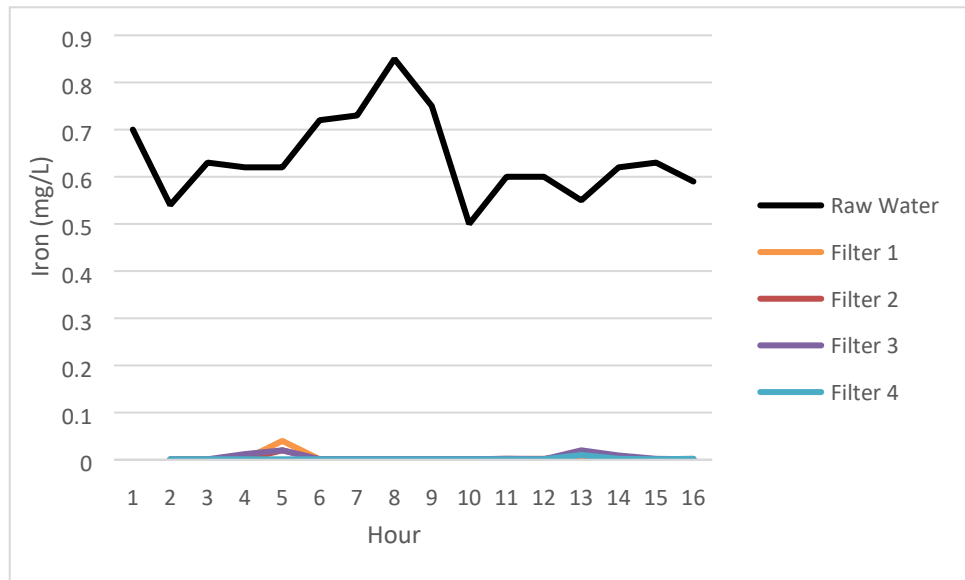

Figure 5 – Well #4 Manganese Results

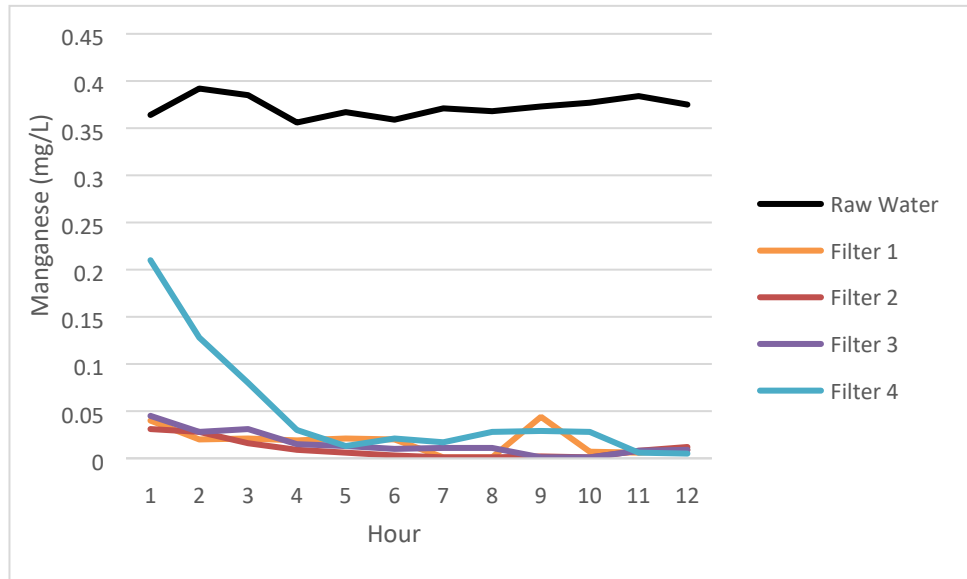
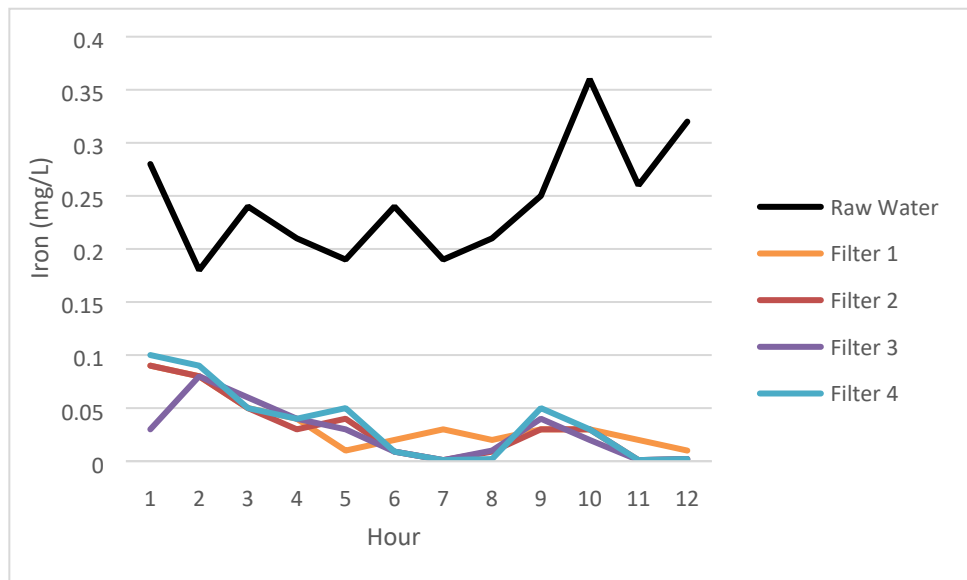

Figure 6 – Well #4 Iron Results



dmk



Building a Better World for All of Us[®]

Sustainable buildings, sound infrastructure, safe transportation systems, clean water, renewable energy and a balanced environment. Building a Better World for All of Us communicates a company-wide commitment to act in the best interests of our clients and the world around us.

We're confident in our ability to balance these requirements.

[Join Our Social Communities](#)



Appendix F

Gravity Filter Layouts

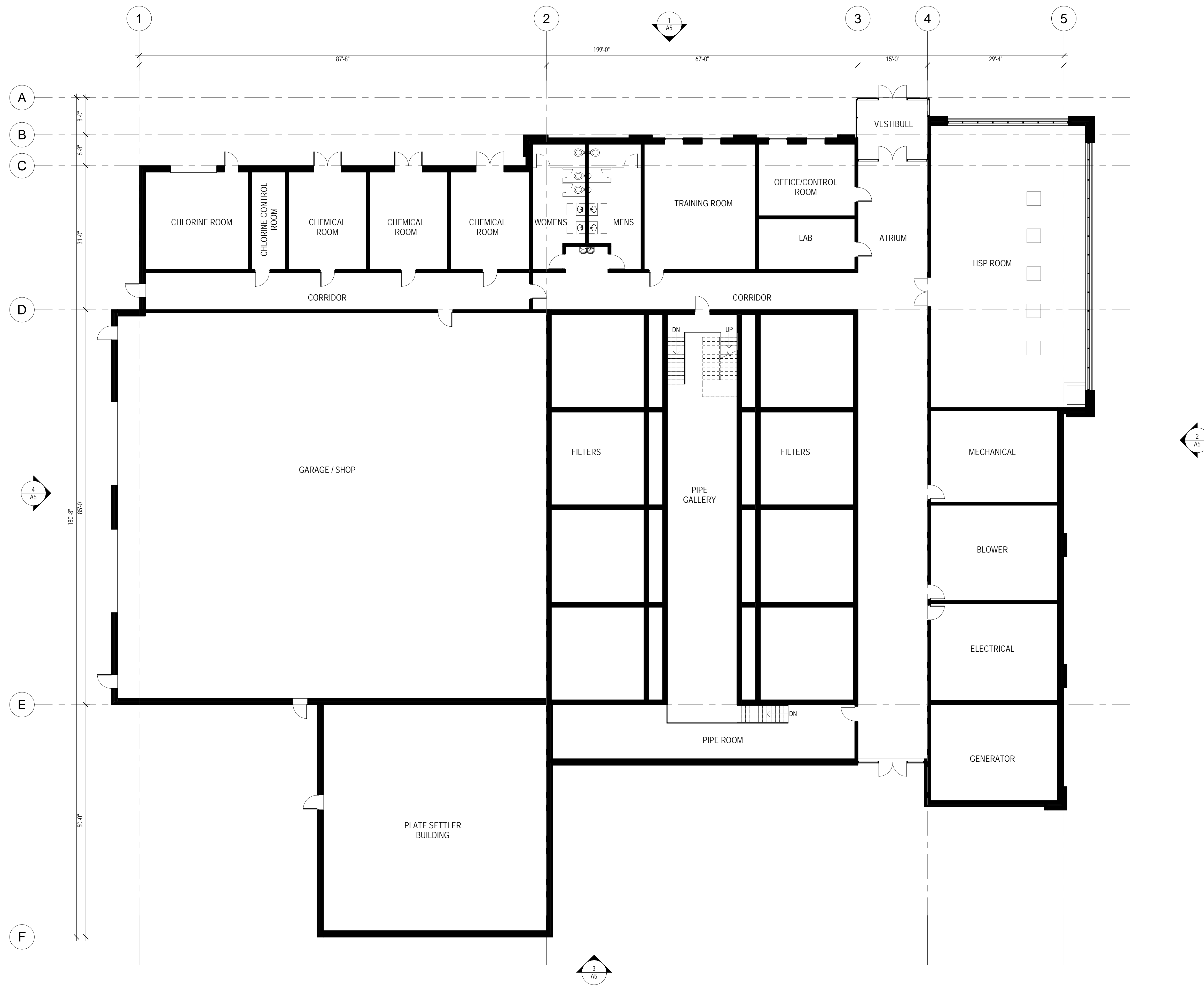

1
A3 MAIN LEVEL FLOOR PLAN - ALTERNATIVE 1 - WITH GARAGE
3/32" = 1'-0"

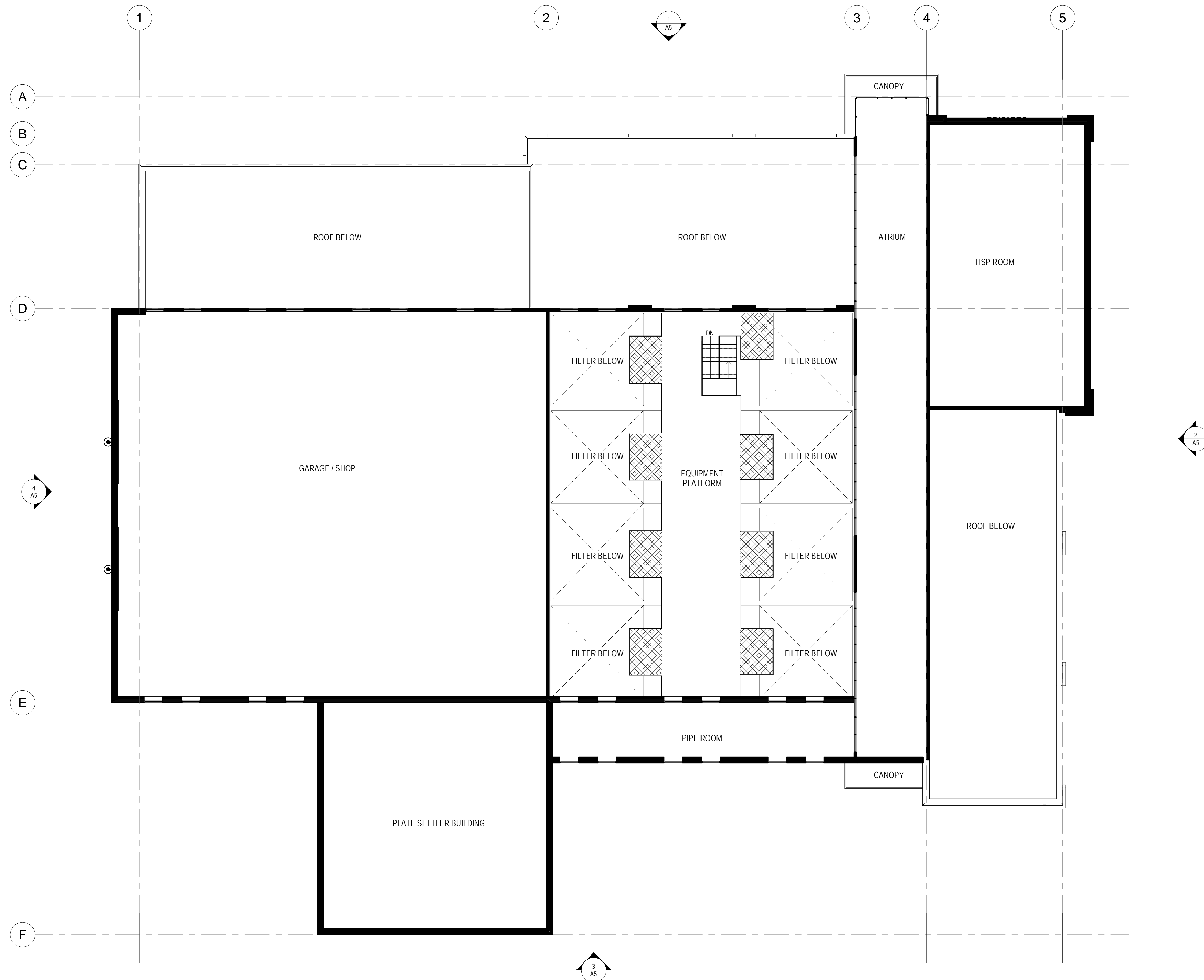

1 UPPER LEVEL FLOOR PLAN - ALTERNATIVE 1 - WITH GARAGE
 A4 3/32" = 1'-0"

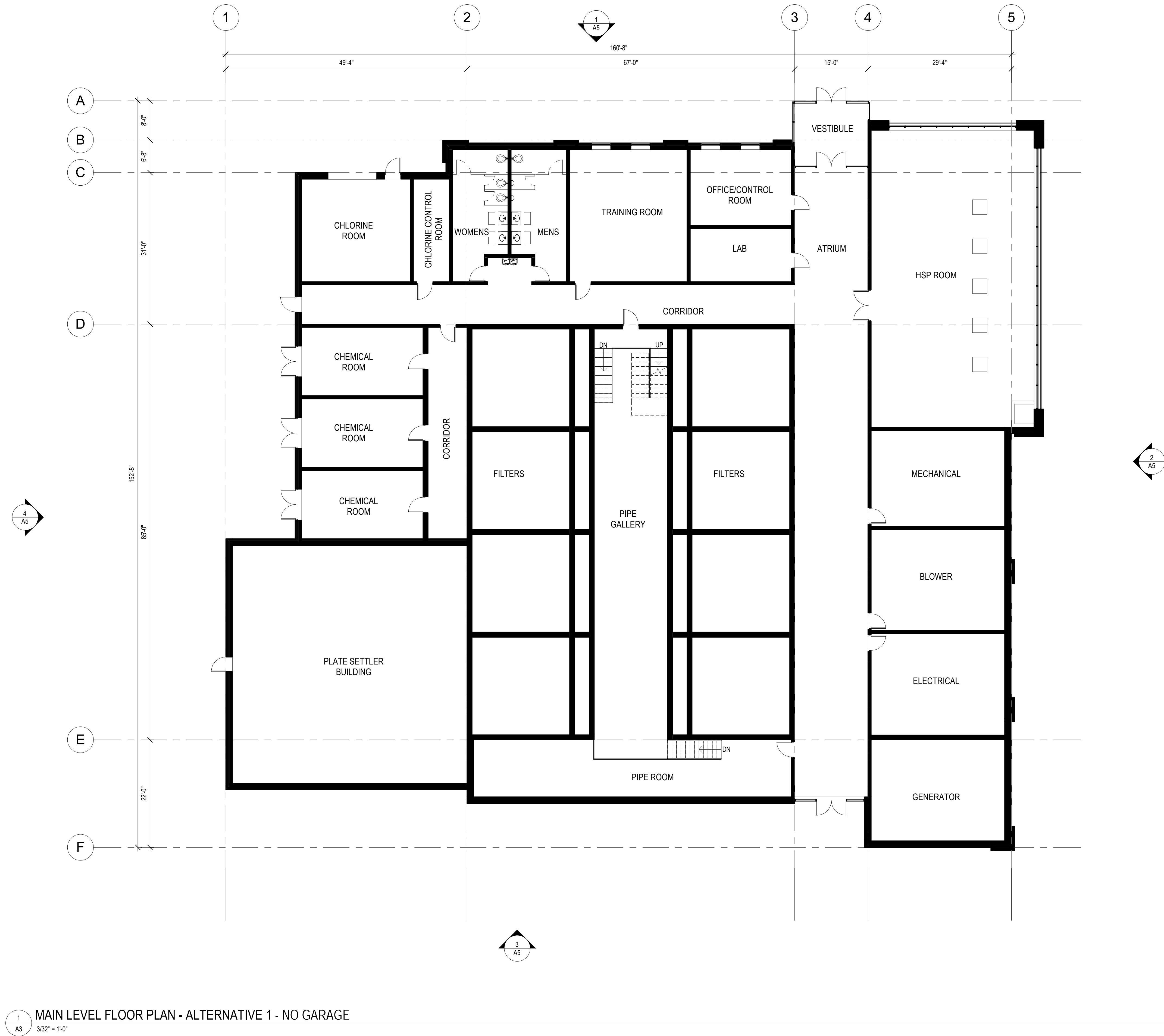

1
A3
MAIN LEVEL FLOOR PLAN - ALTERNATIVE 1 - NO GARAGE
3/32" = 1'-0"

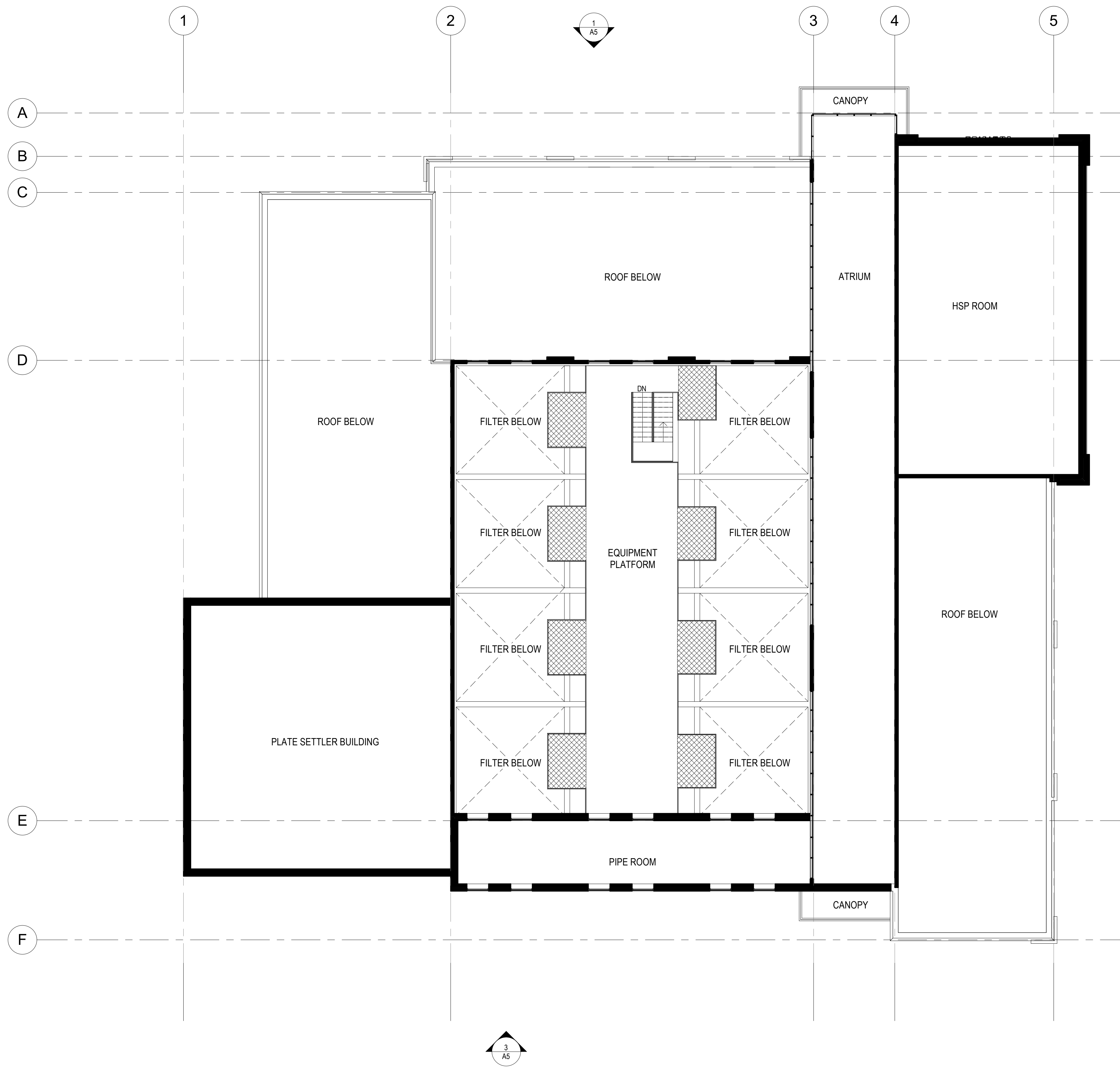

Appendix G

Pressure Filter Layouts

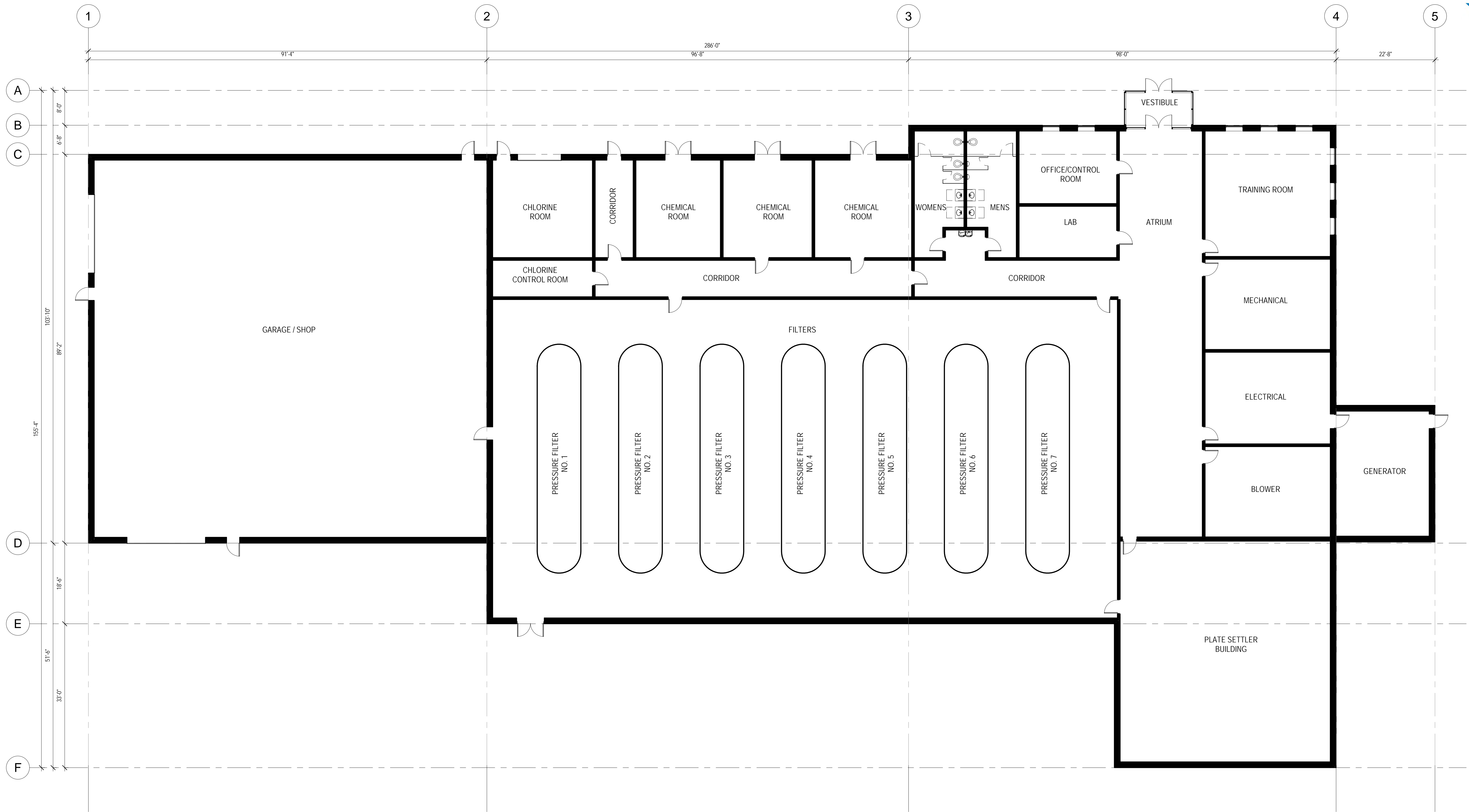

1 MAIN LEVEL FLOOR PLAN - ALTERNATIVE 2
 A2 3/32" = 1'-0"

Appendix H

Architectural Renderings



1
A1 EXTERIOR RENDERING - ALTERNATIVE 1



1 EXTERIOR RENDERING - ALTERNATIVE 1
A2

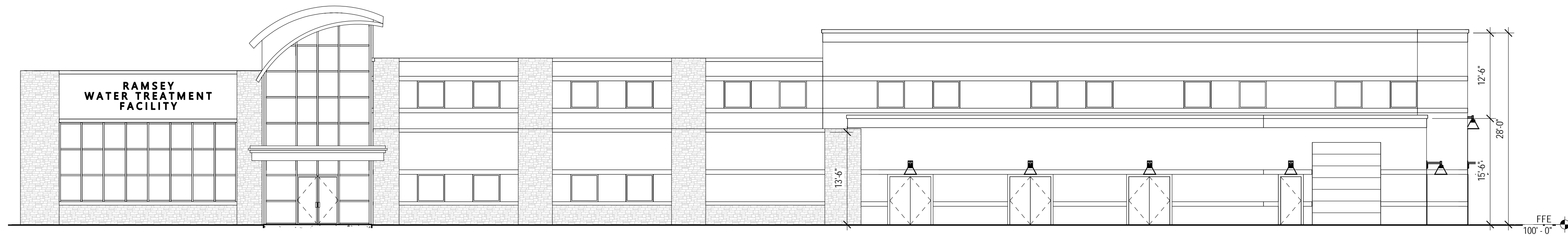

1
A5
EXTERIOR ELEVATION - FRONT - ALTERNATIVE 1
3/32" = 1'-0"

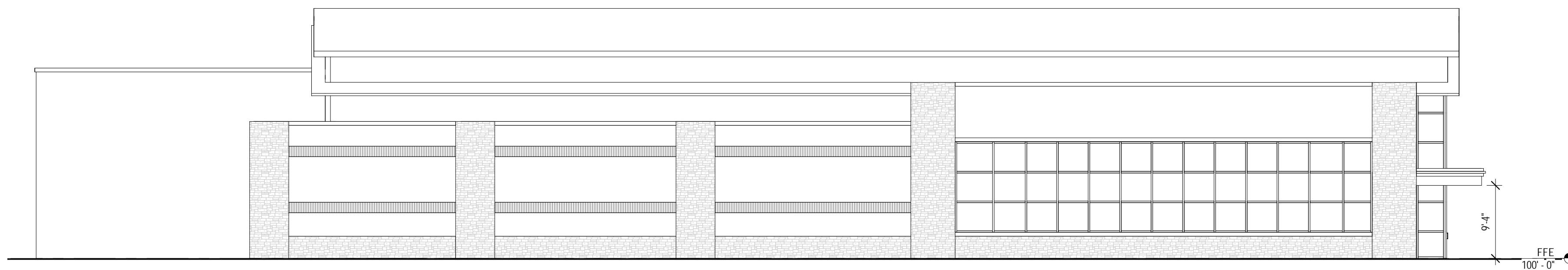

2
A5
EXTERIOR ELEVATION - LEFT - ALTERNATIVE 1
3/32" = 1'-0"

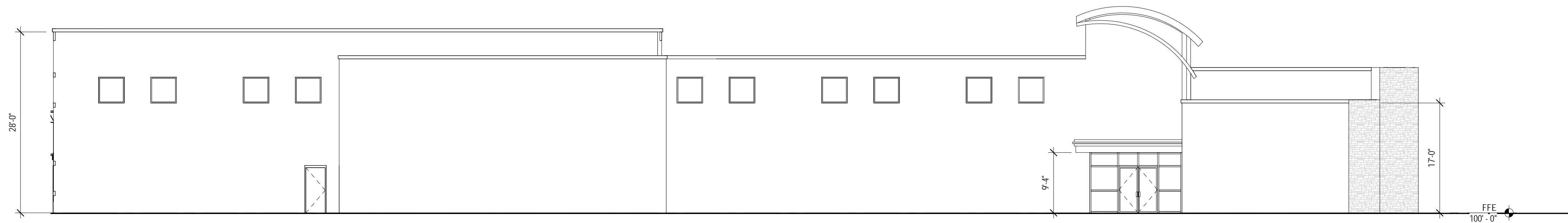

3
A5
EXTERIOR ELEVATION - BACK - ALTERNATIVE 1
3/32" = 1'-0"

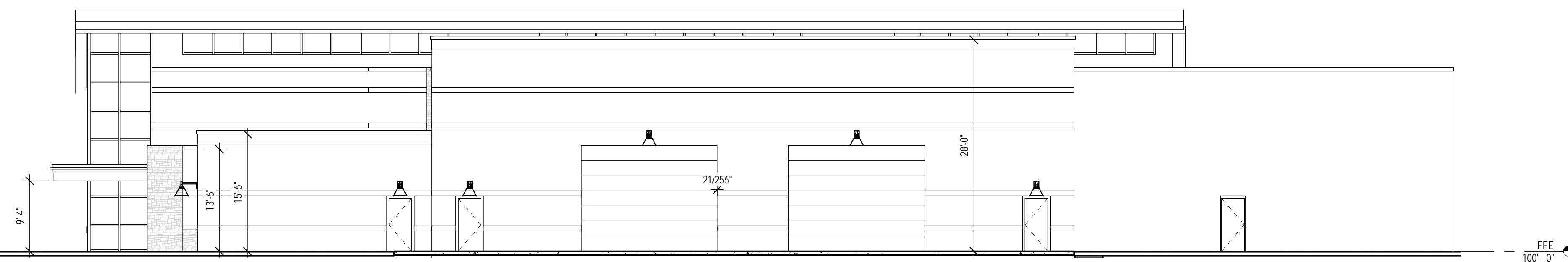

4
A5
EXTERIOR ELEVATION - RIGHT - ALTERNATIVE 1
3/32" = 1'-0"

Appendix I

Treatment Plant Sites and Raw Watermain

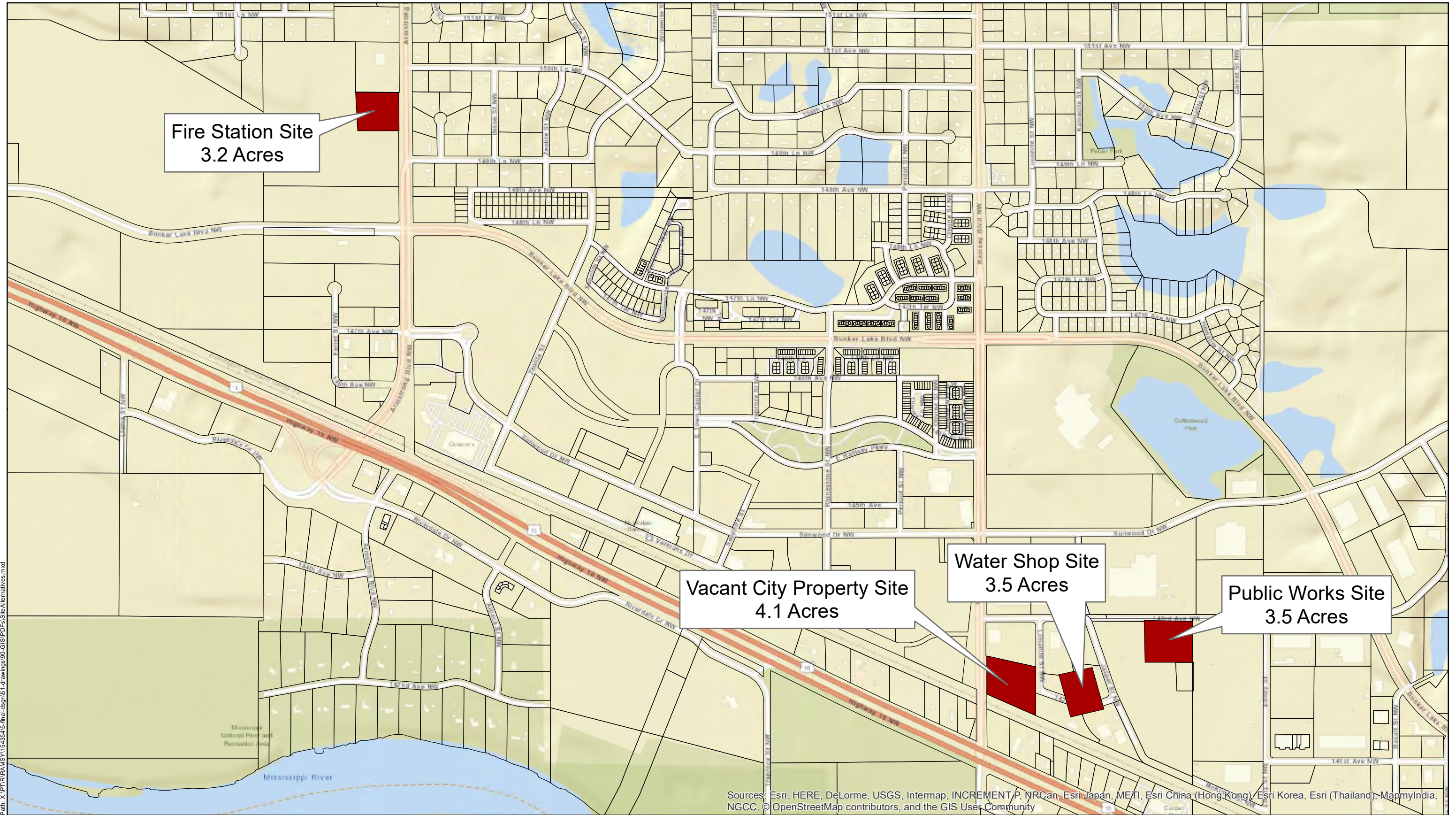

Path: X:\P\TR\RAMS\11543545-Plan-dsgn\1-Drawings\90-GIS\PDFs\SiteAlternatives.mxd

Sources: Esri, HERE, DeLorme, USGS, Intermap, INCREMENT P, NRCan, Esri Japan, METI, Esri China (Hong Kong), Esri Korea, Esri (Thailand), MapmyIndia, NGCC, © OpenStreetMap contributors, and the GIS User Community



3535 VADNAIS CENTER DR.
ST. PAUL, MN 55110
PHONE: (651) 490-2000
FAX: (888) 908-8166
TF: (800) 325-2055
www.sehinc.com

Project: XXXXX 000000
Print Date: 12/8/2020

WTP SITE ALTERNATIVES

Ramey, Minnesota

Figure
1

This map is neither a legally recorded map nor a survey map and is not intended to be used as one. This map is a compilation of records, information, and data gathered from various sources listed on this map and is to be used for reference purposes only. SEH does not warrant that the Geographic Information System (GIS) Data used to prepare this map are error free, and SEH does not represent that the GIS Data can be used for navigational, tracking, or any other purpose requiring exacting measurement of distance or direction or precision in the depiction of geographic features. The user of this map acknowledges that SEH shall not be liable for any damages which arise out of the user's access or use of data provided.

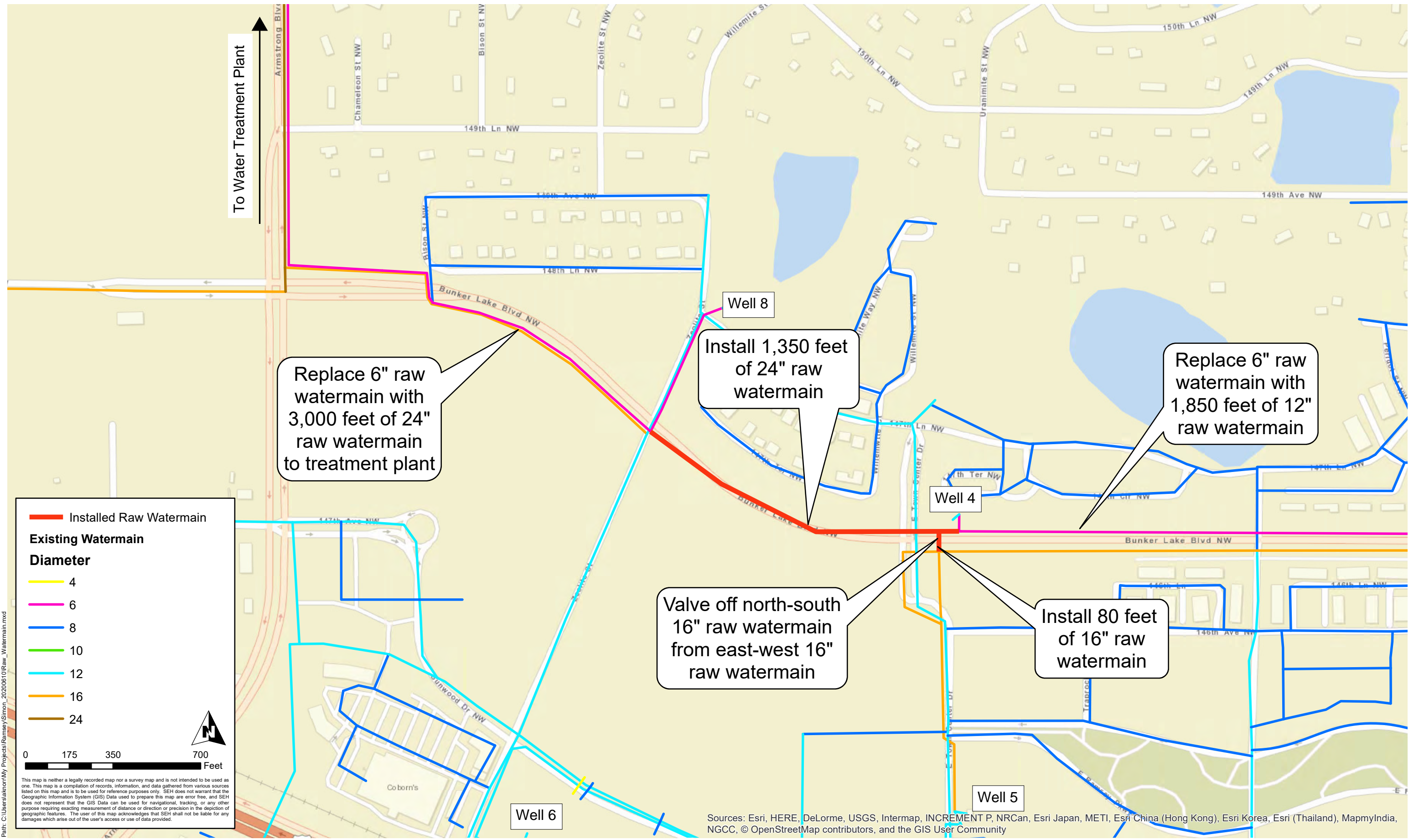

RAW WATERMAIN - FIRE STATION SITE
 Ramsey, Minnesota

| Figure 2
 Raw Watermain

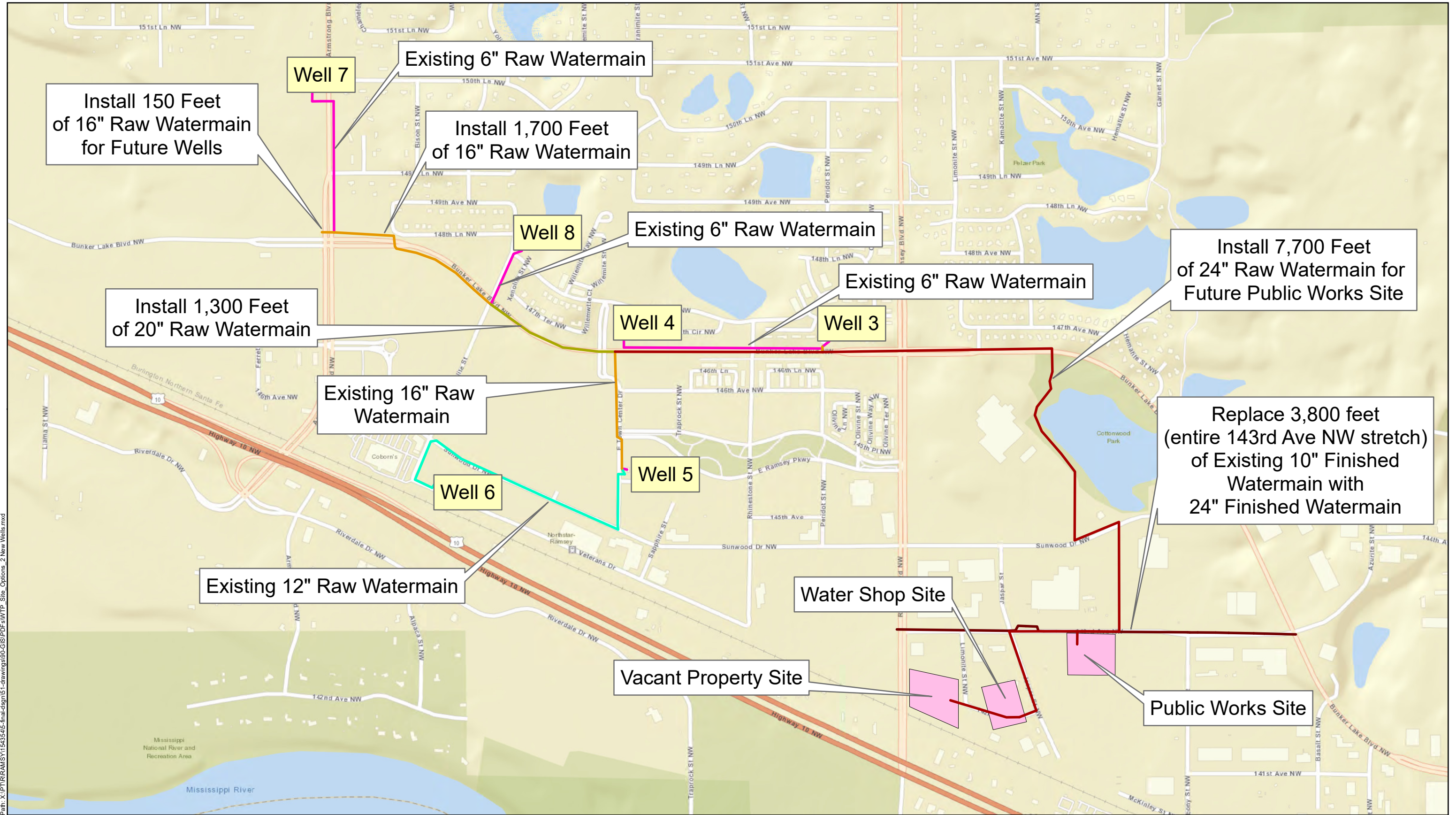

Path: X:\PTDR\RAMSY\154354\5-fmr-dwg\51-drawings\90-GIS\PDFs\WTP_Site_Options_2 New Wells.mxd



3535 VADNAIS CENTER DR.
ST. PAUL, MN 55110
PHONE: (651) 490-2000
FAX: (888) 908-8166
TF: (800) 325-2055
www.sehinc.com

Project: RAMSY 154354
Print Date: 3/1/2021

WATERMAIN - PUBLIC WORKS, WATER SHOP, OR VACANT PROPERTY SITES
Ramsey, Minnesota

Figure
3

This map is neither a legally recorded map nor a survey map and is not intended to be used as one. This map is a compilation of records, information, and data gathered from various sources listed on this map and is to be used for reference purposes only. SEH does not warrant that the Geographic Information System (GIS) Data used to prepare this map are error free, and SEH does not represent that the GIS Data can be used for navigational, tracking, or any other purpose requiring exacting measurement of distance or direction or precision in the depiction of geographic features. The user of this map acknowledges that SEH shall not be liable for any damages which arise out of the user's access or use of data provided.



WTP Alternatives - Fire Station Site
 Ramsey, Minnesota

Figure
 4



3535 VADNAIS CENTER DR.
 ST. PAUL, MN 55110
 PHONE: (651) 490-2000
 FAX: (888) 908-8166
 TF: (800) 325-2055
 www.sehinc.com

Project: XXXXX 000000
 Print Date: 11/30/2020

X:\Projects\150thLnNW-FireStation-WTP\150thLnNW-FireStation-WTP.dwg, 11/30/2020, 11:04:00 AM, 11/30/2020, 11:04:00 AM, 11/30/2020, 11:04:00 AM

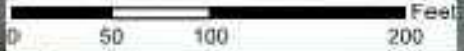

Source: Esri, DigitalGlobe, GeoEye, Earthstar Geographics, CNES/Airbus DS, USDA, USGS, AeroGRID, IGN, and the GIS User Community



3535 VADNAIS CENTER DR.
ST. PAUL, MN 55110
PHONE: (651) 490-2000
FAX: (888) 908-8166
TF: (800) 325-2055
www.sehinc.com

Project: XXXXX 000000
Print Date: 11/30/2020

WTP Alternatives - Water Shop Site Ramsey, Minnesota

Figure
6

Appendix J

Capital Cost Opinions



Project Name:	Ramsey WTP Feasibility Study
SEH Project No:	154354
Date:	March 3, 2021
Estimator:	MBJ
Description:	Alternative 1 - Concrete Gravity WTP

DIVISION 1 - GENERAL REQUIREMENTS	UNIT	EST. QUANTITY	UNIT PRICE	AMOUNT
GENERAL CONDITIONS	LUMP SUM	1	\$ 2,368,955.00	\$ 2,368,955.00
<i>SUBTOTAL DIVISION 0 AND 01</i>				<i>\$ 2,368,955.00</i>
DIVISION 3 - CONCRETE	UNIT	EST. QUANTITY	UNIT PRICE	AMOUNT
CAST IN PLACE CONCRETE - BACKWASH TANKS	CU YD	950	\$ 1,100.00	\$ 1,045,000.00
CAST IN PLACE CONCRETE - CLEARWELL	CU YD	1500	\$ 1,100.00	\$ 1,650,000.00
CAST IN PLACE CONCRETE - FILTERS	CU YD	1050	\$ 1,100.00	\$ 1,155,000.00
CAST IN PLACE CONCRETE - SLAB ON GRADE/FOOTINGS	CU YD	600	\$ 900.00	\$ 540,000.00
PRECAST STRUCTURAL CONCRETE - 8" PLANK	SQ FT	9800	\$ 25.00	\$ 245,000.00
PRECAST STRUCTURAL CONCRETE - 12" PLANK	SQ FT	12700	\$ 35.00	\$ 444,500.00
<i>SUBTOTAL DIVISION 3</i>				<i>\$ 5,079,500.00</i>
DIVISION 4 - MASONRY	UNIT	EST. QUANTITY	UNIT PRICE	AMOUNT
BRICK/STONE VENEER	SF	14600	\$ 40.00	\$ 584,000.00
CONCRETE UNIT MASONRY	SQ FT	34000	\$ 35.00	\$ 1,190,000.00
<i>SUBTOTAL DIVISION 4</i>				<i>\$ 1,774,000.00</i>
DIVISION 5 - METALS	UNIT	EST. QUANTITY	UNIT PRICE	AMOUNT
RAILING, ALUMINUM - WTP	LIN FT	1000	\$ 115.00	\$ 115,000.00
MISCELLANEOUS METALS - WTP	LUMP SUM	1	\$ 200,000.00	\$ 200,000.00
<i>SUBTOTAL DIVISION 5</i>				<i>\$ 315,000.00</i>
DIVISION 6 - WOOD, PLASTICS & COMPOSITES	UNIT	EST. QUANTITY	UNIT PRICE	AMOUNT
PLASTIC FABRICATIONS - FRP LADDERS	EACH	14	\$ 3,000.00	\$ 42,000.00
ROUGH CARPENTRY	LUMP SUM	1	\$ 40,000.00	\$ 40,000.00
GYPSUM DRYWALL	SF	8000	\$ 4.00	\$ 32,000.00
<i>SUBTOTAL DIVISION 6</i>				<i>\$ 114,000.00</i>
DIVISION 7 - THERMAL & MOISTURE PROTECTION	UNIT	EST. QUANTITY	UNIT PRICE	AMOUNT
JOINT SEALANTS	LUMP SUM	1	\$ 40,000.00	\$ 40,000.00
WATERPROOFING/AIR BARRIER	LUMP SUM	1	\$ 200,000.00	\$ 200,000.00
MEMBRANE ROOFING AND INSULATION	SF	21600	\$ 25.00	\$ 540,000.00
<i>SUBTOTAL DIVISION 7</i>				<i>\$ 780,000.00</i>
DIVISION 8 - OPENINGS	UNIT	EST. QUANTITY	UNIT PRICE	AMOUNT
FRP DOORS (SINGLE LEAF)	EACH	30	\$ 3,300.00	\$ 99,000.00
FRP DOORS (DOUBLE LEAF)	EACH	3	\$ 6,600.00	\$ 19,800.00
OVERHEAD DOOR - CHLORINE ROOM	EACH	1	\$ 17,500.00	\$ 17,500.00
ALUMINUM STOREFRONT	LUMP SUM	1	\$ 260,000.00	\$ 260,000.00
WINDOWS	EACH	28	\$ 3,000.00	\$ 84,000.00
FIRE RATED ALUM. FRAME AND GLASS	LUMP SUM	1	\$ 5,000.00	\$ 5,000.00
TANK HATCHES	UNIT	10	\$ 3,000.00	\$ 30,000.00
LOUVERS	LUMP SUM	1	\$ 20,000.00	\$ 20,000.00
<i>SUBTOTAL DIVISION 8</i>				<i>\$ 535,300.00</i>
DIVISION 9 - FINISHES	UNIT	EST. QUANTITY	UNIT PRICE	AMOUNT
ACOUSTICAL CEILING	SF	2000	\$ 6.00	\$ 12,000.00
FLOORING - TILE AND CARPET	LUMP SUM	1	\$ 170,000.00	\$ 170,000.00
WALL & CEILING PAINTING	SF	69000	\$ 3.00	\$ 207,000.00
EQUIPMENT/PROCESS PIPING PAINTING	LUMP SUM	1	\$ 150,000.00	\$ 150,000.00
<i>SUBTOTAL DIVISION 9</i>				<i>\$ 539,000.00</i>
DIVISION 10 - SPECIALTIES	UNIT	EST. QUANTITY	UNIT PRICE	AMOUNT
TOILET ACCESSORIES	LUMP SUM	2	\$ 2,500.00	\$ 5,000.00
FIRE EXTINGUISHERS	EACH	10	\$ 250.00	\$ 2,500.00
INTERIOR PANEL SIGNAGE	LUMP SUM	1	\$ 3,000.00	\$ 3,000.00
<i>SUBTOTAL DIVISION 10</i>				<i>\$ 10,500.00</i>
DIVISION 12 - FURNISHINGS	UNIT	EST. QUANTITY	UNIT PRICE	AMOUNT
METAL CASEWORK - BASE AND UPPERS	LUMP SUM	1	\$ 35,000.00	\$ 35,000.00

FURNITURE	LUMP SUM	1	\$ 30,000.00	\$ 30,000.00
<i>SUBTOTAL DIVISION 12</i>				
				\$ 65,000.00
DIVISION 21 - FIRE SUPPRESSION	UNIT	EST. QUANTITY	UNIT PRICE	AMOUNT
FIRE PROTECTION SYSTEM (WET)	LUMP SUM	1	\$ 75,000.00	\$ 75,000.00
<i>SUBTOTAL DIVISION 21</i>				
				\$ 75,000.00
DIVISION 22 - PLUMBING	UNIT	EST. QUANTITY	UNIT PRICE	AMOUNT
PLUMBING	LUMP SUM	1	\$ 430,000.00	\$ 430,000.00
<i>SUBTOTAL DIVISION 22</i>				
				\$ 430,000.00
DIVISION 23 - HVAC	UNIT	EST. QUANTITY	UNIT PRICE	AMOUNT
HVAC	LUMP SUM	1	\$ 910,000.00	\$ 910,000.00
<i>SUBTOTAL DIVISION 23</i>				
				\$ 910,000.00
DIVISION 26 - ELECTRICAL	UNIT	EST. QUANTITY	UNIT PRICE	AMOUNT
ELECTRICAL	LUMP SUM	1	\$ 2,900,000.00	\$ 2,900,000.00
<i>SUBTOTAL DIVISION 26</i>				
				\$ 2,900,000.00
DIVISION 31 - EARTHWORK	UNIT	EST. QUANTITY	UNIT PRICE	AMOUNT
CLEAR AND GRUB	ACRE	2.00	\$ 10,000.00	\$ 20,000.00
BUILDING EXCAVATION	CU YD	8500	\$ 15.00	\$ 127,500.00
CLEARWELL EXCAVATION	CU YD	8000	\$ 15.00	\$ 120,000.00
BACKWASH TANK	CU YD	7500	\$ 15.00	\$ 112,500.00
HAULING EARTH	CU YD	12000	\$ 8.00	\$ 96,000.00
BACKFILLING & COMPACTING	CU YD	15000	\$ 25.00	\$ 375,000.00
EROSION CONTROL	EACH	1	\$ 30,000.00	\$ 30,000.00
<i>SUBTOTAL DIVISION 31</i>				
				\$ 881,000.00
DIVISION 32 - EXTERIOR IMPROVEMENTS	UNIT	EST. QUANTITY	UNIT PRICE	AMOUNT
AGGREGATE BASE (CL 5)	CU YD	1500	\$ 40.00	\$ 60,000.00
BITUMINOUS PAVEMENT	TON	1300	\$ 100.00	\$ 130,000.00
4" CONCRETE SIDEWALK	SQ FT	4000	\$ 10.00	\$ 40,000.00
TOPSOIL BORROW (3" DEPTH)	CU YD	500	\$ 25.00	\$ 12,500.00
LANDSCAPING	LUMP SUM	1.0	\$ 40,000.00	\$ 40,000.00
CHAIN LIKE FENCE	LIN FT	1200	\$ 90.00	\$ 108,000.00
<i>SUBTOTAL DIVISION 32</i>				
				\$ 390,500.00
DIVISION 33 - UTILITIES	UNIT	EST. QUANTITY	UNIT PRICE	AMOUNT
24" RAW WATERMAIN	LIN FT	7300	\$ 230	\$ 1,679,000.00
24" ROAD CROSSING (RAMSEY BLVD and BUNKER LAKE BLVD) - JACKED CASING	LIN FT	400	\$ 525	\$ 210,000.00
24" FINISHED WATERMAIN	LIN FT	3800	\$ 230	\$ 874,000.00
20" RAW WATERMAIN	LIN FT	1300	\$ 185	\$ 240,500.00
16" RAW WATERMAIN	LIN FT	1750	\$ 165	\$ 288,750.00
16" RAW WATERMAIN (ARMSTRONG BLVD) - JACKED CASING	LIN FT	100	\$ 425	\$ 42,500.00
WELL 8 METER VAULT	LUMP SUM	1	\$ 90,000	\$ 90,000.00
HYDRANTS	EACH	4	\$ 10,000	\$ 40,000.00
SITE PROCESS PIPING	LUMP SUM	1	\$ 450,000	\$ 450,000.00
SANITARY SEWER	LUMP SUM	1	\$ 50,000.00	\$ 50,000.00
STORM SEWER	LUMP SUM	1	\$ 40,000.00	\$ 40,000.00
<i>SUBTOTAL DIVISION 33</i>				
				\$ 4,004,750.00
DIVISION 40 - PROCESS INTERCONNECTIONS	UNIT	EST. QUANTITY	UNIT PRICE	AMOUNT
PROCESS PIPING AND VALVES	LUMP SUM	1	\$ 2,700,000.00	\$ 2,700,000.00
<i>SUBTOTAL DIVISION 40</i>				
				\$ 2,700,000.00
DIVISION 43 - PROCESS GAS & LIQUID HANDLING, PURIFICATION & STORAGE EQUIPMENT	UNIT	EST. QUANTITY	UNIT PRICE	AMOUNT
HIGH SERVICE VERTICAL TURBINE PUMPS	EACH	5	\$ 50,000.00	\$ 250,000.00
BACKWASH VERTICAL TURBINE PUMP	EACH	1	\$ 50,000.00	\$ 50,000.00
MAGNETIC FLOW METERS	LUMP SUM	1	\$ 80,000.00	\$ 80,000.00
<i>SUBTOTAL DIVISION 43</i>				
				\$ 380,000.00
DIVISION 44 - POLLUTION & CONTROL EQUIPMENT	UNIT	EST. QUANTITY	UNIT PRICE	AMOUNT
COMPRESSED AIR SYSTEM	LUMP SUM	1	\$ 16,000.00	\$ 16,000.00
AIR SCOUR BLOWER	EACH	1	\$ 25,000.00	\$ 25,000.00
GRAVITY FILTER EQUIPMENT	LUMP SUM	1	\$ 900,000.00	\$ 900,000.00
LAMELLA PLATE SETTLERS	EACH	2	\$ 350,000.00	\$ 700,000.00
GAS CHLORINATION SYSTEM	LUMP SUM	1	\$ 50,000.00	\$ 50,000.00
POLYPHOSPHATE FEED EQUIPMENT	LUMP SUM	1	\$ 25,000.00	\$ 25,000.00

SODIUM PERMANGANATE FEED EQUIPMENT	LUMP SUM	1	\$ 40,000.00	\$ 40,000.00
CHEMICAL FEED PIPING	LUMP SUM	1	\$ 50,000.00	\$ 50,000.00
				\$ 1,806,000.00
SUBTOTAL CONSTRUCTION				\$ 26,060,000.00
CONTINGENCY			10%	\$ 2,606,000.00
TOTAL CONSTRUCTION				\$ 28,670,000.00



Project Name: **Ramsey WTP Feasibility Study**
 SEH Project No: **154354**
 Date: **March 4, 2021**
 Estimator: **MBJ**
 Description: **Alternative 2 - Pressure Filter WTP**

DIVISION 1 - GENERAL REQUIREMENTS	UNIT	EST. QUANTITY	UNIT PRICE	AMOUNT
GENERAL CONDITIONS	LUMP SUM	1	\$ 2,251,435.00	\$ 2,251,435.00
<i>SUBTOTAL DIVISION 0 AND 01</i>				<i>\$ 2,251,435.00</i>
DIVISION 3 - CONCRETE	UNIT	EST. QUANTITY	UNIT PRICE	AMOUNT
CAST IN PLACE CONCRETE - BACKWASH TANKS	CU YD	950	\$ 1,100.00	\$ 1,045,000.00
CAST IN PLACE CONCRETE - SLAB ON GRADE/FOOTINGS	CU YD	1600	\$ 1,100.00	\$ 1,760,000.00
PRECAST STRUCTURAL CONCRETE - 8" PLANK	SQ FT	8500	\$ 25.00	\$ 212,500.00
PRECAST STRUCTURAL CONCRETE - 12" PLANK	SQ FT	10300	\$ 35.00	\$ 360,500.00
<i>SUBTOTAL DIVISION 3</i>				<i>\$ 3,378,000.00</i>
DIVISION 4 - MASONRY	UNIT	EST. QUANTITY	UNIT PRICE	AMOUNT
BRICK/STONE VENEER	SF	12600	\$ 40.00	\$ 504,000.00
CONCRETE UNIT MASONRY	SQ FT	27000	\$ 35.00	\$ 945,000.00
<i>SUBTOTAL DIVISION 4</i>				<i>\$ 1,449,000.00</i>
DIVISION 5 - METALS	UNIT	EST. QUANTITY	UNIT PRICE	AMOUNT
MISCELLANEOUS METALS - WTP	LUMP SUM	1	\$ 150,000.00	\$ 150,000.00
<i>SUBTOTAL DIVISION 5</i>				<i>\$ 150,000.00</i>
DIVISION 6 - WOOD, PLASTICS & COMPOSITES	UNIT	EST. QUANTITY	UNIT PRICE	AMOUNT
PLASTIC FABRICATIONS - FRP LADDERS	EACH	6	\$ 3,000.00	\$ 18,000.00
ROUGH CARPENTRY	LUMP SUM	1	\$ 30,000.00	\$ 30,000.00
GYPSUM DRYWALL	SF	8000	\$ 4.00	\$ 32,000.00
<i>SUBTOTAL DIVISION 6</i>				<i>\$ 80,000.00</i>
DIVISION 7 - THERMAL & MOISTURE PROTECTION	UNIT	EST. QUANTITY	UNIT PRICE	AMOUNT
JOINT SEALANTS	LUMP SUM	1	\$ 40,000.00	\$ 40,000.00
WATERPROOFING/AIR BARRIER	LUMP SUM	1	\$ 200,000.00	\$ 200,000.00
MEMBRANE ROOFING AND INSULATION	SF	22200	\$ 25.00	\$ 555,000.00
<i>SUBTOTAL DIVISION 7</i>				<i>\$ 795,000.00</i>
DIVISION 8 - OPENINGS	UNIT	EST. QUANTITY	UNIT PRICE	AMOUNT
FRP DOORS (SINGLE LEAF)	EACH	26	\$ 3,300.00	\$ 85,800.00
FRP DOORS (DOUBLE LEAF)	EACH	3	\$ 6,600.00	\$ 19,800.00
OVERHEAD DOOR - CHLORINE ROOM	EACH	1	\$ 17,500.00	\$ 17,500.00
ALUMINUM STOREFRONT	LUMP SUM	1	\$ 200,000.00	\$ 200,000.00
WINDOWS	EACH	28	\$ 3,000.00	\$ 84,000.00
FIRE RATED ALUM. FRAME AND GLASS	LUMP SUM	1	\$ 5,000.00	\$ 5,000.00
TANK HATCHES	UNIT	6	\$ 3,000.00	\$ 18,000.00
LOUVERS	LUMP SUM	1	\$ 20,000.00	\$ 20,000.00
<i>SUBTOTAL DIVISION 8</i>				<i>\$ 450,100.00</i>
DIVISION 9 - FINISHES	UNIT	EST. QUANTITY	UNIT PRICE	AMOUNT
ACOUSTICAL CEILING	SF	2000	\$ 6.00	\$ 12,000.00
FLOORING - TILE AND CARPET	LUMP SUM	1	\$ 150,000.00	\$ 150,000.00
WALL & CEILING PAINTING	SF	48000	\$ 3.00	\$ 144,000.00
EQUIPMENT/PROCESS PIPING PAINTING	LUMP SUM	1	\$ 275,000.00	\$ 275,000.00
<i>SUBTOTAL DIVISION 9</i>				<i>\$ 581,000.00</i>
DIVISION 10 - SPECIALTIES	UNIT	EST. QUANTITY	UNIT PRICE	AMOUNT
TOILET ACCESSORIES	LUMP SUM	2	\$ 2,500.00	\$ 5,000.00
FIRE EXTINGUISHERS	EACH	10	\$ 250.00	\$ 2,500.00
INTERIOR PANEL SIGNAGE	LUMP SUM	1	\$ 3,000.00	\$ 3,000.00
<i>SUBTOTAL DIVISION 10</i>				<i>\$ 10,500.00</i>
DIVISION 12 - FURNISHINGS	UNIT	EST. QUANTITY	UNIT PRICE	AMOUNT
METAL CASEWORK - BASE AND UPPERS	LUMP SUM	1	\$ 35,000.00	\$ 35,000.00
FURNITURE	LUMP SUM	1	\$ 30,000.00	\$ 30,000.00
<i>SUBTOTAL DIVISION 12</i>				<i>\$ 65,000.00</i>
DIVISION 21 - FIRE SUPPRESSION	UNIT	EST. QUANTITY	UNIT PRICE	AMOUNT

FIRE PROTECTION SYSTEM (WET)	LUMP SUM	1	\$ 75,000.00	\$ 75,000.00
<i>SUBTOTAL DIVISION 21</i>				
				\$ 75,000.00
DIVISION 22 - PLUMBING	UNIT	EST. QUANTITY	UNIT PRICE	AMOUNT
PLUMBING	LUMP SUM	1	\$ 430,000.00	\$ 430,000.00
<i>SUBTOTAL DIVISION 22</i>				
				\$ 430,000.00
DIVISION 23 - HVAC	UNIT	EST. QUANTITY	UNIT PRICE	AMOUNT
HVAC	LUMP SUM	1	\$ 835,000.00	\$ 835,000.00
<i>SUBTOTAL DIVISION 23</i>				
				\$ 835,000.00
DIVISION 26 - ELECTRICAL	UNIT	EST. QUANTITY	UNIT PRICE	AMOUNT
ELECTRICAL	LUMP SUM	1	\$ 2,200,000.00	\$ 2,200,000.00
<i>SUBTOTAL DIVISION 26</i>				
				\$ 2,200,000.00
DIVISION 31 - EARTHWORK	UNIT	EST. QUANTITY	UNIT PRICE	AMOUNT
CLEAR AND GRUB	ACRE	2.00	\$ 10,000.00	\$ 20,000.00
BUILDING EXCAVATION	CU YD	4000	\$ 15.00	\$ 60,000.00
BACKWASH TANK	CU YD	7500	\$ 15.00	\$ 112,500.00
HAULING EARTH	CU YD	4000	\$ 8.00	\$ 32,000.00
BACKFILLING & COMPACTING	CU YD	4000	\$ 25.00	\$ 100,000.00
EROSION CONTROL	EACH	1	\$ 30,000.00	\$ 30,000.00
<i>SUBTOTAL DIVISION 31</i>				
				\$ 354,500.00
DIVISION 32 - EXTERIOR IMPROVEMENTS	UNIT	EST. QUANTITY	UNIT PRICE	AMOUNT
AGGREGATE BASE (CL 5)	CU YD	1500	\$ 40.00	\$ 60,000.00
BITUMINOUS PAVEMENT	TON	1300	\$ 100.00	\$ 130,000.00
4" CONCRETE SIDEWALK	SQ FT	4000	\$ 10.00	\$ 40,000.00
TOPSOIL BORROW (3" DEPTH)	CU YD	500	\$ 25.00	\$ 12,500.00
LANDSCAPING	LUMP SUM	1.0	\$ 40,000.00	\$ 40,000.00
CHAIN LIKE FENCE	LIN FT	1200	\$ 90.00	\$ 108,000.00
<i>SUBTOTAL DIVISION 32</i>				
				\$ 390,500.00
DIVISION 33 - UTILITIES	UNIT	EST. QUANTITY	UNIT PRICE	AMOUNT
24" RAW WATERMAIN	LIN FT	7300	\$ 230	\$ 1,679,000.00
24" ROAD CROSSING (RAMSEY BLVD and BUNKER LAKE BLVD) - JACKED CASING	LIN FT	400	\$ 525	\$ 210,000.00
24" FINISHED WATERMAIN	LIN FT	3800	\$ 230	\$ 874,000.00
20" RAW WATERMAIN	LIN FT	1300	\$ 185	\$ 240,500.00
16" RAW WATERMAIN	LIN FT	1750	\$ 165	\$ 288,750.00
16" RAW WATERMAIN (ARMSTRONG BLVD) - JACKED CASING	LIN FT	100	\$ 425	\$ 42,500.00
WELL 8 METER VAULT	LUMP SUM	1	\$ 90,000	\$ 90,000.00
HYDRANTS	EACH	4	\$ 10,000.00	\$ 40,000.00
SITE PROCESS PIPING	LUMP SUM	1	\$ 250,000.00	\$ 250,000.00
SANITARY SEWER	LUMP SUM	1	\$ 50,000.00	\$ 50,000.00
STORM SEWER	LUMP SUM	1	\$ 40,000.00	\$ 40,000.00
<i>SUBTOTAL DIVISION 33</i>				
				\$ 3,804,750.00
DIVISION 40 - PROCESS INTERCONNECTIONS	UNIT	EST. QUANTITY	UNIT PRICE	AMOUNT
PROCESS PIPING AND VALVES	LUMP SUM	1	\$ 2,950,000.00	\$ 2,950,000.00
<i>SUBTOTAL DIVISION 40</i>				
				\$ 2,950,000.00
DIVISION 43 - PROCESS GAS & LIQUID HANDLING, PURIFICATION & STORAGE EQUIPMENT	UNIT	EST. QUANTITY	UNIT PRICE	AMOUNT
MAGNETIC FLOW METERS	LUMP SUM	1	\$ 110,000.00	\$ 110,000.00
<i>SUBTOTAL DIVISION 43</i>				
				\$ 110,000.00
DIVISION 44 - POLLUTION & CONTROL EQUIPMENT	UNIT	EST. QUANTITY	UNIT PRICE	AMOUNT
COMPRESSED AIR SYSTEM	LUMP SUM	1	\$ 16,000.00	\$ 16,000.00
AIR SCOUR BLOWER	EACH	1	\$ 25,000.00	\$ 25,000.00
PRESSURE FILTER EQUIPMENT	LUMP SUM	1	\$ 3,500,000.00	\$ 3,500,000.00
LAMELLA PLATE SETTLERS	EACH	2	\$ 350,000.00	\$ 700,000.00
GAS CHLORINATION SYSTEM	LUMP SUM	1	\$ 50,000.00	\$ 50,000.00
POLYPHOSPHATE FEED EQUIPMENT	LUMP SUM	1	\$ 25,000.00	\$ 25,000.00
SODIUM PERMANGANATE FEED EQUIPMENT	LUMP SUM	1	\$ 40,000.00	\$ 40,000.00
CHEMICAL FEED PIPING	LUMP SUM	1	\$ 50,000.00	\$ 50,000.00
<i>SUBTOTAL DIVISION 44</i>				
				\$ 4,406,000.00
TOTAL CONSTRUCTION				\$ 24,766,000.00
CONTINGENCY			10%	\$ 2,477,000.00
TOTAL PROJECT				\$ 27,240,000.00

Appendix K

Life Cycle Cost Opinions

**50 Year Life Cycle Cost Estimate
Alternative 1
Concrete Gravity Filter Water Treatment Plant, Ramsey, Minnesota**

Division	Item	Capital Cost		Annual Repair Costs	Capital Cost plus Admin, Eng, etc.	Useful Life	First Replacement PW	Second Replacement PW	Third Replacement PW	Salvage Value	Salvage Value PW	Total Materials & Equipment Replacement PW
1	General	\$2,368,955	9.09%	\$0	\$2,944,962	50	\$0.00	\$0.00	\$0.00	\$0.00	\$0.00	\$0.00
3	Concrete	\$5,079,500	19.49%	\$0	\$6,314,570	75	\$0.00	\$0.00	\$0.00	\$2,104,856.76	(\$2,104,856.76)	(\$2,104,856.76)
4	Masonry	\$1,774,000	6.81%	\$0	\$2,205,345	50	\$0.00	\$0.00	\$0.00	\$0.00	\$0.00	\$0.00
5	Metals	\$315,000	1.21%	\$0	\$391,592	50	\$0.00	\$0.00	\$0.00	\$0.00	\$0.00	\$0.00
6	Wood & Plastics	\$114,000	0.44%	\$0	\$141,719	50	\$0.00	\$0.00	\$0.00	\$0.00	\$0.00	\$0.00
7	Thermal & Moisture	\$780,000	2.99%	\$5,000	\$969,655	30	\$969,655.44	\$0.00	\$0.00	\$323,218.48	(\$323,218.48)	\$646,436.96
8	Doors & Windows	\$535,300	2.05%	\$10,000	\$665,457	25	\$665,457.12	\$0.00	\$0.00	\$0.00	\$0.00	\$665,457.12
9	Finishes	\$539,000	2.07%	\$5,000	\$670,057	25	\$670,056.77	\$0.00	\$0.00	\$0.00	\$0.00	\$670,056.77
10	Specialties	\$10,500	0.04%	\$0	\$13,053	30	\$13,053.05	\$0.00	\$0.00	\$4,351.02	(\$4,351.02)	\$8,702.04
12	Furnishings	\$65,000	0.25%	\$0	\$80,805	25	\$80,804.62	\$0.00	\$0.00	\$0.00	\$0.00	\$80,804.62
21	Fire Suppression	\$75,000	0.29%	\$0	\$93,236	25	\$93,236.10	\$0.00	\$0.00	\$0.00	\$0.00	\$93,236.10
22	Plumbing	\$430,000	1.65%	\$0	\$534,554	40	\$534,553.64	\$0.00	\$0.00	\$400,915.23	(\$400,915.23)	\$133,638.41
23	HVAC	\$910,000	3.49%	\$20,000	\$1,131,265	25	\$1,131,264.68	\$0.00	\$0.00	\$0.00	\$0.00	\$1,131,264.68
26	Electrical	\$2,900,000	11.13%	\$30,000	\$3,605,129	25	\$3,605,129.20	\$0.00	\$0.00	\$0.00	\$0.00	\$3,605,129.20
31	Earthwork	\$881,000	3.38%	\$0	\$1,095,213	50	\$0.00	\$0.00	\$0.00	\$0.00	\$0.00	\$0.00
32	Exterior Improvements	\$390,500	1.50%	\$0	\$485,449	40	\$485,449.29	\$0.00	\$0.00	\$364,086.97	(\$364,086.97)	\$121,362.32
33	Utilities	\$4,004,750	15.37%	\$0	\$4,978,497	50	\$0.00	\$0.00	\$0.00	\$0.00	\$0.00	\$0.00
40	Process Piping	\$2,700,000	10.36%	\$10,000	\$3,366,500	25	\$3,366,499.60	\$0.00	\$0.00	\$0.00	\$0.00	\$3,366,499.60
43	Process Pumps/Meters	\$380,000	1.46%	\$20,000	\$472,396	30	\$472,396.24	\$0.00	\$0.00	\$157,465.41	(\$157,465.41)	\$314,930.83
44	Process Equipment	\$1,806,000	6.93%	\$20,000	\$2,245,125	35	\$2,245,125.29	\$0.00	\$0.00	\$1,282,928.74	(\$1,282,928.74)	\$962,196.55
TOTALS		\$26,060,000	99.99%	\$120,000	\$32,400,000							\$9,694,858

50 Year Life Cycle (Present Worth)

20 year Annual Costs

Inflation = 2.75%
Interest = 2.00%
Financing Years= 20

Capital Project Costs	\$32,400,000	Loan Payment	\$1,981,478
Equipment Replacement	\$9,694,858	Annual Equipment Replacement	\$308,522
Labor	\$6,488,398	Labor	\$110,000
Gas	\$1,179,709	Gas	\$20,000
Chemicals	\$6,488,398	Chemicals	\$110,000
Insurance	\$1,769,563	Insurance	\$30,000
Electricity	\$6,783,325	Electricity	\$115,000
Equip. Repair	\$7,078,253	Equip. Repair	\$120,000
		3 mgd, 2 mg/L Cl @ \$1/lb, 1 mg/L NaMnO4 @ \$10/gal, 2 mg/L phosphate @ \$5/gal	
		Assumes 120kW 24/7 at \$0.10 per kWh	
TOTAL PW	\$71,880,000	TOTAL ANNUAL COST:	\$2,795,000

**50 Year Life Cycle Cost Estimate
Alternative 2
Pressure Filter Water Treatment Plant, Ramsey, Minnesota**

Division	Item	Capital Cost		Annual Repair Costs	Capital Cost plus Contingency, Admin, Eng, etc.	Useful Life	First Replacement PW	Second Replacement PW	Third Replacement PW	Salvage Value	Salvage Value PW	Total Materials & Equipment Replacement PW
1	General	\$2,251,435	9.09%	\$0	\$2,798,534	50	\$0.00	\$0.00	\$0.00	\$0.00	\$0.00	\$0.00
3	Concrete	\$3,378,000	13.64%	\$0	\$4,198,854	75	\$0.00	\$0.00	\$0.00	\$1,399,618.00	(\$1,399,618.00)	(\$1,399,618.00)
4	Masonry	\$1,449,000	5.85%	\$0	\$1,801,107	50	\$0.00	\$0.00	\$0.00	\$0.00	\$0.00	\$0.00
5	Metals	\$150,000	0.61%	\$0	\$186,450	50	\$0.00	\$0.00	\$0.00	\$0.00	\$0.00	\$0.00
6	Wood & Plastics	\$80,000	0.32%	\$0	\$99,440	50	\$0.00	\$0.00	\$0.00	\$0.00	\$0.00	\$0.00
7	Thermal & Moisture	\$795,000	3.21%	\$5,000	\$988,185	30	\$988,185.00	\$0.00	\$0.00	\$329,395.00	(\$329,395.00)	\$658,790.00
8	Doors & Windows	\$450,100	1.82%	\$10,000	\$559,474	25	\$559,474.30	\$0.00	\$0.00	\$0.00	\$0.00	\$559,474.30
9	Finishes	\$581,000	2.35%	\$10,000	\$722,183	25	\$722,183.00	\$0.00	\$0.00	\$0.00	\$0.00	\$722,183.00
10	Specialties	\$10,500	0.04%	\$0	\$13,052	30	\$13,051.50	\$0.00	\$0.00	\$4,350.50	(\$4,350.50)	\$8,701.00
12	Furnishings	\$65,000	0.26%	\$0	\$80,795	25	\$80,795.00	\$0.00	\$0.00	\$0.00	\$0.00	\$80,795.00
21	Fire Suppression	\$75,000	0.30%	\$0	\$93,225	25	\$93,225.00	\$0.00	\$0.00	\$0.00	\$0.00	\$93,225.00
22	Plumbing	\$430,000	1.74%	\$0	\$534,490	40	\$534,490.00	\$0.00	\$0.00	\$400,867.50	(\$400,867.50)	\$133,622.50
23	HVAC	\$835,000	3.37%	\$20,000	\$1,037,905	25	\$1,037,905.00	\$0.00	\$0.00	\$0.00	\$0.00	\$1,037,905.00
26	Electrical	\$2,200,000	8.88%	\$30,000	\$2,734,600	25	\$2,734,600.00	\$0.00	\$0.00	\$0.00	\$0.00	\$2,734,600.00
31	Earthwork	\$354,500	1.43%	\$0	\$440,644	50	\$0.00	\$0.00	\$0.00	\$0.00	\$0.00	\$0.00
32	Exterior Improvements	\$390,500	1.58%	\$0	\$485,392	40	\$485,391.50	\$0.00	\$0.00	\$364,043.63	(\$364,043.63)	\$121,347.88
33	Utilities	\$3,804,750	15.36%	\$0	\$4,729,304	50	\$0.00	\$0.00	\$0.00	\$0.00	\$0.00	\$0.00
40	Process Piping	\$2,950,000	11.91%	\$10,000	\$3,666,850	25	\$3,666,850.00	\$0.00	\$0.00	\$0.00	\$0.00	\$3,666,850.00
43	Process Pumps/Meters	\$110,000	0.44%	\$5,000	\$136,730	30	\$136,730.00	\$0.00	\$0.00	\$45,576.67	(\$45,576.67)	\$91,153.33
44	Process Equipment	\$4,406,000	17.79%	\$75,000	\$5,476,658	25	\$5,476,658.00	\$0.00	\$0.00	\$0.00	\$0.00	\$5,476,658.00
TOTALS		\$24,766,000	100.00%	\$165,000	\$30,780,000							\$13,985,687

50 Year Life Cycle (Present Worth)		20 year Annual Costs		Inflation = 2.75%
Capital Project Costs	\$30,780,000	Loan Payment	\$1,882,404	Interest = 2.00%
Equipment Replacement	\$13,985,687	Annual Equipment Replacement	\$445,069	Financing Years= 20
Labor	\$6,488,398	Labor	\$110,000	
Gas	\$1,179,709	Gas	\$20,000	
Chemicals	\$6,488,398	Chemicals	\$110,000	3 mgd, 2 mg/L Cl @ \$1/lb, 1 mg/L NaMnO4 @ \$10/gal, 2 mg/L phosphate @ \$5/gal
Insurance	\$589,854	Insurance	\$10,000	
Electricity	\$6,193,471	Electricity	\$105,000	Assumes 120kW 24/7 at \$0.10 per kWh
Equip. Repair	\$9,732,597	Equip. Repair	\$165,000	
TOTAL PW	\$75,440,000	TOTAL ANNUAL COST:	\$2,847,000	



Building a Better World for All of Us[®]

Sustainable buildings, sound infrastructure, safe transportation systems, clean water, renewable energy and a balanced environment. Building a Better World for All of Us communicates a company-wide commitment to act in the best interests of our clients and the world around us.

We're confident in our ability to balance these requirements.

[Join Our Social Communities](#)

