



## **NOTICE OF REGULAR COUNCIL MEETING**

In accordance with Section 38-431.01 of the Arizona Revised Statutes of the State of Arizona, notice is hereby given to the Members of City Council and to the general public that the Mayor and Council of the City of San Luis, Arizona will hold a Regular City Council meeting at 7:00 p.m. Wednesday, June 8, 2016. The meeting will take place at the City Council Chambers, located at 1090 E. Union Street, San Luis, Arizona, 85349. Everyone from the public is invited to attend the open meeting.

In accordance with the Americans with Disabilities Act (ADA) and Section 504 of the Rehabilitation Act of 1973, the City of San Luis does not discriminate on the basis of disability in the admission of or access to, or treatment of employment in its programs, activities, or services. For information regarding rights and provisions of the ADA or Section 504, or to request reasonable accommodations for participation in City programs, activities or services contact: ADA/Section 504 Coordinator, City of San Luis Human Resources Department, 1090 E. Union Street, San Luis, Arizona, 85349, (928) 341-8520.

Notice is hereby given that pursuant to A.R.S. §1-602.A.9, subject to certain specified statutory exceptions, parents have a right to consent before the State or any of its political subdivisions make a video or audio recording of a minor child. Meetings of the City Council are audio and/or video recorded, and, as a result, proceedings in which children are present may be subject to such recordings. Parents in order to exercise their rights may either file written consent with the City Clerk to such recordings, or take personal action to ensure that their child or children are not present when a recording may be made. If a child is present at the time a recording is made, the City will assume that the rights afforded parents pursuant to A.R.S. §1-602.A.9 have been waived.

THIS NOTICE IS APPROVED BY:

/s/ Sonia Cornelio, City Clerk

## **AVISO DE JUNTA REGULAR**

De acuerdo a la Sección 38-431.01 de los Estatutos Revisados del Estado de Arizona, se le informa a los Miembros del Cabildo y al público en general que el Alcalde y el Cabildo de San Luis, Arizona, tendrán una Junta Regular a las 7:00 p.m. el día Miércoles, 8 de Junio del 2016. La junta se llevará a cabo en la Sala del Cabildo, ubicada en el 1090 E. Union Street, San Luis, Arizona, 85349, el público está cordialmente invitado.

De acuerdo con el Acta de Americanos con Discapacidades y la Sección 504 del Acta de Rehabilitación del 1973, la Ciudad de San Luis no discrimina por causa de discapacidad la admisión y acceso a sus programas, actividades, servicios o en el trato en cuanto a empleo. Para más información referente a derechos y provisiones del Acta de Americanos con Discapacidades o Sección 504, o para solicitar adaptaciones que sean razonables para la participación en programas, actividades o servicios de la Ciudad, contactar al: Coordinador del Acta de Americanos con Discapacidades/Sección 504, Departamento de Recursos Humanos de la Ciudad de San Luis, 1090 E. Union Street, San Luis, Arizona, 85349, (928) 341-8520.

Por medio de este aviso y de acuerdo con los Estatutos Revisados del Estado de Arizona, sujeto a ciertas excepciones reglamentarias, los padres de familia tienen el derecho de dar o no dar el consentimiento antes que el Estado o alguna subdivisión política grabe a un menor de edad, ya sea en audio o video. Las juntas del Cabildo se graban en audio y/o video y como resultado, el hecho de que haya menores presentes puede ser sujeto a que sean grabados. Para que los padres de familia puedan ejercer sus derechos, favor de autorizar por escrito con la Secretaria de la Ciudad a tal grabación, o tomar acción personal para asegurarse que su hijo/hija menor no esté presente cuando la grabación se lleve a cabo. Si un menor de edad está presente en el momento de la grabación, la Ciudad asumirá que los padres de familia están cediendo los derechos sobre una posible grabación de acuerdo con el Estatuto Revisado del Estado de Arizona §1-602.A.9.

ESTE AVISO ES APROBADO POR:

/f/ Sonia Cornelio, Actuaría de la Ciudad



**AGENDA**  
**Regular Meeting**  
**San Luis City Council**  
**San Luis Council**  
**Chambers**  
**1090 E. Union Street**  
**San Luis, AZ 85349**  
**June 8, 2016**  
**7:00 p.m.**

**AMENDED**  
**JUNE 7, 2016**

**MEMBERS OF THE CITY COUNCIL WILL ATTEND EITHER IN PERSON, TELEPHONE, OR VIDEO CONFERENCE COMMUNICATION**

**1. CALL TO ORDER/ROLL CALL**

**2. PLEDGE OF ALLEGIANCE**

**3. INVOCATION**

**4. CONSENT AGENDA**

All matters are considered to be routine by the City Council and will be enacted by one motion. If discussion is desired, that item will be removed from the Consent Agenda and will be considered separately.

**4. A. MINUTES OF**

- Special Council meeting held March 2, 2016
- Special Council meeting held April 14, 2016
- Budget Retreat held April 15 & 16, 2016
- Work Session held April 20, 2016
- Regular Council meeting held April 27, 2016

**4. B. DISBURSEMENTS FROM MAY 16, 2016 THROUGH MAY 27, 2016**

Total Disbursements \$722,289.53

(Seven Hundred Twenty-Two Thousand, Two Hundred Eighty-Nine Dollars and Fifty-Three Cents)

**4. C.**

Discussion and possible action on any and all matters regarding the adoption of Resolution No. 1148. A resolution of the Mayor and Council of the City of San Luis, Arizona, authorizing the City Manager to amend the Classification and 2006 Salary Plan of the City of San Luis; create certain positions; and make other personnel and departmental changes to include transfers within the organization, in preparation for fiscal year 2016-2017. **(Tadeo A. De La Hoya, Interim City Manager)**

4. D. Discussion and possible action on any and all matters regarding the matter of the appeal of APS vs. City of San Luis in the Arizona Tax Court Case Number TX 2014-000404. **(Kay Marion Macuil, City Attorney)**
5. **DISCUSSION AND POSSIBLE ACTION ITEMS:**
5. A. Discussion and possible action on any and all matters regarding ratifying a contract for a Judge Pro Tempore / Administrative Manager for the San Luis Municipal Court. **(Kay Marion Macuil, City Attorney and Tadeo A. De La Hoya, Interim Manager)**
5. B. Discussion and possible action on any and all matters pertaining to the approval to award the 300 thousand gallons, tank (Well Site #3) & 500 thousand gallons, tank (Well Site #4) Maintenance/Rehabilitation Project contract to Revolution Industrial. **(Manuel Rojas, Assistant Public Works Director)**
5. C. Public hearing followed by discussion and possible action on any and all matters regarding recommendation of a Special Event Liquor License application to the Arizona Department of Liquor Licenses and Control to authorize San Luis FRONTERA Rotary Club to sell alcohol on July 04, 2016. **(Marcos Ramirez, President of the San Luis FRONTERA Rotary Club & Jennifer Cisneros, Acting Parks & Recreation Director)**
- A. Open public hearing
1. Staff Presentation
2. Call to the Public on this item
- B. Close public hearing
- C. Action on Special Event Liquor License Application to the Arizona Department of Liquor Licenses & Control
5. D. Discussion and possible action on any and all matters regarding reconsideration of Ordinance No. 354. An ordinance related to the Tax Code of the City of San Luis relating to the use Tax Rate for Purchases of Tangible Personal Property. **(Kay Marion Macuil, City Attorney)**
5. E. Discussion and possible action on any and all matters regarding a motion to deny adoption of Ordinance No. 354. An ordinance related to the Tax Code of the City of San Luis relating to the use Tax Rate for Purchases of Tangible Personal Property. **(Kay M. Macuil, City Attorney)**
5. F. Discussion and possible action on any and all matters regarding the acceptance of bid for the extension of two 12" ductile iron discharge pipes at the east wastewater treatment plant. **(Eulogio Vera, Director of Public Works).**
5. G. Discussion and possible action on any and all matters regarding Text Amendment Case No. 2016-0204 and Second Reading of Ordinance No. 350. An ordinance of the Mayor and Council of the City of San Luis, Arizona, amending the San Luis City Code, Chapter 152 Zoning Regulations, Section 152.259(B) and 152.260 relating to temporary signs and political signs; repealing any conflicting provisions; and providing for severability. **(John Starkey, Zoning Administrator)**
- A. Approval of Second Reading of Ordinance No. 350 by title only
- B. Approval and adoption of Ordinance No. 350

**6. SUMMARY OF CURRENT EVENTS**

Events by Mayor, Council Members, City Manager, and/or City Staff pursuant to A.R.S. §38-431.02 (K).

**7. CALL TO THE PUBLIC**

This is the time for the public to comment. Members of the City Council may not discuss items that are not specifically identified on the agenda. Therefore, pursuant to A.R.S. §38-431.01 (H), action taken as a result of public comment will be limited to directing staff to study the matter, responding to any criticism or scheduling the matter for further consideration and decision at a later date.

**8. EXECUTIVE SESSIONS**

Vote to hold Executive Sessions pursuant to A.R.S. §38-431.03.(A), (1), (3), (4), (5) and (7)

- 8. A.** Discussion and possible action to hold an executive session pursuant to A.R.S. §38-431.03(A)(3), A.R.S. §38-431.03(A)(4) and A.R.S. §38-431.03(A)(5) on any and all matters regarding discussion or consultation for legal advice with the City Attorney or City's attorneys to consider the City Council's position and instruct its Attorney or attorneys regarding staffing and or compensation contracts of public safety personnel of the San Luis Fire Department. **(Kay Marion Macuil, City Attorney)**
- 8. B.** Discussion and possible action to hold an executive session pursuant to A.R.S. §38-431.03(A) subsection (3) and (4) on any and all matters relating to San Luis Facility Development Corporation versus CEC Federal Case No. CV 14-02633 PHX MEA and related contracts for discussion or consultation for legal advice with the City Attorney or City's attorneys and in order to consider the City's position and instruct its attorneys. **(Kay Marion Macuil, City Attorney)**
- 8. C.** Discussion and possible action to hold an Executive Session pursuant to A.R.S. §§38-431.03(A) subsections (3), (4), and (7) for legal advice and consider the City's position and instruct its Attorney with respect to two (2) potential projects the potential purchase of land, financing, and potential lease for a possible commercial development and possible commercial lease contracts that are the subject of negotiations for the Price Center Building. **(Kay Marion Macuil, City Attorney)**
- 8. D.** Discussion and possible action to hold an executive session pursuant to A.R.S. §38-431.03(A) subsections (1),(3) and (4) on any and all matters relating to the position of Magistrate to discuss or consider employment, assignment, appointment, including possible discussion of confirmation of appointment and/or discussion of approval of terms and/or conditions pursuant to San Luis City Code §34.20, and consultation with the City Attorney or City's attorneys regarding the same. **(Kay Marion Macuil, City Attorney)**
- 8. E.** Discussion and possible action to hold an executive session pursuant to A.R.S. §§38-431.03(A) subsections (3), and (4) for discussion or consideration of any and all matters relating to the independent contract of the Consultant to the Interim City Manager and City Council to discuss or consider approval of amending terms and/or conditions and consultation with the City Attorney or City's attorneys regarding the same. **(Kay Marion Macuil, City Attorney)**
- 9. MOTION TO GO BACK TO REGULAR SESSION**

**10. DISCUSSION AND POSSIBLE ACTION ITEMS:**

**10. A.** Discussion and possible action regarding any and all matters related to appointment of a Magistrate. **(Kay Marion Macuil, City Attorney)**

**10. B.** Discussion and possible action regarding any and all matters related to amendments to the independent contract of Consultant to the Interim City Manager and to City Council. **(Kay Marion Macuil, City Attorney)**

**11. ADJOURNMENT**



## AGENDA ITEM REVIEW FORM

### Regular City Council Meeting

4. A.

Meeting Date: 06/08/2016

---

#### Summary

#### **MINUTES OF**

- Special Council meeting held March 2, 2016
  - Special Council meeting held April 14, 2016
  - Budget Retreat held April 15 & 16, 2016
  - Work Session held April 20, 2016
  - Regular Council meeting held April 27, 2016
- 

#### Attachments

- March 2, 2016 SCM
  - April 14, 2016 SCM
  - April 15 & 16, 2016 Budget Retreat
  - April 20, 2016 WS
  - April 27, 2016 RCM
-

**MINUTES**  
**Special Meeting**  
**San Luis City Council**  
**San Luis Council Chambers**  
**1090 E. Union Street**  
**San Luis, AZ 85349**  
**March 2, 2016**  
**6:30 P.M.**

1. **CALL TO ORDER:** Mayor Gerardo Sanchez called the Regular City Council meeting to order at approximately 6:38 p.m.

**ROLL CALL:**

**PRESENT:** Mayor Gerardo Sanchez  
Vice-Mayor Matias Rosales  
Council Member Mario Buchanan Jr.  
Council Member Maria Cecilia Ramos (arrived at 6:44 p.m.)  
Council Member Ruben Walshe

**ABSENT:** Council Member Africa Luna-Carrasco  
Council Member Gloria Torres

**OTHERS PRESENT:** Tadeo De La Hoya, Interim City Manager  
Ralph Velez, City Consultant  
Sonia Cornelio, City Clerk  
Christine Hagen, Management Analyst  
Craig Higgins, Chief of Police  
Derek Dueñas, Acting I.T. Manager  
Hank Green, Fire Chief  
Jenny Torres, Community Development Director  
John Starkey, Zoning Administrator  
Johnathan Dumadag, I.T. Technician  
Joselyn Medina, PIO/ Assistant to Council  
Kay Macuil, City Attorney  
Katie St. Louis, Finance Director  
Yolanda Dueñas, Fleet/Facilities Manager

2. **PLEDGE OF ALLEGIANCE:**

The Pledge of Allegiance was led by Council Member Ruben Walshe.

### **3. DISCUSSION AND POSSIBLE ACTION ITEM(S):**

**3. A. Discussion and possible action on any and all matters regarding Resolution No. 1134. A resolution of the City Council of the City of San Luis, Arizona, authorizing the Mayor to execute an Intergovernmental Cooperative Agreement between the City of San Luis, City of Somerton, City of Yuma, County of Yuma, and Town of Wellton for the Consortium of the Federal HOME Program. (Jenny Torres, Community Development Director)**

Ms. Jenny Torres, Community Development Director, provided a PowerPoint presentation pertaining to the HOME Investment Partnership Program. Ms. Torres recommended approval of Resolution No. 1134, as it would approve the Intergovernmental Agreement.

Mayor Gerardo Sanchez asked if it had been done before.

Ms. Torres replied that it had not been done in the City of San Luis and added that it has been done in Maricopa and Pima.

Vice Mayor Matias Rosales asked how the selection process would go if it passes.

**MOTION:** Vice-Mayor Matias Rosales/ Council Member Maria Cecilia Ramos to approve and adopt Resolution No. 1134. Motion passed unanimously.

**3. B. Discussion and possible action on any and all matters regarding a contract to temporarily cover the Municipal Court after the retirement of Magistrate Rosendo Morales, Jr. (Tadeo A. De La Hoya, Interim Manager)**

Mr. Tadeo De La Hoya, Interim City Manager, stated that Judge Nelson issued an Administrative Order No. 2016-03 designating Justice of the Peace Juan Manuel Guerrero as the City of San Luis temporary Magistrate and was sworn in early that day.

Mayor Gerardo Sanchez asked how much money was allocated for the remaining of the year.

Mr. De La Hoya replied that there was approximately \$25,000.00 in the salary budget and added that Magistrate Guerrero would be employed under a contractual basis and not as an employee of the City.

Mayor Gerardo Sanchez asked what the biweekly salary will be.

Mr. De La Hoya replied that it would be \$1,336.40 biweekly until the position is filled by the appointment of a Magistrate by City Council.

Ms. Macuil added that the compensation will be up to the City of San Luis.

**MOTION:** Council Member Mario Buchanan Jr./Council Member Ruben Walshe to approve, adopt, and ratify the contract for Magistrate pending permanent appointment. Motion passed unanimously.

Ms. Kay Macuil, City Attorney, introduced the Chairman of the Board of Emerald to the City Council as well as the Warden of the Detention Center. Ms. Macuil also introduced Mr. Steve Afeman, Chief Executive Officer of Emerald and Mr. Sam Youngblood, owner of Emerald.

Mayor Gerardo Sanchez stated that the City of San Luis is committed to working together and thanked Mr. Youngblood for working with the City of San Luis.

Mayor Gerardo Sanchez opened Call to the Public; there was no opposition from the City Council.

Mr. Matias Rosales, 1509 N. 7th Avenue, stated that several parents including himself have been concerned that the snack shop at Joe Orduño Park had been closed down. Mr. Rosales added that it has resulted with the children having no access to water or snacks at the park and the children crossing Juan Sanchez Boulevard in the dark to get access to snacks and water.

Mayor Gerardo Sanchez clarified that no action or motion can be taken as the item was not on the Agenda.

#### **4. EXECUTIVE SESSION:**

**MOTION:** Council Member Mario Buchanan Jr./ Council Member Ruben Walshe to go to Executive Session at approximately 7:00 p.m. Motion passed unanimously.

**4. A. Discussion and possible action to hold an executive session pursuant to A.R.S. §§38-431.03(A) (3) and 38-431.03(A) (4) for consultation for legal advice with the City Attorney and/or attorneys for the City and to consider instructing the City Attorney regarding any all matters regarding the San Luis Regional Detention Center and related contracts that are subject of negotiations, in pending or contemplated litigation or in settlement discussions conducted in order to avoid or resolve litigation. (Kay Marion Macuil, City Attorney)**

#### **5. MOTION TO GO BACK INTO REGULAR SESSION:**

**MOTION:** Vice-Mayor Matias Rosales/ Council Member Mario Buchanan Jr. to go back to Regular Session at approximately 8:18 p.m. Motion passed unanimously.

**6. ADJOURNMENT:**

**MOTION:** Vice-Mayor Matias Rosales/ Council Member Mario Buchanan Jr. to adjourn the Special Council Meeting at approximately 8:18 p.m. Motion passed unanimously.

**MINUTES**  
**Special Meeting**  
**San Luis City Council**  
**San Luis Council Chambers**  
**1090 E. Union Street**  
**San Luis, AZ 85349**  
**April 14, 2016**  
**6:30 P.M.**

1. **CALL TO ORDER** Mayor Gerardo Sanchez called the Regular City Council meeting to order at approximately 6:38 p.m.

**ROLL CALL**

**PRESENT:** Mayor Gerardo Sanchez  
Vice-Mayor Matias Rosales  
Council Member Africa Luna-Carrasco  
Council Member Maria Cecilia Ramos  
Council Member Gloria Torres arrived at approx. 7:00 p.m.  
Council Member Ruben Walshe

**ABSENT:** Council Member Mario Buchanan Jr.

**OTHERS PRESENT:** Tadeo De La Hoya, Interim City Manager  
Ralph Velez, City Consultant  
Sonia Cornelio, City Clerk  
Aracely De La Hoya, Senior Services Director  
Christine Hagen, Management Analyst  
Chris Kasid, Parks and Recreation Manager  
Craig Higgins, Chief of Police  
Derek Dueñas, I.T. Manager  
Eulogio Vera, Public Works Director  
Hank Green, Fire Chief  
Jennifer Cisneros, Asst. Parks and Recreation Director  
Jenny Torres, Community Development Director  
John Starkey, Building Safety Director  
Jonathan Dumadag, I.T. Specialist  
Joselyn Medina, PIO/Assistant to Council  
Kay Macuil, City Attorney  
Marc Holyfield, Fire Department  
Olivia Jenkins, Utilities Director  
Omar Velazquez, Parks Supervisor  
Victor Figueroa, Police Department  
Yolanda Dueñas, Fleet/ Facilities Manager  
Caty Navarro, Regional Center for Border Health  
Charles Gutierrez, Yuma Metropolitan Planning Organization

Diane Umphress, Amberly's Place Executive Director  
Eduardo Garcia, Factor Sales  
Javier Morales, Regional Center for Border Health

## **2. PLEDGE OF ALLEGIANCE**

The pledge of allegiance was led by Council Member Maria Cecilia Ramos.

## **3. INVOCATION**

The invocation was led by Mr. Hank Green, Fire Chief.

## **4. PRESENTATIONS**

### **4. A. Presentation on the San Luis Transit Route Circulation Study by Yuma Metropolitan Planning Organization (YMPO). (Charlene Fitzgerald, YMPO Executive Director)**

Mr. Charles Gutierrez, YMPO, stated that Alex Lane from Kimmely Horn and Charlie Krueger from YCIPTA would be discussing the San Luis Circulation that will be implemented within six (6) months and one (1) year. Mr. Lane explained that there are four (4) potential routes that would be beneficial to the City of San Luis that would be running from 5:00 a.m. to 10:00 p.m. Monday through Friday and from 5:00 a.m. to 6:00 p.m. on Saturday with sixty (60) minutes in between buses on a fixed route.

Ms. Shelly Kreger presented Mayor and Council with a pamphlet that includes general information of YCIPTA and YCAT. Ms. Kreger also provided more information about the circulator funding. (First name corrected from original May 25, 2016 Agenda.)

Mayor Gerardo Sanchez stated that he would personally like to see the correct numbers and asked for access to the survey conducted.

### **4. B. Presentation including video on Amberly's Place and Child Abuse Awareness month as well as the upcoming events in the community. (Diane Umphress, Executive Director of Amberly's Place)**

Ms. Diane Umphress, Executive Director of Amberly's Place, stated that April is child abuse awareness month and encourages others to report any child abuse incident. Ms. Umphress presented a video about child abuse awareness month and thanked Mayor and Council for their ongoing support.

## **5. PROCLAMATIONS**

### **5. A. Healthy Sister Cities Border Initiative**

Ms. Sonia Cornelio, City Clerk, read the proclamation in its entirety.

Mayor Gerardo Sanchez thanked the Regional Center for Border Health for thinking of the City of San Luis.

### **5. B. National Public Safety Telecommunications Week- April 10 through April 16, 2016**

Ms. Sonia Cornelio, City Clerk, read the proclamation in its entirety.

Mayor Gerardo Sanchez stated that the Public Safety Telecommunications are a critical part of the City of San Luis and thanked them for everything they do.

## **6. CONSENT AGENDA**

### **6. A. Minutes of**

-Regular Council Meeting held February 24, 2016

### **6. B. Disbursements from March 14, 2016 through April 1, 2016**

Total Disbursements \$765,272.72

(Seven Hundred Sixty-Five Thousand, Two Hundred Seventy-Two Dollars and Seventy-Two Cents)

**6. C. Discussion and possible action on any and all matters regarding the authorization to purchase ten (10) portable radios from Motorola through the Arizona Department of Homeland Security Grant. (Craig Higgins, Chief of Police)**

**6. D. Discussion and possible action on any and all matters regarding the transferring of funds from Council's Contingency account to the Capital Outlay General Fund account to purchase two (2) servers as well as software and software licensing. (Derek Dueñas, Acting I.T. Manager)**

**6. E. Discussion and possible action on any and all matters regarding the City of San Luis entering into contract with American Pavement Preservation for application of type 2 and type 3 slurry seal as part of the 2016 Pavement Preservation Project. (Eulogio Vera, Director of Public Works)**

**6. F. Discussion and possible action on any and all matters regarding the approval of Pace Advance Water Engineering contract for engineering design and construction services for the East Wastewater Treatment Plant Basin Repair Project. (Eulogio Vera, Director of Public Works)**

**6. G. Discussion and possible action on any and all matters regarding Resolution No. 1141. A resolution of the Mayor and City Council of the City of San Luis, Arizona, declaring as a public record that certain document filed with the City Clerk and entitled "2015 S-2 Supplement to the Code of Ordinance of the City of San Luis, Arizona." (Kay Macuil, City Attorney)**

**MOTION:** Council Member Gloria Torres/Council Member Africa Luna-Carrasco to approve the Consent Agenda as presented. Motion passed unanimously.

**7. DISCUSSION AND POSSIBLE ACTION ITEMS:**

**7. A. Discussion and possible action on any and all matters regarding the purchase of artificial turf for the conversion of the old tennis court or basketball court at Joe Orduño Park to the futsal soccer field. (Chis Kasid, Parks and Recreation Director)**

Mr. Chis Kasid, Parks and Recreation Director, stated that new quote was received for a total of \$135,000.00 for turf to be installed on the basketball court. If the purchase is approved construction will be ready to go on the second or third week of May and will be finished in approximately one (1) week to ten (10) days.

Vice-Mayor Matias Rosales asked if the old tennis court is still planned to be converted into batting cages.

Mr. Kasid replied that it would be added to the budget and discussed during the Budget Retreat. He added that it would be a great idea and that the basketball court in the front is also in need of an update.

**MOTION:** Vice- Mayor Matias Rosales/Council Member Maria Cecilia Ramos approved the purchase of the artificial turf and installation in the amount of \$135,000.00 to be installed on a concrete basketball court slab on the east side as presented. Motion passed with five (5) aye votes and one (1) nay vote from Council Member Africa Luna-Carrasco.

**7. B. Discussion and possible action on any and all matters regarding First Reading of Ordinance No. 349 by title only. An ordinance of the Mayor and City Council of the City of San Luis, Arizona, enacting and adopting a supplement to the Code of Ordinance for the City of San Luis, Arizona; repealing any conflicting provisions; and providing for severability. (Kay Macuil, City Attorney)**

Ms. Kay Macuil, City Attorney, stated that this Ordinance will be to add the remaining ordinances that have been adopted to the City Code book.

**A. Approval of First Reading of Ordinance No. 349 by title only.**

**MOTION:** Vice-Mayor Matias Rosales/Council Member Gloria Torres to approve the First Reading of Ordinance No. 349 by title only. Motion passed unanimously.

Ms. Sonia Cornelio, City Clerk, read Ordinance No. 349 by title only.

Mayor Gerardo Sanchez addressed the public that the next three items would be discussed at the same time as they are all related. Therefor the Public Hearing will be opened and closed just once.

**7. C. Public Hearing followed by discussion and possible action on any and all matters regarding Resolution No. 1138. A resolution of the Mayor and Council of the City of San Luis, Arizona, approving and adopting the City of San Luis Title VI Implementation Plan Relating to Transportation Services. (Christine Hagen, Management Analyst)**

**A. Open Public Hearing**

**MOTION:** Council Member Gloria Torres/Council Member Africa Luna-Carrasco to open Public Hearing. Motion passed unanimously.

Ms. Christine Hagen, Management Analyst, stated that the City of San Luis, Arizona will be applying for Section 5310 Grant adding that part of the grant is to have a Title IV no discrimination policy.

Mayor Gerardo Sanchez, asked if a similar policy was already enforced at the City of San Luis.

Ms. Kay Macuil, City Attorney, replied that the City of San Luis complies with the law but there is nothing in writing.

Ms. Hagen added there is a strong need for this grant, as some of the City vehicles are more than sixteen (16) year old. She also stated that the wheelchair lift on the Senior Center buses do not work on a regular bases.

#### **B. Close Public Hearing**

**MOTION:** Council Member Gloria Torres/Council Member Ruben Walshe to close Public Hearing. Motion passed unanimously.

#### **C. Action on Resolution No. 1138**

**MOTION:** Council Member Ruben Walshe/Council Member Africa Luna-Carrasco to approve and adopt Resolution No. 1128. Motion passed unanimously.

**7. D. Public Hearing followed by discussion and possible action on any and all matters regarding Resolution No. 1139. A resolution of the Mayor and Council of the City of San Luis, Arizona, approving and adopting the City of San Luis Limited English Proficiency Plan. (Christine Hagen, Management Analyst)**

#### **A. Open Public Hearing**

This public hearing was opened and closed with the previous item.

#### **B. Close Public Hearing**

#### **C. Action on Resolution No. 1139**

**MOTION:** Council Member Africa Luna-Carrasco/Council Member Maria Cecilia Ramos to approve and adopt Resolution No. 1139. Motion passed unanimously.

**7. E. Public Hearing followed by discussion and possible action on any and all matters regarding Resolution No. 1140. A resolution of the Mayor and Council of the City of San Luis, Arizona, approving a grant application to obtain vehicles to enhance mobility of seniors and individuals with disabilities through the Arizona Department of Transportation for funds from the Federal Transit Administration Section 5310. (Christine Hagen, Management Analyst)**

#### **A. Open Public Hearing**

This Public Hearing was opened and closed with the previous item.

#### **B. Close Public Hearing**

### **C. Action on Resolution No. 1140**

**MOTION:** Council Member Ruben Walshe/Council Member Maria Cecilia Ramos to approve and adopt Resolution No. 1140. Motion passed unanimously.

### **8. SUMMARY OF CURRENT EVENTS**

Council Member Maria Cecilia Ramos stated that she attended the Girls All-Star Softball League on April 13, 2016 and thanked Parks and Recreation for their hard work and efforts.

Mayor Gerardo Sanchez stated that he and Vice Mayor Matias Rosales were part of a welcoming committee to welcome a group called ACE that represents different parts of the world. Mayor Gerardo Sanchez added that the Budget Retreat will be from April 15, 2016 to April 17, 2016.

Mr. Tadeo De La Hoya, Interim City Manager, added that the Budget Retreat will be streaming live from the City of San Luis Council Chambers.

### **9. CALL TO THE PUBLIC**

Mr. Javier Morales, Regional Center for Border Health, thanked the City of San Luis for having a proclamation designating the City of San Luis and San Luis Rio Colorado as Healthy Sisters Cities.

Mayor Gerardo Sanchez, on behalf of council and himself, thanked Mr. Chris Kasid for everything he has done for the City of San Luis and his hard work.

### **10. ADJORNMENT**

**MOTION:** Council Member Gloria Torres/Council Member Ruben Walshe move to adjourn the Special Council Meeting at approximately 7:38 p.m.

**MINUTES**  
**Budget Retreat**  
**City of San Luis**  
**Talking Stick Resort**  
**9800 E. Indian Bend Rd.**  
**Scottsdale, AZ 85256**

**April 15, 2016 starting at 5:00 p.m.**

**April 16, 2016 starting at 8:00 a.m.**

**THE PUBLIC MAY ATTEND AND LISTEN TO THE PROCEEDINGS EITHER AT TALKING STICK RESORT LOCATED AT 9800 E. INDIAN BEND RD., SCOTTSDALE, AZ 85256**

**1. CALL TO ORDER:** Mayor Gerardo Sanchez called the Budget Retreat to order on April 15, 2016 at approximately 5:48 p.m.

**PRESENT:** Mayor Gerardo Sanchez  
Vice Mayor Matias Rosales  
Council Member Gloria Torres  
Council Member Mario Buchanan Jr.  
Council Member Africa Luna-Carrasco  
Council Member Maria Cecilia Ramos  
Council Member Ruben Walshe (arrived at approximately 7:37 p.m.)

**OTHERS PRESENT:** Tadeo De La Hoya, Interim City Manager  
Ralph Velez, City Consultant  
Sonia Cornelio, City Clerk  
Aracely De La Hoya, Senior Services Director  
Carlos Cortes, Assistant Finance Director  
Craig Higgins, Chief of Police  
Derek Dueñas, Acting I.T. Manager  
Eulogio Vera, Public Works Director  
Hank Green, Fire Chief  
Jenny Torres, Community Development Director  
Joselyn Medina, PIO/ Assistant to Council  
John Starkey, Zoning Administrator/ Building and Safety Director  
Kay Macuil, City Attorney  
Ketie St. Louis, Finance Director  
Manuel Rojas, Assistant Public Works Director  
Marc Holyfield, Assistant Fire Chief  
Maria Sabori, Human Resources Senior Analyst  
Olivia Jenkins, Utilities Director  
Roula Encinas, Accountant  
Victor Figueroa, Lieutenant  
Yolanda Dueñas, Fleet/Facilities Director

Mayor G. Sanchez thanked everyone for attending.

## **2. DISCUSSION ITEMS, NO ACTION WILL BE TAKEN**

**2. A. Discussion and review on any and all matters regarding the proposed City of San Luis Fiscal Year 2016-2017 Budget. (April 15, 2016 from 5:00 p.m. to 7:00 p.m.)**

### **POLICE DEPARTMENT**

Mr. Craig Higgins, Chief of Police, explained the services provided, department's organization, accomplishments, goals and objectives of the Police Department.

Mr. Victor Figueroa, Lieutenant, explained the department's 2016-2017 budget requests through a Power Point presentation. Comments, questions, and answers occurred amongst Elected Officials and Staff. **(COPY OF THE POWERPOINT PRESENTATION WAS NOT PROVIDED TO THE CITY CLERK'S OFFICE)**

### **FIRE DEPARTMENT**

Mr. Hank Green, Fire Chief, presented a Power Point presentation to explain the Department's General Fund and Ambulance Services Enterprise Funds for Fiscal Year 2016-2017. **(COPY OF THE POWERPOINT PRESENTATION WAS NOT PROVIDED TO THE CITY CLERK'S OFFICE)**

Discussion between Mayor, Council, Interim City Manager, and Mr. Green occurred.

Mayor Gerardo Sanchez commented that he understands the importance of Public Safety, adding that it is getting expensive to provide the services presented.

**MOTION:** Vice-Mayor Matias Rosales/ Council Member Mario Buchanan Jr. to recess the Budget Retreat at approximately 7:44 p.m. Motion passed unanimously.

### **BUDGET RETREAT APRIL 16, 2016**

**ROLL CALL:** Mayor Gerardo Sanchez called the Budget Retreat to order and reconvened on April 16, 2016 at 8:20 a.m.

**PRESENT:**

- Mayor Gerardo Sanchez
- Vice Mayor Matias Rosales
- Council Member Gloria Torres
- Council Member Mario Buchanan Jr.
- Council Member Africa Luna-Carrasco
- Council Member Maria Cecilia Ramos
- Council Member Ruben Walshe

**OTHERS PRESENT:** Tadeo De La Hoya, Interim City Manager

Ralph Velez, City Consultant  
Sonia Cornelio, City Clerk  
Andrea Ruiz, Court Administrator (arrived at approximately 12:20 p.m.)  
Aracely De La Hoya, Senior Services Director  
Carlos Cortes, Assistant Finance Director  
Craig Higgins, Chief of Police  
Derek Dueñas, Acting I.T. Manager  
Eulogio Vera, Public Works Director  
Hank Green, Fire Chief  
Jennifer Cisneros, Acting Parks and Recreation Director  
Jenny Torres, Community Development Director  
Jose de la Vara, City Prosecutor  
Joselyn Medina, PIO/ Assistant to Council  
John Starkey, Zoning Administrator/ Building and Safety Director  
Kay Macuil, City Attorney  
Katie St. Louis, Finance Director  
Manuel Rojas, Assistant Public Works Director  
Marc Holyfield, Assistant Fire Chief  
Maria Elena Cruz, Presiding Judge (arrived at approximately 12:20 p.m.)  
Maria Sabori, Human Resources Senior Analyst  
Olivia Jenkins, Utilities Director  
Roula Encinas, Accountant  
Victor Figueroa, Lieutenant  
Yolanda Dueñas, Fleet/Facilities Director

**2. B. Discussion on any and all matters regarding the proposed changes to the City of San Luis benefits plan for Fiscal Year 2016-2017 presented by Ms. Susan Posada, City of San Luis Benefits Consultant. (April 16, 2016 from 8:00 a.m. to 8:30 a.m.)**

Ms. Susan Posada, City of San Luis Benefits Consultant, provided a Power Point presentation to Mayor, Council, and City Staff and explained the proposed changes to the plan costs, including Mayo Fees, SSA Mexico Network, Siarmed, Broker fees, BCBS network fees, and ACA fees. A copy of the Power Point presentation can be found in the City of San Luis Clerk's Office.

Mayor Gerardo Sanchez commented that the proposed changes will not have a big impact

**2. C. Discussion and review on any and all matters regarding the proposed City of San Luis Fiscal Year 2016-2017 Budget. (April 16, 2016 from 8:30 a.m. to 5:00 p.m.)**

## **FINANCE DEPARTMENT**

Ms. Ketic St. Louis, Finance Director, presented a Power Point presentation that explained the Budget Process, Recommended Annual Budget for Fiscal Year 2017, Doing More With Less, Current Conditions and Recommended Strategies, Current Conditions, Recommended Strategies, City Wide Revenue Fiscal Year 2017 Revenues by Fund Type, Economic Recovery, Revenues Comparison, Summary of Expenses by Category, General Fund Revenues, City Sales Tax Revenue History, Major Categories of Comparison, General Fund Revenues Fiscal Year 2017, Personnel Vacancies, Temporary Personnel, City Operations Key Expense Variables, Needs for New Revenues Sources, and Next Steps. A copy of the Power Point presentation is filed with the complete Agenda Packet at the Office of the City Clerk.

Discussion between Mayor, Council, and San Luis Finance Department occurred.

Mayor Gerardo Sanchez stated that the City has been very conservative and the City is back to where it was. Mayor Gerardo Sanchez added that there are twenty (20) more employees and the City needs to continue the trend.

Department Heads, Supervisors and/or staff gave a summary of accomplishments that happened in the past year within their department. Mayor and Council also provided comments and expectations.

A recess break was given at approximately 10:15 a.m.  
The Budget Retreat reconvened at approximately 10:25 a.m.

## **PARKS AND RECREATION DEPARTMENT**

Ms. Jennifer Cisneros, Acting Parks and Recreation Director, explained some of their accomplishments, objectives, and requests.

## **FACILITIES/FLEET DEPARTMENTS**

Ms. Yolanda Dueñas, Facilities/Fleet Manager, explained the department's requests for Fleet Services and Facilities.

## **PUBLIC WORKS DEPARTMENT**

Mr. Eulogio Vera, Public Works Director, and Mr. Manuel Rojas, Assistant Public Works Director, went over Water Division, Wastewater Division, Highway User Division, and Solid Waste Division request through a Power Point presentation. **(COPY OF THE POWERPOINT PRESENTATION WAS NOT PROVIDED TO THE CITY CLERK'S OFFICE)**

## **CITY PROSECUTOR**

Mr. Jose de la Vara, City Prosecutor, provided a Power Point presentation and went over the department's accomplishments. **(COPY OF THE POWERPOINT PRESENTATION WAS NOT PROVIDED TO THE CITY CLERK'S OFFICE)**

A lunch break was given at approximately 12:48 p.m.  
The Budget Retreat reconvened at approximately 1:50 p.m.

## **MUNICIPAL COURT**

Ms. Maria Elena Cruz, Presiding Judge, provided an overview of her relationship in the capacity of Judge with the San Luis Municipal Court.

Ms. Andrea Ruiz, Court Administrator, presented a Power Point Presentation on their accomplishments, Fiscal Year 2016-2017 objectives, and requests.

## **INFORMATION TECHNOLOGY**

Mr. Derek Dueñas, Acting I.T. Manager, explained his budget requests and capital projects.

## **DEVELOPMENT SERVICES/BUILDING SAFETY DEPARTMENT**

Mr. John Starkey, Zoning Administrator/ Building and Safety Director, explained the department's objectives and request.

## **FINANCE/ RISK MANAGEMENT DEPARTMENT**

Ms. Keti St. Louis, Finance Director, explained that there are no major changes in the budgets for Finance and Risk Management.

## **CITY CLERK**

Ms. Sonia Cornelio, City Clerk, explained her requests for Fiscal Year 2016-2017.

## **CITY ATTORNEY**

Ms. Kay Macuil, City Attorney, explained her budget requests for her department.

## **COMMUNITY DEVELOPMENT**

Ms. Jenny Torres, Community Development Director, provided a Power Point presentation and explained her projects for Fiscal Year 2016-2017. **(COPY OF THE**

**POWERPOINT PRESENTATION WAS NOT PROVIDED TO THE CITY CLERK'S OFFICE)**

**UTILITIES DEPARTMENT**

Ms. Olivia Jenkins, Utilities Director, explained her budget requests for her department.

A recess break was given at approximately 3:30 p.m.  
The Budget Retreat reconvened at approximately 3:53 p.m.

**SENIOR SERVICES DEPARTMENT**

Ms. Aracely De La Hoya, Senior Services Director, explained that she does not have any major changes to her budget requests.

**HUMAN RESOURCS DEPARTMENT**

Ms. Maria Sabori, Human Resources Senior Analyst, discussed her request for Fiscal Year 2016-2017.

Comments, questions, and answers occurred amongst Elected Officials and Staff.

Mayor Gerardo Sanchez discussed the Salary Survey and stated that one of the things that has always been an issue was the lack of salary increases for City employees. Mayor Gerardo Sanchez continued to explain that when it comes to the standardization, staff should not be the one deciding them; resulting in the City of San Luis hiring an agency to do the re-classifications. He added that there are several complaints about employees losing money because of the re-classification. Mayor Gerardo Sanchez asked Ms. Maria Sabori if any employees lost money with the re-classifications.

Ms. Maria Sabori, Human Resources Senior Analyst, replied that that employees would not be losing or lost any money due to re-classifications. In addition, employees who were over the scale or years of service would keep their salary at the same amount. Ms. Sabori added that no salaries have been reduced.

Mayor Gerardo Sanchez asked if any of the re-classifications were a demotion.

Ms. Sabori replied that here is one (1) or two (2) demotions but are handled as re-classifications and are based on what was completed on their P+Q. As it was what the employee completed to be submitted to the company, the City wants to avoid picking and choosing and wants to remain neutral.

Mayor Gerardo Sanchez asked how many re-classifications were in total.

Ms. Sabori replied that there were approximately sixty (60) re-classifications for a change in the wording of the person's title.

Mayor Gerardo Sanchez commented that there were several employees that thought they were being demoted because of the title change. He added that it concerns him that the City is trying to find ways to increase salaries and to be fair to everyone. As the City of San Luis has never classified employees properly and has created positions that do not exist, there are no standards. The company hired found positions that existed and placed those employees who were re-classified in them. Mayor Gerardo Sanchez added that it was not fair for employees to compare their salaries without looking at the criteria of education, responsibilities and different criteria the City looks at. Mayor Gerardo Sanchez added that he wants to pay his employees more.

Council Member Mario Buchanan Jr. asked who was recommending the changes.

Mayor Gerardo Sanchez replied that there were no changes and added that the City is looking into ways of giving employees raises.

Mr. Ralph Velez, City Consultant, commented that based on Ms. Keti St. Louis, Finance Director, numbers, the City of San Luis payroll runs \$47,000.00 a day on salary and benefits.

Mayor Gerardo Sanchez commented that residents and people not working for the City of San Luis think their employees are getting paid too much but when looking at different cities, the City of San Luis is getting paid less. Mayor Gerardo Sanchez added that the City is not investing in things that are making money. He added that the City must be proactive and take one (1) step at a time. In addition, Mayor Gerardo Sanchez stated that the City must work and deal with the problems and correct the issues from the past. Mayor Gerardo Sanchez asked staff and Council Members what could be done to make it better for the employees and can the City of San Luis afford to it.

Mr. John Starkey, Zoning Administrator/ Building and Safety Director, stated that his five (5) employees and himself were okay with the salary study.

Mr. Craig Higgins, Chief of Police, concurred with Mr. Starkey's statement.

Ms. Sonia Cornelio, City Clerk, stated that she was in agreement with Mr. Starkey and Chief Higgins. Ms. Cornelio added that her department is all for it and understands that Council has a hard decision to make in regards to the proposed salary changes. She added that it is impossible to make everyone happy.

Mr. Marc Holyfield, Assistant Fire Chief, stated that he has been through different Salary Surveys that have affected employees and something can be done.

Ms. Maria Sabori, Human Resources Senior Analyst, stated that there has been several employees who have approached Human Resources about the status and since it did not go through their morale has gone down as they were hoping for it to go through.

Council Member Gloria Torres commented that when Council Members were approached about the Salary Survey because some of the employees were under paid Council was glad to do it as they wanted employees to have the correct pay. When the Salary Study was made several employees were unsatisfied. She asked why those employees were re-classified when they were comfortable with the position they already hold. Council Member Gloria Torres commented that she had gone to each department and talked to employees and several were not happy. She asked why the re-classification was done when employees are not satisfied.

Mayor Gerardo Sanchez asked how much was spent on the survey.

Ms. Sabori replied approximately \$15,000.00 to \$20,000.00.

Mayor Gerardo Sanchez commented that another solution would be to hire another agency and spend \$15,000.00 to \$20,000.00 to perform another Salary Survey. Mayor Gerardo Sanchez added that when the agency asks employees to fill out the survey they must do it correctly and take it seriously.

Ms. Kay Macuil, City Attorney, commented that employees filled out the forms and when the results came back there was no input from employees, apart from the one (1) on one (1) meetings with Human Resources, and went straight to Council.

Mayor Gerardo Sanchez stated that for a fact, some were being told the survey results and kept saying no, no, no. The moment someone is re-classified it is a demotion in their mindset.

Mr. Eulogio Vera, Public Works Director, stated that the majority of the employees did benefit from the Salary Survey. Mr. Vera added that there are a couple that were impacted in a way that they believe that if they were to filled out the application correctly, due to staffing they would get impacted negatively.

Mr. Hank Green, Fire Chief, commented that the 2006 Salary Survey was done by the same company and their recommendation was not to assign pay when it came to paramedics and in the 2016 survey reflected on assigned pay. While he does agree with assigned pay, as it makes things less complicated in recruitment and promotions. Mr. Green wants to know how the company said one (1) thing and ten (10) years later said something else.

Mr. Ralph Velez, City Consultant, replied that while that did happen the numbers were not the same. While they are making the same recommendations one was never implemented.

Mr. Green continued to say that the City of San Luis cannot deal with bruised egos when it comes to the name change. He added that his personnel and he when looking at the document there are some things that raised questions. One of them being not finding "firefighter" in the 95% of the 2016 Salary Survey.

Ms. Sabori commented that the word "firefighter" was located on grid sixty (60).

Mr. Velez commented that several moving parts to the Salary Survey. Mr. Velez added that because of the employee confidential part, they had to do one on one meetings with the employees and employees had to acknowledge a form that stated that employees were not allowed to talk about the survey in a public meeting and that their titles were going to be discussed. He clarified that it was just a public notice for the individual. He also stated that if there was a title change, that was not explained properly it was on them and salaries cannot be reduced as it is illegal.

Ms. Sabori read the email she received in regards to Directors and Managers. She stated that was their reasoning to changing some Department Directors to Managers.

Ms. Olivia Jenkins, Utilities Director, stated that the problem she sees is that there is no motivation to push forward as they were the same pay as different departments that have different levels of accountability. She commented that it is not the money or the title that affects her, it is just the accountability of her work. Ms. Jenkins added that that when the company did the Salary Surveys ten (10) years ago, representatives from the company were there to go over the PFQs. While there were meetings, they were not very clear, she believes representatives should have been in the meetings to answer questions as Mr. De La Hoya or Ms. Sabori could not answered. Ms. Jenkins added that the company may have the experience but believes the company may have cut corners on the survey.

Ms. Jenny Torres, Community Development Director, stated that her department employees are okay with the Salary Survey. When it comes to her title that was changed from Director to Administrator she benefits from it but it also brought up some concerns.

Ms. Kay Macuil, City Attorney, apologized if they messed up by not including a representative from the company as they were trying to be sensitive. She added that she agrees that the company should have been there.

Mayor Gerardo Sanchez called for a new Salary Study to be done with a different company. Mayor Gerardo Sanchez added that every department would be paying a piece of the total.

Mr. Tadeo De La Hoya, Interim City Manager, asked what would happen if the new survey came back with the same results.

Mayor Gerardo Sanchez replied that the City will pinpoint and be more specific. Mayor Gerardo Sanchez added that if two (2) company's come back with the same results the City has a problem.

Council Member Mario Buchanan Jr. asked supervisors to prepare their employees.

Ms. Sonia Cornelio, City Clerk, asked what if the next study results are less likable and asked if it would take a year to complete.

Mayor Gerardo Sanchez replied that the City would specify with the company on how long they will take but would most likely cost more. He added that if it is unfavorable everything would be taken care of and make it as efficient as possible.

Mr. Tadeo De La Hoya clarified that it took more than a year to complete the Salary Survey because a couple of departments did not agree with it.

Mayor Gerardo Sanchez commented that all departments will agree with the Salary Survey and if any department does not meet the deadlines there will be issues.

Ms. Keti St. Louis, Finance Director, suggested that the correspondence from the company should not be with just Human Resources or Mr. De La Hoya. Any feedback or questions should be received by every department. She added that she has staff that believes some positions are over looked by the company.

Council Member Ruben Walshe commented that one of the reasons the City is having issues right now is because there is no Human Resource Director. Council Member Ruben Walshe suggested that the City hire a Human Resource Director.

Mayor Gerardo Sanchez commented that he expects Ms. Sabori to ask a lot of questions when the new company comes for the employees. Mayor Gerardo Sanchez concluded the Budget Retreat by thanking employees for attending.

### **3. Adjournment**

**MOTION:** Council Member Mario Buchanan Jr./ Council Member Ruben Walshe to adjourn the Budget Retreat on April 16, 2016 at approximately 5:17 p.m. Motion passed unanimously.

**MINUTES**  
**Work Session**  
**San Luis City Council**  
**San Luis Council Chambers**  
**1090 E. Union Street**  
**April 20, 2016**  
**6:30 p.m.**

**1. CALL TO ORDER/ROLL CALL**

Mayor Gerardo Sanchez called the Work Session to order at approximately 6:36 p.m.

**PRESENT:** Mayor Gerardo Sanchez  
Vice-Mayor Matias Rosales  
Council Member Ruben Walshe  
Council Member Gloria Torres  
Council Member Maria Cecilia Ramos  
Council Member Africa Luna-Carrasco  
Council Member Mario Buchanan Jr.

**OTHERS PRESENT:** Tadeo A. De La Hoya, Interim City Manager  
Sonia Cornelio, City Clerk  
Kay Macuil, City Attorney  
Aracely De La Hoya, Senior Services Director  
Christine Hagen, Management Analyst  
Craig Higgins, Chief of Police  
Derek Dueñas, Acting IT Manager  
Eulogio Vera, Public Works Director  
Jennifer Cisneros, Acting Parks and Recreation Director  
Jenny Torres, Community Development Director  
John Starkey, Building Safety Director  
Johnathan Dumadag, IT Technician  
Joselyn Medina, Assistant to Mayor and Council/PIO  
Katie St. Louis, Finance Director  
Manuel Rojas, Assistant Public Works Director  
Maria Sabori, HR Senior Analyst  
Olivia Jenkins, Utilities Director  
Ralph Velez, City Consultant  
Richard Bauermann, Fire Department  
Yolanda Dueñas, Fleet Services/Facilities Manager

Nieves Riedel, Riedel Construction  
Marc Holyfield, Assistant Fire Chief  
Guillermina Fuentes, Resident  
Eduardo Garcia, Factor Sales, Inc.  
Marco A. "Tony" Reyes, Comite de Bienestar  
Gary Black, Comite de Bienestar

## **2. AGENDA ITEMS:**

### **2.A. Discussion on any and all matters regarding the proposed Development Agreement with Riedel Construction, Inc. and Rezoning Case No. 2016-065 as both pertain to proposed subdivision known as Las Quintas De San Luis II. (John Starkey, Zoning Administrator)**

Mr. John Starkey, Zoning Administrator, informed that this is the rezoning of a property currently zoned at Rural Area Residential (RA-10) to Medium Density Residential (R1-6) for the purpose of building a single home subdivision. The property is located south of County 22nd Street between the East Main Canal and Las Quinta de San Luis Subdivision. The lots will be greater than 6,000 feet. He stated that this went to the Planning and Zoning Commission in 2014, then it was withdrawn before the City Council could take action. It has been brought again to the Planning and Zoning Commission on April 12, 2016 and they have recommended approval of the request with the condition that the developer must negotiate a Development Agreement with the City of San Luis. Mr. Starkey informed that the Development Agreement presented in the Council's Agenda packet was the one prepared a year ago and staff is still in the negotiation stage. He informed that one of the changes that the developer would like to make is that two story homes be allowed, as the developer has received requests for that type of homes. Mr. Starkey presented Mayor and Council with the maps pointing out the location of one story and two story homes. He indicated that there will be no two-story homes from lots 1-37, which are the lots that would back on the existing subdivision.

Mayor Gerardo Sanchez commented that his concern was the two-story homes as he received calls regarding this. He stated that now that is clarified that single story homes will be restricted in some of the lots will relief any future conflicts.

Council Member Ruben Walshe stated that this new development is much needed in San Luis as there are no available lots in the other subdivisions. He mentioned that Council should support any projects that comes before the City Council.

Vice Mayor Matias Rosales asked what are the other items being discussed in the Development Agreement.

Mr. John Starkey replied that one of the items discussed is the improvements of County 22<sup>nd</sup> Street, which will include street lights along County 22<sup>nd</sup> Street and Sidewinder Road. He added that the developer and the City will share the cost of the lights on Sidewinder Road and the developer will pay in full for the ones on County 22<sup>nd</sup> Street. He stated that the improvement district will also be required.

Mayor Gerardo Sanchez asked if staff has identified any possible risks when looking at the plat.

Mr. Starkey replied that the only risk was County 22<sup>nd</sup> Street visibility.

Mr. Eulogio Vera, Public Works Director, mentioned that plans have been reviewed for the layout, and they will be reviewed in detail once the design is complete. He added that the other thing to be reviewed will be the sloping between parcels.

Vice-Mayor Matias Rosales asked if the developer will be responsible for developing the retention basin.

Mr. Starkey replied that improvements in the retention basin will be done by the City from impact fees collected from each house.

Council Member Mario Buchanan asked Mr. Starkey to make sure that the developer complies with the Development Agreement and that a traffic study is done.

Mr. Starkey replied that the Development Agreement will be brought before Council for approval.

Mr. Vera mentioned that the traffic analysis of the area was done and the traffic study was not needed. He added that there is an option of a traffic study for the final design, and this study is needed for turning lanes as well as to access the development. He mentioned that if this is required, then it will be done at intersection of County 22<sup>nd</sup>

Street and the main road into the subdivision. Furthermore, he added that the study should not take long if staff is to pursue this option.

A representative from Edais Engineering informed that the development will consist of 112 residential lots located along the east main canal, the main access will be on County 22<sup>nd</sup> Street and the secondary access to the subdivision will be on Torres Street. She added that the intention is to comply with all City regulations.

Mayor Gerardo Sanchez asked if there will be a problem if the City requests not to build two-story homes next to the current subdivision.

Mrs. Nieves Riedel, Riedel Construction, replied that the reason the original Development Agreement was changed is that contractors have asked not to be restricted. She mentioned that with this request she is trying to accommodate contractors that bring economic development to the City. She stated that her concern is that if a traffic study is performed that will take several months and she would like to start with the project as soon as possible. Mrs. Riedel thanked Mayor and Council for taking this project into consideration. She mentioned that it is her best interest to do things right and added that she and Mr. Najah Edais, Project Engineer, will work in conjunction with the City.

**2.B. Discussion on any and all matters regarding Rezoning Case No. 2016-066 for proposed subdivision known as Bienestar 9A Phase 2. (John Starkey, Zoning Administrator)**

Mr. John Starkey, Zoning Administrator, informed that this subdivision was approved in 2008, however because of the housing, it was not built and now they are bringing it back to Council. This time they are requesting to rezone approximately 29 acres from Medium-High Density (R-2) to Medium Density Residential (R1-6) so that these lots be at least 6,000 square feet. He informed that this subdivision will consist of approximately 138 new home sites.

Mayor Gerardo Sanchez asked if there is an existing Development Agreement for this subdivision.

Ms. Kay Marion Macuil, City Attorney, replied that staff did not find a Development Agreement, but did find an ordinance that puts conditions to the subdivision.

Mr. John Starkey mentioned that it will be a great idea to require additional access to this subdivision as the only access is through Avenue F

Mayor Gerardo Sanchez asked Mr. Starkey to please look into the idea of the new access road for that subdivision.

Mr. Marco A. Reyes, Comite de Bienestar Executive Director, informed that this is not a new subdivision, this is a subdivision that has already be platted and now it has to be changed because of the changes in the lot size regulations. The land in discussion is included in the Development Agreement for the whole subdivision of approximately 400 acres. He informed that this subdivision is an 80 acre subdivision that was split in two (2) sections, this is the reason that there is no Development Agreement for this particular subdivision. Mr. Reyes thanked Mayor and Council for giving him the opportunity to present his new subdivision.

**2.C. Discussion on any and all matters regarding a futsal soccer field at Joe Orduño Park. (Jennifer Cisneros, Acting Parks and Recreation Director)**

Ms. Jennifer Cisneros, Acting Parks and Recreation Director, informed that this item was approved by Council, but the Cooperative Agreement was not included with the Agenda the day it was approved for this reason staff cannot move forward with the purchase. She added that staff is still waiting for the Agreement. She mentioned she would like to do some research as to what will be the cost to put up grass instead of artificial turf.

Mayor Gerardo Sanchez commented that staff has always focused on lowest bidders for projects, but there are times that lowest bidders do not provide one with the best quality. He stated that if staff goes with the artificial turf, to make sure that the City is provided with the best quality and product.

Council Member Ruben Walshe stated that he did some research online and found that the company mentioned when item was approved, is the best one to provide this product, as they do NFL football fields, training fields, etc.

Vice-Mayor Matias Rosales mentioned that if the information is available for the next Regular Council meeting to present it there for approval, but does not want this item on another Work Session.

Ms. Cisneros stated that she would like the company to come see the site before they do any work.

**2.D. Discussion on any and all matters regarding Resolution No. 1143. A resolution of the Mayor and City Council of the City of San Luis, Arizona, County of Yuma, validating the results of a competitive bid for an on-call provider of the City Civil Engineering Services and authorizing the appointment of six civil engineering firms to a list from which Civil Engineering firms will be drawn on as needed basis to provide needed professional services. (Jenny Torres, Community Development Director)**

Ms. Jenny Torres, Community Development Director, informed that approximately six (6) years ago, the City Council passed Resolution No. 927 appointing six (6) civic engineering firms to provide their services to the City. She mentioned that this resolution expired on March 2016. She added that staff developed and properly notice in the newspaper a Request for Qualifications (RFQ). She informed that a committee was formed to evaluate the proposals. There were eight (8) RFQ's submitted, the evaluation committee is recommending six (6) firms to be placed on the list of on-call engineering services for the City to draw for the next five (5) years. Furthermore, she added that she received a call from one of the engineering firms that was not selected and they are requesting that the City allows the eight (8) firms be included in the resolution. They believe that they have the capability to provide services to the City. Ms. Torres informed that staff is recommending the following firms: Dahl, Robins and Associates, James Davey and Associates, CORE Engineering Group, PACE Advance Water Engineering, Nicklaus Engineering and Vega and Vega Engineering. The two that were not selected are Jacobson Engineering and Development and, Design and Engineering. She added that it is up to Council to choose as many as deemed necessary. She mentioned that staff would like to have a list of engineering firms from where the City can choose from based on the project.

Mayor Gerardo Sanchez asked what the reason was for selecting six (6) engineering firms.

Mr. John Starkey, Zoning Administrator, replied that the reason was that previous Councils decided to go with all the six (6) engineers that submitted their RFQ at that time; they wanted to have other options to choose from.

Council Member Ruben Walshe suggested hiring all eight (8) engineers and not limit staff. He mentioned that each engineer has their own expertise.

**2.E. Discussion on any and all matters regarding Resolution No. 1144. A resolution of the Mayor and City Council of the City of San Luis, Arizona, providing for a Call of Election for the 2016 Primary and General Elections, designating the election dates and purpose, designating the deadline and location for candidates to file Nomination Petitions and designating the deadline for voter registration. (Sonia Cornelio, City Clerk)**

Ms. Sonia Cornelio, City Clerk, informed that this resolution is for the upcoming Primary and General elections for 2016, designating the election dates and purpose, designating deadline and location for candidates to file Nomination Petitions and designating the deadline for voter registration. She added that the publication of Call of Elections is a good way to inform voters about the election and alert candidates for filing dates. She mentioned that it has been customary to publish a Call of Elections for four (4) consecutive days in a daily newspaper at least 100 days prior to the Primary Elections. Ms. Cornelio informed that the City will be doing the Call of Election 125 days prior to the election, the reason is that the publication will be done before the candidate packet are available for distribution on May 2, 2016. If it is done 100 days prior to the election, then Call of Election will be done after the candidate packet are distributed.

**3. DISCUSSION ITEM(S):**

**3.A. Discussion on any and all matters regarding Sonórtica DENT ALL GROUP services. (Dr. Carlos Sanchez)**

Ms. Lourdes Salas, Sonortica DENT ALL GROUP Services (Sonortica), introduced Dr. Carlos Sanchez.

Dr. Carlos Sanchez, Sonortica DENT ALL Group Services, informed that during a previous presentation he was able to introduce the services provided at Sonortica DENT ALL Group. He stated that the reason to have Sonortica's services in the City's dental insurance is that Sonortica provides all services and dental specialties. He informed that Sonortica is located in Mexico and for this reason the prices are very reasonable and provide good quality service. Furthermore, he added that Sonortica is the only dental clinic certified/accredited by the American Dental Association. Dr. Sanchez stated that Sonortica is a corporation that pays state and federal taxes and contribute to the development of San Luis, Arizona. He informed that Sonortica manages a database that provides dental history when required. This is also one of the reasons Sonortica is offering their services to the City of San Luis.

Mayor Gerardo Sanchez stated that he asked that this item be brought before Council for further discussion on Sonortica's services. He mentioned that Sonortica's image is very positive and the majority of employees have been a Sonortica patient and there are some employees that are still receiving treatment there. He added that staff will have to review the contract that was signed and approved, to see if there is legal requirement clauses.

Council Member Gloria Torres commented that there are employees that are still under treatment at Sonortica and that will have to go to a different dentist in order to finish their treatment.

Council Member Mario Buchanan Jr. stated that the most important thing is that the employees are happy with Sonortica's service. He mentioned that it will be a good idea to hear from employees to obtain their feedback.

Council Member Ruben Walshe stated that he agrees with Council Member Mario Buchanan Jr. and added that he has heard good feedback from employees. He mentioned that the City is thriving to provide the best services to its employees. Mr. Tadeo A. De La Hoya, Interim City Manager, asked Dr. Sanchez if he has a contract or if he is in contact with Mayo Clinic.

Dr. Sanchez replied that Sonortica has been in contact with Mayo Clinic in previous processes, as they are the ones that review and evaluate the procedures, but there is no contract with Mayo Clinic. He mentioned that Sonortica will be able to work with Mayo Clinic if they are contracted with a company that is already contracted with Mayo Clinic.

Mr. De la Hoya asked if the certification mentioned is the same as the Asociacion Mexicana de Orthodoncia.

Dr. Sanchez replied that the Asociacion Mexicana de Orthodoncia is different to the American Dental Association which is in charge of evaluating that the premises meet their quality standards and that the services meet a high quality service; this certification is done every year. He informed that Sonortica also has the certification of the Asociacion Mexicana de Orthodoncia.

Mr. De La Hoya asked if Sonortica is currently contracted with Southwest Services Administrators. He also asked if in the United States, Sonortica is registered as a corporation.

Dr. Sanchez replied that Sonortica is currently contracted with Southwest Services Administrators and they have their own pricing list. He added that Sonortica is registered as a corporation.

Mr. De La Hoya recommended Dr. Sanchez to get in contact with SIARMED to see if they are willing to work with Sonortica, as they are part of the City of San Luis Medical Panel and they are the third party administrator.

Mayor Gerardo Sanchez stated that Council will be the one making the decision and no decision will be made during the Work Session. He added that Council will evaluate and discuss this item. He mentioned that this item needs further discussion and would like to hear from City employees and would like to see what the legal requirements are.

#### **4. Adjournment**

**MOTION:** Council Member Mario Buchanan Jr./Council Member Gloria Torres to adjourn the meeting at approximately 7:50 p.m. Motion passed unanimously.

**MINUTES**  
**Regular Meeting**  
**San Luis City Council**  
**San Luis Council Chambers**  
**1090 E. Union Street**  
**San Luis, AZ 85349**  
**April 27, 2016**  
**7:00 P.M.**

1. **CALL TO ORDER** Mayor Gerardo Sanchez called the Regular City Council meeting to order at approximately 7:05 p.m.

**ROLL CALL**

**PRESENT:** Mayor Gerardo Sanchez  
Vice-Mayor Matias Rosales  
Council Member Mario Buchanan Jr.  
Council Member Africa Luna-Carrasco  
Council Member Maria Cecilia Ramos  
Council Member Gloria Torres  
Council Member Ruben Walshe

**OTHERS PRESENT:** Tadeo De La Hoya, Interim City Manager  
Sonia Cornelio, City Clerk  
Adan Garcia, Police Department  
Alan Guevara, Police Department  
Alfredo Campa, Police Department  
Craig Higgins, Chief of Police  
Derek Dueñas, I.T. Manager  
Edgar Carbajal, Human Resources Specialist  
Emanuel Botello, Police Department  
Ernesto Cardenas, Police Department  
Eulogio Vera, Public Works Director  
Janet Taylor, Administrative Assistant  
Jennifer Cisneros, Acting Parks and Recreation Director  
Jenny Torres, Community Development Director  
John Starkey, Building Safety Director/ Zoning Administrator  
John Carrillo, Police Department  
Johnathan Dumadag, I.T. Technician  
Jose Guzman, Assistant Planner  
Jose Santiago, Parks Maintenance Technician  
Jose Vasquez, Police Department  
Joselyn Medina, PIO/Assistant to Council  
Juan De Los Reyes, Police Department  
Kay Macuil, City Attorney  
Katie St. Louis, Finance Director

Lizeth Laguna, Police Department  
Marco Santana, Police Department  
Maria Sabori, H.R. Senior Analyst  
Melina Torres, Police Department  
Miguel Alvarez, Police Department  
Olivia Jenkins, Utilities Director  
Ric Bauermann, Fire Department  
Roula Encinas, Accountant  
Stephanie Rios, Police Department  
Victor Lopez, Parks Maintenance Technician  
Yolanda Dueñas, Fleet/Facilities Manager  
Cesar Neyoy, Reporter  
Francisca Guzman, Translator  
Guillermina Fuentes, Resident  
Tony Reyes Sr., Yuma County Supervisor  
Gary Black, Comite De Bienestar  
Veaney Vega, Vega and Vega Engineering  
Martin Porchas, Visitor  
Lucky Hoyos, Visitor

## **2. PLEDGE OF ALLEGIANCE**

The pledge of allegiance was led by Council Member Maria Cecilia Ramos.

## **3. INVOCATION**

The invocation was led by a visitor.

## **4. PRESENTATIONS**

### **4. A. Introduction of recently hired employees to City Council and members of the public. Employees hired from January through March 2016. (Tadeo A. De La Hoya, Interim City Manager)**

Mr. Tadeo De La Hoya, Interim City Manager, introduced the employees hired in the last quarter by name and department.

Mayor Gerardo Sanchez welcomed the new employees on behalf of Council.

### **4. B. Presentation and recognition of employees by the Employee Recognition and Awards Program for their outstanding work with the City of San Luis. (Omar Heredia, Programs and Training Coordinator)**

Ms. Maria Sabori, Human Resources Senior Analysts, presented employees with years of service awards and ERAP awards.

**4. C. Presentation about the Yuma 50, a community support mechanism for Yuma's Military. (Ken Rosevear, Chairman of the Board of the Yuma 50)**

Mr. Ken Rosevear, Chairman of the Yuma 50, provided information about Yuma 50. Mr. Rosevear also asked Mayor and Council for a Resolution in support of Yuma 50.

Mayor Gerardo Sanchez asked how fast the Resolution is needed. He too thanked Mr. Rosevear.

Mr. Rosevear replied that in the next two (2) weeks.

**5. CONSENT AGENDA**

**5. A. Minutes of**

- Regular Council meeting held March 9, 2016

**5. B. Disbursements from April 4, 2016 through April 15, 2016**

Total Disbursements \$676,905.33

(Six Hundred Seventy-Six Thousand, Nine Hundred Five Dollars and Thirty-Three Cents)

**5. C. Discussion and possible action on any and all matters regarding Resolution No. 1143. A resolution of the Mayor and City Council of the City of San Luis, Arizona, County of Yuma, validating the results of a competitive bid for an on-call provider of the City Civil Engineering Services and authorizing the appointment of eight (8) civil engineering firms to a list from which Civil Engineering firms will be drawn on an as-needed basis to provide needed professional services. (Jenny Torres, Community Development Director)**

**5. D. Discussion and possible action on any and all matters regarding Resolution No. 1144. A resolution of the Mayor and City Council of the City of San Luis, Arizona, providing for a Call of Election for the 2016 Primary and General Elections, designating the election dates and purpose, designating the deadline and location for candidates to file Nomination Petitions and designating the deadline for voter registration. (Sonia Cornelio, City Clerk)**

**MOTION:** Council Member Gloria Torres/ Council Member Ruben Walshe to approve the Consent Agenda as presented. Motion passed unanimously.

**6. DISCUSSION AND POSSIBLE ACTION ITEMS**

**6. A. Discussion on any and all matters regarding a futsal soccer field at Joe Orduño Park and options for regular soccer and other parks. (Jennifer Cisneros, Acting Parks and Recreation Director)**

Ms. Jennifer Cisneros, Acting Parks and Recreation Director, stated that the cooperative agreement was provided to the Parks and Recreation Department. Ms. Cisneros stated that a quote will be received on Friday, April 29, 2016, from a local contractor.

Mayor Gerardo Sanchez stated that they want the project to be done this Fiscal Year.

Ms. Kay Macuil, City Attorney, stated that when it was approved on April 14, 2016 as a piggy-back but no contract was presented. Ms. Macuil added that as all documentation is present the motion on April 14, 2016 is legal and appropriate.

**6. B. Discussion and possible action awarding bid and approval of entering into a contract with DPE Construction for constructing Phase I of the 4<sup>th</sup> Avenue and 1<sup>st</sup> Avenue and Juan Sanchez Boulevard Roadway Improvements Project. (Eulogio Vera, Public Works Director)**

Mr. Eulogio Vera, Public Works Director, stated that The City of San Luis received bids for the construction of Phase I of the 4<sup>th</sup> Avenue and 1<sup>st</sup> Avenue and Juan Sanchez Boulevard Roadway Improvements Projects. Two (2) weeks ago bids were submitted and DPE of Yuma was the lowest with a total of \$428,918.60. Mr. Vera added that funds will be needed from Fiscal Year 2017 for the project to be completed. He added that DPE has a project schedule that they would be following to finish the project in a appropriate manner of time.

**MOTION:** Council Member Gloria Torres/ Council Member Mario Buchanan Jr. to accept the lowest responsive bid by DPE for construction of Phase I of the Juan Sanchez Boulevard Roadway Improvements as presented. Motion passed unanimously.

**6. C. Discussion and possible action on any and all matters regarding the renewal of the AgendaQuick Software Service Agreement between the City of San Luis and Destiny Software Inc. (Sonia Cornelio, City Clerk)**

Ms. Sonia Cornelio, City Clerk, stated that the agreement is to renew the contract with AgendaQuick Software that is being used by the City Clerk's office and the Planning and Zoning Commission for the preparation of the agenda.

**MOTION:** Council Member Mario Buchanan Jr./ Council Member Africa Luna-Carrasco to approve the subscription contract with Destiny Software, Inc. as presented and approve the change of renewal date to coincide with the start of the City's Fiscal Year July 1. Motion passed unanimously.

**6. D. Public Hearing followed by discussion and possible action on any and all matters regarding Resolution No. 1142. A resolution of the Mayor and Council of the City of San Luis, Arizona approving and adopting the Arizona Department of Transportation Federal Transit Assistance Disadvantaged Business Enterprises Program Plan. (Kay Marion Macuil, City Attorney)**

**A. Open Public Hearing**

**MOTION:** Council Member Mario Buchanan Jr./ Council Member Africa Luna-Carrasco to open Public Hearing. Motion passed unanimously.

Ms. Kay Marion Macuil, City Attorney, stated that the adoption of the Disadvantage Business Enterprise Program Plan of ADOT is for the use of funds for the bus grant if and when it is granted. Ms. Macuil also stated that the plan has to be adopted because the funds have to follow the plan with ADOT.

**B. Close Public Hearing**

**MOTION:** Council Member Mario Buchanan Jr./ Council Member Ruben Walshe to close Public Hearing. Motion passed unanimously.

**C. Action on Resolution No. 1142**

**MOTION:** Council Member Mario Buchanan Jr./ Council Member Maria Cecilia Ramos to approve and adopt Resolution No. 1142. Motion passed unanimously.

**6. E. Discussion and possible action on any and all matters regarding Second Reading of Ordinance No. 349. An ordinance of the Mayor and City Council of the City of San Luis, Arizona, enacting and adopting a supplement to the Code of Ordinances for the City of San Luis, Arizona; repealing any conflicting provisions; and providing for severability. (Kay Marion Macuil, City Attorney)**

Ms. Kay Macuil, City Attorney, stated that Ordinance No. 349 is to add the ordinances that have been codified to the City Code book.

**A. Approval of Second Reading of Ordinance No. 349 by title only**

**MOTION:** Vice-Mayor Matias Rosales/ Council Member Mario Buchanan Jr. to approve the Second Reading of Ordinance No. 349 by title only. Motion passed unanimously.

Ms. Sonia Cornelio, City Clerk, read Ordinance No. 349 by title only.

**B. Approval and adoption of Ordinance No. 349**

**MOTION:** Vice-mayor Matias Rosales/ Council Member Mario Buchanan Jr. to approve and adopt Ordinance No. 349. Motion passed unanimously.

**6. F. Discussion and possible action on any and all matters regarding Resolution No. 1145. A resolution of the Mayor and Council of the City of San Luis, Arizona approving Las Quintas de San Luis II Development Agreement between the City of San Luis, Arizona and Riedel Holdings, L.L.C. (John Starkey, Zoning Administrator)**

Mr. John Starkey, Zoning Administrator, stated that in the review of the Development Agreement with Riedel Holding L.L.C. a few sections needed to be corrected for it to read more clearly. Mr. Starkey requested the item be continued at the next Regular Council Meeting.

Ms. Kay Macuil, City Attorney, clarified that the Resolution will be presented first followed by the changes to the Zoning Ordinances.

Council Member Mario Buchanan Jr. asked if in the corrections Mr. Starkey would be including the traffic study.

Mr. Starkey replied that between the three (3) engineers they would be able to resolve any traffic issues that may arise in the entrance of the subdivision. He added that a traffic study would not be necessary until all corrections are made by the engineers.

Mr. Eulogio Vera, Public Works Director, clarified that the City of San Luis had adopted Yuma County Standards that require a traffic study to be done or the developers include the turning lanes when required. Mr. Vera added that they would be added as part of the improvements.

Mayor Gerardo Sanchez asked Mr. Starkey to have it included in the agreement.

**MOTION:** Vice-Mayor Matias Rosales/ Council Member Mario Buchanan Jr. approve to continue item to the next Regular Council Meeting held on May 11, 2016. Motion passed unanimously.

**6. G. Public Hearing followed by discussion and possible action on any and all matters regarding Rezoning Case No. 2016-065, and First Reading of Ordinance No. 351. An ordinance of the Mayor and Council of the City of San Luis, Arizona, amending the official zoning map of the City of San Luis by changing the zoning**

**classification of approximately 28.76 acres located south of County 22<sup>nd</sup> Street between the East Main Canal and Las Quintas de San Luis Subdivision from Rural Area Residential (RA-10) to Medium Density Residential (R1-6); repealing any conflicting provisions; and providing for severability. (John Starkey, Zoning Administrator)**

#### **A. Open Public Hearing**

**MOTION:** Vice-Mayor Matias Rosales/ Council Member Ruben Walshe to open Public Hearing. Motion passed unanimously.

Mr. John Starkey, Zoning Administrator, stated that a request was made by Edais Engineering on behalf of Nieves Ridel owner of Riedel Holdings, L.L.C. to rezone 27.58 acres from Rural Area Residential (RA-10) to Medium Density Residential (R1-6). Mr. Starkey stated that an updated agreement will be presented before the Second Reading of Ordinance No. 351 is done.

#### **B. Close Public Hearing**

**MOTION:** Council Member Mario Buchanan Jr./ Council Member Africa Luna-Carrasco to close Public Hearing. Motion passed unanimously.

#### **C. Action on First Reading of Ordinance No. 351 by title only**

**MOTION:** Council Member Africa Luna Carrasco/ Vice-Mayor Matias Rosales to approve First Reading of Ordinance No. 351 by title only. Motion passed unanimously.

Ms. Sonia Cornelio, City Clerk, read Ordinance No. 351 by title only.

**6. H. Public Hearing followed by discussion and possible action on any and all matters regarding Rezoning Case No. 2016-006, and First Reading of Ordinance No. 352. An ordinance of the Mayor and Council of the City of San Luis, Arizona, amending the Official Zoning map of the City of San Luis by changing the zoning classification of approximately 29 acres located on the Southwest corner of Avenue E ½ and County 23 ½ Street from Medium-High Density (R-2) to Medium Density Residential (R1-6); repealing any conflicting provisions; and providing for severability. (John Starkey, Zoning Administrator)**

#### **A. Open Public Hearing**

**MOTION:** Council Member Mario Buchanan Jr./ Council Member Africa Luna Carrasco to open Public Hearing. Motion passed unanimously.

Mr. John Starkey, Zoning Administrator, stated that the request was submitted by Vega & Vega Engineering, PLC on behalf of Comite De Bienestar to rezone twenty-nine (29) acres of land from the Southwest corner of Avenue E 1/2 and County 23 1/2. Mr. Starkey added that they are building the second phase of the existing Bienestar subdivision that was approved back in 2007 and only Phase I was developed, Phase II will be developed following the new regulations.

### **B. Close Public Hearing**

**MOTION:** Council Member Mario Buchanan Jr./ Council Member Africa Luna-Carrasco to close Public Hearing. Motion passed unanimously.

### **C. Action on First Reading of Ordinance No. 352 by title only**

**MOTION:** Vice-Mayor Matias Rosales/ Council Member Africa Luna-Carrasco to approve the First Reading of Ordinance No. 352 by title only. Motion passed unanimously.

Ms. Sonia Cornelio, City Clerk, read Ordinance No. 352 by title only.

## **7. SUMMARY OF CURRENT EVENTS**

Council Member Ruben Walshe stated that Council Member Maria Cecilia Ramos, Council Member Gloria Torres and himself attended the Día del Niño celebration on April 27, 2016 and stated that it was a great event.

Mayor Gerardo Sanchez stated that he attended the ribbon cutting for the City's first water filtration system on April 27, 2016. Mayor Sanchez also reported that Vice Mayor Matias Rosales, Mayor Enrique Reyna of Somerton, Mayor Douglas Nicholls of Yuma, and himself would be heading to Mexico City on May 18, 2016 to discuss the issues with Port of Entry I and Port of Entry II.

Council Member Maria Cecilia Ramos stated that on April 25th and 26th she attended the Arizona Mexico Town Hall and commented that she is proud of the relationship that is continuing to grow between the City and Mexico.

## **8. CALL TO THE PUBLIC**

Mayor Gerardo Sanchez opened Call to The Public after the Consent Agenda was presented.

Mr. Martin Porchas, 457 East Patricia Street Somerton, Arizona, stated that The City of Somerton is greatly thankful for their ongoing support. Mr. Porchas hopes to see the support to the City of Somerton continue.

## **9. EXECUTIVE SESSION**

**MOTION:** Vice-Mayor Matias Rosales/ Council Member Mario Buchanan Jr. to go into Executive Session at approximately 9:05 p.m. Motion passed unanimously.

**9. A. Discussion and possible action to hold an executive session pursuant to A.R.S. §38-431.03(A)(3) for discussion or consultation for legal advice with the City Attorney or attorneys and A.R.S. §38-431.03(A)(4) for discussion or consultation with the City Attorney or attorneys in order to consider its position and instruct its attorneys regarding the City's position regarding contracts that are the subject of negotiations relating to the proposals of Sonórtica Dent-ALL Group to be a dental health provider for the City. (Kay Marion Macuil, City Attorney)**

## **10. ADJOURNMENT**

**MOTION:** Vice-Mayor Matias Rosales/ Council Member Mario Buchanan Jr. to adjourn the Regular Council Meeting at approximately 9:05 p.m. Motion passed unanimously.



## AGENDA ITEM REVIEW FORM

**Regular City Council Meeting**

**4. B.**

Meeting Date: 06/08/2016

---

Summary

**DISBURSEMENTS FROM MAY 16, 2016 THROUGH MAY 27, 2016**

Total Disbursements \$722,289.53

(Seven Hundred Twenty-Two Thousand, Two Hundred Eighty-Nine Dollars and Fifty-Three Cents)

---

Attachments

Disbursements 6/8/2016

---



# City of San Luis

## Finance Department

### COUNCIL MEETING June 8, 2016 Disbursement Reports from 5/16/2016 to 5/27/2016

<u>Bank Accounts</u>	<u>Check Date</u>	<u>Amount</u>	<u>Schedule</u>
Accounts Payable Check Account	5/17/2016	\$ 3,192.81	Schedule A
Accounts Payable Check Account	5/18/2016	\$ 35,779.17	Schedule B
Accounts Payable Check Account	5/19/2016	\$ 49,095.60	Schedule C
Accounts Payable Check Account	5/19/2016	\$ 166,505.40	Schedule D
Accounts Payable Check Account	5/19/2016	\$ 45,523.89	Schedule E
Payroll Check Account	5/19/2016	\$ 241,961.99	Schedule F
Payroll Check Account	5/19/2016	\$ 4,381.34	Schedule G
Accounts Payable Check Account	5/24/2016	\$ 495.00	Schedule H
Accounts Payable Check Account	5/24/2016	\$ 1,509.35	Schedule I
Accounts Payable Check Account	5/26/2016	\$ 168,211.35	Schedule J
Accounts Payable Check Account	5/26/2016	\$ 4,770.63	Schedule K
Accounts Payable Check Account	5/26/2016	\$ 863.00	Schedule L

**Total Disbursements:     \$     722,289.53**

Please contact Ms. St. Louis prior to the meeting if additional information is needed.

Prepared by Angelica V. Castro: Angelica V. Castro

Verified by Finance Director: C Cortes <sup>by KS</sup> <sub>05-31-2016</sub>

For Council approval on: \_\_\_\_\_

Mayor: \_\_\_\_\_

Council: \_\_\_\_\_

**RECEIVED**  
 2016 MAY 31 PM 4:06  
 CITY OF SAN LUIS  
 OFFICE OF THE CITY CLERK

City of San Luis  
**Payment Batch Register**  
 Bank Account: 1BYPAYABLE - 1st BY Accounts Payable  
 Batch Date: 05/17/2016

Schedule A

Type	Date	Number	Source	Payee Name	EFT Bank/Account	Transaction Amount
<b>Bank Account: 1BYPAYABLE - 1st BY Accounts Payable</b>						
Check	05/17/2016	75291	Accounts Payable	O'REILLY AUTO PARTS		3,192.81
	Invoice		Date	Description		Amount
	2771-360824		02/17/2016	PURCHASE OF GLOVES FOR CITY SHOP		84.71
	2771-369619		04/13/2016	PURCHASE OF EQUIPMENT FOR CITY SHOP		376.71
	2771-366406		03/23/2016	PARKS 0377 EE328		2.42
	2771-371882		04/28/2016	SENIOR CENTER 5332 EE610		195.25
	2771-372017		04/29/2016	HWY USER 4837 EE328		79.29
	2771-371908		04/28/2016	SOLID WASTE 0487 EE610		234.84
	2771-372063		04/29/2016	VWV 9055 EE610		142.28
	2771-368866		04/08/2016	PD 2917 EE328		150.72
	2771-368506		04/06/2016	VWV 5806 EE610		57.57
	2771-369258		04/11/2016	PARKS 9933 EE328		164.12
	2771-368500		04/06/2016	VWV 5806 EE610		79.62
	2771-368507		04/06/2016	CREDIT		(79.62)
	2771-368344		04/05/2016	HWY 3580 EE610		181.19
	2771-368508		04/06/2016	CREDIT		(50.45)
	2771-368243		04/04/2016	PD 8661 EE610		167.13
	2771-370338		04/18/2016	PD 1605 EE328		3.00
	2771-369285		04/11/2016	HWY 8098 EE610		47.78
	2771-370500		04/19/2016	VWV 4835 EE610		214.56
	2771-370987		04/22/2016	PD 6226 EE735		20.70
	2771-371768		04/27/2016	BUILDING SAFETY 2115 EE610		5.91
	2771-371688		04/27/2016	FIRE 8313 EE610		7.28
	2771-369287		04/11/2016	HWY 2395 EE610		40.90
	2771-371545		04/26/2016	VWV 4835 EE610		168.45
	2771-371611		04/26/2016	SW 3270 EE610		234.84
	2771-370858		04/21/2016	FIRE 8313 EE735		653.19
	2771-371687		04/27/2016	PD 5501 EE610		4.09
	2771-371021		04/22/2016	PD 0566 EE735		6.33

1BYPAYABLE 1st BY Accounts Payable Totals:

Transactions: 1

\$3,192.81

Checks:

1

\$3,192.81

Prepared By:  
*Maggie Dominguez*  
 Date: *Maggie D* 5/17/16

User: Margarita Dominguez

Pages: 1 of 1

*C* 5/17/2016 8:15:30 AM

City of San Luis  
**Payment Batch Register**  
 Bank Account: 1BYPAYABLE - 1st BY Accounts Payable  
 Batch Date: 05/18/2016

Type	Date	Number	Source	Payee Name	EFT Bank/Account	Transaction Amount
<b>Bank Account: 1BYPAYABLE - 1st BY Accounts Payable</b>						
Check	05/18/2016	75292	Accounts Payable	ARIZONA DEPARTMENT OF REVENUE / TPT		32,643.80
		Invoice	Date	Description		Amount
		APRIL 2016	05/18/2016	SALES TAX - APRIL 2016		32,643.80
Check	05/18/2016	75293	Accounts Payable	AUTOZONE STORES, INC		3,135.37
		Invoice	Date	Description		Amount
		2756279087	04/09/2016	PURCHASE OF BATTERY FOR CORDLESS DRILLS FOR CITY SHOP		239.89
		2756283756	04/13/2016	PURCHASE OF TOOLS FOR CITY SHOP		66.43
		2756294546	04/22/2016	PURCHASE OF HYDRAULIC OIL FOR SOLID WASTE DEPT VIN# 0059		97.25
		2756273771	04/05/2016	WW 5806 EE180		17.11
		2756276295	04/07/2016	PD 8859 EE180		8.93
		2756275352	04/06/2016	HWY 1849 EE180		157.20
		2756277519	04/08/2016	FLEET SERVICES 1172 EE180		314.40
		2756268646	04/01/2016	WATER 4174 EE180		29.59
		2756275182	04/06/2016	SW 3796 EE180		57.14
		2756281337	04/11/2016	WATER 2933 EE180		16.36
		2756281220	04/11/2016	PARKS 9933 EE180		92.66
		2756273810	04/05/2016	WW 5806 EE180		11.63
		2756274951	04/06/2016	SW 3796 EE180		15.10
		2756272488	04/04/2016	SENIOR CENTER 5332 EE180		39.19
		2756284714	04/14/2016	PD 4450 EE180		12.13
		2756277589	04/08/2016	WW 1680 EE180		27.46
		2756284873	04/14/2016	PD 4494 EE180		30.71
		2756285250	04/14/2016	PD 4494 EE180		6.33
		2756283757	04/13/2016	PD 3206 EE180		6.33
		2756283942	04/13/2016	PD 5714 EE180		20.15
		2756285884	04/15/2016	PD 7757 EE180		60.58
		2756283839	04/13/2016	FIRE 8313 EE180		63.43
		2756284712	04/14/2016	PD 1948 EE180		157.20
		2756290650	04/19/2016	PD 8695 EE180		6.33
		2756281545	04/11/2016	ADMIN 3779 EE180		32.62
		2756281359	04/11/2016	ADMIN 3937 EE180		29.43

City of San Luis  
**Payment Batch Register**  
 Bank Account: 1BYPAYABLE - 1st BY Accounts Payable  
 Batch Date: 05/18/2016

Type	Date	Number	Source	Payee Name	EFT Bank/Account	Transaction Amount
		2756291047		04/19/2016	WW 4835 EE180	78.24
		2756289721		04/18/2016	SW 0487 EE180	63.04
		2756291076		04/19/2016	PD 4494 EE180	264.38
		2756291854		04/20/2016	PD 4494 EE180	264.75
		2756290727		04/19/2016	SENIOR CENTER 5332 EE180	157.20
		2756276294		04/07/2016	WATER 4344 EE180	104.67
		2756291862		04/20/2016	WW 4835 EE180	65.17
		2756290828		04/19/2016	WW 4835 EE180	304.76
		2756290835		04/19/2016	WW 4835 EE180	4.42
		2756298380		04/26/2016	PD 4494 EE180	163.67
		2756300665		04/28/2016	WW 4835 EE180	61.44
		2756300666		04/28/2016	HWY USER 4840 EE180	14.90
		2756294174		04/22/2016	PD 1072 EE735	2.40
		2756293982		04/22/2016	PD 6226 EE180	2.40
		2756293981		04/22/2016	PD 0566 EE180	3.84
		2756291947		04/20/2016	FIRE 9272 EE180	139.55
		2756297519		04/25/2016	PD 2586 EE180	2.40
		2756276420		04/07/2016	FIRE 7870 EE180	2.40
		2756292264		04/20/2016	WW 3038 EE735	122.88
		2756301939		04/29/2016	HWY USER 4837 EE180	62.73
		2756301850		04/29/2016	PD 4494 EE180	303.08
		2756301707		04/29/2016	PD 4494 EE735	52.31
		2756292265		04/20/2016	CREDIT	(122.88)
		2756273808		04/05/2016	CREDIT	(12.68)
		2756281051		04/11/2016	CREDIT	(6.54)
		2756275353		04/06/2016	CREDIT	(157.20)
		2756284713		04/14/2016	CREDIT	(157.20)
		2756281049		04/11/2016	CREDIT	(23.74)
		2756291863		04/20/2016	CREDIT	(65.17)
		2756291048		04/19/2016	CREDIT	(88.79)
		2756290834		04/19/2016	CREDIT	(2.40)
		2756300713		04/28/2016	CREDIT	(2.40)
		2756301854		04/29/2016	CREDIT	(81.84)
1BYPAYABLE 1st BY Accounts Payable Totals:				Transactions: 2		\$35,779.17

5/18/16  
 Prepared By:  
 Maggie Dominguez  
 Date: Maggie D.

City of San Luis  
**Payment Batch Register**

Bank Account: 1BYPAYABLE - 1st BY Accounts Payable  
Batch Date: 05/18/2016

Schedule B

Type	Date	Number	Source	Payee Name	EFT Bank/Account	Transaction Amount
Checks:		2				\$35,779.17

City of San Luis  
**Payment Batch Register**

Bank Account: 1BYPAYABLE - 1st BY Accounts Payable  
 Batch Date: 05/19/2016

Type	Date	Number	Source	Payee Name	EFT Bank/Account	Transaction Amount
<b>Bank Account: 1BYPAYABLE - 1st BY Accounts Payable</b>						
Check	05/19/2016	75294	Accounts Payable	CALIFORNIA STATE DISBURSEMENT UNIT		164.31
	Invoice		Date	Description		Amount
		2016-00001050	05/18/2016	532 - GARNISHMENT - CHILD SUPPORT		164.31
Check	05/19/2016	75295	Accounts Payable	CAMPA, MIRIAM ZARAI		2.75
	Invoice		Date	Description		Amount
		REIMB STAND	05/18/2016	REIMB STANDARD		2.75
Check	05/19/2016	75296	Accounts Payable	FOP/ALC		296.00
	Invoice		Date	Description		Amount
		2016-00001051	05/18/2016	714 - FOP/ALC		296.00
Check	05/19/2016	75297	Accounts Payable	INTERNAL REVENUE SERVICE		50.00
	Invoice		Date	Description		Amount
		2016-00001052	05/18/2016	533 - GARNISHMENT		50.00
Check	05/19/2016	75298	Accounts Payable	INTERNAL REVENUE SERVICE		1,817.40
	Invoice		Date	Description		Amount
		IRS	05/18/2016	IRS		1,817.40
Check	05/19/2016	75299	Accounts Payable	NATIONWIDE RETIREMENT SOLUTIONS		126.00
	Invoice		Date	Description		Amount
		2016-00001053	05/18/2016	562 - EODGRS - COUNCIL*		126.00
Check	05/19/2016	75300	Accounts Payable	PUBLIC SAFETY PERSONNEL RET SY		38,818.02
	Invoice		Date	Description		Amount
		psprs 051316	05/18/2016	psprs 051316		38,818.02
Check	05/19/2016	75301	Accounts Payable	PUBLIC SAFETY PERSONNEL RET SY		109.35
	Invoice		Date	Description		Amount
		ASRS LEG051316	05/18/2016	ASRS LEGACY 051316		109.35
Check	05/19/2016	75302	Accounts Payable	PUBLIC SAFETY PERSONNEL RET SY		2,098.75
	Invoice		Date	Description		Amount

City of San Luis  
**Payment Batch Register**  
 Bank Account: 1BYPAYABLE - 1st BY Accounts Payable  
 Batch Date: 05/19/2016

Type	Date	Number	Source	Payee Name	EFT Bank/Account	Transaction Amount
		EORP051316		05/18/2016	PSPRS PPE 051316 EORP	2,098.75
Check	05/19/2016	75303	Accounts Payable	PUBLIC SAFETY PERSONNEL RET SY		157.50
		Invoice		Date	Description	Amount
		LEGACY 051316		05/18/2016	LEGACY 051316	157.50
Check	05/19/2016	75304	Accounts Payable	PUBLIC SAFETY PERSONNEL RET SY		2.26
		Invoice		Date	Description	Amount
		psprs eodcrs0513		05/18/2016	PSPRS EODCRS 051316	2.26
Check	05/19/2016	75305	Accounts Payable	PUBLIC SAFETY PERSONNEL RET SY		947.89
		Invoice		Date	Description	Amount
		psprs ppe 051316		05/18/2016	PSPRS PPE 051316	947.89
Check	05/19/2016	75306	Accounts Payable	ROSAS, FERNANDO		6.50
		Invoice		Date	Description	Amount
		REIMBSTAND		05/18/2016	REIMB STANDARD	6.50
Check	05/19/2016	75307	Accounts Payable	SAN LUIS POLICE OFFICERS ASSOC		315.00
		Invoice		Date	Description	Amount
		2016-00001054		05/18/2016	539 - ASK COPS - SLPD	315.00
Check	05/19/2016	75308	Accounts Payable	SUPPORT PAYMENT CLEARINGHOUSE		3,466.17
		Invoice		Date	Description	Amount
		CS PPE 051316		05/18/2016	CS PPE 051316	3,466.17
Check	05/19/2016	75309	Accounts Payable	UNITED WAY OF YUMA COUNTY INC.		33.00
		Invoice		Date	Description	Amount
		2016-00001055		05/18/2016	705 - UNITED WAY	33.00
Check	05/19/2016	75310	Accounts Payable	UNITED YUMA FIRE FIGHTERS-IAFF		578.50
		Invoice		Date	Description	Amount
		2016-00001056		05/18/2016	543 - IAFF - FIRE DEPT	578.50
Check	05/19/2016	75311	Accounts Payable	YBARRA, RUBEN		9.48
		Invoice		Date	Description	Amount
		LEGAL S		05/18/2016	REIMBURSEMENT	9.48

Schedule C

# City of San Luis Payment Batch Register

Bank Account: 1BYPAYABLE - 1st BY Accounts Payable  
Batch Date: 05/19/2016

Type	Date	Number	Source	Payee Name	EFT Bank/Account	Transaction Amount
Check	05/19/2016	75312	Accounts Payable	YBARRA, RUBEN		11.72
	Invoice		Date	Description		Amount
		humana reimn	05/18/2016	humana		11.72
Check	05/19/2016	75313	Accounts Payable	ZIONS FIRST NATIONAL BANK		85.00
	Invoice		Date	Description		Amount
		2016-00001057	05/18/2016	533 - GARNISHMENT		85.00
1BYPAYABLE 1st BY Accounts Payable Totals:				Transactions: 20		\$49,095.60
Checks:		20		\$49,095.60		

Prepared By:  
*Maggie Dominguez*  
 Date: *Maggie D*  
*5/19/16*

*C*

City of San Luis  
**Payment Batch Register**

Bank Account: 1BYPAYABLE - 1st BY Accounts Payable  
 Batch Date: 05/19/2016

Type	Date	Number	Source	Payee Name	EFT Bank/Account	Transaction Amount
<b>Bank Account: 1BYPAYABLE - 1st BY Accounts Payable</b>						
Check	05/19/2016	75314	Accounts Payable	4 IMPRINT		498.54
	Invoice		Date	Description		Amount
		4574089	04/12/2016	PROMOTIONAL ITEMS FOR THE BUSINESS INCUBATOR		498.54
Check	05/19/2016	75315	Accounts Payable	APPLIED PRODUCTS GROUP LLC		908.53
	Invoice		Date	Description		Amount
		DVJFI4014	04/18/2016	EMERGENCY PURCHASE: MOTOR F/ CHLORINATOR UNIT@WS#7		908.53
Check	05/19/2016	75316	Accounts Payable	BORDER GYM FITNESS LLC		925.00
	Invoice		Date	Description		Amount
		0004	05/03/2016	MONTHLY SERVICE FEE - APRIL 2016		925.00
Check	05/19/2016	75317	Accounts Payable	CARBAJAL , EDGAR		233.39
	Invoice		Date	Description		Amount
		CARBAJAL 051816	05/18/2016	REIMBURSEMENT - HERTZ CAR RENTAL IN ORLANDO FLORIDA		233.39
Check	05/19/2016	75318	Accounts Payable	CASTILLO , DANIA		221.00
	Invoice		Date	Description		Amount
		CASTILLO 052216	05/18/2016	TRAVEL - 2016 RECON CONVENTION		221.00
Check	05/19/2016	75319	Accounts Payable	CITY OF YUMA		36,261.57
	Invoice		Date	Description		Amount
		2016-000000044	01/05/2016	PUBLIC SAFETY SOFTWARE SYS MAIN AND YRCS RADIO FEES		7,461.73
		2016-00001067	05/18/2016	PUBLIC SAFETY SOFTWARE/SYSTEMS - RADIO FEES		28,799.84
Check	05/19/2016	75320	Accounts Payable	EDUCATIONAL SERVICES INC		7,242.72
	Invoice		Date	Description		Amount
		005589	05/06/2016	EMPLOYEE COST AGREEMENT FOR J. DELAVARA - PPE 042316		7,242.72
Check	05/19/2016	75321	Accounts Payable	ENGINEERED WITH LAYTON		19,605.62
	Invoice		Date	Description		Amount
		1168	01/11/2016	WS#7 MANGANESE REMOVAL TREATMENT PROJECT-INV#1168 & 1150		3,222.00
		1150	12/14/2015	WS#7 MANGANESE REMOVAL TREATMENT PROJECT-INV#1168 & 1150		16,383.62
Check	05/19/2016	75322	Accounts Payable	FERNANDEZ , JENNY		193.00

City of San Luis  
**Payment Batch Register**  
 Bank Account: 1BYPAYABLE - 1st BY Accounts Payable  
 Batch Date: 05/19/2016

Type	Date	Number	Source	Payee Name	EFT Bank/Account	Transaction Amount
	Invoice			Date	Description	Amount
		FERNANDEZ 050416		05/12/2016	TRAVEL - LIFEGUARD CERTIFICATION COURSES	193.00
Check	05/19/2016	75323	Accounts Payable	FX LAB LLC		542.05
	Invoice			Date	Description	Amount
		211		05/05/2016	POLICE WEEK TRAVEL MUGS	542.05
Check	05/19/2016	75324	Accounts Payable	GIMBUT, GLENN J.		91.00
	Invoice			Date	Description	Amount
		GIMBUT 052416		05/18/2016	TRAVEL - DEPOSITION RE: SLFDC VS CEC	91.00
Check	05/19/2016	75325	Accounts Payable	GUERRA , RUTH		1,000.00
	Invoice			Date	Description	Amount
		131		05/13/2016	TRANSLATING SERVICES FOR COURT - 050916-051316	500.00
		130		05/02/2016	TRANSLATING SERVICES FOR COURT - 050216-050616	500.00
Check	05/19/2016	75326	Accounts Payable	GUERRERO , JUAN MANUEL		1,336.00
	Invoice			Date	Description	Amount
		2016-00001062		05/18/2016	TEMPORARY MAGISTRATE FOR MUNICIPAL COURT 050216-051216	1,336.00
Check	05/19/2016	75327	Accounts Payable	GUZMAN , FRANCISCA		50.00
	Invoice			Date	Description	Amount
		6/2016		04/27/2016	TRANSLATING SERVICES FOR COUNCIL MEETING - 042716	50.00
Check	05/19/2016	75328	Accounts Payable	ID WHOLESALER		357.00
	Invoice			Date	Description	Amount
		1212870		03/24/2016	PROXY CARDS	357.00
Check	05/19/2016	75329	Accounts Payable	KALLEN , CID RIGEL		1,600.00
	Invoice			Date	Description	Amount
		2259		04/27/2016	ATTORNEY FEES	400.00
		2258		04/27/2016	ATTORNEY FEES	400.00
		2261		04/27/2016	ATTORNEY FEES	400.00
		2263		04/27/2016	ATTORNEY FEES	400.00
Check	05/19/2016	75330	Accounts Payable	KANAWHA INSURANCE CO.		539.00
	Invoice			Date	Description	Amount

City of San Luis  
**Payment Batch Register**

Bank Account: 1BYPAYABLE - 1st BY Accounts Payable  
 Batch Date: 05/19/2016

Type	Date	Number	Source	Payee Name	EFT Bank/Account	Transaction Amount
		2016-00001040		05/18/2016	INSURANCE FOR APRIL 2016	539.00
Check	05/19/2016	75331	Accounts Payable	LIBERTY MOTORSPORTS		949.35
		Invoice		Date	Description	Amount
		96617126		04/26/2016	INSTALLATION OF BRAKE PADS ON POLICE DEPT VIN# 0051	117.82
		96617733		05/12/2016	PURCHASE OF AUTOMOTIVE PARTS FOR POLICE DEPT VIN# 0066	831.53
Check	05/19/2016	75332	Accounts Payable	LOPEZ RIOS , JOSE A		126.00
		Invoice		Date	Description	Amount
		2016-00001063		05/18/2016	SERVICES RENDERED OF UMPIRE FOR WOMEN'S VOLLEYBALL LEAGUE 2016	126.00
Check	05/19/2016	75333	Accounts Payable	LUNA, JESUS ENRIQUE		37.31
		Invoice		Date	Description	Amount
		LUNA 051816		05/18/2016	REIMBURSEMENT - BREAD FOR MOTHERS DAY CELEBRATION AT SENIOR CTR	37.31
Check	05/19/2016	75334	Accounts Payable	MADRIGAL, JOSE LUIS		100.00
		Invoice		Date	Description	Amount
		MADRIGAL 051816		05/18/2016	REIMBURSEMENT - STEEL TOE BOOTS	100.00
Check	05/19/2016	75335	Accounts Payable	MASSMUTUAL FINANCIAL GROUP		120.00
		Invoice		Date	Description	Amount
		2016-00001038		05/18/2016	INSURANCE FOR MARCH 2016	60.00
		2016-00001039		05/18/2016	INSURANCE FOR APRIL 2016	60.00
Check	05/19/2016	75336	Accounts Payable	MISS SAN LUIS SCHOLARSHIP PAGEANT ASSOC.		5,000.00
		Invoice		Date	Description	Amount
		2016-00001061		05/18/2016	SPONSORSHIPS: 5TH ANNUAL OFF ROAD EXPO	5,000.00
Check	05/19/2016	75337	Accounts Payable	NEW YORK LIFE INSURANCE CO.		507.36
		Invoice		Date	Description	Amount
		2016-00001041		05/18/2016	INSURANCE FOR MARCH 2016	169.12
		2016-00001042		05/18/2016	INSURANCE FOR APRIL 2016	169.12
		2016-00001043		05/18/2016	INSURANCE FOR MAY 2016	169.12
Check	05/19/2016	75338	Accounts Payable	PEREZ , JORGE		100.00
		Invoice		Date	Description	Amount



City of San Luis  
**Payment Batch Register**  
 Bank Account: 1BYPAYABLE - 1st BY Accounts Payable  
 Batch Date: 05/19/2016

Type	Date	Number	Source	Payee Name	EFT Bank/Account	Transaction Amount
Check	05/19/2016	75345	Accounts Payable	ST. LOUIS, KETIE		349.00
	Invoice		Date	Description		Amount
		ST. LOUIS 052116	05/18/2016	TRAVEL - FULFILL CPE REQUIREMENTS FOR CPA LICENSE		349.00
Check	05/19/2016	75346	Accounts Payable	STANDARD INSURANCE CO.		1,352.20
	Invoice		Date	Description		Amount
		2016-00001035	05/18/2016	INSURANCE FOR APRIL 2016		1,352.20
Check	05/19/2016	75347	Accounts Payable	THOMSON WEST PUBLISHING CO.		776.35
	Invoice		Date	Description		Amount
		833742980	04/01/2016	INTERNET SERVICES FOR MARCH 2016		776.35
Check	05/19/2016	75348	Accounts Payable	TORRES, JENNY		221.00
	Invoice		Date	Description		Amount
		TORRES 052216	05/18/2016	TRAVEL - 2016 RECON CONVENTION		221.00
Check	05/19/2016	75349	Accounts Payable	TOSHIBA FINANCIAL SERVICES		1,270.36
	Invoice		Date	Description		Amount
		2016-00001049	05/18/2016	CONTRACT #: 0288609, 0289723, 0373070, 0398771		1,270.36
Check	05/19/2016	75350	Accounts Payable	TRANSWESTERN INSURANCE ADMIN		299.40
	Invoice		Date	Description		Amount
		2016-00001034	05/18/2016	INSURANCE FOR MAY 2016		299.40
Check	05/19/2016	75351	Accounts Payable	US BANK EQUIPMENT FINANCE		2,323.38
	Invoice		Date	Description		Amount
		2016-00001047	05/18/2016	CONTRACT: 500-0380583, 500-0408239, 500-0413948, 500-0448410		2,323.38
Check	05/19/2016	75352	Accounts Payable	VELEZ , RALPH G		1,403.20
	Invoice		Date	Description		Amount
		2016-00001064	05/18/2016	CONSULTING SERVICES FOR 050316, 050416		591.10
		2016-00001065	05/18/2016	CONSULTING SERVICES FOR 051716, 051816		591.10
		VELEZ 052216	05/18/2016	TRAVEL - 2016 RECON CONVENTION		221.00
Check	05/19/2016	75353	Accounts Payable	VISION SERVICE PLAN OF ARIZONA		3,502.75
	Invoice		Date	Description		Amount

City of San Luis  
**Payment Batch Register**

Schedule D

Bank Account: 1BYPAYABLE - 1st BY Accounts Payable  
 Batch Date: 05/19/2016

Type	Date	Number	Source	Payee Name	EFT Bank/Account	Transaction Amount
		2016-00001044		05/18/2016	INSURANCE FOR MAY 2016	3,502.75
Check	05/19/2016	75354	Accounts Payable	YUMA AUTO REBUILDERS		3,657.70
		Invoice		Date	Description	Amount
		3781767		04/26/2016	FRONT BODY REPAIR FOR FLEET SERVICES DEPT VIN# 1172	1,900.00
		3714394		04/26/2016	REPAIR BED SIDE PANELS FOR POLICE DEPT VIN# 4851	1,757.70
Check	05/19/2016	75355	Accounts Payable	YUMA COUNTY ADULT DETENTION CENTER		358.37
		Invoice		Date	Description	Amount
		2016-00001059		05/18/2016	INCARCERATION FEE COLLECTED FOR APRIL 2016/SAN LUIS MUNI COURT	358.37
Check	05/19/2016	75356	Accounts Payable	YUMA COUNTY HUMANE SOCIETY		6,643.00
		Invoice		Date	Description	Amount
		2016-00001066		05/09/2016	KENNELING SERVICES FOR APRIL 2016	6,643.00
Check	05/19/2016	75357	Accounts Payable	YUMA COUNTY TREASURER		240.39
		Invoice		Date	Description	Amount
		2016-00001060		05/18/2016	FUNDS COLLECTED FOR APRIL 2016/SAN LUIS MUNI COURT	240.39
Check	05/19/2016	75358	Accounts Payable	YUMA OFFICE EQUIPMENT		2,506.94
		Invoice		Date	Description	Amount
		2016-00001058		05/18/2016	CNTRCT: 768, 769, 1188, 1046, 1162, 1104, 1103, 1209, 1347	2,506.94
Check	05/19/2016	75359	Accounts Payable	YUMA SUN, INC		2,009.12
		Invoice		Date	Description	Amount
		92082		05/04/2016	LEGAL PUBLICATIONS	71.18
		00089132		04/10/2016	MAGISTRATE AD	399.00
		00089793		04/17/2016	PARKS AND REC DIRECTOR AD	399.00
		00087777		04/01/2016	AD OF 2016 NEIGHBORHOOD CLEAN-UP CAMPAIGN MAP IN BAJO EL SOL	599.00
		00086928		04/03/2016	CDBG #107-16, LAKIN DR. BID ADVERTISEMENT	313.18
		000089265		04/24/2016	CITY TAX CODE LEGAL PUBLICATION	227.76

1BYPAYABLE 1st BY Accounts Payable Totals: Transactions: 46  
 Checks: 46 \$166,505.40

Prepared By:  
 Maggie Dominguez  
 Date: Maggie D.  
5/19/16  
 5/19/2016 2:55:33 PM

City of San Luis  
**Payment Batch Register**

Schedule E

Bank Account: 1BYPAYABLE - 1st BY Accounts Payable  
 Batch Date: 05/19/2016

Type	Date	Number	Source	Payee Name	EFT Bank/Account	Transaction Amount
<b>Bank Account: 1BYPAYABLE - 1st BY Accounts Payable</b>						
Check	05/19/2016	75360	Accounts Payable	ARIZONA STATE TREASURER		45,023.89
	Invoice		Date	Description		Amount
		2016-00001069	05/19/2016	FUNDS COLLECTED FOR APRIL 2016/SAN LUIS MUNI COURT		45,023.89
Check	05/19/2016	75361	Accounts Payable	CESAR CHAVEZ ELEMENTARY SCHOOL		500.00
	Invoice		Date	Description		Amount
		2016-00001068	05/19/2016	CCS PTO-DANCE TEAM		500.00
1BYPAYABLE 1st BY Accounts Payable Totals:				Transactions: 2		\$45,523.89
Checks:		2		\$45,523.89		

Prepared By:  
 Maggie Dominguez  
 Date: Maggie D.  
 C 5/19/16



Schedule F

# Pay Day Register Report

Pay Date Range 04/30/16 - 05/13/16

Pay Batch 201610

UNITED WAY	33.00
US & MEX DENTAL= FAMILY	619.50
US & MEX HEALTH = C	5,757.17
US & MEX HEALTH = FAMILY	3,009.44
US & MEX HEALTH = SP	1,404.10
VSP - VISION FAMILY	596.70
Net	<u>\$241,961.99</u> ✓

.00	National Bank	650.00
.00	Navy Federal	2,901.05
.00	NetSpend Corporation DD	120.00
.00	NORTH ISLAND CREDIT UNION	773.31
.00	Sunbank	466.86
.00	THE FOOTHILLS BANK	1,870.20
.00	WASHINGTON FEDERAL	4,324.41
	Wells Fargo	<u>47,394.47</u>
	Total	<u>\$220,839.62</u>
	Check	\$21,122.37



Schedule G

# Pay Day Register Report

Pay Date Range 05/01/16 - 05/31/16

Pay Batch 201605M

Pay Batch 201605M Total

Employees in Pay Batch 7

Female Employees in Pay Batch 3

Hours Description

Hours Description	Hours	Gross	Withholdings and Deductions	Gross Base	Benefits	Amount
102 - SALARY	.0000	7,550.00	Gross	7,750.00	ASRS Council	102.15
806 - TELEPHONE STIPEND	.0000	200.00	FEDERAL TAX WITHHOLDING	30.80	ASRS LTD Council	1.08
Total	0.0000	\$7,750.00	SOCIAL SECURITY TAX	480.50	EODCRS - COUNCIL	54.00
			MEDICARE	112.35	EODCRS - DISABILITY	1.13
			STATE WITHHOLDING	135.59	EORP - LEGACY RATE COUNCIL	157.50
			ASRS Council	102.15	EORP COUNCIL RETIREMENT	1,351.25
			ASRS LTD Council	1.08	U.S. MEX DENTAL COUNCIL - CHILD	51.04
			EODCRS - COUNCIL	72.00	U.S. MEX DENTAL COUNCIL - FAM	63.70
			EODCRS - DISABILITY	1.13	US & MEX DENTAL COUNCIL = EE	97.83
			EORP COUNCIL RETIREMENT	747.50	US & MEX HLTH COUNCIL = C	1,686.26
			MISCELLANEOUS	50.00	US & MEX HLTH COUNCIL = EE ONLY	1,625.19
			U.S. MEX DENTAL COUNCIL -	79.40	US & MEX HLTH COUNCIL = F	2,579.54
			U.S. MEX DENTAL COUNCIL -	99.12	VISION - COUNCIL SINGLE	40.72
			US & MEX HEALTH COUNCIL =	562.10	VSP VISION- COUNCIL	30.54
			US & MEX HEALTH COUNCIL = F	859.84	Total	\$7,841.93
			VSP - VISION COUNCIL	35.10		
			Net	\$4,381.34	Direct Deposits	Amount
					1st Bank Yuma	714.54
					Chase Bank	738.42
					Federal Credit Union	860.32
					REALTORS FED CRED UNION	551.37
					Sunbank	413.45
					Wells Fargo	381.70
					Total	\$3,659.80
					Check	\$721.54

Schedule H

City of San Luis  
**Payment Batch Register**  
Bank Account: 1BYPAYABLE - 1st BY Accounts Payable  
Batch Date: 05/24/2016

Type	Date	Number	Source	Payee Name	EFT Bank/Account	Transaction Amount
<b>Bank Account: 1BYPAYABLE - 1st BY Accounts Payable</b>						
Check	05/24/2016	75362	Accounts Payable	DE LA HOYA, TADEO		495.00
	Invoice		Date	Description		Amount
		DELAHOYA 052416	05/24/2016	PAYROLL		495.00
1BYPAYABLE 1st BY Accounts Payable Totals:				Transactions: 1		\$495.00
Checks:		1		\$495.00		

Prepared By:  
*Maggie Dominguez*  
 Date: *Maggie D.*  
*C* 5/24/16

City of San Luis  
**Payment Batch Register**  
 Bank Account: 1BYPAYABLE - 1st BY Accounts Payable  
 Batch Date: 05/24/2016

Type	Date	Number Source	Payee Name	EFT Bank/Account	Transaction Amount
<b>Bank Account: 1BYPAYABLE - 1st BY Accounts Payable</b>					
Check	05/24/2016	75363 Utility Management Refund	ANDRADE , VALENTIN		220.93
	Account Type		Account Number	Transaction Date	Transaction Type
Check	05/24/2016	75364 Utility Management Refund	BELTRAN , MARIBEL		149.81
	Account Type		Account Number	Transaction Date	Transaction Type
Check	05/24/2016	75365 Utility Management Refund	CEBREROS , ALEJANDRA		137.06
	Account Type		Account Number	Transaction Date	Transaction Type
Check	05/24/2016	75366 Utility Management Refund	ESTRADA-GONZALEZ, MAURICIO - GRP 64		2.43
	Account Type		Account Number	Transaction Date	Transaction Type
Check	05/24/2016	75367 Utility Management Refund	GARCIA , JORGE L		69.62
	Account Type		Account Number	Transaction Date	Transaction Type
Check	05/24/2016	75368 Utility Management Refund	HERNANDEZ , DANIELLE		128.30
	Account Type		Account Number	Transaction Date	Transaction Type
Check	05/24/2016	75369 Utility Management Refund	HERNANDEZ , JUAN M & JUANA		142.60
	Account Type		Account Number	Transaction Date	Transaction Type
Check	05/24/2016	75370 Utility Management Refund	MADERO, ARMANDO & GUADALUPE GARIBAY		135.61
	Account Type		Account Number	Transaction Date	Transaction Type
Check	05/24/2016	75371 Utility Management Refund	MEJIA , ANA LILIA		133.93
	Account Type		Account Number	Transaction Date	Transaction Type
Check	05/24/2016	75372 Utility Management Refund	MORENO-RUIZ, PEDRO - GRP 64		16.93
	Account Type		Account Number	Transaction Date	Transaction Type
Check	05/24/2016	75373 Utility Management Refund	RIEDEL CONSTRUCTION		15.20
	Account Type		Account Number	Transaction Date	Transaction Type
	Residential		233211-001	05/17/2016	Refund - Account Credit
Check	05/24/2016	75374 Utility Management Refund	ROBLES, JUAN J & SELENE - GRP 64		13.98

City of San Luis  
**Payment Batch Register**  
 Bank Account: 1BYPAYABLE - 1st BY Accounts Payable  
 Batch Date: 05/24/2016

Schedule I

Type	Date	Number Source	Payee Name	EFT Bank/Account	Transaction Amount
		<u>Account Type</u>	<u>Account Number</u>	<u>Transaction Date</u>	<u>Transaction Type</u>
Check	05/24/2016	75375 Utility Management Refund	SANCHEZ, GABRIELA & JOSE CASTRO		143.62
		<u>Account Type</u>	<u>Account Number</u>	<u>Transaction Date</u>	<u>Transaction Type</u>
Check	05/24/2016	75376 Utility Management Refund	SUAREZ , MARIA JESUSA		121.98
		<u>Account Type</u>	<u>Account Number</u>	<u>Transaction Date</u>	<u>Transaction Type</u>
Check	05/24/2016	75377 Utility Management Refund	TORRES , JESUS		19.16
		<u>Account Type</u>	<u>Account Number</u>	<u>Transaction Date</u>	<u>Transaction Type</u>
Check	05/24/2016	75378 Utility Management Refund	VILLAPUDUA , PASCUALA		58.19
		<u>Account Type</u>	<u>Account Number</u>	<u>Transaction Date</u>	<u>Transaction Type</u>

1BYPAYABLE 1st BY Accounts Payable Totals: Transactions: 16 \$1,509.35

Checks: 16 \$1,509.35

Prepared By:  
 Maggie Dominguez  
 Date: Maggie D.  
 C 5/24/16

City of San Luis  
**Payment Batch Register**  
 Bank Account: 1BYPAYABLE - 1st BY Accounts Payable  
 Batch Date: 05/26/2016

Type	Date	Number	Source	Payee Name	EFT Bank/Account	Transaction Amount
<b>Bank Account: 1BYPAYABLE - 1st BY Accounts Payable</b>						
Check	05/26/2016	75379	Accounts Payable	AL-SAIHATI, TERRILL		700.00
	Invoice		Date	Description		Amount
		00007	05/13/2016	PETTING ZOO SERVICES FOR GESD SPECIAL OLYMPICS		700.00
Check	05/26/2016	75380	Accounts Payable	ALBERT HOLLER & ASSOCIATES		2,000.00
	Invoice		Date	Description		Amount
		MAY 2016	05/25/2016	SALES TAX AUDITOR FOR MAY 2016		2,000.00
Check	05/26/2016	75381	Accounts Payable	ALSCO, INC		2,627.74
	Invoice		Date	Description		Amount
		LYUM1054618	04/01/2016	UNIFORM SERVICE FOR PW PERSONNEL - APRIL 2016		102.63
		LYUM1056645	04/08/2016	UNIFORM SERVICE FOR PW PERSONNEL - APRIL 2016		93.56
		LYUM1056072	04/08/2016	UNIFORM SERVICE FOR PW PERSONNEL - APRIL 2016		19.93
		LYUM1058577	04/15/2016	UNIFORM SERVICE FOR PW PERSONNEL - APRIL 2016		93.56
		LYUM1060546	04/22/2016	UNIFORM SERVICE FOR PW PERSONNEL - APRIL 2016		93.56
		LYUM1062475	04/29/2016	UNIFORM SERVICE FOR PW PERSONNEL - APRIL 2016		91.63
		LYUM1054612	04/01/2016	UNIFORM SERVICE FOR PW PERSONNEL - APRIL 2016		113.08
		LYUM1056639	04/08/2016	UNIFORM SERVICE FOR PW PERSONNEL - APRIL 2016		113.08
		LYUM1058571	04/15/2016	UNIFORM SERVICE FOR PW PERSONNEL - APRIL 2016		113.08
		LYUM1060540	04/22/2016	UNIFORM SERVICE FOR PW PERSONNEL - APRIL 2016		113.08
		LYUM1062469	04/29/2016	UNIFORM SERVICE FOR PW PERSONNEL - APRIL 2016		110.74
		LYUM1054613	04/01/2016	UNIFORM SERVICE FOR PW PERSONNEL - APRIL 2016		123.59
		LYUM1056640	04/08/2016	UNIFORM SERVICE FOR PW PERSONNEL - APRIL 2016		123.59
		LYUM1058572	04/15/2016	UNIFORM SERVICE FOR PW PERSONNEL - APRIL 2016		123.59
		LYUM1060541	04/22/2016	UNIFORM SERVICE FOR PW PERSONNEL - APRIL 2016		123.59
		LYUM1062470	04/29/2016	UNIFORM SERVICE FOR PW PERSONNEL - APRIL 2016		121.03
		LYUM1054611	04/01/2016	UNIFORM SERVICE FOR PW PERSONNEL - APRIL 2016		36.36
		LYUM1056638	04/08/2016	UNIFORM SERVICE FOR PW PERSONNEL - APRIL 2016		36.36
		LYUM1058570	04/15/2016	UNIFORM SERVICE FOR PW PERSONNEL - APRIL 2016		36.36
		LYUM1060539	04/22/2016	UNIFORM SERVICE FOR PW PERSONNEL - APRIL 2016		36.36
		LYUM1062468	04/29/2016	UNIFORM SERVICE FOR PW PERSONNEL - APRIL 2016		35.61
		LYUM1060544	04/22/2016	UNIFORM SERVICES - FACILITIES		61.36
		LYUM1058575	04/15/2016	UNIFORM SERVICES - FACILITIES		61.36

City of San Luis  
**Payment Batch Register**  
 Bank Account: 1BYPAYABLE - 1st BY Accounts Payable  
 Batch Date: 05/26/2016

Type	Date	Number	Source	Payee Name	EFT Bank/Account	Transaction Amount
		LYUM1062473	04/29/2016	UNIFORM SERVICES - FACILITIES		58.30
		LYUM1054617	04/01/2016	UNIFORM SERVICES - PARKS AND REC		86.32
		LYUM1056644	04/08/2016	UNIFORM SERVICES - PARKS AND REC		86.32
		LYUM1058576	04/15/2016	UNIFORM SERVICES - PARKS AND REC		83.28
		LYUM1060545	04/22/2016	UNIFORM SERVICES - PARKS AND REC		83.28
		LYUM1062472	04/29/2016	UNIFORM SERVICES - FLEET SERVICES		49.79
		LYUM1058574	04/15/2016	UNIFORM SERVICES - FLEET SERVICES		50.84
		LYUM1060543	04/22/2016	UNIFORM SERVICES - FLEET SERVICES		50.84
		LYUM1050734	03/18/2016	UNIFORM SERVICES - FLEET SERVICES		50.84
		LYUM1052693	03/25/2016	UNIFORM SERVICES - FLEET SERVICES		50.84
Check	05/26/2016	75382	Accounts Payable	ANGEL'S TOWING SERVICE/AUTO SALES		685.00
		Invoice	Date	Description		Amount
		1951	05/13/2016	TOW SERVICE FOR SLPD IMPOUNDED VEHICLES		75.00
		1763	05/10/2016	TOW SERVICE FOR SLPD IMPOUNDED VEHICLES		75.00
		1764	05/11/2016	TOW SERVICE FOR SLPD IMPOUNDED VEHICLES		75.00
		1765	05/12/2016	TOW SERVICE FOR SLPD IMPOUNDED VEHICLES		85.00
		1758	04/04/2016	TOW SERVICE FOR SLPD IMPOUNDED VEHICLES		75.00
		1759	05/06/2016	TOW SERVICE FOR SLPD IMPOUNDED VEHICLES		75.00
		1760	05/07/2016	TOW SERVICE FOR SLPD IMPOUNDED VEHICLES		75.00
		1761	05/09/2016	TOW SERVICE FOR SLPD IMPOUNDED VEHICLES		75.00
		1762	05/09/2016	TOW SERVICE FOR SLPD IMPOUNDED VEHICLES		75.00
Check	05/26/2016	75383	Accounts Payable	APPLIED PRODUCTS GROUP LLC		9,948.67
		Invoice	Date	Description		Amount
		DVJFI4008-02	05/16/2016	CHLORINE USED FOR WATER TREATMENT SKIDS & MTU's - 2/3		9,948.67
Check	05/26/2016	75384	Accounts Payable	ARCTIC GLACIER USA INC		136.00
		Invoice	Date	Description		Amount
		2673612005	04/29/2016	10 LB ICE CUBE BAGS FOR FIRE DEPARTMENT		136.00
Check	05/26/2016	75385	Accounts Payable	ARIZONA BRAKE & CLUTCH SUPPLY		1,090.06
		Invoice	Date	Description		Amount
		37903	05/03/2016	PURCHASE OF AUTOMOTIVE PART FOR HWY USER DEPT VIN# 3580		244.41
		37938	05/05/2016	VW 8771/2467 EE180		227.06

City of San Luis  
**Payment Batch Register**

Bank Account: 1BYPAYABLE - 1st BY Accounts Payable  
 Batch Date: 05/26/2016

Type	Date	Number	Source	Payee Name	EFT Bank/Account	Transaction Amount
		38136		05/12/2016	HWY USER 1342 EE735	387.46
		38190		05/13/2016	HWY USER 1342 EE180	52.41
		38257		05/18/2016	PURCHASE OF TOOLS FOR CITY SHOP	178.72
Check	05/26/2016	75386	Accounts Payable	ARIZONA PUBLIC SERVICE		476.11
		Invoice		Date	Description	Amount
		AR0170000959		04/08/2016	BORDER BUSINESS CASE BOOKLETS	476.11
Check	05/26/2016	75387	Accounts Payable	ARIZONA REFUSE SALES, LLC		758.29
		Invoice		Date	Description	Amount
		00030555		04/29/2016	PURCHASE OF AUTOMOTIVE PARTS FOR SOLID WASTE DEPT VIN# 3796	758.29
Check	05/26/2016	75388	Accounts Payable	BILL ALEXANDER FORD		48.25
		Invoice		Date	Description	Amount
		322351		05/06/2016	HWY USER 2934 EE735	48.25
Check	05/26/2016	75389	Accounts Payable	BLT READY MIX CONCRETE LLC		466.37
		Invoice		Date	Description	Amount
		660390		04/29/2016	MATERIAL (CONCRETE) USED TO REPAIR SIDEWALKS CITYWIDE	466.37
Check	05/26/2016	75390	Accounts Payable	CAMARENA, CORNELIUS		1,200.00
		Invoice		Date	Description	Amount
		4753		11/20/2015	ATTORNEY FEES	400.00
		4651		01/14/2016	ATTORNEY FEES	400.00
		4650		02/22/2016	ATTORNEY FEES	400.00
Check	05/26/2016	75391	Accounts Payable	CANYON TELECOM INC		106.28
		Invoice		Date	Description	Amount
		TH042816A		04/28/2016	VIRTUAL PHONE FOR COUNCIL CHAMBER	106.28
Check	05/26/2016	75392	Accounts Payable	CDWG		8,107.19
		Invoice		Date	Description	Amount
		CTN8639		04/21/2016	WIRELESS KEYBOARD AND MOUSE FOR CONFERENCE ROOM 151	56.42
		CXZ9496		05/06/2016	PSU REPLACEMENT FOR FINANCE	37.06
		CXB3576		05/03/2016	PURCHASE OF TONERS FOR PRINTER (YOLANDA DUENAS)	361.93
		CXB8749		05/03/2016	CARTRIDGES/INK FOR MR. HIGGINS	238.28

City of San Luis  
**Payment Batch Register**  
 Bank Account: 1BYPAYABLE - 1st BY Accounts Payable  
 Batch Date: 05/26/2016

Type	Date	Number	Source	Payee Name	EFT Bank/Account	Transaction Amount
		CWN1037		04/29/2016	DOMAIN CONTROLLER SERVER LICENCES	7,413.50
Check	05/26/2016	75393	Accounts Payable	CITY OF YUMA		75.17
		Invoice		Date	Description	Amount
		2016-0000001		03/29/2016	AHA PROVIDER CARDS - BLS	75.17
Check	05/26/2016	75394	Accounts Payable	CRUZ-SOTO , ARTURO		1,623.00
		Invoice		Date	Description	Amount
		2016-00001082		05/25/2016	REIMBURSEMENT CASE 2016-5808 ITEM 5	1,623.00
Check	05/26/2016	75395	Accounts Payable	CSC OF YUMA		113.69
		Invoice		Date	Description	Amount
		000516740		05/06/2016	SOLID WASTE 9938 EE735	39.44
		000514480		04/21/2016	SOLID WASTE 0487 EE735	74.25
Check	05/26/2016	75396	Accounts Payable	CUEN , BERNARDO		110.00
		Invoice		Date	Description	Amount
		2016-00001080		05/25/2016	SERVICES RENDERED OF SCOREKEEPER FOR GIRLS SOFTBALL LEAGUE 2016	110.00
Check	05/26/2016	75397	Accounts Payable	DAMAGE RECOVERY UNIT		60.00
		Invoice		Date	Description	Amount
		TR.2015.00433		05/24/2016	RESTITUTION	60.00
Check	05/26/2016	75398	Accounts Payable	DANA-KEPNER COMPANY INC.		18,738.17
		Invoice		Date	Description	Amount
		8141618-00		05/16/2016	METERS/MATERIALS FOR NEW INSTALLATIONS/REPAIRS/REPLACEMENTS	18,023.00
		8140335-01		03/15/2016	MATERIAL F/ NEW INSTALLATIONS AND/OR REPAIRS F/ WTR DIST. SYSTEM	409.89
		8140335-00		03/07/2016	MATERIAL F/ NEW INSTALLATIONS AND/OR REPAIRS F/ WTR DIST. SYSTEM	305.28
Check	05/26/2016	75399	Accounts Payable	DESERT WATER		913.01
		Invoice		Date	Description	Amount
		1244154		04/13/2016	12.6 GALS OF PROPANE GAS FOR FIRE DEPT	33.61
		62239		03/01/2016	WATER FOR PW PERSONNEL - MARCH 2016	55.38
		62319		03/08/2016	WATER FOR PW PERSONNEL - MARCH 2016	66.45
		62387		03/15/2016	WATER FOR PW PERSONNEL - MARCH 2016	66.45
		62439		03/23/2016	WATER FOR PW PERSONNEL - MARCH 2016	66.45

City of San Luis  
**Payment Batch Register**  
 Bank Account: 1BYPAYABLE - 1st BY Accounts Payable  
 Batch Date: 05/26/2016

Type	Date	Number	Source	Payee Name	EFT Bank/Account	Transaction Amount
		63019		03/29/2016	WATER FOR PW PERSONNEL - MARCH 2016	55.37
		62471		04/05/2016	WATER SERVICE FOR PW PERSONNEL - APRIL 2016	66.45
		62543		04/12/2016	WATER SERVICE FOR PW PERSONNEL - APRIL 2016	66.45
		62591		04/18/2016	WATER SERVICE FOR PW PERSONNEL - APRIL 2016	66.45
		62687		04/26/2016	WATER SERVICE FOR PW PERSONNEL - APRIL 2016	66.45
		62438		03/23/2016	BULK DRINKING WATER FOR VARIOUS DEPTS	44.30
		63020		03/29/2016	BULK DRINKING WATER FOR VARIOUS DEPTS	42.08
		62467		04/05/2016	BULK DRINKING WATER FOR VARIOUS DEPTS	44.30
		62542		04/12/2016	BULK DRINKING WATER FOR VARIOUS DEPTS	44.30
		62592		04/18/2016	BULK DRINKING WATER FOR VARIOUS DEPTS	33.25
		62689		04/26/2016	BULK DRINKING WATER FOR VARIOUS DEPTS	62.02
		62759		05/03/2016	BULK DRINKING WATER FOR VARIOUS DEPTS	33.25
Check	05/26/2016	75400	Accounts Payable	DIRECTV, INC		116.98
		Invoice	Date	Description		Amount
		28540260012	05/25/2016	DIRECTV MONTHLY SERVICES FOR YOUTH CENTER - 0515-0614		116.98
Check	05/26/2016	75401	Accounts Payable	EDUCATIONAL SERVICES INC		7,242.73
		Invoice	Date	Description		Amount
		005687	05/20/2016	EMPLOYEE COST AGREEMENT FOR J. DELAVARA PPE 050716		7,242.73
Check	05/26/2016	75402	Accounts Payable	EXCEPTIONAL WATER SYSTEMS, LLC		575.69
		Invoice	Date	Description		Amount
		4818	04/28/2016	PURCHASE OF CHEMICAL TABLETS FOR THE AQUATIC CENTER POOL		575.69
Check	05/26/2016	75403	Accounts Payable	FISHER CHEVROLET - PARTS		377.12
		Invoice	Date	Description		Amount
		408574	05/04/2016	PURCHASE OF AUTOMOTIVE PARTS FOR WATER DEPT VIN# 4174		377.12
Check	05/26/2016	75404	Accounts Payable	FNP-C & ASSOCIATES PLLC		80.00
		Invoice	Date	Description		Amount
		103	05/04/2016	EDUARDO ZATARAIN GDL/DOT EXAM		80.00
Check	05/26/2016	75405	Accounts Payable	GARCIA, JESUS		500.00
		Invoice	Date	Description		Amount
		137377	05/04/2016	SERVICES RENDERED FOR DISTRIBUTION OF HOT DOGS: SPECIAL OLYMPICS		500.00

City of San Luis  
**Payment Batch Register**  
 Bank Account: 1BYPAYABLE - 1st BY Accounts Payable  
 Batch Date: 05/26/2016

Type	Date	Number	Source	Payee Name	EFT Bank/Account	Transaction Amount
Check	05/26/2016	75406	Accounts Payable	GERARDO FELIX /SAN LUIS FIRE EXTINGUISHER		359.22
	Invoice		Date	Description		Amount
		03032016	03/03/2016	FIRST AID PRODUCTS FOR THE SENIOR CENTER		147.78
		03032016	03/03/2016	REFILL FIRST AID KIT - BUILDING SAFETY DIV		211.44
Check	05/26/2016	75407	Accounts Payable	GILA ELECTRONIC		316.80
	Invoice		Date	Description		Amount
		3134	05/03/2016	NEW BATTERY/CHARGER FOR EE#542 & EE#623		316.80
Check	05/26/2016	75408	Accounts Payable	GONZALEZ , JOHNATTAN		200.00
	Invoice		Date	Description		Amount
		3	05/07/2016	PAYMENT FOR DJ SERVICES RENDERED AT THE GESD SPECIAL OLYMPICS		200.00
Check	05/26/2016	75409	Accounts Payable	GREATER YUMA ECONOMIC DEV CORP		8,125.00
	Invoice		Date	Description		Amount
		2015-306	04/18/2016	4TH QTR INVESTMENT IN GREATER YUMA 15/16		8,125.00
Check	05/26/2016	75410	Accounts Payable	GUZMAN , FRANCISCA		50.00
	Invoice		Date	Description		Amount
		7/2016	05/11/2016	TRANSLATING SERVICES FOR COUNIL MEETING 051116		50.00
Check	05/26/2016	75411	Accounts Payable	HOYOS, LUZ E.		100.00
	Invoice		Date	Description		Amount
		0002	04/12/2016	TRANSLATION SERVICES FOR PLANNING/ZONING		100.00
Check	05/26/2016	75412	Accounts Payable	IMLA		625.00
	Invoice		Date	Description		Amount
		19867140	05/02/2016	MEMBERSHIP RENEWAL		625.00
Check	05/26/2016	75413	Accounts Payable	INTERNATIONAL BUSINESS INNOVATION ASSOCIATION		525.00
	Invoice		Date	Description		Amount
		110000	05/24/2016	MEMBERSHIP RENEWAL		525.00
Check	05/26/2016	75414	Accounts Payable	JAMES DAVEY AND ASSOCIATES		4,032.00
	Invoice		Date	Description		Amount

City of San Luis  
**Payment Batch Register**  
 Bank Account: 1BYPAYABLE - 1st BY Accounts Payable  
 Batch Date: 05/26/2016

Type	Date	Number	Source	Payee Name	EFT Bank/Account	Transaction Amount
		00002015241		05/10/2016	ENGINEERING SERVICES FOR CDBG #107-16	4,032.00
Check	05/26/2016	75415	Accounts Payable	L.N. CURTIS & SONS		1,642.08
		Invoice		Date	Description	Amount
		502326-00		02/24/2016	ROUTINE ANNUAL SERVICE FOR MAKO BREATHING AIR COMPRESSOR	1,642.08
Check	05/26/2016	75416	Accounts Payable	LAWSON PRODUCTS INC.		169.84
		Invoice		Date	Description	Amount
		9304069906		05/03/2016	PURCHASE OF BOLTS FOR WASTEWATER DEPT VIN# 2467 & 8771	93.24
		9304085825		05/10/2016	PURCHASE OF AUTOMOTIVE PARTS FOR FIRE DEPT VIN# 8313	76.60
Check	05/26/2016	75417	Accounts Payable	LEERS		70.84
		Invoice		Date	Description	Amount
		2016-00001076		05/24/2016	SPONSOR BANNER FOR ED SUMMIT	70.84
Check	05/26/2016	75418	Accounts Payable	LESLIE'S POOL SUPPLY INC.		247.74
		Invoice		Date	Description	Amount
		293-377982		05/09/2016	PURCHASED CHEMICALS FOR AQUATIC CENTER POOL	247.74
Check	05/26/2016	75419	Accounts Payable	LOOMIS		1,125.25
		Invoice		Date	Description	Amount
		11804569		04/30/2016	ARMORED CAR SERVICE, FUEL & INSURANCE FEES	1,125.25
Check	05/26/2016	75420	Accounts Payable	MACHADO MADRID , FRANCISCO ROGELIO		1,300.00
		Invoice		Date	Description	Amount
		051216		05/12/2016	SERVICES RENDERED FOR SPRING PRESENTATION ON MAY 12	250.00
		050516		05/05/2016	SERVICES RENDERED FOR MOTHERS DAY ON MAY 05	250.00
		042716		04/27/2016	SERVICES RENDERED ON DIA DEL NINO ON APRIL 27, 2016	400.00
		040816		04/08/2016	SERVICES RENDERED FOR MOVIE NIGHT AT JOE ORDUNO PARK	400.00
Check	05/26/2016	75421	Accounts Payable	MARTINEZ, JOSE ALFREDO		140.00
		Invoice		Date	Description	Amount
		2016-00001081		05/25/2016	SERVICES RENDERED FOR UMPIRE OF YOUTH BASEBALL LEAGUE SPRING2016	140.00
Check	05/26/2016	75422	Accounts Payable	MCNEECE BROS. OIL COMPANY, INC		954.37

City of San Luis  
**Payment Batch Register**

Bank Account: 1BYPAYABLE - 1st BY Accounts Payable  
 Batch Date: 05/26/2016

Type	Date	Number	Source	Payee Name	EFT Bank/Account	Transaction Amount	
				Invoice	Date	Description	Amount
				517887	05/05/2016	PURCHASE OF 10W30\ OIL FOR SOLID WASTE DEPT VIN #3270 & 4813	954.37
Check	05/26/2016	75423	Accounts Payable	MEDINA, JOSE			80.00
				Invoice	Date	Description	Amount
				2016-00001077	05/25/2016	SERVICES RENDERED OF UMPIRE FOR YOUTH BASEBALL LEAGUE 2016	80.00
Check	05/26/2016	75424	Accounts Payable	NAPA AUTO PARTS			122.48
				Invoice	Date	Description	Amount
				178-185022	05/25/2016	CREDIT	(85.33)
				178-410246	05/25/2016	CREDIT	(72.19)
				252274	04/27/2016	REPAIR OF AUTOMOTIVE PARTS FOR POLICE DEPT VIN# 4494	280.00
Check	05/26/2016	75425	Accounts Payable	OFFICE DEPOT			2,782.31
				Invoice	Date	Description	Amount
				837075280001	05/04/2016	OFFICE SUPPLIES FOR UTILITIES	272.35
				832804498001	04/13/2016	OFFICE SUPPLIES FOR BUSINESS INCUBATOR	22.43
				832804495001	04/14/2016	OFFICE SUPPLIES FOR BUSINESS INCUBATOR	198.64
				832804497001	04/13/2016	OFFICE SUPPLIES FOR BUSINESS INCUBATOR	10.85
				832804496001	04/14/2016	OFFICE SUPPLIES FOR BUSINESS INCUBATOR	10.63
				834996244001	04/12/2016	OFFICE SUPPLIES FOR YOUTH CENTER	25.15
				836696009001	05/04/2016	OFFICE SUPPLIES FOR PW	8.67
				836695715001	05/04/2016	OFFICE SUPPLIES FOR PW	90.76
				819605689001	01/27/2016	OFFICE SUPPLIES FOR COURT	48.83
				821921683001	02/11/2016	OFFICE SUPPLIES FOR COURT	136.62
				829101794001	03/24/2016	OFFICE SUPPLIES FOR COURT	337.77
				830749495001	03/22/2016	OFFICE SUPPLIES FOR PW	6.51
				830749009001	03/22/2016	OFFICE SUPPLIES FOR PW	259.37
				832291901001	04/06/2016	OFFICE SUPPLIES FOR COUNCIL	8.68
				832291899001	04/06/2016	OFFICE SUPPLIES FOR COUNCIL	113.98
				832291841001	04/06/2016	OFFICE SUPPLIES FOR COUNCIL	56.18
				834996146001	04/13/2016	OFFICE SUPPLIES FOR YOUTH CENTER	393.63
				833427491001	04/11/2016	OFFICE SUPPLIES FOR FINANCE	80.60
				835089930001	04/13/2016	OFFICE SUPPLIES FOR CITY CLERK	28.54
				832291900001	04/07/2016	OFFICE SUPPLIES FOR COUNCIL	13.93

City of San Luis  
**Payment Batch Register**  
 Bank Account: 1BYPAYABLE - 1st BY Accounts Payable  
 Batch Date: 05/26/2016

Type	Date	Number	Source	Payee Name	EFT Bank/Account	Transaction Amount
		835090134001		04/14/2016	OFFICE SUPPLIES FOR CITY CLERK	14.79
		835090133001		04/14/2016	OFFICE SUPPLIES FOR CITY CLERK	59.45
		835195319001		04/14/2016	OFFICE SUPPLIES FOR POLICE	292.00
		835195805001		04/14/2016	OFFICE SUPPLIES FOR POLICE	6.48
		835195804001		04/14/2016	OFFICE SUPPLIES FOR POLICE	4.12
		835195803001		04/15/2016	OFFICE SUPPLIES FOR POLICE	40.14
		834122711001		04/21/2016	OFFICE SUPPLIES FOR FIRE	49.42
		833836024001		04/21/2016	OFFICE SUPPLIES FOR FINANCE	11.49
		833836025001		04/21/2016	OFFICE SUPPLIES FOR FINANCE	180.30
Check	05/26/2016	75426	Accounts Payable	ON TRACK OVERHEAD DOORS		125.00
		Invoice		Date	Description	Amount
		4495		05/10/2016	DOOR REPAIR AT PD	125.00
Check	05/26/2016	75427	Accounts Payable	PAUL CONWAY SHIELDS		146.47
		Invoice		Date	Description	Amount
		0381549-IN		03/17/2016	4" PASSPORT SHIELD W/ 2 PANELS, TOP/BOTTOM	146.47
Check	05/26/2016	75428	Accounts Payable	PROFESSIONAL PEST CONTROL LLC		85.00
		Invoice		Date	Description	Amount
		1594		05/19/2016	PIGEON CONTROL SERVICES @BUSINESS INCUBATOR	40.00
		1588		05/19/2016	PEST CONTROL @BUSINESS INCUBATOR	45.00
Check	05/26/2016	75429	Accounts Payable	PUBLIC SAFETY CENTER, INC		103.06
		Invoice		Date	Description	Amount
		5669324		04/27/2016	NITRILE GLOVES, PRINT PADS FOR SLPD	103.06
Check	05/26/2016	75430	Accounts Payable	R.J. SAFETY SUPPLY CO. INC.		216.00
		Invoice		Date	Description	Amount
		354603-2		03/24/2016	SAFETY SUPPLIES FOR HWY USERS CREW & AZ STATE INMATES	216.00
Check	05/26/2016	75431	Accounts Payable	RAMIREZ, KASSANDRA		1,200.00
		Invoice		Date	Description	Amount
		2016-00001083		05/25/2016	TUITION REIMBURSEMENT	1,200.00
Check	05/26/2016	75432	Accounts Payable	RAMON MOSQUEDA		84.00
		Invoice		Date	Description	Amount

City of San Luis  
**Payment Batch Register**  
 Bank Account: 1BYPAYABLE - 1st BY Accounts Payable  
 Batch Date: 05/26/2016

Type	Date	Number	Source	Payee Name	EFT Bank/Account	Transaction Amount
		1467		05/16/2016	EMBROIDERY	84.00
Check	05/26/2016	75433	Accounts Payable	RDO EQUIPMENT CO.		1,942.25
		Invoice		Date	Description	Amount
		W42593		04/29/2016	PAYMENT WAS FOR REPAIR DONE ON JOHN DEERE TRACTOR	1,104.76
		P15034		04/20/2016	PURCHASE OF EQUIPMENT FOR HWY USER DEPT VIN# 1071	458.29
		P15417		04/26/2016	PURCHASE OF PARTS FOR PARKS DEPT VIN# 5437	270.56
		P16674		05/13/2016	PURCHASE OF PARTS FOR HWY USERS DEPT EQUIPMENT VIN# 2118	108.64
Check	05/26/2016	75434	Accounts Payable	REAL PURIFIED WATER LLC		83.10
		Invoice		Date	Description	Amount
		12928		04/04/2016	SLFD DRINKING WATER FROM APRIL 2016	25.50
		12998		04/13/2016	SLFD DRINKING WATER FROM APRIL 2016	21.00
		13629		04/20/2016	SLFD DRINKING WATER FROM APRIL 2016	15.00
		13742		04/20/2016	SLFD DRINKING WATER FROM APRIL 2016	9.00
		13888		04/26/2016	SLFD DRINKING WATER FROM APRIL 2016	12.60
Check	05/26/2016	75435	Accounts Payable	REDBURN TIRE COMPANY		3,378.92
		Invoice		Date	Description	Amount
		11017995		04/29/2016	PURCHASE OF TIRES FOR PARKS DEPT VIN# 0848	544.25
		11018109		05/03/2016	PURCHASE OF TIRES FOR WASTEWATER DEPT VIN# 7862	736.30
		11018108		05/03/2016	PURCHASE OF TIRES FOR PARKS DEPT VIN# 4166	260.18
		11018079		05/02/2016	PURCHASE OF TIRES FOR WATER DEPT VIN#2487	396.74
		11017990		04/29/2016	PURCHASE OF TIRES FOR POLICE DEPT VIN# 4450	543.25
		11018231		05/18/2016	PURCHASE OF TIRES FOR POLICE DEPT VIN# 5713	490.52
		11018311		05/19/2016	PURCHASE OF TIRES FOR POLIDE DEPT VIN# 7758	407.68
Check	05/26/2016	75436	Accounts Payable	RIVERA , MARIA ELENA		75.00
		Invoice		Date	Description	Amount
		CR.2015.00022		05/24/2016	RESTITUTION	75.00
Check	05/26/2016	75437	Accounts Payable	RODRIGUEZ , JANNET		50.00
		Invoice		Date	Description	Amount
		CR2015000364		05/24/2016	RESTITUTION	50.00
Check	05/26/2016	75438	Accounts Payable	RUIZ , GLENDA		75.00

City of San Luis  
**Payment Batch Register**  
 Bank Account: 1BYPAYABLE - 1st BY Accounts Payable  
 Batch Date: 05/26/2016

Type	Date	Number	Source	Payee Name	EFT Bank/Account	Transaction Amount
				Invoice	Date	Amount
				0001	04/30/2016	
					PHOTOGRAPHY SERVICES RENDERED FOR FUN RUN/WALK 3K/5K EVENT	75.00
Check	05/26/2016	75439	Accounts Payable	SALDANA VIERA , JESSICA		75.00
				Invoice	Date	Amount
				0001	04/30/2016	
					PHOTOGRAPHY SERVICES RENDERED FOR THE FUN WALK/RUN 3K/5K EVENT	75.00
Check	05/26/2016	75440	Accounts Payable	SAN LUIS AIR CONDITIONING LLC		5,430.00
				Invoice	Date	Amount
				16-214	04/06/2016	50.00
				16-218	04/06/2016	50.00
				16-097	04/06/2016	150.00
				16-095	04/06/2016	970.00
				16-216	04/06/2016	250.00
				16-100	04/06/2016	50.00
				16-098	04/06/2016	1,150.00
				16-099	04/06/2016	900.00
				16-221	04/06/2016	250.00
				16-096	04/06/2016	300.00
				16-220	04/06/2016	200.00
				16-101	04/06/2016	150.00
				16-213	04/06/2016	150.00
				16-212	04/06/2016	100.00
				16-215	04/06/2016	150.00
				16-217	04/06/2016	560.00
Check	05/26/2016	75441	Accounts Payable	SAN LUIS AZ NEWS		1,612.00
				Invoice	Date	Amount
				5848	03/18/2016	676.00
				5872	04/22/2016	936.00
Check	05/26/2016	75442	Accounts Payable	SENSUS METERING SYSTEMS		1,825.91
				Invoice	Date	Amount
				ZA17001234	04/28/2016	1,825.91
Check	05/26/2016	75443	Accounts Payable	SIGN MASTERS		656.87

City of San Luis  
**Payment Batch Register**  
 Bank Account: 1BYPAYABLE - 1st BY Accounts Payable  
 Batch Date: 05/26/2016

Type	Date	Number	Source	Payee Name	EFT Bank/Account	Transaction Amount
	Invoice			Date	Description	Amount
		39852		04/28/2016	PURCHASE OF VARIOUS LETTERING FOR WASTEWATER DEPT VINS 8771&2467	344.32
		39874		05/03/2016	PURCHASE OF VARIOUS LETTERING FOR HWY USERS DEPT VIN# 1277	312.55
Check	05/26/2016	75444	Accounts Payable	SIRCHIE FINGER PRINT LABORATORIES		162.05
	Invoice			Date	Description	Amount
		0253907-IN		05/12/2016	SUPPLIES FOR PD	162.05
Check	05/26/2016	75445	Accounts Payable	SMITH, RALPH E. SR.		750.00
	Invoice			Date	Description	Amount
		23955		04/30/2016	MICROBIOLOGICAL ANALYSIS - COMPLIANCE TESTING - APRIL 1-15 2016	375.00
		23983		04/30/2016	MICROBIOLOGICAL ANALYSIS - COMPLIANCE TESTING - APRIL 2ND 2016	375.00
Check	05/26/2016	75446	Accounts Payable	SOCIETY FOR HUMAN RESOURCE MGMT		190.00
	invoice			Date	Description	Amount
		001621264		05/25/2016	GENERAL ANNUAL MEMBERSHIP	190.00
Check	05/26/2016	75447	Accounts Payable	SOUTH YUMA COUNTY LANDFILL		12,805.91
	Invoice			Date	Description	Amount
		8415		05/01/2016	LANDFILL FEES FROM - 041816-042916	12,805.91
Check	05/26/2016	75448	Accounts Payable	SOUTHWEST ENTRANCES, INC		9,489.00
	Invoice			Date	Description	Amount
		119487		05/16/2016	INSTALL HANDICAP ACCESSIBLE DOOR SWITCH AT GYM	2,998.00
		119486		05/16/2016	INSTALL HANDICAP ACCESSIBLE DOOR SWITCH AT CULTURAL CENTER	2,998.00
		119485		05/16/2016	INSTALL HANDICAP ACCESSIBLE DOOR SWITCH AT YOUTH CENTER	2,998.00
		119378		04/28/2016	REPAIR ENTRANCE DOORS AT CULTURAL CENTER	495.00
Check	05/26/2016	75449	Accounts Payable	STANDARD INSURANCE CO.		6,468.23
	Invoice			Date	Description	Amount
		MAY 2016 LI		05/24/2016	LIFE INSURANCE MAY 2016	6,468.23
Check	05/26/2016	75450	Accounts Payable	STANDARD PRINTING COMPANY, INC		1,241.30
	Invoice			Date	Description	Amount

City of San Luis  
**Payment Batch Register**  
 Bank Account: 1BYPAYABLE - 1st BY Accounts Payable  
 Batch Date: 05/26/2016

Type	Date	Number	Source	Payee Name	EFT Bank/Account	Transaction Amount
		246529		05/05/2016	OUTSOURCE FOR PRINTING/PREPARING MONTHLY UTILITY BILL	1,241.30
Check	05/26/2016	75451	Accounts Payable	THE UPS STORE		92.14
	Invoice		Date	Description		Amount
		2269		04/14/2016	SHIPPING AND HANDLING FOR VARIOUS DEPARTMENTS	37.76
		2271		04/15/2016	SHIPPING AND HANDLING FOR VARIOUS DEPARTMENTS	32.69
		2273		04/20/2016	SHIPPING AND HANDLING FOR VARIOUS DEPARTMENTS	12.47
		2277		04/26/2016	SHIPPING AND HANDLING FOR VARIOUS DEPARTMENTS	9.22
Check	05/26/2016	75452	Accounts Payable	THOMSON WEST PUBLISHING CO.		732.35
	Invoice		Date	Description		Amount
		833927300		05/01/2016	INTERNET SERVICES FOR APRIL 2016	732.35
Check	05/26/2016	75453	Accounts Payable	TORRES , CRISTIAN		175.00
	Invoice		Date	Description		Amount
		42216		05/02/2016	RENTAL OF CHAIRS & TABLES FOR BUSINESS EXPO EVENT ON APRIL 20-21	175.00
Check	05/26/2016	75454	Accounts Payable	TYLER TECHNOLOGIES, INC		985.00
	Invoice		Date	Description		Amount
		049584		04/27/2016	AEGIS CONFERENCE FOR D.DUENAS	985.00
Check	05/26/2016	75455	Accounts Payable	ULINE, INC.		574.18
	Invoice		Date	Description		Amount
		76625790		05/03/2016	SUPPLIES FOR PD	193.45
		76544296		04/28/2016	SUPPLIES FOR PD	380.73
Check	05/26/2016	75456	Accounts Payable	UNITED RENTALS (NORTH AMERICA), INC.		317.62
	Invoice		Date	Description		Amount
		135750959-001		03/14/2016	RENTAL OF GENERATORS FOR RELAY FOR LIFE HELD ON MARCH 11-12	456.35
		135750959-002		03/31/2016	CREDIT	(138.73)
Check	05/26/2016	75457	Accounts Payable	UNITED ROTARY BRUSH		1,198.47
	Invoice		Date	Description		Amount
		C1185090		04/29/2016	PURCHASE OF AUTO PARTS FOR HIGHWAY USER DEPT VIN#3580 & 5204	1,198.47
Check	05/26/2016	75458	Accounts Payable	UNIVERSAL BACKGROUND SCREENING INC		212.00

City of San Luis  
**Payment Batch Register**  
 Bank Account: 1BYPAYABLE - 1st BY Accounts Payable  
 Batch Date: 05/26/2016

Type	Date	Number	Source	Payee Name	EFT Bank/Account	Transaction Amount
	Invoice		Date	Description		Amount
		201604001962	04/30/2016	BACKGROUND CHECKS FOR NEW HIRES/VOLUNTEERS		212.00
Check	05/26/2016	75459	Accounts Payable	URQUIJO LASTRA, SALVADOR		260.00
	Invoice		Date	Description		Amount
		2016-00001079	05/25/2016	SERVICES RENDERED OF UMPIRE FOR MEN'S SOFTBALL LEAGUE 2015		260.00
Check	05/26/2016	75460	Accounts Payable	US POST MASTER		2,426.48
	Invoice		Date	Description		Amount
		125874	05/05/2016	MONTHLY POSTAGE FOR UTILITY BILL MAILING		2,426.48
Check	05/26/2016	75461	Accounts Payable	VILLALPANDO , YENNY I		120.00
	Invoice		Date	Description		Amount
		2016-00001078	05/25/2016	SERVICES RENDERED FOR SCOREKEEPER FOR YOUTH BASEBALL LEAGUE 2016		120.00
Check	05/26/2016	75462	Accounts Payable	VILLAR, GLORIA		50.00
	Invoice		Date	Description		Amount
		CR 2014 00081	05/24/2016	RESTITUTION		50.00
Check	05/26/2016	75463	Accounts Payable	VIVEROS LOS PINOS		574.55
	Invoice		Date	Description		Amount
		0611	04/19/2016	PURCHASE OF TREES & BUSHES FOR TRES HOMBRES PROJECT		574.55
Check	05/26/2016	75464	Accounts Payable	WAGGIN WEST KENNELS AND GROOMING CENTER		43.20
	Invoice		Date	Description		Amount
		658244	04/05/2016	K9 DENIS BOARDING 3 DAYS		43.20
Check	05/26/2016	75465	Accounts Payable	WAXIE SANITARY SUPPLY		2,824.56
	Invoice		Date	Description		Amount
		75940117	04/27/2016	PURCHASE OF CLEANING SUPPLIES FOR THE AQUATIC CENTER		157.37
		75940116	04/27/2016	PURCHASE OF JANITORIAL SUPPLIES FOR PARKS RESTROOMS		1,249.36
		75965651	05/10/2016	PURCHASE OF BATTERIES FOR BURNISHER MACHINE		1,417.83
Check	05/26/2016	75466	Accounts Payable	WAYLON'S WATER WORLD LLC		8,750.00
	Invoice		Date	Description		Amount

City of San Luis  
**Payment Batch Register**  
 Bank Account: 1BYPAYABLE - 1st BY Accounts Payable  
 Batch Date: 05/26/2016

Type	Date	Number	Source	Payee Name	EFT Bank/Account	Transaction Amount
		234		05/25/2016	2016 EMPLOYEE PICNIC	8,750.00
Check	05/26/2016	75467	Accounts Payable	YUMA COUNTY PUBLIC HEALTH		216.00
	Invoice		Date	Description		Amount
		A160306		05/02/2016	VACCINES	216.00
Check	05/26/2016	75468	Accounts Payable	YUMA COUNTY RECORDER'S OFFICE		285.50
	Invoice		Date	Description		Amount
		16-5802		04/05/2016	RECORDING FEES FOR CLERK'S OFFICE	55.50
		16-6812		04/21/2016	RECORDING FEES FOR CLERK'S OFFICE	16.00
		16-7306		04/28/2016	RECORDING FEES FOR CLERK'S OFFICE	214.00
Check	05/26/2016	75469	Accounts Payable	YUMA ELECTRIC MOTORS & PUMPS		1,760.43
	Invoice		Date	Description		Amount
		16215		05/17/2016	REPAIR MIXER 1 'B' FOR BASIN #1 AT WEST WWTP	1,760.43
Check	05/26/2016	75470	Accounts Payable	YUMA HEALTH CARE SERVICES, INC		260.70
	Invoice		Date	Description		Amount
		59661		03/04/2016	M TANK REFILLS FOR SLFD FROM 2/10/16	102.03
		60866		04/07/2016	OXYGEN TANK REFILLS FOR SLFD	158.67
Check	05/26/2016	75471	Accounts Payable	YUMA NURSERY SUPPLY		5,828.31
	Invoice		Date	Description		Amount
		283824		05/04/2016	PURCHASE OF PLANTS NEEDED FOR LOS TRES HOMBRES PROJECT-PARKS DEP	41.87
		283685		05/02/2016	PURCHASE OF MATERIAL FOR LOS TRES HOMBRES PROJECT - PARKS DEPT	4,229.94
		282682		04/13/2016	PURCHASE WAS MADE FOR THE REPLACEMENT OF PLANTS AT CITY HALL	65.05
		283332		04/25/2016	PURCHASE OF MATERIALS FOR TRES HOMBRES PROJECT FROM PARKS DEPT	84.89
		283235		04/22/2016	PURCHASE OF MATERIALS FOR TRES HOMBRES PROJECT FROM PARKS DEPT	353.80
		283973		05/06/2016	PURCHASE OF IRRIGATION LINES FOR LOS TRES HOMBRES PROJECT	49.45
		283384		04/26/2016	PURCHASE OF IRRIGATION MATERIALS FOR TRES HOMBRES PROJECT	153.74
		282258		04/05/2016	PURCHASE OF IRRIGATION REPAIR MATERIALS FOR LOS TRES HOMBRES	315.58
		284613		05/19/2016	PURCHASE OF GRASS FOR ONE OF RECREATIONS FIELDS	344.75
		284614		05/19/2016	SLPD LANDSCAPING	189.24
Check	05/26/2016	75472	Accounts Payable	YUMA PRINTING & GRAPHIC DEPT.		1,460.89
	Invoice		Date	Description		Amount

City of San Luis  
**Payment Batch Register**  
 Bank Account: 1BYPAYABLE - 1st BY Accounts Payable  
 Batch Date: 05/26/2016

Schedule J

Type	Date	Number	Source	Payee Name	EFT Bank/Account	Transaction Amount
		8908		05/04/2016	COLLISION INFO FORMS	392.70
		8924		05/05/2016	BUSINESS CARDS FOR M SABORI	108.85
		8953		05/12/2016	VEHICLE REPORT FORMS	959.34
Check	05/26/2016	75473	Accounts Payable	YUMA REGIONAL MEDICAL CENTER		5,292.32
		Invoice		Date	Description	Amount
		2808		02/05/2016	PHARMACY CHARGES FROM JANUARY 2016	909.80
		2856		02/29/2016	PHARMACY CHARGES FROM FEBRUARY 2016	2,226.05
		2896		03/31/2016	PHARMACY CHARGES FROM MARCH 2016	2,156.47
Check	05/26/2016	75474	Accounts Payable	YUMA SUN, INC		1,120.13
		Invoice		Date	Description	Amount
		00093253		05/20/2016	POLICE OFFICER AD	399.00
		0009314		04/15/2016	PAYMENT FOR PUBLICITY & ADVERTISEMENT FOR DIA DEL NINO 2016	349.00
		00009314		04/22/2016	PAYMENT FOR PUBLICITY & ADVERTISEMENT FOR SOUTH COUNTY BEST 2015	349.00
		000009314		04/30/2016	SERVICE CHARGE	23.13
Check	05/26/2016	75475	Accounts Payable	YUMA WINNELSON CO.		2,538.00
		Invoice		Date	Description	Amount
		271638 00		05/05/2016	REPLACE PVC LINE F/ CHLORINATION SYSTEM@BOTH WWTPs	347.24
		270007 00		04/27/2016	MATERIAL F/ NEW INSTALLATIONS AND/OR REPAIRS OF WTR DIST. SYSTEM	2,190.76
1BYPAYABLE 1st BY Accounts Payable Totals:				Transactions: 97		\$168,211.35

Checks: 97 \$168,211.35

Prepared By:  
*Maggie Dominguez*  
 Date: *Maggie*  
*5/26/16*  

City of San Luis  
**Payment Batch Register**  
 Bank Account: 1BYPAYABLE - 1st BY Accounts Payable  
 Batch Date: 05/26/2016

Schedule K

Type	Date	Number	Source	Payee Name	EFT Bank/Account	Transaction Amount
<b>Bank Account: 1BYPAYABLE - 1st BY Accounts Payable</b>						
Check	05/26/2016	75476	Accounts Payable	ARIZONA DEPARTMENT OF REVENUE / TPT		1,604.63
		<u>Invoice</u>		<u>Date</u>	<u>Description</u>	<u>Amount</u>
		16016856434		05/26/2016	TAX CORRECTION NOTICE	1,604.63
Check	05/26/2016	75477	Accounts Payable	ARIZONA PUBLIC SERVICE		1,783.46
		<u>Invoice</u>		<u>Date</u>	<u>Description</u>	<u>Amount</u>
		785728287MAY16		05/10/2016	ELECTRICITY - 415 INDUSTRIAL AVE (7LOCATIONS) & HSE PNL H	896.22
		181722289MAY16		05/26/2016	ELECTRICITY - MULTIPLE ACCOUNTS	887.24
Check	05/26/2016	75478	Accounts Payable	GARCIA-BONILLA, ELIZABETH		216.00
		<u>Invoice</u>		<u>Date</u>	<u>Description</u>	<u>Amount</u>
		GB 051616		05/12/2016	TRAVEL - CERTIFIED PUBLIC MANAGER PRGM	108.00
		GB 04252016		04/21/2016	TRAVEL - CERTIFIED PUBLIC MANAGER PRGM	108.00
Check	05/26/2016	75479	Accounts Payable	LIBERTY MOTORSPORTS		662.76
		<u>Invoice</u>		<u>Date</u>	<u>Description</u>	<u>Amount</u>
		96598317		05/05/2016	INSTALLATION OF BRAKE PADS ON POLICE DEPT VIN# 0051	515.65
		96617734		05/12/2016	PURCHASE OF AUTOMOTIVE PARTS FOR POLICE DEPT VIN# 0066	147.11
Check	05/26/2016	75480	Accounts Payable	LUNA, ENRIQUE		106.82
		<u>Invoice</u>		<u>Date</u>	<u>Description</u>	<u>Amount</u>
		LUNA 052616		05/26/2016	REIMBURSEMENT - UNIFORM SHIRTS	106.82
Check	05/26/2016	75481	Accounts Payable	TRANSWESTERN INSURANCE ADMIN		299.40
		<u>Invoice</u>		<u>Date</u>	<u>Description</u>	<u>Amount</u>
		2016-00001088		05/26/2016	INSURANCE FOR APRIL 2016	299.40
Check	05/26/2016	75482	Accounts Payable	VARGAS, HERIBERTO		97.56
		<u>Invoice</u>		<u>Date</u>	<u>Description</u>	<u>Amount</u>
		VARGAS 052616		05/26/2016	REIMBURSEMENT - STEEL TOE BOOTS	97.56
1BYPAYABLE 1st BY Accounts Payable Totals:				Transactions: 7		\$4,770.63
Checks:		7				\$4,770.63

Prepared By:  
*Maggie Dominguez*  
 Date: *Maggie* 5/26/16

City of San Luis  
**Payment Batch Register**  
 Bank Account: 1BYPAYABLE - 1st BY Accounts Payable  
 Batch Date: 05/26/2016

Schedule L

Type	Date	Number	Source	Payee Name	EFT Bank/Account	Transaction Amount
<b>Bank Account: 1BYPAYABLE - 1st BY Accounts Payable</b>						
Check	05/26/2016	75483	Accounts Payable	AZ STATE PRISON COMPLEX - YUMA		294.00
	Invoice		Date	Description		Amount
		Y0810920160512	05/13/2016	TRANSPORTATION PROJECT		294.00
Check	05/26/2016	75484	Accounts Payable	AZ STATE PRISON COMPLEX - YUMA		89.00
	Invoice		Date	Description		Amount
		Y0810920160428	04/29/2016	TRANSPORTATION PROJECT		89.00
Check	05/26/2016	75485	Accounts Payable	AZ STATE PRISON COMPLEX - YUMA		89.00
	Invoice		Date	Description		Amount
		Y08-109 20160512	05/13/2016	LABOR PROJECT		89.00
Check	05/26/2016	75486	Accounts Payable	AZ STATE PRISON COMPLEX - YUMA		291.00
	Invoice		Date	Description		Amount
		Y08-109 20160428	04/29/2016	INMATE LABOR PROJECT		291.00
Check	05/26/2016	75487	Accounts Payable	PETTY CASH/AQUATIC		100.00
	Invoice		Date	Description		Amount
		2016-00001089	05/26/2016	PETTY CASH NEEDED FOR THE AQUATIC CENTER POOL REGISTER BOX		100.00
1BYPAYABLE 1st BY Accounts Payable Totals:				Transactions: 5		\$863.00
Checks:		5		\$863.00		

Prepared By:  
*Maggie Dominguez*  
 Date: *Maggie*  
*5/26/16*  



## AGENDA ITEM REVIEW FORM

### Regular City Council Meeting

4. C.

**Meeting Date:** 06/08/2016

**Department Head:** Kay Macuil, City Attorney, Attorney's Office

**Submitted By:** Kay Macuil, City Attorney, Attorney's Office

**Action Requested:** Motion  
Resolution

---

### ITEM:

Discussion and possible action on any and all matters regarding the adoption of Resolution No. 1148. A resolution of the Mayor and Council of the City of San Luis, Arizona, authorizing the City Manager to amend the Classification and 2006 Salary Plan of the City of San Luis; create certain positions; and make other personnel and departmental changes to include transfers within the organization, in preparation for fiscal year 2016-2017. **(Tadeo A. De La Hoya, Interim City Manager)**

### SUMMARY:

The City had its annual budget workshop on April 15 and 16, 2016 and at that time, the proposed 2016-2017 budget showed a deficit of \$8.4 million. The attached resolution directs the City Manager to make the necessary changes in the proposed budget in order to balance the fiscal year 2016-2017 budget.

In anticipation of a significant reduction in City generated revenues, and to ensure that City expenses do not exceed revenues, this resolution authorizes the City Manager to amend the Classification and 2006 Salary Plan of the City; reduce or eliminate the accrual of overtime; eliminate all non-critical expenditures; with the exception of the Municipal Court, to transfer employees within the organization; and plan for potential layoffs and conversion of positions within the classified service in preparation for fiscal year 2016-2017.

### RECOMMENDATION / SUGGESTED MOTION:

**I MOVE TO APPROVE AND ADOPT RESOLUTION NO. 1148.**

### Supporting information not attached to the Agenda Item Review Form:

Supporting information is attached.

**Document to be Recorded?:** Yes

**City Clerk's Office**

---

**Fiscal Impact**

**IS THERE FISCAL IMPACT ASSOCIATED WITH THIS ITEM:** N/A  
**CITY/STATE/FEDERAL FUNDS:** N/A  
**TOTAL:** N/A  
**BUDGETED:** N/A  
**AVAILABLE TO TRANSFER:** N/A  
**GL ACCT # & NAME/REMAINING BALANCE BEFORE PURCHASE:** N/A

**FISCAL IMPACT STATEMENT (IF THIS IS A BUDGET TRANSFER, YOU MUST ATTACH THE BUDGET ADJUSTMENT FORM):**

Depending upon the particular actions there will be a fiscal impact cutting back expenses. Exact amounts are not yet known.

---

**Attachments**

Resolution No. 1148

---



# *Resolution*

NO. 1148

OFFICE OF THE  
MAYOR  
CITY OF SAN LUIS

**A RESOLUTION OF THE MAYOR AND COUNCIL OF THE CITY OF SAN LUIS, ARIZONA, AUTHORIZING THE CITY MANAGER TO AMEND THE CLASSIFICATION AND 2006 SALARY PLAN OF THE CITY OF SAN LUIS; CREATE CERTAIN POSITIONS; AND MAKE OTHER PERSONNEL AND DEPARTMENTAL CHANGES TO INCLUDE TRANSFERS WITHIN THE ORGANIZATION, IN PREPARATION FOR FISCAL YEAR 2016-2017**

**WHEREAS**, in order to provide for the most efficient delivery of service to the citizens of the City of San Luis and to maintain sound financial structure for the city in its finances and operations, it has been determined that certain amendments to the Classification and 2006 Salary Plan of the City of San Luis and reorganization of the city departments and divisions has become necessary;

**WHEREAS**, the City could experience a dramatic short-fall in business license revenue in the fiscal year 2016-2017 and the City needs to have a plan in place for such possible short-fall;

**NOW, THEREFORE, BE IT RESOLVED** by the Mayor and Council of the City of San Luis, Arizona:

**Section 1:** The City Manager is hereby directed to prepare appropriate amendments to the Classification and 2006 Salary Plan of the City of San Luis in accordance with the provisions of this resolution as part of the budget process for fiscal year 2016-2017.

The changes are to be as follows:

- a) The Development Services Division and the Building Safety Division shall be removed from the Public Works Department and is hereby transferred to be under the Planning and Zoning Department which shall be directly under City Administration. The Building Safety Director position will be converted to the Planning and Zoning Director.
- b) The City Prosecutor shall no longer be a contracted position. The City Prosecutor shall be a salaried position as part of the Classification and Salary Plan effective August 18, 2016.

**Section 2:** The City Manager is hereby authorized and directed to take such steps as may be needed or necessary to reduce, suspend, or eliminate the accrual of overtime in all city departments, with the exception of overtime as actually paid by federal or state grants. It is the legislative intent of the City Council to specifically disallow regular paid overtime until July 1, 2017.

**Section 4:** The City Manager is hereby directed to take such acts or actions as may be needed or necessary with respect to reduce or eliminate all non-critical non-emergency expenditures of the city to ensure that expenditures do not exceed available funds for fiscal year 2016-2017.

**Section 5:** The City Manager is authorized and directed to counsel with employees who may wish to seek early retirement or otherwise leave the city service and negotiate such severance or other agreements that he deems appropriate for the consideration of City Council.

**Section 6:** The City Manager is hereby directed and authorized to prepare and implement if necessary guidelines and a plan pursuant to Section 8.03 of the City of San Luis Personnel Policies, dated July 1, 2008, to lay-off full-time positions within the Classification and 2006 Salary Plan of the City of San Luis and to convert full-time positions to part-time positions as may be needed due to possible business license revenue short-falls. The positions that would be subject to layoff and conversion if there is such a shortfall would not be eliminated nor would such action be considered an action of discipline, but rather this action would be taken solely as a budget measure in order to ensure that in the event of a shortfall in business license revenue for the fiscal year 2016-2017 the financial condition of the city is not jeopardized. The period of lay-off and conversion would begin at such time as the plan is implemented by the City Manager and would last until further decision of the City Council. City Council, by this resolution, specifically reserves the right to make further decisions as to specific numbers of lay-offs and conversions as the need arises.

**Section 7:** In the event of a conflict between the provisions of this resolution and any other resolution, regulation, or policy of the City of San Luis, the conflicting provisions are hereby provisionally amended, superseded, and replaced, and the provisions of this resolution shall govern. In making this provision, it is the specific legislative intent of the City Council that the Personnel Policies of the City of San Luis, the Classification Plan of the City of San Luis, the 2006 Salary Plan of the City of City of San Luis, the salary administration regulations and policies of the City of San Luis are hereby amended, superseded and/or replaced by this resolution such that actions and plans authorized in this resolution shall govern and supersede any and all existing policies, regulations, or plans so that the action and plans authorized in this resolution may be implemented, and that this is a non-appealable final legislative decision and action of the City Council of the City of San Luis.

**Section 8:** If any section, subsection, sentence, clause, phrase, or portion of this resolution is for any reason held to be invalid or unconstitutional by the final decision of

any court of competent jurisdiction, such decision shall not affect the validity of the remaining portions of this resolution.

PASSED AND ADOPTED by the Mayor and Council of the City of San Luis, Arizona, this \_\_\_\_ day of \_\_\_\_\_, 2016.

\_\_\_\_\_  
Gerardo Sanchez, Mayor

ATTEST:

APPROVED AS TO FORM:

\_\_\_\_\_  
Sonia Cornelio, City Clerk

\_\_\_\_\_  
Kay Marion Macuil, City Attorney



## AGENDA ITEM REVIEW FORM

### Regular City Council Meeting

4. D.

Meeting Date: 06/08/2016

Department Head: Kay Macuil, City Attorney, Attorney's Office

Submitted By: Kay Macuil, City Attorney, Attorney's Office

Action Requested: Motion

#### ITEM:

Discussion and possible action on any and all matters regarding the matter of the appeal of APS vs. City of San Luis in the Arizona Tax Court Case Number TX 2014-000404. (Kay Marion Macuil, City Attorney)

#### SUMMARY:

City Council met in executive session on March 23, 2016 to be advised by the City Attorney and the litigation attorney Andrew Federhar of Fennemore and Craig regarding the litigation involving APS's unpaid taxes to the City of San Luis. Council gave instruction to the City Attorney as is permitted under the Open Meeting Law A.R.S. §38-431.03(A)(3). (The Agenda from March 23, 2016 is attached).

An Arizona Court Case has ruled that a decision to appeal must be made in open session in order for an appeal in a court case to be authorized by the governing body. (The case is attached, Johnson v. Tempe Elementary School Dist. No. 3 Governing Bd.)

The last matter to be decided in the lower court issued on June 3, 2016 and Mr. Federhar is ready to appeal. Because this item was discussed on March 23, 2016, this item is on the consent agenda for a decision in open meeting for appeal.

#### RECOMMENDATION / SUGGESTED MOTION:

**I MOVE TO AUTHORIZE AND DIRECT THE PROSECUTION OF AN APPEAL FROM THE JUDGMENT AGAINST THE CITY OF SAN LUIS IN CASE NO. TX 2014-000404 SUPERIOR COURT OF THE STATE OF ARIZONA IN THE ARIZONA TAX COURT, TO DEFEND AGAINST ANY APPEAL FROM JUDGMENTS OR DECISIONS IN FAVOR OF THE CITY, AND TO ENGAGE FENNEMORE CRAIG LAW FIRM TO DO SO PURSUANT TO THE AGREEMENT PREVIOUSLY MADE.**

#### Supporting information not attached to the Agenda Item Review Form:

All supporting information is attached to this Agenda Item Review Form

Document to be Recorded?: No

N/A

#### Fiscal Impact

IS THERE FISCAL IMPACT ASSOCIATED WITH THIS ITEM:	Yes
CITY/STATE/FEDERAL FUNDS:	City
TOTAL:	N/A

**BUDGETED:**

NO

**AVAILABLE TO TRANSFER:**

Yes

**GL ACCT # & NAME/REMAINING BALANCE BEFORE PURCHASE:** Contingencies

**FISCAL IMPACT STATEMENT (IF THIS IS A BUDGET TRANSFER, YOU MUST ATTACH THE BUDGET ADJUSTMENT FORM):**

Possible fiscal impacts were discussed.

---

**Attachments**

March 23 Agenda

Open Meeting Case

---



## **NOTICE OF REGULAR COUNCIL MEETING**

In accordance with Section 38-431.01 of the Arizona Revised Statutes of the State of Arizona, notice is hereby given to the Members of City Council and to the general public that the Mayor and Council of the City of San Luis, Arizona will hold a Regular City Council meeting at 7:00 p.m. Wednesday, March 23, 2016. The meeting will take place at the City Council Chambers, located at 1090 E. Union Street, San Luis, Arizona, 85349. Everyone from the public is invited to attend the open meeting.

In accordance with the Americans with Disabilities Act (ADA) and Section 504 of the Rehabilitation Act of 1973, the City of San Luis does not discriminate on the basis of disability in the admission of or access to, or treatment of employment in its programs, activities, or services. For information regarding rights and provisions of the ADA or Section 504, or to request reasonable accommodations for participation in City programs, activities or services contact: ADA/Section 504 Coordinator, City of San Luis Human Resources Department, 1090 E. Union Street, San Luis, Arizona, 85349, (928) 341-8520.

Notice is hereby given that pursuant to A.R.S. §1-602.A.9, subject to certain specified statutory exceptions, parents have a right to consent before the State or any of its political subdivisions make a video or audio recording of a minor child. Meetings of the City Council are audio and/or video recorded, and, as a result, proceedings in which children are present may be subject to such recordings. Parents in order to exercise their rights may either file written consent with the City Clerk to such recordings, or take personal action to ensure that their child or children are not present when a recording may be made. If a child is present at the time a recording is made, the City will assume that the rights afforded parents pursuant to A.R.S. §1-602.A.9 have been waived.

### **THIS NOTICE IS APPROVED BY:**

/s/ Sonia Cornelio, City Clerk

## **AVISO DE JUNTA REGULAR**

De acuerdo a la Sección 38-431.01 de los Estatutos Revisados del Estado de Arizona, se le informa a los Miembros del Cabildo y al público en general que el Alcalde y el Concilio de San Luis, Arizona, tendrán una Junta Regular a las 7:00 p.m. el día Miércoles, 23 de Marzo del 2016. La junta se llevará a cabo en la Sala del Cabildo, ubicada en el 1090 E. Union Street, San Luis, Arizona, 85349, el público está cordialmente invitado.

De acuerdo con el Acta de Americanos con Discapacidades y la Sección 504 del Acta de Rehabilitación del 1973, la Ciudad de San Luis no discrimina por causa de discapacidad la admisión y acceso a sus programas, actividades, servicios o en el trato en cuanto a empleo. Para más información referente a derechos y provisiones del Acta de Americanos con Discapacidades o Sección 504, o para solicitar adaptaciones que sean razonables para la participación en programas, actividades o servicios de la Ciudad, contactar al: Coordinador del Acta de Americanos con Discapacidades/Sección 504, Departamento de Recursos Humanos de la Ciudad de San Luis, 1090 E. Union Street, San Luis, Arizona, 85349, (928) 341-8520.

Por medio de este aviso y de acuerdo con los Estatutos Revisados del Estado de Arizona, sujeto a ciertas excepciones reglamentarias, los padres de familia tienen el derecho de dar o no dar el consentimiento antes que el Estado o alguna subdivisión política grabe a un menor de edad, ya sea en audio o video. Las juntas del Cabildo se graban en audio y/o video y como resultado, el hecho de que haya menores presentes puede ser sujeto a que sean grabados. Para que los padres de familia puedan ejercer sus derechos, favor de autorizar por escrito con la Secretaria de la Ciudad a tal grabación, o tomar acción personal para asegurarse que su hijo/hija menor no esté presente cuando la grabación se lleve a cabo. Si un menor de edad está presente en el momento de la grabación, la Ciudad asumirá que los padres de familia están cediendo los derechos sobre una posible grabación de acuerdo con el Estatuto Revisado del Estado de Arizona §1-602.A.9.

### **ESTE AVISO ES APROBADO POR:**

/f/ Sonia Cornelio, Actuaría de la Ciudad



**AGENDA**  
**Regular Meeting**  
**San Luis City Council**  
**San Luis Council**  
**Chambers**  
**1090 E. Union Street**  
**San Luis, AZ 85349**  
**March 23, 2016**  
**7:00 P.M.**

**MEMBERS OF THE CITY COUNCIL WILL ATTEND EITHER IN PERSON, TELEPHONE, OR VIDEO CONFERENCE COMMUNICATION**

1. **CALL TO ORDER/ROLL CALL**
2. **PLEDGE OF ALLEGIANCE**
3. **INVOCATION**
4. **OATH OF OFFICE & SWEARING-IN CEREMONY OF**  
- Chief of Police Craig Higgins
5. **CONSENT AGENDA**  
All matters are considered to be routine by the City Council and will be enacted by one motion. If discussion is desired, that item will be removed from the Consent Agenda and will be considered separately.
5. **A. MINUTES OF**  
-Regular Council meeting held February 10, 2016  
-Work Session held February 17, 2016
5. **B. DISBURSEMENTS FROM FEBRUARY 29, 2016 THROUGH MARCH 11, 2016**  
Total Disbursements \$524,542.74  
(Five-Hundred Twenty-Four Thousand, Five-Hundred Forty-Two Dollars and Seventy-Four Cents)
6. **DISCUSSION AND POSSIBLE ACTION ITEMS:**
6. **A.** Discussion and possible action on any and all matters regarding the location of the 2016 Employee Annual Picnic at Waylon's Water Park, purchase of food, use of amenities and waiver of purchasing procedures as permitted under San Luis City Code Section 36.01(H). **(Maria Sabori, Human Resources Senior Analyst)**
6. **B.** Discussion and possible action on any and all matters regarding the purchase of artificial turf for the conversion of the old Joe Orduño tennis court to a futsal soccer field. **(Chris Kasid, Parks and Recreation Director)**

6. C. Discussion and possible action on any and all matters regarding acceptance of proposal for audit services and approval of contract to the highest-scoring proposal by Heinfeld, Meech & Co., PC. **(Katie St. Louis, Finance Director)**
6. D. Public Hearing followed by discussion and possible action on any and all matters regarding Resolution No. 1136. A resolution of the Mayor and City Council of the City of San Luis, Arizona, County of Yuma, authorizing the submission of an application for Fiscal Year 2015 State Community Development Block Grant State Special Projects Funds, certifying that said application meets the community's previously identified housing and community development needs and the requirements of the State Community Development Block Grant Program, and authorizing all actions necessary to implement and complete the activities outlined in said application. **(Jenny Torres, Community Development Director)**

**A. Open Public Hearing**

**B. Close Public hearing**

**C. Action on Resolution No. 1136**

6. E. Discussion and possible action on any and all matters regarding Resolution No. 1137. A resolution of the Mayor and City Council of the City of San Luis, Arizona, County of Yuma, committing local funds as leverage for a Fiscal Year 2015 Community Development Block Grant application. **(Jenny Torres, Community Development Director)**
6. F. Discussion and possible action on any and all matters regarding the Second Reading of Ordinance No. 348. An ordinance of the Mayor and City Council of the City of San Luis, Arizona, amending the San Luis Tax Code 2014 by adding Subsection 35-840 (d) relating to Sales Tax Rate for Retail Sales of Tangible Personal Property; establishing an effective date; and providing for severability. **(Kay M. Macuil, City Attorney)**

A. Approval of Second Reading of Ordinance No. 348 by title only.

B. Approval and Adoption of Ordinance No. 348.

**7. SUMMARY OF CURRENT EVENTS**

Events by Mayor, Council Members, City Manager, and/or City Staff pursuant to A.R.S. §38-431.02 (K).

**8. CALL TO THE PUBLIC**

This is the time for the public to comment. Members of the City Council may not discuss items that are not specifically identified on the agenda. Therefore, pursuant to A.R.S. §38-431.01 (H), action taken as a result of public comment will be limited to directing staff to study the matter, responding to any criticism or scheduling the matter for further consideration and decision at a later date.

**9. EXECUTIVE SESSION(S)**

Vote to hold and Executive Session(s) pursuant to A.R.S. §§38-431.03(A)(3) and 38-431.03(A)(4)

9. A. Discussion and possible action to hold an Executive Session pursuant to A.R.S. §§38-431.03(A)(3) and 38-431.03(A)(4) on any and all matters relating to the City's litigation with Arizona Public Service (APS) and related contracts for discussion or consultation for legal advice with the City Attorney or the City's Attorneys and in order to consider the City's position and instruct its Attorneys regarding the City's position. **(Kay Marion Macuil, City Attorney)**

9. B. Discussion and possible action to hold an Executive Session pursuant to A.R.S. §§38-431.03(A)(3) and 38-431.03(A)(4) for consultation for legal advice with the City Attorney and/or Attorneys for the City and to consider instructing the City Attorney on any all matters regarding the San Luis Regional Detention Center and related contracts that are subject of negotiations, in pending or contemplated litigation or in settlement discussions conducted in order to avoid or resolve litigation. **(Kay Marion Macuil, City Attorney)**
10. **MOTION TO GO BACK INTO REGULAR SESSION**
11. **ADJOURNMENT**

199 Ariz. 567  
Court of Appeals of Arizona,  
Division 1, Department B.

Keith JOHNSON, Plaintiff–Appellee,  
v.  
TEMPE ELEMENTARY SCHOOL DISTRICT NO.  
3 GOVERNING BOARD, Defendant–Appellant.

No. 1 CA–CV 99–0555.  
|  
Dec. 12, 2000.  
|  
As Amended March 22, 2001.

Teacher challenged his dismissal by school board. The Superior Court, Maricopa County, [Barry C. Schneider, J.](#), reversed the dismissal. Board appealed. The Court of Appeals, Gerber, J., held that: (1) school board violated open meeting law by making decision to appeal in executive session, and (2) appeal was null and void.

Affirmed.

West Headnotes (6)

<sup>[1]</sup> **Administrative Law and Procedure**  
🔑 Meetings in general

The enactment of open meeting law was an effort to ensure that the public could attend and monitor the meetings of all public bodies. [A.R.S. § 38–431 et seq.](#)

[2 Cases that cite this headnote](#)

<sup>[2]</sup> **Education**  
🔑 Meetings

School board violated open meeting law when, in executive session, it decided to appeal trial court’s ruling in an employment case, as decision to appeal was a “legal action,” in that it transcended discussion or consultation and entailed a commitment of public funds. [A.R.S. §](#)

[38–431.03, subd. D.](#)

[1 Cases that cite this headnote](#)

<sup>[3]</sup> **Administrative Law and Procedure**  
🔑 Meetings in general

Public bodies may not take final legal action in executive session. [A.R.S. § 38–431.03, subd. D.](#)

[Cases that cite this headnote](#)

<sup>[4]</sup> **Administrative Law and Procedure**  
🔑 Meetings in general

Exceptions to the open meeting law should be narrowly construed in favor of requiring public meetings. [A.R.S. § 38–431 et seq.](#)

[1 Cases that cite this headnote](#)

<sup>[5]</sup> **Administrative Law and Procedure**  
🔑 Meetings in general

Actions taken in violation of the open meeting law cease to exist or have any effect. [A.R.S. § 38–431.05, subd. A.](#)

[Cases that cite this headnote](#)

<sup>[6]</sup> **Administrative Law and Procedure**  
🔑 Meetings in general

Appeal resulting from legal action that violated the open meeting law, which was the decision to file the appeal, was null and void. [A.R.S. § 38–431.05, subd. A.](#)

[2 Cases that cite this headnote](#)

### Attorneys and Law Firms

**\*\*1148 \*567** Hobson & Ringler by [William R. Hobson](#) and Counters & Koelbel, P.C. by [Kevin Koelbel](#), Tempe, Attorneys for Plaintiff–Appellee.

The Cavanagh Law Firm by [Christopher Robbins](#) and Greenburg Traurig, L.L.C. by [James A. Ullman](#), [Michael Lungaretti](#), Phoenix, Attorneys for Defendant–Appellant.

Arizona School Boards Association by [Thomas W. Pickrell](#) and Miller LaSota & Peters, PLCP by [Donald M. Peters](#), [Susan A. Cannata](#), Phoenix, Attorneys for Amicus Curiae Arizona School Boards Association.

## OPINION

GERBER, Judge.

¶ 1 Appellant Tempe Elementary School District No.3 Governing Board (“the Board”) dismissed appellee Keith Johnson from his teaching position for a criminal conviction that occurred thirteen years before he was hired. Upon appeal by Johnson, the superior court reversed the dismissal. The Board then appealed to this court from that judgment. For the reasons discussed below, we find that the Board’s appeal is null and void.

### FACTS AND PROCEDURAL HISTORY

¶ 2 In 1994, after a 1982 incident involving a disturbing the peace conviction, Johnson filed an application to set aside the misdemeanor conviction. On March 28, 1995, the Phoenix Municipal Court entered an order vacating his judgment of guilt and dismissing the conviction.

**\*\*1149 \*568** ¶ 3 In September 1995, Johnson entered into a contract of employment with the Board for the 1995–96 school year. His application for certification was still pending before the State Board of Education. Johnson received a contract to teach in the District for the 1996–97 school year. On January 27, 1997, after investigating Johnson’s conviction, the Arizona Department of

Education issued him a teaching certificate. The District ordered a background check, which revealed the police report for the March 12, 1982, arrest. On April 2, 1997, the District Board voted not to renew Johnson’s contract. Johnson appealed the Board’s notice of non-renewal to the superior court, arguing that it did not comply with the relevant statute. The court ruled in Johnson’s favor.

¶ 4 The District issued a contract to Johnson for the 1997–98 school year, but the superintendent of the district assigned Johnson to his home. The superintendent issued a statement of charges (“SOC”) recommending Johnson’s dismissal; in October 1997, the Board adopted the SOC, which contained five charges. Johnson requested a public hearing to contest the SOC. At the conclusion of the hearing, the Board upheld the District’s decision to terminate him for unfitness (“charge B”) and misrepresentation (“charge E”).

¶ 5 When Johnson sought judicial review of the Board’s decision, the superior court ruled that the Board’s decisions on charges B and E “were founded on and contained errors of law, were unsupported by the entire record, and were arbitrary and capricious” and that the allegations of unfitness and misrepresentation lacked foundation. The superior court ordered that Johnson be reinstated as a teacher with back pay in the amount of \$34,183.60 and awarded him \$79,727.61 in attorneys’ fees and costs.

¶ 6 In June, 1999, after the superior court’s minute entry decision in favor of Johnson, the Board met in executive session with its attorney concerning the status of this litigation. The Board’s “Notice of Executive Session and Agenda” for this meeting read:

*Motion for executive session per A.R.S. § 38–431.03(A)(3) for discussion or consideration for legal advice with the attorney or attorneys of the public body and A.R.S. § 38–431.03(A)(4) for discussion or consultation with the attorneys of the public body in order to consider its position and instruct its attorneys regarding the public body’s position in pending or contemplated litigation regarding Keith Johnson.*

At this private meeting, the Board decided to appeal the superior court’s judgment. On September 24, 1999, the Board filed the present appeal from the superior court’s September 1 judgment.

### DISCUSSION

¶ 7 The Board raises multiple issues in its appeal. We address only the one dispositive issue. Johnson argues that a legal action decided by a public body in violation of open meeting statutes is null and void. *See* [Ariz.Rev.Stat. \(“A.R.S.”\) § 38–431.05\(A\)](#) (1996). For the reasons set forth below, we agree that the Board’s private decision to appeal violated the state’s open meeting law and that its notice of appeal is null and void.

<sup>[1]</sup> ¶ 8 The enactment of Arizona’s open meeting law “was an effort to ensure that the public could attend and monitor the meetings of all public bodies.” *Fisher v. Maricopa County Stadium Dist.*, 185 Ariz. 116, 122–23, 912 P.2d 1345, 1351–52 (App.1995) (citing A.R.S. §§ 38–431 to 431.09 (1996)). Under section 38–431.01(A), “[a]ll meetings of any public body shall be public meetings and all persons so desiring shall be permitted to attend and listen to the deliberations and proceedings.”

¶ 9 Although the intent of the open meeting act is that official deliberations and proceedings of public governing bodies be conducted openly, “[t]he public’s right to know and to participate in the decision-making process frequently comes into sharp conflict with the need for confidentiality in certain areas.” *Hokanson v. High Sch. Dist. No. Eight of Pima County*, 121 Ariz. 264, 267, 589 P.2d 907, 910 (App.1978). The legislature accordingly has crafted narrow exceptions to the open meeting requirements. The circumstances under which a public body may meet in an executive session appear in relevant part in [section 38–431.03\(A\)](#):

**\*\*1150 \*569** A. [A] public body may hold an executive session but only for the following purposes:

\* \* \*

3. Discussion or consultation for legal advice with the attorney or attorneys of the public body.

4. Discussion or consultation with the attorneys of the public body in order to consider its position and instruct its attorneys regarding the public body’s position in pending or contemplated litigation.

However, “[n]o executive session may be held for the purpose of taking any legal action involving a final vote or decision.” [A.R.S. § 38–431.03\(D\)](#).

<sup>[2]</sup> ¶ 10 The Board purported to meet in executive session under [section 38–431.03\(A\)\(3\)–\(4\)](#) to decide to appeal the superior court’s judgment. On appeal, the Board now argues that it complied with Arizona’s open meeting statute because [section 38–431.03\(A\)\(3\)–\(4\)](#) allows a public body, meeting in an executive session, to instruct its

attorneys to file an appeal. We disagree because we find the scope of these statutes to be much more limited.

<sup>[3]</sup> ¶ 11 We must first decide whether the decision to appeal the superior court’s judgment constituted only discussion or consultation with its attorneys for legal advice or to give instructions regarding pending litigation under [section 38–431.03\(A\)\(3\)–\(4\)](#) or legal action under [section 38–431.03\(D\)](#). “Legal action” is defined as “a collective decision, commitment or promise made by a majority of the members of a public body pursuant to the constitution, their charter or bylaws or specified scope of appointment or authority, and the laws of this state.” [A.R.S. § 38–431\(2\)](#). Public bodies may not take final legal action in executive session. [A.R.S. § 38–431.03\(D\)](#); *Cooper v. Arizona Western Coll. Dist. Governing Bd.*, 125 Ariz. 463, 466, 610 P.2d 465, 468 (App.1980).

¶ 12 The Arizona Supreme Court in *City of Prescott v. Town of Chino Valley*, 166 Ariz. 480, 485, 803 P.2d 891, 896 (1990), and this court in *Fisher*, 185 Ariz. at 124, 912 P.2d at 1353, considered the scope of “legal advice.” In those cases, the courts interpreted “legal advice” under [section 38–431.03\(A\)\(3\)](#) to include advice concerning potential legislation (*Prescott*) and negotiation of an agreement mixing taxpayer funds and private enterprise monies (*Fisher*). *Prescott*, 166 Ariz. at 484, 803 P.2d at 895; *Fisher*, 185 Ariz. at 124, 912 P.2d at 1353. However, those courts stated that “ ‘once the members of the public body commence any discussion regarding the merits of enacting the legislation or *what action to take based upon the attorneys’ advice*, the discussion moves beyond the realm of legal advice and *must be open to the public.*’ ” *Fisher*, 185 Ariz. at 124, 912 P.2d at 1353 (quoting *Prescott*, 166 Ariz. at 485, 803 P.2d at 896) (emphasis added).

¶ 13 Courts in other states have addressed whether deciding to appeal constitutes legal action. In *Houman v. Mayor & Council of the Borough of Pompton Lakes*, 155 N.J.Super. 129, 382 A.2d 413, 425–28 (1977), the New Jersey Superior Court held that the council could discuss in an executive session whether to appeal to the State Tax Court but that the council violated the New Jersey Open Public Meetings Act when it took formal action to do so in executive session. Similar to [section 38–431.03\(A\)\(4\)](#), New Jersey law permits executive sessions only to “discuss” pending or anticipated litigation. *Id.* at 421. That court reasoned that “discuss” does not include final decisions, and hence a decision to appeal is not a “discussion” but rather a final decision that must be made in public. *Id.* at 428. *Cf. City of Danville v. Laird*, 223 Va. 271, 288 S.E.2d 429, 431 (1982) (holding that council discussion in executive session of whether to appeal did

not violate the open meeting law given that ultimate decision to adopt ordinance to meet the objections of trial court was made in public).

<sup>[4]</sup> ¶ 14 The Arizona open meeting law compels a finding similar to that in *Houman*. Exceptions to the open meeting law “should be narrowly construed in favor of requiring public meetings.” *Fisher*, 185 Ariz. at 123, 912 P.2d at 1352. Our legislature has declared that “any person or entity charged with the interpretations of this article shall take into account the policy of this article and shall construe any provision of this article in favor of open and public meetings.” \*\*1151 \*570 A.R.S. § 38–431.09 (1996); see also *Prescott*, 166 Ariz. at 483, 803 P.2d at 894 (quoting A.R.S. § 38–431.09); *Fisher*, 185 Ariz. at 123, 912 P.2d at 1352 (same).

¶ 15 With this directive in mind, and given the fact that the open meeting issue was promptly raised in the appellate court when, arguably, there may have been time to correct the violation, we cannot extend the “legal advice” and “pending litigation” exceptions to include a final decision to appeal. Section 431.03(A)(3)-(4) limits executive sessions to “discussion or consultation,” in contrast to the “collective decision” or “commitment” that comprises “legal action.” § 38–431(2). While A.R.S. section 38–431.03(A)(3)(4) permits board members privately to discuss or consult with their attorneys concerning legal advice or pending litigation, section 38–431.03(C) prohibits holding such executive sessions for taking any legal action involving a final vote or decision. A decision to appeal transcends “discussion or consultation” and entails a “commitment” of public funds. Therefore, once the Board finished privately discussing the merits of appealing, the open meeting statutes required that board members meet in public for the final decision to appeal.

¶ 16 The Board argues that announcing its decision to appeal in an open meeting might deter settlement and reinstatement. Aside from such speculation, the law

recognizes no such exception. Under the statute, any discussions concerning strategy and the merits of the case could be conducted in executive session, but the final vote or decision to appeal needed to be public.

<sup>[5]</sup> <sup>[6]</sup> ¶ 17 We conclude that the Board violated the open meeting law when, in executive session, it decided to appeal the superior court’s judgment. When a public body takes legal action that violates the open meeting law without timely ratification, that legal action is “null and void.” A.R.S. § 38–431.05(A). Actions taken in violation of the open meeting law “cease to exist or have any effect.” *Van Alstyne v. Hous. Auth. of Pueblo, Colo.*, 985 P.2d 97, 101 (Colo.Ct.App.1999). Here, the legal action violating the open meeting law was the very decision to file this appeal. Accordingly, this resulting appeal is null and void. See *Berry v. Bd. of Governors of Reg. Dentists*, 611 P.2d 628, 632 (Okla.1980) (reversing granting of injunction because board failed to vote to seek injunctive relief in a public meeting).<sup>1</sup>

¶ 18 Johnson requests an award of his attorneys’ fees incurred in this appeal under A.R.S. section 12–341.01 (Supp.1999). In our discretion, we grant this request and award him his costs and fees incurred in this appeal upon compliance with Rule 21, Arizona Rules of Civil Appellate Procedure.

CONCURRING: PHILIP E. TOCI, Presiding Judge, E.G. NOYES, JR., Judge.

#### All Citations

199 Ariz. 567, 20 P.3d 1148, 153 Ed. Law Rep. 380, 343 Ariz. Adv. Rep. 25

#### Footnotes

<sup>1</sup> The anomaly of addressing a “null and void” appeal even in part does not escape us. However, given both our mandate to explain our decisions and the novelty and importance of the factual parameters of the open meeting law, we think that we must explain the reasons for finding this appeal to be invalid.





## AGENDA ITEM REVIEW FORM

### Regular City Council Meeting

5. A.

**Meeting Date:** 06/08/2016

**Department Head:** Kay Macuil, City Attorney, Attorney's Office

**Submitted By:** Kay Macuil, City Attorney, Attorney's Office

Action Requested:

---

#### ITEM:

Discussion and possible action on any and all matters regarding ratifying a contract for a Judge Pro Tempore / Administrative Manager for the San Luis Municipal Court. **(Kay Marion Macuil, City Attorney and Tadeo A. De La Hoya, Interim Manager)**

#### SUMMARY:

The Presiding Judge for the Superior Court for Yuma County has supervisory powers over the municipal courts in Yuma County. In March of this year and in consultation with City staff, the Presiding Judge appointed Justice of the Peace Juan M. Guerrero to fill the vacancy of the Magistrate created by the retirement of Rosendo Morales while the City recruited for a permanent replacement.

After working with the San Luis Municipal Court, Presiding Judge Maria Elena Cruz issued an Administrative Order on May 23, 2016 appointing Cora Romine as Judge Pro Tempore / Administrative Manager replacing the Justice of the Peace for coverage of the San Luis Magistrate. Cora Romine was a Justice of the Peace for Wellton and before that worked many years as a Clerk in Yuma.

The functions of the Judge Pro Tempore / Administrative Manager include maintaining oversight and control of all of the San Luis Municipal Court records used to conduct court business as well as coverage of the duties of Magistrate. The full Administrative Order and Contract are attached.

Cora Romine began work on June 1, 2016 and will be paid under the regular billing cycle June 16, 2016. As is the case with all Judge Pro Tempore, the travel costs are to be covered. So a City vehicle and fuel costs for commuting from Wellton for work will be provided by the City.

As of the date of publication of this Agenda, the City's recruitment process for Magistrate was complete and an offer had been extended for recommendation to City Council.

Staff recommends ratifying the contract for Judge Pro Tempore / Administrative Manager with Cora Romine.

#### RECOMMENDATION / SUGGESTED MOTION:

**I MOVE TO APPROVE AND RATIFY THE CONTRACT WITH CORA ROMINE FOR JUDGE PRO TEMPORE / ADMINISTRATIVE MANAGER AS PRESENTED.**

Supporting information not  
attached to the Agenda Item  
Review Form:

Supporting information is attached to this Agenda Item Review Form

**Document to be Recorded?:**

---

**Fiscal Impact**

**IS THERE FISCAL IMPACT ASSOCIATED WITH THIS ITEM:** Yes  
**CITY/STATE/FEDERAL FUNDS:** City  
**TOTAL:** 6,440.00  
**BUDGETED:** Yes  
**AVAILABLE TO TRANSFER:** \$13,390.00  
**GL ACCT # & NAME/REMAINING BALANCE BEFORE PURCHASE:** 100-160-80000  
**FISCAL IMPACT STATEMENT (IF THIS IS A BUDGET TRANSFER, YOU MUST ATTACH THE BUDGET ADJUSTMENT FORM):**

This is a temporary position for an undetermined time for \$35 per hour plus a city-provided vehicle and fuel to commute for work from Wellton to the San Luis Municipal Court.

---

**Attachments**

Pro Tem Admin Contract  
Admin Order 2016-20

---

**CITY OF SAN LUIS, ARIZONA  
CONTRACT  
JUDGE PRO TEMPORE/ADMINISTRATIVE MANAGER  
FOR  
SAN LUIS MUNICIPAL COURT**

THIS CONTRACT is made and entered into this \_\_\_\_day of \_\_\_\_\_, 2016, and is effective the 23<sup>rd</sup> day of May, 2016, by and between the CITY OF SAN LUIS, ARIZONA, a municipal corporation (hereinafter referred to as the "City") and Cora Romine, hereinafter referred to as ("Judge Pro Tempore/Administrative Manager"), both of whom understand as follows:

WHEREAS, the Presiding Judge of the Yuma County Superior Court has appointed Judge Pro Tempore/Administrative Manager to serve as the Judge Pro Tempore/Administrative Manager for the City of San Luis by the Administrative Order 2016-20 issued by the Superior Court for Yuma County dated May 23, 2016 under its authority granted the Administrative Order 2016-25 issued by Arizona Chief Justice Scott Bales on March 30, 2016, A.R.S. §22-121, and the Code of Judicial Administration §1-305(E);

WHEREAS, the City desires only to engage the services of Judge Pro Tempore/ Administrative Manager on a temporary, full-time basis;

WHEREAS, it is the desire of the City Council to secure and retain the services of Judge Pro Tempore/Administrative Manager, while providing a means for terminating Judge Pro Tempore/Administrative Manager's services at such time as Judge Pro Tempore/Administrative Manager may be unable to fully discharge Judge Pro Tempore/Administrative Manager's duties or when the City may desire to otherwise terminate Judge Pro Tempore/Administrative Manager's assignment in accordance with the law.

NOW, THEREFORE, in consideration of the mutual covenants herein contained, the parties hereto agree as follows:

**Section 1. Duties**

City hereby agrees to accept the appointment of Cora Romine as City Judge Pro Tempore/Administrative Manager of the City on a temporary basis to perform the functions and duties as permitted by Arizona law as acting as a Judge Pro Tempore as needed and functioning as administrative manager of San Luis Municipal Court. The functions of the administrative manager will be to maintain oversight and control of all San Luis Municipal Court records. Court records include paper records, electronic

records, case and financial records and cash, checks, money order, receipt books, check books and other records used to conduct court business.

## **Section 2. Term**

A. Nothing in this Contract shall prevent, limit or otherwise interfere with the right of the City Council to terminate the services of Judge Pro Tempore/Administrative Manager as provided by law.

B. Nothing in this contract shall prevent, limit or otherwise interfere with the right of Judge Pro Tempore/Administrative Manager to resign at any time from this temporary appointment as City Judge Pro Tempore/Administrative Manager of the City, subject only to the provisions set forth in Section 3 of this Contract.

C. The parties agree that this appointment is temporary, for which no set term is attached, and for which no severance or separation pay shall be paid at the termination of the assignment. It is anticipated that Judge Pro Tempore/Administrative Manager will serve as the City Judge Pro Tempore/Administrative Manager until such time as the Presiding Superior Court Judge for Yuma County makes a further administrative order terminating this appointment.

## **Section 3. Termination**

In the event Judge Pro Tempore/Administrative Manager voluntarily terminates this assignment with the City, the Presiding Judge of the Superior Court ends the appointment, or the City determines to end the temporary assignment, the parties agree to give two weeks' notice in advance, or such advance notice as may otherwise be mutually agreed upon. No severance or separation pay shall be paid at the termination of the assignment.

## **Section 4. Compensation**

City agrees to make bi-weekly (every two weeks) payments at the rate of \$35.00 per hour to Judge Pro Tempore/Administrative Manager Cora Romine in accordance with the City's usual payment and billing cycle.

## **Section 5. Hours of Work**

Judge Pro Tempore/Administrative Manager shall work during such hours as are necessary to properly operate and maintain the San Luis Municipal Court.

## **Section 6. Other Terms and Conditions of Assignment**

- A. The City shall provide a vehicle and fuel associated with Judge Pro Tempore/Administrative Manager Cora Romine's round-trip work-related commute from Wellton, Arizona to San Luis, Arizona.

- B. City Council shall fix any such other terms and conditions of Judge Pro Tempore/Administrative Manager's appointment as it may determine from time to time, relating to the performance of Judge Pro Tempore/Administrative Manager, provided that such terms and conditions are not inconsistent with or in conflict with provisions of this Contract, the Administrative Order 2016-20 issued by the Superior Court for Yuma County dated May 23, 2016, the City Code, State Law or Arizona Supreme Court Rules or Regulations.
  
- C. This Contract is contingent upon Judge Pro Tempore/Administrative Manager's continued acceptability by the Arizona Supreme Court and any other regulatory body which governs municipal courts in the state of Arizona. In the event Judge Pro Tempore/Administrative Manager is unacceptable at any time for any reason(s) by the Arizona Supreme Court, this contract is null and void. Judge Pro Tempore/Administrative Manager agrees to advise the Mayor or City Manager immediately should Judge Pro Tempore/Administrative Manager receive any judicial conduct complaint or should Judge Pro Tempore/Administrative Manager become aware of any other matter that could result in not being able to fulfill his duties as the City Judge Pro Tempore/Administrative Manager.

**Section 7. General Provisions**

- A. The text herein shall constitute the entire agreement between the parties.
  
- B. This Contract is effective the 23rd day of May, 2016. If any provisions or any portion thereof contained in this Contract are held to be unconstitutional, invalid or unenforceable, the remainder of this Contract shall be deemed severable, shall not be affected and shall remain in full force and effect.

\_\_\_\_\_  
 Cora Romine, Judge Pro Tempore/Administrative Manager

CITY OF SAN LUIS

\_\_\_\_\_  
 Gerardo Sanchez, Mayor

ATTEST:

APPROVED AS TO FORM:

\_\_\_\_\_  
 Sonia Cornelio  
 City Clerk

\_\_\_\_\_  
 Kay Marion Macuil  
 City Attorney

Copy: Presiding Superior Court Judge Maria Elena Cruz

FILED

2016 MAY 23 PM 4:00

LYNN FAZZ  
CLERK OF SUPERIOR COURT  
YUMA, ARIZONA 85364

**IN THE SUPERIOR COURT OF THE STATE OF ARIZONA**

**IN AND FOR THE COUNTY OF YUMA**

In the Matter of:	)	
	)	Administrative Order
APPOINTMENT OF CORA ROMINE	)	2016-20
AS JUDGE PRO TEMPORE/	)	
ADMINISTRATIVE MANAGER	)	
FOR SAN LUIS MUNICIPAL COURT IN	)	
YUMA COUNTY FOR THE BENEFIT	)	
OF THE COURTS OF THE COUNTY	)	
OF YUMA, STATE OF ARIZONA	)	
_____	)	

Pursuant to Supreme Court Administrative Order 2016-25 issued by Arizona Chief Justice Scott Bales on March 30, 2016, the administrative control and oversight of day-to-day operations of the San Luis Municipal Court and authority to assign judges as needed to conduct court business was granted to the Honorable Maria Elena Cruz, Presiding Judge, Superior Court in Yuma County.

Further, pursuant to Arizona Revised Statutes, §22-121 and the Code of Judicial Administration §1-305 E, the Presiding Judge may appoint judges pro tempore on a temporary full-time basis.

**IT IS THEREFORE ORDERED** that Cora Romine is appointed as Judge Pro Tempore/Administrative Manager for the San Luis Municipal Court effective May 23, 2016, until further orders from this court. The duties of the Judge Pro Tempore/Administrative Manager include, but are not limited to, acting as a Judge Pro Tempore as needed and functioning as administrative manager of San Luis Municipal Court. For purposes of this order, the functions of the administrative manager will be to maintain oversight and control of all San Luis Municipal Court records. Court records include paper records, electronic records, case and financial records and cash, checks, money orders, receipt books, check books and other records used to conduct court business.

1           **IT IS FURTHER ORDERED** that Cora Romine shall receive compensation at the  
2 rate of \$35.00/hour; a vehicle provided by the City of San Luis, and reimbursement for fuel  
3 costs associated with her round-trip daily commute from Wellton, Arizona to San Luis,  
4 Arizona. Any and all compensation and expenses incurred shall be paid directly to Ms.  
5 Romine by the City of San Luis, Arizona.

6           **IT IS FURTHER ORDERED** that the instant order supersedes Yuma County  
7 Superior Court Administrative Order 2016-11.

8           **DATED** this 23<sup>rd</sup> day of May, 2016.

9   
10 \_\_\_\_\_  
11 Honorable Maria Elena Cruz  
12 Presiding Judge

13 **Copies to:**

14 Hon. Maria Elena Cruz, Presiding Judge  
15 Hon. David M. Haws, Associate Presiding Judge  
16 Hon. Mark Wayne Reeves, Juvenile Presiding Judge  
17 Hon. John Paul Plante, Div. 2  
18 Hon. Larry Kenworthy, Div. 3  
19 Hon. Kathryn Stocking-Tate, Comm. 1  
20 Hon. Stephen J. Rouff, Comm. 2  
21 Hon. Gregory S. Stewart, Justice Courts Presiding Judge  
22 Hon. Yolanda V. Torok, JP1  
23 Hon. Juan M. Guerrero, JP2  
24 Hon. Russ Jones, JP3  
25 Hon. James F. Coil, City of Yuma Presiding Judge  
26 Hon. Jeanette Umphress, Magistrate  
27 Hon. Manuel Figueroa, Somerton Magistrate  
28 Hon. Lynn Fazz, Clerk of the Superior Court  
Margaret C. Guidero, Court Administrator  
Kathleen M. Schaben, Trial Court Administrator  
Sandi Hoppough, Chief Adult Probation Officer  
Tim Hardy, Director of Juvenile Court Services  
Cary W. Meister, Court IT Manager  
Dona Miller-Robbins, Caseflow Manager  
Susan K. Thorpe, County Administrator  
Jon R. Smith, Yuma County Attorney  
Michael Breeze, Yuma County Public Defender  
Terri L. Capozzi, Yuma County Legal Defender  
Shannon Gunderman, Conflict Administrator  
Jerry Sanchez, Mayor of San Luis  
Tadeo de la Hoya, Interim San Luis City Administrator  
Kay Macuil, San Luis City Attorney  
Jose de la Vara, San Luis City Prosecutor  
Andrea Ruiz, San Luis Municipal Court Administrator  
Yuma County Bar Association



## AGENDA ITEM REVIEW FORM

### Regular City Council Meeting

5. B.

**Meeting Date:** 06/08/2016

**Department Head:** Eulogio Vera, Public Works Director, Public Works Department

**Submitted By:** Manuel Rojas, Assistant Public Works Director, Public Works Department

**Action Requested:** Motion

---

### ITEM:

Discussion and possible action on any and all matters pertaining to the approval to award the 300 thousand gallons, tank (Well Site #3) & 500 thousand gallons, tank (Well Site #4) Maintenance/Rehabilitation Project contract to Revolution Industrial. **(Manuel Rojas, Assistant Public Works Director)**

### SUMMARY:

Following the Inspection report by Marine Diving Solutions of Well Site #3 and Well Site #4 water storage tanks, staff recommended the rehabilitation of subject storage tanks. Rehabilitation consists of sand blasting, primer application and a new coat of paint application on the inside of the tank. After an in depth inspection after sand blasting procedure, epoxy or structural repairs to the infrastructure may be determined if necessary. Maintenance of storage tank and repairs as needed will increase infrastructure life and minimize future costly repairs.

### RECOMMENDATION / SUGGESTED MOTION:

**I MOVE TO ACCEPT THE BID AND APPROVE THE CONTRACT WITH REVOLUTION INDUSTRIAL FOR AN AMOUNT NOT TO EXCEED \$215,000.00.**

**Supporting information not attached to the Agenda Item Review Form:**

N/A

**Document to be Recorded?:** No

N/A

---

### Fiscal Impact

<b>IS THERE FISCAL IMPACT ASSOCIATED WITH THIS ITEM:</b>	Yes
<b>CITY/STATE/FEDERAL FUNDS:</b>	Enterprise Funds
<b>TOTAL:</b>	\$215,000.00
<b>BUDGETED:</b>	\$213,480.00
<b>AVAILABLE TO TRANSFER:</b>	\$1,600.00
<b>GL ACCT # &amp; NAME/REMAINING BALANCE BEFORE PURCHASE:</b>	300-302-90000.806 Capital Outlay - Equipment Impact Fees
<b>FISCAL IMPACT STATEMENT (IF THIS IS A BUDGET TRANSFER, YOU MUST ATTACH THE BUDGET ADJUSTMENT FORM):</b>	

Water Rehab Project, \$215,680 was approved as part of the CIP, FY2016, 300-302-90000.806 Capital Outlay - Equipment Impact Fees. If any additional funds are required, we will be transferring funds from 300-302-70025 Maintenance/Other, \$1,600.00.

---

**Attachments**

Bid Proposals

Bid Tabulation

---

**CITY OF SAN LUIS  
REQUEST FOR PROPOSALS  
No. PW-2016-01**

**300 K Gal. Tank (Well Site # 3) & 500 K Gal. Tank (Well Site # 4) Rehabilitation**

**CONTRACT**

**CITY OF SAN LUIS**

**MAINTANCE/REHABILITATION CONTRACT**

**AGREEMENT:**

On June 2, 2016 the City of San Luis City Council ("CITY") authorized the award of a maintenance/rehabilitation contract for the City of San Luis 300 K Gal. Tank (Well Site # 3) & 500 K Gal. Tank (Well Site # 4) Revolution Industrial ("CONTRACTOR") doing business as a corporation located in the 6633 W. Willis Rd. Box 5052 Chandler, AZ 85226.

For the consideration of the payments and agreements in this contract, to be made and performed by the CITY, the CONTRACTOR agrees with the CITY to commence and complete the project as follows:

**Article 1: Contract Documents**

The Contract Documents consist of the CITY-CONTRACTOR Agreement, the Conditions of the Contract (General, Supplemental and other Conditions), the Project Specifications, all Addenda issued prior to and all modifications issued after execution of the Contract, and all applicable laws, ordinances and regulations. A modification is (1) a written amendment to the contract signed by both parties, (2) a Change Order, (3) a written interpretation issued by the CITY or (4) a written order for a minor change in the WORK issued by the CITY. The Contract Documents include Bidding Documents such as the Instructions to Bidders, sample forms, the CONTRACTOR's Bid or portions of addenda relating to any of these, or any other documents, specifically enumerated in the CITY-CONTRACTOR Agreement.

The Contract Documents form the Contract for Construction. This Contract represents the entire and integrated agreement between the parties and supersedes all prior negotiations, representations, or Agreements, either written or oral. The Contract may be amended or modified.

In interpreting the Contract, in the event of discrepancies or conflicts:

- 1) the Special Conditions govern over Specifications

**CITY OF SAN LUIS  
REQUEST FOR PROPOSALS  
No. PW-2016-01**

**300 K Gal. Tank (Well Site # 3) & 500 K Gal. Tank (Well Site # 4) Rehabilitation**

**Article 2: The WORK**

The CONTRACTOR will perform all the WORK required under this agreement as described below:

**CITY OF SAN LUIS 300 K GAL. TANK (WELL SITE # 3) & 500 K GAL. TANK  
(WELL SITE # 4) MAINTENANCE/REHABILITATION PROJECT**

Vianey R. Vega, P.E. from Vega & Vega Engineering, PLC. "City Engineer" will be the administrator of this Contract, and is the interpreter of the Contract Documents and the judge of the CONTRACTOR's performance of the WORK. All reference to the "City Engineer" or "Engineer" in these documents includes the City Engineer, and authorized representatives.

**Article 3: Time of Commencement and Completion**

CONTRACTOR must begin work within 3 calendar days of the date established by the Notice to Proceed and, subject to modifications authorized by the City Engineer, and complete WORK by June 29<sup>th</sup> 2016 as specified in Request for Proposal.

**Article 4: Contract Sum**

The CITY will pay the CONTRACTOR for performance of the WORK, subject to additions and deletions by Change Order, the sum of: One hundred twenty thousand, two hundred twelve dollars and eighty six cents.

**Article 5: Progress Payments**

The CONTRACTOR must apply to the City Engineer for progress payments. The CITY will make progress payments pursuant to A.R.S. §34-221 and with the City Engineer's approval of CONTRACTOR's application. Progress payments are subject to retainage amounts as deemed necessary by the City Engineer for incomplete WORK, unsettled claims, and other deficiencies.

**CITY OF SAN LUIS  
REQUEST FOR PROPOSALS  
No. PW-2016-01**

**300 K Gal. Tank (Well Site # 3) & 500 K Gal. Tank (Well Site # 4) Rehabilitation**

This Contract is effective on the \_\_\_\_\_ day of \_\_\_\_\_, 2016.

**CONTRACTOR**

by \_\_\_\_\_

Print Name: \_\_\_\_\_

Title \_\_\_\_\_

Date \_\_\_\_\_

**CITY OF SAN LUIS**

by \_\_\_\_\_

Tadeo A. De La Hoya, Interim CITY MANAGER

**ATTEST:**

\_\_\_\_\_

Sonia Cuello, CITY CLERK

\_\_\_\_\_

Date Signed

**APPROVED AS TO FORM:**

\_\_\_\_\_

Kay Marion Macuil, CITY ATTORNEY



**CITY OF SAN LUIS  
REQUEST FOR PROPOSALS  
No. PW-2016-01**

**300 K Gal. Tank (Well Site # 3) & 500 K Gal. Tank (Well Site # 4) Rehabilitation**

OPENING DATE: 3:00 PM – Thursday, June 2<sup>nd</sup> 2016.

Sealed proposals, subject to the request for proposals (RFP) documents hereto attached, for Maintenance/ Rehabilitation for the City of San Luis 300 K Gal. Tank (Well Site # 3) & 500 K Gal. Tank (Well Site # 4) are being accepted as set forth in this document.

By submitting a proposal, vendors (Offerors) hereby agrees to all of the terms and conditions of the RFP documents, and to all terms and conditions of the contract.

**OFFERORS IDENTIFICATION**

Revolution Industrial

---

Company Name

27-5034679

---

Federal I. D. # (Company Or Corporation)

480-244-9931

---

Telephone Number

480-718-7656

---

Facsimile Number

Tony Bodzoney

---

Contact Person

Project Manager

---

Title

6793 W. Willis Rd Box 5052

---

Complete Mailing Address

Chandler AZ

---

City & State

85226

---

Zip

6793 W. Willis RD

---

Complete Street Address

Chandler AZ

---

City & State

85226

---

Zip

**CITY OF SAN LUIS  
REQUEST FOR PROPOSALS  
No. PW-2016-01**

**300 K Gal. Tank (Well Site # 3) & 500 K Gal. Tank (Well Site # 4) Rehabilitation**

**EXHIBIT B**

COST PROPOSAL (No. PW-2016-01)

<b>A.) 300 K TANK REHABILITATION</b>					
ITEM	ITEM DESCRIPTION	QUANTITY	UNIT	AMOUNT	TOTAL
1	Interior Coating	1	lot	50,487.00	50,487.00
2	Disinfection/ Filling Tank	1	lot	500.00	500.00
3	1 Year Inspection	1	lot	500.00	500.00
	<i>Subtotal</i>				<b>\$ 51,487.00</b>
	<i>All Applicable Taxes</i>				<b>\$ 3,584.93</b>
	<i>Total Fixed Price</i>				<b>\$ 55,071.93</b>

<b>A.) 500 K TANK REHABILITATION</b>					
ITEM	ITEM DESCRIPTION	QUANTITY	UNIT	AMOUNT	TOTAL
1	Interior Coating	1	lot	60,900.55	60,900.55
2	Disinfection/ Filling Tank	1	lot	500.00	500.00
3	1 Year Inspection	1	lot	500.00	500.00
	<i>Subtotal</i>				<b>\$ 61,900.55</b>
	<i>All Applicable Taxes</i>				<b>\$ 4,240.38</b>
	<i>Total Fixed Price</i>				<b>\$ 65,140.93</b>

The undersigned by his/her signature represents that he/she is authorizes to bind the bidder to fully comply with the terms and conditions of the attached Proposal for the amount shown on the pricing sheet. By signing below, you have read the entire document and agreed to the terms therein.

Revolution Industrial  
 \_\_\_\_\_  
 COMPANY NAME

6793 W. Willis Rd. Chandler AZ 85226  
 \_\_\_\_\_  
 ADDRESS

*Tony Bodziany*  
 \_\_\_\_\_  
 PRINT NAME

*Tony Bodziany*  
 \_\_\_\_\_  
 SIGNATURE



## AGENDA ITEM REVIEW FORM

### Regular City Council Meeting

5. C.

**Meeting Date:** 06/08/2016

**Department Head:** Jennifer Cisneros, Acting Parks & Recreation Director, Parks & Recreation Department

**Submitted By:** Crystal Fragozo, Administrative Assistant, Parks & Recreation Department

**Action Requested:** Motion  
Public Hearing

---

### ITEM:

Public hearing followed by discussion and possible action on any and all matters regarding recommendation of a Special Event Liquor License application to the Arizona Department of Liquor Licenses and Control to authorize San Luis FRONTERA Rotary Club to sell alcohol on July 04, 2016.

**(Marcos Ramirez, President of the San Luis FRONTERA Rotary Club & Jennifer Cisneros, Acting Parks & Recreation Director)**

- A. Open public hearing
  - 1. Staff Presentation
  - 2. Call to the Public on this item
- B. Close public hearing
- C. Action on Special Event Liquor License Application to the Arizona Department of Liquor Licenses & Control

### SUMMARY:

San Luis FRONTERA Rotary Club wishes to sell beer on the July 04, 2016 festivities to raise funds for the applicant and the City of San Luis.

### RECOMMENDATION / SUGGESTED MOTION:

**I MOVE TO RECOMMEND TO THE ARIZONA DEPARTMENT OF LIQUOR LICENSES AND CONTROL APPROVAL OF THE SAN LUIS FRONTERA ROTARY CLUB APPLICATION AS PRESENTED.**

### Supporting information not attached to the Agenda Item Review Form:

Supporting information is attached to this Agenda Item Review Form

**Document to be Recorded?:** No

N/A

---

### Fiscal Impact

<b>IS THERE FISCAL IMPACT ASSOCIATED WITH THIS ITEM:</b>	Yes
<b>CITY/STATE/FEDERAL FUNDS:</b>	N/A
<b>TOTAL:</b>	N/A
<b>BUDGETED:</b>	N/A

**AVAILABLE TO TRANSFER:**

N/A

**GL ACCT # & NAME/REMAINING BALANCE BEFORE PURCHASE:** N/A

**FISCAL IMPACT STATEMENT (IF THIS IS A BUDGET TRANSFER, YOU MUST ATTACH THE BUDGET ADJUSTMENT FORM):**

The City will receive 25% of the proceeds.

---

**Attachments**

Special Event Liquor License Application

---

**APPLICATION FOR SPECIAL EVENT LICENSE**  
Fee= \$25.00 per day for 1-10 days (consecutive)  
A service fee of \$25.00 will be charged for all dishonored checks (A.R.S. §44-6852)

**IMPORTANT INFORMATION: This document must be fully completed or it will be returned.**

The Department of Liquor Licenses and Control must receive this application ten (10) business days prior to the event. If the special event will be held at a location without a permanent liquor license or if the event will be on any portion of a location that is not covered by the existing liquor license, this application must be approved by the local government before submission to the Department of Liquor Licenses and Control (see Section 15).

**SECTION 1** Name of Organization: San Luis FRONTERA Rotary Club

**SECTION 2** Non-Profit/IRS Tax Exempt Number: 86-0734186

**SECTION 3** The organization is a: (check one box only)

- Charitable (501.C)  Fraternal (must have regular membership and have been in existence for over five (5) years)  
 Religious  Civic (Rotary, College Scholarship)  Political Party, Ballot Measure or Campaign Committee

**SECTION 4** Will this event be held on a currently licensed premise and within the already approved premises?

- Yes  No

\_\_\_\_\_  
Name of Business License Number Phone (include Area Code)

**SECTION 5** How is this special event going to conduct all dispensing, serving, and selling of spirituous liquors? Please read R-19-318 for explanation (look in special event planning guide) and check one of the following boxes.

- Place license in non-use  
 Dispense and serve all spirituous liquors under retailer's license  
 Dispense and serve all spirituous liquors under special event  
 Split premise between special event and retail location

(If not using retail license, submit a letter of agreement from the agent/owner of the licensed premise to suspend the license during the event. If the special event is only using a portion of premise, agent/owner will need to suspend that portion of the premise.)

**SECTION 6** What is the purpose of this event?  On-site consumption  Off-site (auction)  Both

**SECTION 7** Location of the Event: Joe Orduño Park  
Address of Location: \_\_\_\_\_  
Street City County/State Zip  
965 N Park Ave San Luis Yuma/Arizona 85349

**SECTION 8** Will this be stacked with a wine festival/craft distiller festival?  Yes  No

**SECTION 9** Applicant must be a member of the qualifying organization and authorized by an Officer, Director or Chairperson of the Organization named in Section 1. (Authorizing signature is required in Section 13.)

1. Applicant: Ramirez Marcos 10-25 1988  
Last First Middle Date of Birth

2. Applicant's mailing address: PO BOX 13926 San Luis, Arizona 85349  
Street City State Zip

3. Applicant's home/cell phone: (928) 988-1110 Applicant's business phone: (928) 627-0005

4. Applicant's email address: marcosramirez5550@gmail.com

**SECTION 10**

1. Has the applicant been convicted of a felony, or had a liquor license revoked within the last five (5) years?  
 Yes  No (If yes, attach explanation.)

2. How many special event licenses have been issued to this location this year? 0  
 (The number cannot exceed 12 events per year; exceptions under A.R.S. §4-203.02(D).)

3. Is the organization using the services of a promoter or other person to manage the event?  Yes  No  
 (If yes, attach a copy of the agreement.)

4. List all people and organizations who will receive the proceeds. Account for 100% of the proceeds. The organization applying must receive 25% of the gross revenues of the special event liquor sales. Attach an additional page if necessary.

Name San Luis FRONTERA Rotary Club Percentage 75%  
 Address PO BOX 13926 San Luis Arizona 85349  
Street City State Zip

Name City of San Luis Percentage 25%  
 Address PO BOX 3750 San Luis Arizona 85349  
Street City State Zip

5. Please read A.R.S. §4-203.02 Special event license; rules and R19-1-205 Requirements for a Special Event License.

**Note: ALL ALCOHOLIC BEVERAGE SALES MUST BE FOR CONSUMPTION AT THE EVENT SITE ONLY.**

**"NO ALCOHOLIC BEVERAGES SHALL LEAVE SPECIAL EVENT UNLESS THEY ARE IN AUCTION SEALED CONTAINERS OR THE SPECIAL EVENT LICENSE IS STACKED WITH WINE /CRAFT DISTILLERY FESTIVAL LICENSE"**

6. What type of security and control measures will you take to prevent violations of liquor laws at this event?  
 (List type and number of police/security personnel and type of fencing or control barriers, if applicable.)

2 Number of Police 2 Number of Security Personnel  Fencing  Barriers

Explanation: Booth will be closed off with fencing. One main entrance and one main exit.

**SECTION 11** Date(s) and Hours of Event. May not exceed 10 consecutive days.  
 See A.R.S. §4-244(15) and (17) for legal hours of service.

	Date	Day of Week	Event Start Time AM/PM	License End Time AM/PM
DAY 1:	<u>7/4/2015</u>	<u>Monday</u>	<u>4:00 PM</u>	<u>11:59 PM</u>
DAY 2:	<u>7/5/2016</u>	<u>Tuesday</u>	<u>12:00 AM</u>	<u>1:00 AM</u>
DAY 3:	_____	_____	_____	_____
DAY 4:	_____	_____	_____	_____
DAY 5:	_____	_____	_____	_____
DAY 6:	_____	_____	_____	_____
DAY 7:	_____	_____	_____	_____
DAY 8:	_____	_____	_____	_____
DAY 9:	_____	_____	_____	_____
DAY 10:	_____	_____	_____	_____

**SECTION 12** License premises diagram. The licensed premises for your special event is the area in which you are authorized to sell, dispense or serve alcoholic beverages under the provisions of your license. The following space is to be used to prepare a diagram of your special event licensed premises. Please show dimensions, serving areas, fencing, barricades, or other control measures and security position.

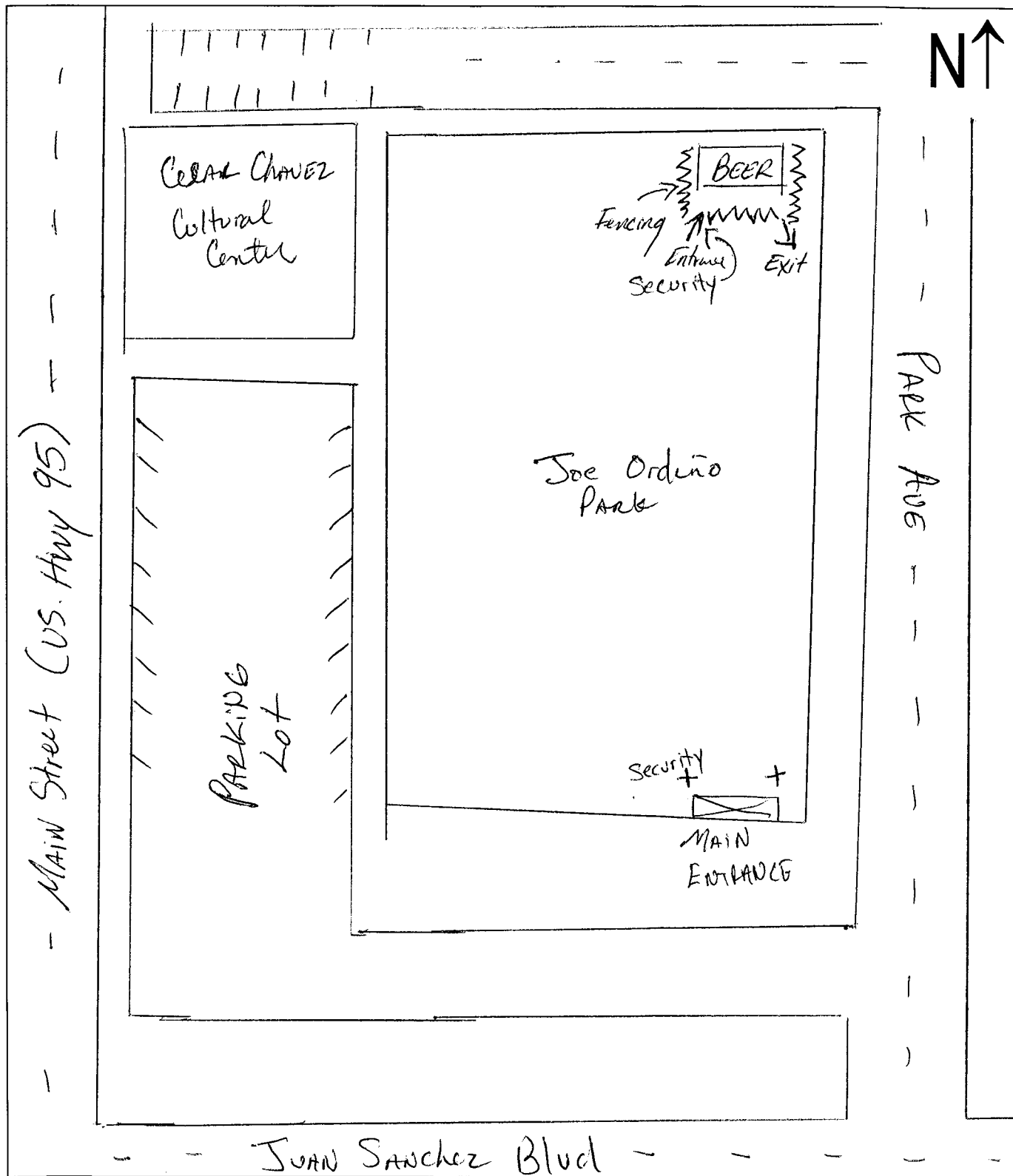

**SECTION 13** This section is to be completed only by an Officer, Director or Chairperson of the organization named in Section 1.

I, Marcos Ramirez declare that I am an OFFICER, DIRECTOR, or CHAIRPERSON  
(Print full name)  
appointing the applicant listed in Section 9, to apply on behalf of the foregoing organization for a Special Event  
Liquor License.

X [Signature] President 6-2-2016 928-988-1110  
(Signature) Title/ Position Date Phone #

The foregoing instrument was acknowledged before me this 2nd July 2016  
Day

State Arizona County of Yuma

My Commission Expires on: 5/10/2018  
Date

Melissa Lopez  
Signature of Notary Public



**SECTION 14** This section is to be completed only by the applicant named in Section 9.

I, Marcos Ramirez declare that I am the APPLICANT filing this application as  
(Print full name)  
listed in Section 9. I have read the application and the contents and all statements are true, correct and  
complete.

X [Signature] President 6-2-2016 928-988-1110  
(Signature) Title/ Position Date Phone #

The foregoing instrument was acknowledged before me this 2 July 2016  
Day

State Arizona County of Yuma

My Commission Expires on: 5/10/2018  
Date

Melissa Lopez  
Signature of Notary Public

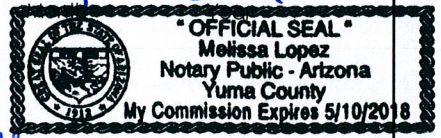

The local governing body may require additional applications to be completed and submitted. Please check with local government as to how far in advance they require these applications to be submitted. Additional licensing fees may also be required before approval may be granted. For more information, please contact your local jurisdiction: [http://www.azliquor.gov/assets/documents/homepage\\_docs/spec\\_event\\_links.pdf](http://www.azliquor.gov/assets/documents/homepage_docs/spec_event_links.pdf).

**SECTION 15** Local Governing Body Approval Section

I, \_\_\_\_\_ recommend  APPROVAL  DISAPPROVAL  
(government official) (Title)

on behalf of \_\_\_\_\_, \_\_\_\_\_, \_\_\_\_\_, \_\_\_\_\_  
(City, Town, County) Signature Date Phone

FOR DEPARTMENT OF LIQUOR LICENSES AND CONTROL USE ONLY

APPROVAL  DISAPPROVAL BY: \_\_\_\_\_ DATE: \_\_\_\_\_



# CERTIFICATE OF LIABILITY INSURANCE

7/1/2016

DATE (MM/DD/YYYY)  
06/02/2016

THIS CERTIFICATE IS ISSUED AS A MATTER OF INFORMATION ONLY AND CONFERS NO RIGHTS UPON THE CERTIFICATE HOLDER. THIS CERTIFICATE DOES NOT AFFIRMATIVELY OR NEGATIVELY AMEND, EXTEND OR ALTER THE COVERAGE AFFORDED BY THE POLICIES BELOW. THIS CERTIFICATE OF INSURANCE DOES NOT CONSTITUTE A CONTRACT BETWEEN THE ISSUING INSURER(S), AUTHORIZED REPRESENTATIVE OR PRODUCER, AND THE CERTIFICATE HOLDER.

IMPORTANT: If the certificate holder is an ADDITIONAL INSURED, the policy(ies) must be endorsed. If SUBROGATION IS WAIVED, subject to the terms and conditions of the policy, certain policies may require an endorsement. A statement on this certificate does not confer rights to the certificate holder in lieu of such endorsement(s).

<b>PRODUCER</b> LOCKTON COMPANIES 500 West Monroe, Suite 3400 CHICAGO IL 60661 (312) 669-6900	<b>CONTACT NAME:</b> Lockton Companies <b>PHONE (A/C, No., Ext):</b> 1-800-921-3172 <b>E-MAIL ADDRESS:</b> Rotary@lockton.com	<b>FAX (A/C, No.):</b> 1-312-681-6769
	<b>INSURER(S) AFFORDING COVERAGE</b>	
<b>INSURED</b> 1379367 All Active US Rotary Clubs & Districts Attn: Risk Management Department 1560 Sherman Ave. Evanston, IL 60201-3698	<b>INSURER A:</b> Westchester Fire Insurance Company	
	<b>INSURER B:</b>	
	<b>INSURER C:</b>	
	<b>INSURER D:</b>	
	<b>INSURER E:</b>	
	<b>INSURER F:</b>	

**COVERAGES** ROTIN01      **CERTIFICATE NUMBER:**      **REVISION NUMBER:**

THIS IS TO CERTIFY THAT THE POLICIES OF INSURANCE LISTED BELOW HAVE BEEN ISSUED TO THE INSURED NAMED ABOVE FOR THE POLICY PERIOD INDICATED. NOTWITHSTANDING ANY REQUIREMENT, TERM OR CONDITION OF ANY CONTRACT OR OTHER DOCUMENT WITH RESPECT TO WHICH THIS CERTIFICATE MAY BE ISSUED OR MAY PERTAIN, THE INSURANCE AFFORDED BY THE POLICIES DESCRIBED HEREIN IS SUBJECT TO ALL THE TERMS, EXCLUSIONS AND CONDITIONS OF SUCH POLICIES. LIMITS SHOWN MAY HAVE BEEN REDUCED BY PAID CLAIMS.

INSR LTR	TYPE OF INSURANCE	ADDL INSD	SUBR WVD	POLICY NUMBER	POLICY EFF (MM/DD/YYYY)	POLICY EXP (MM/DD/YYYY)	LIMITS
A	<input checked="" type="checkbox"/> <b>COMMERCIAL GENERAL LIABILITY</b> <input type="checkbox"/> CLAIMS-MADE <input checked="" type="checkbox"/> OCCUR <input checked="" type="checkbox"/> <b>Liquor Liability</b> Included GEN'L AGGREGATE LIMIT APPLIES PER: <input checked="" type="checkbox"/> POLICY <input type="checkbox"/> PRO-JECT <input type="checkbox"/> LOC OTHER:			PMI G23861355 007	7/1/2015	7/1/2016	EACH OCCURRENCE \$ 2,000,000 DAMAGE TO RENTED PREMISES (Ea occurrence) \$ 500,000 MED EXP (Any one person) \$ XXXXXXXX PERSONAL & ADV INJURY \$ 2,000,000 GENERAL AGGREGATE \$ 10,000,000 PRODUCTS - COMP/OP AGG \$ 4,000,000 \$
A	<input type="checkbox"/> <b>AUTOMOBILE LIABILITY</b> <input type="checkbox"/> ANY AUTO <input type="checkbox"/> ALL OWNED AUTOS <input type="checkbox"/> SCHEDULED AUTOS <input checked="" type="checkbox"/> HIRED AUTOS <input checked="" type="checkbox"/> NON-OWNED AUTOS			PMI G23861355 007	7/1/2015	7/1/2016	COMBINED SINGLE LIMIT (Ea accident) \$ 1,000,000 BODILY INJURY (Per person) \$ XXXXXXXX BODILY INJURY (Per accident) \$ XXXXXXXX PROPERTY DAMAGE (Per accident) \$ XXXXXXXX \$ XXXXXXXX
	<input type="checkbox"/> <b>UMBRELLA LIAB</b> <input type="checkbox"/> OCCUR <input type="checkbox"/> <b>EXCESS LIAB</b> <input type="checkbox"/> CLAIMS-MADE DED    RETENTION \$			NOT APPLICABLE			EACH OCCURRENCE \$ XXXXXXXX AGGREGATE \$ XXXXXXXX \$ XXXXXXXX
	<input type="checkbox"/> <b>WORKERS COMPENSATION AND EMPLOYERS' LIABILITY</b> <input type="checkbox"/> ANY PROPRIETOR/PARTNER/EXECUTIVE OFFICER/MEMBER EXCLUDED? (Mandatory in NH) if yes, describe under DESCRIPTION OF OPERATIONS below			NOT APPLICABLE			PER STATUTE    OTH-ER E.L. EACH ACCIDENT \$ XXXXXXXX E.L. DISEASE - EA EMPLOYEE \$ XXXXXXXX E.L. DISEASE - POLICY LIMIT \$ XXXXXXXX

**DESCRIPTION OF OPERATIONS / LOCATIONS / VEHICLES (ACORD 101. Additional Remarks Schedule, may be attached if more space is required)**

The Certificate Holder is included as Additional Insured where required by written and signed contract or permit subject to the terms and conditions of the General Liability policy, but only to the extent bodily injury or property damage is caused in whole or in part by the acts or omissions of the insured.

<b>CERTIFICATE HOLDER</b> City of San Luis 965 N. Park Avenue San Luis Frontera Rotary, District 5500. International Festival on 7/4/2016 in San Luis, AZ	<b>CANCELLATION</b> SHOULD ANY OF THE ABOVE DESCRIBED POLICIES BE CANCELLED BEFORE THE EXPIRATION DATE THEREOF, NOTICE WILL BE DELIVERED IN ACCORDANCE WITH THE POLICY PROVISIONS. AUTHORIZED REPRESENTATIVE 
---	--



## AGENDA ITEM REVIEW FORM

### Regular City Council Meeting

5. D.

**Meeting Date:** 06/08/2016

**Department Head:** Kay Macuil, City Attorney, Attorney's Office

**Submitted By:** Kay Macuil, City Attorney, Attorney's Office

**Action Requested:** Motion

---

### ITEM:

Discussion and possible action on any and all matters regarding reconsideration of Ordinance No. 354. An ordinance related to the Tax Code of the City of San Luis relating to the use Tax Rate for Purchases of Tangible Personal Property. **(Kay Marion Macuil, City Attorney)**

### SUMMARY:

City Council passed Ordinance No. 348, amending the San Luis Tax Code and providing for a tiered sales tax rate of 1.5% on single items costing \$2,500.00 or more while the sales tax on remaining items of lesser value have no change at 4%. Ordinance No. 348 went into effect on June 1, 2016.

The Department of Revenue required technical changes to include use taxes in the same tiered rate to comply with the U.S. Constitution Commerce Clause on interstate trade.

After discussion and review of language by two (2) tax experts, those changes were attempted in Ordinance No. 354. After the passage of Ordinance No. 354 at the May 25th Council Meeting, the Department of Revenue found another flaw in Ordinance No. 354. The effective date of August 1 is referring to the sales tax rather than the use tax.

In order to preserve the June 1st effective date of the tiered sales tax, staff is recommending that City Council reconsider its May 25th motion to pass Ordinance No. 354. Motions to reconsider must be made the next day that a business meeting is held. (See San Luis City Code §30.059(A)(1) and Robert's Rules of Order at RONR (11th ed.), p.76, III, 25-32).

For this June 8, 2016 Council Meeting there will need to be a two (2) step process. First there will be a motion to reconsider. If that motion passes then there will be a separate agenda item recommending a motion to deny Ordinance No. 354. After publication of notice of a new ordinance addressing the excise tax by itself, we will present that ordinance to Council for first and second reading. But again the sales tax portion can be preserved with the effective date on June 1 by reconsidering the approval of Ordinance No. 354 and in the agenda item following this one, denying Ordinance 354.

In order to preserve the June 1st effective date of the Tiered Sales Tax, staff recommends reconsideration of the May 25th motion approving Ordinance No. 354.

### RECOMMENDATION / SUGGESTED MOTION:

**I MOVE TO RECONSIDER THE MOTION OF MAY 25, 2016 WHICH APPROVED AND ADOPTED ORDINANCE NO. 354.**

**Supporting information not attached to the Agenda Item Review Form:**

Supporting documents are attached.

**Document to be Recorded?:** No

N/A

---

**Fiscal Impact**

**IS THERE FISCAL IMPACT ASSOCIATED WITH THIS ITEM:** N/A

**CITY/STATE/FEDERAL FUNDS:** N/A

**TOTAL:** N/A

**BUDGETED:** N/A

**AVAILABLE TO TRANSFER:** N/A

**GL ACCT # & NAME/REMAINING BALANCE BEFORE PURCHASE:** N/A

**FISCAL IMPACT STATEMENT (IF THIS IS A BUDGET TRANSFER, YOU MUST ATTACH THE BUDGET ADJUSTMENT FORM):**

Preserving the effective date of June 1, 2016 will create a reduction in tax for higher-priced items this month. This may attract businesses with higher-priced items to sell to locate in San Luis and so generate more sales tax revenue.

---

**Attachments**

Ordinance No. 354

---



# Ordinance

OFFICE OF THE  
MAYOR  
CITY OF SAN LUIS

NO. 354

**AN ORDINANCE OF THE MAYOR AND COUNCIL OF THE CITY OF SAN LUIS, ARIZONA AMENDING THE TAX CODE OF THE CITY OF SAN LUIS BY ADDING SUBSECTION 7A-460(d) RELATING TO THE SALES TAX RATE FOR RETAIL SALES OF TANGIBLE PERSONAL PROPERTY; ADDING SUBSECTION 7A-610(e) RELATING TO THE USE TAX RATE FOR PURCHASES OF TANGIBLE PERSONAL PROPERTY; ESTABLISHING AN EFFECTIVE DATE; REPEALING ORDINANCE NO. 348; REPEALING ANY CONFLICTING PROVISIONS; AND PROVIDING FOR SEVERABILITY.**

**WHEREAS**, the City Council of the City of San Luis, Arizona in order to relieve tax burdens placed upon the residents of the City of San Luis and to encourage economic growth desires to reduce the sales tax rate on certain retail sales of tangible personal property; and

**WHEREAS**, the Model City Tax Code makes provision for a difference in applicable rates for certain retail sales and purchases of tangible personal property as an available option to municipalities;

**NOW THEREFORE BE IT ORDAINED** by the Mayor and Council of the City of San Luis, Arizona as follows:

**Section 1:** The Tax Code of the City of San Luis is hereby amended by adding subsection 7A-460(d) to read as follows:

(d) Notwithstanding the provisions of subsection (a) above, when the gross income from the sale of a single item of tangible personal property exceeds two thousand five hundred dollars (\$2,500.00), the four percent (4%) tax rate shall apply to the first \$2,500.00. Above \$2,500.00, the measure of tax shall be at a rate of one and a half percent (1.5 %).

**Section 2:** The Tax Code of the City of San Luis is hereby amended by adding subsection 7A-610(e) to read as follows:

(e) Notwithstanding the provisions of subsection (a) above, when the amount subject to the tax for any single item of tangible personal property exceeds two thousand five hundred dollars (\$2,500.00), the four

percent (4%) tax rate shall apply to the first \$2,500.00. Above \$2,500.00, the measure of tax shall be at a rate of one and a half percent (1.5 %).

**Section 3:** The effective date of this adoption of subsection 7A-460(d) shall be August 1, 2016.

**Section 4:** Ordinance No. 348 is hereby specifically repealed, superseded, and replaced by this Ordinance.

**Section 5:** In the event of a conflict between the provisions of this Ordinance and any other ordinance, code, resolution, regulation, or policy of the City of San Luis, the conflicting provisions are hereby repealed, superseded and replaced.

**Section 6:** If any section, subsection, sentence, clause, phrase or portion of this ordinance or any part of these amendments to the tax code adopted herein is for any reason held to be invalid or unconstitutional by the decision of any court of competent jurisdiction, such decision shall not affect the validity of the remaining portions thereof.

PASSED AND ADOPTED by the Mayor and Council of City of San Luis, Arizona, on this \_\_\_\_\_ day of \_\_\_\_\_, 2016.

\_\_\_\_\_  
Gerardo Sanchez  
Mayor

ATTESTED:

APPROVED AS TO FORM:

\_\_\_\_\_  
Sonia Cornelio, City Clerk

\_\_\_\_\_  
Kay Marion Macuil, City Attorney



## AGENDA ITEM REVIEW FORM

### Regular City Council Meeting

5. E.

**Meeting Date:** 06/08/2016

**Department Head:** Kay Macuil, City Attorney, Attorney's Office

**Submitted By:** Kay Macuil, City Attorney, Attorney's Office

**Action Requested:** Motion

---

### ITEM:

Discussion and possible action on any and all matters regarding a motion to deny adoption of Ordinance No. 354. An ordinance related to the Tax Code of the City of San Luis relating to the use Tax Rate for Purchases of Tangible Personal Property. **(Kay M. Macuil, City Attorney)**

### SUMMARY:

City Council passed Ordinance No. 348, amending the San Luis Tax Code and providing for a tiered sales tax rate of 1.5% on single items costing \$2,500.00 or more while the sales tax on remaining items of lesser value have no change at 4%. Ordinance No. 348 went into effect on June 1, 2016.

The Department of Revenue required technical changes to include use taxes in the same tiered rate to comply with the U.S. Constitution Commerce Clause on interstate trade. After discussion and review of language by two (2) tax experts, those changes were attempted in Ordinance No. 354. After the passage of Ordinance No. 354 at the May 25th Council Meeting, the Department of Revenue found another flaw in Ordinance No. 354. The effective date of August 1 is referring to the sales tax rather than the use tax. In order to preserve the June 1st effective date of the tiered sales tax, staff is recommending that City Council deny passage of Ordinance No. 354. In order to preserve the June 1st effective date of the Tiered Sales Tax, staff recommends denial of passage of Ordinance No. 354.

### RECOMMENDATION / SUGGESTED MOTION:

**I MOVE TO DENY ADOPTION OF ORDINANCE NO. 354.**

### Supporting information not attached to the Agenda Item Review Form:

Supporting documents are attached.

**Document to be Recorded?:** No

N/A

---

### Fiscal Impact

<b>IS THERE FISCAL IMPACT ASSOCIATED WITH THIS ITEM:</b>	N/A
<b>CITY/STATE/FEDERAL FUNDS:</b>	N/A
<b>TOTAL:</b>	N/A
<b>BUDGETED:</b>	N/A
<b>AVAILABLE TO TRANSFER:</b>	N/A
<b>GL ACCT # &amp; NAME/REMAINING BALANCE BEFORE PURCHASE:</b>	N/A

**FISCAL IMPACT STATEMENT (IF THIS IS A BUDGET TRANSFER, YOU MUST ATTACH THE BUDGET ADJUSTMENT FORM):**

Preserving the effective date of June 1, 2016 will create a reduction in tax for higher-priced items this month. This may attract businesses with higher-priced items to sell to locate in San Luis and so generate more sales tax revenue.

---

**Attachments**

Ordinance No. 354

---



# Ordinance

OFFICE OF THE  
MAYOR  
CITY OF SAN LUIS

NO. 354

**AN ORDINANCE OF THE MAYOR AND COUNCIL OF THE CITY OF SAN LUIS, ARIZONA AMENDING THE TAX CODE OF THE CITY OF SAN LUIS BY ADDING SUBSECTION 7A-460(d) RELATING TO THE SALES TAX RATE FOR RETAIL SALES OF TANGIBLE PERSONAL PROPERTY; ADDING SUBSECTION 7A-610(e) RELATING TO THE USE TAX RATE FOR PURCHASES OF TANGIBLE PERSONAL PROPERTY; ESTABLISHING AN EFFECTIVE DATE; REPEALING ORDINANCE NO. 348; REPEALING ANY CONFLICTING PROVISIONS; AND PROVIDING FOR SEVERABILITY.**

**WHEREAS**, the City Council of the City of San Luis, Arizona in order to relieve tax burdens placed upon the residents of the City of San Luis and to encourage economic growth desires to reduce the sales tax rate on certain retail sales of tangible personal property; and

**WHEREAS**, the Model City Tax Code makes provision for a difference in applicable rates for certain retail sales and purchases of tangible personal property as an available option to municipalities;

**NOW THEREFORE BE IT ORDAINED** by the Mayor and Council of the City of San Luis, Arizona as follows:

**Section 1:** The Tax Code of the City of San Luis is hereby amended by adding subsection 7A-460(d) to read as follows:

(d) Notwithstanding the provisions of subsection (a) above, when the gross income from the sale of a single item of tangible personal property exceeds two thousand five hundred dollars (\$2,500.00), the four percent (4%) tax rate shall apply to the first \$2,500.00. Above \$2,500.00, the measure of tax shall be at a rate of one and a half percent (1.5 %).

**Section 2:** The Tax Code of the City of San Luis is hereby amended by adding subsection 7A-610(e) to read as follows:

(e) Notwithstanding the provisions of subsection (a) above, when the amount subject to the tax for any single item of tangible personal property exceeds two thousand five hundred dollars (\$2,500.00), the four

percent (4%) tax rate shall apply to the first \$2,500.00. Above \$2,500.00, the measure of tax shall be at a rate of one and a half percent (1.5 %).

**Section 3:** The effective date of this adoption of subsection 7A-460(d) shall be August 1, 2016.

**Section 4:** Ordinance No. 348 is hereby specifically repealed, superseded, and replaced by this Ordinance.

**Section 5:** In the event of a conflict between the provisions of this Ordinance and any other ordinance, code, resolution, regulation, or policy of the City of San Luis, the conflicting provisions are hereby repealed, superseded and replaced.

**Section 6:** If any section, subsection, sentence, clause, phrase or portion of this ordinance or any part of these amendments to the tax code adopted herein is for any reason held to be invalid or unconstitutional by the decision of any court of competent jurisdiction, such decision shall not affect the validity of the remaining portions thereof.

PASSED AND ADOPTED by the Mayor and Council of City of San Luis, Arizona, on this \_\_\_\_\_ day of \_\_\_\_\_, 2016.

\_\_\_\_\_  
Gerardo Sanchez  
Mayor

ATTESTED:

APPROVED AS TO FORM:

\_\_\_\_\_  
Sonia Cornelio, City Clerk

\_\_\_\_\_  
Kay Marion Macuil, City Attorney



## AGENDA ITEM REVIEW FORM

### Regular City Council Meeting

5. F.

**Meeting Date:** 06/08/2016

**Department Head:** Eulogio Vera, Public Works Director, Public Works Department

**Submitted By:** Eulogio Vera, Public Works Director, Public Works Department

**Action Requested:** Motion

---

### ITEM:

Discussion and possible action on any and all matters regarding the acceptance of bid for the extension of two 12" ductile iron discharge pipes at the east wastewater treatment plant. **(Eulogio Vera, Director of Public Works)**.

### SUMMARY:

Wastewater department has undertaken the task of expanding two 12" ductile iron discharge pipes at the east wastewater treatment plant. The extension of these pipe will assist with better metering the wastewater influent entering the treatment plant. Yuma Valley Contractors was the lowest of two bids with a total bid of \$78,000. Second bid was by LPC Construction and it came in at \$105,336.

### RECOMMENDATION / SUGGESTED MOTION:

**I MOVE TO ACCEPT THE BID AND APPROVE THE CONTRACT WITH YUMA VALLEY CONTRACTORS FOR AN AMOUNT NOT TO EXCEED \$78,000.00.**

### Supporting information not attached to the Agenda Item Review Form:

N/A

**Document to be Recorded?:** No

### Department

---

### Fiscal Impact

**IS THERE FISCAL IMPACT ASSOCIATED WITH THIS ITEM:** Yes  
**CITY/STATE/FEDERAL FUNDS:** City  
**TOTAL:** \$78,000  
**BUDGETED:** \$425,000  
**AVAILABLE TO TRANSFER:** 0  
**GL ACCT # & NAME/REMAINING BALANCE BEFORE PURCHASE:** Act# 310-311-90000.806  
**FISCAL IMPACT STATEMENT (IF THIS IS A BUDGET TRANSFER, YOU MUST ATTACH THE BUDGET ADJUSTMENT FORM):**

This project is to be funded by impact fees act # 310-311-90000.806

---

### Attachments

Bid Tab

Bid Package



Contractor	Recv'd On Time	Evidence (to do Bus.)	License Type B or Higher	Bid Amounts		
				North Tank	South Tank	Total Bid Price
Yuma Valley	Y / N	Y / N	Y / N	\$ 38,000.00	\$ 40,000.00	\$ 78,000.00
LPC	Y / N	Y / N	Y / N	\$ 52,568.00	\$ 52,768.00	\$ 105,336.00
	Y / N	Y / N	Y / N			
	Y / N	Y / N	Y / N			
	Y / N	Y / N	Y / N			
	Y / N	Y / N	Y / N			
	Y / N	Y / N	Y / N			
	Y / N	Y / N	Y / N			
<b>NOTES:</b>						

# **BID DOCUMENTS FOR EAST WASTEWATER TREATMENT PLANT (WWTP) PIPE RELOCATION**

**Prepared for:**



**City of San Luis  
1090 E. Union Street  
San Luis, AZ 85349**

**Prepared By:**



**Pacific Advanced Civil Engineering, Inc. (PACE)  
7434 E. McDonald Drive  
Scottsdale, AZ 85250**

**May 1016**

**BID FORM**

**City of San Luis  
San Luis, AZ  
East WWTP Pipe Relocation**

**Submitted By:**

**Contractor:** \_\_\_\_\_

**Date:** \_\_\_\_\_

**TABLE OF CONTENTS**

	<b>Page</b>
ARTICLE 1 – PROJECT DESCRIPTION.....	4
ARTICLE 2 – BID DUE DATE & RECIPIENT .....	4
ARTICLE 3 – BIDDER’S ACKNOWLEDGEMENTS .....	4
ARTICLE 4 – BIDDER’S REPRESENTATIONS.....	5
ARTICLE 5 – BIDDER’S CERTIFICATION .....	6
ARTICLE 6 – BASIS OF BID .....	6
ARTICLE 7 – TIME OF COMPLETION.....	7
ARTICLE 8 – BID SUBMITTAL.....	7

**ARTICLE 1 – PROJECT DESCRIPTION**

- 1.01 The City needs to reroute a 12” DIP that currently goes through three of the basin walls (14” +/- thick) and will now go over the walls on a support. Once pipe is rerouted, walls will need to be sealed.
- 1.02 Coordination with the City Staff and the selected Contractor on the E WWTP Basin Repair project will be required.
- 1.03 Contractor must comply with City regulations regarding insurance requirements, business licenses, contractor licensing, etc.
- 1.04 Technical Requirements
- A. Plans are attached as a part of this Bid Form. The plans only show the pipe relocation for the north tanks but the same is being required for the south tanks. Note 2 on the drawing is not applicable. This will require additional work of relocating the air piping. Note 3 on the drawings will apply to both the north and south tanks and pipe relocations as related to the existing openings that the pipe is currently passing through. There are 3 openings that need to be filled in each tank.
  - B. Intent is to reuse as much of the existing pipe as possible.
  - C. New pipe and fittings are to be cement lined per AWWA C104 and required primer shall be able to accept epoxy coating.
  - D. Pipe to be repainted with epoxy; color to match (City to select).
  - E. Submittals are required for beam, pipe, grout and paint for approval.
  - F. Steel beam to be primed and coated with epoxy to match pipe.
  - G. All labor, materials, equipment and incidentals necessary to complete this scope of work should be included in the two items below,

**ARTICLE 2 – BID DUE DATE & RECIPIENT**

- 2.01 Bid shall be received until 4:00 PM (local time) Thursday, May 26, 2016.
- 2.02 This Bid is submitted to:
- |                  |   |
|------------------|---|
|                  | City of San Luis                                  |
|                  | Public Works Department                           |
|                  | 1090 E. Union Street, San Luis, AZ 85349          |
| Mailing Address: | P.O. Box 1170, San Luis, AZ 85349-1170            |
| Attention:       | Mr. Manuel Rojas, Assistant Public Works Director |
| Envelope Marked: | EAST WWTP PIPE RELOCATION BID                     |
- 2.03 The undersigned Bidder proposes and agrees, if this Bid is accepted, to enter into an Agreement with Owner to perform all Work as specified or indicated in the Bidding Documents for the prices and within the times indicated in this Bid.

**ARTICLE 3 – BIDDER’S ACKNOWLEDGEMENTS**

- 3.01 This Bid will remain subject to acceptance for 60 days after the Bid opening, or for such longer period of time that Bidder may agree to in writing upon request of Owner.

**ARTICLE 4 – BIDDER’S REPRESENTATIONS**

4.01 In submitting this Bid, Bidder represents that:

- A. Bidder has examined and carefully studied the Bidding Documents, and any data and reference items identified in the Bidding Documents, and hereby acknowledges receipt of the following Addenda:

<u>Addendum No.</u>	<u>Addendum, Date</u>
_____	_____
_____	_____
_____	_____
_____	_____

- B. Bidder has visited the Site, conducted a thorough, alert visual examination of the Site and adjacent areas, and become familiar with and satisfied itself as to the general, local, and Site conditions that may affect cost, progress, and performance of the Work.
- C. Bidder is familiar with and has satisfied itself as to all Laws and Regulations that may affect cost, progress, and performance of the Work.
- D. Bidder has carefully studied, if available, all: (1) reports of explorations and tests of subsurface conditions at or adjacent to the Site and all drawings of physical conditions relating to existing surface or subsurface structures at the Site that have been identified in the Supplementary Conditions, especially with respect to Technical Data in such reports and drawings, and (2) reports and drawings relating to Hazardous Environmental Conditions, if any, at or adjacent to the Site that have been identified in the Supplementary Conditions, especially with respect to Technical Data in such reports and drawings.
- E. Bidder has considered the information known to Bidder itself; information commonly known to contractors doing business in the locality of the Site; information and observations obtained from visits to the Site; the Bidding Documents; and any Site-related reports and drawings identified in the Bidding Documents, with respect to the effect of such information, observations, and documents on (1) the cost, progress, and performance of the Work; (2) the means, methods, techniques, sequences, and procedures of construction to be employed by Bidder; and (3) Bidder’s safety precautions and programs.
- F. Bidder agrees, based on the information and observations referred to in the preceding paragraph, that no further examinations, investigations, explorations, tests, studies, or data are necessary for the determination of this Bid for performance of the Work at the price bid and within the times required, and in accordance with the other terms and conditions of the Bidding Documents.
- G. Bidder is aware of the general nature of work to be performed by Owner and others at the Site that relates to the Work as indicated in the Bidding Documents.
- H. Bidder has given Engineer written notice of all conflicts, errors, ambiguities, or discrepancies that Bidder has discovered in the Bidding Documents, and confirms that the written resolution thereof by Engineer is acceptable to Bidder.
- I. The Bidding Documents are generally sufficient to indicate and convey understanding of all terms and conditions for the performance and furnishing of the Work.

- J. The submission of this Bid constitutes an incontrovertible representation by Bidder that Bidder has complied with every requirement of this Article, and that without exception the Bid and all prices in the Bid are premised upon performing and furnishing the Work required by the Bidding Documents.

#### ARTICLE 5 – BIDDER’S CERTIFICATION

5.01 Bidder certifies that:

- A. This Bid is genuine and not made in the interest of or on behalf of any undisclosed individual or entity and is not submitted in conformity with any collusive agreement or rules of any group, association, organization, or corporation;
- B. Bidder has not directly or indirectly induced or solicited any other Bidder to submit a false or sham Bid;
- C. Bidder has not solicited or induced any individual or entity to refrain from bidding; and
- D. Bidder has not engaged in corrupt, fraudulent, collusive, or coercive practices in competing for the Contract. For the purposes of this Paragraph 4.01.D:
1. “corrupt practice” means the offering, giving, receiving, or soliciting of any thing of value likely to influence the action of a public official in the bidding process;
  2. “fraudulent practice” means an intentional misrepresentation of facts made (a) to influence the bidding process to the detriment of Owner, (b) to establish bid prices at artificial non-competitive levels, or (c) to deprive Owner of the benefits of free and open competition;
  3. “collusive practice” means a scheme or arrangement between two or more Bidders, with or without the knowledge of Owner, a purpose of which is to establish bid prices at artificial, non-competitive levels; and
  4. “coercive practice” means harming or threatening to harm, directly or indirectly, persons or their property to influence their participation in the bidding process or affect the execution of the Contract.

#### ARTICLE 6 – BASIS OF BID

6.01 Bidder will complete the Work in accordance with the Contract Documents for the following price(s):

##### BID SCHEDULE

Item	Description	Unit	Quantity	Bid Unit Price	Bid Price
1	North Tank	LS	1	\$	\$
2	South Tank	LS	1	\$	\$
3	<b>Total Bid Price</b>				\$

Bidder acknowledges that (1) each Bid Unit Price includes an amount considered by Bidder to be adequate to cover Contractor’s overhead and profit for each separately identified item, and (2) estimated quantities are not

guaranteed, and are solely for the purpose of comparison of Bids, and final payment for all unit price Bid items will be based on actual quantities, determined as provided in the Contract Documents.

**Total of Lump Sum and Unit Price Bids = Total Bid Price**     \$ \_\_\_\_\_

**ARTICLE 7 – TIME OF COMPLETION**

7.01 Bidder agrees that the time of completion for this project will be 21 calendar days from the Notice to Proceed.

**ARTICLE 8 – BID SUBMITTAL**

BIDDER: *[Indicate correct name of bidding entity]*

By: \_\_\_\_\_  
*[Signature]*

\_\_\_\_\_ *[Printed name]*

Attest: \_\_\_\_\_  
*[Signature]*

\_\_\_\_\_ *[Printed name]*

Title: \_\_\_\_\_

Submittal Date: \_\_\_\_\_

Address for giving notices:  
\_\_\_\_\_  
\_\_\_\_\_  
\_\_\_\_\_

Telephone Number: \_\_\_\_\_

Fax Number: \_\_\_\_\_

Contact Name and e-mail address: \_\_\_\_\_  
\_\_\_\_\_

Bidder's License No.: \_\_\_\_\_

Xref: A911-80\_1824.dwg  
 Dimstyle = 48; LStyle = 1; PStyle = 1; ACAD Ver. = 19.1s (LUS Tech); Version = 1

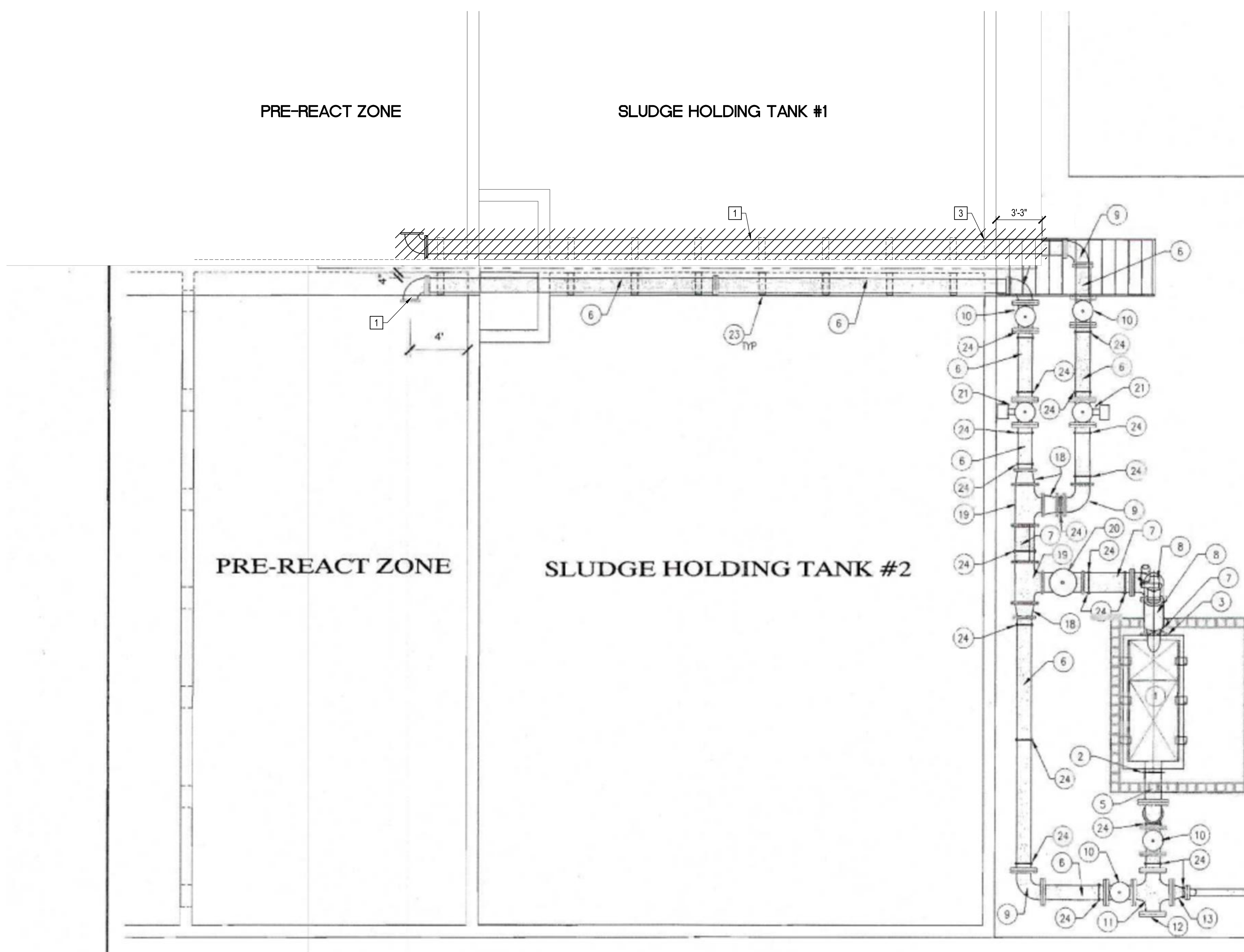

**DEMOLITION PLAN**  
SCALE: 1/4" = 1'-0"

**DEMOLITION NOTES**

- 1 REMOVE 12" DIP AND FITTINGS. CONTRACTOR TO REUSE PIPE PER SHEET M2.0.
- 2 CONTRACTOR TO ROTATE EX. ELBOW AND INSTALL DIP FLANGE x PE EXTENSION TO 12" BELOW TOP OF EX. WALL.
- 3 CONTRACTOR TO REPAIR CORED HOLE ONCE EX. PIPE IS REMOVED. CONTRACTOR SHALL HAVE A KEYWAY CHIPPED INTO THE EDGE OF THE OPENING ALL AROUND. THE HOLE SHALL BE FILLED WITH 5000 PSI NON-SHRINK GROUT.

	PREPARED BY <b>DUONG T. DO</b> PROJECT ENGINEER R.C.E. NO. -- 440050 EXP. 12/31/17	DRAWN K.V. DESIGNED D.T.D. CHECKED D.T.D.	SCALE  DATE MAY 2016	Expire: 12/31/17	NO.   BY   DATE   REVISIONS	DATE   APP.	
THESE DRAWINGS ARE THE PROPERTY OF P.A.C.E. AND SHALL NOT BE REPRODUCED IN ANY MANNER NOR BE USED FOR CONSTRUCTION UNLESS STAMPED "ISSUED FOR CONSTRUCTION".							
<b>CITY OF SAN LUIS EAST WASTEWATER TREATMENT PLANT SAN LUIS AZ</b>							
<b>INFLUENT PIPING DEMOLITION PLAN</b>							
17520 Newhops Street, Suite 200   Fountain Valley, CA 92708 P: (714) 481-7300   www.pacewater.com							
<b>M1.0</b>							
2 OF 2 SHEETS							
JOB NO. A911							

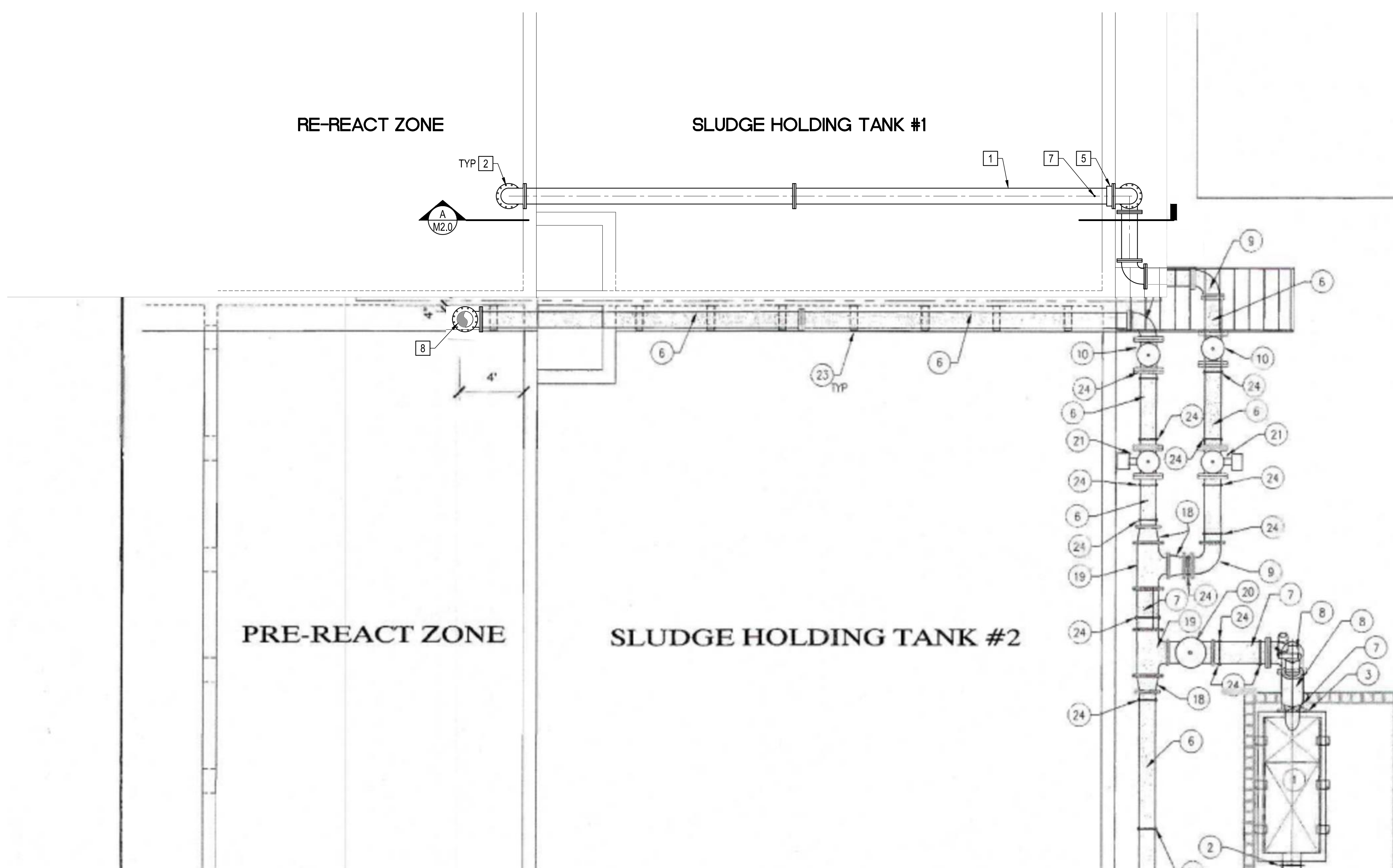

**PLAN**  
SCALE: 1/4"= 1'-0"

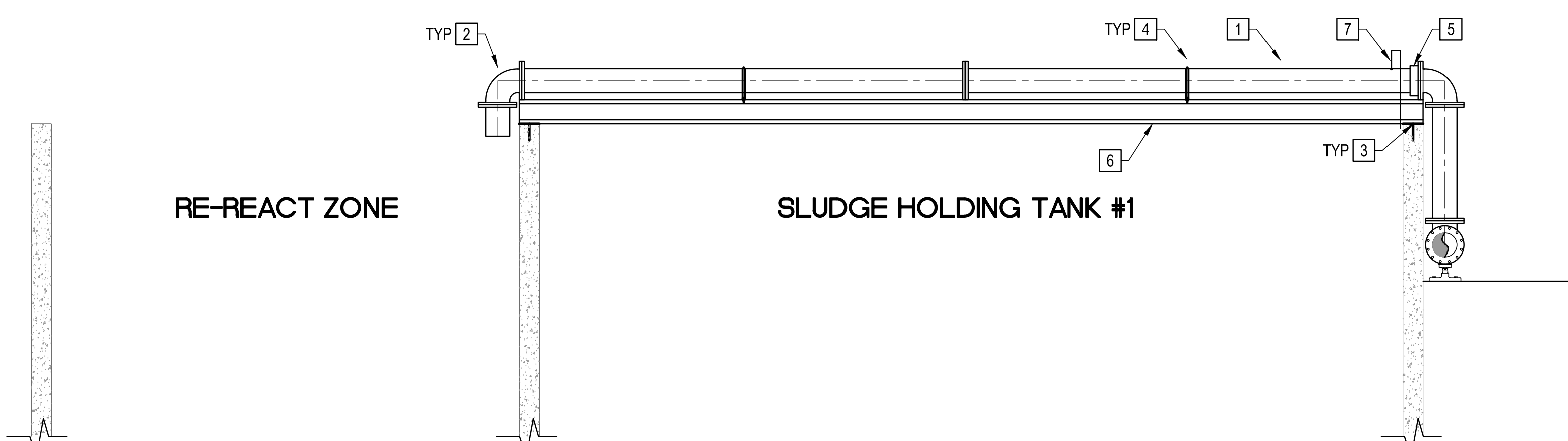

**SECTION A**  
SCALE: 1/4"= 1'-0"

**CONSTRUCTION NOTES**

- 1 INSTALL 12" DIP.
- 2 INSTALL 12" DIP 90° ELBOW.
- 3 I-BEAM TO BE WELDED TO 1/2" STEEL PLATE WITH 8" EMBEDDED 1/2" S.S. ANCHORS.
- 4 U-BOLT CLAMP PER DETAIL B HEREON.
- 5 INSTALL 12" FLANGE ADAPTER.
- 6 INSTALL W12x40 I-BEAM.
- 7 INSTALL 1" MANUAL AIR RELIEF VALVE PER DETAIL A HEREON.
- 8 CONTRACTOR TO ROTATE EX. ELBOW AND INSTALL DIP FLANGE x PE EXTENSION TO 12" BELOW TOP OF EX. WALL.

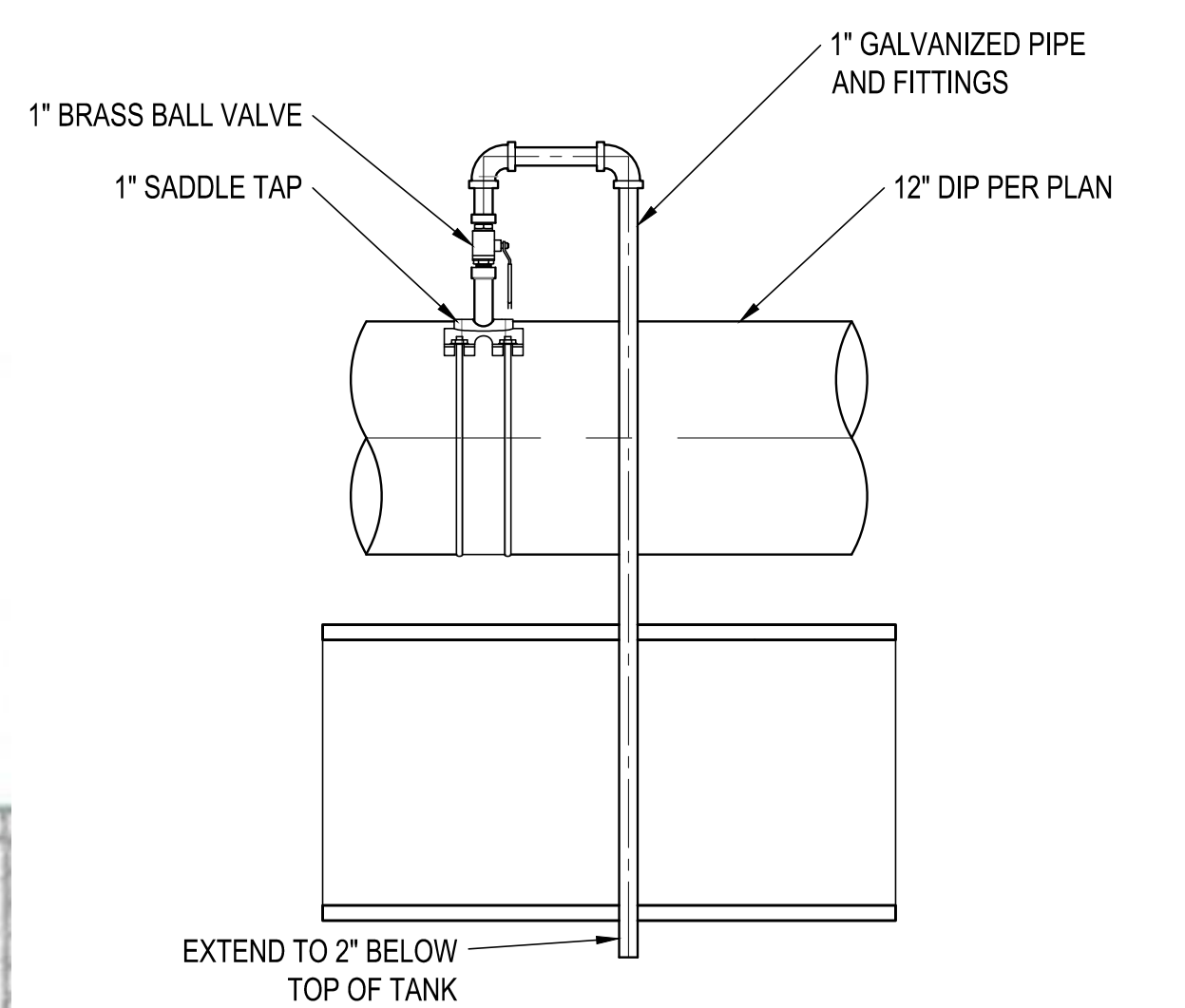

**DETAIL A**  
SCALE: NTS

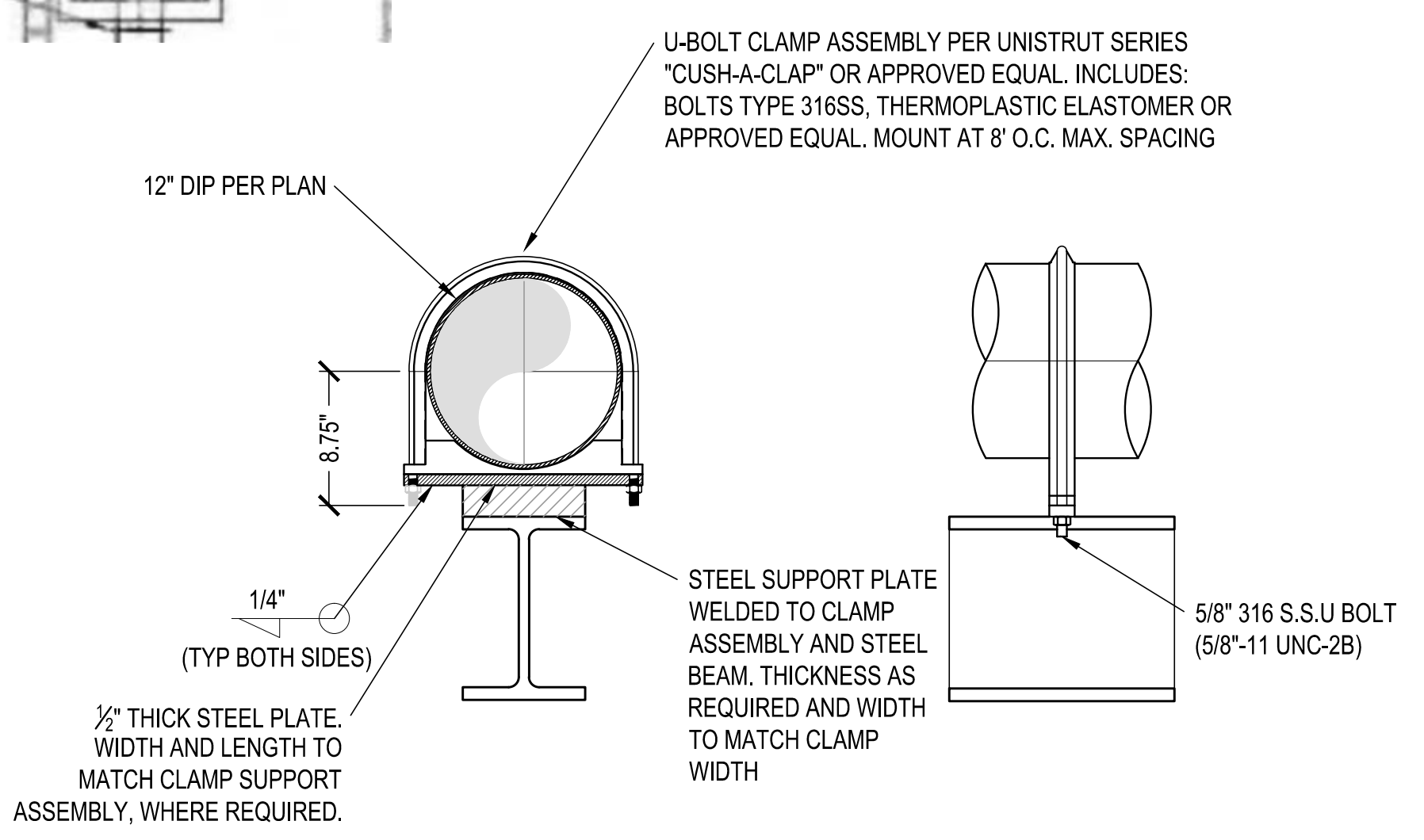

**DETAIL B**  
SCALE: NTS

NO.	BY	DATE	REVISIONS	DATE	APP.

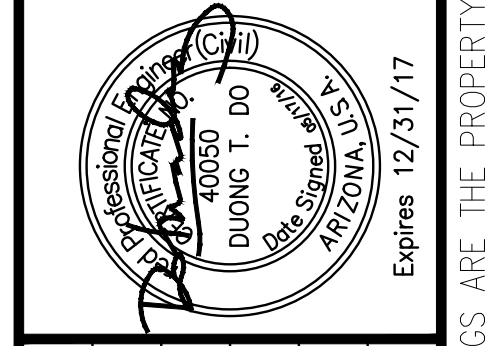

PREPARED BY DUONG T. DO	PROJECT ENGINEER R.G.E. NO. - 440050	SCALE	DATE MAY 2016
EXP. 12/31/17	DRAWN K.V.	DESIGNED D.T.D.	CHECKED D.T.D.

**INFLUENT PIPING MODIFICATIONS**

**CITY OF SAN LUIS EAST WASTEWATER TREATMENT PLANT SAN LUIS AZ**

**PACE**  
Advanced Water Engineering  
17520 Newhops Street, Suite 200 | Fountain Valley, CA 92708  
P: (714) 481-7300 | www.pacewater.com

Xref: A911-80-1824.dwg  
 Dimstyle = 48; Lstyle = 1; PStyle = 1; ACAD Ver. = 19.1s (LUS Tech); Viretion = 1

THESE DRAWINGS ARE THE PROPERTY OF P.A.C.E. AND SHALL NOT BE REPRODUCED IN ANY MANNER NOR BE USED FOR CONSTRUCTION UNLESS STAMPED "ISSUED FOR CONSTRUCTION".



## AGENDA ITEM REVIEW FORM

### Regular City Council Meeting

5. G.

**Meeting Date:** 06/08/2016

**Department Head:** John Starkey, Building Safety Director, Building & Safety

**Submitted By:** Jose A. Guzman, Assistant Planner, Development Services

**Action Requested:** Motion

Ordinance - 2nd Reading

---

### ITEM:

Discussion and possible action on any and all matters regarding Text Amendment Case No. 2016-0204 and Second Reading of Ordinance No. 350. An ordinance of the Mayor and Council of the City of San Luis, Arizona, amending the San Luis City Code, Chapter 152 Zoning Regulations, Section 152.259(B) and 152.260 relating to temporary signs and political signs; repealing any conflicting provisions; and providing for severability. **(John Starkey, Zoning Administrator)**

A. Approval of Second Reading of Ordinance No. 350 by title only

B. Approval and adoption of Ordinance No. 350

### SUMMARY:

This is a request by the City of San Luis for a text amendment to the San Luis City Code, Chapter 152 Zoning Regulations Sections 152.259 (B) and 152.260 relating to Temporary Signs and Political Signs.

The City of San Luis is requesting this text amendment in light of the Reed v. Town of Gilbert 135 S. Ct. 2218 (2015). In June 2015 the U.S. Supreme Court made a ruling in the case titled Reed v. Town of Gilbert which caused a significant change in approach to sign regulations that had previously been used in San Luis and many other localities across the state and country. The case involved a Sign Ordinance in the Town of Gilbert, Arizona that regulated signs differently according to content-based sign types, such as directional signs, ideological signs, and political signs. A church appealed the City's regulations because they were limited to certain size signs that they used to direct parishioners to their church, yet signs with other messages were allowed to be much larger. They argued that if the visual clutter is the concern being addressed with sign regulations, then the message on the sign should not make a difference and all types of signs should be treated fairly.

The Supreme Court held that any regulation that distinguishes signs based on what they say is considered to be content based, and content based regulations are legally subject to strict scrutiny and are thus only allowed if they are narrowly tailored to serve a compelling governmental interest and other avenues of communication are available for the user of the sign. Aesthetical and safety justifications are not enough of a reason for a sign regulation to survive strict scrutiny. The ruling basically says "if you have to read the sign to know if it complies with zoning, the regulation is invalid."

Because of this ruling, many aspects of the current Zoning Ordinance for signage have become unenforceable. While amendments are needed for all components of the signage regulations that relate to sign content or content-based sign categories, a pressing issue is that of signs in the public right-of-way.

Because the City currently allows certain signs in the right-of-way, it effectively has to allow all signs in the right-of-way. The City can no longer limit signage installations in the right-of-way to only political

campaign signs because it is content-based regulation. As a result, the City has been limited in its ability to enforce proliferation of other types of signs that have recently been placed in roadway medians and along the sides of streets.

The proposed text amendment would remove the language regarding political signs from the Zoning Ordinance and City Code, which currently recites the State Statute (A.R.S. §16-1019). The new language would simply say that political signs are regulated by the State and not the City. It does not say the signs are legal; rather that removal is controlled by state law. This amendment would eliminate the content-based treatment on the right-of-way under our Zoning Ordinance. Basically, by changing the language of political signs, there would be no signs allowed in the public right-of-way.

**CITIZEN REVIEW MEETING:**

The Citizen Review Meeting was held on May 3, 2016 at City Hall Multipurpose Room at 6 PM. The intent of this meeting was to allow the public to learn about the project, ask questions, and express comments. There were no members of the public present.

**ANALYSIS:**

In the wake of Reed, some things are clear. Governments still have an array content-neutral regulations to apply to signs. But, content-based distinctions such as the ones in the Town of Gilbert's code must survive strict scrutiny to stand, because of mix of opinions from the Court, there are several open questions. We will not know the full scope and meaning of Reed v. Town of Gilbert until the federal courts begin to apply this decision to other sign litigations.

In the mean while, this amendment will maximize the City's opportunity to defeat any challenges to the signs on right-of-way regulations as being content-based. This text amendment would make Section 16.1-E of the Zoning Ordinance enforceable again, therefore allowing the City to regulate the illegal signs currently placed on the right-of-way.

**PLANNING AND ZONING COMMISSION:**

The Planning and Zoning Commission held a public hearing for this item on their Regular Meeting of May 10, 2016. The Commission recommended approval of this request.

**CITY COUNCIL FIRST READING:**

On May 25, 2016, a Public Hearing was held and the First Reading of Ordinance No. 350 was approved by the City Council.

The purpose of this amendment is to enhance and maintain the aesthetical character, to promote the public health, safety and general welfare, and to increase the effectiveness of visual communication in the City. It is also intended to avoid visual clutter that may adversely impact traffic and pedestrian safety, or be adverse to property values, business opportunities and the City's appearance and to prevent and abate public nuisances.

**RECOMMENDATION / SUGGESTED MOTION:**

**A. I MOVE TO APPROVE SECOND READING OF ORDINANCE NO. 350 BY TITLE ONLY**

**B. I MOVE TO APPROVE AND ADOPT ORDINANCE NO. 350**

**Supporting information not attached to the Agenda Item Review Form:**

Supporting Ordinance Attached

**Document to be Recorded?:** Yes

**Fiscal Impact**

**IS THERE FISCAL IMPACT ASSOCIATED WITH THIS ITEM:** N/A  
**CITY/STATE/FEDERAL FUNDS:** N/A  
**TOTAL:** N/A  
**BUDGETED:** N/A  
**AVAILABLE TO TRANSFER:** N/A  
**GL ACCT # & NAME/REMAINING BALANCE BEFORE PURCHASE:** N/A  
**FISCAL IMPACT STATEMENT (IF THIS IS A BUDGET TRANSFER, YOU MUST ATTACH THE BUDGET ADJUSTMENT FORM):**  
N/A

---

**Attachments**

Ordinance No. 350

---



# Ordinance

No. 350

OFFICE OF THE  
MAYOR  
CITY OF SAN LUIS

**AN ORDINANCE OF THE MAYOR AND COUNCIL OF THE CITY OF SAN LUIS, ARIZONA, AMENDING THE SAN LUIS CITY CODE, CHAPTER 152 ZONING REGULATIONS, SECTIONS 152.259(B) AND 152.260 RELATING TO TEMPORARY SIGNS AND POLITICAL SIGNS; REPEALING ANY CONFLICTING PROVISIONS; AND PROVIDING FOR SEVERABILITY.**

**WHEREAS**, it is the desire of the City Council of the City of San Luis to have the regulation of signs conform to the holding of the U.S. Supreme Court in *Reed v. The Town of Gilbert*;

**NOW THEREFORE BE IT ORDAINED** by the mayor and council of the City of San Luis, Arizona, as follows:

**Section 1:** Section 152.259 of the Code of Ordinances of the City of San Luis, Arizona, is hereby amended to repeal subsection 152.259(B) in its entirety. Subsection 152,259 (C) shall be renumbered to be subsection 152.259 (B) and subsection 152.259 (D) shall be renumbered to be subsection 152.259 (C).

**Section 2:** Section 152.260 of the Code of Ordinances of the City of San Luis, Arizona, is hereby amended to read as follows:

§152.260 POLITICAL SIGNS ON PUBLIC STREETS

The Arizona Revised Statutes control the removal of political signs.

**Section 3:** In the event of a conflict between the provisions of this ordinance and any other ordinance, resolution, regulation, or policy within the City of San Luis, the conflicting provisions are hereby repealed, superseded, and replaced, and the provisions of this ordinance shall govern.

**Section 4:** If any section, subsection, sentence, clause, phrase, or portion of this ordinance is for any reason held to be invalid or unconstitutional by the final decision of any court of competent jurisdiction, such decision shall not affect the validity of the remaining portions of this ordinance or said reference regulations.

PASSED AND ADOPTED by the Mayor and City Council of the City of San Luis,  
Arizona, this \_\_\_\_\_ day of \_\_\_\_\_, 2016

\_\_\_\_\_  
Gerardo Sanchez, Mayor

ATTEST:

APPROVED AS TO FORM

\_\_\_\_\_  
Sonia Cornelio, City Clerk

\_\_\_\_\_  
Kay Marion Macuil, City Attorney



## AGENDA ITEM REVIEW FORM

### Regular City Council Meeting

8. A.

**Meeting Date:** 06/08/2016

**Department Head:** Kay Macuil, City Attorney, Attorney's Office

**Submitted By:** Kay Macuil, City Attorney, Attorney's Office

**Action Requested:**

---

#### ITEM:

Discussion and possible action to hold an executive session pursuant to A.R.S. §38-431.03(A)(3), A.R.S. §38-431.03(A)(4) and A.R.S. §38-431.03(A)(5) on any and all matters regarding discussion or consultation for legal advice with the City Attorney or City's attorneys to consider the City Council's position and instruct its Attorney or attorneys regarding staffing and or compensation contracts of public safety personnel of the San Luis Fire Department. **(Kay Marion Macuil, City Attorney)**

#### SUMMARY:

An executive session requested by the Mayor as described in the agenda item.

#### RECOMMENDATION / SUGGESTED MOTION:

**I MOVE TO HOLD AN EXECUTIVE SESSION PURSUANT TO A.R.S. §38-431.03(A) SUBSECTIONS (3), (4) AND (5).**

**Supporting information not attached to the Agenda Item Review Form:**

No attachments

**Document to be Recorded?:**

---

#### Fiscal Impact

**IS THERE FISCAL IMPACT ASSOCIATED WITH THIS ITEM:** N/A

**CITY/STATE/FEDERAL FUNDS:** N/A

**TOTAL:** N/A

**BUDGETED:** N/A

**AVAILABLE TO TRANSFER:** N/A

**GL ACCT # & NAME/REMAINING BALANCE BEFORE PURCHASE:** N/A

**FISCAL IMPACT STATEMENT (IF THIS IS A BUDGET TRANSFER, YOU MUST ATTACH THE BUDGET ADJUSTMENT FORM):**

There is no fiscal impact to this item because under A.R.S. §38-431.03(D) there can be no legal action involving a final vote or decision in executive session.

---



## AGENDA ITEM REVIEW FORM

### Regular City Council Meeting

8. B.

**Meeting Date:** 06/08/2016

**Department Head:** Kay Macuil, City Attorney, Attorney's Office

**Submitted By:** Kay Macuil, City Attorney, Attorney's Office

**Action Requested:** Motion

---

#### ITEM:

Discussion and possible action to hold an executive session pursuant to A.R.S. §38-431.03(A) subsection (3) and (4) on any and all matters relating to San Luis Facility Development Corporation versus CEC Federal Case No. CV 14-02633 PHX MEA and related contracts for discussion or consultation for legal advice with the City Attorney or City's attorneys and in order to consider the City's position and instruct its attorneys. **(Kay Marion Macuil, City Attorney)**

#### SUMMARY:

The law firm of Fenemore & Craig represents the San Luis Facility Development Corporation in San Luis Facility Development Corporation versus CEC Federal Case No. CV 14-02633 PHX MEA. Council can be properly advised by holding an executive session for the purposes described in the agenda item.

#### RECOMMENDATION / SUGGESTED MOTION:

**I MOVE TO HOLD AN EXECUTIVE SESSION PURSUANT TO A.R.S. §38-431.03(A) SUBSECTIONS (3) AND (4).**

#### Supporting information not attached to the Agenda Item Review Form:

No supporting information attached to the Agenda Item Review Form

**Document to be Recorded?:** No

N/A

---

#### Fiscal Impact

**IS THERE FISCAL IMPACT ASSOCIATED WITH THIS ITEM:** N/A

**CITY/STATE/FEDERAL FUNDS:** N/A

**TOTAL:** N/A

**BUDGETED:** N/A

**AVAILABLE TO TRANSFER:** N/A

**GL ACCT # & NAME/REMAINING BALANCE BEFORE PURCHASE:** N/A

**FISCAL IMPACT STATEMENT (IF THIS IS A BUDGET TRANSFER, YOU MUST ATTACH THE BUDGET ADJUSTMENT FORM):**

Fiscal impact is not applicable to this agenda item because under A.R.S. § 38-431.03(D), legal action involving a final vote or decision is not permitted to be taken at an executive session.

---





## AGENDA ITEM REVIEW FORM

### Regular City Council Meeting

8. C.

**Meeting Date:** 06/08/2016

**Department Head:** Kay Macuil, City Attorney, Attorney's Office

**Submitted By:** Kay Macuil, City Attorney, Attorney's Office

**Action Requested:** Motion

---

### ITEM:

Discussion and possible action to hold an Executive Session pursuant to A.R.S. §§38-431.03(A) subsections (3), (4), and (7) for legal advice and consider the City's position and instruct its Attorney with respect to two (2) potential projects the potential purchase of land, financing, and potential lease for a possible commercial development and possible commercial lease contracts that are the subject of negotiations for the Price Center Building. **(Kay Marion Macuil, City Attorney)**

### SUMMARY:

City Council can be properly advised by holding an executive session for the purposes described in the agenda item.

### RECOMMENDATION / SUGGESTED MOTION:

**I MOVE TO HOLD AN EXECUTIVE SESSION PURSUANT TO §§38-431.03(A) SUBSECTIONS (3), (4), AND (7).**

### Supporting information not attached to the Agenda Item Review Form:

No supporting information is attached.

**Document to be Recorded?:** No

N/A

---

### Fiscal Impact

**IS THERE FISCAL IMPACT ASSOCIATED WITH THIS ITEM:** N/A

**CITY/STATE/FEDERAL FUNDS:** N/A

**TOTAL:** N/A

**BUDGETED:** N/A

**AVAILABLE TO TRANSFER:** N/A

**GL ACCT # & NAME/REMAINING BALANCE BEFORE PURCHASE:** N/A

**FISCAL IMPACT STATEMENT (IF THIS IS A BUDGET TRANSFER, YOU MUST ATTACH THE BUDGET ADJUSTMENT FORM):**

Fiscal impact is not applicable to this agenda item because under A.R.S. §38-431.03(D), legal action involving a final vote or decision is not permitted to be taken at an executive session.

---



## AGENDA ITEM REVIEW FORM

### Regular City Council Meeting

8. D.

**Meeting Date:** 06/08/2016

**Department Head:** Kay Macuil, City Attorney, Attorney's Office

**Submitted By:** Kay Macuil, City Attorney, Attorney's Office

**Action Requested:** Motion

---

#### ITEM:

Discussion and possible action to hold an executive session pursuant to A.R.S. §38-431.03(A) subsections (1),(3) and (4) on any and all matters relating to the position of Magistrate to discuss or consider employment, assignment, appointment, including possible discussion of confirmation of appointment and/or discussion of approval of terms and/or conditions pursuant to San Luis City Code §34.20, and consultation with the City Attorney or City's attorneys regarding the same. **(Kay Marion Macuil, City Attorney)**

#### SUMMARY:

City Council can be properly advised by holding an executive session for the purposes described in the agenda item.

#### RECOMMENDATION / SUGGESTED MOTION:

**I MOVE TO HOLD AN EXECUTIVE SESSION PURSUANT TO A.R.S. §§38-431(A) SUBSECTIONS (1), (3) AND (4).**

#### Supporting information not attached to the Agenda Item Review Form:

There is no supporting information attached to this Agenda Item Review Form

**Document to be Recorded?:** No

N/A

---

#### Fiscal Impact

**IS THERE FISCAL IMPACT ASSOCIATED WITH THIS ITEM:** N/A

**CITY/STATE/FEDERAL FUNDS:** N/A

**TOTAL:** N/A

**BUDGETED:** N/A

**AVAILABLE TO TRANSFER:** N/A

**GL ACCT # & NAME/REMAINING BALANCE BEFORE PURCHASE:** N/A

**FISCAL IMPACT STATEMENT (IF THIS IS A BUDGET TRANSFER, YOU MUST ATTACH THE BUDGET ADJUSTMENT FORM):**

There is no fiscal impact to this item because under A.R.S. §38-431.03(D) there can be no legal action involving a final vote or decision in executive session.

---



## AGENDA ITEM REVIEW FORM

### Regular City Council Meeting

8. E.

**Meeting Date:** 06/08/2016

**Department Head:** Kay Macuil, City Attorney, Attorney's Office

**Submitted By:** Kay Macuil, City Attorney, Attorney's Office

**Action Requested:** Motion

---

### ITEM:

Discussion and possible action to hold an executive session pursuant to A.R.S. §§38-431.03(A) subsections (3), and (4) for discussion or consideration of any and all matters relating to the independent contract of the Consultant to the Interim City Manager and City Council to discuss or consider approval of amending terms and/or conditions and consultation with the City Attorney or City's attorneys regarding the same. **(Kay Marion Macuil, City Attorney)**

### SUMMARY:

City Council can be properly advised by holding an executive session for the purposes described in the agenda item.

### RECOMMENDATION / SUGGESTED MOTION:

**I MOVE TO HOLD AN EXECUTIVE SESSION PURSUANT TO A.R.S. §§38-431.03(A) SUBSECTIONS (3) AND (4).**

### Supporting information not attached to the Agenda Item Review Form:

There are no supporting documents attached.

**Document to be Recorded?:** No

N/A

---

### Fiscal Impact

**IS THERE FISCAL IMPACT ASSOCIATED WITH THIS ITEM:** N/A

**CITY/STATE/FEDERAL FUNDS:** N/A

**TOTAL:** N/A

**BUDGETED:** N/A

**AVAILABLE TO TRANSFER:** N/A

**GL ACCT # & NAME/REMAINING BALANCE BEFORE PURCHASE:** N/A

**FISCAL IMPACT STATEMENT (IF THIS IS A BUDGET TRANSFER, YOU MUST ATTACH THE BUDGET ADJUSTMENT FORM):**

There is no fiscal impact to this item because under A.R.S. §38-431.03(D) there can be no legal action involving a final vote or decision in executive session.

---

### Attachments

Independent Contractor Agreement 6/8/2016



## **INDEPENDENT CONTRACTOR AGREEMENT**

This agreement is effective this 1st day of May, 2016, at the City of San Luis, County of Yuma, State of Arizona, between The City of San Luis, Arizona, (“the City” or “San Luis”), a municipal corporation of the State of Arizona, 1090 E. Union Street, P.O. Box 1170, San Luis, Arizona, and Ralph Velez, referred to in this agreement as “Consultant.”

### **SECTION I TERM AND NATURE OF CONTRACT WORK**

The Consultant will begin working for the City as an Independent Contractor, on a part-time basis, as the Consultant to the Interim City Manager and City Council of the City of San Luis, Arizona beginning on the 1<sup>st</sup> day of May, 2016. He shall at all times serve at the pleasure of the City Council of the City of San Luis. The Consultant shall devote two-days per week to the performance of his duties as the Consultant to the Interim City Manager and City Council.

### **SECTION II CONSULTANT DUTIES**

The Consultant shall, subject to the direction and control of the City Council of the City of San Luis, take charge of the administration of the City and, jointly with the Interim City Manager, assist in the performance of the duties of the office of City Manager as set forth in the ordinances and Code of the City as well as the functions and duties specified in the applicable Arizona Statutes, including but not limited to ARS §9-303. The Consultant shall serve the City diligently and according to his best professional and personal abilities in all respects, and generally do all things for the best interests of the City that is usually done by persons occupying a position as the chief administrative officer of a political subdivision. The Consultant shall provide direction to the Interim City Manager and assist him in the performance of his job duties. Additionally, the Consultant shall consult with the City Council as the Consultant believes is needed and upon the City Council’s request. Consultant shall have use of a vehicle belonging to the City while working in San Luis, so long as the City has a vehicle that is in good operating condition that is available for use. Consultant shall travel to and from all locations and meetings necessary to satisfactorily perform his duties. The locations include, but are not limited to, the following: Border Trade Alliance, National League of Cities, Arizona League of Cities and Towns, Arizona Mexico Commission, the International Congress of Shopping Centers, and the National Association of Elected Officials. Consultant shall be reimbursed for all other reasonable travel related expenses when traveling to perform these duties for the City.

**SECTION III**  
**REIMBURSEMENT IN LIEU OF COMPENSATION**

A. **Salary.** The Consultant shall not be paid a salary for the performance of his duties, except when he performs official city business outside of Yuma County. For all such time he shall be paid \$65 per hour, and shall provide a weekly accounting to the Interim City Manager of such time. In lieu of a salary or hourly wage for work inside of Yuma County, Consultant shall receive per diem and reimbursement at the rates set forth in the remainder of this section.

B. **Mileage.** Consultant shall receive mileage reimbursement of \$0.55 per mile, for a maximum mileage of 362 miles traveled per week. Based on the mileage Consultant is expected to travel, the City shall pay Consultant a reimbursement of \$99.55 per day worked, for a total of \$199.10 per week. Consultant agrees to notify the Interim City Manager if he moves, or if he travels less than the expected amount of miles for any particular week, so that adjustments may be made to prevent overpayment.

C. **Lodging.** Consultant shall receive reimbursement for lodging at a rate of \$125.00 per day worked. Based on Consultant's agreement to work two days per week, the City shall reimburse Consultant \$250.00 per week. If Consultant works less than two days in any given week, for any reason, Consultant shall notify the Interim City Manager so that adjustments can be made to prevent overpayment. Additionally, Consultant shall be reimbursed for more than two days in a given week should Consultant incur such lodging expense for attendance at the Border Trade Alliance, National League of Cities, Arizona League of Cities and Towns, Arizona Mexico Commission, the International Congress of Shopping Centers, and the National Association of Elected Officials. Finally, when lodging outside of the Yuma County region, Consultant shall be reimbursed at the prevailing rate for such lodging, as determined by the Interim City Manager.

D. **Per Diem.** Consultant shall receive per diem at a rate of \$71.00 per day worked. Based on Consultant's agreement to work two days per week, the City shall reimburse Consultant \$142.00 per week. If Consultant works less than two days in any given week, for any reason, Consultant shall notify the Interim City Manager so that adjustments can be made to prevent overpayment. Additionally, Consultant shall also receive per diem at a rate of \$71.00 per day for attendance at the Border Trade Alliance, National League of Cities, Arizona League of Cities and Towns, Arizona Mexico Commission, the International Congress of Shopping Centers, and the National Association of Elected Officials.

E. **Payments.** The City shall issue Consultant reimbursement payments, and salary payments for work outside of Yuma County, bi-weekly in accordance with the City's usual payment and billing cycle. Based on the information listed in the preceding paragraphs, the City shall issue reimbursement payments in the amount of \$1,185.50 bi-weekly, except in the instances where additional reimbursement is required under Paragraphs (B), (C), or (D) above.

F. **Employment Benefits.** Based on Consultant’s status as an Independent Contractor, Consultant is not entitled to receive employment benefits. Consultant shall be responsible for obtaining health insurance and other employment benefits the City typically offers to its employees.

**SECTION IV  
OFFICE SPACE AND EQUIPMENT**

The City shall provide Consultant with office space, use of utilities, office supplies, a laptop computer, an iPad, and a telephone that will enable him to perform the functions of the position. Consultant shall return all office supplies and equipment immediately upon termination of this Agreement.

**SECTION V  
TERMINATION OF CONTRACT**

- A. The City Council may terminate this agreement at any time upon the giving of at least fourteen (14) days written notice to Consultant, unless the parties otherwise agree.
  
- B. Consultant may terminate this agreement at any time upon the giving of at least fourteen (14) days written notice to the Mayor and City Council, unless the parties otherwise agree.

**SECTION VI  
CONTRACT TERMS TO BE EXCLUSIVE**

This written agreement contains the sole and entire agreement between the parties and shall supersede any and all other agreements between the parties. The parties acknowledge and agree that neither of them has made any representation with respect to the subject matter of this agreement nor any representations inducing its execution and delivery except such representations as are specifically set forth in this writing and the parties acknowledge that they have relied on their own judgment in entering into the same. The parties further acknowledge that any statements or representations that may have been made by either of them to the other are void and of no effect and that neither of them has relied on such statements or representations in connection with its dealings with the other.

**SECTION VII  
WAIVER OR MODIFICATION INEFFECTIVE  
UNLESS IN WRITING**

It is agreed that no waiver or modification of this agreement or of any covenant, condition, or limitation contained in it shall be valid unless it is in writing and duly executed by the party to be charged with it, and that no evidence of any waiver or modification shall be offered or received in evidence in any proceeding, arbitration, or litigation between the parties arising out of or affecting this agreement, or the rights or obligations of any party

under it, unless such waiver or modification is in writing, duly executed as above. The parties agree that the provisions of this paragraph may not be waived except by a duly executed writing.

**SECTION VIII  
CONTRACT GOVERNED BY LAW OF  
STATE OF ARIZONA**

A. The parties agree that it is their intention and covenant that this agreement and performance under it and all suits and special proceedings relating to it be construed in accordance with and under and pursuant to the laws of the State of Arizona and that in any action, special proceeding, or other proceeding that may be brought arising out of, in connection with, or by reason of this agreement, the laws of the State of Arizona shall be applicable and shall govern to the exclusion of the law of any other forum, without regard to the jurisdiction in which any action or special proceeding may be instituted.

B. This agreement shall be subject to the cancellation provisions of ARS §38-511.

In witness whereof, the City of San Luis, Arizona has caused this agreement to be signed and executed on its behalf by its Mayor and duly attested to by its Clerk, and Ralph Velez, Consultant, has signed and executed this agreement at 1090 E. Union Street, San Luis, Arizona on the \_\_\_\_\_ day of June, 2016.

\_\_\_\_\_  
Ralph Velez, Consultant

The City of San Luis

By: \_\_\_\_\_

4838-6929-5153, v. 1



## AGENDA ITEM REVIEW FORM

### Regular City Council Meeting

10. A.

**Meeting Date:** 06/08/2016

**Department Head:** Kay Macuil, City Attorney, Attorney's Office

**Submitted By:** Kay Macuil, City Attorney, Attorney's Office

**Action Requested:** Motion

---

#### ITEM:

Discussion and possible action regarding any and all matters related to appointment of a Magistrate.  
**(Kay Marion Macuil, City Attorney)**

#### SUMMARY:

The proposed contract for a Magistrate will be provided by June 8, 2016. As of publication of this agenda, an offer had been extended to a candidate for Magistrate for recommendation to City Council.

#### RECOMMENDATION / SUGGESTED MOTION:

**I MOVE TO APPOINT \_\_\_\_\_ AS MAGISTRATE AND APPROVE AND ADOPT THE PROPOSED CONTRACT FOR MAGISTRATE .**

#### Supporting information not attached to the Agenda Item Review Form:

The proposed amendments to the Consultant's contract to be provided by 6/8/16.

**Document to be Recorded?:** No

N/A

---

#### Fiscal Impact

**IS THERE FISCAL IMPACT ASSOCIATED WITH THIS ITEM:** Yes  
**CITY/STATE/FEDERAL FUNDS:** City  
**TOTAL:** \$104,030  
**BUDGETED:** Yes  
**AVAILABLE TO TRANSFER:** N/A  
**GL ACCT # & NAME/REMAINING BALANCE BEFORE PURCHASE:** 100-160-50000

**FISCAL IMPACT STATEMENT (IF THIS IS A BUDGET TRANSFER, YOU MUST ATTACH THE BUDGET ADJUSTMENT FORM):**

The proposed magistrate contract is for \$85,000 per year plus benefits.

---

#### Attachments

Magistrate Contract 6/8/2016

---

**CITY OF SAN LUIS, ARIZONA**

**MAGISTRATE CONTRACT**

---

THIS CONTRACT is made and entered into this \_\_\_ day of June, 2016, and is effective June \_\_\_, 2016, by and between the CITY OF SAN LUIS, ARIZONA, a municipal corporation (hereinafter referred to as the "City"), as party of the first part, and Kristin McManus, hereinafter referred to as ("Magistrate"), as party of the second part, both of whom understand as follows:

WITNESSETH:

WHEREAS, the City desires to engage the services of Magistrate as the City Magistrate for the City of San Luis;

WHEREAS, the City Council will provide certain benefits and establish certain conditions of employment while Magistrate serves in this capacity; and

WHEREAS, it is the desire of the City Council to secure and retain the services of Magistrate, while providing a means for terminating Magistrate's services at such time as Magistrate may be unable to fully discharge Magistrate's duties or when the City or Magistrate may otherwise desire to terminate the employment relationship in accordance with law;

NOW, THEREFORE, in consideration of the mutual covenants herein contained, the parties hereto agree as follows:

**Section 1. Duties**

Magistrate shall perform the functions and duties specified in the City Code or as required by State Statute or Supreme Court Rule or Regulations. Magistrate shall also train Municipal Court Staff on judicial procedures and recordkeeping.

**Section 2. Term**

A. The parties agree that this appointment is for a term of two years.

B. Nothing in this Contract shall prevent, limit or otherwise interfere with the right of the City Council to terminate the services of Magistrate as provided by law, subject to the provisions set forth in Section 3 of this Contract.

C. Nothing in this contract shall prevent, limit or otherwise interfere with the right of Magistrate to resign at any time from her appointment as City Magistrate of the City, subject only to the provisions set forth in Section 3 of this Contract.

### **Section 3. Termination**

A. In the event Magistrate voluntarily terminates this appointment or good cause exists for the City to end the appointment prior to the expiration of the two-year term, the parties agree to give 30 days' notice in advance, or such advance notice as may otherwise be mutually agreed upon. In the event Magistrate is incapacitated in such a way that she is unable to perform the duties of the office with or without reasonable accommodation, and such incapacitation cannot reasonably be accommodated with an unpaid leave of absence, the City may terminate the appointment immediately.

B. This Contract automatically terminates at the end of the two-year term unless prior to the end of the term, the City Council and Magistrate enter into a new Contract governing a subsequent term of appointment.

### **Section 4. Compensation**

City agrees to pay Magistrate an annual salary of \$80,000, paid bi-weekly in the same manner and at the same time as City employees. Magistrate shall be entitled to all other employment benefits offered to other City employees.

### **Section 5. Hours of Work**

Magistrate shall work during such hours as are necessary to properly operate and maintain the Magistrate Court.

## **Section 6. Professional Development**

A. The City agrees to budget and to pay the travel and subsistence expenses of Magistrate for professional and official travel, meetings, and occasions adequate to continue the professional development of Magistrate and to adequately pursue necessary group and committee membership thereof.

B. The City also agrees to budget and pay for travel and subsistence expenses of Magistrate for courses, institutes and seminars that are necessary for professional development and for the good of the City.

C. It is acknowledged that the City may advance funds for training, and in the event Magistrate terminates the appointment, Magistrate agrees to reimburse the City for any sums advanced for the training.

## **Section 7. Other Terms and Conditions of Assignment**

A. City Council shall fix any such other terms and conditions of Magistrate's appointment as it may determine from time to time, relating to the performance of Magistrate, provided that such terms and conditions are not inconsistent with or in conflict with provisions of this Contract, the City Code, State Law or Supreme Court Rules or Regulations.

B. This Contract is contingent upon Magistrate's continued acceptability by the Arizona Supreme Court and any other regulatory body which governs magistrate courts in the state of Arizona. In the event Magistrate is unacceptable at any time for any reason(s) by the Arizona Supreme Court, this Contract is null and void. Magistrate agrees to advise the Mayor, City Management, and the City Attorney immediately should Magistrate receive any judicial conduct complaint, or should Magistrate become aware of any other matter that could possibly lead to removal from office, or otherwise result in not being able to fulfill her duties as the City Magistrate.

**Section 8. General Provisions**

A. The text herein shall constitute the entire agreement between the parties.

B. If any provision or any portion thereof contained in this Contract are held to be unconstitutional, invalid or unenforceable, the remainder of this Contract shall be deemed severable, shall not be affected and shall remain in full force and effect.

C. This agreement shall be subject to the cancellation provisions of ARS § 38-511.

\_\_\_\_\_  
Magistrate

CITY OF SAN LUIS

\_\_\_\_\_  
Mayor

ATTEST:

\_\_\_\_\_  
City Clerk

APPROVED AS TO FORM:

\_\_\_\_\_  
City Attorney

4813-4563-1282, v. 1



## AGENDA ITEM REVIEW FORM

### Regular City Council Meeting

10. B.

**Meeting Date:** 06/08/2016

**Department Head:** Kay Macuil, City Attorney, Attorney's Office

**Submitted By:** Kay Macuil, City Attorney, Attorney's Office

Action Requested:

---

#### ITEM:

Discussion and possible action regarding any and all matters related to amendments to the independent contract of Consultant to the Interim City Manager and to City Council. **(Kay Marion Macuil, City Attorney)**

#### SUMMARY:

Amendments proposed for the independent contract of the Consultant to the Interim City Manager and to the City Council will be provided by June 8, 2016.

#### RECOMMENDATION / SUGGESTED MOTION:

**I MOVE TO APPROVE THE PROPOSED AMENDMENTS TO THE CONTRACT OF THE CONSULTANT TO THE INTERIM CITY MANAGER AND TO THE CITY COUNCIL.**

#### Supporting information not attached to the Agenda Item Review Form:

The proposed amendments to the Consultant's contract to be provided by 6/8/16

#### Document to be Recorded?:

---

#### Fiscal Impact

<b>IS THERE FISCAL IMPACT ASSOCIATED WITH THIS ITEM:</b>	Yes
<b>CITY/STATE/FEDERAL FUNDS:</b>	City
<b>TOTAL:</b>	\$25,210.00
<b>BUDGETED:</b>	Yes
<b>AVAILABLE TO TRANSFER:</b>	N/A
<b>GL ACCT # &amp; NAME/REMAINING BALANCE BEFORE PURCHASE:</b>	Split
<b>FISCAL IMPACT STATEMENT (IF THIS IS A BUDGET TRANSFER, YOU MUST ATTACH THE BUDGET ADJUSTMENT FORM):</b>	

The amended contract allows for an additional \$65 per hour for official business out of the area of the City of San Luis and for an additional \$71 per day per diem for such travel as well as any associated mileage reimbursement. The amount can vary depending upon the official business that may arise out of the area.

Charge points will be: 100-110-80000 \$12,605.00  
100-115-80000 \$12,605.00

---

---

**Attachments**

Independent Contractor Agreement

---

---

## **INDEPENDENT CONTRACTOR AGREEMENT**

This agreement is made this \_\_\_\_ day of May, 2016, at the City of San Luis, County of Yuma, State of Arizona, between The City of San Luis, Arizona, (“the City” or “San Luis”), a municipal corporation of the State of Arizona, 1090 E. Union Street, P.O. Box 1170, San Luis, Arizona, and Ralph Velez, referred to in this agreement as “Consultant.”

### **SECTION I TERM AND NATURE OF CONTRACT WORK**

The Consultant will begin working for the City as an Independent Contractor, on a part-time basis, as the Consultant to the Interim City Manager and City Council of the City of San Luis, Arizona beginning on the 1<sup>st</sup> day of May, 2016. He shall at all times serve at the pleasure of the City Council of the City of San Luis. The Consultant shall devote two-days per week to the performance of his duties as the Consultant to the Interim City Manager and City Council.

### **SECTION II CONSULTANT DUTIES**

The Consultant shall, subject to the direction and control of the City Council of the City of San Luis, take charge of the administration of the City and, jointly with the Interim City Manager, assist in the performance of the duties of the office of City Manager as set forth in the ordinances and Code of the City as well as the functions and duties specified in the applicable Arizona Statutes, including but not limited to ARS §9-303. The Consultant shall serve the City diligently and according to his best professional and personal abilities in all respects, and generally do all things for the best interests of the City that is usually done by persons occupying a position as the chief administrative officer of a political subdivision. The Consultant shall provide direction to the Interim City Manager and assist him in the performance of his job duties. Additionally, the Consultant shall consult with the City Council as the Consultant believes is needed and upon the City Council’s request. Consultant shall have use of a vehicle belonging to the City while working in San Luis, so long as the City has a vehicle that is in good operating condition that is available for use. Consultant shall travel to and from all locations and meetings necessary to satisfactorily perform his duties. The locations include, but are not limited to, the following: Border Trade Alliance, National League of Cities, Arizona League of Cities and Towns, Arizona Mexico Commission, the International Congress of Shopping Centers, and the National Association of Elected Officials. Consultant shall be reimbursed for all other reasonable travel related expenses when traveling to perform these duties for the City.

**SECTION III**  
**REIMBURSEMENT IN LIEU OF COMPENSATION**

A. **Salary.** The Consultant shall not be paid a salary for the performance of his duties, except when he performs official city business outside of Yuma County. For all such time he shall be paid \$65 per hour, and shall provide a weekly accounting to the Interim City Manager of such time. In lieu of a salary or hourly wage for work inside of Yuma County, Consultant shall receive per diem and reimbursement at the rates set forth in the remainder of this section.

B. **Mileage.** Consultant shall receive mileage reimbursement of \$0.55 per mile, for a maximum mileage of 362 miles traveled per week. Based on the mileage Consultant is expected to travel, the City shall pay Consultant a reimbursement of \$99.55 per day worked, for a total of \$199.10 per week. Consultant agrees to notify the Interim City Manager if he moves, or if he travels less than the expected amount of miles for any particular week, so that adjustments may be made to prevent overpayment.

C. **Lodging.** Consultant shall receive reimbursement for lodging at a rate of \$125.00 per day worked. Based on Consultant's agreement to work two days per week, the City shall reimburse Consultant \$250.00 per week. If Consultant works less than two days in any given week, for any reason, Consultant shall notify the Interim City Manager so that adjustments can be made to prevent overpayment. Additionally, Consultant shall be reimbursed for more than two days in a given week should Consultant incur such lodging expense for attendance at the Border Trade Alliance, National League of Cities, Arizona League of Cities and Towns, Arizona Mexico Commission, the International Congress of Shopping Centers, and the National Association of Elected Officials. Finally, when lodging outside of the Yuma County region, Consultant shall be reimbursed at the prevailing rate for such lodging, as determined by the Interim City Manager.

D. **Per Diem.** Consultant shall receive per diem at a rate of \$71.00 per day worked. Based on Consultant's agreement to work two days per week, the City shall reimburse Consultant \$142.00 per week. If Consultant works less than two days in any given week, for any reason, Consultant shall notify the Interim City Manager so that adjustments can be made to prevent overpayment. Additionally, Consultant shall also receive per diem at a rate of \$71.00 per day for attendance at the Border Trade Alliance, National League of Cities, Arizona League of Cities and Towns, Arizona Mexico Commission, the International Congress of Shopping Centers, and the National Association of Elected Officials.

E. **Payments.** The City shall issue Consultant reimbursement payments, and salary payments for work outside of Yuma County, bi-weekly in accordance with the City's usual payment and billing cycle. Based on the information listed in the preceding paragraphs, the City shall issue reimbursement payments in the amount of \$1,185.50 bi-weekly, except in the instances where additional reimbursement is required under Paragraphs (B), (C), or (D) above.

F. **Employment Benefits.** Based on Consultant's status as an Independent Contractor, Consultant is not entitled to receive employment benefits. Consultant shall be responsible for obtaining health insurance and other employment benefits the City typically offers to its employees.

#### **SECTION IV OFFICE SPACE AND EQUIPMENT**

The City shall provide Consultant with office space, use of utilities, office supplies, a laptop computer, an iPad, and a telephone that will enable him to perform the functions of the position. Consultant shall return all office supplies and equipment immediately upon termination of this Agreement.

#### **SECTION V TERMINATION OF CONTRACT**

A. The City Council may terminate this agreement at any time upon the giving of at least fourteen (14) days written notice to Consultant, unless the parties otherwise agree.

B. Consultant may terminate this agreement at any time upon the giving of at least fourteen (14) days written notice to the Mayor and City Council, unless the parties otherwise agree.

#### **SECTION VI CONTRACT TERMS TO BE EXCLUSIVE**

This written agreement contains the sole and entire agreement between the parties and shall supersede any and all other agreements between the parties. The parties acknowledge and agree that neither of them has made any representation with respect to the subject matter of this agreement nor any representations inducing its execution and delivery except such representations as are specifically set forth in this writing and the parties acknowledge that they have relied on their own judgment in entering into the same. The parties further acknowledge that any statements or representations that may have been made by either of them to the other are void and of no effect and that neither of them has relied on such statements or representations in connection with its dealings with the other.

#### **SECTION VII WAIVER OR MODIFICATION INEFFECTIVE UNLESS IN WRITING**

It is agreed that no waiver or modification of this agreement or of any covenant, condition, or limitation contained in it shall be valid unless it is in writing and duly executed by the party to be charged with it, and that no evidence of any waiver or modification shall be offered or received in evidence in any proceeding, arbitration, or litigation between the parties arising out of or affecting this agreement, or the rights or obligations of any party under it, unless such waiver or modification is in writing, duly executed as above. The

parties agree that the provisions of this paragraph may not be waived except by a duly executed writing.

**SECTION VIII  
CONTRACT GOVERNED BY LAW OF  
STATE OF ARIZONA**

A. The parties agree that it is their intention and covenant that this agreement and performance under it and all suits and special proceedings relating to it be construed in accordance with and under and pursuant to the laws of the State of Arizona and that in any action, special proceeding, or other proceeding that may be brought arising out of, in connection with, or by reason of this agreement, the laws of the State of Arizona shall be applicable and shall govern to the exclusion of the law of any other forum, without regard to the jurisdiction in which any action or special proceeding may be instituted.

B. This agreement shall be subject to the cancellation provisions of ARS §38-511.

In witness whereof, the City of San Luis, Arizona has caused this agreement to be signed and executed on its behalf by its Mayor and duly attested to by its Clerk, and Ralph Velez, Consultant, has signed and executed this agreement at 1090 E. Union Street, San Luis, Arizona on the \_\_\_\_\_ day of June, 2016.

\_\_\_\_\_  
Ralph Velez, Consultant

CITY OF SAN LUIS

\_\_\_\_\_  
Mayor

ATTEST:

\_\_\_\_\_  
City Clerk

APPROVED AS TO FORM:

\_\_\_\_\_  
City Attorney