



NOTICE OF REGULAR COUNCIL MEETING

In accordance with §38-431.01 of the Arizona Revised Statutes of the State of Arizona, notice is hereby given to the Members of City Council and to the general public that the Mayor and Council of the City of San Luis, Arizona will hold a Regular City Council meeting at 7:00 p.m., Wednesday, May 22, 2019. The meeting will take place at the City Council Chambers, located at 1090 E. Union Street, San Luis, Arizona, 85349. Everyone from the public is invited to attend the open meeting.

In accordance with the Americans with Disabilities Act (ADA) and Section 504 of the Rehabilitation Act of 1973, the City of San Luis does not discriminate on the basis of disability in the admission of or access to, or treatment of employment in its programs, activities, or services. For information regarding rights and provisions of the ADA or Section 504, or to request reasonable accommodations for participation in City programs, activities or services contact: ADA/Section 504 Coordinator, City of San Luis Human Resources Department, 1090 E. Union Street, San Luis, Arizona, 85349; (928) 341-8520.

Notice is hereby given that pursuant to A.R.S. §1-602.A.9, subject to certain specified statutory exceptions, parents have a right to consent before the State or any of its political subdivisions make a video or audio recording of a minor child. Meetings of the City Council are audio and/or video recorded, and, as a result, proceedings in which children are present may be subject to such recordings. Parents in order to exercise their rights may either file written consent with the City Clerk to such recordings or take personal action to ensure that their child or children are not present when a recording may be made. If a child is present at the time a recording is made, the City will assume that the rights afforded parents pursuant to A.R.S. §1-602.A.9 have been waived.

THIS NOTICE IS GIVEN BY:

/s/ Sonia Cornelio, City Clerk

AVISO DE JUNTA REGULAR

De acuerdo con los Estatutos del Estado de Arizona A.R.S. §38-431.01, se le informa a los miembros del Cabildo y al público en general que el Alcalde y el Cabildo, tendrán una Junta Regular a las 7:00 p.m., el día Miercoles, 22 de Mayo del 2019. La junta se llevará a cabo en la Sala del Cabildo, ubicada en el 1090 E. Union Street, San Luis, Arizona, 85349. El público está cordialmente invitado a la junta.

De acuerdo con el Acta de Americanos con Discapacidades y la Sección 504 del Acta de Rehabilitación del 1973, la Ciudad de San Luis, Arizona no discrimina por causa de discapacidad la admisión y acceso a sus programas, actividades, servicios o en el trato en cuanto a empleo. Para más información referente a derechos y provisiones del Acta de Americanos con Discapacidades o Sección 504, o para solicitar adaptaciones que sean razonables para la participación en programas, actividades o servicios de la Ciudad, contactar al: Coordinador del Acta de Americanos con Discapacidades/Sección 504, Departamento de Recursos Humanos de la Ciudad de San Luis, Arizona, ubicado en el 1090 E. Union Street, San Luis, Arizona, 85349; (928) 341-8520.

Por medio de este aviso y de acuerdo con los Estatutos del Estado de Arizona A.R.S §1-602.A.9, sujeto a ciertas excepciones reglamentarias, los padres de familia tienen el derecho de dar el consentimiento ante el Estado o cualquiera de sus subdivisiones políticas para hacer una grabación de audio o video de su hijo menor de edad. Las juntas del Cabildo se graban en audio y/o video y como resultado, el hecho de que haya menores presentes puede ser sujeto a que sean grabados. Para que los padres de familia puedan ejercer sus derechos pueden dar el consentimiento por escrito con la Secretaria de la Ciudad a tal grabación, o tomar acción personal para asegurarse que su hijo menor no esté presente cuando la grabación se lleve a cabo. Si un menor de edad está presente en el momento de la grabación, la Ciudad asumirá que los padres de familia están cediendo los derechos sobre una posible grabación de acuerdo con los Estatutos del Estado de Arizona A.R.S. §1-602.A.9.

ESTE AVISO ES DADO POR:

/f/ Sonia Cornelio, Actuaría de la Ciudad



AGENDA
Regular Meeting
San Luis City Council
San Luis Council Chambers
1090 E. Union Street
San Luis, AZ 85349
May 22, 2019
7:00 p.m.

PLEASE TAKE NOTICE THAT MEMBERS OF THE CITY COUNCIL WILL ATTEND EITHER IN PERSON, TELEPHONE, OR VIDEO CONFERENCE COMMUNICATION. THE MAYOR OR ACTING MAYOR FOR THIS MEETING MAY CHANGE THE ORDER OF THE ITEMS; IF AUTHORIZED BY LAW AND BY A MAJORITY VOTE OF A QUORUM OF CITY COUNCIL MEMBERS PRESENT, AN EXECUTIVE SESSION WILL BE HELD IMMEDIATELY FOLLOWING THE VOTE IN ACCORDANCE WITH A.R.S. §38-431.03(A) AND THE MEETING WILL BE TEMPORARILY RECESSED WHILE THE CITY COUNCIL RETIRES TO EXECUTIVE SESSION WHICH WILL NOT BE OPEN TO THE PUBLIC.

- 1. CALL TO ORDER/ROLL CALL**
- 2. PLEDGE OF ALLEGIANCE**
- 3. INVOCATION**
- 4. PROCLAMATION**
 - 4. A.** Proclamation-National Public Works Week May 19-25, 2019
- 5. CONSENT AGENDA**

All matters are considered to be routine by the City Council and will be enacted by one motion. If discussion is desired, that item will be removed from the Consent Agenda and will be considered separately.
- 5. A. MINUTES OF**
 - Work Session held April 17, 2019
 - Regular Council meeting held April 24, 2019
- 5. B. DISBURSEMENTS FROM APRIL 27, 2019 THROUGH MAY 10, 2019.**

Total Disbursements \$587,710.99
(Five Hundred Eighty-Seven Thousand, Seven Hundred Ten Dollars and Ninety-Nine Cents)
- 6. DISCUSSION AND POSSIBLE ACTION ITEMS:**
 - 6. A.** Discussion and possible action on any and all matters regarding Resolution No. 2074. A resolution of the Mayor and City Council of the City of San Luis, Arizona directing the City Manager to establish and implement a plan for the fiscal year 2019-2020 for reduction in force and in civic contributions to ensure that city expenses do not exceed city revenues; superseding any conflicting provisions of the city; and providing for severability; and declaring an emergency. **(Tadeo A. De La Hoya, City Manager)**

- 6. B. Discussion and possible action on any and all matters regarding the ratification of the purchase for a new Emergency Incident Command Vehicle. **(Angel Ramirez, Fire Chief)**

- 6. C. Public hearing followed by discussion and possible action on any and all matters regarding the recommendation of a Special Event Liquor License application to the Arizona Department of Liquor Licenses and Control to authorize the City of San Luis Parks & Recreation Department to sell alcohol at the 4th of July Celebration to be held July 4, 2019. **(Lizandro Galaviz, Director of Parks and Recreation)**
 - A. Open public hearing
 - 1. Presentation by staff and/or applicant
 - 2. Call to the public on this item
 - B. Close public hearing
 - C. Action on Special Event Liquor License Application to the Arizona Department of Liquor Licenses & Control

- 6. D. Discussion and possible action on any and all matters regarding Order No. 2019-5. An order of the Mayor and City Council of the City of San Luis, Arizona implementing a uniform video and cable service license, a standard form application with an affidavit by mandate of the Arizona Legislature. **(Kay Marion Macuil, City Attorney)**

- 6. E. Public hearing followed by discussion and possible action on any and all matters regarding Rezoning Case No. 2019-0224 and Ordinance No. 390. An ordinance of the Mayor and City Council of the City of San Luis, Arizona, amending the official zoning map of the City of San Luis by changing the zoning classification of 30.3 acres from Medium-High Density Residential (R-2) to Medium Density Residential (R1-6) for property located on the northeast corner of County 24th Street and 20th Avenue. **(Jose A. Guzman, Director of Planning and Zoning)**
 - A. Open public hearing
 - 1. Staff presentation
 - 2. Call to the Public on this item
 - B. Close public hearing
 - C. Approval of Reading of Ordinance No. 390 by title only
(City Clerk to read the ordinance by title only)
 - D. Action on Ordinance No. 390

7. SUMMARY OF CURRENT EVENTS

Events by Mayor, Council Members and/or City Manager pursuant to A.R.S. §38-431.02 (K).

8. CALL TO THE PUBLIC

This is the time for the public to comment. Members of the City Council may not discuss items that are not specifically identified on the agenda. Therefore, pursuant to A.R.S. §38-431.01 (H), action taken as a result of public comment will be limited to directing staff to study the matter, responding to any criticism or scheduling the matter for further consideration and decision at a later date.

9. ADJOURNMENT



PROCLAMATION

Regular City Council Meeting

4.A.

Meeting Date: 05/22/2019

Title:

Proclamation-National Public Works Week May 19-25, 2019

Attachments

Proclamation-National Public Works Week



Proclamation

OFFICE OF THE
MAYOR
CITY OF SAN LUIS

National Public Works Week 2019 May 19 - 25, 2019

WHEREAS, public works professionals focus on infrastructure, facilities and services that are of vital importance to sustainable and resilient communities and to the public health, high quality of life and well-being of the people of Arizona; and

WHEREAS, these infrastructure, facilities and services could not be provided without the dedicated efforts of public works professionals, who are engineers, managers and employees from state and local governments and the private sector, who are responsible for rebuilding, improving and protecting our nation's transportation, water supply, water treatment and solid waste systems, public buildings, and other structures and facilities essential for our citizens: and,

WHEREAS, it is in the public interest for the citizens, civic leaders and children in the state of Arizona to gain knowledge of and to maintain a progressive interest and understanding of the importance of public works and public works programs in their respective communities,

WHEREAS, the American Public Work Association has celebrated the annual National Public Works Week since 1960,

NOW, THEREFORE, I, Gerardo Sanchez, Mayor of the City of San Luis, do hereby designate the week of May 19 through May 25, 2019 as National Public Works Week; I urge all our people to join with representatives of the American Public Works Association and government agencies in activities, events and ceremonies designed to pay tribute to our public works professionals, engineers, managers and employees and to recognize the substantial contributions they make to protecting our national health, safety, and quality of life.

PASSED AND ADOPTED, this _____ of May 2019.

Gerardo Sanchez, Mayor

ATTEST:

Sonia Cornelio, City Clerk



AGENDA ITEM REVIEW FORM

Regular City Council Meeting

5.A.

Meeting Date: 05/22/2019

Summary

MINUTES OF

-Work Session held April 17, 2019

-Regular Council meeting held April 24, 2019

Attachments

4/17/2019 WS

4/24/2019 RCM

MINUTES
Work Session
San Luis City Council
San Luis Council Chambers
1090 E. Union Street
April 17, 2019
6:30 p.m.

1. **CALL TO ORDER/ROLL CALL**: Mayor Gerardo Sanchez called the Work Session to order at approximately 6:32 p.m.

PRESENT: Mayor Gerardo Sanchez
Vice Mayor Maria Cecilia Ramos
Council Member Mario Buchanan Jr.
Council Member Africa Luna-Carrasco
Council Member Jose Ponce
Council Member Matias Rosales
Council Member Gloria Torres

OTHERS PRESENT: Tadeo A. De La Hoya, City Manager
Sonia Cornelio, City Clerk
Kay Marion Macuil, City Attorney
Angel Ramirez, Fire Chief
Aracely De La Hoya, Senior Services
Francia Alonso, Public Information Officer/Assistant to Council
Jenny Torres, Economic Development Manager
Jesus Meza, Assistant Director of Parks & Recreation
Jorge Mungaray, Information Technology
Jorge Perez, Billing & Collections Manager
Lizandro Galaviz, Director of Parks & Recreation
Monica Castro, Director of Finance
Ralph Velez, City Consultant
Richard Jessup, Chief of Police

2. **ITEMS FOR DISCUSSION ONLY**

2. A. Discussion and possible directions to staff on any and all matters regarding the December 19, 2018, Tischler Bise Draft Infrastructure Improvements Plan and Development Fee Report. (Monica Castro, Director of Finance and Tadeo A. De La Hoya, City Manager)

Mrs. Monica Castro, Director of Finance, presented the Mayor and Council with the Final Draft of the Infrastructure Improvements Plan and Development Fee Report. She informed that per Arizona Revised Statute Section 9-463.05 (D) it is required that the city updates its plan every 5 years, she added that the last study was made and adopted in 2014 and due for

an update this year. Mrs. Castro presented Mayor and Council with a power point presentation that included an overview of the Infrastructure Improvements Plan for Fire Department, General Government, Parks, Police, Streets, Water and Wastewater. A copy of this presentation is on file with the complete agenda packed filed in the Office of the City Clerk. Mrs. Castro informed that the proposed Development Fee for a single unit is \$5,232.00 with a variance (increase) of \$536.00 and for 2+ units is \$9,884.00 with a variance (decrease) of -\$1,478.00.

Mayor Gerardo Sanchez stated that the City of San Luis is considered one of the cheapest cities when it comes to Development Impact Fees.

Mrs. Castro informed that one of the factors for not increasing the fees is due to the city's growth.

Mayor Gerardo Sanchez asked Mrs. Castro if the calculation was calculated correctly, the reason he is asking is that the numbers are very attractive and in the future, he does not want staff to come and tell Council that there was a mistake during the calculations.

Mrs. Castro commented that Mr. Ben Griffin, the consultant, is very knowledgeable. There is no doubt that he has done an excellent job. She informed that Mr. Griffin met with all the department heads and discussed the cost and projects with all.

Mr. Ralph Velez, City Consultant, informed that department heads provided a "bucket list" from which it was easy to come up with the numbers. The consultant was able to come up with the numbers presented based on what staff believe is needed in the next 5 years to be spent over 10 years. Mr. Velez stated that 5 years ago Council decided not to raise water and sewer, and now we need those two and at this time water and sewer combined is less than sewer by itself. He added that the city needs sewer capacity.

Mayor Gerardo Sanchez stated that thanks to the conservative measures of staff and Council, water impact fees were added without a major impact.

Mrs. Kay Marion Macuil, City Attorney, informed that the next steps to follow after this meeting is to hold a public hearing, then adoption of the Infrastructure Improvements Plan and Development Fee Report, then hold another public hearing regarding fees and finally adoption of fees. She mentioned that the whole process will take up to December 2019 with an effective date 75 days after fees are adopted.

Mayor Gerardo Sanchez commended staff and everyone that participated in putting together this Report.

3. ADJOURNMENT

MOTION: Council Member Africa Luna-Carrasco to adjourn the meeting at approximately 7:06 p.m. Motion passed unanimously.

The vote was as follows:

Mayor Gerardo Sanchez	Aye
Vice Mayor Maria Cecilia Ramos	Aye
Council Member Mario Buchanan Jr.	Aye
Council Member Africa Luna-Carrasco	Aye
Council Member Jose Ponce	Aye
Council Member Matias Rosales	Aye
Council Member Gloria Torres	Aye

MINUTES
Regular Council Meeting
San Luis City Council
San Luis Council Chambers
1090 E. Union Street
April 24, 2019
7:00 p.m.

1. CALL TO ORDER/ROLL CALL: Mayor Gerardo Sanchez called the Regular City Council meeting to order at approximately 7:04 p.m.

PRESENT: Mayor Gerardo Sanchez
Vice Mayor Maria Cecilia Ramos
Council Member Mario Buchanan Jr.
Council Member Africa Luna-Carrasco
Council Member Jose Ponce
Council Member Matias Rosales
Council Member Gloria Torres

OTHERS PRESENT: Tadeo A. De La Hoya, City Manager
Sonia Cornelio, City Clerk
Kay Marion Macuil, City Attorney
Angel Ramirez, Fire Chief
Angelica Cifuentes, Purchasing Coordinator
Aracely De La Hoya, Senior Services Manager
Derek Dueñas, IT Manager
Edgar Carbajal, Recruitment Coordinator
Eulogio Vera, Director of Public Works
Fausto Gonzalez, Training and Programs Coordinator
Francia Alonso, PIO/Assistant to Council
Janet Taylor, Legal Secretary
Jesus Meza, Assistant Director of Parks & Recreation
Jonathan Dumadag, Senior IT Technician
Jorge Perez, Billing & Collections Manager
Jose Cisneros, Administrative Coordinator
Jose Guzman, Planning and Zoning Director
Marco Santana, Police Lieutenant
Maria Sabori, Risk Property Analyst
Monica Castro, Director of Finance
Monica Ruiz, Police Communications Supervisor
Richard Jessup, Chief of Police
Robert Solis, Fire Captain
Christian Cuevas, Simultaneous Interpreter
Concepcion Ulloa, Resident
Gullermina Fuentes, Resident
Lucy Lopez, Reporter

Maria Nuñez, Resident
Marco Pinzon, Resident
Maria Pinzon, Resident
Maria Robles, Resident

2. PLEDGE OF ALLEGIANCE

The Pledge of Allegiance was led by Council Member Gloria Torres.

3. INVOCATION

The Invocation was led by Mr. Richard Jessup, Chief of Police.

4. PROCLAMATIONS/PRESENTATIONS

4.A. Proclamation - Administrative Professionals Day April 24, 2019

Mrs. Sonia Cornelio, City Clerk, read the proclamation in its entirety.

Mayor Gerardo Sanchez congratulated all Administrative Professionals and stated that they are a big part of the city and thanked them for their professionalism and good customer service.

4.B. Proclamation - PPEP Tec High School - Cesar Chavez Learning Center

Mrs. Sonia Cornelio, City Clerk, read the proclamation in its entirety.

Mayor Gerardo Sanchez thanked PPEP Tec for their continued support and stated that they make an impact in the community.

Vice Mayor Maria Cecilia Ramos referenced to a situation in the community where a senior citizen needed assistance with her yard. She contacted PPEP Youth Build and they helped without hesitation with the cleaning of yard.

Ms. Monica Berumen, 211 Villa Street, San Luis, AZ, thanked the Mayor and City Council for the proclamation and wanted to clarify that they are the PPEP Tech Cesar Chavez Learning Center and are different from PPEP Youth Build, although they, PPEP Tech Cesar Chavez Learning Center has participated in different community events.

Mayor Gerardo Sanchez stated that he links all the PPEP Tech together as a team.

Council Member Gloria Torres mentioned that she graduated from PPEP Tech in 1988 and at that time it was not considered a high school but more of a technical career school.

Council Member Jose Ponce congratulated PPEP Tech and thanked them for their participation at various city events.

4.C. Proclamation - Municipal Clerks Week May 5-11, 2019

Mr. Tadeo De La Hoya, City Manager, read the proclamation in its entirety.

Mayor Gerardo Sanchez thanked Mrs. Sonia Cornelio, City Clerk and Mrs. Melissa Lopez, Deputy City Clerk for the service they provide to the city.

4.D. Presentation and recognition of the 2019 - 1st Quarter Awardees by the Employee Recognition and Awards Program (ERAP) for their outstanding work with the City of San Luis. (Lt. Marco Santana, Janet Taylor, ERAP Committee Chairs & Fausto Gonzalez, Training & Programs Coordinator)

Mr. Fausto Gonzalez, Training & Programs Coordinator, along with Mr. Marco Santana and Ms. Janet Taylor, ERAP Committee Chairs introduced the recipients for the years of service and awards.

Mayor Gerardo Sanchez congratulated all the recipients.

4.E. Introduction of the City of San Luis new hires for the 1st quarter from January through March 2019. (Edgardo Carbajal, HR Recruitment Coordinator)

Mr. Edgar Carbajal, HR Recruitment Coordinator, presented the 1st Quarter new hires from January through March 2019.

Mayor Gerardo Sanchez welcomed all the new hires.

5. CONSENT AGENDA

5. A. MINUTES OF

- Work Session held April 3, 2019
- Regular Council meeting held April 10, 2019

5. B. DISBURSEMENTS FROM APRIL 1, 2019 THROUGH APRIL 12, 2019.

Total Disbursements \$779,095.66

(Seven Hundred Seventy-Nine Thousand, Ninety-Five Dollars and Sixty-Six Cents)

6. DISCUSSION AND POSSIBLE ACTION ITEMS:

6.A. Discussion and possible action on any and all matters regarding a contract with the Greater Yuma Port Authority for reimbursement of construction of a waterline. (Eulogio Vera, Director of Public Works)

Mr. Eulogio Vera, Director of Public Works, explained that currently there is a contract with Taylor Engineering for installing two (2) miles of waterline in east San Luis. During the bidding process, Taylor Engineering provided good prices for the waterline installation. The City of San Luis is part of Greater Yuma Port Authority (GYPA) and needed over 700 linear water line installed. Therefore, a change order is needed to install the water line as part of the city's contract and GYPA will reimburse the city approximately \$33,500.00. Mr. Vera proceeded to explain the aerial of East Mesa waterline project slide attached to the agenda item review form.

MOTION: Vice Mayor Maria Cecilia Ramos/Council Member Jose Ponce to ratify the change order and approve the agreement with GYPA for reimbursement of construction of a waterline as presented. Motion passed unanimously.

The vote was as follows:

Mayor Gerardo Sanchez	Aye
Vice Mayor Maria Cecilia Ramos	Aye
Council Member Mario Buchanan Jr.	Aye
Council Member Africa Luna-Carrasco	Aye
Council Member Jose Ponce	Aye
Council Member Matias Rosales	Aye
Council Member Gloria Torres	Aye

6.B. Discussion and possible action on any and all matters regarding the City of San Luis accepting and ratifying slurry seal application services from American Pavement Preservation for application of Type 2 slurry seal as part of the 2019 Pavement Preservation Project. (Eulogio Vera, Director of Public Works)

Mr. Eulogio Vera, Director of Public Works, explained that this ratification is due to purchase order that needed to be issued in order for American Pavement Preservation to order the material and the work will begin on April 26, 2019. The slurry seal is performed twice a year and the \$120,000.00 covers for the second part of the pavement preservation program.

MOTION: Council Member Jose Ponce/Vice Mayor Maria Cecilia Ramos to approve the purchase of slurry seal application services through American Pavement Preservation for \$120,000.00. Motion passed unanimously.

The vote was as follows:

Mayor Gerardo Sanchez	Aye
Vice Mayor Maria Cecilia Ramos	Aye
Council Member Mario Buchanan Jr.	Aye
Council Member Africa Luna-Carrasco	Aye
Council Member Jose Ponce	Aye

Council Member Matias Rosales Aye
Council Member Gloria Torres Aye

6.C. Discussion and possible action on any and all matters regarding the approval of an engineering design proposal for the Cesar Chavez Boulevard and 10th Avenue intersection and traffic signal by Nicklaus Engineering, Inc. (Eulogio Vera, Director of Public Works)

Mr. Eulogio Vera, Director of Public Works, stated that Staff has been coordinating with Nicklaus Engineering, Inc. (NEI) to design intersection improvements for the Cesar Chavez Boulevard and 10th Avenue intersection. As part of the scope, NEI will be doing traffic counts for all four legs of the intersection and additionally some nearby driveways to the intersection that impact the functionality of the intersection.

Vice Mayor Maria Cecilia Ramos commented she is excited as this is something that they had been wanting for a long time as that area gets congested when all the schools that are beginning their day.

MOTION: Vice Mayor Maria Cecilia Ramos/Council Member Jose Ponce to approve the proposal from Nicklaus Engineering, Inc. in the amount of \$68,014.00 and direct staff to take all actions to finalize a contract. Motion passed unanimously.

The vote was as follows:

Mayor Gerardo Sanchez Aye
Vice Mayor Maria Cecilia Ramos Aye
Council Member Mario Buchanan Jr. Aye
Council Member Africa Luna-Carrasco Aye
Council Member Jose Ponce Aye
Council Member Matias Rosales Aye
Council Member Gloria Torres Aye

6.D. Discussion and possible action on any and all matters regarding the approval of an Engineering Design Proposal for the Cesar Chavez Boulevard and 6th Avenue traffic signal and intersection improvements by CORE Engineering Group, PLLC. (Eulogio Vera, Director of Public Works)

Mr. Eulogio Vera, Director of Public Works, said that staff has been coordinating with CORE Engineering to design intersection improvements for the Cesar Chavez Boulevard and 6th Avenue intersection. Project is budgeted in this fiscal year but the proposal is higher than anticipated. There are sufficient funds in the HURF account to cover the overage.

Vice Mayor Maria Cecilia Ramos added that it is exciting as the city will look different with all the signal lights and thanked Mr. Vera.

MOTION: Vice Mayor Maria Cecilia Ramos/Council Member Jose Ponce to approve CORE Engineering's Design Proposal for Cesar Chavez Boulevard and 6th Avenue intersection improvements in the amount of \$42,104.00 and direct staff to take all action need to finalize a contract. Motion passed unanimously.

The vote was as follows:

Mayor Gerardo Sanchez	Aye
Vice Mayor Maria Cecilia Ramos	Aye
Council Member Mario Buchanan Jr.	Aye
Council Member Africa Luna-Carrasco	Aye
Council Member Jose Ponce	Aye
Council Member Matias Rosales	Aye
Council Member Gloria Torres	Aye

6.E. Public hearing and discussion only regarding Annexation No. A-2019-01 a proposed annexation of territory contiguous to the municipal boundaries of the City of San Luis to include the area of southern Yuma County as shown on the map for annexation recorded at No. 2019-07705 Annexation of the Yuma County Recorder's Office on March 28, 2019. (Jose A. Guzman, Director of Planning & Zoning and Kay Marion Macuil, City Attorney)

A. Motion to open public hearing

MOTION: Council Member Mario Buchanan Jr./Council Member Gloria Torres to open the public hearing. Motion passed unanimously.

The vote was as follows:

Mayor Gerardo Sanchez	Aye
Vice Mayor Maria Cecilia Ramos	Aye
Council Member Mario Buchanan Jr.	Aye
Council Member Africa Luna-Carrasco	Aye
Council Member Jose Ponce	Aye
Council Member Matias Rosales	Aye
Council Member Gloria Torres	Aye

1. Presentation by staff

Mr. Tadeo De La Hoya, City Manager, explained that in March 2019 he met with the County Managers and Mayors and the subject of annexations and growth was discussed. He consulted with the Planning & Zoning and Legal Departments and was informed that an annexation was done in 2008. The understanding was that the proposed annexation had already been done and it was discovered that it was never recorded or no action was taken due to the turn-over of the Director of Planning & Zoning back then, so now this aligns with the city's general plan. The city filed a blank proposed annexation up to Avenue 10E to be aligned with the limits of the City of Yuma. The city has complied with the statutes by advertising it in the Yuma Sun, mailing notices to all the tax payers in the property and posting three (3) posters within the property. Most of the land is owned by Bureau of Land Management (BLM) and Bureau of Reclamation (BOR) and the city is working with both agencies. The city has until March 27, 2020 to gather the required signatures to annex the proposed area.

Mayor Gerardo Sanchez asked Mr. Jose Guzman, Director of Planning & Zoning, if there were any objections or concerns received.

Mr. Guzman responded that he received a few telephone calls with questions regarding the annexation. His office mailed more detailed information, such as maps, that answered those questions; there was no opposition. He spoke with the Marine Corps. Air Station and they stated that they needed more time to review as they had to speak to their supervisors and get some comments.

Mayor Gerardo Sanchez added that the city cannot change the Yuma Proving Grounds as it is federal land.

2. Call to the public to take all written and oral public comments on this item.

Ms. Gabby Black, Community Planning & Liaison Officer for Marine Corps. Air Station of Yuma, stated that they had seen the notice on the local newspaper and reached out to BLM and BOR for their notices. They did have some concerns, however, they have not had enough time to evaluate it properly and analyze it because there are some regulations that govern them when it comes to annexation of military or federal land. They noticed that over half of the land includes the Barry M. Goldwater Range. They have some questions and want to set up a meeting with the City of San Luis representatives to discuss this further. At this time their official response is that they want to request more time to analyze it and discuss it with the city.

Mr. De La Hoya stated that the city can meet with them as soon as the Marine Corps. notifies the city when they are available to meet.

Mayor Gerardo Sanchez mentioned that this has been going on since 2008 and believes there was a legal case between the Cities of San Luis and Yuma at that time. Mr. De La Hoya responded it was in 1998 and for a different part.

B. Motion to close public hearing

MOTION: Council Member Jose Ponce/Council Member Africa Luna-Carrasco to close the public hearing. Motion passed unanimously.

The vote was as follows:

Mayor Gerardo Sanchez	Aye
Vice Mayor Maria Cecilia Ramos	Aye
Council Member Mario Buchanan Jr.	Aye
Council Member Africa Luna-Carrasco	Aye
Council Member Jose Ponce	Aye
Council Member Matias Rosales	Aye
Council Member Gloria Torres	Aye

Mayor Gerardo Sanchez asked if further action was needed from the City Council. Mr. De La Hoya responded no, unless the City Council wants staff to bring it back to consider it further or to pull the annexation that the city filed.

Ms. Kay Macuil, City Attorney, added that this is solely for public comment but the City Council can always direct staff to do something they might have in mind.

Mayor Gerardo Sanchez said it is very important that staff meet with the parties involved.

6.F. Public hearing followed by discussion and possible action on any and all matters regarding Conditional Use Permit Case No. 2019-067. A request by Glen T. Curtis on behalf of MJS Properties, L.T.D., property owner, for a Conditional Use Permit to allow the establishment of a religious institution to be located on the northeast corner of 5th Avenue and Union Street. (Jose A. Guzman, Director of Planning and Zoning)

A. Open public hearing

MOTION: Council Member Gloria Torres/Council Member Africa Luna-Carrasco to open the public hearing. Motion passed unanimously.

The vote was as follows:

Mayor Gerardo Sanchez	Aye
Vice Mayor Maria Cecilia Ramos	Aye
Council Member Mario Buchanan Jr.	Aye
Council Member Africa Luna-Carrasco	Aye
Council Member Jose Ponce	Aye
Council Member Matias Rosales	Aye
Council Member Gloria Torres	Aye

1. Staff Presentation

Mr. Jose Guzman, Director of Planning & Zoning, explained that this is a conditional use to allow a religious institution, Iglesia Apostolica de La Fe en Cristo Jesus in the USA, to be located at the corner of Union Street and 5th Avenue. The proposed building is 8,843 square feet to be located in an approximately 2-acre lot within a portion of Assessor's Parcel ID Number 226-01-001. Assessor's Parcel ID Number 226-01-001 is one parcel containing approximately 150 acres. Said parcel covers territory between the southeast corner of County 22nd Street and 4th Avenue and the northwest corner of Union Street and 6th Avenue. Although the land is physically separated by the East Main Canal and the Main Drain in different sections, it is only one parcel as per the Yuma County records.

This church will have approximately 160-180 members and will have services on Wednesdays and Sundays. Because the conditional use permit is being processed first, staff recommends the approval of the conditional use that will become effective until the lot split is approved and recorded. This was presented to the Planning & Zoning Commission and agreed with staff's recommendation. He mailed 30 letters to property owners within 300 feet of the proposed project and his office did not receive any significant concerns or objections from the adjacent property owners.

2. Call to the Public on this item

There were no comments from the public on this item.

B. Close public hearing

MOTION: Council Member Africa Luna-Carrasco/Vice Mayor Maria Cecilia Ramos to close the public hearing. Motion passed unanimously.

The vote was as follows:

Mayor Gerardo Sanchez	Aye
Vice Mayor Maria Cecilia Ramos	Aye
Council Member Mario Buchanan Jr.	Aye
Council Member Africa Luna-Carrasco	Aye

Council Member Jose Ponce	Aye
Council Member Matias Rosales	Aye
Council Member Gloria Torres	Aye

C. Action on Conditional Use Permit Case No. 2019-067

MOTION: Council Member Africa Luna-Carrasco/Vice Mayor Maria Cecilia Ramos to approve the conditional use as presented. Motion passed unanimously.

The vote was as follows:

Mayor Gerardo Sanchez	Aye
Vice Mayor Maria Cecilia Ramos	Aye
Council Member Mario Buchanan Jr.	Aye
Council Member Africa Luna-Carrasco	Aye
Council Member Jose Ponce	Aye
Council Member Matias Rosales	Aye
Council Member Gloria Torres	Aye

6.G. Discussion and possible action on any and all matters regarding the proposal of an agreement contract between Automated Merchant Systems and the City of San Luis for credit and debit card merchant processing services. (Jorge Perez, Billing & Collections Manager and Jonathan Dumadag, Senior IT Technician)

Mr. Jorge Perez, Billing & Collections Manager, explained that this is a proposal contract agreement between the City of San Luis and Automated Merchant Systems who processes credit card payments for customers. The City of San Luis is currently accepting credit and debit card payments for all of its services (Utility, Permits, Licenses, Building Safety, etc.). However, payments are not being reflected in our billing software until the following business day. This occurs because the billing software and the online payment provider do not integrate/support each other. Due to this issue, staff must perform some manual entries to be able to post electronic payments into the billing software.

Staff has been exploring the possibility of working with a new merchant services provider that will allow them to take and post payments in real time into the billing software (Tyler - New World). By doing this, electronic payments will post automatically without manual entries diminishing the possibility of human error. The service would improve by increasing payment processing accuracy.

This new merchant services provider would also allow the City of San Luis to add other online services in the near future. Some of the new services/solutions to be provided to

the public include new card reader devices. These new card readers are highly secured to protect customer's personal information and credit/debit card integrity. They will also allow customers to use their credit card chip technology, ability to provide an electronic signature, and most importantly to make payments over the counter without having to hand out their credit/debit card to the customer service representative.

MOTION: Council Member Matias Rosales/Council Member Africa Luna-Carrasco to approve the agreements necessary to implement automatic posting to utility customer accounts of payments from on-line and debit cards. Motion passed unanimously.

The vote was as follows:

Mayor Gerardo Sanchez	Aye
Vice Mayor Maria Cecilia Ramos	Aye
Council Member Mario Buchanan Jr.	Aye
Council Member Africa Luna-Carrasco	Aye
Council Member Jose Ponce	Aye
Council Member Matias Rosales	Aye
Council Member Gloria Torres	Aye

6.H. Public hearing followed by discussion and possible action on any and all matters regarding recommendation of an Application for Extension of Premises/Patio Permit to the Arizona Department of Liquor Licenses and Control to authorize La Bodega Kitchen and Bar to sell alcohol on May 18, 2019 during the Dread Mar I Concert. (Ruben Walshe, La Bodega Kitchen and Bar)

A. Open public hearing

MOTION: Mario Buchanan Jr./Council Member Africa Luna-Carrasco to open the public hearing. Motion passed unanimously.

The vote was as follows:

Mayor Gerardo Sanchez	Aye
Vice Mayor Maria Cecilia Ramos	Aye
Council Member Mario Buchanan Jr.	Aye
Council Member Africa Luna-Carrasco	Aye
Council Member Jose Ponce	Aye
Council Member Matias Rosales	Aye
Council Member Gloria Torres	Aye

1. Staff / Applicant Presentation

Mr. Ruben Walshe, owner, stated that this is the first of a series of concerts programmed to be in San Luis this year. He explained the diagram attached to the agenda item review form and added that the event will begin at 6:00 p.m. The main artist is a reggae band from Argentina which will play at 10:00 p.m. It is expected to have 1200 attendees and the event will have security by a professional company.

MOTION:

The vote was as follows:

Mayor Gerardo Sanchez	Aye
Vice Mayor Maria Cecilia Ramos	Aye
Council Member Mario Buchanan Jr.	Aye
Council Member Africa Luna-Carrasco	Aye
Council Member Jose Ponce	Aye
Council Member Matias Rosales	Aye
Council Member Gloria Torres	Aye

2. Call to the public on this item

There were no comments from the public.

B. Close public hearing

MOTION: Council Member Africa Luna-Carrasco/Council Member Jose Ponce to close the public hearing. Motion passed unanimously.

The vote was as follows:

Mayor Gerardo Sanchez	Aye
Vice Mayor Maria Cecilia Ramos	Aye
Council Member Mario Buchanan Jr.	Aye
Council Member Africa Luna-Carrasco	Aye
Council Member Jose Ponce	Aye
Council Member Matias Rosales	Aye
Council Member Gloria Torres	Aye

C. Action on Application For Extension of Premises/Patio Permit to the Arizona Department of Liquor Licenses & Control

MOTION: Council Member Africa Luna-Carrasco/Council Member Jose Ponce to recommend approval to the Arizona Department of Liquor Licenses and Control the application for extension of premises/patio permit of La Bodega, LLC as presented. Motion passed with six aye votes and one nay vote by Vice Mayor Maria Cecilia Ramos.

The vote was as follows:

Mayor Gerardo Sanchez	Aye
Vice Mayor Maria Cecilia Ramos	Nay
Council Member Mario Buchanan Jr.	Aye
Council Member Africa Luna-Carrasco	Aye
Council Member Jose Ponce	Aye
Council Member Matias Rosales	Aye
Council Member Gloria Torres	Aye

6.I. Discussion and possible action on any and all matters regarding Resolution No. 2072. A resolution of the City of San Luis, Arizona, supporting the Proclamation of Emergency by the Mayor of the City of Yuma, Arizona. (Mayor Gerardo Sanchez)

Mayor Gerardo Sanchez stated that this is a proclamation supporting what the Mayor of Yuma did at the port of entry. This is something that has been occurring for months now at the port of entry and is controversial, there are those who are in favor of it or against, but there are children involved. The fact is, a broken system exists in immigration; over 300,000 people have crossed the borders in a period of two (2) months. The City of San Luis does not have the manpower nor the resources. The City of Yuma ran out of resources and there were over 340 families in centers of non-profit organizations like the Salvation Army, Catholic Community Services, Yuma Food Bank and Red Cross. There are 52 individuals including family and children that did not have a place to go to and ended up in San Luis at a catholic church and a transportation place. Some people do not think this is an emergency and that it will go away, they see it as a humanitarian crisis and people in D.C. want to build a 44 ft. wall and isolate themselves...there is an immigration problem that needs to be fixed. The laws allow for political asylum, local governments do not have the resources and don't have the answer. This is telling the federal and state government that the City of San Luis, City of Yuma nor the County of Yuma cannot fix the problem but are working together to help and will not close the doors and will not be silent.

Council Member Africa Luna-Carrasco stated that if everyone gets together, it can be accomplished.

MOTION: Mayor Gerardo Sanchez/Council Member Africa Luna-Carrasco to adopt Resolution No. 2072. Motion passed unanimously.

The vote was as follows:

Mayor Gerardo Sanchez	Aye
Vice Mayor Maria Cecilia Ramos	Aye
Council Member Mario Buchanan Jr.	Aye
Council Member Africa Luna-Carrasco	Aye
Council Member Jose Ponce	Aye
Council Member Matias Rosales	Aye
Council Member Gloria Torres	Aye

7. SUMMARY OF CURRENT EVENTS

Mayor Gerardo Sanchez reported he attended the NAFTA 2.0 which are in negotiations between the United States, Mexico and Canada. Country representatives from the three (3) nations were present and agreed that trade is important and he observed that the deficit between Mexico and Canada was discussed but not the deficit between China and the United States which is also significant. He added that Mexico is interested in continuing to invest in the United States.

Vice Mayor Maria Cecilia Ramos reported that she attended the South Yuma County Domestic Violence Coalition and the guest speaker was Estrella, CEO and founder of Lee's Journey and she provided a presentation on all the services they provide.

Council Member Matias Rosales reported he and others met Mr. Glenn Hamer from the Arizona Chamber of Commerce. He is the president and Chief Executive Officer for this organization and he and Ms. Katie Dauphinais got a tour of the city. He wanted to be a witness to the port of entry and wanted to get a visual impact and experience walking on foot and wait in line, as he supports the new port of entry funding being proposed by the federal government. Council Member Matias Rosales thanked him for visiting and his support.

Mayor Gerardo Sanchez added that last Wednesday a public demonstration and private session took place between the General Services Administration (GSA, Mayor Gerardo Sanchez and the Greater Yuma Port Authority (GYPA) and the port/funding was discussed. The governor mentioned in a speech that he supports the Port of Entry I, the \$248 million for this project and added that city officials should continue to attend those meetings.

Vice Mayor Maria Cecilia Ramos commented that not only does this benefit the region but it is greatly needed for the State of Arizona. San Luis Port of Entry is the only port in the presidential budget and it has a big impact.

She also invited everyone to attend the mother and son dinner dance on May 3, 2019. This event will help strengthen the relationship between mother and son.

Council Member Jose Ponce commented that the community will benefit from the approval of the \$248 million as more jobs would be created.

8. CALL TO THE PUBLIC

Ms. Maria Robles, 1195 California Street, San Luis, AZ, stated she is amazed by the work being done not only in San Luis but in the county. It is a pride to have this City Council that works really hard to generate changes that are needed in the community like the port of entry. She added that as a community member, she supports the projects that benefit the City of San Luis. She supports the special election, the City Council finally made that determination to have this election, this will directly benefit 100% the community. She congratulated the person who prepared the informational pamphlet as it is very simple and well explained as it details what it is and the benefit of the special election. She also mentioned that with the migrants' caravan, there are community members who respond when necessary like Buchanan's Transportation, a meeting will be held in Yuma tomorrow to discuss this situation in depth. She added that for the concert, Mr. Ruben Walsh hopefully asks for donations such as clothes, canned food, diapers, toothpaste, etc...for these people.

9. ADJOURNMENT

MOTION: Council Member Matias Rosales/Council Member Africa Luna-Carrasco to adjourn the Regular Council meeting at approximately 8:29 p.m. Motion passed unanimously.

The vote was as follows:

Mayor Gerardo Sanchez	Aye
Vice Mayor Maria Cecilia Ramos	Aye
Council Member Mario Buchanan Jr.	Aye
Council Member Africa Luna-Carrasco	Aye
Council Member Jose Ponce	Aye
Council Member Matias Rosales	Aye
Council Member Gloria Torres	Aye



AGENDA ITEM REVIEW FORM

Regular City Council Meeting

5.B.

Meeting Date: 05/22/2019

Summary

DISBURSEMENTS FROM APRIL 27, 2019 THROUGH MAY 10, 2019.

Total Disbursements \$587,710.99

(Five Hundred Eighty-Seven Thousand, Seven Hundred Ten Dollars and Ninety-Nine Cents)

Attachments

Disbursements 5-22-2019



City of San Luis

Finance Department

COUNCIL MEETING MAY 22, 2019 Disbursement Reports from 4/27/2019 to 5/10/2019

<u>Bank Accounts</u>	<u>Check Date</u>	<u>Amount</u>	<u>Schedule</u>
Payroll Check Account	4/30/2019	\$ 286,037.16	Schedule A
Accounts Payable Check Account	5/2/2019	\$ 101,804.71	Schedule B
Payroll Check Account	5/6/2019	\$ 4,506.39	Schedule C
Accounts Payable Check Account	5/9/2019	\$ 195,362.73	Schedule D

Total Disbursements: \$ 587,710.99

Please contact Ms. Monica Castro prior to the meeting if additional information is needed.

Prepared by Angelica V. Castro: _____

Verified by Director of Finance: _____

For Council approval on: _____

Mayor: _____

Council: _____

RECEIVED

2019 MAY 14 A 11: 21

CITY OF SAN LUIS
OFFICE OF THE CITY CLERK



Schedule A Pay Day Register

Pay Date Range 04/13/19 - 04/26/19

Pay Batch 201909

PSPRS POLICE DB RATE - TIER	3,121.58	26,794.78	BUS COMPANY AND DRIVERS	138.25	2,504.49
PSPRS POLICE DB RATE - TIER 2	892.60	7,661.80	CLERICAL OFFICE/ LIBRARY/	220.45	91,849.26
PSPRS POLICE DB RATE - TIER 3	1,424.57	14,331.74	Electrician	58.53	1,864.00
STANDARD LIFE ADDTNL	812.63	.00	FIREFIGHTERS & DRIVERS	2,513.27	71,399.06
TRANSWESTERN MEXICAN	96.26	.00	GARBAGE/ ASH/ REFUSE	265.59	4,249.44
U.S. MEX DENTAL - EE &	571.32	.00	MUNICIPAL/ TOWN/	67.97	3,884.00
U.S. MEX DENTAL - EE &	84.64	.00	PARKS- NOC ALL EMPLOYEES	524.53	16,919.86
UNITED WAY	14.00	.00	POLICE OFFICERS	4,165.74	95,107.86
US & MEX DENTAL= FAMILY	528.40	.00	RECREATION- ALL EMPLOYEES/	218.14	15,922.00
US & MEX HEALTH = C	5,992.00	.00	SEWAGE DISPOSAL/ PLANT	684.67	19,903.32
US & MEX HEALTH = FAMILY	4,353.85	.00	Street or Road Construction	1,297.01	16,151.96
US & MEX HEALTH = SP	898.80	.00	WATERWORKS OPERATIONS	562.24	16,202.48
VSP - VISION FAMILY	559.65	.00	Total	<u>\$12,030.53</u>	
Net	<u>\$286,037.16</u> ✓				

Direct Deposits	Amount
1st Bank Yuma	20,334.78
ACADEMY BANK	3,237.60
Bank of America	1,157.64
BBVA COMPASS	1,190.25
Charles Sch	200.00
Chase Bank	127,685.03
CHASE BANK CA	2,155.09
CHASE BANK MORGAN	1,607.18
chase centro	929.80
Federal Credit Union	37,144.64
FF CREDIT UNION	300.00
GREEN DOT BANK	1,346.19
National Bank	500.00
Navy Federal	10,079.90
NetSpend Corporation DD	120.00
NORTH ISLAND CREDIT UNION	1,052.84
Sunbank	1,427.37
USAA FEDERAL SAVING	1,079.38
WASHINGTON FEDERAL	940.04
Wells Fargo	54,818.38
WELLS FARGO ARKANSAS	1,382.68
Total	<u>\$268,688.79</u>

Check \$17,348.37

Prepared by:
Deborah Luna

Date:

Deborah Luna

Payment Register

From Payment Date: 4/29/2019 - To Payment Date: 5/2/2019

Number	Date	Status	Void Reason	Reconciled/ Voided Date	Source	Payee Name	Transaction Amount	Reconciled Amount	Difference
89228	05/02/2019	Open			Accounts Payable	REYNOSO, LINDA	\$90.00		
89229	05/02/2019	Open			Accounts Payable	SANFORD, JAMES	\$184.56		
89230	05/02/2019	Open			Accounts Payable	SIGN MASTERS	\$434.19		
89231	05/02/2019	Open			Accounts Payable	TORRES, CRISTIAN	\$420.00		
89232	05/02/2019	Open			Accounts Payable	TRACE ANALYTICS LLC	\$842.61		
89233	05/02/2019	Open			Accounts Payable	YUMA PRINTING & GRAPHIC DEPT.	\$108.85		
89234	05/02/2019	Open			Accounts Payable	YUMA WINLECTRIC CO.	\$4,445.29		
89235	05/02/2019	Open			Accounts Payable	YUMA WINNELSON CO.	\$5,598.18		
89236	05/02/2019	Open			Accounts Payable	ZATARAIN, EDUARDO	\$150.00		
							\$101,804.71		

Type Check Totals:
1BYPAYABLE - 1st BY Accounts Payable Totals

Checks	Status	Count	Transaction Amount	Reconciled Amount
	Open	93	\$101,804.71	\$0.00
	Reconciled	0	\$0.00	\$0.00
	Voided	0	\$0.00	\$0.00
	Stopped	0	\$0.00	\$0.00
	Total	93	\$101,804.71	\$0.00

All	Status	Count	Transaction Amount	Reconciled Amount
	Open	93	\$101,804.71	\$0.00
	Reconciled	0	\$0.00	\$0.00
	Voided	0	\$0.00	\$0.00
	Stopped	0	\$0.00	\$0.00
	Total	93	\$101,804.71	\$0.00

Grand Totals:

Checks	Status	Count	Transaction Amount	Reconciled Amount
	Open	93	\$101,804.71	\$0.00
	Reconciled	0	\$0.00	\$0.00
	Voided	0	\$0.00	\$0.00
	Stopped	0	\$0.00	\$0.00
	Total	93	\$101,804.71	\$0.00

All	Status	Count	Transaction Amount	Reconciled Amount
	Open	93	\$101,804.71	\$0.00
	Reconciled	0	\$0.00	\$0.00
	Voided	0	\$0.00	\$0.00
	Stopped	0	\$0.00	\$0.00
	Total	93	\$101,804.71	\$0.00

Prepared By:
Maggie Dominguez
Date: *Maggie D*
C 5/02/19

Payment Register

From Payment Date: 4/29/2019 - To Payment Date: 5/2/2019

Number	Date	Status	Void Reason	Reconciled/ Voided Date	Source	Payee Name	Transaction Amount	Reconciled Amount	Difference
1BYPAYABLE - 1st BY Accounts Payable									
Check									
89144	05/01/2019	Open			Accounts Payable	BALSINO, PETER, M	\$45.88		
89145	05/01/2019	Open			Accounts Payable	CALIFORNIA STATE DISBURSEMENT UNIT	\$252.91		
89146	05/01/2019	Open			Accounts Payable	CHARGO PA, GURSTEL	\$26.95		
89147	05/01/2019	Open			Accounts Payable	FOP/ALC	\$300.00		
89148	05/01/2019	Open			Accounts Payable	INTERNAL REVENUE SERVICE	\$100.00		
89149	05/01/2019	Open			Accounts Payable	SAN LUIS POLICE OFFICERS ASSOC	\$405.00		
89150	05/01/2019	Open			Accounts Payable	SUPPORT PAYMENT CLEARINGHOUSE	\$4,178.49		
89151	05/01/2019	Open			Accounts Payable	UNITED WAY OF YUMA COUNTY INC.	\$14.00		
89152	05/01/2019	Open			Accounts Payable	UNITED YUMA FIRE FIGHTERS ASSOC	\$75.50		
89153	05/01/2019	Open			Accounts Payable	UNITED YUMA FIRE FIGHTERS- IAFF	\$800.00		
89154	05/01/2019	Open			Accounts Payable	A & H ELECTRIC	\$580.00		
89155	05/01/2019	Open			Accounts Payable	ALONSO, FRANCIA	\$74.00		
89156	05/01/2019	Open			Accounts Payable	ALSCO, INC	\$620.38		
89157	05/01/2019	Open			Accounts Payable	ALVAREZ, MARIA , ELENA	\$1,695.00		
89158	05/01/2019	Open			Accounts Payable	ANGEL'S TOWING SERVICE/AUTO SALES	\$150.00		
89159	05/01/2019	Open			Accounts Payable	APPLIED PRODUCTS GROUP LLC	\$10,337.22		
89160	05/01/2019	Open			Accounts Payable	ARCTIC GLACIER USA INC	\$103.20		
89161	05/01/2019	Open			Accounts Payable	BORDER CONSTRUCTION SPECIALTIES	\$1,050.19		
89162	05/01/2019	Open			Accounts Payable	CARBAJAL, EDGAR	\$74.00		
89163	05/01/2019	Open			Accounts Payable	CARDENAS, JUAN, A	\$96.00		
89164	05/01/2019	Open			Accounts Payable	CARRILLO, JOHN, ROBERT	\$247.89		
89165	05/01/2019	Open			Accounts Payable	CENTURYLINK	\$1,327.81		
89166	05/01/2019	Open			Accounts Payable	CRAFICO INC.	\$196.75		
89167	05/01/2019	Open			Accounts Payable	CUEVAS, CHRISTIAN	\$100.00		
89168	05/01/2019	Open			Accounts Payable	DE LA HOYA, TADEO	\$74.00		
89169	05/01/2019	Open			Accounts Payable	DESERT VALLEY SERVICES, INC	\$295.83		
89170	05/01/2019	Open			Accounts Payable	DIVERSIFIED INSPECTIONS/ITL INC	\$1,580.00		
89171	05/01/2019	Open			Accounts Payable	ECHAVARRIA, NOHEMY	\$175.00		
89172	05/01/2019	Open			Accounts Payable	EMAZON, JESUS	\$240.00		
89173	05/01/2019	Open			Accounts Payable	FLORES SANDOVAL, CARLOS	\$140.34		
89174	05/01/2019	Open			Accounts Payable	FRANCO, MARTIN, A	\$344.00		
89175	05/01/2019	Open			Accounts Payable	FRED PRYOR SEMINARS	\$597.00		
89176	05/01/2019	Open			Accounts Payable	FRESH TERRA SERVICES LLC	\$1,305.00		
89177	05/01/2019	Open			Accounts Payable	G&T LOCKSMITH AND SAFE CO.	\$257.14		
89178	05/01/2019	Open			Accounts Payable	GARCIA, JESUS	\$300.00		
89179	05/01/2019	Open			Accounts Payable	GASTELUM, ADALBERTO	\$1,750.00		
89180	05/01/2019	Open			Accounts Payable	GUARDIAN MEDICAL PRODUCTS, LLC	\$2,236.80		
89181	05/01/2019	Open			Accounts Payable	GUEVARA, ALAN	\$59.00		
89182	05/01/2019	Open			Accounts Payable	GUZMAN, JOSE, A	\$74.00		
89183	05/01/2019	Open			Accounts Payable	GUZMAN COLIN, KARLA, P	\$750.00		

Payment Register

From Payment Date: 4/29/2019 - To Payment Date: 5/2/2019

Number	Date	Status	Void Reason	Reconciled/ Voided Date	Source	Payee Name	Transaction Amount	Reconciled Amount	Difference
89184	05/01/2019	Open			Accounts Payable	HERNANDEZ, IBETT	\$92.29		
89185	05/01/2019	Open			Accounts Payable	HUGHES FIRE EQUIPMENT, INC.	\$1,701.41		
89186	05/01/2019	Open			Accounts Payable	LARA, ISIDRO	\$308.00		
89187	05/01/2019	Open			Accounts Payable	LOPEZ RIOS, JOSE , A	\$336.00		
89188	05/01/2019	Open			Accounts Payable	LOPEZ, ENRIQUE	\$76.00		
89189	05/01/2019	Open			Accounts Payable	MCNEECE BROS. OIL COMPANY, INC	\$367.26		
89190	05/01/2019	Open			Accounts Payable	MEDINA, JOSE	\$110.00		
89191	05/01/2019	Open			Accounts Payable	METRO FIRE EQUIPMENT INC	\$541.00		
89192	05/01/2019	Open			Accounts Payable	NEW BORDER TACTICAL, INC.	\$1,381.94		
89193	05/01/2019	Open			Accounts Payable	PACIFIC MEDICAL WASTE	\$63.49		
89194	05/01/2019	Open			Accounts Payable	POLAR COOLING LLC	\$225.00		
89195	05/01/2019	Open			Accounts Payable	RAMIREZ, TERESITA, D	\$280.00		
89196	05/01/2019	Open			Accounts Payable	RAMIREZ MUNGUIA, ARTURO, I	\$351.00		
89197	05/01/2019	Open			Accounts Payable	RAMIREZ, ANGEL	\$76.00		
89198	05/01/2019	Open			Accounts Payable	SAMANIEGO, RODOLFO	\$6.15		
89199	05/01/2019	Open			Accounts Payable	SOUTH YUMA COUNTY LANDFILL	\$14,630.31		
89200	05/01/2019	Open			Accounts Payable	SOUTHWEST SANITATION SERVICES, LLC	\$99.00		
89201	05/01/2019	Open			Accounts Payable	SPECTRUM BUSINESS	\$5,336.70		
89202	05/01/2019	Open			Accounts Payable	SYNOVIA SOLUTIONS, LLC	\$456.14		
89203	05/01/2019	Open			Accounts Payable	TACOS EL CHIPILON, LLC	\$1,182.10		
89204	05/01/2019	Open			Accounts Payable	TORRES, ALEJANDRA , S	\$1,129.92		
89205	05/01/2019	Open			Accounts Payable	ULINE, INC.	\$1,923.61		
89206	05/01/2019	Open			Accounts Payable	VALENZUELA, GABRIEL, A	\$102.00		
89207	05/01/2019	Open			Accounts Payable	VERIZON WIRELESS MESSAGING SVC	\$1,600.42		
89208	05/01/2019	Open			Accounts Payable	VILLEGAS, LITZY	\$288.00		
89209	05/01/2019	Open			Accounts Payable	WAXIE SANITARY SUPPLY	\$649.15		
89210	05/01/2019	Open			Accounts Payable	YUMA OFFICE EQUIPMENT	\$151.76		
89211	05/01/2019	Open			Accounts Payable	YUMA REGIONAL MEDICAL CENTER	\$1,569.45		
89212	05/01/2019	Open			Accounts Payable	YUMA SUN INC	\$257.25		
89213	05/02/2019	Open			Accounts Payable	A & H ELECTRIC	\$260.00		
89214	05/02/2019	Open			Accounts Payable	ANIMAL CARE EQUIPMENT AND SERVICES	\$81.50		
89215	05/02/2019	Open			Accounts Payable	CDWG	\$800.84		
89216	05/02/2019	Open			Accounts Payable	ED M FELD EQUIPMENT CO. INC	\$345.00		
89217	05/02/2019	Open			Accounts Payable	GLOBAL EQUIPMENT COMPANY INC.	\$20.44		
89218	05/02/2019	Open			Accounts Payable	HACH COMPANY	\$3,000.00		
89219	05/02/2019	Open			Accounts Payable	HOLBROOK ASPHALT LLC	\$6,713.46		
89220	05/02/2019	Open			Accounts Payable	MARISCOS EL NAVEGANTE	\$1,421.50		
89221	05/02/2019	Open			Accounts Payable	MASTER AUTO GLASS LLC	\$232.46		
89222	05/02/2019	Open			Accounts Payable	MAYA'S CONSTRUCTION LLC.	\$1,118.00		
89223	05/02/2019	Open			Accounts Payable	NEWMAN TRAFFIC SIGNS	\$3,258.23		
89224	05/02/2019	Open			Accounts Payable	ON TRACK OVERHEAD DOORS	\$759.94		
89225	05/02/2019	Open			Accounts Payable	POLY'S PARTY RENTALS, LLC	\$2,518.00		
89226	05/02/2019	Open			Accounts Payable	PURCELL TIRE CO.	\$546.03		
89227	05/02/2019	Open			Accounts Payable	RAMON MOSQUEDA	\$135.00		



Schedule C
Pay Day Register
 Pay Date Range 05/01/19 - 05/31/19
 Pay Batch 201905M

Pay Batch 201905M Total

Employees in Pay Batch 7

Female Employees in Pay Batch 3

Hours Description	Hours	Gross	Withholdings and Deductions	Gross Base	Benefits	Gross Base
102 - SALARY	.0000	7,550.00	Gross	7,700.00	Dental Council	265.31 .00
806 - TELEPHONE STIPEND	.0000	150.00	Imputed Income		EODCRS - COUNCIL	108.00 .00
Total	0.0000	\$7,700.00	FEDERAL TAX WITHHOLDING	28.70 5,551.86	EODCRS - DISABILITY	2.26 .00
			SOCIAL SECURITY TAX	477.40 7,700.00	EODCRS/EORP LEGACY RATE	999.00 .00
			MEDICARE	111.63 7,700.00	Health Council	6,693.88 .00
			STATE WITHHOLDING	151.63 5,551.86	Retirement Council EORP	3,536.25 5,750.00
			Council Retirement EORP	588.50 5,750.00	Vision Council	74.90 .00
			Dental Council	147.98 .00	Total	\$11,679.60
			EODCRS - COUNCIL	144.00 .00	Workers' Comp	
			EODCRS - DISABILITY	2.26 .00	MUNICIPAL/ TOWN/	134.77 7,700.00
			GARNISHMENT	221.11 .00	Total	\$134.77
			Medical Council	1,216.20 .00	Direct Deposits	Amount
			MISCELLANEOUS	55.00 .00	1st Bank Yuma	728.71
			Vision Council	49.20 .00	Chase Bank	688.14
			Net	\$4,506.39	Federal Credit Union	918.38
					Sunbank	1,005.83
					WASHINGTON FEDERAL	751.40
					Wells Fargo	413.93
					Total	\$4,506.39
					Check	\$0.00

Prepared by:

Debora Luna

Date:

Payment Register

From Payment Date: 5/6/2019 - To Payment Date: 5/9/2019

Tr	Date	Status	Void Reason	Reconciled/ Voided Date	Source	Payee Name	Transaction Amount	Reconciled Amount	Difference
					Reconciled	0	\$0.00	\$0.00	
					Voided	1	\$100.00	\$0.00	
					Stopped	0	\$0.00	\$0.00	
					Total	101	\$195,362.73	\$0.00	
All									
					Status	Count	Transaction Amount	Reconciled Amount	
					Open	100	\$195,262.73	\$0.00	
					Reconciled	0	\$0.00	\$0.00	
					Voided	1	\$100.00	\$0.00	
					Stopped	0	\$0.00	\$0.00	
					Total	101	\$195,362.73	\$0.00	
Totals:									
Checks									
					Status	Count	Transaction Amount	Reconciled Amount	
					Open	100	\$195,262.73	\$0.00	
					Reconciled	0	\$0.00	\$0.00	
					Voided	1	\$100.00	\$0.00	
					Stopped	0	\$0.00	\$0.00	
					Total	101	\$195,362.73	\$0.00	
All									
					Status	Count	Transaction Amount	Reconciled Amount	
					Open	100	\$195,262.73	\$0.00	
					Reconciled	0	\$0.00	\$0.00	
					Voided	1	\$100.00	\$0.00	
					Stopped	0	\$0.00	\$0.00	
					Total	101	\$195,362.73	\$0.00	

Prepared By:
Maggie Dominguez
 Date: Maggie S.
 C 5/9/19

Payment Register

From Payment Date: 5/6/2019 - To Payment Date: 5/9/2019

Tr	Date	Status	Void Reason	Reconciled/ Voided Date	Source	Payee Name	Transaction Amount	Reconciled Amount	Difference
TABLE - 1st BY Accounts Payable									
	05/06/2019	Open			Accounts Payable	HOLYFIELD, MARC	\$673.40		
	05/06/2019	Open			Accounts Payable	LOPEZ, ENRIQUE	\$108.00		
	05/06/2019	Open			Accounts Payable	INTERNAL REVENUE SERVICE	\$221.11		
	05/06/2019	Open			Accounts Payable	SILVA, BLANCA	\$110.58		
	05/06/2019	Open			Accounts Payable	DUENAS, DEREK	\$76.00		
	05/06/2019	Open			Accounts Payable	ESPINOZA, ROGER	\$294.00		
	05/06/2019	Open			Accounts Payable	GUEVARA, ALAN	\$133.00		
	05/06/2019	Open			Accounts Payable	HEMMER, ADRIAN	\$209.00		
	05/06/2019	Open			Accounts Payable	JESSUP, RICHARD	\$76.00		
	05/06/2019	Open			Accounts Payable	OFFICE DEPOT	\$13,145.16		
	05/06/2019	Open			Accounts Payable	O'REILLY AUTO PARTS	\$4,045.07		
	05/07/2019	Open			Accounts Payable	SMITH, RALPH E. SR.	\$9,378.00		
	05/07/2019	Open			Utility Management	A&F HOME BUILDERS C/O G	\$1.90		
					Refund	FUENTES			
	05/07/2019	Open			Utility Management	ALVARADO, MARISOL	\$197.00		
					Refund				
	05/07/2019	Open			Utility Management	ANDRADE, GUSTAVO	\$87.83		
					Refund				
	05/07/2019	Open			Utility Management	BAEZ, SAMUEL, G	\$217.77		
					Refund				
	05/07/2019	Open			Utility Management	CASILLAS, RAFAEL	\$0.86		
					Refund				
	05/07/2019	Open			Utility Management	CASTILLO, ELIZABETH &	\$14.44		
					Refund	ANACLETO HERNANDEZ			
	05/07/2019	Open			Utility Management	COMITE DE BIENESTAR INC	\$28.25		
					Refund				
	05/07/2019	Open			Utility Management	COMITE DE BIENESTAR INC	\$17.67		
					Refund				
	05/07/2019	Open			Utility Management	CUEVAS, IRMA, A	\$10.81		
					Refund				
	05/07/2019	Open			Utility Management	DENNY'S INC	\$605.34		
					Refund				
	05/07/2019	Open			Utility Management	DENNY'S INC	\$638.50		
					Refund				
	05/07/2019	Open			Utility Management	F P STORES	\$384.06		
					Refund				
	05/07/2019	Open			Utility Management	FLORES, ANIBAL & AURORA G	\$159.65		
					Refund				
	05/07/2019	Open			Utility Management	GUTIERREZ, MARIA G & DANIELA	\$96.25		
					Refund				
	05/07/2019	Open			Utility Management	HOREB PROPERTIES LLC/SELMA	\$176.06		
					Refund	MARTINEZ			
	05/07/2019	Open			Utility Management	LOPEZ, GUADALUPE & JULIO	\$37.27		
					Refund				
	05/07/2019	Open			Utility Management	MEDINA, JAVIER & RODRIGUEZ,	\$168.56		
					Refund	ELIZABETH			
	05/07/2019	Open			Utility Management	MENDEZ, ANTONIA	\$29.11		
					Refund				

Payment Register

From Payment Date: 5/6/2019 - To Payment Date: 5/9/2019

Date	Status	Void Reason	Reconciled/ Voided Date	Source	Payee Name	Transaction Amount	Reconciled Amount	Difference
05/07/2019	Open			Utility Management Refund	MENDEZ, JOEL	\$59.92		
05/07/2019	Open			Utility Management Refund	PINEDA CAMACHO JAVIER & JOSEFINA CAMACHO	\$15.20		
05/07/2019	Open			Utility Management Refund	RASCON HERNANDEZ, NIDIA, C	\$33.00		
05/07/2019	Open			Utility Management Refund	RIOS, YOLANDA	\$33.80		
05/07/2019	Open			Utility Management Refund	RODRIGUEZ, IDUBINA	\$74.46		
05/07/2019	Open			Utility Management Refund	RODRIGUEZ, ROSA	\$183.22		
05/07/2019	Open			Utility Management Refund	ROJAS, RAUL	\$3.46		
05/07/2019	Open			Utility Management Refund	SOTELO, JAVIER & IRIS A. RUIZ	\$134.60		
05/07/2019	Open			Utility Management Refund	VALENCIA, ARACELI	\$157.21		
05/07/2019	Open			Utility Management Refund	VELASCO, JORGE/TLC CUSTOM FARMING	\$1,024.40		
05/07/2019	Open			Utility Management Refund	ZAMUDIO, JAZMIN	\$140.07		
05/09/2019	Open			Accounts Payable	BELTRAN, ERNESTINA	\$1,800.00		
05/09/2019	Open			Accounts Payable	CLARK, ANTHONY	\$100.00		
05/09/2019	Open			Accounts Payable	CORONADO, JAVIER	\$30.00		
05/09/2019	Open			Accounts Payable	CUEVAS, CHRISTIAN	\$187.50		
05/09/2019	Open			Accounts Payable	GARCIA, JESUS	\$650.00		
05/09/2019	Open			Accounts Payable	GOMEZ-DOMINGUEZ, FRANCISCO	\$1,963.86		
05/09/2019	Voided		05/09/2019	Accounts Payable	HERRERA, ROSA, A	\$100.00		
05/09/2019	Open			Accounts Payable	LA PEQUENA	\$1,320.00		
05/09/2019	Open			Accounts Payable	MACHADO, IVAN & AIXIA GUTIERREZ	\$1,300.00		
05/09/2019	Open			Accounts Payable	NAVARRO, CAROLINE	\$200.00		
05/09/2019	Open			Accounts Payable	NIEVES HEIDY QUINTERO	\$900.00		
05/09/2019	Open			Accounts Payable	PETTY CASH/POLICE	\$183.06		
05/09/2019	Open			Accounts Payable	RAMIREZ, LUIS, E	\$1,500.00		
05/09/2019	Open			Accounts Payable	RODRIGUEZ, RIGOBERTO	\$150.00		
05/09/2019	Open			Accounts Payable	HERRERA, ROSANGELA	\$100.00		
05/09/2019	Open			Accounts Payable	ALSCO, INC	\$555.01		
05/09/2019	Open			Accounts Payable	ARIZONA BRAKE & CLUTCH SUPPLY	\$52.13		
05/09/2019	Open			Accounts Payable	ARIZONA MUNICIPAL CLERK'S ASSOCIATION	\$320.00		
05/09/2019	Open			Accounts Payable	ARIZONA POLICE PSYCHOLOGY, PLLC	\$300.00		
05/09/2019	Open			Accounts Payable	ARIZONA PROSECUTING ATTORNEY'S ADVISORY COUNCIL	\$100.00		
05/09/2019	Open			Accounts Payable	ARIZONA SOUTHWEST UNIFORMS LLC	\$159.48		
05/09/2019	Open			Accounts Payable	AUTOZONE STORES, INC	\$10,621.43		



AGENDA ITEM REVIEW FORM

Regular City Council Meeting

6.A.

Meeting Date: 05/22/2019

Department Head: Kay Macuil, City Attorney, Attorney's Office

Submitted By: Kay Macuil, City Attorney, Attorney's Office

Action Requested: Motion
Resolution

ITEM:

Discussion and possible action on any and all matters regarding Resolution No. 2074. A resolution of the Mayor and City Council of the City of San Luis, Arizona directing the City Manager to establish and implement a plan for the fiscal year 2019-2020 for reduction in force and in civic contributions to ensure that city expenses do not exceed city revenues; superseding any conflicting provisions of the city; and providing for severability; and declaring an emergency. **(Tadeo A. De La Hoya, City Manager)**

SUMMARY:

City Council held its annual budget workshops on April 26 and 27, 2019 and on May 15, 2019. The proposed 2019-2020 budget showed a deficit. The attached resolution directs the City Manager to implement a plan for a reduction in force and expenditures in community contributions to balance the fiscal year 2019-2020 budget.

In anticipation of a significant shortfall in anticipated revenues, and to ensure that City expenses do not exceed revenues, this resolution authorizes the City Manager to establish and implement a plan in line with the city's Personnel Policy on reduction in force (attached). The resolution amends the 2017 Classification Plan and the 2018 Salary Plan to implement the following changes as the manager deems necessary:

- layoff or grant furlough (leave without pay) up to ten (10) full-time positions,
- transfer and merge up to five (5) positions,
- reduce, suspend, or eliminate overtime in all city departments (except overtime paid by federal or state grants) and
- suspend salary adjustment increases.

The plan will also allow the City Manager to reduce expenditures on civic community contributions.

The city has adopted similar resolutions in past years at least four (4) times. The prior resolutions are attached.

The measures that were taken to implement the salary plan for the 2018-2019 fiscal year shall continue into the 2019-2020 fiscal year. City Council adopted those measures on July 9, 2018, in Resolution No. 2015-A (attached).

Under the Resolution, City Council reserves its right to make more decisions regarding the plan, including ending the plan.

RECOMMENDATION / SUGGESTED MOTION:

I MOVE TO APPROVE AND ADOPT RESOLUTION NO. 2074 AND DECLARE AN EMERGENCY.

N/A

Fiscal Impact

IS THERE FISCAL IMPACT ASSOCIATED WITH THIS ITEM: N/A
CITY/STATE/FEDERAL FUNDS: N/A
TOTAL: N/A
BUDGETED AMOUNT: N/A
AVAILABLE AMOUNT TO TRANSFER: N/A
ACCT NAME & GL#/REMAINING BALANCE BEFORE PURCHASE: N/A

FISCAL IMPACT STATEMENT (IF THIS IS A BUDGET TRANSFER, YOU MUST ATTACH THE BUDGET ADJUSTMENT FORM):

There is no fixed amount associated with this item. This item authorizes a plan to allow the City Manager to reduce expenses of the city within certain limitations in order to balance the 2019-2020 fiscal year budget.

Attachments

Resolution No. 2074
HR-8-03 Reduction in Force Policy
City Code Manager's Powers
Resolution No. 2051-A
Resolution No. 917
Resolution No. 1006
Resolution No. 1052
Resolution No. 1148



Resolution

OFFICE OF THE
MAYOR
CITY OF SAN LUIS

No. 2074

A RESOLUTION OF THE MAYOR AND CITY COUNCIL OF THE CITY OF SAN LUIS, ARIZONA DIRECTING THE CITY MANAGER TO ESTABLISH AND IMPLEMENT A PLAN FOR THE FISCAL YEAR 2019-2020 FOR REDUCTION IN FORCE AND IN CIVIC CONTRIBUTIONS TO ENSURE THAT CITY EXPENSES DO NOT EXCEED CITY REVENUES; SUPERSEDING ANY CONFLICTING PROVISIONS OF THE CITY; AND PROVIDING FOR SEVERABILITY; AND DECLARING AN EMERGENCY.

WHEREAS, the City of San Luis has experienced a significant shortfall in anticipated revenues for the fiscal year 2019-2020;

WHEREAS, A.R.S. §42-17110 requires incorporated cities and towns, by the third Monday in July of each year to prepare a full and complete statement of the city's financial affairs for the preceding fiscal year and an estimate of the different amounts required to meet the city's public expense for the current fiscal year;

WHEREAS, the Finance Director has scheduled bringing the final adoption of the budget to City Council on June 26, 2019;

WHEREAS, A.R.S. §42-17105 requires that the City Council adopt proposed estimates of revenues and expenses as the budget for the current fiscal year and the amounts proposed to be spent shall not exceed the amounts proposed in the estimates;

WHEREAS, A.R.S. §42-17106 places limitations on expenditures and limits expenditures to budgeted purposes;

WHEREAS, the city has expected expenditures that may exceed revenues before the end of the 2019-2020 fiscal year;

WHEREAS, it is the intent of this resolution to provide for the most efficient delivery of service to the residents of the City of San Luis, and to maintain sound financial structure for the city in its operations and infrastructure;

WHEREAS, it has been determined that certain changes to the city's operations and or restructuring of the delivery of services is necessary during the 2019-2020 fiscal year to

fulfill the intent of this resolution;

THEREFORE, BE IT RESOLVED by the Mayor and City Council of the City of San Luis, Arizona:

Section 1. The City Manager is directed and authorized to establish and implement a plan under Section HR-8-03 on Reduction of Force of the City of San Luis Personnel Policies dated July 1, 2008, and to reduce civic contribution expenditures under his administrative powers under San Luis City Code Section 31.01 and Chapter 36 Purchasing.

Section 2. The plan shall be limited to the following changes to the Classification Plan (Resolution No. 1196) and Salary Plan (Resolution No. 2051-A) as the City Manager deems necessary:

- a) layoff or grant furlough (leave without pay) for up to ten (10) full-time positions,
- b) transfer and merge up to five (5) positions (resulting in up to five (5) additional layoffs),
- c) reduce, suspend, or eliminate overtime in all city departments (except overtime paid by federal or state grants) and
- d) suspend salary adjustment increases.

The total laid-off, furloughed or transferred and merged positions shall not exceed a total of 15 positions. The City Manager's authority under this plan includes the power to reassign duties (including supervisory duties) to remaining positions to provide for continuity of service. The Classification Plan and Salary Plan are amended to conform to this plan. The positions subject to layoff, transfer and merging are not being eliminated nor is this action to be considered an action of discipline, but rather this action is being taken solely as a budget measure to ensure that shortfalls in the expected revenues for the fiscal year 2019-2020 do not jeopardize the financial condition of the city.

Section 3. The measures to implement the Salary Plan under Resolution No. 2015-A of July 9, 2018, shall continue for the salary allocations for the 2019-2020 fiscal year.

Section 4 Under this plan, the City Manager may counsel with employees who may wish to seek early retirement or otherwise leave the city service and negotiate such retirements or resignations as deemed appropriate.

Section 5. The City Manager is directed to make recommended reductions to reduce civic contributions consistent with ensuring that expenditures do not exceed revenues and that the goals of efficient delivery of service and maintenance of infrastructure are met. The City Manager shall recommend contracts to Council consistent with the intent of this resolution.

Section 6. The plan shall begin when it is implemented by the City Manager and will last until the further decision of the City Council. City Council reserves the right to make further decisions regarding the plan as part of planning and policy adjustments for the fiscal year 2019-2020.

Section 7. The measures to implement the salary Plan to the extent possible under the 2018-2019 salary allocation under Resolution 2051-A shall continue into the 2019-2020 fiscal year.

Section 8. If a conflict arises between this resolution and any other resolution, ordinance, order, regulation or policy of the City of San Luis, the conflicting provisions of this resolution shall govern. In making this provision, it is the specific legislative intent of the City Council that the City of San Luis Personnel Policies, Classification Plan and Salary Plan, as well as the salary administration regulations and policies of the City of San Luis, are amended, superseded and/or replaced by this resolution so actions and the plan authorized by this resolution may be implemented, and this is a non-appealable final legislative decision and action of the City Council of the City of San Luis.

Section 9. If any section, subsection, sentence, clause, phrase, or portion of this resolution is held to be invalid or unconstitutional by the final decision of a court of competent jurisdiction, such decision shall not affect the validity of the remaining portions of this resolution.

Section 10. It is necessary for the preservation of the peace, health, safety and welfare of the City of San Luis, Arizona, and for further reason that municipal services to the citizens of the City of San Luis may be provided in the most efficient manner possible without interruption in service, as well as the financial consideration of the immediate need to ensure that expenditures do not exceed available funds for the fiscal year 2019-2020, and that the best interests of the city require this resolution shall become immediately operative and in force and effect after posting of this resolution.

PASSED, ADOPTED and APPROVED by the Mayor and City Council of the City of San Luis, Yuma County, Arizona this ____ day of May 2019

Gerardo Sanchez, Mayor

ATTEST:

Sonia Cornelio, City Clerk

APPROVED AS TO FORM:

Kay Marion Macuil

Kay Marion Macuil, City Attorney

HR-8-03. Reduction in Force.

A. General. Reduction in force shall follow fair labor practices and comply with all applicable anti-discrimination laws.

B. When possible, temporary, seasonal, limited and original probationary employees shall be selected for reduction in force over regular status employees.

C. The City Administrator shall establish guidelines for a reduction in force when this policy does not specify the procedure, which may include but are not limited to reassignment of positions, transfer, and offering a lower pay grade to a regular status employee. The City Administrator shall instruct Human Resources Director to carry out the reduction in force.

D. Employee request for review. A regular-status employee who receives a reduction in force notice resulting in the employee's transfer, reduction of wages, or separation due to a reduction in force may request a written review within 3 days of the notice. The request for review shall be based upon an error, contain specific information concerning the error involved, and include a proposed resolution of the problem. Human Resources shall review the request and respond to the employee within 5 working days after receipt of the request.

E. There is no grievance or appeal right for reduction in force actions.

§ 31.20 CITY MANAGER.

(A) (1) *Office created.* The office of the City Manager is hereby created and established. The City Manager shall be appointed by the Council wholly on the basis of his or her administrative and executive ability and qualifications, and shall hold office for, and at the pleasure of, the Council.

(2) *Bond.* The City Manager shall furnish a corporate surety bond to be approved by the Council in the sum as may be determined by the Council, and shall be conditioned upon the faithful performance of the duties imposed upon the Manager as herein prescribed. Any premium for the bond shall be a proper charge against the city.

(3) *Compensation.* The City Manager shall receive compensation as the Council shall fix from time to time.

(4) *Removal procedure.* The Manager may be removed according to § 31.25. If requested, the Council shall grant him or her a public hearing within 30 days following notice of removal. During the interim, the Council may suspend the Manager from duty, but shall continue his or her salary and, if the removal becomes final, shall pay his or her salary for one month following the removal date.

(5) *Powers and duties.* The City Manager shall be the administrative head of the government of the city under the direction and control of the Council except as otherwise provided in this chapter. He or she shall be responsible to the Council for the proper administration of all affairs of the city. In addition to his or her general powers as administrative head, and not a limitation thereon, it shall be his or her duty and he or she shall have the powers set forth in the following divisions (A)(5)(a) through (m) below:

(a) Appoint and, when necessary for the good of the city service, suspend or remove all officers and employees of the city not appointed by the Council. He or she may authorize the head of a department or office to appoint, suspend or remove subordinates in the department or office;

(b) Prepare the budget annually and submit it to the Council together with a message describing the important features, and be responsible for its administration after adoption;

(c) Prepare and submit to the Council, at the end of the fiscal year, a complete report on the finances and administrative activities of the city for the preceding year;

(d) Keep the Council advised of the financial condition and future needs of the city and make recommendations as he or she may deem desirable;

(e) Recommend to the Council a standard schedule of pay for each appointive office and position in the city service, including minimum, intermediate and maximum rates, and authorize the payment of overtime pay for employees as may work in excess of normal work period. The rates of pay and period of work shall be in conformity with wages and salaries enacted by the City Council;

(f) Recommend to the City Council from time to time adoption of measures as he or she may deem necessary or expedient for the health, safety or welfare of the community, or for the improvement of administrative services;

(g) Consolidate or combine offices, positions, departments or units under his or her jurisdiction, with the approval of the Council. The Manager may be the head of one or more departments;

(h) Attend all meetings of the Council unless excused therefrom, and take part in the discussion of all matters coming before the Council. He or she shall be entitled to give notice of all regular and special meetings of the Council;

(i) Supervise the purchase of all materials, supplies, and equipment for which funds are provided in the budget; let contracts necessary for operation or maintenance of city services in accordance with the purchasing provisions of the City Code; receive sealed bids for purchase or contracts in accordance and present them to Council for approval in accordance with the purchasing provisions of the City Code or state or federal law, and advise the City Council on the advantages or disadvantages of contract or bid proposals. The Manager may issue rules governing purchasing procedures within the administrative organization as Council shall approve.

(j) In the case of accident, disaster or other circumstances creating a public emergency, the Manager may award contracts and make purchases for the purpose of meeting the emergency, but he or she shall file promptly with the Council a certificate showing the emergency and the necessity for the action, together with an itemized account of all expenditures;

(k) See that all laws and ordinances are duly enforced;

(l) Investigate the affairs of the city or any department or division thereof, investigate all complaints in relation to matters

concerning the administration of the government of the city, and in regard to service maintained by the public utilities in the city and see that all franchises, permits and privileges granted by the city are faithfully observed; and

(m) Perform other duties as may be required by the Council, not inconsistent with state law or city ordinances.

(B) With regard to officers and employees appointed by the Manager, neither the Council nor any of its members shall direct or request the appointment of any person to, or his or her removal or suspension from, the office by the Manager or any of his or her subordinates, or in any manner take part in the appointment or removal of the officers and employees in the administrative services of the city, except for the purpose of inquiry, the Council and its members shall deal solely through the Manager.

(Prior Code, § 3-2-1) (Ord. 331, passed 11-12-2014)



WHEN RECORDED MAIL TO:

**CITY OF SAN LUIS
ATTN: CITY CLERK
P.O. BOX 1170
SAN LUIS, ARIZONA 85349**

The above area is to be reserved for recording information

CAPTION HEADING:

Resolution No. 2051-A

Declaring public records; adopting a Salary Plan; directing staff to implement the Salary Plan within 2018-2019 salary allocation; declaring an emergency



Resolution

OFFICE OF THE
MAYOR
CITY OF SAN LUIS

No. 2051-A

A RESOLUTION OF THE MAYOR AND CITY COUNCIL OF THE CITY OF SAN LUIS, ARIZONA, DECLARING PUBLIC RECORDS; ADOPTING A SALARY PLAN; DIRECTING STAFF TO IMPLEMENT THE SALARY PLAN WITHIN THE 2018-2019 SALARY ALLOCATION; SUPERSEDING ANY CONFLICTING PROVISIONS OF EXISTING REGULATIONS, POLICIES OR PROCEDURES; PROVIDING FOR SEVERABILITY; DECLARING AN EMERGENCY; AND ESTABLISHING AN EFFECTIVE DATE.

WHEREAS, the legal authority to adopt a salary plan derives from A.R.S. § 9-303, the San Luis City Code §31.20(5)(e) and Resolution No. 750, Personnel Policies of 2008, §HR3-02(A).

WHEREAS, the City of San Luis is in need of a new salary plan because the city has been experiencing turn over in many of its positions often due to lower than market salaries and the current Salary Plan has not been addressed as a whole since 2006;

WHEREAS, City Council prioritized salaries and benefits in the 2018-2019 budget including opting to have the City pay the health benefit increases rather than burden the employees with health benefits increases.

WHEREAS, the studies for the basis of this Salary Plan are the "Classification Study and Final Report" by CPS HR Consulting adopted by Resolution No. 1196 on June 7, 2017 (referred to as "Classification Study") and "City of San Luis, Arizona Total Compensation Report" by CPS HR Consulting of July 3, 2018 (referred to as "Compensation Report") which together serve as guides to the region's market for salaries and benefits for the classified service of the City of San Luis;

WHEREAS, the city has legal and practical budgetary constraints in its ability to spend on salaries and benefits including but not limited to:

1. the city's duty to spend on public purposes in providing services to the residents of San Luis,

2. Some of the city's revenue is restricted to purposes such as state Highway Users Revenue Fund for roads and Development Fees for statutory purposes related to the impacts of development,
3. Arizona Constitution Article IX §20 and A.R.S. §42-17106 place limitations on city expenditures and
4. A.R.S. Title 42, Chapter 17, Article 3 requires cities to have a balanced budget every year so that expenses do not exceed available revenues.

WHEREAS, there are insufficient funds to implement this Salary Plan during the 2018-2019 fiscal year;

WHEREAS, staff analyzed each position to allocate the available funds for the approximately 277 positions;

WHEREAS, City Council finds that it is necessary to implement only partially the Salary Plan the fiscal year 2018-2019;

WHEREAS, City Council finds that additional steps are necessary to allocate the available funds fairly because there will be increases in salary and benefits based on the Salary Plan other increases under the Personnel Policy or by administrative practice are suspended in this resolution.

WHEREAS, City Council plans to fund this Salary Plan incrementally every year over a period of four years.

THEREFORE BE IT RESOLVED by the Mayor and Council of the City of San Luis:

Declaring Public Records

Section 1. The documents entitled:

- a. Classification Study and Final Report approved by Resolution No. 1196 ("Classification Study" Exhibit A),
- b. City of San Luis, Arizona Total Compensation Report ("Compensation Report" Exhibit B),
- c. 2018-2019 Salary Allocations (Exhibit C),
- d. Skill Pay Schedule (Exhibit D),
- e. Salary Classifications and Pay Grade (Exhibit E),

f. Salary Classifications and Pay Grade for the Safety Group (Exhibit F) and

g. Salary Pay Grade Schedule (Exhibit G),

three (3) copies of which are on file in the Office of the City Clerk of the City of San Luis, Arizona, are declared to be public records; and the copies shall remain on file with the City Clerk's office and shall be available for public examination and reproduction upon request.

Adoption of Salary Plan and Related Documents Adopted

Section 2. The City Council approves and adopts as guides and basis for the 2018 Salary Plan adopted by this resolution:

- a. the Classification Study and Final Report approved by Resolution No. 1196 ("Classification Study" Exhibit A) and
- b. the City of San Luis, Arizona Total Compensation Report ("Compensation Report" Exhibit B)

Section 3. City Council amends the 2006 Salary Plan to comport with the changes made by this resolution.

Section 4. City Council approves and adopts the 2018 Salary Plan which consists of:

- a. the Skill Pay Schedule (Exhibit D),
- b. the Salary Classifications and Pay Grade (Exhibit E),
- c. the Salary Classifications and Pay Grade for the Safety Group (Exhibit F),
- d. the Salary Pay Grade Schedule (Exhibit G), and
- e. this resolution.

Section 5. To stay within legal expenditure limits as passed in the 2018-2019 fiscal year budget Resolution No. 2046, City Council approves and adopts the 2018-2019 Salary Allocations (Exhibit C).

Section 6. The Salary Plan and the measures below for the fiscal year 2018-2019 apply to the classified service and amends the contracts of contracted employees. As to contracted employee, any adjustments made by the implementation of the Salary Plan shall be considered a "cost of living" adjustment to compensation.

///

**Measures to Implement the Salary Plan to Extent Possible
under the 2018-2019 Salary Allocation**

Section 7. City Council directs staff to take all steps to implement the Salary Plan within the 2018-2019 Salary Allocations in Exhibit (C).

Section 8. City Council directs that staff apply the pay schedule for years in the position and not years of service.

Section 9. City Council directs that staff stay within the 2018-2019 Allocation of Salary Summary calculation in paying any state or federal minimum salaries increases during the fiscal year 2018-2019.

Section 10. City Council suspends all increases under Resolution 570, Personnel Policies of 2008 except Skills Pay (§ HR3-02(B)(1) and except the City Manager may correct inequities upon the promotion of an employee (§ HR3-03(B)(2)).

Section 11. City Council suspends the practice of increases for successful completion of probation for those employees who begin probation on or after the effective date of this resolution.

Section 12. The vacation buy back program is a program contingent on availability of funds. City Council reduces the vacation buy back program from 40 hours of unused vacation pay to 20 hours of unused vacation pending further decision of City Council.

**Providing for Severability, Superseding Conflicting Provisions,
Declaring an Emergency; and Establishing an Effective Date**

Section 13. If any section, subsection, sentence, clause phrase, or a portion of this resolution is held to be invalid or unconstitutional by the final decision of any court of competent jurisdiction, such decision shall not affect the validity of the remaining portions of this resolution.

Section 14. If a conflict arises between the provisions of this resolution and any other ordinance, resolution, regulation, or policy of the City of San Luis, the conflicting provisions are amended, superseded, and replaced, and this resolution shall govern. It is the specific legislative intent of the City of San Luis, that the 2018 Salary Plan and the salary administration regulations, policies and plans of the City of San Luis are amended, superseded so the actions and plans authorized by this resolution may be implemented. This resolution is a non-appealable final legislative decision and action of the City Council of the City of San Luis.

Section 15. To maintain stable operations and sound financial structure of the City of San Luis; it is necessary for the preservation of the peace, health and safety of the City

of San Luis, Arizona, an emergency is declared to exist, and this resolution shall become immediately operative and in force from and after August 4, 2018.

Section 16. This resolution shall become operative and in force and effect on and after August 4, 2018.

Section 17. This resolution shall be posted immediately upon passage.

Section 18. The appropriate City officials are authorized and directed to take any actions as may be necessary to effectuate this resolution.

PASSED, APPROVED and ADOPTED by the Mayor and City Council of the City of San Luis, Yuma County, Arizona this 9th day of July 2018.



Gerardo Sanchez, Mayor

ATTEST:



Sonia Cornelio, City Clerk

APPROVED AS TO FORM:



Kay Marion Macuil, City Attorney



Resolution

RESOLUTION NO. 917

OFFICE OF THE
MAYOR
CITY OF SAN LUIS

A RESOLUTION OF THE MAYOR AND COUNCIL OF THE CITY OF SAN LUIS DIRECTING THE CITY MANAGER TO ESTABLISH AND IMPLEMENT GUIDELINES AND A PLAN FOR REDUCTION IN FORCE PURSUANT TO PERSONNEL POLICIES; AUTHORIZING AND DIRECTING A PLAN FOR LAYOFFS AND CONVERSION OF POSITIONS WITHIN THE CLASSIFIED SERVICE N OF THE CITY; TO AUTHORIZE THE TAKING OF SUCH OTHER ACTS AND ACTIONS AS MAY BE NEEDED AND/OR NECESSARY TO ENSURE THAT CITY EXPENSES DO NOT EXCEED CITY REVENUES; SUPERSEDING ANY CONFLICTING PROVISIONS OF EXISTING REGULATIONS, POLICIES OR PROCEDURES; PROVIDING FOR SEVERABILITY; AND DECLARING AN EMERGENCY

Whereas the City of San Luis has experienced a significant shortfall in anticipated revenues for fiscal year 2010/2011, that the performance measures as of the end of November, 2010 show shortfalls of \$976,000 in the General Revenue Fund, \$9,500 in the Highway User Fund, \$108,000 in the Water Utility Fund, and \$377,000 in the Wastewater Utility Fund;

Whereas A.R.S. §42-17101 requires incorporated cities and towns, on or before the third Monday in July of each year to prepare a full and complete statement of political subdivision's financial affairs for the preceding fiscal year and an estimate of the different amounts required to meet the political subdivision's public expense for the current fiscal year and A.R.S. §42-17105 provides that the governing body of a municipality must adopt estimates of proposed estimates of revenues and expenses as the budget for the current fiscal year and the amounts proposed to be spent shall not exceed the amounts proposed in the estimates;

Whereas A.R.S. §42-17106 places limitations on expenditures and limits expenditures to budgeted purposes;

Whereas the City has experienced expenditures in several departments which are either exceeding estimates or are likely to exceed estimates before the end of the fiscal year, particularly in expenditures for overtime;

Whereas in order to provide for the most efficient delivery of service to the citizens of the City of San Luis, and to maintain sound financial structure for the city in its finances and operations; it has been determined that certain changes to the operations of the City of San Luis and a restructuring of the delivery of services has become immediately necessary;

NOW, THEREFORE, BE IT RESOLVED BY THE MAYOR AND CITY COUNCIL OF THE CITY OF SAN LUIS:

Section 1: The City Manager is hereby directed and authorized to prepare and implement guidelines and a plan pursuant to Section 8.03 of the City of San Luis Personnel Policies, dated July 1, 2008, to layoff positions of up to fifteen (15) full time positions within the Classification and Salary Plan of the City of San Luis and to convert up to five (5) full time positions to part time positions, with the understanding that the total of laid off or converted positions shall not exceed a total of twenty (20) positions. The Classification and Salary Plan is hereby amended to conform to said plan. The positions that will be subject to layoff and conversion are not being eliminated nor is this action to be considered an action of discipline, but rather this action is being taken solely as a budget measure in order to ensure that shortfalls in expected revenues for fiscal year 2010/2011 do not jeopardize the financial condition of the city. The period of layoff and conversion shall begin at such time as the plan is implemented by the City Manager and will last until further decision of the City Council. City Council, by this resolution, specifically reserves the right to make further decisions with respect to these positions as part of planning for fiscal year 2011/2012.

Section 2: The City Manager is hereby authorized and directed to take such steps as may be needed or necessary to reduce, suspend, or eliminate the accrual of overtime in all city departments, with the exception of overtime as actually paid by federal or state grants. It is the legislative intent of the City Council to specifically disallow regular paid overtime until July 1, 2011.

Section 3: The City Manager is hereby authorized and directed to implement a plan for eight (8) hours a month unpaid furlough time for all employees, other than certified fire personnel, in the Classified service of the City beginning March 1, 2011 and ending June 30, 2011. For certified fire personnel the City Manager is hereby authorized and directed to implement a plan for ten and six-tenths (10.6) hours a month unpaid furlough time beginning March 1, 2011 and ending June 30, 2011. The Classification and Salary Plan of the City of San Luis is hereby amended accordingly to conform to such plan or plans. By this resolution the City Manager is hereby directed to seek, prepare, and execute appropriate contract amendments from all employees who are either not in Classified service or who otherwise have employment contracts with the

City so that they will incur eight (8) hours a month unpaid furlough time beginning March 1, 2011 and ending June 30, 2011. With respect to the contract with the City Manager, the Mayor is authorized to execute such an amendment.

Section 4: The City Manager is hereby directed to take such acts or actions as may be needed or necessary with respect to reduce or eliminate all non-critical non-emergency expenditures of the city, including travel expenses, to ensure that expenditures do not exceed available funds for fiscal year 2010-2011.

Section 5: The City Manager is hereby authorized and directed to take such acts and actions as may be needed or necessary to establish and implement a plan to enforce and collect any and all unpaid fines due the San Luis Municipal Court, utilizing any and all available legal remedies in either civil or criminal law, including, but not limited to, the issuance and serving of warrants of arrest. The City Manager is authorized and directed to make such staffing reassignments as may be needed or necessary to implement and execute said plan. The Classification and Salary Plan of the City of San Luis is hereby amended to conform to said plan.

Section 6: The City Manager is authorized and directed to counsel with employees who may wish to seek early retirement or otherwise leave the city service and negotiate such severance or other agreements that he deems appropriate for the consideration of City Council.

Section 7: In the event of a conflict between the provisions of this resolution and any other ordinance, resolution, regulation, or policy of the City of San Luis, the conflicting provisions are hereby provisionally amended, superseded, and replaced, and the provisions of this resolution shall govern. In making this provision it is the specific legislative intent of the City Council that the Personnel Policies of the City of San Luis, the Classification plan of the City of San Luis, the salary plan of the City of San Luis, and the salary administration regulations and policies of the City of San Luis are hereby amended, superseded and/or replaced by this resolution such that actions and plans authorized hereunder shall govern and supersede any and all existing policies, regulations, or plans so that the actions and plans authorized hereunder may be implemented, and that this is a non-appealable final legislative decision and action of the City Council of the City of San Luis.

Section 8: If any section, subsection, sentence, clause, phrase, or portion of this resolution is for any reason held to be invalid or unconstitutional by the final decision of any court of competent jurisdiction, such decision shall not affect the validity of the remaining portions of this resolution.

Section 9: Whereas, it is necessary for the preservation of the peace, health, safety and welfare of the City of San Luis, Arizona, and for further reason that municipal services to the citizens of the City of San Luis may be provided in the most efficient manner possible without interruption in service, as well as the financial consideration of

the immediate need to ensure that expenditures do not exceed available funds for fiscal year 2010/2011, and that the best interests of the City require the provisions of this resolution to go into immediate effect, an emergency is hereby declared to exist, and this resolution shall become immediately operative and in force and effect from and after the date of posting hereof.

PASSED AND ADOPTED by the Mayor and Council of the City of San Luis, Arizona, this 10th day of February, 2011.



Juan Carlos Escamilla, Mayor

ATTEST:



Sonia Cuello, City Clerk

APPROVED AS TO FORM:



Glenn J. Gimbut
City Attorney



Resolution

NO. 1006

OFFICE OF THE
MAYOR
CITY OF SAN LUIS

A RESOLUTION OF THE MAYOR AND COUNCIL OF THE CITY OF SAN LUIS AUTHORIZING THE CITY MANAGER TO AMEND THE CLASSIFICATION AND SALARY PLAN OF THE CITY OF SAN LUIS; CREATE CERTAIN POSITIONS; AND MAKE OTHER PERSONNEL AND DEPARTMENTAL CHANGES IN PREPARATION FOR FISCAL YEAR 2013/2014

Whereas in order to provide for the most efficient delivery of service to the citizens of the City of San Luis, it has been determined that certain amendments to the Classification and Salary Plan of the City of San Luis and reorganization of city departments and divisions has become necessary;

NOW, THEREFORE, BE IT RESOLVED BY THE MAYOR AND CITY COUNCIL OF THE CITY OF SAN LUIS:

Section 1: The City Manager is hereby directed to prepare appropriate amendments to the Classification and Salary Plan of the City of San Luis in accordance with the provisions of this resolution as part of the budget process for fiscal year 2013/2014. The changes are to be as follows:

- a) The Building Safety Division of the Planning and Zoning Department is to be moved to be a division of the Department of Public Works;
- b) The position of Human Resources Director shall be renamed Human Relations Manager and shall be answerable to the City Manager. The City Manager shall make a recommendation regarding any changes to the range of salary for said position;
- e) The Parks and Recreation Department is to be changed to consist of five (5) divisions, namely Parks Grounds; Recreation; Youth Center; Cultural Center; and Aquatics. The City Manager shall recommend changes in positions, titles, and salary ranges for supervision of these divisions including the creation of the position of Parks Grounds Supervisor with a recommendation on range of salary;
- f) The creation of a traffic enforcement division of the Police Department. The City Manager is directed to make a recommendation regarding the creation of part

time traffic enforcement positions together with a recommended range of pay for such position(s);

g) To make recommendations regarding the creation of new positions or other changes within the departments of City Attorney, Development Services; Fire Department, Municipal Court, Public Works, Police Department; Finance, Facilities, Fleet Services; Human Resources; and Utilities as part of adoption of the budget for fiscal year 2013/2014.

PASSED AND ADOPTED by the Mayor and Council of the City of San Luis, Arizona, this 22nd day of May, 2013.



Gerardo Sanchez, Mayor

ATTEST:



Sonia Cuello, City Clerk

APPROVED AS TO FORM:

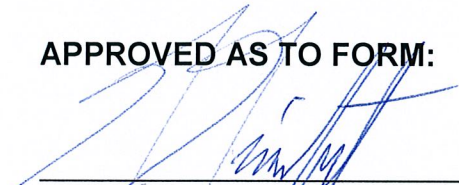

Glenn J. Gimbut, City Attorney



Resolution

NO. 1052

OFFICE OF THE
MAYOR
CITY OF SAN LUIS

A RESOLUTION OF THE MAYOR AND COUNCIL OF THE CITY OF SAN LUIS DIRECTING THE CITY MANAGER TO ESTABLISH AND IMPLEMENT GUIDELINES AND A PLAN FOR REDUCTION IN FORCE PURSUANT TO PERSONNEL POLICIES; AUTHORIZING AND DIRECTING A PLAN FOR LAYOFFS AND CONVERSION OF POSITIONS WITHIN THE CLASSIFIED SERVICE OF THE CITY; TO AUTHORIZE THE TAKING OF SUCH OTHER ACTS AND ACTIONS AS MAY BE NEEDED AND/OR NECESSARY TO ENSURE THAT CITY EXPENSES DO NOT EXCEED CITY REVENUES; SUPERSEDING ANY CONFLICTING PROVISIONS OF EXISTING REGULATIONS, POLICIES OR PROCEDURES; PROVIDING FOR SEVERABILITY; AND DECLARING AN EMERGENCY

Whereas A.R.S. §42-17101 requires incorporated cities and towns, on or before the third Monday in July of each year to prepare a full and complete statement of political subdivision's financial affairs for the preceding fiscal year and an estimate of the different amounts required to meet the political subdivision's public expense for the current fiscal year and A.R.S. §42-17105 provides that the governing body of a municipality must adopt proposed estimates of revenues and expenses as the budget for the current fiscal year and the amounts proposed to be spent shall not exceed the amounts proposed in the estimates;

Whereas A.R.S. §42-17106 places limitations on expenditures and limits expenditures to budgeted purposes;

Whereas the proposed department budgets for fiscal year 2014/2015 exceed anticipated revenues by approximately twelve million dollars;

Whereas in order to provide for the most efficient delivery of service to the citizens of the City of San Luis in fiscal year 2014/2015, and to maintain sound financial structure for the city in its finances and operations; it has been determined that certain changes to the operations of the City of San Luis and a restructuring of the delivery of services has become immediately necessary;

NOW, THEREFORE, BE IT RESOLVED BY THE MAYOR AND CITY COUNCIL OF THE CITY OF SAN LUIS:

Section 1: The City Manager is hereby directed and authorized to prepare and implement guidelines and a plan pursuant to Section 8.03 of the City of San Luis Personnel Policies, dated July 1, 2008, to layoff positions of up to ten (10) full time positions within the Classification and Salary Plan of the City of San Luis and to convert up to five (5) full time positions to part time positions, with the understanding that the total of laid off or converted positions shall not exceed a total of fifteen positions. That this authority shall include the authority to reassign duties, including supervisory duties, to remaining positions in order to provide for continuity of service. The Classification and Salary Plan is hereby amended to conform to said plan. The positions that will be subject to layoff and conversion are not being eliminated nor is this action to be considered an action of discipline, but rather this action is being taken solely as a budget measure in order to ensure that expected revenues for fiscal year 2014/2015 do not jeopardize the financial condition of the city. The period of layoff and conversion shall begin at such time as the plan is implemented by the City Manager and will last until further decision of the City Council. City Council, by this resolution, specifically reserves the right to make further decisions with respect to these positions as part of planning for fiscal year 2014/2015.

Section 2: The City Manager is hereby authorized and directed to take such steps as may be needed or necessary to reduce, suspend, or eliminate the accrual of overtime in all city departments, with the exception of overtime as actually paid by federal or state grants.

Section 3: The City Manager is authorized and directed to counsel with employees who may wish to seek early retirement or otherwise leave the city service and negotiate such severance or other agreements that he deems appropriate for the consideration of City Council.

Section 4: In the event of a conflict between the provisions of this resolution and any other ordinance, resolution, regulation, or policy of the City of San Luis, the conflicting provisions are hereby provisionally amended, superseded, and replaced, and the provisions of this resolution shall govern. In making this provision it is the specific legislative intent of the City Council that the Personnel Policies of the City of San Luis, the Classification plan of the City of San Luis, the salary plan of the City of San Luis, and the salary administration regulations and policies of the City of San Luis are hereby amended, superseded and/or replaced by this resolution such that actions and plans authorized hereunder shall govern and supersede any and all existing policies, regulations, or plans so that the actions and plans authorized hereunder may be implemented, and that this is a non-appealable final legislative decision and action of the City Council of the City of San Luis.

Section 5: If any section, subsection, sentence, clause, phrase, or portion of this resolution is for any reason held to be invalid or unconstitutional by the final decision of any court of competent jurisdiction, such decision shall not affect the validity of the remaining portions of this resolution.

Section 6: Whereas, it is necessary for the preservation of the peace, health, safety and welfare of the City of San Luis, Arizona, and for further reason that municipal services to the citizens of the City of San Luis may be provided in the most efficient manner possible

without interruption in service, as well as the financial consideration of the immediate need to ensure that expenditures do not exceed available funds for fiscal year 2014/2015, and that the best interests of the City require the provisions of this resolution to go into immediate effect, an emergency is hereby declared to exist, and this resolution shall become immediately operative and in force and effect from and after the date of posting hereof.

PASSED AND ADOPTED by the Mayor and Council of the City of San Luis,
Arizona, this 16th day of April, 2014.



Gerardo Sanchez, Mayor

ATTEST:



Sonia Cornelio, City Clerk

APPROVED AS TO FORM:

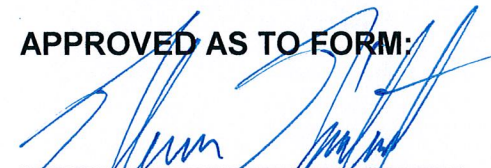

Glenn J. Gimbut, City Attorney



Resolution

NO. 1148

OFFICE OF THE
MAYOR
CITY OF SAN LUIS

A RESOLUTION OF THE MAYOR AND COUNCIL OF THE CITY OF SAN LUIS, ARIZONA, AUTHORIZING THE CITY MANAGER TO AMEND THE CLASSIFICATION AND 2006 SALARY PLAN OF THE CITY OF SAN LUIS; CREATE CERTAIN POSITIONS; AND MAKE OTHER PERSONNEL AND DEPARTMENTAL CHANGES TO INCLUDE TRANSFERS WITHIN THE ORGANIZATION, IN PREPARATION FOR FISCAL YEAR 2016-2017

WHEREAS, in order to provide for the most efficient delivery of service to the citizens of the City of San Luis and to maintain sound financial structure for the city in its finances and operations, it has been determined that certain amendments to the Classification and 2006 Salary Plan of the City of San Luis and reorganization of the city departments and divisions has become necessary;

WHEREAS, the City could experience a dramatic short-fall in business license revenue in the fiscal year 2016-2017 and the City needs to have a plan in place for such possible short-fall;

NOW, THEREFORE, BE IT RESOLVED by the Mayor and Council of the City of San Luis, Arizona:

Section 1: The City Manager is hereby directed to prepare appropriate amendments to the Classification and 2006 Salary Plan of the City of San Luis in accordance with the provisions of this resolution as part of the budget process for fiscal year 2016-2017.

The changes are to be as follows:

- a) The Development Services Division and the Building Safety Division shall be removed from the Public Works Department and is hereby transferred to be under the Planning and Zoning Department which shall be directly under City Administration. The Building Safety Director position will be converted to the Planning and Zoning Director.
- b) The City Prosecutor shall no longer be a contracted position. The City Prosecutor shall be a salaried position as part of the Classification and Salary Plan effective August 18, 2016.

Section 2: The City Manager is hereby authorized and directed to take such steps as may be needed or necessary to reduce, suspend, or eliminate the accrual of overtime in all city departments, with the exception of overtime as actually paid by federal or state grants. It is the legislative intent of the City Council to specifically disallow regular paid overtime until July 1, 2017.

Section 4: The City Manager is hereby directed to take such acts or actions as may be needed or necessary with respect to reduce or eliminate all non-critical non-emergency expenditures of the city to ensure that expenditures do not exceed available funds for fiscal year 2016-2017.

Section 5: The City Manager is authorized and directed to counsel with employees who may wish to seek early retirement or otherwise leave the city service and negotiate such severance or other agreements that he deems appropriate for the consideration of City Council.

Section 6: The City Manager is hereby directed and authorized to prepare and implement if necessary guidelines and a plan pursuant to Section 8.03 of the City of San Luis Personnel Policies, dated July 1, 2008, to lay-off full-time positions within the Classification and 2006 Salary Plan of the City of San Luis and to convert full-time positions to part-time positions as may be needed due to possible business license revenue short-falls. The positions that would be subject to layoff and conversion if there is such a shortfall would not be eliminated nor would such action be considered an action of discipline, but rather this action would be taken solely as a budget measure in order to ensure that in the event of a shortfall in business license revenue for the fiscal year 2016-2017 the financial condition of the city is not jeopardized. The period of lay-off and conversion would begin at such time as the plan is implemented by the City Manager and would last until further decision of the City Council. City Council, by this resolution, specifically reserves the right to make further decisions as to specific numbers of lay-offs and conversions as the need arises.

Section 7: In the event of a conflict between the provisions of this resolution and any other resolution, regulation, or policy of the City of San Luis, the conflicting provisions are hereby provisionally amended, superseded, and replaced, and the provisions of this resolution shall govern. In making this provision, it is the specific legislative intent of the City Council that the Personnel Policies of the City of San Luis, the Classification Plan of the City of San Luis, the 2006 Salary Plan of the City of City of San Luis, the salary administration regulations and policies of the City of San Luis are hereby amended, superseded and/or replaced by this resolution such that actions and plans authorized in this resolution shall govern and supersede any and all existing policies, regulations, or plans so that the action and plans authorized in this resolution may be implemented, and that this is a non-appealable final legislative decision and action of the City Council of the City of San Luis.

Section 8: If any section, subsection, sentence, clause, phrase, or portion of this resolution is for any reason held to be invalid or unconstitutional by the final decision of

any court of competent jurisdiction, such decision shall not affect the validity of the remaining portions of this resolution.

PASSED AND ADOPTED by the Mayor and Council of the City of San Luis, Arizona, this 8th day of June, 2016.



Gerardo Sanchez, Mayor

ATTEST:



Sonia Cornelio, City Clerk

APPROVED AS TO FORM:



Kay Marion Macuil, City Attorney



AGENDA ITEM REVIEW FORM

Regular City Council Meeting

6.B.

Meeting Date: 05/22/2019

Department Head: Angel Ramirez, Fire Chief, Fire Department

Submitted By: Angel Ramirez, Fire Chief, Fire Department

Action Requested: Motion

ITEM:

Discussion and possible action on any and all matters regarding the ratification of the purchase for a new Emergency Incident Command Vehicle. **(Angel Ramirez, Fire Chief)**

SUMMARY:

Previously, the purchase of an emergency command vehicle was approved for the Fire Department on the meeting held on January 23, 2019. Due to a misunderstanding, our vendor, Emergency Vehicle Group, was not able to use a code provided by GM Fleet that allows municipalities to buy vehicles at a reduced cost. They were not allowed to use the code directly, and only the City of San Luis was able to use the code directly from them. That meant that in order to receive the discounted price, the City of San Luis had to split the purchase between two (2) vendors. The purchase of the truck had to come directly from Selman Chevrolet Co., and the uplifting will be done by Emergency Vehicle Group. The cost of the emergency command vehicle will remain the same as it was previously approved. The only thing that the city will be modifying will be the vendor. The splitting of the purchase orders was run through our legal office and finance, where both were in agreement to split the purchase between both vendors so that we may keep the discount, avoid an increase of price due to time limitation and then submit for ratification approval from council. Purchase order 2019-00002580 in the amount of \$31,932.00 was issued to Emergency Vehicle Group for the uplifting of the command vehicle and purchase order 2019-00002601 in the amount of \$37,575.68 was issued to Selman Chevrolet Co. for the purchase of the vehicle. The cost savings are still going to take effect with the splitting of purchase orders.

Due to council approving this item on a previous meeting by waiving the procurement code as a unique vehicle with specialized equipment and for it not to exceed the price of \$74,000.00, staff would like to formally request the ratification of purchase orders 2019-00002580, Emergency Vehicle Group in the amount of \$31,932.00 and 2019-00002601, Selman Chevrolet Co. in the amount of \$37,575.68. Both amounts total \$69,507.68 plus tax and will not be exceeding the amount of \$74,000.00 as approved by the Mayor and City Council at their meeting held on January 23, 2019.

RECOMMENDATION / SUGGESTED MOTION:

I MOVE TO RATIFY PURCHASE ORDERS 2019-00002580 UNDER EMERGENCY VEHICLE GROUP IN THE AMOUNT OF \$31,932.00 PLUS TAX AND 2019-00002601 UNDER SELMAN CHEVROLET CO., IN THE AMOUNT OF \$37,575.68 PLUS TAX, BOTH PURCHASE ORDERS NOT TO EXCEED THE AMOUNT OF \$74,000.00.

N/A

Fiscal Impact

IS THERE FISCAL IMPACT ASSOCIATED WITH THIS ITEM: YES
CITY/STATE/FEDERAL FUNDS: CITY
TOTAL: \$74,000.00
BUDGETED AMOUNT: \$74,000.00
AVAILABLE AMOUNT TO TRANSFER: N/A
ACCT NAME & GL#/REMAINING BALANCE BEFORE PURCHASE: 806-860-90000.182
FISCAL IMPACT STATEMENT (IF THIS IS A BUDGET TRANSFER, YOU MUST ATTACH THE BUDGET ADJUSTMENT FORM):
N/A

Attachments

PO#2019-00002580
PO#2019-00002601
EVG quote Tahoe
Emails

Ship To

City of San Luis
Fire Department
1165 North McCain Avenue
San Luis, AZ 85349

Bill To

City of San Luis
Finance
P.O. Box 7740
San Luis, AZ 85349

Purchase Order
No. 2019-00002580

DATE 02/27/2019

VENDOR 9557 - EMERGENCY VEHICLE GROUP.

Contact

EMERGENCY VEHICLE GROUP, INC.
2883 E CORONADO ST.
ANAHEIM, CA 92806



PURCHASE ORDER NUMBER MUST APPEAR ON ALL INVOICES, SHIPPERS, BILL OF LADING AND CORRESPONDENCE

DELIVER BY
SHIP VIA
FREIGHT TERMS
PAGE 1 of 1
ORIGINATOR: Angelica Cifuentes

REFERENCE #

QUANTITY	UNIT	DESCRIPTION	UNIT COST	TOTAL COST
1.0000	EACH	EQUIPMENT - EMERGENCY INCIDENT COMMAND VEHICLE UPLIFTING 806-860-90000.182 - Capital Outlay - Equipment Fire 31,852.00	31,852.0000	\$31,852.00
1.0000	EACH	EQUIPMENT - DOCUMENT FEE 806-860-90000.182 - Capital Outlay - Equipment Fire 80.00	80.0000	\$80.00
			TOTAL DUE	\$31,932.00

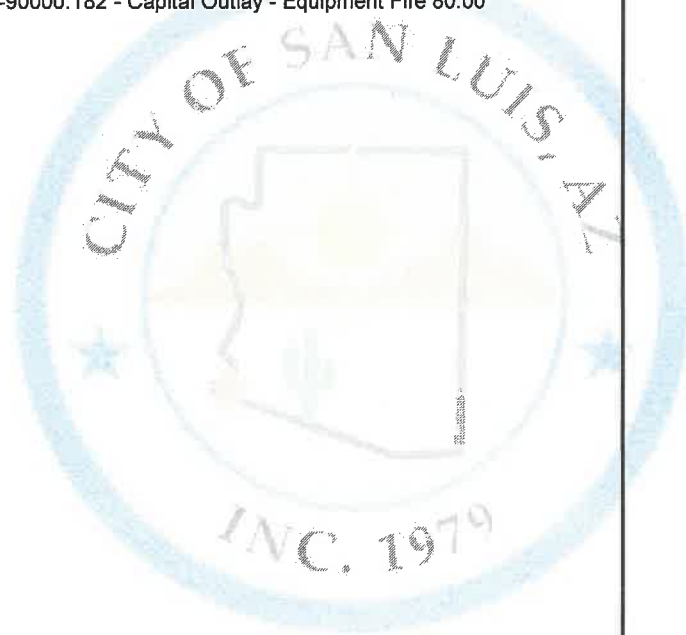

Special Instructions

REFERENCE PO#2019-2208. IN ORDER TO GET VENDOR DISCOUNT WE NEEDED TO SEPARTE THE PO INTO 2 PURCHASE ORDERS. ORIGINAL PO WILL BE VOIDED.

1. Shipments may be refunded if the Purchase Order No. is not shown on shippers and bill of lading.
2. Exempt from state local and federal taxes.
3. Substitute will not be accepted without prior approval.
4. C.O.D. or collect shipments will not be accepted.
5. Partial shipments will be accepted if invoiced separately.
6. Receiving hours are 6:00 AM to 3:00 PM Monday thru Friday.
7. Purchase Orders comply with City Procurement Policy Regulations as stated on City Ordinance No. 219.
8. All invoices must be mailed to the Finance Department.



February 19, 2019

Purchasing Agent III Angelica Cifuentes
City of San Luis
Fire Department
1165 North McCane Avenue
San Luis, Arizona 85349

RE: Offer to Provide Vehicle Upfitting on a City of San Luis, AZ supplied 2019 Chevrolet Tahoe, 4 x 2, Gasoline Powered Four Door Chassis

Attention: Purchasing Agent III Angelica Cifuentes

On behalf of Emergency Vehicle Group, Inc., I would like to thank you for the opportunity to provide you with the following offer for the City of San Luis, AZ to purchase Vehicle Upfitting on a City of San Luis supplied 2019 Chevrolet Tahoe, 4 x 2, Gasoline Powered Four Door Chassis.

Emergency Vehicle Group, Inc. (EVG) is proud to be in the business of serving those who bravely serve our communities and help ensure the safety of our families and friends. Our pledge is to offer you the same quality of service and expertise that is demanded from you. Over the years we have introduced fire departments, municipalities and private companies to the absolute best in service, sales and support for emergency vehicle products.

We proudly serve California, Arizona and Nevada and offer you premium custom products along with the best value available in the industry. EVG accomplishes this by representing Spartan Emergency Response, SMEAL Fire Apparatus, LTC, US Tanker, SVI Trucks, Wheeled Coach Ambulance, Road Rescue Ambulance, and McCoy Miller Ambulances as well as offering ambulance remount services and command vehicles built by EVG.

EVG employs EVT and ASE Certified Mechanics with decades of experience in servicing emergency vehicles, fire apparatus and ambulances. EVG recognizes the importance of these vehicles as a life saving device and take great pride in serving those that bravely serve and protect us. Our corporate office, remount and main service facility is located in Anaheim, CA.

Our mission is to develop long-term relationships and provide our customers with "honest, intelligent effort" All of us at Emergency Vehicle Group, Inc. believe in long-term relationships and we look forward to the opportunity of working with you and the City of San Luis. I would again like to thank you for the opportunity. Each of us at EVG offer you our sincere pledge of "Honest, Intelligent Effort" in everything we do for you now, and in the future.

Sincerely,

A handwritten signature in blue ink, appearing to read "James Weber", is written over a horizontal line.

James Weber
Inside Sales Manager



The Following is an Offer and Purchase Agreement for:

City of San Luis To Purchase
Vehicle Upfitting(s) on a City of San Luis, AZ Supplied 2019 Chevrolet Tahoe, 4 x 2, Gasoline
Powered Four Door Chassis
February 19, 2019

Table with 4 columns: Description, Qty, Price Each, Extended Price. Rows include Vehicle Upfitting on a City of San Luis, AZ Supplied 2019 Chevrolet Tahoe, 4 x 2, Gasoline Powered Four Door Chassis and Document Fee.

This constitutes a contract for the purchase and sale of Vehicle Upfitting on a City of San Luis, AZ supplied 2019 Chevrolet Tahoe, 4 x 2, Gasoline Powered Four Door Chassis between Emergency Vehicle Group, Inc. (Seller) and the City of San Luis (Buyer) in the total amount of:

Thirty One Thousand Nine Hundred Thirty Two Dollars and No Cents
\$31,932.00

Offer based on work order/specification reference number 01167-T2R0K2 and any associated drawing(s) as provided. A final approval work order/specification and drawing will be provided after all Pre-Construction changes are completed (if applicable). Pre-Construction changes may incur an additional cost.

Payment Terms: 100% payment of the contract is due at the time of delivery. Failure to pay the contract in full may result in interest accruing at an annual percentage rate of 6%. Proof of insurance and approved financing or payment will be required to execute this contract.

Delivery Time: Delivery shall be 90 days after receipt of chassis and approved work order and production drawings of the vehicle.

Signature below represents acceptance of above contract and terms:

City of San Luis:
Angelica Cifuentes 2-27-19
Signature Date
Angelica Cifuentes
Printed Name
Purchasing Coordinator
Title

Emergency Vehicle Group:
Signature Date 2/19/2019
James Weber
Printed Name
Inside Sales Manager
Title

Ship To
 City of San Luis
 Fire Department
 1165 North McCain Avenue
 San Luis, AZ 85349

Bill To
 City of San Luis
 Finance
 P.O. Box 7740
 San Luis, AZ 85349

Purchase Order
 No. 2019-00002601

DATE 02/27/2019

VENDOR 10252 - SELMAN CHEVROLET CO

Contact
 SELMAN CHEVROLET CO
 1800 E CHAPMAN AVE
 ORANGE, CA 92867



PURCHASE ORDER NUMBER MUST APPEAR ON ALL INVOICES, SHIPPERS, BILL OF LADING AND CORRESPONDENCE

DELIVER BY
SHIP VIA
FREIGHT TERMS
 PAGE 1 of 1
ORIGINATOR: Angelica Cifuentes

REFERENCE #

QUANTITY	UNIT	DESCRIPTION	UNIT COST	TOTAL COST
1.0000	EACH	VEHICLES - 2019 CHEVROLET WILL BE USED AS COMMAND VEHICLE ONE EMERGENCY VEHICLE GROUP COMMAND VEHICLE ON 2019 CHEVROLET, 4 X 2, GASOLINE POWERED FOUR DOOR CAB CHASSIS 806-860-90000.182 - Capital Outlay - Equipment Fire 48,986.00	48,986.0000	\$48,986.00
1.0000	EACH	DISCOUNT/CREDIT - VENDOR DISCOUNT 806-860-90000.182 - Capital Outlay - Equipment Fire (11,525.32)	(11,525.3200)	(\$11,525.32)
1.0000	EACH	VEHICLE TITLE & REGISTRATION FEES - DOC FEES 806-860-90000.182 - Capital Outlay - Equipment Fire 85.00	85.0000	\$85.00
1.0000	EACH	VEHICLE TITLE & REGISTRATION FEES - TAG/REGISTRATION ESTIMATE 806-860-90000.182 - Capital Outlay - Equipment Fire 30.00	30.0000	\$30.00
TOTAL DUE				\$37,575.68

Special Instructions

REFERENCE PO#2019-2208. IN ORDER TO GET VENDOR DISCOUNT WE NEEDED TO SEPARTE THE PO INTO 2 PURCHASE ORDERS. ORIGINAL PO WILL BE VOIDED.

- Shipments may be refunded if the Purchase Order No. is not shown on shippers and bill of lading.
- Exempt from state local and federal taxes.
- Substitute will not be accepted without prior approval.
- C.O.D. or collect shipments will not be accepted.
- Partial shipments will be accepted if invoiced separately.
- Receiving hours are 6:00 AM to 3:00 PM Monday thru Friday.
- Purchase Orders comply with City Procurement Policy Regulations as stated on City Ordinance No. 219.
- All invoices must be mailed to the Finance Department.



**BUSINESS
ELITE**

PREPARED FOR: City of San Luis, AZ

DATE: 11/2/18
 DEAL # _____
 MANAGER _____
 SALESPERSON Gennis Graham

VEHICLE: 2019 Chevy Tahoe
 STOCK # _____
 VIN _____
 MILES _____

BODY _____

MSRP \$48,885.00
 MISC. \$0.00
 GM CUSTOMER REBATES \$0.00
 SELMAN DISCOUNT \$11,525.32
 TOTAL DISCOUNTS \$11,525.32
TOTAL COST \$37,460.68

TRADE ALLOWANCE \$0.00
 DOC FEES \$85.00
 TAG/REGISTRATION (ESTIMATE) \$30.00
 SALES TAX (ESTIMATE) \$0.00

TOTAL OUT THE DOOR: \$37,575.68

PRICING BASED CURRENT GM DISCOUNTS, VALID TILL 10/31/18

FINANCE OPTIONS

	MONTHS	36	48	60	72
CASH DOWN					

ALL VEHICLES ARE SUBJECT TO PRIOR SALE OR TRADE. AMOUNTS ABOVE ARE ESTIMATES ONLY AND MAY VARY BASED ON APPROVED CREDIT, APPLICABLE TAXES, VEHICLE SELECTION, TRADE VALUE, ESTIMATED PAYOFF, ELIGIBILITY FOR REBATES AND OTHER FACTORS PARTICULAR TO YOUR TRANSACTION.

BUYER _____ DATE _____

SALES MGR. _____



[Fleet] 2019 Chevrolet Tahoe (CC15706) 2WD 4dr

Selected Model and Options

MODEL			
CODE	MODEL	Invoice	MSRP
CC15706	2019 Chevrolet Tahoe 2WD 4dr Commercial	\$43,991.40	\$46,700.00

COLORS			
CODE	DESCRIPTION	Invoice	MSRP
G1E	Siren Red Tintcoat	\$450.45	\$495.00

PREFERRED EQUIPMENT GROUP			
CODE	DESCRIPTION	Invoice	MSRP
1FL	Commercial Preferred Equipment Group	\$0.00	\$0.00

ADDITIONAL EQUIPMENT - INTERIOR			
CODE	DESCRIPTION	Invoice	MSRP
5HP	Key, 6 additional keys	\$37.31	\$41.00
JF4	Pedals, power-adjustable for accelerator and brake	\$136.50	\$150.00
LTQ	Content theft alarm disable	\$45.50	\$50.00

ADDITIONAL EQUIPMENT - MECHANICAL			
CODE	DESCRIPTION	Invoice	MSRP
K4B	Battery, Auxillary, 730 CCA	\$172.90	\$190.00
V76	Recovery hooks, 2 front, frame-mounted, Black	\$45.50	\$50.00

ADDITIONAL EQUIPMENT - SAFETY-INTERIOR			
CODE	DESCRIPTION	Invoice	MSRP
UE0	OnStar, delete	(\$77.35)	(\$85.00)

ADDITIONAL EQUIPMENT - EXTERIOR			
CODE	DESCRIPTION	Invoice	MSRP
VK3	License plate front mounting package	\$0.00	\$0.00

At the user's request, prices for this vehicle have been formulated on the basis of Initial Pricing for the vehicle, however GM cannot guarantee that Initial Pricing is available. This document contains information considered Confidential between GM and its Clients uniquely. The information provided is not intended for public disclosure. Prices, specifications, and availability are subject to change without notice, and do not include certain fees, taxes and charges that may be required by law or vary by manufacturer or region. Performance figures are guidelines only, and actual performance may vary. Photos may not represent actual vehicles or exact configurations. Content based on report preparer's input is subject to the accuracy of the input provided.
Data Version: 7593. Data Updated: Feb 4, 2019 9:35:00 PM PST.



[Fleet] 2019 Chevrolet Tahoe (CC15706) 2WD 4dr

ADDITIONAL EQUIPMENT - OTHER

CODE	DESCRIPTION	Invoice	MSRP
VQ2	Fleet processing option	\$0.00	\$0.00

SEAT TYPE

CODE	DESCRIPTION	Invoice	MSRP
AZ3	Seating, front 40/20/40 split-bench	\$0.00	\$0.00

GVWR

CODE	DESCRIPTION	Invoice	MSRP
C5Y	GVWR, 7100 lbs (3221 kg)	\$0.00	\$0.00

PAINT

CODE	DESCRIPTION	Invoice	MSRP
G1E	Siren Red Tintcoat	\$450.45	\$495.00

AXLE

CODE	DESCRIPTION	Invoice	MSRP
GU4	Rear axle, 3.08 ratio	\$0.00	\$0.00

SEAT TRIM

CODE	DESCRIPTION	Invoice	MSRP
H0U	Jet Black, Cloth seat trim	\$0.00	\$0.00

RADIO

CODE	DESCRIPTION	Invoice	MSRP
I05	Audio system, 8" diagonal color touch-screen with Chevrolet Infotainment	\$0.00	\$0.00

ENGINE

CODE	DESCRIPTION	Invoice	MSRP
L83	Engine, 5.3L EcoTec3 V8 with Active Fuel Management, Direct Injection and Variable Valve Timing	\$0.00	\$0.00

At the user's request, prices for this vehicle have been formulated on the basis of Initial Pricing for the vehicle, however GM cannot guarantee that Initial Pricing is available. This document contains information considered Confidential between GM and its Clients uniquely. The information provided is not intended for public disclosure. Prices, specifications, and availability are subject to change without notice, and do not include certain fees, taxes and charges that may be required by law or vary by manufacturer or region. Performance figures are guidelines only, and actual performance may vary. Photos may not represent actual vehicles or exact configurations. Content based on report preparer's input is subject to the accuracy of the input provided.
Data Version: 7593. Data Updated: Feb 4, 2019 9:35:00 PM PST.



[Fleet] 2019 Chevrolet Tahoe (CC15706) 2WD 4dr

TRANSMISSION

CODE	DESCRIPTION	Invoice	MSRP
MYC	Transmission, 6-speed automatic, electronically controlled	\$0.00	\$0.00

TIRES

CODE	DESCRIPTION	Invoice	MSRP
RC3	Tires, P265/70R17 all-terrain, blackwall	\$0.00	\$0.00

SPARE TIRE

CODE	DESCRIPTION	Invoice	MSRP
RC4	Tire, spare P265/70R17 all-season, blackwall	Inc.	Inc.

WHEEL TYPE

CODE	DESCRIPTION	Invoice	MSRP
RD6	Wheels, 17" x 8" (43.2 cm x 20.3 cm) painted steel	\$0.00	\$0.00

EMISSIONS

CODE	DESCRIPTION	Invoice	MSRP
YF5	Emissions, California state requirements	\$0.00	\$0.00

SUSPENSION PKG

CODE	DESCRIPTION	Invoice	MSRP
ZW7	Suspension Package, Premium Smooth Ride	\$0.00	\$0.00

PAINT SCHEME

CODE	DESCRIPTION	Invoice	MSRP
ZY1	Paint scheme, solid application	\$0.00	\$0.00

Options Total \$810.81 \$891.00

At the user's request, prices for this vehicle have been formulated on the basis of Initial Pricing for the vehicle, however GM cannot guarantee that Initial Pricing is available. This document contains information considered Confidential between GM and its Clients uniquely. The information provided is not intended for public disclosure. Prices, specifications, and availability are subject to change without notice, and do not include certain fees, taxes and charges that may be required by law or vary by manufacturer or region. Performance figures are guidelines only, and actual performance may vary. Photos may not represent actual vehicles or exact configurations. Content based on report preparer's input is subject to the accuracy of the input provided.
Data Version: 7593. Data Updated: Feb 4, 2019 9:35:00 PM PST.



(Fleet) 2019 Chevrolet Tahoe (CC15706) 2WD 4dr

Price Summary

PRICE SUMMARY

	VQ2	MSRP
Base Price	\$42,681.60	\$46,800.00
Total Options	\$784.08	\$891.00
Vehicle Subtotal	\$43,465.68	\$47,691.00
Destination Charge	\$1,295.00	\$1,295.00
Grand Total	\$44,760.68	\$48,986.00

Fleet - 7500
37,460.68

This document contains information considered Confidential between GM and its Clients uniquely. The information provided is not intended for public disclosure. Prices, specifications, and availability are subject to change without notice, and do not include certain fees, taxes and charges that may be required by law or vary by manufacturer or region. Performance figures are guidelines only, and actual performance may vary. Photos may not represent actual vehicles or exact configurations. Content based on report preparer's input is subject to the accuracy of the input provided.

Date Version: 7583. Data Updated: Feb 4, 2019 9:35:00 PM PST.



December 21, 2018

Captain Robert Solis
City of San Luis
1165 N. McCane Ave.
San Luis, Arizona 85349

RE: Offer to Provide One (1) Emergency Vehicle Group Command/Battalion Vehicle(s) on 2019 Chevrolet , 4 x 2, Gasoline Powered Four Door Cab Chassis

Attention: Captain Robert Solis

On behalf of Emergency Vehicle Group, Inc., I would like to thank you for the opportunity to provide you with the following offer for the City of San Luis to purchase One (1) Emergency Vehicle Group Command/Battalion Vehicle(s) on 2019 Chevrolet , 4 x 2, Gasoline Powered Four Door Cab Chassis

Emergency Vehicle Group, Inc. (EVG) is proud to be in the business of serving those who bravely serve our communities and help ensure the safety of our families and friends. Our pledge is to offer you the same quality of service and expertise that is demanded from you. Over the years we have introduced fire departments, municipalities and private companies to the absolute best in service, sales and support for emergency vehicle products.

We proudly serve California, Arizona and Nevada and offer you premium custom products along with the best value available in the industry. EVG accomplishes this by representing Spartan Emergency Response, SMEAL Fire Apparatus, LTC, US Tanker, SVI Trucks, Wheeled Coach Ambulance, Road Rescue Ambulance, and McCoy Miller Ambulances as well as offering ambulance remount services and command vehicles built by EVG.

EVG employs EVT and ASE Certified Mechanics with decades of experience in servicing emergency vehicles, fire apparatus and ambulances. EVG recognizes the importance of these vehicles as a life saving device and take great pride in serving those that bravely serve and protect us. Our corporate office, remount and main service facility is located in Anaheim, CA.

Our mission is to develop long-term relationships and provide our customers with "honest, intelligent effort" in everything we do for you. We are committed to do whatever it takes to surpass customers' expectations by continually improving upon what we do.

All of us at Emergency Vehicle Group, Inc. believe in long-term relationships and we look forward to the opportunity of working with you and the City of San Luis. I would again like to thank you for the opportunity. Each of us at EVG offer you our sincere pledge of "Honest, Intelligent Effort" in everything we do for you now, and in the future.

Sincerely,

A handwritten signature in blue ink that reads "Garrett Adelman".

Garrett Adelman

Regional Account Manager



The Following is an Offer and Purchase Agreement for:

City of San Luis To Purchase

One (1) Emergency Vehicle Group Command/Battalion Vehicle(s) on 2019 Chevrolet , 4 x 2, Gasoline Powered Four Door Cab(s)

December 21, 2018

Description	Qty	Price Each	Extended Price
One (1) Emergency Vehicle Group Command/Battalion Vehicle(s) on 2019 Chevrolet , 4 x 2, Gasoline Powered Four Door Cab Chassis Chassis VIN Number(s): To Be Determined After Production Start	1	\$69,428.00	\$69,428.00
Document Fee	1	\$80.00	\$80.00
Total Purchase Price	1	\$69,508.00	\$69,508.00

This constitutes a contract for the purchase and sale of One (1) Emergency Vehicle Group Command/Battalion Vehicle(s) on 2019 Chevrolet , 4 x 2, Gasoline Powered Four Door Cab chassis between Emergency Vehicle Group, Inc. (Seller) and the City of San Luis (Buyer) in the total amount of:

Sixty Nine Thousand Five Hundred Eight Dollars and No Cents
\$69,508.00

Offer based on work order/specification and any associated drawing(s) as provided. A final approval work order/specification and drawing will be provided after all Pre-Construction changes are completed (if applicable). Pre-Construction changes may incur an additional cost.

Payment Terms: 100% payment of the contract is due at the time of delivery. Failure to pay the contract in full may result in interest accruing at an annual percentage rate of 6%. Proof of insurance and approved financing or payment will be required to execute this contract.

Delivery Time: Delivery shall be 90 days after receipt of chassis and approved work order and production drawings of the vehicle.

Signature below represents acceptance of above contract and terms:

City of San Luis:

Signature Date

Printed Name

Title

Emergency Vehicle Group:

 12/21/2018

Signature Date

Garrett Adelman

Printed Name

Regional Account Manager

Title

Sonia Cornelio

From: Angel Ramirez
Sent: Thursday, May 16, 2019 8:44 AM
To: Sonia Cornelio
Subject: Fwd: Chassis for Command Vehicle

Sent from my iPhone

Begin forwarded message:

From: Glenn Gimbut <GGimbut@cityofsanluis.org>
Date: February 17, 2019 at 6:57:15 PM MST
To: Monica Castro <mcastro@cityofsanluis.org>
Cc: Kay Macuil <kmacuil@cityofsanluis.org>, Angelica Cifuentes <ACifuentes@cityofsanluis.org>, Angel Ramirez <ARamirez@cityofsanluis.org>
Subject: Re: Chassis for Command Vehicle

Sounds good

Sent from my iPhone

On Feb 17, 2019, at 6:03 PM, Monica Castro <mcastro@cityofsanluis.org> wrote:

Hello all,

Let's not risk in getting the equipment at a higher cost. Let's proceed with purchase, but we should get ratification to council at a later council meeting as a backup in case this is questioned during an audit.

Thank you,

Monica

From: Glenn Gimbut
Sent: Sunday, February 17, 2019 3:38 PM
To: Kay Macuil <kmacuil@cityofsanluis.org>
Cc: Angelica Cifuentes <ACifuentes@cityofsanluis.org>; Monica Castro <mcastro@cityofsanluis.org>; Angel Ramirez <ARamirez@cityofsanluis.org>
Subject: Re: Chassis for Command Vehicle

Monica, ratification works as a "belt and suspenders" conservative play and will always pass audit

Sent from my iPhone

On Feb 16, 2019, at 9:09 PM, Kay Macuil <kmacuil@cityofsanluis.org> wrote:

This one I defer to Monica which option will pass audit. Do it without going to Council, or getting ratification from Council.

Kay

CONFIDENTIALITY NOTICE: This e-mail and any attachment to it are **STRICTLY CONFIDENTIAL** and may contain privileged information only for the intended recipient or recipients. If the reader of this e-mail is not the intended recipient, or the employee or agent responsible for delivering it to the intended recipient, this notifies you that reading the e-mail is strictly prohibited. If you have received this e-mail in error, please immediately notify me by reply e-mail at kmacuil@cityofsanluis.org and delete the e-mail and all attachments from your system. Thank you.

From: Glenn Gimbut
Sent: Thursday, February 14, 2019 1:20 PM
To: Angelica Cifuentes <ACifuentes@cityofsanluis.org>; Kay Macuil <kmacuil@cityofsanluis.org>; Monica Castro <mcastro@cityofsanluis.org>
Cc: Angel Ramirez <ARamirez@cityofsanluis.org>
Subject: RE: Chassis for Command Vehicle

I have looked through this and it is a very close call. Council waived formal purchasing requirements as this is a unique vehicle with specialized equipment. They approved with a not to exceed price. The principal vendor is requesting a splitting of Purchase Orders so that the City can get a discount on the chassis which is coming from General Motors. As a result we are still buying from and dealing with that vendor as approved by council, it is the vendor who is requesting the splitting of POs so that they can sell at the quoted price. Under that theory we are still buying from that vendor at the price approved by Council and the splitting is simply administration to carry out the direction of Council.

On the other hand we will be issuing a PO to a different vendor and cutting a separate check. I leave it to Monica as to what she thinks will pass audit.

One option is to do it and have council ratify the action at a later council meeting. I am going to assume if this drags out we wont be able to hold to the quoted price – hence a reason to just get this done now.

Kay,

Boss what do you think?

From: Angelica Cifuentes
Sent: Wednesday, February 13, 2019 5:52 PM
To: Kay Macuil <kmacuil@cityofsanluis.org>; Glenn Gimbut <GGimbut@cityofsanluis.org>
Cc: Angel Ramirez <ARamirez@cityofsanluis.org>
Subject: FW: Chassis for Command Vehicle

Hello Kay and Glenn,

Please see email below. It pertains to the approved agenda item from our Fire Department regarding an emergency command vehicle. This purchase was approved by council on the meeting of the 23rd of January. See below. The question is if we would have to take this item back to council to amend the motion or if we can go ahead and issue 2 separate purchase orders, one for the uplifting through EVG and the other one for the chassis through the Chevy dealer. Originally the whole purchase was going to be through EVG and that is how it was presented. Please advise as soon as possible as we are in a time crunch in order to meet our end of the fiscal year cutoff date of June 30th. Thank you.

<image001.png>

Angelica Cifuentes, CPP, CPM

Purchasing Agent III
Finance Department
(928) 341-8548 Direct Line
(928) 341-8549 Fax
acifuentes@cityofsanluis.org
www.cityofsanluis.org

From: James Weber [<mailto:jweber@evginc.net>]
Sent: Wednesday, February 13, 2019 4:52 PM
To: Angelica Cifuentes <ACifuentes@cityofsanluis.org>
Subject: Chassis for Command Vehicle

Hi Angelica,

I have an issue on the Command truck project that I need your help with.

When this project was originally proposed, we were told by our chassis supplier that we could order the truck using the City of San Luis' FAN code (the GM code that allows municipalities to buy vehicles at a reduced cost). It turns out that that was not accurate. GM fleet will not allow us to purchase the truck using your code; they will only allow the City of San Luis to purchase it. We have spent the last couple of weeks going back and forth with our Chevy dealer and GM Fleet to try and have them sell it to the City and allow EVG to make the payment, but they will not allow this either.

The only thing they will allow is for the City to issue the PO and make the payment. If we can't do that, they won't provide the discount.

Is it possible for you to split the PO's for this project and issue one to EVG for the upfitting, and one to our Chevy dealer for the cost of the chassis? If we can't do that, I'm not sure how we will be able to get the chassis purchased as there is a significant cost that would need to be added in by losing the GM rebate.

Please let me know your thoughts.

Thanks,
James Weber | Inside Sales Manager
Emergency Vehicle Group, Inc.

2883 E. Coronado St. | Anaheim, CA 92806

Direct: 714.500.7455 | Cell: 714.749.7978

jweber@evginc.net | www.evginc.net

<image002.png> <image003.png>



AGENDA ITEM REVIEW FORM

Regular City Council Meeting

6.C.

Meeting Date: 05/22/2019

Department Head: Lizandro Galaviz, Director of Parks & Recreation, Parks & Recreation Department

Submitted By: Crystal Fragozo, Administrative Assistant, Parks & Recreation Department

Action Requested: Motion
Public Hearing

ITEM:

Public hearing followed by discussion and possible action on any and all matters regarding the recommendation of a Special Event Liquor License application to the Arizona Department of Liquor Licenses and Control to authorize the City of San Luis Parks & Recreation Department to sell alcohol at the 4th of July Celebration to be held July 4, 2019. **(Lizandro Galaviz, Director of Parks and Recreation)**

- A. Open public hearing
 - 1. Presentation by staff and/or applicant
 - 2. Call to the public on this item
- B. Close public hearing
- C. Action on Special Event Liquor License Application to the Arizona Department of Liquor Licenses & Control

SUMMARY:

The City of San Luis Parks & Recreation Department wishes to sell alcohol at the 4th of July Celebration to be held July 4, 2019, from 4:00 p.m. to 12:00 a.m. at the San Luis Joe Orduño Park. The City of San Luis Parks & Recreation Department will be assisted by the San Luis FRONTERA Rotary Club. The City of San Luis Parks & Recreation Department will keep 25% of the beer proceeds and the San Luis FRONTERA Rotary Club will keep 75% of the beer proceeds.

RECOMMENDATION / SUGGESTED MOTION:

- A. I MOVE TO OPEN PUBLIC HEARING.**
 - 1. Presentation by staff and/or applicant**
 - 2. Call to the public on this item**
- B. I MOVE TO CLOSE PUBLIC HEARING**
- C. I MOVE TO RECOMMEND APPROVAL TO THE ARIZONA DEPARTMENT OF LIQUOR LICENSES AND CONTROL THE SPECIAL EVENT LIQUOR LICENSE APPLICATION FOR THE CITY OF SAN LUIS, PARKS & RECREATION DEPARTMENT AS PRESENTED**

N/A

Fiscal Impact

IS THERE FISCAL IMPACT ASSOCIATED WITH THIS ITEM: NO
CITY/STATE/FEDERAL FUNDS: N/A
TOTAL: N/A

BUDGETED AMOUNT: N/A

AVAILABLE AMOUNT TO TRANSFER: N/A

ACCT NAME & GL#/REMAINING BALANCE BEFORE PURCHASE: N/A

FISCAL IMPACT STATEMENT (IF THIS IS A BUDGET TRANSFER, YOU MUST ATTACH THE BUDGET ADJUSTMENT FORM):

There is no associated fiscal impact with this item.

Attachments

Special Event Liquor License Application - 2019 Founders Day Celebration



Arizona Department of Liquor Licenses and Control
 800 W Washington 5th Floor
 Phoenix, AZ 85007-2934
 www.azliquor.gov
 (602) 542-5141

FOR DLLC USE ONLY

Event Date(s):
Event time start/end:
CSR:
License:

APPLICATION FOR SPECIAL EVENT LICENSE
 Fee= \$25.00 per day for 1-10 days (consecutive)
 Cash Checks or Money Orders Only

A service fee of \$25.00 will be charged for all dishonored checks (A.R.S § 44-6852)

IMPORTANT INFORMATION: This document must be fully completed or it will be returned.

The Department of Liquor Licenses and Control must receive this application ten (10) business days prior to the event. If the special event will be held at a location without a permanent liquor license or if the event will be on any portion of a location that is not covered by the existing liquor license, this application must be approved by the local government before submission to the Department of Liquor Licenses and Control (see Section 12).

SECTION 1 Name of Organization: City of San Luis, Arizona

Name of Licensed Contractor **only** (if any): _____

SECTION 2 Non-Profit/IRS Tax Exempt Number: 86-0376164

SECTION 3 Event Location: Joe Orduno Park

Event Address: 965 N. Park Ave.

SECTION 4 Applicant must be a member of the qualifying organization and authorized by an Officer, Director, or Chairperson of the Organization.

- Applicant: Galaviz Lizandro R. 05/05/1970
Last First Middle Date of Birth
- Applicant's mailing address: PO Box 1170 San Luis Arizona 85349
Street City State Zip
- Applicant's home/cell phone: (928) 919-8613 Applicant's business phone: (928) 341-8535
Street City State Zip
- Applicant's email address: lgalaviz@cityofsanluis.org

I, (Print Full Name) Lizandro R. Galaviz declare that I am the APPLICANT filing this application as listed above. I have read the application and the contents and all statements are true, correct and complete.

X [Signature] Parks & Recreation Director 5/8/19 928-919-8613
Signature Title/ Position Date Phone Number

The foregoing instrument was acknowledged before me this 8TH MAY 2019
Day Month Year

State ARIZONA County of YUMA

My Commission Expires on: 09/28/2021 [Signature]
Date Signature of Notary Public



SECTION 5 Regarding the Applicant's application for a special event permit, I hereby certify that the Organization meets the criteria in A.R.S. § 4-203.02(E) for the issuance of the permit as indicated by checking one of the boxes below.

- (1) The Applicant is a political party or a campaign committee supporting a candidate for public office. Please indicate the name of the candidate that the Applicant supports, the office that the candidate seeks, and the month and year that the applicant would first fill the office if successful.

Candidate: _____

Name	Office	Month/Year
------	--------	------------

- (2) The Applicant is a non-profit entity organized in Arizona, or pursuant to the laws of another state that is eligible for designation as a nonprofit entity under Section 501(C) of the internal revenue code of the United States. If the Applicant is applying under option (2) as a nonprofit entity, **please also INITIAL in the space provided next to all following statements to indicate that, to the best of the applicant's knowledge, they are true and correct.**

_____ The Applicant has received a determination letter from the Internal Revenue Service ("IRS") indicating that it is eligible for designation as a nonprofit entity under Section 501(C), eligibility or will be eligible on all days that the special event will occur, or has a pending application with the IRS for such treatment that has not been resolved but that will retroactively cover all days that the special event will occur. (Please provide a copy of either the IRS determination letter or the application [without attachments] with this application).

_____ The Applicant is not aware of any action by the IRS to revoke, suspend, or otherwise eliminate the Applicant's eligibility under 501(C), or if there is a pending application, the Applicant has not received any indication that the IRS will deny its application and has a good faith basis formed upon a reasonable inquiry into IRS regulations, guidelines, and forms that it is eligible under 501(C).

_____ The Applicant understands that if there is a change in circumstances after completing this form that may cause or has caused it to lose its eligibility under 501(C), whether before or after receiving an IRS determination letter, that it has an affirmative duty to notify the Department of Liquor, which may then take appropriate action with regard to the loss of eligibility.

To be completed only by an Officer, Director, or Chairperson of the organization.

I, (Print Full Name) Lizandro GALAVIZ declare that I am an Officer, Director, or Chairperson of the organization filing this application as listed above. I have read the application and the contents and all statements are true, correct and complete.

X [Signature] Parks & Rec. Dept. 5/8/19 928-919-8613
 Signature Title/ Position Date Phone Number

The foregoing instrument was acknowledged before me this 8th MAY 2019
 Day Month Year

State ARIZONA County of YUMA

My Commission Expires on: 09/28/2021 [Signature]
 Date Signature of Notary Public

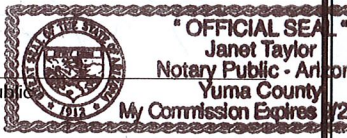

SECTION 6 Will this event be held on a currently licensed premise and within the already approved premises? Yes No
 (If yes, Local Governing Body Signature not required)

 Name of Business License Number Phone (Include Area Code)

SECTION 7 How is this special event going to conduct all dispensing, serving, and selling of spirituous liquors? Please read R-19-318 for explanation and check one of the following boxes.

- Place license in non-use
- Dispense and serve all spirituous liquors under retailer's license
- Dispense and serve all spirituous liquors under special event
- Split premise between special event and retail location

(IF USING RETAIL LICENSE, PLEASE SUBMIT A LETTER OF AGREEMENT FROM THE AGENT/OWNER OF THE LICENSED PREMISES TO SUSPEND OR RUN CONCURRENT WITH THE PERMANENT LICENSE DURING THE EVENT. IF THE SPECIAL EVENT IS ONLY USING A PORTION OF THE PREMISES, AGENT/OWNER WILL NEED TO SUSPEND THAT PORTION OF THE PREMISES.)

SECTION 8

What is the purpose of this event? On-site consumption Off-site (auction/wine/distilled spirits pull) Both

SECTION 9

1. Has the applicant been convicted of a felony, or had a liquor license revoked within the last five (5) years?
 Yes No (If yes, attach explanation.)
2. How many special event days have been issued to this organization during the calendar year? 1
(The number cannot exceed 10 days per year.)
3. Is the organization using the services of a promoter or other person to manage the sale or service of alcohol? Yes No
(If yes, must be a licensed contractor or licensee of series 6, 7, 11, or 12)
4. List all people and organizations who will receive the proceeds. Account for 100% of the proceeds. The organization applying must receive 25% of the gross revenues of the special event liquor sales. Attach an additional page if necessary.

Name	<u>City of San Luis Parks (Parks and Rec.)</u>	Percentage:	<u>25 %</u>
Address	<u>PO Box 1170 San Luis , Arizona 85349</u>		
Name	<u>San Luis Frontera Rotary</u>	Percentage:	<u>75%</u>
Address	<u>PO Box 13926</u>	<u>San Luis</u>	<u>Arizona 85349</u>
	<small>Street</small>	<small>City</small>	<small>State Zip</small>

Please read A.R.S. § 4-203.02 Special event license; rules and R19-1-205 Requirements for a Special Event License.

Note: ALL ALCOHOLIC BEVERAGE SALES MUST BE FOR CONSUMPTION AT THE EVENT SITE ONLY.

NO ALCOHOLIC BEVERAGES SHALL LEAVE A SPECIAL EVENT UNLESS THEY ARE IN AUCTION WINE OR DISTILLED SPIRITS PULL SEALED CONTAINERS OR THE SPECIAL EVENT LICENSE IS STACKED WITH WINE /CRAFT DISTILLERY FESTIVAL LICENSE.

5. What type of security and control measures will you take to prevent violations of liquor laws at this event?
(List type and number of police/security personnel and type of fencing or control barriers, if applicable.)
4 Number of Police 15 Number of Security Personnel Fencing Barriers
Explanation: Fencing and barricades will be placed around designated consumption areas. Entrance and exit will be posted.

SECTION 10 Dates and Hours of Event. Days must be consecutive but may not exceed 10 consecutive days. See A.R.S. § 4-244(15) and (17) for legal hours of service.

PLEASE FILL OUT A SEPARATE APPLICATION FOR EACH "NON-CONSECUTIVE" DAY

	Date	Day of Week	Event Start Time AM/PM	License End Time AM/PM
DAY 1:	July 4th,2019	Thursday	3:00 pm	1:30 am
DAY 2:	_____	_____	_____	_____
DAY 3:	_____	_____	_____	_____
DAY 4:	_____	_____	_____	_____
DAY 5:	_____	_____	_____	_____
DAY 6:	_____	_____	_____	_____
DAY 7:	_____	_____	_____	_____
DAY 8:	_____	_____	_____	_____
DAY 9:	_____	_____	_____	_____
DAY10:	_____	_____	_____	_____

SECTION 11 License premises diagram. The licensed premises for your special event is the area in which you are authorized to sell, dispense or serve alcoholic beverages under the provisions of your license. Please attach a diagram of your special event licensed premises. Please show dimensions, serving areas, fencing, barricades, or other control measures and security position.



Please contact the local governing board for additional application requirements and submission deadlines. Additional licensing fees may also be required before approval may be granted. For more information, please contact your local jurisdiction.

SECTION 12 Local Governing Body Approval Section.

Date Received: _____			
I, _____ (Government Official)	_____ (Title)	recommend	<input type="checkbox"/> APPROVAL <input type="checkbox"/> DISAPPROVAL
On behalf of _____ (City, Town, County)	_____ Signature	_____ Date	_____ Phone

SECTION 13 For Department of Liquor Licenses and Control use only.

<input type="checkbox"/> APPROVAL <input type="checkbox"/> DISAPPROVAL	BY: _____	DATE: ____/____/____
--	-----------	----------------------

A.R.S. § 41-1030. Invalidity of rules not made according to this chapter; prohibited agency action; prohibited acts by state employees; enforcement; notice

B. An agency shall not base a licensing decision in whole or in part on a licensing requirement or condition that is not specifically authorized by statute, rule or state tribal gaming compact. A general grant of authority in statute does not constitute a basis for imposing a licensing requirement or condition unless a rule is made pursuant to that general grant of authority that specifically authorizes the requirement or condition.

D. THIS SECTION MAY BE ENFORCED IN A PRIVATE CIVIL ACTION AND RELIEF MAY BE AWARDED AGAINST THE STATE. THE COURT MAY AWARD REASONABLE ATTORNEY FEES, DAMAGES AND ALL FEES ASSOCIATED WITH THE LICENSE APPLICATION TO A PARTY THAT PREVAILS IN AN ACTION AGAINST THE STATE FOR A VIOLATION OF THIS SECTION.

E. A STATE EMPLOYEE MAY NOT INTENTIONALLY OR KNOWINGLY VIOLATE THIS SECTION. A VIOLATION OF THIS SECTION IS CAUSE FOR DISCIPLINARY ACTION OR DISMISSAL PURSUANT TO THE AGENCY'S ADOPTED PERSONNEL POLICY.

F. THIS SECTION DOES NOT ABROGATE THE IMMUNITY PROVIDED BY SECTION 12-820.01 OR 12-820.02.

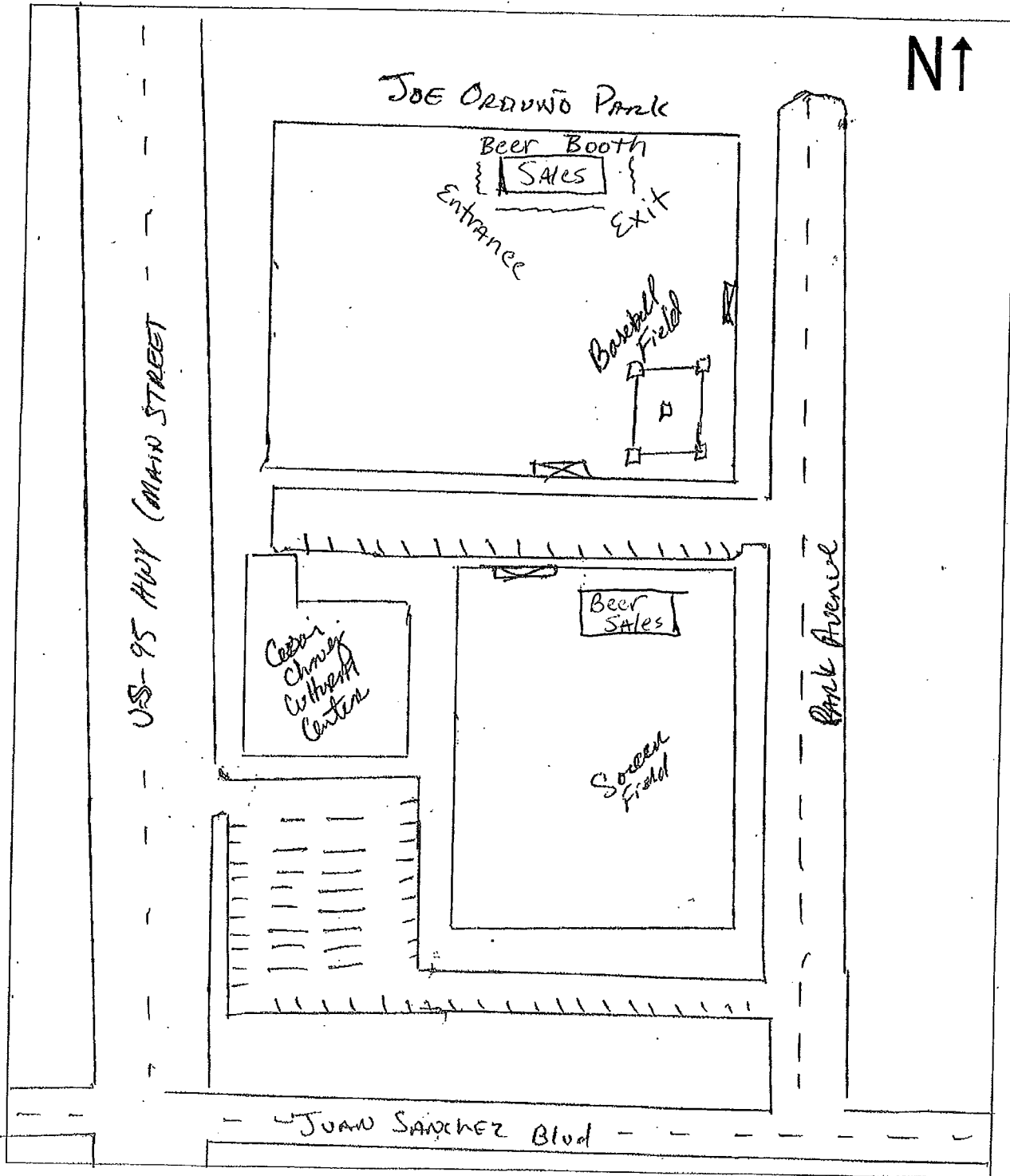

JOE ORDUNO PARK

N↑

US-95 HWY (MAIN STREET)

Park Avenue

Cesar Chavez Cultural Center

Beer Booth
SALES
Entrance Exit

Baseball Field

Beer Sales

Soccer Field

JUAN SANCHEZ Blvd

- Fencing



AGENDA ITEM REVIEW FORM

Regular City Council Meeting

6.D.

Meeting Date: 05/22/2019

Department Head: Kay Macuil, City Attorney, Attorney's Office

Submitted By: Kay Macuil, City Attorney, Attorney's Office

Action Requested: Motion
Order

ITEM:

Discussion and possible action on any and all matters regarding Order No. 2019-5. An order of the Mayor and City Council of the City of San Luis, Arizona implementing a uniform video and cable service license, a standard form application with an affidavit by mandate of the Arizona Legislature. **(Kay Marion Macuil, City Attorney)**

SUMMARY:

On May 16, 2018, Governor Ducey of Arizona signed into law SB1140 which requires that cities adopt by July 1, 2019, a uniform video and cable service license agreement along with a standard application and affidavit to obtain the license agreement. A telecommunications work-group developed the forms staff has provided for adoption. The cable industry has accepted them. The forms track SB1140, and they take into account HB2229 and HB2179 passed in April and May this year.

For more information, staff has attached an article and excerpts of two (2) reports by the League of Arizona Cities and Towns further explaining the law and the three (3) bills involved.

RECOMMENDATION / SUGGESTED MOTION:

I MOVE TO APPROVE AND ADOPT ORDER NO. 2019-5.

N/A

Fiscal Impact

IS THERE FISCAL IMPACT ASSOCIATED WITH THIS ITEM: No

CITY/STATE/FEDERAL FUNDS: N/A

TOTAL: N/A

BUDGETED AMOUNT: N/A

AVAILABLE AMOUNT TO TRANSFER: N/A

ACCT NAME & GL#/REMAINING BALANCE BEFORE PURCHASE: N/A

FISCAL IMPACT STATEMENT (IF THIS IS A BUDGET TRANSFER, YOU MUST ATTACH THE BUDGET ADJUSTMENT FORM):

There is no discernible fiscal impact. There will be only an administrative change.

Attachments

Order No. 2019-5

Model Cable Service Agreement
Standard Application & Affidavit for Agreement
League Article
League 2018 New Law Report
League 2019 New Laws & Implementation
SB1140
HB2229
HB 2179



Order

OFFICE OF THE
MAYOR
CITY OF SAN LUIS

No. 2019-5

AN ORDER OF THE MAYOR AND CITY COUNCIL OF THE CITY OF SAN LUIS, ARIZONA IMPLEMENTING A UNIFORM VIDEO AND CABLE SERVICE LICENSE, A STANDARD FORM APPLICATION WITH AN AFFIDAVIT BY MANDATE OF THE ARIZONA LEGISLATURE.

IT IS ORDERED by the Mayor and City Council of the City of San Luis, Arizona, as follows:

Section 1. Under SB1140 signed into Arizona law on or about May 16, 2018, the City of San Luis shall implement the Model Uniform Video Service License Agreement and the standard Application and Affidavit for Uniform Video Service License which are attached to this order and incorporated into this order by this reference as though fully set forth again in full.

Section 2. The various city officers and employees are authorized and directed to perform all acts necessary or desirable to give effect to this order.

PASSED AND ADOPTED by the Mayor and City Council of the City of San Luis, Arizona this _____ day of May, 2019

Gerardo Sanchez, Mayor

ATTEST:

APPROVED AS TO FORM:

Sonia Cornelio, City Clerk

Kay Macuil, City Attorney

Model Uniform Video Service License Agreement
Date of Issuance: _____

This Uniform Video Service License Agreement (“License”) is made on the date of issuance hereof by and between the City of San Luis, an Arizona municipal corporation (“Licensor”) and _____, a _____ (“Licensee”).

WHEREAS, Licensee has filed a completed application and affidavit under Title 9, Chapter 13, Arizona Revised Statutes (“Licensing Statute”), for Licensor to issue a Uniform Video Service License to Licensee; and

WHEREAS, Licensee is authorized under the laws of the State of Arizona to provide Cable Service.

NOW THEREFORE, in consideration of the foregoing recitals, which are incorporated herein and the mutual covenants set forth herein, the Parties agree as follows:

1. Definitions. Capitalized terms that are not defined herein have the same meaning prescribed in the Licensing Statute, including A.R.S. Section 9-1401.

2. Licensee Information. The following appear on Exhibit A attached hereto and are incorporated herein by this reference:

2.1 The name of Licensee, its type of entity and its jurisdiction of formation.

2.2 The address and telephone number of Licensee’s principal place of business.

2.3 The names, titles and addresses of Licensee’s principal executive officers or general partners.

2.4 The names, titles, telephone and fax numbers and email addresses of any persons authorized to represent Licensee before Licensor.

3. Grant of License. Under the Licensing Statute, Licensor hereby issues to Licensee, and Licensee hereby accepts from Licensor, a nonexclusive Uniform Video Service License.

3.1 The Service Area in which this License authorizes Licensee to provide Video Service in the area described on Exhibit B attached hereto and incorporated herein by this reference.

3.2. Licensor grants Licensee authority in the delivery of Video Service to use and occupy, and to construct and operate a Video Service Network in, Highways in the Service Area in compliance with the Licensing Statute and this License .

3.3 Licensee may operate and maintain facilities installed in the Highways in the Service Area to provide services pursuant to and subject to all the following: A.R.S. Section 9-584 and A.R.S. Title 9, Chapter 5.

4. Licensee Compliance with Law. Licensee shall comply with and be subject to:

4.1 All valid and enforceable federal and state laws.

4.2 All generally applicable, nondiscriminatory Local Laws, including highway use, mapping, insurance, performance bonds, security fund, indemnification, letter of credit or similar requirements that apply to the use and occupation of any highway and that conform to the Licensing Statute.

4.3 All public, education and government programming requirements of the Licensing Statute.

4.4 All customer service rules of the Federal Communications Commission under 47 Code of Federal Regulations Section 76.309(c) applicable to Cable Operators.

4.5 All consumer privacy requirements of 47 United States Code Section 551 applicable to Cable Operators.

5. Commencement of Video Service; Revocation. If Licensee is an incumbent cable operator, Licensee shall begin to provide Video Services under this License on the date of issuance of this license. If Licensee is not an incumbent cable operator, Licensee shall provide video service to at least one subscriber within each service area authorized by this License not later than twenty-four months after the date of issuance of this License. Failure of a non-incumbent cable operator to provide video service to at least one subscriber within each service area as set forth above shall result in revocation of this License unless the Licensee establishes to the satisfaction of the City/Town that such failure was for reasons beyond the Licensee's control.

6. License Fee. Licensee is required to pay the License Fees required under the Licensing Statute and all other lawful fees, taxes and charges imposed by Licensor. The initial rate of the License Fee shall be [five (5)] percent.

7. Federal Filing Requirement. Licensee is required to file in a timely manner with the Federal Communications Commission all forms required by that agency before Licensee offers Video Service in the Service Area, including the forms required by 47 Code of Federal Regulations Section 76.1801.

8. Term. The term of this License is ten (10) years and shall begin on the date of issuance.

STATE OF ARIZONA)
) ss.
County of Yuma)

The foregoing instrument was acknowledged before me this _____ day
of _____, 20__ by _____, Mayor of the City of San Luis, an
Arizona municipal corporation, on its behalf.

(Seal)

EXHIBIT A

[Information about Licensee]

I. Licensee:

Date:		
Applicant's Name:		
Principal Place of Business		
Phone:	Address:	
City:	State:	Zip:
Type of Entity:	Jurisdiction of Formation:	Email:

II. Licensee's principal executive officers or general partners:

Name:	Title:
Address:	

Name:	Title:
Address:	

Name:	Title:
Address:	

Name:	Title:
Address:	

III. Person(s) authorized to represent Licensee before Local Government:

Name:	Title:	
Address:		
Phone:	Fax:	Email:

Name:	Title:	
Address:		
Phone:	Fax:	Email:

Name:	Title:	
Address:		
Phone:	Fax:	Email:

EXHIBIT B
[Service Area]

APPLICATION AND AFFIDAVIT FOR UNIFORM VIDEO SERVICE LICENSE
(Pursuant to Title 9, chapter 13, Arizona Revised Statutes)

Local Government: City of San Luis

I. Applicant:

Date:		
Applicant's Name:		
Principal Place of Business:		
Phone:	Address:	
City/Town:	State:	Zip:
Type of Entity:	Jurisdiction of Formation:	Email:

II. Applicant's principal executive officers or general partners:

Name:	Title:
Address:	

Name:	Title:
Address:	

Name:	Title:
Address:	

Name:	Title:
Address:	

III. Person(s) authorized to represent Applicant before Local Government:

Name:	Title:	
Address:		
Phone:	Fax:	Email:

Name:	Title:	
Address:		
Phone:	Fax:	Email:

IV. Check one pursuant to Arizona Revised Statutes Section 9-1411(C)(4):

- Applicant is an Incumbent Cable Operator as provided in Arizona Revised Statutes, Section 9-1401(13).
- Applicant is not an Incumbent Cable Operator. The date on which the Applicant expects to provide Video Services in the Service Area identified below under Section 9-1411(C)(5) is:

Date:

V. For All Applications:

- A. Applicant will timely file with the Federal Communications Commission all forms required by that agency before Applicant offers Video Service in the Service Area, including the forms required by 47 Code of Federal Regulations Section 76.1801.
- B. The term of the uniform video service license shall be (not to exceed ten years):

Years

- C. Applicant agrees to pay all lawful fees and charges imposed by Local Government as provided in Arizona Revised Statutes, Section 9-1414(B)(4).
- D. Applicant agrees to notify Local Government in writing of changes to the above information within thirty days after the change occurs as provided in Arizona Revised Statutes, Section 9-1414(B)(2).
- E. Provide an exact description of the Service Area as set forth in Arizona Revised Statutes, Section 9-1411(C)(5), as identified by a geographic information system digital boundary meeting or exceeding national map accuracy standards.

Select one:

The Service Area consists of all the territory within the Boundaries of Local Government:

The Service Area consists of all the territory within the area described on attached Exhibit A.

Applicant Verification

I certify that the information contained in this application for a video service license in the [City/Town] of _____ is true and correct. I further affirm that I am authorized by _____ [NAME OF APPLICANT] to file this application on behalf of applicant and to bind the applicant with respect to the representations made in Section V, Paragraphs A through D of this application. A copy of the authorization is attached to this application.

<i>Name and Title (printed):</i>	
<i>Signature:</i>	<i>Date:</i>

Local Government Receipt

The foregoing Application and Affidavit for Uniform Video Service License was received by Local Government this ____ day of _____, 20__; at _____.

City of San Luis, an Arizona municipal corporation (“Local Government”)

By

Print Name

Title

Address

City, State, Zip

Phone

Fax

Email

Date

AZ LEAGUE CONNECTION



The League's Monthly Online Newsletter

Issue 192: April 2019

League News

[2019 League Annual Conference](#) ([league-annual-conference.html](#))

[League Conference Sponsorship](#) ([league-corporate-sponsorship.html](#))

[Service Award List](#) ([league-service-awards.html](#))

[Municipal Clerks Week: May 5 – 11, 2019](#) ([municipal-clerks-week.html](#))

[League Publications](#) ([league-publications.html](#))

[Arizona City and Town Hall](#) ([city-town.html](#))

[Municipal Grants Training](#) ([league-training.html](#))

Other News

[Six Ways to Connect Across Divides](#) ([6-ways-connect-across-divides.html](#))

[HUD Announces Request for Information on](#)



Legal Corner: Video Services Update

In 2018, the Legislature enacted uniform video service license legislation that requires cities and towns to adopt a standard uniform video service license agreement and application for the uniform license by July 1, 2019. This article provides a review of those provisions of the legislation and an update on the form templates that can be used by cities and towns.

[Senate Bill 1140](#)

(<https://www.azleg.gov/legtext/53leg/2R/laws/0331.htm>) (Laws 2018, Ch. 331) preempts city and town regulation of the licensing of video service providers and the use of video service. The legislation mandated that cities and towns issue uniform video service licenses to video service providers beginning [July 1, 2019](#). Municipalities are required to adopt a standard license agreement and a standard form of application and affidavit signed by one of the principal executive officers or general partners of the applicant. A video service provider

[Maximizing the Positive Impact of Opportunity Zones \(affordable-housing.html\)](#)

Legal Corner

[Video Services Update \(legal-corner.html\)](#)

Upcoming Trainings & Events

[2019 ACAA Summer Conference \(training-events.html#event-1\)](#)
[Trends in Affordable and Workforce Housing: Adapting Best Practices to Arizona \(training-events.html#event-2\)](#)
[Arizona Women Leading Government Conference \(training-events.html#event-3\)](#)
[ACMA Summer Conference \(training-events.html#event-4\)](#)

Throwback

[51 Years Ago \(throwback.html#throwback1\)](#)
[143 Years Ago \(throwback.html#throwback2\)](#)



Calendar of Events

[\(http://www.azleague.org/calendar.aspx\)](http://www.azleague.org/calendar.aspx)



means any person that provides or offers to provide video service over a video service network to subscribers in Arizona and includes incumbent cable operators (those already providing video service in Arizona through a local license on December 31, 2019 who choose to terminate the local license). [A.R.S. § 9-1401 \(https://www.azleg.gov/viewdocument/?docName=https://www.azleg.gov/ars/9/01401.htm\)](https://www.azleg.gov/viewdocument/?docName=https://www.azleg.gov/ars/9/01401.htm).

Incumbent Cable Operators and Holdover Cable Operators

From January 1, 2020 until June 30, 2020, incumbent cable operators may elect to continue to operate pursuant to the local license or terminate the local license and apply for a uniform video service license. If the incumbent cable operator obtains a uniform video service license, the local license is terminated when the uniform license is issued and the operator operates within the service area defined in the local license. [A.R.S. § 9-1412 \(https://www.azleg.gov/viewdocument/?docName=https://www.azleg.gov/ars/9/01412.htm\)](https://www.azleg.gov/viewdocument/?docName=https://www.azleg.gov/ars/9/01412.htm). If the operator does not timely elect to terminate a local license, the person continues to operate the cable system as a holdover cable operator pursuant to the local license. [A.R.S. § 9-1413 \(https://www.azleg.gov/viewdocument/?docName=https://www.azleg.gov/ars/9/01413.htm\)](https://www.azleg.gov/viewdocument/?docName=https://www.azleg.gov/ars/9/01413.htm). Following the natural termination of the local license, the holdover cable operator must apply for a uniform video service license at least one month prior to the expiration of the local license.

Application and Affidavit Requirements

The legislation requires the application and affidavit to include the service area, the uniform license agreement provisions, the term of the license, and an agreement to pay any fees and charges. The application and affidavit must be filed with the municipal clerk and must contain the service area where the applicant intends to provide video service, contact information and the date when service will begin (if not an incumbent provider), the term of the license, and an agreement to pay all

Municipal Employment Opportunities

(<http://www.azleague.org/jobs.aspx>)



(<http://azcitieswork.com/>)

lawful fees and charges imposed by the municipality. It is important for your clerk to know the appropriate individual in your city or town who processes the application and affidavit since the city or town has only fifteen business days to make an initial determination and reject the application and affidavit if incomplete or otherwise deficient (by written notice). A.R.S. § 9-1414 (<https://www.azleg.gov/viewdocument/?docName=https://www.azleg.gov/ars/9/01414.htm>).

Uniform Video Service License Agreement

The uniform video services license agreement contains sixteen separate provisions including the date on which the provider expects to provide video services in the area, a description of the service area to be served, a requirement that the provider will pay the license fees and all other lawful charges imposed by cities and towns, and requirements that the provider comply with federal, state and local laws, consumer privacy mandates and public, education and government programming requirements. A.R.S § 9-1411 (<https://www.azleg.gov/viewdocument/?docName=https://www.azleg.gov/ars/9/01411.htm>). The city or town must issue the uniform license to the applicant thirty days after the filing of a completed application and affidavit. A.R.S § 9-1415 (<https://www.azleg.gov/viewdocument/?docName=https://www.azleg.gov/ars/9/01415.htm>).

Conclusion

This article focused on the initial licensing process and the required forms each city and town must utilize to implement the uniform video services legislation. For more information on other provisions of the legislation relating to right-of-way management, appeals process, termination or transfer of licenses, and fee limitations, please see the 2018 League New Laws summary.

(<http://www.azleague.org/ArchiveCenter/ViewFile/Item/338>),

(page 14) or [SB1140](#)

(<https://www.azleg.gov/legtext/53leg/2R/laws/0331.htm>).

The Telecommunications Workgroup has drafted a model video services license agreement and application and affidavit with the assistance of stakeholders and the cable industry. These forms were distributed to all municipal attorneys last week and are available here:

[Video Services Application and Affidavit](#)

(<http://azleague.org/DocumentCenter/View/10922>)

[Video Services License Agreement](#)

(<http://www.azleague.org/documentcenter/view/10921>)

azleague.org

(<http://www.azleague.org>)

Follow us: 

(<https://www.facebook.com/AZCities/>)



(<https://twitter.com/azcities>)



(https://www.youtube.com/channel/UCJSFxFYlrzLo6_YPRT4E1wMQ)



(<https://www.instagram.com/azcities/>)

**League of Arizona Cities
and Towns**

1820 W Washington Street

Phoenix, AZ 85007

Phone: 602-258-5786

Fax: 602-253-3874

Email:

newsletter@azleague.org

(<mailto:newsletter@azleague.org>)



Introduction

Welcome to the *2018 New Laws Report of the League of Arizona Cities and Towns*. The Report is designed to serve as a guide to those enactments of the second regular session of the 53rd Arizona Legislature that have demonstrable impacts on municipalities.

During the past session, 1,206 bills were introduced in the House and Senate. Of these, 370 passed the legislature (369 in Regular Session and one enacted in a Special Session) and were sent to the Governor, and 346 were signed into law. Almost 23% of these enactments affect cities and towns and are summarized in the Report.

Scope and Use

This Report is intended only to identify and summarize those new laws with significant impacts on Arizona municipalities. It does not describe every provision of every law in detail, but it does provide a hyperlink to the chaptered version of each law summarized. To gain a better understanding of the new laws, readers are encouraged to review the exact language of their provisions as well as relevant legislative history. For those new enactments that modify current law, the Report makes no effort to describe the underlying law other than to provide sufficient context for an understanding of the statutory modification. Furthermore, the Report focuses on only those new laws that have broad statewide applicability to cities and towns.

Effective Dates

Unless otherwise noted, the effective date of the new laws described in the Report is August 3, 2018. This date – 90 days after the conclusion of the legislative session – is the general effective date for all enactments that are passed without an emergency clause or alternative effective date. The Report does endeavor to identify effective dates that vary from the general effective date. Where appropriate, it also includes other statutory dates, such as repeal dates, implementation dates and deadlines.

Disclaimers

The Report, published as a service to the members of the League of Arizona Cities and Towns, does not necessarily identify every law with impacts on municipalities. It is neither designed nor intended to provide legal advice or counsel. It should be relied upon only as a reference tool and not as a comprehensive guidance document. In certain limited instances, the Report does highlight action items that should be considered by cities and towns. In no case, however, should the Report substitute for the independent judgment of your city or town manager or attorney.

Part Four

General Government

SB 1042 (backflow prevention; state fire code)

([Chapter 19](#))

Requires backflow prevention equipment on class 1 or class 2 fire protection systems to be approved, inspected and maintained in accordance with the state fire code, instead of a National Fire Protection Association publication or the uniform fire code.

SB 1111 (workers' compensation; opioids; dispensed medications)

([Chapter 101](#))

Requires a physician that prescribes a narcotic or opium-based controlled substance listed in Schedule II or a prescription of any opioid medication that is given to an employee to include in the report to the Industrial Commission documentation that a physical examination of the employee was conducted, that a substance use risk assessment of the employee was completed and that the employee gave informed consent for any opioid treatment. Requires the treatment plan for these medications to include face-to-face follow up visits to reevaluate the employee's continued use of opioids, criteria and procedures for tapering and discontinuing opioid prescription or administration and criteria and procedures for offering or referring the employee for treatment for dependence on or addiction to opioids. Requires the physician to obtain a patient utilization report regarding the employee from the controlled substances prescription monitoring program's central database tracking system before prescribing an opioid analgesic or benzodiazepine controlled substance that is listed in schedule II, III or IV and at least quarterly while that prescription remains a part of the treatment. Requires the Industrial Commission to review information and data, consult with stakeholders and hold at least one public hearing by July 1, 2019 in considering whether to adopt additional reimbursement guidelines for medications dispensed in settings that are not accessible to the general public.

SB 1140 (certificates of authority; video service)

([Chapter 331](#))

Establishes a uniform video service license, issued by cities, towns and counties, and allows cable companies to terminate existing cable franchise license agreements for the uniform license after January 1, 2020. Requires cities and towns to adopt a standard uniform video service license agreement and application for the uniform license by July 1, 2019. Prohibits local regulation of video service providers or their networks beyond requirements related to license issuance and right-of-way management; build-out, line extension or other requirements related to infrastructure, facilities and deployment of equipment are also prohibited. Requires the Office of Administrative Hearings to oversee license-related disputes, including disputes regarding under or overpayment of license fees. Specifies requirements for license fee audits and allocation of bundling discounts and requirements for video service providers to add or terminate service territories and extend or transfer a video service license. PEG channel capacity is limited to four - two channels in the basic tier and two channels in the digital tier; or two lines of programming in standard definition and two in switched digital. Cities and towns are prohibited from charging a filing or processing fee for and from taking any official action on the application to receive a video service license.



Introduction

Welcome to the *2018 New Laws Report of the League of Arizona Cities and Towns*. The Report is designed to serve as a guide to those enactments of the second regular session of the 53rd Arizona Legislature that have demonstrable impacts on municipalities.

During the past session, 1,206 bills were introduced in the House and Senate. Of these, 370 passed the legislature (369 in Regular Session and one enacted in a Special Session) and were sent to the Governor, and 346 were signed into law. Almost 23% of these enactments affect cities and towns and are summarized in the Report.

Scope and Use

This Report is intended only to identify and summarize those new laws with significant impacts on Arizona municipalities. It does not describe every provision of every law in detail, but it does provide a hyperlink to the chaptered version of each law summarized. To gain a better understanding of the new laws, readers are encouraged to review the exact language of their provisions as well as relevant legislative history. For those new enactments that modify current law, the Report makes no effort to describe the underlying law other than to provide sufficient context for an understanding of the statutory modification. Furthermore, the Report focuses on only those new laws that have broad statewide applicability to cities and towns.

Effective Dates

Unless otherwise noted, the effective date of the new laws described in the Report is August 3, 2018. This date – 90 days after the conclusion of the legislative session – is the general effective date for all enactments that are passed without an emergency clause or alternative effective date. The Report does endeavor to identify effective dates that vary from the general effective date. Where appropriate, it also includes other statutory dates, such as repeal dates, implementation dates and deadlines.

Disclaimers

The Report, published as a service to the members of the League of Arizona Cities and Towns, does not necessarily identify every law with impacts on municipalities. It is neither designed nor intended to provide legal advice or counsel. It should be relied upon only as a reference tool and not as a comprehensive guidance document. In certain limited instances, the Report does highlight action items that should be considered by cities and towns. In no case, however, should the Report substitute for the independent judgment of your city or town manager or attorney.

Part Four

General Government

SB 1042 (backflow prevention; state fire code)

([Chapter 19](#))

Requires backflow prevention equipment on class 1 or class 2 fire protection systems to be approved, inspected and maintained in accordance with the state fire code, instead of a National Fire Protection Association publication or the uniform fire code.

SB 1111 (workers' compensation; opioids; dispensed medications)

([Chapter 101](#))

Requires a physician that prescribes a narcotic or opium-based controlled substance listed in Schedule II or a prescription of any opioid medication that is given to an employee to include in the report to the Industrial Commission documentation that a physical examination of the employee was conducted, that a substance use risk assessment of the employee was completed and that the employee gave informed consent for any opioid treatment. Requires the treatment plan for these medications to include face-to-face follow up visits to reevaluate the employee's continued use of opioids, criteria and procedures for tapering and discontinuing opioid prescription or administration and criteria and procedures for offering or referring the employee for treatment for dependence on or addiction to opioids. Requires the physician to obtain a patient utilization report regarding the employee from the controlled substances prescription monitoring program's central database tracking system before prescribing an opioid analgesic or benzodiazepine controlled substance that is listed in schedule II, III or IV and at least quarterly while that prescription remains a part of the treatment. Requires the Industrial Commission to review information and data, consult with stakeholders and hold at least one public hearing by July 1, 2019 in considering whether to adopt additional reimbursement guidelines for medications dispensed in settings that are not accessible to the general public.

SB 1140 (certificates of authority; video service)

([Chapter 331](#))

Establishes a uniform video service license, issued by cities, towns and counties, and allows cable companies to terminate existing cable franchise license agreements for the uniform license after January 1, 2020. Requires cities and towns to adopt a standard uniform video service license agreement and application for the uniform license by July 1, 2019. Prohibits local regulation of video service providers or their networks beyond requirements related to license issuance and right-of-way management; build-out, line extension or other requirements related to infrastructure, facilities and deployment of equipment are also prohibited. Requires the Office of Administrative Hearings to oversee license-related disputes, including disputes regarding under or overpayment of license fees. Specifies requirements for license fee audits and allocation of bundling discounts and requirements for video service providers to add or terminate service territories and extend or transfer a video service license. PEG channel capacity is limited to four - two channels in the basic tier and two channels in the digital tier; or two lines of programming in standard definition and two in switched digital. Cities and towns are prohibited from charging a filing or processing fee for and from taking any official action on the application to receive a video service license.

State of Arizona
Senate
Fifty-third Legislature
Second Regular Session
2018

CHAPTER 331
SENATE BILL 1140

AN ACT

AMENDING TITLE 9, ARIZONA REVISED STATUTES, BY ADDING CHAPTER 13; AMENDING SECTION 41-1092.01, ARIZONA REVISED STATUTES; RELATING TO VIDEO AND CABLE SERVICE PROVIDERS.

(TEXT OF BILL BEGINS ON NEXT PAGE)

1 Be it enacted by the Legislature of the State of Arizona:

2 Section 1. Title 9, Arizona Revised Statutes, is amended by adding
3 chapter 13, to read:

4 CHAPTER 13

5 VIDEO SERVICE

6 ARTICLE 1. GENERAL PROVISIONS

7 9-1401. Definitions

8 IN THIS CHAPTER, UNLESS THE CONTEXT OTHERWISE REQUIRES:

9 1. "AFFILIATE" MEANS A PERSON THAT DIRECTLY OR INDIRECTLY, THROUGH
10 ONE OR MORE INTERMEDIARIES, CONTROLS, IS CONTROLLED BY OR IS UNDER COMMON
11 CONTROL WITH A VIDEO SERVICE PROVIDER.

12 2. "AGREEMENT" MEANS ANY AGREEMENT OR CONTRACT.

13 3. "BOUNDARIES OF A LOCAL GOVERNMENT" OR "BOUNDARIES" MEANS:

14 (a) FOR A CITY OR TOWN, ALL OF THE AREA WITHIN THE CORPORATE LIMITS
15 OF THE CITY OR TOWN.

16 (b) FOR A COUNTY, ALL OF THE AREA OF THE COUNTY THAT IS NOT WITHIN
17 THE CORPORATE LIMITS OF ANY CITY OR TOWN, INCLUDING UNINCORPORATED
18 TERRITORY THAT IS SURROUNDED ON ALL SIDES BY A COMBINATION OF ONE OR MORE
19 CITIES, TOWNS OR INDIAN RESERVATIONS.

20 4. "CABLE OPERATOR" HAS THE SAME MEANING PRESCRIBED IN 47 UNITED
21 STATES CODE SECTION 522.

22 5. "CABLE SERVICE" HAS THE SAME MEANING PRESCRIBED IN 47 UNITED
23 STATES CODE SECTION 522.

24 6. "CABLE SYSTEM" HAS THE SAME MEANING PRESCRIBED IN 47 UNITED
25 STATES CODE SECTION 522.

26 7. "COMMERCIAL MOBILE SERVICE PROVIDER" MEANS A PERSON THAT
27 PROVIDES COMMERCIAL MOBILE SERVICE AS DEFINED IN 47 UNITED STATES CODE
28 SECTION 332(d) OR COMMERCIAL MOBILE RADIO SERVICE AS DESCRIBED IN 47 CODE
29 OF FEDERAL REGULATIONS SECTION 20.9.

30 8. "DAY" MEANS A CALENDAR DAY, EXCEPT A SATURDAY OR SUNDAY OR A
31 HOLIDAY PRESCRIBED IN SECTION 1-301.

32 9. "GROSS REVENUE":

33 (a) MEANS ALL CASH, CREDITS, PROPERTY OF ANY KIND OR NATURE OR
34 OTHER CONSIDERATION THAT IS RECEIVED DIRECTLY OR INDIRECTLY BY A VIDEO
35 SERVICE PROVIDER, ITS AFFILIATES, OR ANY PERSON, FIRM OR CORPORATION IN
36 WHICH THE VIDEO SERVICE PROVIDER HAS A FINANCIAL INTEREST OR THAT HAS A
37 FINANCIAL INTEREST IN THE VIDEO SERVICE PROVIDER AND THAT IS DERIVED FROM
38 THE VIDEO SERVICE PROVIDER'S OPERATION OF ITS VIDEO SERVICE NETWORK TO
39 PROVIDE VIDEO SERVICE IN THE SERVICE AREA.

40 (b) INCLUDES ALL REVENUE FROM CHARGES FOR VIDEO SERVICE TO
41 SUBSCRIBERS AND ALL CHARGES FOR INSTALLATION, REMOVAL, CONNECTION OR
42 REINSTATEMENT OF EQUIPMENT NECESSARY FOR A SUBSCRIBER TO RECEIVE VIDEO
43 SERVICE AND ANY OTHER RECEIPTS FROM SUBSCRIBERS DERIVED FROM THE VIDEO
44 SERVICE PROVIDER'S OPERATION OF THE VIDEO SERVICE NETWORK TO PROVIDE VIDEO
45 SERVICE, INCLUDING RECEIPTS FROM FORFEITED DEPOSITS, SALE OR RENTAL OF

1 EQUIPMENT TO PROVIDE VIDEO SERVICE, LATE CHARGES, INTEREST AND SALE OF
2 PROGRAM GUIDES.

3 (c) DOES NOT INCLUDE:

4 (i) ANY REVENUE NOT RECEIVED, EVEN IF BILLED, SUCH AS BAD DEBT NET
5 OF ANY RECOVERIES OF BAD DEBT OR ANY REFUNDS, CREDITS, ALLOWANCES OR
6 DISCOUNTS TO SUBSCRIBERS TO THE EXTENT THAT THE REFUND, REBATE, CREDIT,
7 ALLOWANCE OR DISCOUNT IS ATTRIBUTED TO VIDEO SERVICE.

8 (ii) REVENUE FROM COMMERCIAL ADVERTISING ON THE VIDEO SERVICE
9 NETWORK, THE USE OR LEASE OF STUDIO FACILITIES OF THE VIDEO SERVICE
10 NETWORK, INTERNET ACCESS SERVICE, THE USE OR LEASE OF ITS FACILITIES
11 LOCATED IN THE HIGHWAYS, THE USE OR LEASE OF LEASED ACCESS CHANNELS OR
12 BANDWIDTH, THE USE OR LEASE OF TOWERS, THE PRODUCTION OF VIDEO PROGRAMMING
13 BY THE VIDEO SERVICE PROVIDER, THE SALE, EXCHANGE, USE OR CABLECAST OF ANY
14 PROGRAMMING BY THE VIDEO SERVICE PROVIDER IN THE SERVICE AREA, SALES TO
15 THE VIDEO SERVICE PROVIDER'S SUBSCRIBERS BY PROGRAMMERS OF HOME SHOPPING
16 SERVICES, REIMBURSEMENTS PAID BY PROGRAMMERS FOR LAUNCH FEES OR MARKETING
17 EXPENSES, LICENSE FEES, TAXES OR OTHER FEES OR CHARGES THAT THE VIDEO
18 SERVICE PROVIDER COLLECTS AND PAYS TO ANY GOVERNMENTAL AUTHORITY, ANY
19 INCREASE IN THE VALUE OF ANY STOCK, SECURITY OR ASSET, OR ANY DIVIDENDS OR
20 OTHER DISTRIBUTIONS MADE FROM ANY STOCK OR SECURITIES.

21 10. "HIGHWAY" MEANS ALL ROADS, STREETS AND ALLEYS AND OTHER
22 DEDICATED PUBLIC RIGHTS-OF-WAY THAT ARE OPERATED AND MAINTAINED BY A LOCAL
23 GOVERNMENT.

24 11. "HOLDER" MEANS A VIDEO SERVICE PROVIDER THAT HAS BEEN ISSUED A
25 UNIFORM VIDEO SERVICE LICENSE PURSUANT TO THIS CHAPTER.

26 12. "HOLDOVER CABLE OPERATOR" MEANS AN INCUMBENT CABLE OPERATOR
27 THAT ELECTS UNDER SECTIONS 9-1412 AND 9-1413 TO CONTINUE TO OPERATE WITHIN
28 ITS SERVICE AREA PURSUANT TO ITS LOCAL LICENSE.

29 13. "INCUMBENT CABLE OPERATOR" MEANS A CABLE OPERATOR OR OTHER
30 VIDEO SERVICE PROVIDER THAT ON DECEMBER 31, 2019 IS PROVIDING VIDEO
31 SERVICE IN THIS STATE PURSUANT TO A LOCAL LICENSE.

32 14. "INFORMATION SERVICE" HAS THE SAME MEANING PRESCRIBED IN 47
33 UNITED STATES CODE SECTION 153.

34 15. "INTERACTIVE COMPUTER SERVICE" HAS THE SAME MEANING PRESCRIBED
35 IN 47 UNITED STATES CODE SECTION 230(f).

36 16. "LICENSE" MEANS A FRANCHISE AS DEFINED IN 47 UNITED STATES CODE
37 SECTION 522.

38 17. "LICENSE FEE" MEANS A LICENSE FEE IMPOSED BY A LOCAL GOVERNMENT
39 ON A VIDEO SERVICE PROVIDER FOR USING THE HIGHWAYS TO PROVIDE AND FOR THE
40 PRIVILEGE OF PROVIDING VIDEO SERVICE.

41 18. "LOCAL GOVERNMENT" MEANS ANY CITY, INCLUDING A CHARTER CITY,
42 TOWN OR COUNTY.

43 19. "LOCAL LAW" MEANS ANY CHARTER, CODE, ORDINANCE, RESOLUTION,
44 REGULATION OR OTHER LAW OF A LOCAL GOVERNMENT.

1 20. "LOCAL LICENSE" MEANS ANY LICENSE, AGREEMENT, PERMIT OR SIMILAR
2 AUTHORIZATION THAT MEETS ALL OF THE FOLLOWING:

3 (a) ALLOWS A PERSON TO CONSTRUCT OR OPERATE A VIDEO SERVICE NETWORK
4 WITHIN THE BOUNDARIES OF A LOCAL GOVERNMENT.

5 (b) IS ISSUED, GRANTED, APPROVED, EXTENDED OR RENEWED BY THE LOCAL
6 GOVERNMENT BEFORE JANUARY 1, 2020 PURSUANT TO THE AUTHORITY OF ANY
7 FEDERAL, STATE OR LOCAL LAW IN EFFECT AT THE TIME OF THE ISSUANCE, GRANT,
8 APPROVAL, EXTENSION OR RENEWAL.

9 (c) IS EFFECTIVE UNDER FEDERAL, STATE OR LOCAL LAW ON DECEMBER 31,
10 2019 FOR THE PERSON TO CONTINUE TO CONSTRUCT OR OPERATE A VIDEO SERVICE
11 NETWORK WITHIN THE BOUNDARIES OF A LOCAL GOVERNMENT.

12 21. "MULTICHANNEL VIDEO PROGRAMMING DISTRIBUTOR" HAS THE SAME
13 MEANING PRESCRIBED IN 47 UNITED STATES CODE SECTION 522.

14 22. "SERVICE AREA" MEANS THAT PART OF THE BOUNDARIES OF A LOCAL
15 GOVERNMENT WITHIN WHICH A VIDEO SERVICE PROVIDER IS AUTHORIZED TO PROVIDE
16 VIDEO SERVICE PURSUANT TO A UNIFORM VIDEO SERVICE LICENSE OR A LOCAL
17 LICENSE.

18 23. "SUBSCRIBER" MEANS ANY PERSON IN THIS STATE THAT PURCHASES
19 VIDEO SERVICE. SUBSCRIBER DOES NOT INCLUDE ANY PERSON THAT PURCHASES
20 VIDEO SERVICE FOR RESALE AND THAT, ON RESALE, IS REQUIRED TO PAY A LICENSE
21 FEE PURSUANT TO THIS CHAPTER OR THE TERMS OF A LOCAL LICENSE.

22 24. "TELECOMMUNICATIONS":

23 (a) MEANS THE TRANSMISSION, BETWEEN OR AMONG POINTS SPECIFIED BY
24 THE USER, OF INFORMATION OF THE USER'S CHOOSING, WITHOUT CHANGE IN THE
25 FORM OR CONTENT OF THE INFORMATION SENT AND RECEIVED, REGARDLESS OF THE
26 FACILITIES, EQUIPMENT OR TECHNOLOGY USED.

27 (b) DOES NOT INCLUDE COMMERCIAL MOBILE RADIO SERVICE, PAY PHONE
28 SERVICE, INTERSTATE SERVICE OR CABLE SERVICE.

29 25. "TELECOMMUNICATIONS PROVIDER" MEANS A PERSON THAT IS REQUIRED
30 TO OBTAIN FROM THE CORPORATION COMMISSION A CERTIFICATE OF PUBLIC
31 CONVENIENCE AND NECESSITY TO PROVIDE TELECOMMUNICATIONS SERVICE.

32 26. "TELECOMMUNICATIONS SERVICE" MEANS THE OFFERING OF
33 TELECOMMUNICATIONS FOR A FEE DIRECTLY TO THE PUBLIC, OR TO SUCH USERS AS
34 TO BE EFFECTIVELY AVAILABLE DIRECTLY TO THE PUBLIC, REGARDLESS OF THE
35 EQUIPMENT, FACILITIES OR TECHNOLOGY USED.

36 27. "UNIFORM VIDEO SERVICE LICENSE" MEANS A LICENSE THAT IS ISSUED
37 BY A LOCAL GOVERNMENT IN THE FORM OF A UNIFORM VIDEO SERVICE LICENSE
38 AGREEMENT AS ADOPTED PURSUANT TO SECTION 9-1411.

39 28. "VIDEO SERVICE":

40 (a) MEANS THE PROVISION OF MULTICHANNEL VIDEO PROGRAMMING GENERALLY
41 CONSIDERED COMPARABLE TO VIDEO PROGRAMMING DELIVERED BY A TELEVISION
42 BROADCAST STATION, VIDEO SERVICE OR OTHER DIGITAL TELEVISION SERVICE,
43 WHETHER PROVIDED AS PART OF A TIER, ON DEMAND OR ON A PER-CHANNEL BASIS,
44 WITHOUT REGARD TO THE TECHNOLOGY USED TO DELIVER THE VIDEO SERVICE,
45 INCLUDING INTERNET PROTOCOL TECHNOLOGY OR ANY SUCCESSOR TECHNOLOGY.

1 (b) INCLUDES CABLE SERVICE.

2 (c) DOES NOT INCLUDE ANY OF THE FOLLOWING:

3 (i) VIDEO PROGRAMMING PROVIDED SOLELY AS PART OF, AND THROUGH, A
4 SERVICE THAT ENABLES USERS TO ACCESS CONTENT, INFORMATION, E-MAIL,
5 MESSAGING OR OTHER SERVICES THAT ARE OFFERED VIA THE PUBLIC INTERNET.

6 (ii) DIRECT BROADCAST SATELLITE SERVICE.

7 (iii) WIRELESS MULTICHANNEL VIDEO PROGRAMMING THAT IS PROVIDED BY A
8 COMMERCIAL MOBILE SERVICE PROVIDER.

9 29. "VIDEO SERVICE NETWORK":

10 (a) MEANS A WIRELINE NETWORK, OR ANY COMPONENT OF A WIRELINE
11 NETWORK, THAT IS LOCATED IN THIS STATE, CONSTRUCTED IN WHOLE OR IN PART
12 IN, ON, UNDER OR OVER ANY HIGHWAY AND USED TO PROVIDE VIDEO SERVICE.

13 (b) INCLUDES A CABLE SYSTEM.

14 30. "VIDEO SERVICE PROVIDER":

15 (a) MEANS ANY PERSON THAT PROVIDES OR OFFERS TO PROVIDE VIDEO
16 SERVICE OVER A VIDEO SERVICE NETWORK TO SUBSCRIBERS IN THIS STATE.

17 (b) INCLUDES AN INCUMBENT CABLE OPERATOR THAT ELECTED PURSUANT TO
18 SECTIONS 9-1412 AND 9-1413 TO TERMINATE ITS LOCAL LICENSE AND A
19 MULTICHANNEL VIDEO PROGRAMMING DISTRIBUTOR.

20 (c) DOES NOT INCLUDE A HOLDOVER CABLE OPERATOR.

21 9-1402. State preemption; uniform regulation and licensing

22 A. THE LICENSING OF VIDEO SERVICE PROVIDERS AND THE REGULATION AND
23 USE OF VIDEO SERVICE ARE MATTERS OF STATEWIDE CONCERN. EXCEPT AS PROVIDED
24 IN THIS CHAPTER, THE LICENSING OF VIDEO SERVICE PROVIDERS AND THE
25 REGULATION AND USE OF VIDEO SERVICE ARE NOT SUBJECT TO FURTHER REGULATION
26 BY A LOCAL GOVERNMENT. THE REGULATION OF VIDEO SERVICE PURSUANT TO THIS
27 CHAPTER, INCLUDING APPLICATION TO THE LOCAL LICENSES OF INCUMBENT CABLE
28 OPERATORS, IS REASONABLE AND NECESSARY TO PROMOTE ALL OF THE FOLLOWING:

29 1. PROVISION OF COMPETITIVE VIDEO, TELECOMMUNICATIONS AND
30 INFORMATION SERVICE THROUGHOUT THIS STATE.

31 2. MORE UNIFORM REGULATION OF COMPETITIVE VIDEO SERVICE THROUGHOUT
32 THIS STATE.

33 3. STREAMLINED LICENSING BY LOCAL GOVERNMENTS AND MORE UNIFORM
34 TERMS AND CONDITIONS FOR VIDEO SERVICE PROVIDERS THAT USE HIGHWAYS TO
35 PROVIDE VIDEO AND OTHER SERVICES OVER VIDEO SERVICE NETWORKS.

36 4. CONTINUED MANAGEMENT BY LOCAL GOVERNMENTS OF USE OF THEIR
37 HIGHWAYS WITH REASONABLE BURDENS ON CONSTRUCTION AND MAINTENANCE ACROSS
38 BOUNDARIES BETWEEN LOCAL GOVERNMENTS FOR VIDEO SERVICE PROVIDERS TO USE
39 HIGHWAYS TO PROVIDE VIDEO AND OTHER SERVICES OVER VIDEO SERVICE NETWORKS.

40 5. CONTINUED LEVYING OF LICENSE FEES BY LOCAL GOVERNMENTS ON
41 SUBSCRIBER SERVICE REVENUES DERIVED FROM OPERATING VIDEO SERVICE NETWORKS
42 TO PROVIDE VIDEO SERVICE.

43 6. SUPPORT FOR FEDERAL SUBSCRIBER SERVICE STANDARDS.

44 B. TO THE FULLEST EXTENT ALLOWED BY FEDERAL LAW, THIS CHAPTER
45 OCCUPIES THE ENTIRE FIELD OF LICENSING AND REGULATION OF VIDEO SERVICE.

1 C. EXCEPT AS OTHERWISE PROVIDED IN THIS CHAPTER, FROM AND AFTER
2 DECEMBER 31, 2019 THIS CHAPTER PREEMPTS AND LIMITS THE ABILITY OF A LOCAL
3 GOVERNMENT TO REGULATE OR ENFORCE ALL OF THE FOLLOWING:

4 1. THE APPLICATION OF CHAPTER 5, ARTICLE 1.1 OF THIS TITLE TO VIDEO
5 SERVICE PROVIDERS.

6 2. ANY LOCAL LAW AND ANY AGREEMENT WITH A LOCAL GOVERNMENT THAT
7 DOES ANY OF THE FOLLOWING:

8 (a) REQUIRES A PERSON OTHER THAN A HOLDOVER CABLE OPERATOR TO
9 OBTAIN OR HOLD FROM A LOCAL GOVERNMENT ANY LICENSE, PERMIT OR SIMILAR
10 AUTHORIZATION THAT IS A PREREQUISITE TO PROVIDING VIDEO SERVICE OR TO
11 CONSTRUCTING, MAINTAINING OR USING THE HIGHWAYS TO OPERATE A VIDEO SERVICE
12 NETWORK IN THE HIGHWAYS WITHIN ITS BOUNDARIES.

13 (b) REGULATES THE PROVISION OF VIDEO SERVICE OR THE CONSTRUCTION OR
14 OPERATION OF A VIDEO SERVICE NETWORK IF THE LOCAL LAW DOES NOT CONFORM TO
15 THIS CHAPTER.

16 (c) IMPOSES ON A VIDEO SERVICE PROVIDER ANY REQUIREMENT THAT IS
17 RELATED TO INFRASTRUCTURE, FACILITIES OR DEPLOYMENT OF EQUIPMENT THAT DOES
18 NOT CONFORM TO THIS CHAPTER, INCLUDING OFFICE LOCATION, INSTITUTIONAL
19 NETWORK, BUILD-OUT, LINE EXTENSION, INVESTMENT OR OTHER OPERATIONAL
20 REQUIREMENTS THAT ARE NOT DIRECTLY RELATED TO THE LOCAL GOVERNMENT'S
21 MANAGEMENT OF THE HIGHWAYS.

22 (d) REQUIRES A VIDEO SERVICE PROVIDER TO OBTAIN A LICENSE OR OTHER
23 AUTHORIZATION FROM THE LOCAL GOVERNMENT TO PROVIDE TELECOMMUNICATIONS
24 SERVICE, INFORMATION SERVICE, INTERACTIVE COMPUTER SERVICE OR OTHER
25 SERVICE IF THE VIDEO SERVICE PROVIDER USES ITS VIDEO SERVICE NETWORK
26 WITHIN THE BOUNDARIES OF THE LOCAL GOVERNMENT TO PROVIDE THE SERVICE.

27 (e) REQUIRES A VIDEO SERVICE PROVIDER TO PAY TO LOCATE IN DUCTS OR
28 CONDUITS OR ON POLES OWNED BY THE LOCAL GOVERNMENT IF THE LOCAL GOVERNMENT
29 REQUIRES INSTALLATION IN THE DUCTS OR CONDUITS OR ON THE POLES.

30 9-1403. Limited application

31 THIS CHAPTER DOES NOT:

32 1. PREVENT A TELECOMMUNICATIONS PROVIDER FROM EXERCISING ANY RIGHTS
33 OR AUTHORITY THAT THE TELECOMMUNICATIONS PROVIDER HAS AS A PUBLIC UTILITY
34 UNDER FEDERAL OR STATE LAW.

35 2. AFFECT ANY AUTHORITY OF A LOCAL GOVERNMENT, AN AGRICULTURAL
36 IMPROVEMENT DISTRICT, ANY SPECIAL TAXING DISTRICT OR ANY OTHER PERSON THAT
37 CONTROLS UTILITY POLES ON THE HIGHWAYS TO DENY, LIMIT, RESTRICT OR
38 DETERMINE THE RATES, TERMS AND CONDITIONS FOR THE USE OF OR ATTACHMENT BY
39 A VIDEO SERVICE PROVIDER TO UTILITY OR OTHER POLES OWNED BY THE LOCAL
40 GOVERNMENT OR OTHER PERSON. FOR THE PURPOSES OF THIS PARAGRAPH,
41 "AUTHORITY OF A LOCAL GOVERNMENT" INCLUDES POLICE POWERS.

42 3. VEST IN THE CORPORATION COMMISSION ANY AUTHORITY OR JURISDICTION
43 OVER VIDEO SERVICE, VIDEO SERVICE PROVIDERS OR VIDEO SERVICE NETWORKS OR
44 OVER THE RATES, TERMS AND CONDITIONS OF POLE ATTACHMENTS UNDER 47 UNITED
45 STATES CODE SECTION 224.

1 9. A REQUIREMENT THAT THE VIDEO SERVICE PROVIDER AGREES TO COMPLY
2 WITH ALL GENERALLY APPLICABLE, NONDISCRIMINATORY LOCAL LAWS, INCLUDING
3 HIGHWAY USE, MAPPING, INSURANCE, PERFORMANCE BONDS, SECURITY FUND,
4 INDEMNIFICATION OR SIMILAR REQUIREMENTS THAT APPLY TO THE USE AND
5 OCCUPATION OF ANY HIGHWAY AND THAT CONFORM TO THIS CHAPTER.

6 10. A REQUIREMENT THAT THE VIDEO SERVICE PROVIDER COMPLY WITH THE
7 PUBLIC, EDUCATION AND GOVERNMENT PROGRAMMING REQUIREMENTS OF THIS CHAPTER.

8 11. A REQUIREMENT THAT THE VIDEO SERVICE PROVIDER COMPLY WITH ALL
9 CUSTOMER SERVICE RULES OF THE FEDERAL COMMUNICATIONS COMMISSION UNDER 47
10 CODE OF FEDERAL REGULATIONS SECTION 76.309(c) APPLICABLE TO CABLE
11 OPERATORS.

12 12. A REQUIREMENT THAT THE VIDEO SERVICE PROVIDER COMPLY WITH THE
13 CONSUMER PRIVACY REQUIREMENTS OF 47 UNITED STATES CODE SECTION 551
14 APPLICABLE TO CABLE OPERATORS.

15 13. A GRANT OF AUTHORITY BY THE LOCAL GOVERNMENT TO PROVIDE VIDEO
16 SERVICE IN THE SERVICE AREA AS DESCRIBED UNDER PARAGRAPH 5 OF THIS
17 SUBSECTION.

18 14. A GRANT OF AUTHORITY BY THE LOCAL GOVERNMENT TO USE AND OCCUPY
19 THE HIGHWAYS IN THE DELIVERY OF THE VIDEO SERVICE, SUBJECT TO THE LAWS OF
20 THIS STATE AND THE POLICE POWERS OF THE LOCAL GOVERNMENT.

21 15. THE TERM OF THE UNIFORM VIDEO SERVICE LICENSE.

22 16. A REQUIREMENT THAT THE PARTIES TO THE AGREEMENT ARE SUBJECT TO
23 AND MUST COMPLY WITH THIS CHAPTER.

24 D. EXCEPT AS OTHERWISE PROVIDED IN THIS CHAPTER, FROM AND AFTER
25 DECEMBER 31, 2019 A PERSON MAY NOT ACT AS A VIDEO SERVICE PROVIDER OR
26 CONSTRUCT OR OPERATE A VIDEO SERVICE NETWORK WITHIN THE BOUNDARIES OF A
27 LOCAL GOVERNMENT WITHOUT FIRST HAVING BEEN ISSUED AND CONTINUING TO HOLD A
28 UNIFORM VIDEO SERVICE LICENSE WITH A SERVICE AREA ENCOMPASSING THE
29 BOUNDARIES.

30 E. A LOCAL LICENSE SHALL REMAIN ENFORCEABLE IN ACCORDANCE WITH ITS
31 TERMS UNTIL TERMINATED UNDER SECTION 9-1412, SUBSECTION B.

32 9-1412. Incumbent cable operator; election on local license;
33 procedure to obtain uniform video service license
34 and terminate local license

35 A. FROM AND AFTER DECEMBER 31, 2019, AN INCUMBENT CABLE OPERATOR
36 MAY ELECT TO DO EITHER OF THE FOLLOWING:

37 1. CONTINUE TO OPERATE WITHIN A SERVICE AREA AS DEFINED IN THE
38 LOCAL LICENSE PURSUANT TO SECTION 9-1413.

39 2. TERMINATE THE INCUMBENT CABLE OPERATOR'S LOCAL LICENSE FOR A
40 SERVICE AREA BY APPLYING FOR AND OBTAINING A UNIFORM VIDEO SERVICE LICENSE
41 PURSUANT TO THIS ARTICLE.

42 B. ON OR BEFORE JULY 1, 2020, TO ELECT TO TERMINATE A LOCAL LICENSE
43 UNDER SUBSECTION A OF THIS SECTION IN THE SAME MANNER AS ANY OTHER VIDEO
44 SERVICE PROVIDER, AN INCUMBENT CABLE OPERATOR SHALL APPLY FOR A UNIFORM
45 VIDEO SERVICE LICENSE THAT INCLUDES ONLY THE SERVICE AREA THAT IS DEFINED

1 IN THE LOCAL LICENSE. IF AN INCUMBENT CABLE OPERATOR OBTAINS A UNIFORM
2 VIDEO SERVICE LICENSE FOR THE SERVICE AREA, BOTH OF THE FOLLOWING APPLY:

3 1. THE APPLICANT'S LOCAL LICENSE IS TERMINATED AS TO THE SERVICE
4 AREA BY OPERATION OF LAW FROM AND AFTER THE DATE THE LOCAL GOVERNMENT
5 ISSUES THE UNIFORM VIDEO SERVICE LICENSE.

6 2. THE INCUMBENT CABLE OPERATOR SHALL OPERATE WITHIN THE SERVICE
7 AREA DEFINED IN THE LOCAL LICENSE UNLESS THE INCUMBENT CABLE OPERATOR
8 ELECTS UNDER SECTION 9-1414, SUBSECTION C TO APPLY FOR A UNIFORM VIDEO
9 SERVICE LICENSE FOR A SERVICE AREA THAT CONSISTS OF THE BOUNDARIES OF THE
10 LOCAL GOVERNMENT.

11 9-1413. Incumbent cable operator; procedure to continue
12 operating under local license

13 A. IF AN INCUMBENT CABLE OPERATOR DOES NOT TIMELY ELECT TO
14 TERMINATE A LOCAL LICENSE FOR A SERVICE AREA PURSUANT TO SECTION 9-1412,
15 SUBSECTION B, THE PERSON SHALL CONTINUE TO OPERATE THE CABLE SYSTEM AS A
16 HOLDOVER CABLE OPERATOR WITHIN THE SERVICE AREA DEFINED IN THE LOCAL
17 LICENSE AND SHALL COMPLY WITH THE LOCAL LICENSE FOR AS LONG AS IT REMAINS
18 IN EFFECT FOR THE SERVICE AREA. THE LOCAL LICENSE IS NOT EFFECTIVE FOR
19 THE SERVICE AREA FROM AND AFTER THE DATE THE LOCAL LICENSE EXPIRES BY ITS
20 TERMS. THE LOCAL GOVERNMENT MAY NOT UNILATERALLY RENEW OR EXTEND THE TERM
21 OF THE LOCAL LICENSE FOR THE SERVICE AREA. THE LOCAL GOVERNMENT AND THE
22 HOLDOVER CABLE OPERATOR SHALL COMPLY WITH ALL OF THE FOLLOWING, WHICH
23 SHALL CONTINUE TO APPLY TO THE LOCAL LICENSE:

- 24 1. CHAPTER 5, ARTICLE 1.1 OF THIS TITLE.
- 25 2. SECTION 9-584.
- 26 3. CHAPTER 5, ARTICLE 8 OF THIS TITLE.
- 27 4. TITLE 11, CHAPTER 13, ARTICLE 1.

28 B. TO OPERATE WITHIN A SERVICE AREA FROM AND AFTER THE DATE THE
29 LOCAL LICENSE EXPIRES, THE HOLDOVER CABLE OPERATOR MUST APPLY FOR AND
30 OBTAIN A UNIFORM VIDEO SERVICE LICENSE IN THE SAME MANNER AS ANY OTHER
31 VIDEO SERVICE PROVIDER.

32 C. IF A HOLDOVER CABLE OPERATOR IS ISSUED A UNIFORM VIDEO SERVICE
33 LICENSE WITH A SERVICE AREA THAT INCLUDES THE SERVICE AREA DEFINED UNDER
34 THE LOCAL LICENSE WHILE OPERATING PURSUANT TO THE LOCAL LICENSE UNDER
35 SUBSECTION A OF THIS SECTION, THE UNIFORM VIDEO SERVICE LICENSE DOES NOT
36 BECOME EFFECTIVE UNTIL THE LOCAL LICENSE EXPIRES.

37 D. A HOLDOVER CABLE OPERATOR THAT ELECTS TO APPLY FOR A UNIFORM
38 VIDEO SERVICE LICENSE SHALL DO SO AT LEAST ONE MONTH BEFORE THE LOCAL
39 LICENSE EXPIRES.

40 9-1414. Uniform video service license; application; fees

41 A. TO OBTAIN A UNIFORM VIDEO SERVICE LICENSE, A PERSON SHALL FILE
42 WITH THE CLERK OF THE LOCAL GOVERNMENT AN APPLICATION AND AFFIDAVIT THAT
43 ARE SIGNED BY ONE OF THE PRINCIPAL EXECUTIVE OFFICERS OR GENERAL PARTNERS
44 OF THE APPLICANT AND THAT COMPLY WITH THIS SECTION.

1 B. THE APPLICATION AND AFFIDAVIT SHALL BE IN THE FORM REQUIRED BY
2 THE LOCAL GOVERNMENT AND SHALL BE REQUIRED TO CONTAIN ALL OF AND NOT MORE
3 THAN THE FOLLOWING:

4 1. EACH SERVICE AREA IN WHICH THE APPLICANT INTENDS TO PROVIDE
5 VIDEO SERVICE IN THE FORMAT AS DESCRIBED IN SECTION 9-1411, SUBSECTION C.
6 EXCEPT AS PROVIDED IN SECTION 9-1412, SUBSECTION B, PARAGRAPH 2, UNDER A
7 UNIFORM VIDEO SERVICE LICENSE THE BOUNDARIES OF THE LOCAL GOVERNMENT IS A
8 SINGLE SERVICE AREA AND THE SERVICE AREA CONSISTS OF ALL OF THE TERRITORY
9 WITHIN THE BOUNDARIES OF THAT LOCAL GOVERNMENT.

10 2. THE INFORMATION PRESCRIBED BY SECTION 9-1411, SUBSECTION C,
11 PARAGRAPHS 1 THROUGH 4. THE HOLDER SHALL NOTIFY THE LOCAL GOVERNMENT IN
12 WRITING OF CHANGES TO THIS INFORMATION WITHIN THIRTY DAYS AFTER THE CHANGE
13 OCCURS.

14 3. THE TERM OF THE UNIFORM VIDEO SERVICE LICENSE, WHICH MAY NOT
15 EXCEED TEN YEARS.

16 4. AN AGREEMENT TO PAY ALL LAWFUL FEES AND CHARGES IMPOSED BY THE
17 LOCAL GOVERNMENT.

18 C. AN INCUMBENT CABLE OPERATOR DESCRIBED IN SECTION 9-1412,
19 SUBSECTION B, PARAGRAPH 2 MAY ELECT TO APPLY FOR A UNIFORM VIDEO SERVICE
20 LICENSE FOR A SERVICE AREA THAT CONSISTS OF THE BOUNDARIES OF A LOCAL
21 GOVERNMENT.

22 D. IF THE LOCAL GOVERNMENT DETERMINES THAT THE APPLICATION AND
23 AFFIDAVIT ARE INCOMPLETE OR OTHERWISE DEFICIENT FOR FAILURE TO COMPLY WITH
24 THIS SECTION, THE LOCAL GOVERNMENT SHALL PROVIDE WRITTEN NOTICE TO THE
25 APPLICANT NOT LATER THAN FIFTEEN DAYS AFTER THE DATE OF FILING OF THE
26 APPLICATION AND AFFIDAVIT. THE WRITTEN NOTICE SHALL DO BOTH OF THE
27 FOLLOWING:

28 1. EXPLAIN THE INCOMPLETENESS OR DEFICIENCY IN DETAIL.

29 2. SPECIFY THE INFORMATION OR OTHER ITEMS THAT ARE NECESSARY UNDER
30 THIS SECTION FOR PROPER COMPLETION OF THE APPLICATION AND AFFIDAVIT.

31 E. THE LOCAL GOVERNMENT MAY NOT DO ANY OF THE FOLLOWING:

32 1. CHARGE A FEE FOR FILING OR PROCESSING AN APPLICATION, AFFIDAVIT,
33 NOTICE OR OTHER DOCUMENT UNDER THIS CHAPTER.

34 2. VOTE ON OR TAKE OTHER OFFICIAL ACTION REGARDING THE APPLICATION,
35 AFFIDAVIT, NOTICE OR OTHER DOCUMENT.

36 3. REQUIRE THE APPLICANT TO OBTAIN THE APPROVAL OF THE LOCAL
37 GOVERNMENT REGARDING THE APPLICATION, AFFIDAVIT, NOTICE OR OTHER DOCUMENT.

38 4. REQUIRE THE APPLICANT TO ENTER INTO AN AGREEMENT AS DESCRIBED IN
39 SECTION 9-1442, SUBSECTION I.

40 9-1415. Authority granted by uniform video service license;
41 conditions and limitations prohibited; providing
42 video service

43 A. NOT LATER THAN THIRTY DAYS AFTER THE DATE AN APPLICANT FILES A
44 COMPLETED APPLICATION AND AFFIDAVIT PURSUANT TO SECTION 9-1414, THE LOCAL
45 GOVERNMENT SHALL ISSUE A UNIFORM VIDEO SERVICE LICENSE TO THE APPLICANT IN

1 THE FORM PRESCRIBED BY SECTION 9-1411. IF THE LOCAL GOVERNMENT DOES NOT
2 NOTIFY THE APPLICANT ABOUT THE COMPLETENESS OF THE UNIFORM VIDEO SERVICE
3 LICENSE AGREEMENT WITHIN THE TIME PERIOD PRESCRIBED BY SECTION 9-1414,
4 SUBSECTION D OR ISSUE THE AGREEMENT WITHIN THE TIME PERIOD REQUIRED UNDER
5 THIS SUBSECTION, THE AGREEMENT SHALL BE CONSIDERED COMPLETE AND ISSUED TO
6 THE APPLICANT IN THE FORM SUBMITTED.

7 B. THE UNIFORM VIDEO SERVICE LICENSE ISSUED TO AN APPLICANT,
8 INCLUDING AN INCUMBENT CABLE OPERATOR, BY A LOCAL GOVERNMENT IS A
9 NONEXCLUSIVE LICENSE GRANTING TO THE HOLDER OF THE UNIFORM VIDEO SERVICE
10 LICENSE THE AUTHORITY FOR THE TERM REQUESTED IN THE APPLICATION TO DO ALL
11 OF THE FOLLOWING:

12 1. PROVIDE VIDEO SERVICE IN ALL SERVICE AREAS DESIGNATED IN THE
13 APPLICATION AND AFFIDAVIT FILED WITH THE LOCAL GOVERNMENT.

14 2. CONSTRUCT AND OPERATE A VIDEO SERVICE NETWORK IN THE HIGHWAYS IN
15 EACH SERVICE AREA IN COMPLIANCE WITH THIS CHAPTER AND ALL LOCAL LAWS THAT
16 ARE NOT IN CONFLICT OR OTHERWISE DO NOT CONFORM TO THIS CHAPTER OR THE
17 PURPOSES AND OBJECTIVES OF THIS CHAPTER.

18 3. OPERATE AND MAINTAIN FACILITIES INSTALLED IN THE HIGHWAYS IN THE
19 SERVICE AREA UNDER A LOCAL LICENSE PURSUANT TO ALL OF THE FOLLOWING:

20 (a) SECTION 9-506, SUBSECTIONS I AND J.

21 (b) SECTION 9-584.

22 (c) CHAPTER 5, ARTICLE 8 OF THIS TITLE AND TITLE 11, CHAPTER 13,
23 ARTICLE 1.

24 C. A LOCAL GOVERNMENT MAY NOT CONDITION OR LIMIT A UNIFORM VIDEO
25 SERVICE LICENSE BY IMPOSING ANY OBLIGATION OR REQUIREMENT THAT IS NOT
26 AUTHORIZED BY THIS CHAPTER, INCLUDING ANY OF THE FOLLOWING:

27 1. ANY OFFICE LOCATION, INSTITUTIONAL NETWORK OR OTHER BUILD-OUT,
28 LINE EXTENSION, INVESTMENT OR OTHER REQUIREMENTS RELATING TO THE OVERALL
29 SCOPE, EXTENT AND TIMING OF INFRASTRUCTURE, FACILITIES OR DEPLOYMENT OF
30 EQUIPMENT.

31 2. ANY REQUIREMENTS TO PAY TO ANY PERSON ANY APPLICATION, DOCUMENT,
32 LICENSE, SERVICE OR OTHER FEE, TAX, CHARGE OR ASSESSMENT THAT IS NOT
33 AUTHORIZED BY THIS CHAPTER.

34 D. A HOLDER OF A UNIFORM VIDEO SERVICE LICENSE SHALL PROVIDE VIDEO
35 SERVICE IN ACCORDANCE WITH THE CERTIFICATIONS MADE BY THE HOLDER IN EACH
36 APPLICATION AND AFFIDAVIT THAT THE HOLDER FILES WITH A LOCAL GOVERNMENT
37 PURSUANT TO THIS ARTICLE.

38 9-1416. Amendment of uniform video service license to add
39 service area

40 A. TO ADD ONE OR MORE NEW SERVICE AREAS TO A UNIFORM VIDEO SERVICE
41 LICENSE, THE HOLDER SHALL FILE WITH THE CLERK OF THE LOCAL GOVERNMENT AN
42 APPLICATION FOR AN AMENDMENT TO THE UNIFORM VIDEO SERVICE LICENSE TO ADD
43 EACH NEW SERVICE AREA.

1 B. THE APPLICATION IS SUBJECT TO THE SAME PROCEDURES, REQUIREMENTS,
2 LIMITATIONS AND TIME PERIODS AS AN APPLICATION FOR ISSUANCE OF A UNIFORM
3 VIDEO SERVICE LICENSE PURSUANT TO SECTIONS 9-1414 AND 9-1415.

4 9-1417. Termination of service

5 A. TO TERMINATE THE AUTHORITY TO PROVIDE VIDEO SERVICE TO AN
6 EXISTING SERVICE AREA AUTHORIZED UNDER THE UNIFORM VIDEO SERVICE LICENSE,
7 THE HOLDER OF THE UNIFORM VIDEO SERVICE LICENSE SHALL FILE WITH THE CLERK
8 OF THE LOCAL GOVERNMENT WRITTEN NOTICE OF THE TERMINATION.

9 B. THE HOLDER MAY TERMINATE SERVICE ON AND AFTER THE DATE THAT THE
10 HOLDER FILES THE WRITTEN NOTICE WITH THE CLERK OF THE LOCAL GOVERNMENT.

11 C. THE HOLDER SHALL:

12 1. COMPLY WITH APPLICABLE FEDERAL LAWS, INCLUDING RULES AND
13 REGULATIONS OF THE FEDERAL COMMUNICATIONS COMMISSION.

14 2. GIVE ALL AFFECTED SUBSCRIBERS AND LOCAL GOVERNMENTS NOTICE AT
15 LEAST NINETY DAYS BEFORE TERMINATION OF SERVICE IN ALL OF A SERVICE AREA
16 THAT CONSISTS OF THE BOUNDARIES OF THE LOCAL GOVERNMENT.

17 9-1418. Boundary change

18 EACH LOCAL GOVERNMENT WHOSE BOUNDARIES CHANGE SHALL NOTIFY IN A
19 TIMELY MANNER EACH VIDEO SERVICE PROVIDER THAT OPERATES IN THE BOUNDARIES.

20 9-1419. Transfer of uniform video service license

21 A. EXCEPT AS OTHERWISE PROVIDED IN THIS SECTION OR OTHERWISE
22 REQUIRED BY FEDERAL LAW, INCLUDING RULES AND REGULATIONS OF THE FEDERAL
23 COMMUNICATIONS COMMISSION, A UNIFORM VIDEO SERVICE LICENSE IS FULLY
24 TRANSFERABLE TO ANY PERSON WHETHER THE TRANSFER ARISES THROUGH MERGER,
25 SALE, ASSIGNMENT, RESTRUCTURING, CHANGE OF CONTROL OR OTHER TYPE OF
26 TRANSACTION. A TRANSFER DOES NOT INCLUDE AN ASSIGNMENT OF A UNIFORM VIDEO
27 SERVICE LICENSE FOR THE PURPOSE OF SECURING INDEBTEDNESS. A TRANSFER MAY
28 INCLUDE LESS THAN ALL SERVICE AREAS ASSOCIATED WITH A UNIFORM VIDEO
29 SERVICE LICENSE.

30 B. THE HOLDER SHALL FILE WITH THE CLERK OF THE LOCAL GOVERNMENT
31 WRITTEN NOTICE OF THE TRANSFER OF THE UNIFORM VIDEO SERVICE LICENSE. ON
32 THE FILING OF NOTICE UNDER THIS SUBSECTION THE TRANSFEREE BECOMES THE
33 HOLDER.

34 9-1420. Extension

35 A. TO EXTEND THE TERM OF A UNIFORM VIDEO SERVICE LICENSE, THE
36 HOLDER OF THE UNIFORM VIDEO SERVICE LICENSE SHALL FILE WITH THE CLERK OF
37 THE LOCAL GOVERNMENT AT LEAST ONE MONTH BEFORE THE END OF THE TERM OF THE
38 UNIFORM VIDEO SERVICE LICENSE A NOTICE TO EXTEND THE TERM FOR A SPECIFIED
39 PERIOD NOT TO EXCEED TEN YEARS.

40 B. EFFECTIVE ON THE DATE THE HOLDER FILES THE WRITTEN NOTICE WITH
41 THE CLERK OF THE LOCAL GOVERNMENT, THE TERM IS EXTENDED FOR THE SPECIFIED
42 PERIOD FROM AND AFTER THE DATE OF THE END OF THE THEN-CURRENT TERM.

43 C. TRANSFERRING, AMENDING OR MODIFYING A UNIFORM VIDEO SERVICE
44 LICENSE UNDER OTHER SECTIONS OF THIS ARTICLE DOES NOT EXTEND THE TERM OF
45 THE UNIFORM VIDEO SERVICE LICENSE.

1 9-1421. Subscriber complaints

2 A. A SUBSCRIBER MAY SUBMIT COMPLAINTS ABOUT VIDEO SERVICE TO ANY OF
3 THE FOLLOWING:

- 4 1. THE LOCAL GOVERNMENT WHERE THE SUBSCRIBER RESIDES.
- 5 2. THE ATTORNEY GENERAL.
- 6 3. THE FEDERAL COMMUNICATIONS COMMISSION.
- 7 4. OTHER AUTHORITIES AS PROVIDED BY LAW.

8 B. A LOCAL GOVERNMENT MAY CHOOSE TO MONITOR AND ASSIST SUBSCRIBERS
9 WITH THE SUBSCRIBER SERVICE STANDARDS PURSUANT TO 47 CODE OF FEDERAL
10 REGULATIONS SECTION 76.309(c) OR TO BE IDENTIFIED ON BILLS TO SUBSCRIBERS
11 AS THE LOCAL FRANCHISE AUTHORITY FOR A SERVICE AREA CONSISTENT WITH RULES
12 OF THE FEDERAL COMMUNICATIONS COMMISSION.

13 ARTICLE 3. DUTIES OF VIDEO SERVICE PROVIDERS

14 9-1431. Video service; revocation for nonuse

15 A. NOT LATER THAN TWENTY-FOUR MONTHS AFTER THE DATE THAT A LOCAL
16 GOVERNMENT ISSUES A UNIFORM VIDEO SERVICE LICENSE PURSUANT TO SECTIONS
17 9-1414 AND 9-1415 OR AN AMENDED UNIFORM VIDEO SERVICE LICENSE PURSUANT TO
18 SECTION 9-1416, THE HOLDER OF THE UNIFORM VIDEO SERVICE LICENSE SHALL
19 OFFER AND PROVIDE VIDEO SERVICE TO AT LEAST ONE SUBSCRIBER WITHIN EACH
20 SERVICE AREA AUTHORIZED BY THE UNIFORM VIDEO SERVICE LICENSE OR AMENDED
21 UNIFORM VIDEO SERVICE LICENSE UNLESS THE HOLDER CANNOT MEET THE
22 REQUIREMENT FOR REASONS BEYOND THE HOLDER'S CONTROL.

23 B. IF A HOLDER FAILS TO COMPLY WITH SUBSECTION A OF THIS SECTION, A
24 LOCAL GOVERNMENT MAY REVOKE THE HOLDER'S UNIFORM VIDEO SERVICE LICENSE FOR
25 AFFECTED SERVICE AREAS.

26 9-1432. Reports; confidentiality; definition

27 A. A VIDEO SERVICE PROVIDER THAT IS NOT AN INCUMBENT CABLE OPERATOR
28 AND THAT HOLDS A UNIFORM VIDEO SERVICE LICENSE WITH A SERVICE AREA WITHIN
29 THE BOUNDARIES OF A LOCAL GOVERNMENT SHALL PREPARE AND SUBMIT TO THE LOCAL
30 GOVERNMENT A SEMIANNUAL REPORT THAT IDENTIFIES THE LOCATIONS WITHIN THE
31 BOUNDARIES THAT ARE ABLE TO RECEIVE VIDEO SERVICE FROM THE VIDEO SERVICE
32 PROVIDER. THIS REPORTING REQUIREMENT APPLIES UNTIL THE VIDEO SERVICE
33 PROVIDER HAS CONSTRUCTED ALL OF THE FACILITIES THE VIDEO SERVICE PROVIDER
34 INTENDS TO CONSTRUCT WITHIN THE BOUNDARIES OF THE LOCAL GOVERNMENT.

35 B. THE VIDEO SERVICE PROVIDER SHALL FILE THE REPORT WITH THE LOCAL
36 GOVERNMENT NOT LATER THAN TWENTY DAYS AFTER THE LAST DAY OF THE SECOND AND
37 FOURTH CALENDAR QUARTERS OF EACH YEAR.

38 C. INFORMATION CONTAINED IN A REPORT THAT IS SUBMITTED TO A LOCAL
39 GOVERNMENT PURSUANT TO THIS SECTION:

- 40 1. IS CONFIDENTIAL PROPRIETARY INFORMATION OF THE VIDEO SERVICE
41 PROVIDER.
- 42 2. IS NOT A PUBLIC RECORD.
- 43 3. MUST BE MANAGED SO THAT ANY CRITICAL INFRASTRUCTURE INFORMATION
44 CONTAINED IN THE REPORT IS PROTECTED AS PROVIDED BY LAW.

1 4. MAY NOT BE DISCLOSED TO ANY PERSON WHO IS NOT AN OFFICER OR
2 EMPLOYEE OF THE LOCAL GOVERNMENT UNLESS THE VIDEO SERVICE PROVIDER HAS
3 CONSENTED IN WRITING TO THE DISCLOSURE.

4 D. FOR THE PURPOSES OF THIS SECTION, "CRITICAL INFRASTRUCTURE
5 INFORMATION" HAS THE SAME MEANING PRESCRIBED IN SECTION 41-1801.

6 9-1433. Nondiscriminatory manner; compliance with standards
7 and federal law

8 A. A VIDEO SERVICE PROVIDER SHALL ACTIVATE AND OFFER VIDEO SERVICE
9 IN A NONDISCRIMINATORY MANNER WITHIN EACH SERVICE AREA AND MAY NOT DENY
10 ACCESS TO VIDEO SERVICE TO ANY GROUP OF POTENTIAL RESIDENTIAL SUBSCRIBERS
11 WITHIN A PARTICULAR PART OF A SERVICE AREA BECAUSE OF THE INCOME PROFILE
12 OF THE PERSONS WHO RESIDE IN THAT PART OF THE SERVICE AREA.

13 B. IN PROVIDING VIDEO SERVICE, A VIDEO SERVICE PROVIDER SHALL
14 COMPLY WITH ALL OF THE FOLLOWING:

15 1. 47 UNITED STATES CODE SECTION 551.

16 2. ALL ENGINEERING AND SAFETY CODES APPLICABLE TO THE VIDEO SERVICE
17 PROVIDER'S CONSTRUCTION PRACTICES AND INSTALLATION OF EQUIPMENT.

18 3. ANY TECHNICAL STANDARDS GOVERNING THE DESIGN, CONSTRUCTION AND
19 OPERATION OF A VIDEO SERVICE NETWORK REQUIRED BY FEDERAL LAW.

20 4. 47 CODE OF FEDERAL REGULATIONS PART 11, AS ADOPTED AND AS MAY BE
21 AMENDED BY THE FEDERAL COMMUNICATIONS COMMISSION, TO THE EXTENT THOSE
22 PROVISIONS REQUIRE A VIDEO SERVICE PROVIDER TO PARTICIPATE IN THE
23 EMERGENCY ALERT SYSTEM.

24 5. 47 CODE OF FEDERAL REGULATIONS SECTIONS 76.309, 76.1601,
25 76.1602, 76.1603, 76.1604, 76.1618, 76.1619, 76.1620, 76.1621 AND 76.1622,
26 AS ADOPTED AND AS MAY BE AMENDED BY THE FEDERAL COMMUNICATIONS COMMISSION,
27 ON STANDARDS GOVERNING THE QUALITY OF VIDEO SERVICE AND SUBSCRIBER
28 SERVICE. A VIDEO SERVICE PROVIDER MAY NOT BE REQUIRED TO COMPLY WITH ANY
29 SUBSCRIBER SERVICE STANDARDS THAT ARE MORE BURDENSOME THAN THOSE SET FORTH
30 IN THIS PARAGRAPH.

31 ARTICLE 4. LOCAL GOVERNMENTS

32 9-1441. Management of highways; local governments; permits or
33 licenses

34 A. IN MANAGING A HIGHWAY UNDER LOCAL LAWS AS PRESCRIBED IN SECTION
35 9-1411, SUBSECTION C, PARAGRAPH 9, A LOCAL GOVERNMENT MAY MANAGE THE USE
36 OF THE HIGHWAY, INCLUDING ALL OF THE FOLLOWING:

37 1. REQUIRING A VIDEO SERVICE PROVIDER THAT IS CONSTRUCTING,
38 INSTALLING, WORKING WITHIN, MAINTAINING OR REPAIRING FACILITIES IN, ON,
39 UNDER OR OVER ANY HIGHWAY TO OBTAIN A CONSTRUCTION, ENCROACHMENT OR
40 OCCUPANCY PERMIT FOR THE WORK.

41 2. INSPECTING THE CONSTRUCTION, INSTALLATION, MAINTENANCE OR REPAIR
42 WORK PERFORMED ON SUCH FACILITIES.

43 3. LIMITING THE INSTALLATION OF NEW AERIAL FACILITIES.

1 B. IF A VIDEO SERVICE PROVIDER REQUESTS A PERMIT OR INSPECTION, THE
2 LOCAL GOVERNMENT SHALL GRANT OR DENY THE REQUEST WITHIN THE TIME FRAME
3 THAT THE LOCAL GOVERNMENT HAS IN PLACE UNDER SECTION 9-835 OR 11-1605.

4 C. IF EMERGENCY RESPONSE WORK OR REPAIR BECOMES NECESSARY IN, ON,
5 UNDER OR OVER ANY HIGHWAY, A VIDEO SERVICE PROVIDER MAY BEGIN THAT WORK OR
6 REPAIR WITHOUT PRIOR APPROVAL FROM A LOCAL GOVERNMENT IF THE VIDEO SERVICE
7 PROVIDER NOTIFIES THE LOCAL GOVERNMENT AS PROMPTLY AS REASONABLY POSSIBLE
8 AFTER LEARNING THAT THE WORK OR REPAIR IS NECESSARY.

9 9-1442. Fees and charges; emergency alert; damage;
10 undergrounding; wireless facilities; definition

11 A. EXCEPT THE LICENSE FEE ON GROSS REVENUE AUTHORIZED BY SECTION
12 9-1443 AND TRANSACTION PRIVILEGE TAXES AS PROVIDED IN SUBSECTION B OF THIS
13 SECTION, A LOCAL GOVERNMENT MAY NOT LEVY A TAX, RENT, FEE OR CHARGE,
14 HOWEVER DENOMINATED, ON A VIDEO SERVICE PROVIDER FOR THE USE OF THE
15 HIGHWAYS TO PROVIDE VIDEO SERVICE OR LEVY A TAX, FEE OR CHARGE ON THE
16 PRIVILEGE OF ENGAGING IN THE BUSINESS OF PROVIDING VIDEO SERVICE IN THE
17 SERVICE AREA. TAXES, RENTS, FEES AND CHARGES INCLUDE ALL OF THE
18 FOLLOWING:

19 1. ACCESS CHANNEL SUPPORT EXCEPT FOR IN-KIND SERVICES, GOODS OR
20 PAYMENTS AS PROVIDED IN SUBSECTION C OF THIS SECTION.

21 2. RENTAL, APPLICATION, CONSTRUCTION, PERMIT, INSPECTION,
22 INCONVENIENCE AND OTHER FEES AND CHARGES RELATED TO A VIDEO SERVICE
23 PROVIDER'S USE OF THE HIGHWAYS, INCLUDING THE USE AUTHORIZED BY SUBSECTION
24 D OF THIS SECTION EXCEPT THAT A LOCAL GOVERNMENT MAY IMPOSE ON A VIDEO
25 SERVICE PROVIDER SOME OR ALL OF THE FEES AND CHARGES DESCRIBED IN THIS
26 PARAGRAPH. A VIDEO SERVICE PROVIDER SHALL OFFSET THE FEES AND CHARGES
27 IMPOSED PURSUANT TO THIS PARAGRAPH AGAINST THE NEXT LICENSE FEE PAYMENT
28 MADE PURSUANT TO SECTION 9-1443.

29 B. ANY TRANSACTION PRIVILEGE TAXES OTHERWISE AUTHORIZED BY LOCAL
30 LAW TO BE LEVIED ON THE BUSINESS OF PROVIDING VIDEO SERVICE OR IN RELATION
31 TO USE OF THE HIGHWAYS TO PROVIDE VIDEO SERVICE MAY BE LEVIED ON A VIDEO
32 SERVICE PROVIDER IF THE TAXES ARE LEVIED ONLY ON GROSS REVENUE AND THE
33 RATE OF THE TAXES IS SUBJECT TO THIS SUBSECTION. THIS SUBSECTION DOES NOT
34 AUTHORIZE THE IMPOSITION OF TRANSACTION PRIVILEGE TAXES ON INTERSTATE
35 TELECOMMUNICATIONS SERVICE. THE LICENSE FEE AND ANY TRANSACTION PRIVILEGE
36 TAXES LEVIED ON GROSS REVENUE CONSTITUTE A FRANCHISE FEE WITHIN THE
37 MEANING OF THE TERM IN 47 UNITED STATES CODE SECTION 542(g). THE TOTAL OF
38 THE RATES OF THE LICENSE FEE AND OF ANY TRANSACTION PRIVILEGE TAXES ON
39 GROSS REVENUE LEVIED OR ASSESSED BY A LOCAL GOVERNMENT FOR THE PRIVILEGE
40 OF PROVIDING VIDEO SERVICE AND RELATED USE OF THE HIGHWAYS TO PROVIDE
41 VIDEO SERVICE MAY NOT EXCEED A RATE OF FIVE PERCENT.

42 C. SUBSECTION A OF THIS SECTION DOES NOT PROHIBIT A LOCAL
43 GOVERNMENT FROM LEVYING FEES AND CHARGES ON A VIDEO SERVICE PROVIDER OR
44 ITS AFFILIATES PURSUANT TO SECTION 9-584 OR PURSUANT TO CHAPTER 5, ARTICLE

1 8 OF THIS TITLE OR TITLE 11, CHAPTER 13, ARTICLE 1 WITHOUT AN OFFSET
2 AGAINST LICENSE FEES.

3 D. A LOCAL GOVERNMENT MAY NOT REQUIRE A VIDEO SERVICE PROVIDER TO
4 PROVIDE IN-KIND GOODS OR SERVICES, MAKE IN-KIND PAYMENTS, ASSESSMENTS OR
5 OBLIGATIONS OR PAY A FEE IN ADDITION TO THE MONETARY LICENSE FEE LEVIED OR
6 ASSESSED AS PROVIDED IN SECTION 9-1443, EXCEPT FOR ANY OF THE FOLLOWING:

7 1. A LOCAL LAW MAY IMPOSE AND ENFORCE OBLIGATIONS EQUALLY AND
8 UNIFORMLY ON ALL VIDEO SERVICE PROVIDERS THAT ARE OPERATING WITHIN THE
9 BOUNDARIES OF A LOCAL GOVERNMENT AND ON ALL HOLDOVER CABLE OPERATORS THAT
10 HOLD A LOCAL LICENSE THAT REMAINS IN EFFECT UNDER SECTION 9-1414,
11 SUBSECTION A. UNDER THE LOCAL LAW, A LOCAL GOVERNMENT:

12 (a) MAY REQUIRE ALL VIDEO SERVICE PROVIDERS TO PROVIDE CHANNEL
13 CAPACITY FOR THE VIDEO SERVICE PROVIDER TO TRANSMIT PROGRAMMING OVER WHICH
14 THE VIDEO SERVICE PROVIDER EXERCISES NO EDITORIAL CONTROL EXCEPT AS
15 AUTHORIZED BY 47 UNITED STATES CODE SECTION 531(e). THE CHANNEL CAPACITY
16 SHALL BE LIMITED TO ONE OF THE FOLLOWING:

17 (i) NOT MORE THAN TWO CHANNELS OF PUBLIC, EDUCATIONAL OR
18 GOVERNMENTAL ACCESS PROGRAMMING IN THE BASIC SERVICE TIER OF THE VIDEO
19 SERVICE NETWORK AND NOT MORE THAN TWO CHANNELS OF NONCOMMERCIAL
20 GOVERNMENTAL PROGRAMMING, AT LEAST ONE OF WHICH MAY BE PROGRAMMED BY THE
21 FEDERAL GOVERNMENT, IN THE DIGITAL PROGRAMMING TIER OF THE VIDEO SERVICE
22 NETWORK.

23 (ii) NOT MORE THAN TWO LINES OF ACCESS PROGRAMMING WITH EACH LINE
24 OF PROGRAMMING CARRIED ON UP TO TWO STANDARD DEFINITION CHANNELS AND TWO
25 SWITCHED DIGITAL HIGH-DEFINITION CHANNELS.

26 (b) SHALL SPECIFY THE PROGRAMMING AND THE VIDEO SERVICE PROVIDER
27 MAY REQUIRE THAT THE CHANNELS REGULARLY DISPLAY AN UNOBTRUSIVE LOGO OR
28 OTHER SUITABLE IDENTIFIER OF THE VIDEO SERVICE PROVIDER, IF THE LOCAL
29 GOVERNMENT REQUIRES CHANNEL CAPACITY PURSUANT TO SUBDIVISION (a) OF THIS
30 PARAGRAPH.

31 (c) MAY REQUIRE ALL VIDEO SERVICE PROVIDERS TO INCUR COSTS AND
32 EXPENSES TO PROVIDE, MAINTAIN AND OPERATE FACILITIES AND EQUIPMENT OF THE
33 VIDEO SERVICE NETWORK, INCLUDING FACILITIES AND EQUIPMENT FOR SIGNAL
34 CARRIAGE, PROCESSING, REFORMATTING AND INTERCONNECTION FOR ALL OF THE
35 FOLLOWING:

36 (i) TO CONNECT THE VIDEO SERVICE NETWORK OR CABLE SYSTEM, AS IT MAY
37 BE RELOCATED FROM TIME TO TIME, TO TRANSMIT PROGRAMMING TO AND FROM
38 EXISTING LOCATIONS OF PUBLIC, EDUCATIONAL OR GOVERNMENTAL ACCESS
39 FACILITIES AND TO ALLOW MONITORING OF ACCESS PROGRAMMING AT THE
40 FACILITIES.

41 (ii) TO TRANSMIT PUBLIC, EDUCATIONAL AND GOVERNMENTAL ACCESS
42 CHANNELS TO SUBSCRIBERS WITH THE SAME PREVAILING QUALITY, FUNCTIONALITY
43 AND IDENTIFICATION AS OTHER CHANNELS.

44 (d) MAY REQUIRE ALL VIDEO SERVICE PROVIDERS AND INCUMBENT CABLE
45 OPERATORS TO PROVIDE AT NO INITIAL OR RECURRING CHARGE THE BASIC SERVICE

1 TIER OF VIDEO SERVICE TO ONE OUTLET AND ONE RECEIVING DEVICE AT EACH
2 BUILDING OCCUPIED BY THE LOCAL GOVERNMENT IF THE BUILDING IS NOT MORE THAN
3 TWO HUNDRED FEET FROM THE NEAREST TECHNICALLY AND COMMERCIALY FEASIBLE
4 POINT OF CONNECTION ON THE VIDEO SERVICE NETWORK.

5 2. A LOCAL GOVERNMENT MAY RETAIN NONRECEIVING EQUIPMENT THAT IT
6 OWNS WITHOUT CHARGE FOR THE EQUIPMENT'S USE AND AT THE LOCAL GOVERNMENT'S
7 EXPENSE, INCLUDING EQUIPMENT PREVIOUSLY PROVIDED BY AN INCUMBENT CABLE
8 OPERATOR.

9 E. A LOCAL LAW MAY NOT IMPOSE ANY OBLIGATION ON A VIDEO SERVICE
10 PROVIDER UNDER SUBSECTION D OF THIS SECTION THAT IS MORE BURDENSOME THAN
11 THE LEAST BURDENSOME REQUIREMENT UNDER ANY LOCAL LICENSE WITH A SERVICE
12 AREA WITHIN THE BOUNDARIES OF THE LOCAL GOVERNMENT THAT WAS IN EFFECT ON
13 FEBRUARY 1, 2019.

14 F. NONE OF THE ANNUAL FAIR MARKET VALUE OF ANY CHANNEL CAPACITY
15 PROVIDED PURSUANT TO SUBSECTION D, PARAGRAPH 1, SUBDIVISION (a), THE
16 ANNUAL COSTS AND EXPENSES INCURRED PURSUANT TO SUBSECTION D, PARAGRAPH 1,
17 SUBDIVISION (c) AND THE ANNUAL FAIR MARKET VALUE OF BASIC SERVICE AND LINE
18 EXTENSION PROVIDED PURSUANT TO SUBSECTION D, PARAGRAPH 1, SUBDIVISION (d)
19 MAY BE OFFSET AGAINST THE LICENSE FEE LEVIED OR ASSESSED UNDER THIS
20 SECTION.

21 G. NOTWITHSTANDING SUBSECTION A OF THIS SECTION, BY A
22 NONDISCRIMINATORY LOCAL LAW THAT IMPOSES AND ENFORCES THE OBLIGATIONS
23 EQUALLY AND UNIFORMLY ON ALL VIDEO SERVICE PROVIDERS OPERATING WITHIN THE
24 BOUNDARIES OF A LOCAL GOVERNMENT, A LOCAL GOVERNMENT MAY REQUIRE THAT A
25 VIDEO SERVICE PROVIDER BEAR ALL OF THE REASONABLE COSTS THAT ARE
26 ASSOCIATED WITH REPAIR AND RESTORATION OF DAMAGE CAUSED TO PRIVATE
27 PROPERTY OR HIGHWAYS BY THE REPAIR, REPLACEMENT, INSTALLATION,
28 CONSTRUCTION, MAINTENANCE OR OPERATION OF THE VIDEO SERVICE PROVIDER'S
29 FACILITIES IN THE HIGHWAYS AND THAT ARE IMPOSED ON A COMPETITIVELY NEUTRAL
30 AND NONDISCRIMINATORY BASIS IN RELATION TO COSTS BORNE BY
31 TELECOMMUNICATIONS CORPORATIONS UNDER SECTION 9-582, SUBSECTION C.

32 H. ON APPLICATION A LOCAL GOVERNMENT SHALL ISSUE TO A VIDEO SERVICE
33 PROVIDER OR ITS AFFILIATE A PERMIT TO ATTACH ALLOWED WI-FI RADIO EQUIPMENT
34 TO THE VIDEO SERVICE NETWORK IN THE HIGHWAYS WITHIN THE BOUNDARIES OF THE
35 LOCAL GOVERNMENT. THE PERMIT SHALL ALLOW INSTALLATION, OPERATION AND
36 MAINTENANCE OF ALLOWED WI-FI RADIO EQUIPMENT. A LOCAL GOVERNMENT MAY
37 REQUIRE THAT ALL OF THE ALLOWED WI-FI RADIO EQUIPMENT AT A SINGLE LOCATION
38 FIT WITHIN A FIFTEEN-INCH CUBE AND BE CONTAINED ENTIRELY WITHIN A
39 GROUND-MOUNTED PEDESTAL OR BE CONNECTED DIRECTLY TO AND MOUNTED AT THE
40 SAME HEIGHT AS ONE OF THE VIDEO SERVICE PROVIDER'S AERIAL HORIZONTAL
41 CONDUCTORS. THIS SUBSECTION DOES NOT DO ANY OF THE FOLLOWING:

42 1. PROHIBIT A LOCAL GOVERNMENT FROM REQUIRING A VIDEO SERVICE
43 PROVIDER TO PLACE UNDERGROUND AERIAL FACILITIES TO WHICH ALLOWED WI-FI
44 EQUIPMENT IS ATTACHED.

1 2. PROHIBIT THE IMPOSITION OF A TAX, RENT, FEE OR CHARGE ON REVENUE
2 FROM SERVICES PROVIDED THROUGH ALLOWED WI-FI RADIO EQUIPMENT.

3 3. AFFECT THE AUTHORITY OF A LOCAL GOVERNMENT TO MANAGE THE
4 HIGHWAYS WITHIN ITS BOUNDARIES OR TO EXERCISE ITS POLICE POWERS, INCLUDING
5 REVIEW AND APPROVAL OF AN APPLICATION BEFORE ISSUING A PERMIT.

6 4. AFFECT ANY AUTHORITY OF A POLITICAL SUBDIVISION, INCLUDING AN
7 AGRICULTURAL IMPROVEMENT DISTRICT OR ANY OTHER SPECIAL TAXING DISTRICT,
8 THE LOCAL GOVERNMENT OR ANY OTHER PERSON CONTROLLING UTILITY POLES IN THE
9 HIGHWAYS TO DENY, LIMIT, RESTRICT OR DETERMINE THE TERMS AND CONDITIONS
10 FOR THE USE OF OR ATTACHMENT TO THE UTILITY POLES OR ATTACHMENTS TO OTHER
11 POLES OF THE POLITICAL SUBDIVISION, LOCAL GOVERNMENT OR OTHER PERSON BY A
12 VIDEO SERVICE PROVIDER.

13 I. THIS SECTION DOES NOT PROHIBIT A VIDEO SERVICE PROVIDER FROM
14 AGREEING WITH A LOCAL GOVERNMENT TO PROVIDE IN-KIND SERVICES OR GOODS OR
15 MAKE IN-KIND PAYMENTS IN THE SERVICE AREA THAT ARE OTHERWISE PROHIBITED BY
16 THIS SECTION IF THE AGREEMENT WITH THE LOCAL GOVERNMENT IS NOT ENTERED
17 INTO AS A CONDITION OF OPERATING IN THE SERVICE AREA UNDER A UNIFORM VIDEO
18 SERVICE LICENSE ISSUED PURSUANT TO THIS CHAPTER. THE AGREEMENT MAY
19 AUTHORIZE THE VIDEO SERVICE PROVIDER TO RETAIN LICENSE FEES AND TAXES
20 COLLECTED FROM ITS SUBSCRIBERS IN THE AMOUNT OF ANY OFFSET TO LICENSE FEES
21 SPECIFIED IN THE AGREEMENT.

22 J. FOR THE PURPOSES OF THIS SECTION, "ALLOWED WI-FI RADIO
23 EQUIPMENT" MEANS RADIO EQUIPMENT THAT USES ONLY UNLICENSED RADIO SPECTRUM
24 AND THAT ENABLES WIRELESS COMMUNICATION WITH A COMMUNICATIONS NETWORK FOR
25 UNLICENSED SERVICES SUCH AS WI-FI SERVICE.

26 9-1443. License fee; requirements, conditions and
27 limitations; pass through to subscribers

28 A. FOR THE PRIVILEGE OF A VIDEO SERVICE PROVIDER TO OCCUPY OR USE,
29 IN WHOLE OR IN PART, ANY HIGHWAY WITHIN THE BOUNDARIES OF A LOCAL
30 GOVERNMENT TO PROVIDE VIDEO SERVICE THROUGH A VIDEO SERVICE NETWORK, THE
31 LOCAL GOVERNMENT MAY REQUIRE A VIDEO SERVICE PROVIDER TO PAY A LICENSE FEE
32 TO THE LOCAL GOVERNMENT BASED ON THE GROSS REVENUE THAT THE VIDEO SERVICE
33 PROVIDER RECEIVES FROM ITS SUBSCRIBERS LOCATED WITHIN THE BOUNDARIES OF
34 THE LOCAL GOVERNMENT. THE LICENSE FEE BOTH:

35 1. IS SUBJECT TO THE LIMIT PRESCRIBED IN SECTION 9-1442, SUBSECTION
36 B AND TO OFFSET, INCLUDING AMOUNTS COLLECTED FROM SUBSCRIBERS, AS
37 PRESCRIBED BY SECTION 9-1442, SUBSECTIONS A AND I AND SUBSECTION D OF THIS
38 SECTION.

39 2. SHALL BE DUE NO MORE OFTEN THAN QUARTERLY.

40 B. IF THE LOCAL GOVERNMENT REQUIRES A LICENSE FEE PURSUANT TO
41 SUBSECTION A OF THIS SECTION, THE LOCAL GOVERNMENT SHALL ADOPT A LOCAL LAW
42 THAT IMPOSES THE LICENSE FEE EQUALLY AND UNIFORMLY ON ALL OF THE FOLLOWING
43 THAT ARE OPERATING WITHIN THE BOUNDARIES OF THE LOCAL GOVERNMENT:

- 44 1. VIDEO SERVICE PROVIDERS.
45 2. HOLDOVER CABLE OPERATORS.

1 C. A VIDEO SERVICE PROVIDER SHALL PAY THE ENTIRE AMOUNT OF THE
2 LICENSE FEE DIRECTLY TO THE LOCAL GOVERNMENT IN A CHECK, DRAFT OR NOTE OR
3 AUTOMATED CLEARING HOUSE TRANSACTION THAT IS PAYABLE IN LEGAL TENDER AS
4 DEFINED IN SECTION 43-1021.

5 D. A VIDEO SERVICE PROVIDER MAY DO ALL OF THE FOLLOWING:

6 1. PASS THE LICENSE FEE THROUGH TO AND COLLECT THE LICENSE FEE FROM
7 ITS SUBSCRIBERS WITHIN THE BOUNDARIES OF THE LOCAL GOVERNMENT, INCLUDING
8 FOR AN INCUMBENT CABLE OPERATOR ANY CHANGE IN LICENSE FEES THAT RESULTS
9 FROM A CHANGE IN THE APPLICABLE DEFINITION OF GROSS REVENUE.

10 2. DESIGNATE THE AMOUNT OF THE LICENSE FEE COLLECTED FROM EACH
11 SUBSCRIBER AS A SEPARATE LINE ITEM ON THE SUBSCRIBER'S BILL.

12 9-1444. Ownership of a video service network

13 A. A CITY OR TOWN MAY NOT ACQUIRE AN OWNERSHIP INTEREST IN A VIDEO
14 SERVICE NETWORK UNLESS THE OWNERSHIP INTEREST IS ACQUIRED AT NOT LESS THAN
15 FAIR MARKET VALUE.

16 B. EXCEPT FOR THE PURPOSES OF ACTING AS AN INTERMEDIARY IN A
17 TRANSFER OF A UNIFORM VIDEO SERVICE LICENSE, A COUNTY MAY NOT OWN A VIDEO
18 SERVICE NETWORK.

19 9-1445. Review and audit; bundling discounts; action to
20 recover underpayment or overpayment

21 A. NOT MORE THAN ONCE EVERY THREE YEARS, A LOCAL GOVERNMENT MAY ON
22 REASONABLE WRITTEN NOTICE AUDIT THE BUSINESS BOOKS AND RECORDS OF A VIDEO
23 SERVICE PROVIDER TO THE EXTENT NECESSARY TO ENSURE PAYMENT OF LICENSE FEES
24 PURSUANT TO THIS CHAPTER. THE LOCAL GOVERNMENT MAY NOT AUDIT ANY PERIOD
25 THAT ENDS MORE THAN THREE YEARS BEFORE THE DATE THAT THE NOTICE OF AUDIT
26 IS RECEIVED. ANY AUDITS OF A PERIOD OF TIME BEFORE ISSUANCE OF A UNIFORM
27 VIDEO SERVICE LICENSE SHALL BE CONDUCTED PURSUANT TO THE LOCAL LAWS IN
28 EFFECT DURING THE PERIOD OF TIME.

29 B. EXCEPT AS OTHERWISE PROVIDED BY FEDERAL LAW, IF A VIDEO SERVICE
30 PROVIDER OFFERS VIDEO SERVICE BUNDLED WITH OTHER SERVICES THAT ARE NOT
31 VIDEO SERVICE FOR A SINGLE DISCOUNTED PRICE, ALL OF THE FOLLOWING APPLY:

32 1. THE METHOD THAT THE VIDEO SERVICE PROVIDER USES TO DETERMINE
33 GROSS REVENUE SUBJECT TO LICENSE FEES BY ALLOCATING THE SINGLE DISCOUNTED
34 PRICE AMONG THE BUNDLE OF VIDEO SERVICE AND NONVIDEO SERVICES SHALL BE
35 REASONABLE AND SUPPORTED BY THE VIDEO SERVICE PROVIDER'S BOOKS AND
36 RECORDS.

37 2. THE LOCAL GOVERNMENT SHALL ACCEPT AS REASONABLE, FOR PURPOSES OF
38 MEETING THE VIDEO SERVICE PROVIDER'S BURDEN OF PROOF, AN ALLOCATION BASED
39 ON AN OBJECTIVE AND VERIFIABLE METHOD USING THE BOOKS AND RECORDS THAT THE
40 VIDEO SERVICE PROVIDER KEPT IN THE REGULAR COURSE OF BUSINESS FOR OTHER
41 PURPOSES, INCLUDING NONTAX PURPOSES.

42 3. A VIDEO SERVICE PROVIDER MAY NOT USE BUNDLED OFFERINGS AS A
43 MEANS TO EVADE PAYING LICENSE FEES.

44 C. THE LOCAL GOVERNMENT AND THE VIDEO SERVICE PROVIDER SHALL EACH
45 PAY ITS OWN COSTS AND FEES RELATING TO EACH AUDIT PERFORMED PURSUANT TO

1 SUBSECTION A OF THIS SECTION. IF THE SUM DETERMINED TO BE UNDERPAID
2 EXCEEDS FIVE PERCENT OF THE TOTAL FEES THAT THE AUDIT DETERMINES SHOULD
3 HAVE BEEN PAID FOR THE PERIOD, THE VIDEO SERVICE PROVIDER SHALL PAY THE
4 LOCAL GOVERNMENT'S REASONABLE COSTS OF THE AUDIT.

5 D. THE RATE OF INTEREST FOR BOTH UNDERPAYMENTS AND OVERPAYMENTS IS
6 THE FEDERAL SHORT-TERM RATE DETERMINED PURSUANT TO 26 UNITED STATES CODE
7 SECTION 6621(b), PLUS THREE PERCENTAGE POINTS.

8 E. A PERSON THAT PERFORMS A REVIEW AND AUDIT UNDER SUBSECTION A OF
9 THIS SECTION MAY NOT RECEIVE COMPENSATION THAT IS BASED, IN WHOLE OR IN
10 PART, ON EITHER OF THE FOLLOWING:

11 1. FINDING A PARTICULAR RESULT.

12 2. THE AMOUNT OF ANY UNDERPAYMENT OR OVERPAYMENT OF THE LICENSE FEE
13 THAT IS IDENTIFIED BECAUSE OF THE REVIEW AND AUDIT.

14 F. A COMPLAINT BY A LOCAL GOVERNMENT FOR UNDERPAYMENT OF A LICENSE
15 FEE FROM A VIDEO SERVICE PROVIDER OR BY A VIDEO SERVICE PROVIDER FOR
16 OVERPAYMENT OF A LICENSE FEE TO A LOCAL GOVERNMENT SHALL BE MADE PURSUANT
17 TO ARTICLE 5 OF THIS CHAPTER.

18 G. A COMPLAINT FOR A VIOLATION OF THE LICENSE FEE OBLIGATIONS UNDER
19 THIS CHAPTER MAY NOT BE MADE UNLESS A WRITTEN DEMAND BY A LOCAL GOVERNMENT
20 FOR PAYMENT OF THE LICENSE FEES OR A WRITTEN DEMAND BY A VIDEO SERVICE
21 PROVIDER FOR REFUND OF LICENSE FEES IS MADE WITHIN FOUR MONTHS AFTER THE
22 LOCAL GOVERNMENT OR VIDEO SERVICE PROVIDER REALIZES IT HAS BEEN DAMAGED OR
23 KNOWS OR REASONABLY SHOULD KNOW OF THE DAMAGE CAUSED BY THE ALLEGED
24 VIOLATION.

25 H. A COMPLAINT MUST BE FILED PURSUANT TO ARTICLE 5 OF THIS CHAPTER
26 WITHIN TWO YEARS AFTER THE WRITTEN DEMAND IS MADE PURSUANT TO THIS
27 SUBSECTION BUT NOT SOONER THAN FOUR MONTHS AFTER THE WRITTEN DEMAND.

28 ARTICLE 5. ENFORCEMENT

29 9-1451. Enforcement; office of administrative hearings; fees;
30 fund

31 A. A LOCAL GOVERNMENT MAY FILE A WRITTEN COMPLAINT AGAINST A VIDEO
32 SERVICE PROVIDER AND A VIDEO SERVICE PROVIDER MAY FILE A WRITTEN COMPLAINT
33 AGAINST A LOCAL GOVERNMENT ALLEGING A VIOLATION OF THIS CHAPTER OR THE
34 UNIFORM VIDEO SERVICE LICENSE AGREEMENT. UNLESS OTHERWISE PROVIDED IN
35 SECTION 9-1445, SUBSECTIONS F, G AND H OR THIS SECTION:

36 1. ALL COMPLAINTS MUST BE FILED WITH THE OFFICE OF ADMINISTRATIVE
37 HEARINGS.

38 2. THE COMPLAINANT MUST SERVE A COPY OF THE COMPLAINT ON THE PARTY
39 THAT IS THE SUBJECT OF THE COMPLAINT BY PERSONAL DELIVERY OR CERTIFIED
40 MAIL, RETURN RECEIPT REQUESTED, OR BY ANY OTHER METHOD REASONABLY
41 CALCULATED TO EFFECT ACTUAL NOTICE TO THE LOCAL GOVERNMENT'S LAST ADDRESS
42 OF RECORD FOR THE PARTY THAT IS THE SUBJECT OF THE COMPLAINT.

43 3. THE PARTY THAT IS THE SUBJECT OF THE COMPLAINT MAY FILE A
44 RESPONSE TO THE COMPLAINT WITH THE OFFICE OF ADMINISTRATIVE HEARINGS
45 WITHIN TWENTY DAYS AFTER SERVICE PURSUANT TO PARAGRAPH 2 OF THIS

1 SUBSECTION. RESPONSES SHALL BE SERVED PURSUANT TO PARAGRAPH 2 OF THIS
2 SUBSECTION.

3 B. BEFORE FILING A COMPLAINT PURSUANT TO THIS SECTION ALL OF THE
4 FOLLOWING APPLY:

5 1. THE COMPLAINANT MUST PROVIDE NOTICE OF THE ALLEGED VIOLATION OF
6 THIS CHAPTER TO THE PARTY THAT IS THE SUBJECT OF THE COMPLAINT.

7 2. THE PARTY THAT IS THE SUBJECT OF THE COMPLAINT MUST HAVE A
8 PERIOD OF NOT LESS THAN TWENTY DAYS AFTER THE DATE IT RECEIVES THE NOTICE
9 TO RESOLVE THE ALLEGED VIOLATION.

10 C. A HEARING BEFORE THE OFFICE OF ADMINISTRATIVE HEARINGS SHALL BE
11 HELD IF A COMPLAINT THAT COMPLIES WITH THIS SECTION IS FILED WITH THE
12 OFFICE OF ADMINISTRATIVE HEARINGS. UNLESS OTHER DEADLINES ARE ESTABLISHED
13 FOR A PARTICULAR COMPLAINT, ALL OF THE FOLLOWING APPLY:

14 1. THE HEARING SHALL BE HELD WITHIN TWO MONTHS AFTER THE DATE THAT
15 THE COMPLAINT IS FILED AND SERVICE IS COMPLETED PURSUANT TO SUBSECTION A
16 OF THIS SECTION.

17 2. THE DATE SCHEDULED FOR THE HEARING MAY BE ADVANCED OR DELAYED ON
18 THE AGREEMENT OF THE PARTIES OR ON A SHOWING OF GOOD CAUSE.

19 D. THE OFFICE OF ADMINISTRATIVE HEARINGS SHALL PREPARE AND SERVE A
20 NOTICE OF HEARING ON ALL PARTIES AT LEAST ONE MONTH BEFORE THE HEARING
21 THAT STATES THE TIME AND PLACE OF THE HEARING.

22 E. A PREHEARING CONFERENCE MAY BE HELD PURSUANT TO SECTION
23 41-1092.05.

24 F. UNLESS IT CONFLICTS WITH THE REQUIREMENTS OF THIS SECTION, THE
25 HEARING SHALL BE CONDUCTED PURSUANT TO SECTION 41-1092.07.

26 G. THE COMPLAINANT HAS THE BURDEN OF PERSUASION AT A HEARING UNDER
27 THIS SECTION.

28 H. THE DECISION OF THE ADMINISTRATIVE LAW JUDGE IS THE FINAL
29 ADMINISTRATIVE DECISION WITH RESPECT TO THE COMPLAINT. THE OFFICE OF
30 ADMINISTRATIVE HEARINGS SHALL SERVE A COPY OF THE ADMINISTRATIVE LAW
31 JUDGE'S DECISION ON ALL PARTIES. THE FINAL ADMINISTRATIVE DECISION MAY BE
32 APPEALED TO THE SUPERIOR COURT PURSUANT TO TITLE 12, CHAPTER 7, ARTICLE 6.
33 NOTWITHSTANDING SECTION 12-910, THE SUPERIOR COURT PROCEEDING SHALL BE A
34 TRIAL DE NOVO.

35 I. A PARTY MAY MOVE FOR REHEARING PURSUANT TO SECTION 41-1092.09
36 AND THE OFFICE OF ADMINISTRATIVE HEARINGS SHALL RULE ON THE MOTION. MOVING
37 FOR REHEARING OR REVIEW IS NOT NECESSARY FOR THE PARTY TO SEEK JUDICIAL
38 REVIEW OF THE DECISION OF THE ADMINISTRATIVE LAW JUDGE UNDER SUBSECTION H
39 OF THIS SECTION.

40 J. SERVICE IS COMPLETE ON PERSONAL SERVICE OR FIVE DAYS AFTER THE
41 DATE THAT THE OFFICE OF ADMINISTRATIVE HEARINGS MAILES THE FINAL
42 ADMINISTRATIVE DECISION TO EACH PARTY'S LAST KNOWN ADDRESS OF RECORD WITH
43 THE LOCAL GOVERNMENT.

44 K. THE OFFICE OF ADMINISTRATIVE HEARINGS SHALL ADOPT RULES PURSUANT
45 TO TITLE 41, CHAPTER 6 TO ADMINISTER HEARINGS UNDER THIS CHAPTER.

1 L. THE OFFICE OF ADMINISTRATIVE HEARINGS SHALL ESTABLISH,
2 ADMINISTER AND COLLECT FEES IN AN AMOUNT TO BE DETERMINED BY THE DIRECTOR
3 OF THE OFFICE OF ADMINISTRATIVE HEARINGS. THE DIRECTOR SHALL DEPOSIT,
4 PURSUANT TO SECTIONS 35-146 AND 35-147, ALL MONIES IN THE VIDEO SERVICE
5 PROVIDER COMPLAINT FUND ESTABLISHED BY SUBSECTION M OF THIS SECTION.

6 M. THE VIDEO SERVICE PROVIDER COMPLAINT FUND IS ESTABLISHED
7 CONSISTING OF MONIES COLLECTED PURSUANT TO SUBSECTION L OF THIS SECTION.
8 THE OFFICE OF ADMINISTRATIVE HEARINGS SHALL ADMINISTER THE FUND. MONIES
9 IN THE FUND ARE CONTINUOUSLY APPROPRIATED. THE OFFICE OF ADMINISTRATIVE
10 HEARINGS SHALL USE THE MONIES IN THE FUND FOR THE PURPOSE OF ADMINISTERING
11 THE DUTIES SPECIFIED IN THIS ARTICLE.

12 9-1452. Statute of limitations; costs and attorney fees;
13 federal subscriber service requirements

14 A. EXCEPT AS PROVIDED IN SECTION 9-1445, SUBSECTIONS F, G AND H, A
15 COMPLAINT UNDER THIS ARTICLE MUST BE FILED WITHIN TWO YEARS AFTER THE
16 COMPLAINANT REALIZES IT HAS BEEN DAMAGED AND KNOWS OR REASONABLY SHOULD
17 KNOW THE CAUSE, SOURCE, ACT, EVENT, INSTRUMENTALITY OR CONDITION THAT
18 CAUSED OR CONTRIBUTED TO THE ALLEGED VIOLATION.

19 B. EACH PARTY TO A DISPUTE UNDER THIS CHAPTER SHALL BEAR ITS OWN
20 ATTORNEY FEES AND COSTS.

21 C. THIS ARTICLE DOES NOT APPLY TO CLAIMS THAT A VIDEO SERVICE
22 PROVIDER HAS FAILED TO MEET SUBSCRIBER SERVICE STANDARDS PRESCRIBED BY
23 SECTION 9-1433, SUBSECTION B, PARAGRAPH 5 OR HAS VIOLATED TITLE 44,
24 CHAPTER 10, ARTICLE 7. CLAIMS OF VIOLATIONS OF FEDERAL SUBSCRIBER SERVICE
25 STANDARDS SHALL BE MADE PURSUANT TO THE PROCEDURE ESTABLISHED UNDER
26 FEDERAL LAW.

27 Sec. 2. Section 41-1092.01, Arizona Revised Statutes, is amended to
28 read:

29 41-1092.01. Office of administrative hearings; director;
30 powers and duties; fund

31 A. An office of administrative hearings is established.

32 B. The governor shall appoint the director pursuant to section
33 38-211. At a minimum, the director shall have the experience necessary for
34 appointment as an administrative law judge. The director also shall
35 possess supervisory, management and administrative skills, as well as
36 knowledge and experience relating to administrative law.

37 C. The director shall:

38 1. Serve as the chief administrative law judge of the office.

39 2. Make and execute the contracts and other instruments that are
40 necessary to perform the director's duties.

41 3. Subject to chapter 4, article 4 of this title, hire employees,
42 including full-time administrative law judges, and contract for special
43 services, including temporary administrative law judges, that are
44 necessary to carry out this article. An administrative law judge employed
45 or contracted by the office shall have graduated from an accredited

1 college of law or shall have at least two years of administrative or
2 managerial experience in the subject matter or agency section the
3 administrative law judge is assigned to in the office.

4 4. Make rules that are necessary to carry out this article,
5 including rules governing ex parte communications in contested cases.

6 5. Submit a report to the governor, speaker of the house of
7 representatives and president of the senate by November 1 of each year
8 describing the activities and accomplishments of the office. The
9 director's annual report shall include a summary of the extent and effect
10 of agencies' utilization of administrative law judges, court reporters and
11 other personnel in proceedings under this article and recommendations for
12 changes or improvements in the administrative procedure act or any
13 agency's practice or policy with respect to the administrative procedure
14 act.

15 6. Secure, compile and maintain all decisions, opinions or reports
16 of administrative law judges issued pursuant to this article and the
17 reference materials and supporting information that may be appropriate.

18 7. Develop, implement and maintain a program for the continuing
19 training and education of administrative law judges and agencies in regard
20 to their responsibilities under this article. The program shall require
21 that an administrative law judge receive training in the technical and
22 subject matter areas of the sections to which the administrative law judge
23 is assigned.

24 8. Develop, implement and maintain a program of evaluation to aid
25 the director in the evaluation of administrative law judges appointed
26 pursuant to this article that includes comments received from the public.

27 9. Annually report the following to the governor, the president of
28 the senate and the speaker of the house of representatives by December 1
29 for the prior fiscal year:

30 (a) The number of administrative law judge decisions rejected or
31 modified by agency heads.

32 (b) By category, the number and disposition of motions filed
33 pursuant to section 41-1092.07, subsection A to disqualify office
34 administrative law judges for bias, prejudice, personal interest or lack
35 of expertise.

36 (c) By agency, the number and type of violations of section
37 41-1009.

38 10. Schedule hearings pursuant to section 41-1092.05 upon the
39 request of an agency or the filing of a notice of appeal pursuant to
40 section 41-1092.03.

41 D. The director shall not require legal representation to appear
42 before an administrative law judge.

43 E. Except as provided in subsection F of this section, all state
44 agencies supported by state general fund sources, unless exempted by this
45 article, and the registrar of contractors shall use the services and

1 personnel of the office to conduct administrative hearings. All other
2 agencies shall contract for services and personnel of the office to
3 conduct administrative hearings.

4 F. An agency head, board or commission that directly conducts an
5 administrative hearing as an administrative law judge is not required to
6 use the services and personnel of the office for that hearing.

7 G. Each state agency, and each political subdivision contracting
8 for office services pursuant to subsection I of this section, shall make
9 its facilities available, as necessary, for use by the office in
10 conducting proceedings pursuant to this article.

11 H. The office shall employ full-time administrative law judges to
12 conduct hearings required by this article or other laws as follows:

13 1. The director shall assign administrative law judges from the
14 office to an agency, on either a temporary or a permanent basis, at
15 supervisory or other levels, to preside over contested cases and
16 appealable agency actions in accordance with the special expertise of the
17 administrative law judge in the subject matter of the agency.

18 2. The director shall establish the subject matter and agency
19 sections within the office that are necessary to carry out this
20 article. Each subject matter and agency section shall provide training in
21 the technical and subject matter areas of the section as prescribed in
22 subsection C, paragraph 7 of this section.

23 I. If the office cannot furnish an office administrative law judge
24 promptly in response to an agency request, the director may contract with
25 qualified individuals to serve as temporary administrative law
26 judges. These temporary administrative law judges are not employees of
27 this state.

28 J. The office may provide administrative law judges on a contract
29 basis to any governmental entity to conduct any hearing not covered by
30 this article. The director may enter into contracts with political
31 subdivisions of this state, and these political subdivisions may contract
32 with the director for the purpose of providing administrative law judges
33 and reporters for administrative proceedings or informal dispute
34 resolution. The contract may define the scope of the administrative law
35 judge's duties. Those duties may include the preparation of findings,
36 conclusions, decisions or recommended decisions or a recommendation for
37 action by the political subdivision. For these services, the director
38 shall request payment for services directly from the political subdivision
39 for which the services are performed, and the director may accept payment
40 on either an advance or reimbursable basis.

41 K. The office shall apply monies received pursuant to subsections E
42 and J of this section to offset its actual costs for providing personnel
43 and services.

1 L. THE OFFICE SHALL RECEIVE COMPLAINTS AGAINST A LOCAL GOVERNMENT
2 OR VIDEO SERVICE PROVIDER AS DEFINED IN SECTION 9-1401 AND SHALL COMPLY
3 WITH THE DUTIES IMPOSED ON THE OFFICE PURSUANT TO TITLE 9, CHAPTER 13.

4 Sec. 3. Legislative findings

5 Pursuant to section 41-1107, Arizona Revised Statutes, the
6 legislature has determined that it is reasonable and necessary to promote
7 a matter of statewide concern by regulating the licensure and provision of
8 video service to promote all of the following:

9 1. Provision of competitive video, telecommunications and
10 information service throughout this state.

11 2. More uniform regulation of competitive video service throughout
12 this state.

13 3. Streamlined licensing by local governments and more uniform
14 terms and conditions for video service providers that use highways to
15 provide video and other services over video service networks.

16 4. Continued management of local governments' use of their highways
17 with reasonable burdens on construction and maintenance across boundaries
18 between local governments for video service providers to use highways.

19 5. Continued levying of license fees by local governments on
20 subscriber service revenues derived from operating video service networks
21 to provide video service.

22 6. Support for federal subscriber service standards.

APPROVED BY THE GOVERNOR MAY 16, 2018.

FILED IN THE OFFICE OF THE SECRETARY OF STATE MAY 16, 2018.

State of Arizona
House of Representatives
Fifty-fourth Legislature
First Regular Session
2019

CHAPTER 76
HOUSE BILL 2229

AN ACT

AMENDING SECTIONS 9-1401, 9-1415, 9-1441, 9-1442, 9-1444, 9-1445 AND 9-1451, ARIZONA REVISED STATUTES; AMENDING TITLE 11, ARIZONA REVISED STATUTES, BY ADDING CHAPTER 14; AMENDING SECTION 41-1092.01, ARIZONA REVISED STATUTES; RELATING TO VIDEO SERVICE PROVIDERS.

(TEXT OF BILL BEGINS ON NEXT PAGE)

1 Be it enacted by the Legislature of the State of Arizona:
2 Section 1. Section 9-1401, Arizona Revised Statutes, is amended to
3 read:
4 9-1401. Definitions
5 In this chapter, unless the context otherwise requires:
6 1. "Affiliate" means a person that directly or indirectly, through
7 one or more intermediaries, controls, is controlled by or is under common
8 control with a video service provider.
9 2. "Agreement" means any agreement or contract.
10 3. "Boundaries of a local government" or "boundaries" means:
11 ~~(a) For a city or town, all of the area within the corporate limits~~
12 ~~of the city or town.~~
13 ~~(b) For a county, all of the area of the county that is not within~~
14 ~~the corporate limits of any city or town, including unincorporated~~
15 ~~territory that is surrounded on all sides by a combination of one or more~~
16 ~~cities, towns or Indian reservations.~~
17 4. "Cable operator" has the same meaning prescribed in 47 United
18 States Code section 522.
19 5. "Cable service" has the same meaning prescribed in 47 United
20 States Code section 522.
21 6. "Cable system" has the same meaning prescribed in 47 United
22 States Code section 522.
23 7. "Commercial mobile service provider" means a person that
24 provides commercial mobile service as defined in 47 United States Code
25 section 332(d) or commercial mobile radio service as described in 47 Code
26 of Federal Regulations section ~~20.9~~ 20.3.
27 8. "Day" means a calendar day, except a Saturday or Sunday or a
28 holiday prescribed in section 1-301.
29 9. "Gross revenue":
30 (a) Means all cash, credits, property of any kind or nature or
31 other consideration that is received directly or indirectly by a video
32 service provider, its affiliates, or any person, firm or corporation in
33 which the video service provider has a financial interest or that has a
34 financial interest in the video service provider and that is derived from
35 the video service provider's operation of its video service network to
36 provide video service in the service area.
37 (b) Includes all revenue from charges for video service to
38 subscribers and all charges for installation, removal, connection or
39 reinstatement of equipment necessary for a subscriber to receive video
40 service and any other receipts from subscribers derived from the video
41 service provider's operation of the video service network to provide video
42 service, including receipts from forfeited deposits, sale or rental of
43 equipment to provide video service, late charges, interest and sale of
44 program guides.

- 1 (c) Does not include:
- 2 (i) Any revenue not received, even if billed, such as bad debt net
- 3 of any recoveries of bad debt or any refunds, credits, allowances or
- 4 discounts to subscribers to the extent that the refund, rebate, credit,
- 5 allowance or discount is attributed to video service.
- 6 (ii) Revenue from commercial advertising on the video service
- 7 network, the use or lease of studio facilities of the video service
- 8 network, internet access service, the use or lease of its facilities
- 9 located in the highways, the use or lease of leased access channels or
- 10 bandwidth, the use or lease of towers, the production of video programming
- 11 by the video service provider, the sale, exchange, use or cablecast of any
- 12 programming by the video service provider in the service area, sales to
- 13 the video service provider's subscribers by programmers of home shopping
- 14 services, reimbursements paid by programmers for launch fees or marketing
- 15 expenses, license fees, taxes or other fees or charges that the video
- 16 service provider collects and pays to any governmental authority, any
- 17 increase in the value of any stock, security or asset, or any dividends or
- 18 other distributions made from any stock or securities.
- 19 10. "Highway" means all roads, streets and alleys and other
- 20 dedicated public rights-of-way that are operated and maintained by a local
- 21 government.
- 22 11. "Holder" means a video service provider that has been issued a
- 23 uniform video service license pursuant to this chapter.
- 24 12. "Holdover cable operator" means an incumbent cable operator
- 25 that elects under sections 9-1412 and 9-1413 to continue to operate within
- 26 its service area pursuant to its local license.
- 27 13. "Incumbent cable operator" means a cable operator or other
- 28 video service provider that on December 31, 2019 is providing video
- 29 service in this state pursuant to a local license.
- 30 14. "Information service" has the same meaning prescribed in 47
- 31 United States Code section 153.
- 32 15. "Interactive computer service" has the same meaning prescribed
- 33 in 47 United States Code section 230(f).
- 34 16. "License" means a franchise as defined in 47 United States Code
- 35 section 522.
- 36 17. "License fee" means a license fee imposed by a local government
- 37 on a video service provider for using the highways to provide and for the
- 38 privilege of providing video service.
- 39 18. "Local government" means any city, including a charter city, **OR**
- 40 town ~~or county~~.
- 41 19. "Local law" means any charter, code, ordinance, resolution,
- 42 regulation or other law of a local government.
- 43 20. "Local license" means any license, agreement, permit or similar
- 44 authorization that meets all of the following:

1 (a) Allows a person to construct or operate a video service network
2 within the boundaries of a local government.

3 (b) Is issued, granted, approved, extended or renewed by the local
4 government before January 1, 2020 pursuant to the authority of any
5 federal, state or local law in effect at the time of the issuance, grant,
6 approval, extension or renewal.

7 (c) Is effective under federal, state or local law on December 31,
8 2019 for the person to continue to construct or operate a video service
9 network within the boundaries of a local government.

10 21. "Multichannel video programming distributor" has the same
11 meaning prescribed in 47 United States Code section 522.

12 22. "Service area" means that part of the boundaries of a local
13 government within which a video service provider is authorized to provide
14 video service pursuant to a uniform video service license or a local
15 license.

16 23. "Subscriber" means any person in this state that purchases
17 video service. Subscriber does not include any person that purchases
18 video service for resale and that, on resale, is required to pay a license
19 fee pursuant to this chapter or the terms of a local license.

20 24. "Telecommunications":

21 (a) Means the transmission, between or among points specified by
22 the user, of information of the user's choosing, without change in the
23 form or content of the information sent and received, regardless of the
24 facilities, equipment or technology used.

25 (b) Does not include commercial mobile radio service, pay phone
26 service, interstate service or cable service.

27 25. "Telecommunications provider" means a person that is required
28 to obtain from the corporation commission a certificate of public
29 convenience and necessity to provide telecommunications service.

30 26. "Telecommunications service" means the offering of
31 telecommunications for a fee directly to the public, or to such users as
32 to be effectively available directly to the public, regardless of the
33 equipment, facilities or technology used.

34 27. "Uniform video service license" means a license that is issued
35 by a local government in the form of a uniform video service license
36 agreement as adopted pursuant to section 9-1411.

37 28. "Video service":

38 (a) Means the provision of multichannel video programming generally
39 considered comparable to video programming delivered by a television
40 broadcast station, video service or other digital television service,
41 whether provided as part of a tier, on demand or on a per-channel basis,
42 without regard to the technology used to deliver the video service,
43 including internet protocol technology or any successor technology.

44 (b) Includes cable service.

1 (c) Does not include any of the following:

2 (i) Video programming provided solely as part of, and through, a
3 service that enables users to access content, information, e-mail,
4 messaging or other services that are offered via the public internet.

5 (ii) Direct broadcast satellite service.

6 (iii) Wireless multichannel video programming that is provided by a
7 commercial mobile service provider.

8 29. "Video service network":

9 (a) Means a wireline network, or any component of a wireline
10 network, that is located in this state, constructed in whole or in part
11 in, on, under or over any highway and used to provide video service.

12 (b) Includes a cable system.

13 30. "Video service provider":

14 (a) Means any person that provides or offers to provide video
15 service over a video service network to subscribers in this state.

16 (b) Includes an incumbent cable operator that elected pursuant to
17 sections 9-1412 and 9-1413 to terminate its local license and a
18 multichannel video programming distributor.

19 (c) Does not include a holdover cable operator.

20 Sec. 2. Section 9-1415, Arizona Revised Statutes, is amended to
21 read:

22 9-1415. Authority granted by uniform video service license;
23 conditions and limitations prohibited; providing
24 video service

25 A. Not later than thirty days after the date an applicant files a
26 completed application and affidavit pursuant to section 9-1414, the local
27 government shall issue a uniform video service license to the applicant in
28 the form prescribed by section 9-1411. If the local government does not
29 notify the applicant about the completeness of the uniform video service
30 license agreement within the time period prescribed by section 9-1414,
31 subsection D or issue the agreement within the time period required under
32 this subsection, the agreement shall be considered complete and issued to
33 the applicant in the form submitted.

34 B. The uniform video service license issued to an applicant,
35 including an incumbent cable operator, by a local government is a
36 nonexclusive license granting to the holder of the uniform video service
37 license the authority for the term requested in the application to do all
38 of the following:

39 1. Provide video service in all service areas designated in the
40 application and affidavit filed with the local government.

41 2. Construct and operate a video service network in the highways in
42 each service area in compliance with this chapter and all local laws that
43 ~~are not in conflict or otherwise do not~~ conform to this chapter ~~or~~ AND the
44 purposes and objectives of this chapter.

1 ~~3. Operate and maintain facilities installed in the highways in the~~
2 ~~service area under a local license pursuant to all of the following:~~

3 ~~(a) Section 9-506, subsections I and J.~~

4 ~~(b) Section 9-584.~~

5 ~~(c) Chapter 5, article 8 of this title and title 11, chapter 13,~~
6 ~~article 1.~~

7 C. A local government may not condition or limit a uniform video
8 service license by imposing any obligation or requirement that is not
9 authorized by this chapter, including any of the following:

10 1. Any office location, institutional network or other build-out,
11 line extension, investment or other requirements relating to the overall
12 scope, extent and timing of infrastructure, facilities or deployment of
13 equipment.

14 2. Any requirements to pay to any person any application, document,
15 license, service or other fee, tax, charge or assessment that is not
16 authorized by this chapter.

17 D. A holder of a uniform video service license shall provide video
18 service in accordance with the certifications made by the holder in each
19 application and affidavit that the holder files with a local government
20 pursuant to this article.

21 Sec. 3. Section 9-1441, Arizona Revised Statutes, is amended to
22 read:

23 9-1441. Management of highways; local governments; permits or
24 licenses

25 A. In managing a highway under local laws as prescribed in section
26 9-1411, subsection C, paragraph 9, a local government may manage the use
27 of the highway, including all of the following:

28 1. Requiring a video service provider that is constructing,
29 installing, working within, maintaining or repairing facilities in, on,
30 under or over any highway to obtain a construction, encroachment or
31 occupancy permit for the work.

32 2. Inspecting the construction, installation, maintenance or repair
33 work performed on such facilities.

34 3. Limiting the installation of new aerial facilities.

35 B. If a video service provider requests a permit or inspection, the
36 local government shall grant or deny the request within the time frame
37 that the local government has in place under section 9-835 ~~or 11-1605~~.

38 C. If emergency response work or repair becomes necessary in, on,
39 under or over any highway, a video service provider may begin that work or
40 repair without prior approval from a local government if the video service
41 provider notifies the local government as promptly as reasonably possible
42 after learning that the work or repair is necessary.

1 Sec. 4. Section 9-1442, Arizona Revised Statutes, is amended to
2 read:

3 9-1442. Fees and charges; emergency alert; damage;
4 undergrounding; wireless facilities; definition

5 A. Except the license fee on gross revenue authorized by section
6 9-1443 and transaction privilege taxes as provided in subsection B of this
7 section, a local government may not levy a tax, rent, fee or charge,
8 however denominated, on a video service provider for the use of the
9 highways to provide video service or levy a tax, fee or charge on the
10 privilege of engaging in the business of providing video service in the
11 service area. Taxes, rents, fees and charges include all of the
12 following:

13 1. Access channel support except for in-kind services, goods or
14 payments as provided in subsection C of this section.

15 2. Rental, application, construction, permit, inspection,
16 inconvenience and other fees and charges related to a video service
17 provider's use of the highways, including the use authorized by subsection
18 D of this section except that a local government may impose on a video
19 service provider some or all of the fees and charges described in this
20 paragraph. A video service provider shall offset the fees and charges
21 imposed pursuant to this paragraph against the next license fee payment
22 made pursuant to section 9-1443.

23 B. Any transaction privilege taxes otherwise authorized by local
24 law to be levied on the business of providing video service or in relation
25 to use of the highways to provide video service may be levied on a video
26 service provider if the taxes are levied only on gross revenue and the
27 rate of the taxes is subject to this subsection. This subsection does not
28 authorize the imposition of transaction privilege taxes on interstate
29 telecommunications service. The license fee and any transaction privilege
30 taxes levied on gross revenue constitute a franchise fee within the
31 meaning of the term in 47 United States Code section 542(g). The total of
32 the rates of the license fee and of any transaction privilege taxes on
33 gross revenue levied or assessed by a local government for the privilege
34 of providing video service and related use of the highways to provide
35 video service may not exceed a rate of five percent.

36 C. Subsection A of this section does not prohibit a local
37 government from levying fees and charges on a video service provider or
38 its affiliates pursuant to section 9-584 or pursuant to chapter 5, article
39 8 of this title ~~or title 11, chapter 13, article 1~~ without an offset
40 against license fees.

41 D. A local government may not require a video service provider to
42 provide in-kind goods or services, make in-kind payments, assessments or
43 obligations or pay a fee in addition to the monetary license fee levied or
44 assessed as provided in section 9-1443, except for any of the following:

1 1. A local law may impose and enforce obligations equally and
2 uniformly on all video service providers that are operating within the
3 boundaries of a local government and on all holdover cable operators that
4 hold a local license that remains in effect under section 9-1414,
5 subsection A. Under the local law, a local government:

6 (a) May require all video service providers to provide channel
7 capacity for the video service provider to transmit programming over which
8 the video service provider exercises no editorial control except as
9 authorized by 47 United States Code section 531(e). The channel capacity
10 shall be limited to one of the following:

11 (i) Not more than two channels of public, educational or
12 governmental access programming in the basic service tier of the video
13 service network and not more than two channels of noncommercial
14 governmental programming, at least one of which may be programmed by the
15 federal government, in the digital programming tier of the video service
16 network.

17 (ii) Not more than two lines of access programming with each line
18 of programming carried on up to two standard definition channels and two
19 switched digital high-definition channels.

20 (b) Shall specify the programming and the video service provider
21 may require that the channels regularly display an unobtrusive logo or
22 other suitable identifier of the video service provider, if the local
23 government requires channel capacity pursuant to subdivision (a) of this
24 paragraph.

25 (c) May require all video service providers to incur costs and
26 expenses to provide, maintain and operate facilities and equipment of the
27 video service network, including facilities and equipment for signal
28 carriage, processing, reformatting and interconnection for all of the
29 following:

30 (i) To connect the video service network or cable system, as it may
31 be relocated from time to time, to transmit programming to and from
32 existing locations of public, educational or governmental access
33 facilities and to allow monitoring of access programming at the
34 facilities.

35 (ii) To transmit public, educational and governmental access
36 channels to subscribers with the same prevailing quality, functionality
37 and identification as other channels.

38 (d) May require all video service providers and incumbent cable
39 operators to provide at no initial or recurring charge the basic service
40 tier of video service to one outlet and one receiving device at each
41 building occupied by the local government if the building is not more than
42 two hundred feet from the nearest technically and commercially feasible
43 point of connection on the video service network.

1 2. A local government may retain nonreceiving equipment that it
2 owns without charge for the equipment's use and at the local government's
3 expense, including equipment previously provided by an incumbent cable
4 operator.

5 E. A local law may not impose any obligation on a video service
6 provider under subsection D of this section that is more burdensome than
7 the least burdensome requirement under any local license with a service
8 area within the boundaries of the local government that was in effect on
9 February 1, 2019.

10 F. None of the annual fair market value of any channel capacity
11 provided pursuant to subsection D, paragraph 1, subdivision (a), the
12 annual costs and expenses incurred pursuant to subsection D, paragraph 1,
13 subdivision (c) and the annual fair market value of basic service and line
14 extension provided pursuant to subsection D, paragraph 1, subdivision (d)
15 may be offset against the license fee levied or assessed under this
16 section.

17 G. Notwithstanding subsection A of this section, by a
18 nondiscriminatory local law that imposes and enforces the obligations
19 equally and uniformly on all video service providers operating within the
20 boundaries of a local government, a local government may require that a
21 video service provider bear all of the reasonable costs that are
22 associated with repair and restoration of damage caused to private
23 property or highways by the repair, replacement, installation,
24 construction, maintenance or operation of the video service provider's
25 facilities in the highways and that are imposed on a competitively neutral
26 and nondiscriminatory basis in relation to costs borne by
27 telecommunications corporations under section 9-582, subsection C.

28 H. On application, a local government shall issue to a video
29 service provider or its affiliate a permit to attach allowed Wi-Fi radio
30 equipment to the video service network in the highways within the
31 boundaries of the local government. The permit shall allow installation,
32 operation and maintenance of allowed Wi-Fi radio equipment. A local
33 government may require that all of the allowed Wi-Fi radio equipment at a
34 single location fit within a fifteen-inch cube and be contained entirely
35 within a ground-mounted pedestal or be connected directly to and mounted
36 at the same height as one of the video service provider's aerial
37 horizontal conductors. This subsection does not do any of the following:

38 1. Prohibit a local government from requiring a video service
39 provider to place underground aerial facilities to which allowed Wi-Fi
40 equipment is attached.

41 2. Prohibit the imposition of a tax, rent, fee or charge on revenue
42 from services provided through allowed Wi-Fi radio equipment.

43 3. Affect the authority of a local government to manage the
44 highways within its boundaries or to exercise its police powers, including
45 review and approval of an application before issuing a permit.

1 4. Affect any authority of a political subdivision, including an
2 agricultural improvement district or any other special taxing district,
3 the local government or any other person controlling utility poles in the
4 highways to deny, limit, restrict or determine the terms and conditions
5 for the use of or attachment to the utility poles or attachments to other
6 poles of the political subdivision, local government or other person by a
7 video service provider.

8 I. This section does not prohibit a video service provider from
9 agreeing with a local government to provide in-kind services or goods or
10 make in-kind payments in the service area that are otherwise prohibited by
11 this section if the agreement with the local government is not entered
12 into as a condition of operating in the service area under a uniform video
13 service license issued pursuant to this chapter. The agreement may
14 authorize the video service provider to retain license fees and taxes
15 collected from its subscribers in the amount of any offset to license fees
16 specified in the agreement.

17 J. For the purposes of this section, "allowed Wi-Fi radio
18 equipment" means radio equipment that uses only unlicensed radio spectrum
19 and that enables wireless communication with a communications network for
20 unlicensed services such as Wi-Fi service.

21 Sec. 5. Section 9-1444, Arizona Revised Statutes, is amended to
22 read:

23 9-1444. Ownership of a video service network

24 ~~A.~~ A ~~city or town~~ LOCAL GOVERNMENT may not acquire an ownership
25 interest in a video service network unless the ownership interest is
26 acquired at not less than fair market value.

27 ~~B. Except for the purposes of acting as an intermediary in a~~
28 ~~transfer of a uniform video service license, a county may not own a video~~
29 ~~service network.~~

30 Sec. 6. Section 9-1445, Arizona Revised Statutes, is amended to
31 read:

32 9-1445. Review and audit; bundling discounts; action to
33 recover underpayment or overpayment

34 A. Not more than once every three years, a local government, ~~may~~ on
35 reasonable written notice, MAY audit the business books and records of a
36 video service provider to the extent necessary to ensure payment of
37 license fees pursuant to this chapter. The local government may not audit
38 any period that ends more than three years before the date that the notice
39 of audit is received. Any ~~audits~~ AUDIT of a period of time before
40 issuance of a uniform video service license shall be conducted pursuant to
41 the local laws in effect during the period of time.

42 B. Except as otherwise provided by federal law, if a video service
43 provider offers video service bundled with other services that are not
44 video service for a single discounted price, all of the following apply:

1 1. The method that the video service provider uses to determine
2 gross revenue subject to license fees by allocating the single discounted
3 price among the bundle of video service and nonvideo services shall be
4 reasonable and supported by the video service provider's books and
5 records.

6 2. The local government shall accept as reasonable, for purposes of
7 meeting the video service provider's burden of proof, an allocation based
8 on an objective and verifiable method using the books and records that the
9 video service provider kept in the regular course of business for other
10 purposes, including nontax purposes.

11 3. A video service provider may not use bundled offerings as a
12 means to evade paying license fees.

13 C. The local government and the video service provider shall each
14 pay its own costs and fees relating to each audit performed pursuant to
15 subsection A of this section. If the sum determined to be underpaid
16 exceeds five percent of the total fees that the audit determines should
17 have been paid for the period, the video service provider shall pay the
18 local government's reasonable costs of the audit.

19 D. The rate of interest for both underpayments and overpayments is
20 the federal short-term rate determined pursuant to 26 United States Code
21 section 6621(b), plus three percentage points.

22 E. A person that performs a review and audit under subsection A of
23 this section may not receive compensation that is based, in whole or in
24 part, on either of the following:

- 25 1. Finding a particular result.
26 2. The amount of any underpayment or overpayment of the license fee
27 that is identified because of the review and audit.

28 F. A complaint by a local government for underpayment of a license
29 fee from a video service provider or by a video service provider for
30 overpayment of a license fee to a local government shall be made pursuant
31 to article 5 of this chapter.

32 G. A complaint for a violation of the license fee obligations under
33 this chapter may not be made unless a written demand by a local government
34 for payment of the license fees or a written demand by a video service
35 provider for refund of license fees is made within four months after the
36 local government or video service provider realizes it has been damaged or
37 knows or reasonably should know of the damage caused by the alleged
38 violation.

39 H. A complaint must be filed pursuant to article 5 of this chapter
40 within two years after the written demand is made pursuant to ~~this~~
41 subsection G OF THIS SECTION but not sooner than four months after the
42 written demand.

1 Sec. 7. Section 9-1451, Arizona Revised Statutes, is amended to
2 read:

3 9-1451. Enforcement; office of administrative hearings; fees;
4 fund

5 A. A local government may file a written complaint against a video
6 service provider and a video service provider may file a written complaint
7 against a local government alleging a violation of this chapter or the
8 uniform video service license agreement. Unless otherwise provided in
9 section 9-1445, subsections F, G and H or this section:

10 1. All complaints must be filed with the office of administrative
11 hearings.

12 2. The complainant must serve a copy of the complaint on the party
13 that is the subject of the complaint by personal delivery or certified
14 mail, return receipt requested, or by any other method reasonably
15 calculated to effect actual notice to the local government's last address
16 of record for the party that is the subject of the complaint.

17 3. The party that is the subject of the complaint may file a
18 response to the complaint with the office of administrative hearings
19 within twenty days after service pursuant to paragraph 2 of this
20 subsection. Responses shall be served pursuant to paragraph 2 of this
21 subsection.

22 B. Before filing a complaint pursuant to this section ~~and~~ BOTH of
23 the following apply:

24 1. The complainant must provide notice of the alleged violation of
25 this chapter to the party that is the subject of the complaint.

26 2. The party that is the subject of the complaint must have a
27 period of not less than twenty days after the date it receives the notice
28 to resolve the alleged violation.

29 C. **SUBSECTION B OF THIS SECTION DOES NOT APPLY TO A COMPLAINT MADE**
30 **IN A WRITTEN DEMAND PURSUANT TO SECTION 9-1445, SUBSECTION G.**

31 ~~C.~~ D. A hearing before the office of administrative hearings shall
32 be held if a complaint that complies with this section is filed with the
33 office of administrative hearings. Unless other deadlines are established
34 for a particular complaint, all of the following apply:

35 1. The hearing shall be held within two months after the date that
36 the complaint is filed and service is completed pursuant to subsection A
37 of this section.

38 2. The date scheduled for the hearing may be advanced or delayed on
39 the agreement of the parties or on a showing of good cause.

40 ~~D.~~ E. The office of administrative hearings shall prepare and
41 serve a notice of hearing on all parties at least one month before the
42 hearing that states the time and place of the hearing.

43 ~~E.~~ F. A prehearing conference may be held pursuant to section
44 41-1092.05.

1 ~~F.~~ G. Unless it conflicts with the requirements of this section,
2 the hearing shall be conducted pursuant to section 41-1092.07.

3 ~~G.~~ H. The complainant has the burden of persuasion at a hearing
4 under this section.

5 ~~H.~~ I. The decision of the administrative law judge is the final
6 administrative decision with respect to the complaint. The office of
7 administrative hearings shall serve a copy of the administrative law
8 judge's decision on all parties. The final administrative decision may be
9 appealed to the superior court pursuant to title 12, chapter 7, article 6.
10 ~~Notwithstanding section 12-910,~~ The superior court proceeding shall be a
11 trial de novo.

12 ~~I.~~ J. A party may move for rehearing pursuant to section
13 41-1092.09 and the office of administrative hearings shall rule on the
14 motion. Moving for rehearing or review is not necessary for the party to
15 seek judicial review of the decision of the administrative law judge under
16 subsection ~~H~~ I of this section.

17 ~~J.~~ K. Service is complete on personal service or five days after
18 the date that the office of administrative hearings mails the final
19 administrative decision to each party's last known address of record with
20 the local government.

21 ~~K.~~ L. The office of administrative hearings shall adopt rules
22 pursuant to title 41, chapter 6 to administer hearings under this chapter
23 AND TITLE 11, CHAPTER 14. THE RULES SHALL APPLY UNIFORMLY TO HEARINGS
24 INVOLVING LOCAL GOVERNMENTS AND COUNTIES.

25 ~~L.~~ M. The office of administrative hearings shall establish,
26 administer and collect fees in an amount to be determined by the director
27 of the office of administrative hearings. The director shall deposit,
28 pursuant to sections 35-146 and 35-147, all monies in the video service
29 provider complaint fund established by subsection ~~M~~ N of this section.

30 ~~M.~~ N. The video service provider complaint fund is established
31 consisting of monies collected pursuant to subsection ~~L~~ M of this section
32 AND SECTION 11-1951, SUBSECTION M. The office of administrative hearings
33 shall administer the fund. Monies in the fund are continuously
34 appropriated. The office of administrative hearings shall use the monies
35 in the fund for the purpose of administering the duties specified in this
36 article AND TITLE 11, CHAPTER 14, ARTICLE 5.

37 Sec. 8. Title 11, Arizona Revised Statutes, is amended by adding
38 chapter 14, to read:

39 CHAPTER 14

40 VIDEO SERVICE

41 ARTICLE 1. GENERAL PROVISIONS

42 11-1901. Definitions

43 A. IN THIS CHAPTER, UNLESS THE CONTEXT OTHERWISE REQUIRES:

1 1. "AFFILIATE" MEANS A PERSON THAT DIRECTLY OR INDIRECTLY, THROUGH
2 ONE OR MORE INTERMEDIARIES, CONTROLS, IS CONTROLLED BY OR IS UNDER COMMON
3 CONTROL WITH A VIDEO SERVICE PROVIDER.

4 2. "AGREEMENT" MEANS ANY AGREEMENT OR CONTRACT.

5 3. "BOUNDARIES OF A COUNTY" OR "BOUNDARIES" MEANS ALL OF THE AREA
6 OF THE COUNTY THAT IS NOT WITHIN THE CORPORATE LIMITS OF ANY CITY OR TOWN,
7 INCLUDING UNINCORPORATED TERRITORY THAT IS SURROUNDED ON ALL SIDES BY A
8 COMBINATION OF ONE OR MORE CITIES, TOWNS OR INDIAN RESERVATIONS.

9 4. "CABLE OPERATOR" HAS THE SAME MEANING PRESCRIBED IN 47 UNITED
10 STATES CODE SECTION 522.

11 5. "CABLE SERVICE" HAS THE SAME MEANING PRESCRIBED IN 47 UNITED
12 STATES CODE SECTION 522.

13 6. "CABLE SYSTEM" HAS THE SAME MEANING PRESCRIBED IN 47 UNITED
14 STATES CODE SECTION 522.

15 7. "COMMERCIAL MOBILE SERVICE PROVIDER" MEANS A PERSON THAT
16 PROVIDES COMMERCIAL MOBILE SERVICE AS DEFINED IN 47 UNITED STATES CODE
17 SECTION 332(d) OR COMMERCIAL MOBILE RADIO SERVICE AS DESCRIBED IN 47 CODE
18 OF FEDERAL REGULATIONS SECTION 20.3.

19 8. "DAY" MEANS A CALENDAR DAY, EXCEPT A SATURDAY OR SUNDAY OR A
20 HOLIDAY PRESCRIBED IN SECTION 1-301.

21 9. "GROSS REVENUE":

22 (a) MEANS ALL CASH, CREDITS, PROPERTY OF ANY KIND OR NATURE OR
23 OTHER CONSIDERATION THAT IS RECEIVED DIRECTLY OR INDIRECTLY BY A VIDEO
24 SERVICE PROVIDER, ITS AFFILIATES, OR ANY PERSON, FIRM OR CORPORATION IN
25 WHICH THE VIDEO SERVICE PROVIDER HAS A FINANCIAL INTEREST OR THAT HAS A
26 FINANCIAL INTEREST IN THE VIDEO SERVICE PROVIDER AND THAT IS DERIVED FROM
27 THE VIDEO SERVICE PROVIDER'S OPERATION OF ITS VIDEO SERVICE NETWORK TO
28 PROVIDE VIDEO SERVICE IN THE SERVICE AREA.

29 (b) INCLUDES ALL REVENUE FROM CHARGES FOR VIDEO SERVICE TO
30 SUBSCRIBERS AND ALL CHARGES FOR INSTALLATION, REMOVAL, CONNECTION OR
31 REINSTATEMENT OF EQUIPMENT NECESSARY FOR A SUBSCRIBER TO RECEIVE VIDEO
32 SERVICE AND ANY OTHER RECEIPTS FROM SUBSCRIBERS DERIVED FROM THE VIDEO
33 SERVICE PROVIDER'S OPERATION OF THE VIDEO SERVICE NETWORK TO PROVIDE VIDEO
34 SERVICE, INCLUDING RECEIPTS FROM FORFEITED DEPOSITS, SALE OR RENTAL OF
35 EQUIPMENT TO PROVIDE VIDEO SERVICE, LATE CHARGES, INTEREST AND SALE OF
36 PROGRAM GUIDES.

37 (c) DOES NOT INCLUDE:

38 (i) ANY REVENUE NOT RECEIVED, EVEN IF BILLED, SUCH AS BAD DEBT NET
39 OF ANY RECOVERIES OF BAD DEBT OR ANY REFUNDS, REBATES, CREDITS, ALLOWANCES
40 OR DISCOUNTS TO SUBSCRIBERS TO THE EXTENT THAT THE REFUND, REBATE, CREDIT,
41 ALLOWANCE OR DISCOUNT IS ATTRIBUTED TO VIDEO SERVICE.

42 (ii) REVENUE FROM COMMERCIAL ADVERTISING ON THE VIDEO SERVICE
43 NETWORK, THE USE OR LEASE OF STUDIO FACILITIES OF THE VIDEO SERVICE
44 NETWORK, INTERNET ACCESS SERVICE, THE USE OR LEASE OF ITS FACILITIES
45 LOCATED IN THE HIGHWAYS, THE USE OR LEASE OF LEASED ACCESS CHANNELS OR

1 BANDWIDTH, THE USE OR LEASE OF TOWERS, THE PRODUCTION OF VIDEO PROGRAMMING
2 BY THE VIDEO SERVICE PROVIDER, THE SALE, EXCHANGE, USE OR CABLECAST OF ANY
3 PROGRAMMING BY THE VIDEO SERVICE PROVIDER IN THE SERVICE AREA, SALES TO
4 THE VIDEO SERVICE PROVIDER'S SUBSCRIBERS BY PROGRAMMERS OF HOME SHOPPING
5 SERVICES, REIMBURSEMENTS PAID BY PROGRAMMERS FOR LAUNCH FEES OR MARKETING
6 EXPENSES, LICENSE FEES, TAXES OR OTHER FEES OR CHARGES THAT THE VIDEO
7 SERVICE PROVIDER COLLECTS AND PAYS TO ANY GOVERNMENTAL AUTHORITY, ANY
8 INCREASE IN THE VALUE OF ANY STOCK, SECURITY OR ASSET OR ANY DIVIDENDS OR
9 OTHER DISTRIBUTIONS MADE FROM ANY STOCK OR SECURITIES.

10 10. "HIGHWAY" MEANS ALL ROADS, STREETS AND ALLEYS AND OTHER
11 DEDICATED PUBLIC RIGHTS-OF-WAY THAT ARE OPERATED AND MAINTAINED BY THE
12 COUNTY.

13 11. "HOLDER" MEANS A VIDEO SERVICE PROVIDER THAT HAS BEEN ISSUED A
14 UNIFORM VIDEO SERVICE LICENSE PURSUANT TO THIS CHAPTER.

15 12. "HOLDOVER CABLE OPERATOR" MEANS AN INCUMBENT CABLE OPERATOR
16 THAT ELECTS UNDER SECTIONS 11-1912 AND 11-1913 TO CONTINUE TO OPERATE
17 WITHIN ITS SERVICE AREA PURSUANT TO ITS LOCAL LICENSE.

18 13. "INCUMBENT CABLE OPERATOR" MEANS A CABLE OPERATOR OR OTHER
19 VIDEO SERVICE PROVIDER THAT ON DECEMBER 31, 2019 IS PROVIDING VIDEO
20 SERVICE IN THIS STATE PURSUANT TO A LOCAL LICENSE.

21 14. "INFORMATION SERVICE" HAS THE SAME MEANING PRESCRIBED IN 47
22 UNITED STATES CODE SECTION 153.

23 15. "INTERACTIVE COMPUTER SERVICE" HAS THE SAME MEANING PRESCRIBED
24 IN 47 UNITED STATES CODE SECTION 230(f).

25 16. "LICENSE" MEANS A FRANCHISE AS DEFINED IN 47 UNITED STATES CODE
26 SECTION 522.

27 17. "LICENSE FEE" MEANS A LICENSE FEE IMPOSED BY A COUNTY ON A
28 VIDEO SERVICE PROVIDER FOR USING THE HIGHWAYS TO PROVIDE AND FOR THE
29 PRIVILEGE OF PROVIDING VIDEO SERVICE.

30 18. "LOCAL LAW" MEANS ANY CODE, ORDINANCE, RESOLUTION, REGULATION
31 OR OTHER LAW OF A COUNTY.

32 19. "LOCAL LICENSE" MEANS ANY LICENSE, AGREEMENT, PERMIT OR SIMILAR
33 AUTHORIZATION THAT MEETS ALL OF THE FOLLOWING:

34 (a) ALLOWS A PERSON TO CONSTRUCT OR OPERATE A VIDEO SERVICE NETWORK
35 WITHIN THE BOUNDARIES OF A COUNTY.

36 (b) IS ISSUED, GRANTED, APPROVED, EXTENDED OR RENEWED BY THE COUNTY
37 BEFORE JANUARY 1, 2020 PURSUANT TO THE AUTHORITY OF ANY FEDERAL, STATE OR
38 LOCAL LAW IN EFFECT AT THE TIME OF THE ISSUANCE, GRANT, APPROVAL,
39 EXTENSION OR RENEWAL.

40 (c) IS EFFECTIVE UNDER FEDERAL, STATE OR LOCAL LAW ON DECEMBER 31,
41 2019 FOR THE PERSON TO CONTINUE TO CONSTRUCT OR OPERATE A VIDEO SERVICE
42 NETWORK WITHIN THE BOUNDARIES OF A COUNTY.

43 20. "MULTICHANNEL VIDEO PROGRAMMING DISTRIBUTOR" HAS THE SAME
44 MEANING PRESCRIBED IN 47 UNITED STATES CODE SECTION 522.

1 21. "SERVICE AREA" MEANS THAT PART OF THE BOUNDARIES OF A COUNTY
2 WITHIN WHICH A VIDEO SERVICE PROVIDER IS AUTHORIZED TO PROVIDE VIDEO
3 SERVICE PURSUANT TO A UNIFORM VIDEO SERVICE LICENSE OR A LOCAL LICENSE.

4 22. "SUBSCRIBER" MEANS ANY PERSON IN THIS STATE THAT PURCHASES
5 VIDEO SERVICE. SUBSCRIBER DOES NOT INCLUDE ANY PERSON THAT PURCHASES
6 VIDEO SERVICE FOR RESALE AND THAT, ON RESALE, IS REQUIRED TO PAY A LICENSE
7 FEE PURSUANT TO THIS CHAPTER OR THE TERMS OF A LOCAL LICENSE.

8 23. "TELECOMMUNICATIONS":

9 (a) MEANS THE TRANSMISSION, BETWEEN OR AMONG POINTS SPECIFIED BY
10 THE USER, OF INFORMATION OF THE USER'S CHOOSING, WITHOUT CHANGE IN THE
11 FORM OR CONTENT OF THE INFORMATION SENT AND RECEIVED, REGARDLESS OF THE
12 FACILITIES, EQUIPMENT OR TECHNOLOGY USED.

13 (b) DOES NOT INCLUDE COMMERCIAL MOBILE RADIO SERVICE, PAY PHONE
14 SERVICE, INTERSTATE SERVICE OR CABLE SERVICE.

15 24. "TELECOMMUNICATIONS PROVIDER" MEANS A PERSON THAT IS REQUIRED
16 TO OBTAIN FROM THE CORPORATION COMMISSION A CERTIFICATE OF PUBLIC
17 CONVENIENCE AND NECESSITY TO PROVIDE TELECOMMUNICATIONS SERVICE.

18 25. "TELECOMMUNICATIONS SERVICE" MEANS THE OFFERING OF
19 TELECOMMUNICATIONS FOR A FEE DIRECTLY TO THE PUBLIC, OR TO SUCH USERS AS
20 TO BE EFFECTIVELY AVAILABLE DIRECTLY TO THE PUBLIC, REGARDLESS OF THE
21 EQUIPMENT, FACILITIES OR TECHNOLOGY USED.

22 26. "UNIFORM VIDEO SERVICE LICENSE" MEANS A LICENSE THAT IS ISSUED
23 BY A COUNTY IN THE FORM OF UNIFORM VIDEO SERVICE LICENSE AGREEMENT AS
24 ADOPTED PURSUANT TO SECTION 11-1911.

25 27. "VIDEO SERVICE":

26 (a) MEANS THE PROVISION OF MULTICHANNEL VIDEO PROGRAMMING GENERALLY
27 CONSIDERED COMPARABLE TO VIDEO PROGRAMMING DELIVERED BY A TELEVISION
28 BROADCAST STATION, VIDEO SERVICE OR OTHER DIGITAL TELEVISION SERVICE,
29 WHETHER PROVIDED AS PART OF A TIER, ON DEMAND OR ON A PER-CHANNEL BASIS,
30 WITHOUT REGARD TO THE TECHNOLOGY USED TO DELIVER THE VIDEO SERVICE,
31 INCLUDING INTERNET PROTOCOL TECHNOLOGY OR ANY SUCCESSOR TECHNOLOGY.

32 (b) INCLUDES CABLE SERVICE.

33 (c) DOES NOT INCLUDE ANY OF THE FOLLOWING:

34 (i) VIDEO PROGRAMMING PROVIDED SOLELY AS PART OF, AND THROUGH, A
35 SERVICE THAT ENABLES USERS TO ACCESS CONTENT, INFORMATION, E-MAIL,
36 MESSAGING OR OTHER SERVICES THAT ARE OFFERED VIA THE PUBLIC INTERNET.

37 (ii) DIRECT BROADCAST SATELLITE SERVICE.

38 (iii) WIRELESS MULTICHANNEL VIDEO PROGRAMMING THAT IS PROVIDED BY A
39 COMMERCIAL MOBILE SERVICE PROVIDER.

40 28. "VIDEO SERVICE NETWORK":

41 (a) MEANS A WIRELINE NETWORK, OR ANY COMPONENT OF A WIRELINE
42 NETWORK, THAT IS LOCATED IN THIS STATE, CONSTRUCTED IN WHOLE OR IN PART
43 IN, ON, UNDER OR OVER ANY HIGHWAY AND USED TO PROVIDE VIDEO SERVICE.

44 (b) INCLUDES A CABLE SYSTEM.

1 29. "VIDEO SERVICE PROVIDER":
2 (a) MEANS ANY PERSON THAT PROVIDES OR OFFERS TO PROVIDE VIDEO
3 SERVICE OVER A VIDEO SERVICE NETWORK TO SUBSCRIBERS IN THIS STATE.
4 (b) INCLUDES AN INCUMBENT CABLE OPERATOR THAT ELECTED PURSUANT TO
5 SECTIONS 11-1912 AND 11-1913 TO TERMINATE ITS LOCAL LICENSE AND A
6 MULTICHANNEL VIDEO PROGRAMMING DISTRIBUTOR.
7 (c) DOES NOT INCLUDE A HOLDOVER CABLE OPERATOR.
8 11-1902. State preemption; uniform regulation and licensing
9 A. THE LICENSING OF VIDEO SERVICE PROVIDERS AND THE REGULATION AND
10 USE OF VIDEO SERVICE ARE MATTERS OF STATEWIDE CONCERN. EXCEPT AS PROVIDED
11 IN THIS CHAPTER, THE LICENSING OF VIDEO SERVICE PROVIDERS AND THE
12 REGULATION AND USE OF VIDEO SERVICE ARE NOT SUBJECT TO FURTHER REGULATION
13 BY A COUNTY. THE REGULATION OF VIDEO SERVICE PURSUANT TO THIS CHAPTER,
14 INCLUDING APPLICATION TO THE LOCAL LICENSES OF INCUMBENT CABLE OPERATORS,
15 IS REASONABLE AND NECESSARY TO PROMOTE ALL OF THE FOLLOWING:
16 1. PROVISION OF COMPETITIVE VIDEO, TELECOMMUNICATIONS AND
17 INFORMATION SERVICE THROUGHOUT THIS STATE.
18 2. MORE UNIFORM REGULATION OF COMPETITIVE VIDEO SERVICE THROUGHOUT
19 THIS STATE.
20 3. STREAMLINED LICENSING BY COUNTIES AND MORE UNIFORM TERMS AND
21 CONDITIONS FOR VIDEO SERVICE PROVIDERS THAT USE HIGHWAYS TO PROVIDE VIDEO
22 AND OTHER SERVICES OVER VIDEO SERVICE NETWORKS.
23 4. CONTINUED MANAGEMENT BY COUNTIES OF USE OF THEIR HIGHWAYS WITH
24 REASONABLE BURDENS ON CONSTRUCTION AND MAINTENANCE ACROSS BOUNDARIES FOR
25 VIDEO SERVICE PROVIDERS TO USE HIGHWAYS TO PROVIDE VIDEO AND OTHER
26 SERVICES OVER VIDEO SERVICE NETWORKS.
27 5. CONTINUED LEVYING OF LICENSE FEES BY COUNTIES ON SUBSCRIBER
28 SERVICE REVENUES DERIVED FROM OPERATING VIDEO SERVICE NETWORKS TO PROVIDE
29 VIDEO SERVICE.
30 6. SUPPORT FOR FEDERAL SUBSCRIBER SERVICE STANDARDS.
31 B. TO THE FULLEST EXTENT ALLOWED BY FEDERAL LAW, THIS CHAPTER
32 OCCUPIES THE ENTIRE FIELD OF LICENSING AND REGULATION OF VIDEO SERVICE.
33 C. EXCEPT AS OTHERWISE PROVIDED IN THIS CHAPTER, FROM AND AFTER
34 DECEMBER 31, 2019 THIS CHAPTER PREEMPTS AND LIMITS THE ABILITY OF A COUNTY
35 TO REGULATE OR ENFORCE ALL OF THE FOLLOWING:
36 1. THE APPLICATION OF TITLE 9, CHAPTER 5, ARTICLE 1.1 TO VIDEO
37 SERVICE PROVIDERS.
38 2. ANY LOCAL LAW AND ANY AGREEMENT WITH A COUNTY THAT DOES ANY OF
39 THE FOLLOWING:
40 (a) REQUIRES A PERSON OTHER THAN A HOLDOVER CABLE OPERATOR TO
41 OBTAIN OR HOLD FROM A COUNTY ANY LICENSE, PERMIT OR SIMILAR AUTHORIZATION
42 THAT IS A PREREQUISITE TO PROVIDING VIDEO SERVICE OR TO CONSTRUCTING,
43 MAINTAINING OR USING THE HIGHWAYS TO OPERATE A VIDEO SERVICE NETWORK IN
44 THE HIGHWAYS WITHIN ITS BOUNDARIES.

1 (b) REGULATES THE PROVISION OF VIDEO SERVICE OR THE CONSTRUCTION OR
2 OPERATION OF A VIDEO SERVICE NETWORK IF THE LOCAL LAW DOES NOT CONFORM TO
3 THIS CHAPTER.

4 (c) IMPOSES ON A VIDEO SERVICE PROVIDER ANY REQUIREMENT THAT IS
5 RELATED TO INFRASTRUCTURE, FACILITIES OR DEPLOYMENT OF EQUIPMENT THAT DOES
6 NOT CONFORM TO THIS CHAPTER, INCLUDING OFFICE LOCATION, INSTITUTIONAL
7 NETWORK, BUILD-OUT, LINE EXTENSION, INVESTMENT OR OTHER OPERATIONAL
8 REQUIREMENTS THAT ARE NOT DIRECTLY RELATED TO THE COUNTY'S MANAGEMENT OF
9 DEVELOPMENT, USE AND OCCUPANCY OF THE HIGHWAYS.

10 (d) REQUIRES A VIDEO SERVICE PROVIDER TO OBTAIN A LICENSE OR OTHER
11 AUTHORIZATION FROM THE COUNTY TO PROVIDE TELECOMMUNICATIONS SERVICE,
12 INFORMATION SERVICE, INTERACTIVE COMPUTER SERVICE OR OTHER SERVICE IF THE
13 VIDEO SERVICE PROVIDER USES ITS VIDEO SERVICE NETWORK WITHIN THE
14 BOUNDARIES OF THE COUNTY TO PROVIDE THE SERVICE.

15 (e) REQUIRES A VIDEO SERVICE PROVIDER TO PAY TO LOCATE IN DUCTS OR
16 CONDUITS OR ON POLES OWNED BY THE COUNTY IF THE COUNTY REQUIRES
17 INSTALLATION IN THE DUCTS OR CONDUITS OR ON THE POLES.

18 11-1903. Limited application

19 THIS CHAPTER DOES NOT:

20 1. PREVENT A TELECOMMUNICATIONS PROVIDER FROM EXERCISING ANY RIGHTS
21 OR AUTHORITY THAT THE TELECOMMUNICATIONS PROVIDER HAS AS A PUBLIC UTILITY
22 UNDER FEDERAL OR STATE LAW.

23 2. AFFECT ANY AUTHORITY OF A COUNTY, AN AGRICULTURAL IMPROVEMENT
24 DISTRICT, ANY SPECIAL TAXING DISTRICT OR ANY OTHER PERSON THAT CONTROLS
25 UTILITY POLES ON THE HIGHWAYS TO DENY, LIMIT, RESTRICT OR DETERMINE THE
26 RATES, TERMS AND CONDITIONS FOR THE USE OF OR ATTACHMENT BY A VIDEO
27 SERVICE PROVIDER TO UTILITY OR OTHER POLES OWNED BY THE COUNTY OR OTHER
28 PERSON. FOR THE PURPOSES OF THIS PARAGRAPH, "AUTHORITY OF A COUNTY"
29 INCLUDES POLICE POWERS.

30 3. VEST IN THE CORPORATION COMMISSION ANY AUTHORITY OR JURISDICTION
31 OVER VIDEO SERVICE, VIDEO SERVICE PROVIDERS OR VIDEO SERVICE NETWORKS OR
32 OVER THE RATES, TERMS AND CONDITIONS OF POLE ATTACHMENTS UNDER 47 UNITED
33 STATES CODE SECTION 224.

34 4. AFFECT OR PREEMPT ANY GENERALLY APPLICABLE LOCAL LAWS, INCLUDING
35 A COUNTY'S POLICE POWER, TO MANAGE USE AND OCCUPANCY OF THE HIGHWAYS
36 WITHIN THE COUNTY'S BOUNDARIES OR TO EXERCISE THE COUNTY'S POLICE POWERS
37 IF THE COUNTY APPLIES THE LOCAL LAWS AND EXERCISE OF POLICE POWERS TO ALL
38 USERS OF THE HIGHWAYS IN A NONDISCRIMINATORY MANNER.

39 ARTICLE 2. LOCAL LICENSES

40 11-1911. Counties; uniform video service license agreement;
41 forms; provisions

42 A. FROM AND AFTER DECEMBER 31, 2019, A COUNTY HAS THE EXCLUSIVE
43 AUTHORITY TO ISSUE A UNIFORM VIDEO SERVICE LICENSE TO A PERSON TO PROVIDE
44 VIDEO SERVICE AND TO CONSTRUCT AND OPERATE A VIDEO SERVICE NETWORK IN ANY
45 SERVICE AREA WITHIN ITS BOUNDARIES.

1 B. NOT LATER THAN THE EFFECTIVE DATE OF THIS SECTION, EACH COUNTY
2 SHALL ADOPT A STANDARD FORM OF UNIFORM VIDEO SERVICE LICENSE AGREEMENT FOR
3 VIDEO SERVICE PROVIDERS TO BE USED BY THE COUNTY AND A STANDARD FORM OF
4 APPLICATION AND AFFIDAVIT AS DESCRIBED IN SECTION 11-1914. A COUNTY SHALL
5 PRESCRIBE OTHER FORMS ONLY AS NECESSARY TO IMPLEMENT THIS CHAPTER.

6 C. THE UNIFORM VIDEO SERVICE LICENSE AGREEMENT ADOPTED UNDER
7 SUBSECTION B OF THIS SECTION MUST INCLUDE ALL OF THE FOLLOWING PROVISIONS
8 IN SUBSTANTIALLY THE FOLLOWING FORM AND MAY NOT INCLUDE ANY OTHER
9 PROVISIONS:

10 1. THE NAME OF THE VIDEO SERVICE PROVIDER, ITS TYPE OF ENTITY AND
11 ITS JURISDICTION OF FORMATION.

12 2. THE ADDRESS AND TELEPHONE NUMBER OF THE VIDEO SERVICE PROVIDER'S
13 PRINCIPAL PLACE OF BUSINESS.

14 3. THE NAME AND ADDRESS OF THE VIDEO SERVICE PROVIDER'S PRINCIPAL
15 EXECUTIVE OFFICERS OR GENERAL PARTNERS AND ANY PERSONS AUTHORIZED TO
16 REPRESENT THE VIDEO SERVICE PROVIDER BEFORE THE COUNTY.

17 4. IF THE VIDEO SERVICE PROVIDER IS NOT AN INCUMBENT CABLE
18 OPERATOR, THE DATE ON WHICH THE PROVIDER EXPECTS TO PROVIDE VIDEO SERVICE
19 IN THE AREA IDENTIFIED UNDER PARAGRAPH 5 OF THIS SUBSECTION.

20 5. AN EXACT DESCRIPTION OF THE SERVICE AREA TO BE SERVED, AS
21 IDENTIFIED BY A GEOGRAPHIC INFORMATION SYSTEM DIGITAL BOUNDARY THAT MEETS
22 OR EXCEEDS NATIONAL MAP ACCURACY STANDARDS.

23 6. A REQUIREMENT THAT THE VIDEO SERVICE PROVIDER PAY THE LICENSE
24 FEES REQUIRED UNDER THIS CHAPTER AND ALL OTHER LAWFUL FEES AND CHARGES
25 IMPOSED BY THE COUNTY.

26 7. A REQUIREMENT THAT THE VIDEO SERVICE PROVIDER FILE IN A TIMELY
27 MANNER WITH THE FEDERAL COMMUNICATIONS COMMISSION ALL FORMS REQUIRED BY
28 THAT AGENCY BEFORE OFFERING VIDEO SERVICE IN THE SERVICE AREA, INCLUDING
29 THE FORMS REQUIRED BY 47 CODE OF FEDERAL REGULATIONS SECTION 76.1801.

30 8. A REQUIREMENT THAT THE VIDEO SERVICE PROVIDER AGREES TO COMPLY
31 WITH AND BE SUBJECT TO ALL VALID AND ENFORCEABLE FEDERAL AND STATE LAWS.

32 9. A REQUIREMENT THAT THE VIDEO SERVICE PROVIDER AGREES TO COMPLY
33 WITH ALL GENERALLY APPLICABLE, NONDISCRIMINATORY LOCAL LAWS, INCLUDING
34 HIGHWAY USE, MAPPING, INSURANCE, PERFORMANCE BONDS, SECURITY FUND,
35 INDEMNIFICATION OR SIMILAR REQUIREMENTS THAT APPLY TO THE USE AND
36 OCCUPATION OF ANY HIGHWAY AND THAT CONFORM TO THIS CHAPTER.

37 10. A REQUIREMENT THAT THE VIDEO SERVICE PROVIDER COMPLY WITH THE
38 PUBLIC, EDUCATION AND GOVERNMENT PROGRAMMING REQUIREMENTS OF THIS CHAPTER.

39 11. A REQUIREMENT THAT THE VIDEO SERVICE PROVIDER COMPLY WITH ALL
40 CUSTOMER SERVICE RULES OF THE FEDERAL COMMUNICATIONS COMMISSION UNDER 47
41 CODE OF FEDERAL REGULATIONS SECTION 76.309(c) APPLICABLE TO CABLE
42 OPERATORS.

43 12. A REQUIREMENT THAT THE VIDEO SERVICE PROVIDER COMPLY WITH THE
44 CONSUMER PRIVACY REQUIREMENTS OF 47 UNITED STATES CODE SECTION 551
45 APPLICABLE TO CABLE OPERATORS.

1 13. A GRANT OF AUTHORITY BY THE COUNTY TO PROVIDE VIDEO SERVICE IN
2 THE SERVICE AREA AS DESCRIBED UNDER PARAGRAPH 5 OF THIS SUBSECTION.

3 14. A GRANT OF AUTHORITY BY THE COUNTY TO USE AND OCCUPY THE
4 HIGHWAYS IN THE DELIVERY OF THE VIDEO SERVICE, SUBJECT TO THE LAWS OF THIS
5 STATE AND THE POLICE POWERS OF THE COUNTY.

6 15. THE TERM OF THE UNIFORM VIDEO SERVICE LICENSE.

7 16. A REQUIREMENT THAT THE PARTIES TO THE AGREEMENT ARE SUBJECT TO
8 AND MUST COMPLY WITH THIS CHAPTER.

9 D. EXCEPT AS OTHERWISE PROVIDED IN THIS CHAPTER, FROM AND AFTER
10 DECEMBER 31, 2019 A PERSON MAY NOT ACT AS A VIDEO SERVICE PROVIDER OR
11 CONSTRUCT OR OPERATE A VIDEO SERVICE NETWORK WITHIN THE BOUNDARIES OF A
12 COUNTY WITHOUT FIRST HAVING BEEN ISSUED AND CONTINUING TO HOLD A UNIFORM
13 VIDEO SERVICE LICENSE WITH A SERVICE AREA ENCOMPASSING THE BOUNDARIES.

14 E. A LOCAL LICENSE SHALL REMAIN ENFORCEABLE IN ACCORDANCE WITH ITS
15 TERMS UNTIL TERMINATED UNDER SECTION 11-1912, SUBSECTION B.

16 11-1912. Incumbent cable operator; election on local license;
17 procedure to obtain uniform video service license
18 and terminate local license

19 A. FROM AND AFTER DECEMBER 31, 2019, AN INCUMBENT CABLE OPERATOR
20 MAY ELECT TO DO EITHER OF THE FOLLOWING:

21 1. CONTINUE TO OPERATE WITHIN A SERVICE AREA AS DEFINED IN THE
22 LOCAL LICENSE PURSUANT TO SECTION 11-1913.

23 2. TERMINATE THE INCUMBENT CABLE OPERATOR'S LOCAL LICENSE FOR A
24 SERVICE AREA BY APPLYING FOR AND OBTAINING A UNIFORM VIDEO SERVICE LICENSE
25 PURSUANT TO THIS ARTICLE.

26 B. ON OR BEFORE JULY 1, 2020, TO ELECT TO TERMINATE A LOCAL LICENSE
27 UNDER SUBSECTION A OF THIS SECTION IN THE SAME MANNER AS ANY OTHER VIDEO
28 SERVICE PROVIDER, AN INCUMBENT CABLE OPERATOR SHALL APPLY FOR A UNIFORM
29 VIDEO SERVICE LICENSE THAT INCLUDES ONLY THE SERVICE AREA THAT IS DEFINED
30 IN THE LOCAL LICENSE. IF AN INCUMBENT CABLE OPERATOR OBTAINS A UNIFORM
31 VIDEO SERVICE LICENSE FOR THE SERVICE AREA, BOTH OF THE FOLLOWING APPLY:

32 1. THE APPLICANT'S LOCAL LICENSE IS TERMINATED AS TO THE SERVICE
33 AREA BY OPERATION OF LAW FROM AND AFTER THE DATE THE COUNTY ISSUES THE
34 UNIFORM VIDEO SERVICE LICENSE.

35 2. THE INCUMBENT CABLE OPERATOR SHALL OPERATE WITHIN THE SERVICE
36 AREA DEFINED IN THE LOCAL LICENSE UNLESS THE INCUMBENT CABLE OPERATOR
37 ELECTS UNDER SECTION 11-1914, SUBSECTION C TO APPLY FOR A UNIFORM VIDEO
38 SERVICE LICENSE FOR A SERVICE AREA THAT CONSISTS OF THE BOUNDARIES OF THE
39 COUNTY.

40 11-1913. Incumbent cable operator; procedure to continue
41 operating under local license

42 A. IF AN INCUMBENT CABLE OPERATOR DOES NOT TIMELY ELECT TO
43 TERMINATE A LOCAL LICENSE FOR A SERVICE AREA PURSUANT TO SECTION 11-1912,
44 SUBSECTION B, THE PERSON SHALL CONTINUE TO OPERATE THE CABLE SYSTEM AS A
45 HOLDOVER CABLE OPERATOR WITHIN THE SERVICE AREA DEFINED IN THE LOCAL

1 LICENSE AND SHALL COMPLY WITH THE LOCAL LICENSE FOR AS LONG AS IT REMAINS
2 IN EFFECT FOR THE SERVICE AREA. THE LOCAL LICENSE IS NOT EFFECTIVE FOR
3 THE SERVICE AREA FROM AND AFTER THE DATE THE LOCAL LICENSE EXPIRES BY ITS
4 TERMS. THE COUNTY MAY NOT UNILATERALLY RENEW OR EXTEND THE TERM OF THE
5 LOCAL LICENSE FOR THE SERVICE AREA. THE COUNTY AND THE HOLDOVER CABLE
6 OPERATOR SHALL COMPLY WITH ALL OF THE FOLLOWING, WHICH SHALL CONTINUE TO
7 APPLY TO THE LOCAL LICENSE:

- 8 1. TITLE 9, CHAPTER 5, ARTICLE 1.1.
- 9 2. SECTION 9-584.
- 10 3. TITLE 9, CHAPTER 5, ARTICLE 8.
- 11 4. CHAPTER 13, ARTICLE 1 OF THIS TITLE.

12 B. TO OPERATE WITHIN A SERVICE AREA FROM AND AFTER THE DATE THE
13 LOCAL LICENSE EXPIRES, THE HOLDOVER CABLE OPERATOR MUST APPLY FOR AND
14 OBTAIN A UNIFORM VIDEO SERVICE LICENSE IN THE SAME MANNER AS ANY OTHER
15 VIDEO SERVICE PROVIDER.

16 C. IF A HOLDOVER CABLE OPERATOR IS ISSUED A UNIFORM VIDEO SERVICE
17 LICENSE WITH A SERVICE AREA THAT INCLUDES THE SERVICE AREA DEFINED UNDER
18 THE LOCAL LICENSE WHILE OPERATING PURSUANT TO THE LOCAL LICENSE UNDER
19 SUBSECTION A OF THIS SECTION, THE UNIFORM VIDEO SERVICE LICENSE DOES NOT
20 BECOME EFFECTIVE UNTIL THE LOCAL LICENSE EXPIRES.

21 D. A HOLDOVER CABLE OPERATOR THAT ELECTS TO APPLY FOR A UNIFORM
22 VIDEO SERVICE LICENSE SHALL DO SO AT LEAST ONE MONTH BEFORE THE LOCAL
23 LICENSE EXPIRES.

24 11-1914. Uniform video service license; application; fees

25 A. TO OBTAIN A UNIFORM VIDEO SERVICE LICENSE, A PERSON SHALL FILE
26 WITH THE CLERK OF THE COUNTY AN APPLICATION AND AFFIDAVIT THAT ARE SIGNED
27 BY ONE OF THE PRINCIPAL EXECUTIVE OFFICERS OR GENERAL PARTNERS OF THE
28 APPLICANT AND THAT COMPLY WITH THIS SECTION.

29 B. THE APPLICATION AND AFFIDAVIT SHALL BE IN THE FORM REQUIRED BY
30 THE COUNTY AND SHALL BE REQUIRED TO CONTAIN ALL OF AND NOT MORE THAN THE
31 FOLLOWING:

32 1. EACH SERVICE AREA IN WHICH THE APPLICANT INTENDS TO PROVIDE
33 VIDEO SERVICE IN THE FORMAT AS DESCRIBED IN SECTION 11-1911, SUBSECTION C.
34 EXCEPT AS PROVIDED IN SECTION 11-1912, SUBSECTION B, PARAGRAPH 2, UNDER A
35 UNIFORM VIDEO SERVICE LICENSE THE BOUNDARIES OF THE COUNTY ARE A SINGLE
36 SERVICE AREA AND THE SERVICE AREA CONSISTS OF ALL OF THE TERRITORY WITHIN
37 THE BOUNDARIES OF THAT COUNTY.

38 2. THE INFORMATION PRESCRIBED BY SECTION 11-1911, SUBSECTION C,
39 PARAGRAPHS 1 THROUGH 4. THE HOLDER SHALL NOTIFY THE COUNTY IN WRITING OF
40 CHANGES TO THIS INFORMATION WITHIN THIRTY DAYS AFTER THE CHANGE OCCURS.

41 3. THE TERM OF THE UNIFORM VIDEO SERVICE LICENSE, WHICH MAY NOT
42 EXCEED TEN YEARS.

43 4. AN AGREEMENT TO PAY ALL LAWFUL FEES AND CHARGES IMPOSED BY THE
44 COUNTY.

1 C. AN INCUMBENT CABLE OPERATOR DESCRIBED IN SECTION 11-1912,
2 SUBSECTION B, PARAGRAPH 2 MAY ELECT TO APPLY FOR A UNIFORM VIDEO SERVICE
3 LICENSE FOR A SERVICE AREA THAT CONSISTS OF THE BOUNDARIES OF A COUNTY.

4 D. IF THE COUNTY DETERMINES THAT THE APPLICATION AND AFFIDAVIT ARE
5 INCOMPLETE OR OTHERWISE DEFICIENT FOR FAILURE TO COMPLY WITH THIS SECTION,
6 THE COUNTY SHALL PROVIDE WRITTEN NOTICE TO THE APPLICANT NOT LATER THAN
7 FIFTEEN DAYS AFTER THE DATE OF FILING OF THE APPLICATION AND AFFIDAVIT.
8 THE WRITTEN NOTICE SHALL DO BOTH OF THE FOLLOWING:

- 9 1. EXPLAIN THE INCOMPLETENESS OR DEFICIENCY IN DETAIL.
10 2. SPECIFY THE INFORMATION OR OTHER ITEMS THAT ARE NECESSARY UNDER
11 THIS SECTION FOR PROPER COMPLETION OF THE APPLICATION AND AFFIDAVIT.

12 E. THE COUNTY MAY NOT DO ANY OF THE FOLLOWING:

- 13 1. CHARGE A FEE FOR FILING OR PROCESSING AN APPLICATION, AFFIDAVIT,
14 NOTICE OR OTHER DOCUMENT UNDER THIS CHAPTER.
15 2. VOTE ON OR TAKE OTHER OFFICIAL ACTION REGARDING THE APPLICATION,
16 AFFIDAVIT, NOTICE OR OTHER DOCUMENT.
17 3. REQUIRE THE APPLICANT TO OBTAIN THE APPROVAL OF THE COUNTY
18 REGARDING THE APPLICATION, AFFIDAVIT, NOTICE OR OTHER DOCUMENT.
19 4. REQUIRE THE APPLICANT TO ENTER INTO AN AGREEMENT AS DESCRIBED IN
20 SECTION 11-1942, SUBSECTION I.

21 11-1915. Authority granted by uniform video service license:
22 conditions and limitations prohibited; providing
23 video service

24 A. WITHIN THE TIME FRAME THAT THE COUNTY HAS IN PLACE UNDER SECTION
25 11-1605 BUT NOT LATER THAN FORTY-FIVE DAYS AFTER THE DATE AN APPLICANT
26 FILES A COMPLETED APPLICATION AND AFFIDAVIT PURSUANT TO SECTION 11-1914,
27 THE COUNTY SHALL ISSUE A UNIFORM VIDEO SERVICE LICENSE TO THE APPLICANT IN
28 THE FORM PRESCRIBED BY SECTION 11-1911. IF THE COUNTY DOES NOT NOTIFY THE
29 APPLICANT ABOUT THE COMPLETENESS OF THE UNIFORM VIDEO SERVICE LICENSE
30 AGREEMENT WITHIN THE TIME PERIOD PRESCRIBED BY SECTION 11-1914, SUBSECTION
31 D OR ISSUE THE AGREEMENT WITHIN THE TIME PERIOD REQUIRED UNDER THIS
32 SUBSECTION, THE AGREEMENT SHALL BE CONSIDERED COMPLETE AND ISSUED TO THE
33 APPLICANT IN THE FORM SUBMITTED.

34 B. THE UNIFORM VIDEO SERVICE LICENSE ISSUED TO AN APPLICANT,
35 INCLUDING AN INCUMBENT CABLE OPERATOR, BY A COUNTY IS A NONEXCLUSIVE
36 LICENSE GRANTING TO THE HOLDER OF THE UNIFORM VIDEO SERVICE LICENSE THE
37 AUTHORITY FOR THE TERM REQUESTED IN THE APPLICATION TO DO ALL OF THE
38 FOLLOWING:

- 39 1. PROVIDE VIDEO SERVICE IN ALL SERVICE AREAS DESIGNATED IN THE
40 APPLICATION AND AFFIDAVIT FILED WITH THE COUNTY.
41 2. CONSTRUCT AND OPERATE A VIDEO SERVICE NETWORK IN THE HIGHWAYS IN
42 EACH SERVICE AREA IN COMPLIANCE WITH THIS CHAPTER AND ALL LOCAL LAWS THAT
43 CONFORM TO THIS CHAPTER AND THE PURPOSES AND OBJECTIVES OF THIS CHAPTER.

1 C. A COUNTY MAY NOT CONDITION OR LIMIT A UNIFORM VIDEO SERVICE
2 LICENSE BY IMPOSING ANY OBLIGATION OR REQUIREMENT THAT IS NOT AUTHORIZED
3 BY THIS CHAPTER, INCLUDING ANY OF THE FOLLOWING:

4 1. ANY OFFICE LOCATION, INSTITUTIONAL NETWORK OR OTHER BUILD-OUT,
5 LINE EXTENSION, INVESTMENT OR OTHER REQUIREMENTS RELATING TO THE OVERALL
6 SCOPE, EXTENT AND TIMING OF INFRASTRUCTURE, FACILITIES OR DEPLOYMENT OF
7 EQUIPMENT.

8 2. ANY REQUIREMENTS TO PAY TO ANY PERSON ANY APPLICATION, DOCUMENT,
9 LICENSE, SERVICE OR OTHER FEE, TAX, CHARGE OR ASSESSMENT THAT IS NOT
10 AUTHORIZED BY THIS CHAPTER.

11 D. A HOLDER OF A UNIFORM VIDEO SERVICE LICENSE SHALL PROVIDE VIDEO
12 SERVICE IN ACCORDANCE WITH THE CERTIFICATIONS MADE BY THE HOLDER IN EACH
13 APPLICATION AND AFFIDAVIT THAT THE HOLDER FILES WITH THE COUNTY PURSUANT
14 TO THIS ARTICLE.

15 11-1916. Amendment of uniform video service license to add
16 service area

17 A. TO ADD ONE OR MORE NEW SERVICE AREAS TO A UNIFORM VIDEO SERVICE
18 LICENSE, THE HOLDER SHALL FILE WITH THE CLERK OF THE COUNTY AN APPLICATION
19 FOR AN AMENDMENT TO THE UNIFORM VIDEO SERVICE LICENSE TO ADD EACH NEW
20 SERVICE AREA.

21 B. THE APPLICATION IS SUBJECT TO THE SAME PROCEDURES, REQUIREMENTS,
22 LIMITATIONS AND TIME PERIODS AS AN APPLICATION FOR ISSUANCE OF A UNIFORM
23 VIDEO SERVICE LICENSE PURSUANT TO SECTIONS 11-1914 AND 11-1915.

24 11-1917. Termination of service

25 A. TO TERMINATE THE AUTHORITY TO PROVIDE VIDEO SERVICE TO AN
26 EXISTING SERVICE AREA AUTHORIZED UNDER THE UNIFORM VIDEO SERVICE LICENSE,
27 THE HOLDER OF THE UNIFORM VIDEO SERVICE LICENSE SHALL FILE WITH THE CLERK
28 OF THE COUNTY WRITTEN NOTICE OF THE TERMINATION.

29 B. THE HOLDER MAY TERMINATE SERVICE ON AND AFTER THE DATE THAT THE
30 HOLDER FILES THE WRITTEN NOTICE WITH THE CLERK OF THE COUNTY.

31 C. THE HOLDER SHALL:

32 1. COMPLY WITH APPLICABLE FEDERAL LAWS, INCLUDING RULES AND
33 REGULATIONS OF THE FEDERAL COMMUNICATIONS COMMISSION.

34 2. GIVE ALL AFFECTED SUBSCRIBERS AND COUNTIES NOTICE AT LEAST
35 NINETY DAYS BEFORE TERMINATION OF SERVICE IN ALL OF A SERVICE AREA THAT
36 CONSISTS OF THE BOUNDARIES OF THE COUNTY.

37 11-1918. Boundary change

38 EACH COUNTY WHOSE BOUNDARIES CHANGE SHALL NOTIFY IN A TIMELY MANNER
39 EACH VIDEO SERVICE PROVIDER THAT OPERATES IN THE BOUNDARIES.

40 11-1919. Transfer of uniform video service license

41 A. EXCEPT AS OTHERWISE PROVIDED IN THIS SECTION OR OTHERWISE
42 REQUIRED BY FEDERAL LAW, INCLUDING RULES AND REGULATIONS OF THE FEDERAL
43 COMMUNICATIONS COMMISSION, A UNIFORM VIDEO SERVICE LICENSE IS FULLY
44 TRANSFERABLE TO ANY PERSON WHETHER THE TRANSFER ARISES THROUGH MERGER,
45 SALE, ASSIGNMENT, RESTRUCTURING, CHANGE OF CONTROL OR OTHER TYPE OF

1 TRANSACTION. A TRANSFER DOES NOT INCLUDE AN ASSIGNMENT OF A UNIFORM VIDEO
2 SERVICE LICENSE FOR THE PURPOSE OF SECURING INDEBTEDNESS. A TRANSFER MAY
3 INCLUDE LESS THAN ALL SERVICE AREAS ASSOCIATED WITH A UNIFORM VIDEO
4 SERVICE LICENSE.

5 B. THE HOLDER SHALL FILE WITH THE CLERK OF THE COUNTY WRITTEN
6 NOTICE OF THE TRANSFER OF THE UNIFORM VIDEO SERVICE LICENSE. ON THE
7 FILING OF NOTICE UNDER THIS SUBSECTION, THE TRANSFEREE BECOMES THE HOLDER.

8 11-1920. Extension

9 A. TO EXTEND THE TERM OF A UNIFORM VIDEO SERVICE LICENSE, THE
10 HOLDER OF THE UNIFORM VIDEO SERVICE LICENSE SHALL FILE WITH THE CLERK OF
11 THE COUNTY AT LEAST ONE MONTH BEFORE THE END OF THE TERM OF THE UNIFORM
12 VIDEO SERVICE LICENSE A NOTICE TO EXTEND THE TERM FOR A SPECIFIED PERIOD
13 NOT TO EXCEED TEN YEARS.

14 B. EFFECTIVE ON THE DATE THE HOLDER FILES THE WRITTEN NOTICE WITH
15 THE CLERK OF THE COUNTY, THE TERM IS EXTENDED FOR THE SPECIFIED PERIOD
16 FROM AND AFTER THE DATE OF THE END OF THE THEN-CURRENT TERM.

17 C. TRANSFERRING, AMENDING OR MODIFYING A UNIFORM VIDEO SERVICE
18 LICENSE UNDER OTHER SECTIONS OF THIS ARTICLE DOES NOT EXTEND THE TERM OF
19 THE UNIFORM VIDEO SERVICE LICENSE.

20 11-1921. Subscriber complaints

21 A. A SUBSCRIBER MAY SUBMIT COMPLAINTS ABOUT VIDEO SERVICE TO ANY OF
22 THE FOLLOWING:

- 23 1. THE COUNTY WHERE THE SUBSCRIBER RESIDES.
- 24 2. THE ATTORNEY GENERAL.
- 25 3. THE FEDERAL COMMUNICATIONS COMMISSION.
- 26 4. OTHER AUTHORITIES AS PROVIDED BY LAW.

27 B. A COUNTY MAY CHOOSE TO MONITOR AND ASSIST SUBSCRIBERS WITH THE
28 SUBSCRIBER SERVICE STANDARDS PURSUANT TO 47 CODE OF FEDERAL REGULATIONS
29 SECTION 76.309(c) OR TO BE IDENTIFIED ON BILLS TO SUBSCRIBERS AS THE LOCAL
30 FRANCHISE AUTHORITY FOR A SERVICE AREA CONSISTENT WITH RULES OF THE
31 FEDERAL COMMUNICATIONS COMMISSION.

32 ARTICLE 3. DUTIES OF VIDEO SERVICE PROVIDERS

33 11-1931. Video service; revocation for nonuse

34 A. NOT LATER THAN TWENTY-FOUR MONTHS AFTER THE DATE THAT A COUNTY
35 ISSUES A UNIFORM VIDEO SERVICE LICENSE PURSUANT TO SECTIONS 11-1914 AND
36 11-1915 OR AN AMENDED UNIFORM VIDEO SERVICE LICENSE PURSUANT TO SECTION
37 11-1916, THE HOLDER OF THE UNIFORM VIDEO SERVICE LICENSE SHALL OFFER AND
38 PROVIDE VIDEO SERVICE TO AT LEAST ONE SUBSCRIBER WITHIN EACH SERVICE AREA
39 AUTHORIZED BY THE UNIFORM VIDEO SERVICE LICENSE OR AMENDED UNIFORM VIDEO
40 SERVICE LICENSE UNLESS THE HOLDER CANNOT MEET THE REQUIREMENT FOR REASONS
41 BEYOND THE HOLDER'S CONTROL.

42 B. IF A HOLDER FAILS TO COMPLY WITH SUBSECTION A OF THIS SECTION, A
43 COUNTY MAY REVOKE THE HOLDER'S UNIFORM VIDEO SERVICE LICENSE FOR AFFECTED
44 SERVICE AREAS.

1 11-1932. Reports; confidentiality; definition

2 A. A VIDEO SERVICE PROVIDER THAT IS NOT AN INCUMBENT CABLE OPERATOR
3 AND THAT HOLDS A UNIFORM VIDEO SERVICE LICENSE WITH A SERVICE AREA WITHIN
4 THE BOUNDARIES OF A COUNTY SHALL PREPARE AND SUBMIT TO THE COUNTY A
5 SEMIANNUAL REPORT THAT IDENTIFIES THE LOCATIONS WITHIN THE BOUNDARIES THAT
6 ARE ABLE TO RECEIVE VIDEO SERVICE FROM THE VIDEO SERVICE PROVIDER. THIS
7 REPORTING REQUIREMENT APPLIES UNTIL THE VIDEO SERVICE PROVIDER HAS
8 CONSTRUCTED ALL OF THE FACILITIES THE VIDEO SERVICE PROVIDER INTENDS TO
9 CONSTRUCT WITHIN THE BOUNDARIES OF THE COUNTY.

10 B. THE VIDEO SERVICE PROVIDER SHALL FILE THE REPORT WITH THE COUNTY
11 NOT LATER THAN TWENTY DAYS AFTER THE LAST DAY OF THE SECOND AND FOURTH
12 CALENDAR QUARTERS OF EACH YEAR.

13 C. INFORMATION CONTAINED IN A REPORT THAT IS SUBMITTED TO A COUNTY
14 PURSUANT TO THIS SECTION:

15 1. IS CONFIDENTIAL PROPRIETARY INFORMATION OF THE VIDEO SERVICE
16 PROVIDER.

17 2. IS NOT A PUBLIC RECORD.

18 3. MUST BE MANAGED SO THAT ANY CRITICAL INFRASTRUCTURE INFORMATION
19 CONTAINED IN THE REPORT IS PROTECTED AS PROVIDED BY LAW.

20 4. MAY NOT BE DISCLOSED TO ANY PERSON WHO IS NOT AN OFFICER OR
21 EMPLOYEE OF THE COUNTY UNLESS THE VIDEO SERVICE PROVIDER HAS CONSENTED IN
22 WRITING TO THE DISCLOSURE.

23 D. FOR THE PURPOSES OF THIS SECTION, "CRITICAL INFRASTRUCTURE
24 INFORMATION" HAS THE SAME MEANING PRESCRIBED IN SECTION 41-1801.

25 11-1933. Nondiscriminatory manner; compliance with standards
26 and federal law

27 A. A VIDEO SERVICE PROVIDER SHALL ACTIVATE AND OFFER VIDEO SERVICE
28 IN A NONDISCRIMINATORY MANNER WITHIN EACH SERVICE AREA AND MAY NOT DENY
29 ACCESS TO VIDEO SERVICE TO ANY GROUP OF POTENTIAL RESIDENTIAL SUBSCRIBERS
30 WITHIN A PARTICULAR PART OF A SERVICE AREA BECAUSE OF THE INCOME PROFILE
31 OF THE PERSONS WHO RESIDE IN THAT PART OF THE SERVICE AREA.

32 B. IN PROVIDING VIDEO SERVICE, A VIDEO SERVICE PROVIDER SHALL
33 COMPLY WITH ALL OF THE FOLLOWING:

34 1. 47 UNITED STATES CODE SECTION 551.

35 2. ALL ENGINEERING AND SAFETY CODES APPLICABLE TO THE VIDEO SERVICE
36 PROVIDER'S CONSTRUCTION PRACTICES AND INSTALLATION OF EQUIPMENT.

37 3. ANY TECHNICAL STANDARDS GOVERNING THE DESIGN, CONSTRUCTION AND
38 OPERATION OF A VIDEO SERVICE NETWORK REQUIRED BY FEDERAL LAW.

39 4. 47 CODE OF FEDERAL REGULATIONS PART 11, AS ADOPTED AND AS MAY BE
40 AMENDED BY THE FEDERAL COMMUNICATIONS COMMISSION, TO THE EXTENT THOSE
41 PROVISIONS REQUIRE A VIDEO SERVICE PROVIDER TO PARTICIPATE IN THE
42 EMERGENCY ALERT SYSTEM.

43 5. 47 CODE OF FEDERAL REGULATIONS SECTIONS 76.309, 76.1601,
44 76.1602, 76.1603, 76.1604, 76.1618, 76.1619, 76.1620, 76.1621 AND 76.1622,
45 AS ADOPTED AND AS MAY BE AMENDED BY THE FEDERAL COMMUNICATIONS COMMISSION,

1 ON STANDARDS GOVERNING THE QUALITY OF VIDEO SERVICE AND SUBSCRIBER
2 SERVICE. A VIDEO SERVICE PROVIDER MAY NOT BE REQUIRED TO COMPLY WITH ANY
3 SUBSCRIBER SERVICE STANDARDS THAT ARE MORE BURDENSOME THAN THOSE SET FORTH
4 IN THIS PARAGRAPH.

5 ARTICLE 4. COUNTIES

6 11-1941. Management of highways; counties; permits or
7 licenses

8 A. IN MANAGING A HIGHWAY UNDER LOCAL LAWS DESCRIBED IN SECTION
9 11-1911, SUBSECTION C, PARAGRAPH 9, A COUNTY MAY MANAGE THE USE OF THE
10 HIGHWAY INCLUDING ALL OF THE FOLLOWING:

11 1. REQUIRING A VIDEO SERVICE PROVIDER THAT IS CONSTRUCTING,
12 INSTALLING, WORKING WITHIN, MAINTAINING OR REPAIRING FACILITIES IN, ON,
13 UNDER OR OVER ANY HIGHWAY TO OBTAIN A CONSTRUCTION, ENCROACHMENT OR
14 OCCUPANCY PERMIT FOR THE WORK.

15 2. INSPECTING THE CONSTRUCTION, INSTALLATION, MAINTENANCE OR REPAIR
16 WORK PERFORMED ON SUCH FACILITIES.

17 3. LIMITING INSTALLATION OF NEW AERIAL FACILITIES.

18 B. IF A VIDEO SERVICE PROVIDER REQUESTS A PERMIT OR INSPECTION, THE
19 COUNTY SHALL GRANT OR DENY THE REQUEST WITHIN THE TIME FRAME THAT THE
20 COUNTY HAS IN PLACE UNDER SECTION 11-1605.

21 C. IF EMERGENCY RESPONSE WORK OR REPAIR BECOMES NECESSARY IN, ON,
22 UNDER OR OVER ANY HIGHWAY, A VIDEO SERVICE PROVIDER MAY BEGIN THAT WORK OR
23 REPAIR WITHOUT PRIOR APPROVAL FROM A COUNTY IF THE VIDEO SERVICE PROVIDER
24 NOTIFIES THE COUNTY AS PROMPTLY AS REASONABLY POSSIBLE AFTER LEARNING THAT
25 THE WORK OR REPAIR IS NECESSARY.

26 11-1942. Fees and charges; emergency alert; damage;
27 undergrounding; wireless facilities; definition

28 A. EXCEPT THE LICENSE FEE ON GROSS REVENUE AUTHORIZED BY SECTION
29 11-1943 AND EXCISE TAXES AS PROVIDED IN SUBSECTION B OF THIS SECTION, A
30 COUNTY MAY NOT LEVY A TAX, RENT, FEE OR CHARGE, HOWEVER DENOMINATED, ON A
31 VIDEO SERVICE PROVIDER FOR THE USE OF THE HIGHWAYS TO PROVIDE VIDEO
32 SERVICE OR LEVY A TAX, FEE OR CHARGE ON THE PRIVILEGE OF ENGAGING IN THE
33 BUSINESS OF PROVIDING VIDEO SERVICE IN THE SERVICE AREA. TAXES, RENTS,
34 FEES AND CHARGES INCLUDE ALL OF THE FOLLOWING:

35 1. ACCESS CHANNEL SUPPORT EXCEPT FOR IN-KIND SERVICES, GOODS OR
36 PAYMENTS AS PROVIDED IN SUBSECTION C OF THIS SECTION.

37 2. RENTAL, APPLICATION, CONSTRUCTION, PERMIT, INSPECTION,
38 INCONVENIENCE AND OTHER FEES AND CHARGES RELATED TO A VIDEO SERVICE
39 PROVIDER'S USE OR OCCUPANCY OF THE HIGHWAYS, INCLUDING THE USE AUTHORIZED
40 BY SUBSECTION D OF THIS SECTION EXCEPT THAT A COUNTY MAY IMPOSE ON A VIDEO
41 SERVICE PROVIDER SOME OR ALL OF THE FEES AND CHARGES DESCRIBED IN THIS
42 PARAGRAPH. A VIDEO SERVICE PROVIDER SHALL OFFSET THE FEES AND CHARGES
43 IMPOSED PURSUANT TO THIS PARAGRAPH AGAINST THE NEXT LICENSE FEE PAYMENT
44 MADE PURSUANT TO SECTION 11-1943.

1 B. ANY EXCISE TAXES OTHERWISE AUTHORIZED BY LOCAL LAW TO BE LEVIED
2 ON THE BUSINESS OF PROVIDING VIDEO SERVICE OR IN RELATION TO USE OF THE
3 HIGHWAYS TO PROVIDE VIDEO SERVICE MAY BE LEVIED ON A VIDEO SERVICE
4 PROVIDER IF THE TAXES ARE LEVIED ONLY ON GROSS REVENUE AND THE RATE OF THE
5 TAXES IS SUBJECT TO THIS SUBSECTION. THIS SUBSECTION DOES NOT AUTHORIZE
6 THE IMPOSITION OF EXCISE TAXES ON INTERSTATE TELECOMMUNICATIONS SERVICE.
7 THE LICENSE FEE AND ANY EXCISE TAXES LEVIED ON GROSS REVENUE CONSTITUTE A
8 FRANCHISE FEE WITHIN THE MEANING OF THE TERM IN 47 UNITED STATES CODE
9 SECTION 542(g). THE TOTAL OF THE RATES OF THE LICENSE FEE AND OF ANY
10 EXCISE TAXES ON GROSS REVENUE LEVIED OR ASSESSED BY A COUNTY FOR THE
11 PRIVILEGE OF PROVIDING VIDEO SERVICE AND RELATED USE OF THE HIGHWAYS TO
12 PROVIDE VIDEO SERVICE MAY NOT EXCEED A RATE OF FIVE PERCENT.

13 C. SUBSECTION A OF THIS SECTION DOES NOT PROHIBIT A COUNTY FROM
14 LEVYING FEES AND CHARGES ON A VIDEO SERVICE PROVIDER OR ITS AFFILIATES
15 PURSUANT TO SECTION 9-584 OR CHAPTER 13, ARTICLE 1 OF THIS TITLE WITHOUT
16 AN OFFSET AGAINST LICENSE FEES.

17 D. A COUNTY MAY NOT REQUIRE A VIDEO SERVICE PROVIDER TO PROVIDE
18 IN-KIND GOODS OR SERVICES, MAKE IN-KIND PAYMENTS, ASSESSMENTS OR
19 OBLIGATIONS OR PAY A FEE IN ADDITION TO THE MONETARY LICENSE FEE LEVIED OR
20 ASSESSED AS PROVIDED IN SECTION 11-1943, EXCEPT FOR ANY OF THE FOLLOWING:

21 1. A LOCAL LAW MAY IMPOSE AND ENFORCE OBLIGATIONS EQUALLY AND
22 UNIFORMLY ON ALL VIDEO SERVICE PROVIDERS THAT ARE OPERATING WITHIN THE
23 BOUNDARIES OF A COUNTY AND ON ALL HOLDOVER CABLE OPERATORS THAT HOLD A
24 LOCAL LICENSE THAT REMAINS IN EFFECT UNDER SECTION 11-1914, SUBSECTION A.
25 UNDER THE LOCAL LAW, A COUNTY:

26 (a) MAY REQUIRE ALL VIDEO SERVICE PROVIDERS TO PROVIDE CHANNEL
27 CAPACITY FOR THE VIDEO SERVICE PROVIDER TO TRANSMIT PROGRAMMING OVER WHICH
28 THE VIDEO SERVICE PROVIDER EXERCISES NO EDITORIAL CONTROL EXCEPT AS
29 AUTHORIZED BY 47 UNITED STATES CODE SECTION 531(e). THE CHANNEL CAPACITY
30 SHALL BE LIMITED TO ONE OF THE FOLLOWING:

31 (i) NOT MORE THAN TWO CHANNELS OF PUBLIC, EDUCATIONAL OR
32 GOVERNMENTAL ACCESS PROGRAMMING IN THE BASIC SERVICE TIER OF THE VIDEO
33 SERVICE NETWORK AND NOT MORE THAN TWO CHANNELS OF NONCOMMERCIAL
34 GOVERNMENTAL PROGRAMMING, AT LEAST ONE OF WHICH MAY BE PROGRAMMED BY THE
35 FEDERAL GOVERNMENT, IN THE DIGITAL PROGRAMMING TIER OF THE VIDEO SERVICE
36 NETWORK.

37 (ii) NOT MORE THAN TWO LINES OF ACCESS PROGRAMMING WITH EACH LINE
38 OF PROGRAMMING CARRIED ON UP TO TWO STANDARD DEFINITION CHANNELS AND TWO
39 SWITCHED DIGITAL HIGH-DEFINITION CHANNELS.

40 (b) SHALL SPECIFY THE PROGRAMMING AND THE VIDEO SERVICE PROVIDER
41 MAY REQUIRE THAT THE CHANNELS REGULARLY DISPLAY AN UNOBTRUSIVE LOGO OR
42 OTHER SUITABLE IDENTIFIER OF THE VIDEO SERVICE PROVIDER, IF THE COUNTY
43 REQUIRES CHANNEL CAPACITY PURSUANT TO SUBDIVISION (a) OF THIS PARAGRAPH.

1 (c) MAY REQUIRE ALL VIDEO SERVICE PROVIDERS TO INCUR COSTS AND
2 EXPENSES TO PROVIDE, MAINTAIN AND OPERATE FACILITIES AND EQUIPMENT OF THE
3 VIDEO SERVICE NETWORK, INCLUDING FACILITIES AND EQUIPMENT FOR SIGNAL
4 CARRIAGE, PROCESSING, REFORMATTING AND INTERCONNECTION FOR ALL OF THE
5 FOLLOWING:

6 (i) TO CONNECT THE VIDEO SERVICE NETWORK OR CABLE SYSTEM, AS IT MAY
7 BE RELOCATED FROM TIME TO TIME, TO TRANSMIT PROGRAMMING TO AND FROM
8 EXISTING LOCATIONS OF PUBLIC, EDUCATIONAL OR GOVERNMENTAL ACCESS
9 FACILITIES AND TO ALLOW MONITORING OF ACCESS PROGRAMMING AT THE
10 FACILITIES.

11 (ii) TO TRANSMIT PUBLIC, EDUCATIONAL AND GOVERNMENTAL ACCESS
12 CHANNELS TO SUBSCRIBERS WITH THE SAME PREVAILING QUALITY, FUNCTIONALITY
13 AND IDENTIFICATION AS OTHER CHANNELS.

14 (d) MAY REQUIRE ALL VIDEO SERVICE PROVIDERS AND INCUMBENT CABLE
15 OPERATORS TO PROVIDE AT NO INITIAL OR RECURRING CHARGE THE BASIC SERVICE
16 TIER OF VIDEO SERVICE TO ONE OUTLET AND ONE RECEIVING DEVICE AT EACH
17 BUILDING OCCUPIED BY THE COUNTY IF THE BUILDING IS NOT MORE THAN TWO
18 HUNDRED FEET FROM THE NEAREST TECHNICALLY AND COMMERCIALY FEASIBLE POINT
19 OF CONNECTION ON THE VIDEO SERVICE NETWORK.

20 2. A COUNTY MAY RETAIN NONRECEIVING EQUIPMENT THAT IT OWNS WITHOUT
21 CHARGE FOR THE EQUIPMENT'S USE AND AT THE COUNTY'S EXPENSE, INCLUDING
22 EQUIPMENT PREVIOUSLY PROVIDED BY AN INCUMBENT CABLE OPERATOR.

23 E. A LOCAL LAW MAY NOT IMPOSE ANY OBLIGATION ON A VIDEO SERVICE
24 PROVIDER UNDER SUBSECTION D OF THIS SECTION THAT IS MORE BURDENSOME THAN
25 THE LEAST BURDENSOME REQUIREMENT UNDER ANY LOCAL LICENSE WITH A SERVICE
26 AREA WITHIN THE BOUNDARIES OF THE COUNTY THAT WAS IN EFFECT ON FEBRUARY 1,
27 2019.

28 F. NONE OF THE ANNUAL FAIR MARKET VALUE OF ANY CHANNEL CAPACITY
29 PROVIDED PURSUANT TO SUBSECTION D, PARAGRAPH 1, SUBDIVISION (a), THE
30 ANNUAL COSTS AND EXPENSES INCURRED PURSUANT TO SUBSECTION D, PARAGRAPH 1,
31 SUBDIVISION (c) AND THE ANNUAL FAIR MARKET VALUE OF BASIC SERVICE AND LINE
32 EXTENSION PROVIDED PURSUANT TO SUBSECTION D, PARAGRAPH 1, SUBDIVISION (d)
33 MAY BE OFFSET AGAINST THE LICENSE FEE LEVIED OR ASSESSED UNDER THIS
34 SECTION.

35 G. NOTWITHSTANDING SUBSECTION A OF THIS SECTION, BY A
36 NONDISCRIMINATORY LOCAL LAW THAT IMPOSES AND ENFORCES THE OBLIGATIONS
37 EQUALLY AND UNIFORMLY ON ALL VIDEO SERVICE PROVIDERS OPERATING WITHIN THE
38 BOUNDARIES OF A COUNTY, A COUNTY MAY REQUIRE THAT A VIDEO SERVICE PROVIDER
39 BEAR ALL OF THE REASONABLE COSTS THAT ARE ASSOCIATED WITH REPAIR AND
40 RESTORATION OF DAMAGE CAUSED TO PRIVATE PROPERTY OR HIGHWAYS BY THE
41 REPAIR, REPLACEMENT, INSTALLATION, CONSTRUCTION, MAINTENANCE OR OPERATION
42 OF THE VIDEO SERVICE PROVIDER'S FACILITIES IN THE HIGHWAYS AND THAT ARE
43 IMPOSED ON A COMPETITIVELY NEUTRAL AND NONDISCRIMINATORY BASIS IN RELATION
44 TO COSTS BORNE BY TELECOMMUNICATIONS CORPORATIONS UNDER SECTION 9-582,
45 SUBSECTION C.

1 H. ON APPLICATION, A COUNTY SHALL ISSUE TO A VIDEO SERVICE PROVIDER
2 OR ITS AFFILIATE A PERMIT TO ATTACH ALLOWED WI-FI RADIO EQUIPMENT TO THE
3 VIDEO SERVICE NETWORK IN THE HIGHWAYS WITHIN THE BOUNDARIES OF THE COUNTY.
4 THE PERMIT SHALL ALLOW INSTALLATION, OPERATION AND MAINTENANCE OF ALLOWED
5 WI-FI RADIO EQUIPMENT. A COUNTY MAY REQUIRE THAT ALL OF THE ALLOWED WI-FI
6 RADIO EQUIPMENT AT A SINGLE LOCATION FIT WITHIN A FIFTEEN-INCH CUBE AND BE
7 CONTAINED ENTIRELY WITHIN A GROUND-MOUNTED PEDESTAL OR BE CONNECTED
8 DIRECTLY TO AND MOUNTED AT THE SAME HEIGHT AS ONE OF THE VIDEO SERVICE
9 PROVIDER'S AERIAL HORIZONTAL CONDUCTORS. THIS SUBSECTION DOES NOT DO ANY
10 OF THE FOLLOWING:

11 1. PROHIBIT A COUNTY FROM REQUIRING A VIDEO SERVICE PROVIDER TO
12 PLACE UNDERGROUND AERIAL FACILITIES TO WHICH ALLOWED WI-FI EQUIPMENT IS
13 ATTACHED.

14 2. PROHIBIT THE IMPOSITION OF A TAX, RENT, FEE OR CHARGE ON REVENUE
15 FROM SERVICES PROVIDED THROUGH ALLOWED WI-FI RADIO EQUIPMENT.

16 3. AFFECT THE AUTHORITY OF A COUNTY TO MANAGE THE HIGHWAYS WITHIN
17 ITS BOUNDARIES OR TO EXERCISE ITS POLICE POWERS, INCLUDING REVIEW AND
18 APPROVAL OF AN APPLICATION BEFORE ISSUING A PERMIT.

19 4. AFFECT ANY AUTHORITY OF A POLITICAL SUBDIVISION, INCLUDING AN
20 AGRICULTURAL IMPROVEMENT DISTRICT OR ANY OTHER SPECIAL TAXING DISTRICT,
21 THE COUNTY OR ANY OTHER PERSON CONTROLLING UTILITY POLES IN THE HIGHWAYS
22 TO DENY, LIMIT, RESTRICT OR DETERMINE THE TERMS AND CONDITIONS FOR THE USE
23 OF OR ATTACHMENT TO THE UTILITY POLES OR ATTACHMENTS TO OTHER POLES OF THE
24 POLITICAL SUBDIVISION, COUNTY OR OTHER PERSON BY A VIDEO SERVICE PROVIDER.

25 I. THIS SECTION DOES NOT PROHIBIT A VIDEO SERVICE PROVIDER FROM
26 AGREEING WITH A COUNTY TO PROVIDE IN-KIND SERVICES OR GOODS OR MAKE
27 IN-KIND PAYMENTS IN THE SERVICE AREA THAT ARE OTHERWISE PROHIBITED BY THIS
28 SECTION IF THE AGREEMENT WITH THE COUNTY IS NOT ENTERED INTO AS A
29 CONDITION OF OPERATING IN THE SERVICE AREA UNDER A UNIFORM VIDEO SERVICE
30 LICENSE ISSUED PURSUANT TO THIS CHAPTER. THE AGREEMENT MAY AUTHORIZE THE
31 VIDEO SERVICE PROVIDER TO RETAIN LICENSE FEES AND TAXES COLLECTED FROM ITS
32 SUBSCRIBERS IN THE AMOUNT OF ANY OFFSET TO LICENSE FEES SPECIFIED IN THE
33 AGREEMENT.

34 J. FOR THE PURPOSES OF THIS SECTION, "ALLOWED WI-FI RADIO
35 EQUIPMENT" MEANS RADIO EQUIPMENT THAT USES ONLY UNLICENSED RADIO SPECTRUM
36 AND THAT ENABLES WIRELESS COMMUNICATION WITH A COMMUNICATIONS NETWORK FOR
37 UNLICENSED SERVICES SUCH AS WI-FI SERVICE.

38 11-1943. License fee; requirements; conditions and
39 limitations; pass through to subscribers

40 A. FOR THE PRIVILEGE OF A VIDEO SERVICE PROVIDER TO OCCUPY OR USE,
41 IN WHOLE OR IN PART, ANY HIGHWAY WITHIN THE BOUNDARIES OF A COUNTY TO
42 PROVIDE VIDEO SERVICE THROUGH A VIDEO SERVICE NETWORK, THE COUNTY MAY
43 REQUIRE A VIDEO SERVICE PROVIDER TO PAY A LICENSE FEE TO THE COUNTY BASED
44 ON THE GROSS REVENUE THAT THE VIDEO SERVICE PROVIDER RECEIVES FROM ITS

1 SUBSCRIBERS LOCATED WITHIN THE BOUNDARIES OF THE COUNTY. THE LICENSE FEE
2 BOTH:

3 1. IS SUBJECT TO THE LIMIT PRESCRIBED BY SECTION 11-1942,
4 SUBSECTION B AND TO OFFSET, INCLUDING AMOUNTS COLLECTED FROM SUBSCRIBERS,
5 AS PRESCRIBED BY SECTION 11-1942, SUBSECTIONS A AND I AND SUBSECTION D OF
6 THIS SECTION.

7 2. SHALL BE DUE NO MORE OFTEN THAN QUARTERLY.

8 B. IF THE COUNTY REQUIRES A LICENSE FEE PURSUANT TO SUBSECTION A OF
9 THIS SECTION, THE COUNTY SHALL ADOPT A LOCAL LAW THAT IMPOSES THE LICENSE
10 FEE EQUALLY AND UNIFORMLY ON ALL OF THE FOLLOWING THAT ARE OPERATING
11 WITHIN THE BOUNDARIES OF THE COUNTY:

12 1. VIDEO SERVICE PROVIDERS.

13 2. HOLDOVER CABLE OPERATORS.

14 C. A VIDEO SERVICE PROVIDER SHALL PAY THE ENTIRE AMOUNT OF THE
15 LICENSE FEE DIRECTLY TO THE COUNTY IN A CHECK, DRAFT OR NOTE OR AUTOMATED
16 CLEARINGHOUSE TRANSACTION THAT IS PAYABLE IN LEGAL TENDER AS DEFINED IN
17 SECTION 43-1021.

18 D. A VIDEO SERVICE PROVIDER MAY DO ALL OF THE FOLLOWING:

19 1. PASS THE LICENSE FEE THROUGH TO AND COLLECT THE LICENSE FEE FROM
20 ITS SUBSCRIBERS WITHIN THE BOUNDARIES OF THE COUNTY, INCLUDING FOR AN
21 INCUMBENT CABLE OPERATOR ANY CHANGE IN LICENSE FEES THAT RESULTS FROM A
22 CHANGE IN THE APPLICABLE DEFINITION OF GROSS REVENUE.

23 2. DESIGNATE THE AMOUNT OF THE LICENSE FEE COLLECTED FROM EACH
24 SUBSCRIBER AS A SEPARATE LINE ITEM ON THE SUBSCRIBER'S BILL.

25 11-1944. Ownership of a video service network

26 EXCEPT FOR THE PURPOSES OF ACTING AS AN INTERMEDIARY IN A TRANSFER
27 OF A UNIFORM VIDEO SERVICE LICENSE, A COUNTY MAY NOT OWN A VIDEO SERVICE
28 NETWORK.

29 11-1945. Review and audit; bundling discounts; action to
30 recover underpayment or overpayment

31 A. NOT MORE THAN ONCE EVERY THREE YEARS, A COUNTY, ON REASONABLE
32 WRITTEN NOTICE, MAY AUDIT THE BUSINESS BOOKS AND RECORDS OF A VIDEO
33 SERVICE PROVIDER TO THE EXTENT NECESSARY TO ENSURE PAYMENT OF LICENSE FEES
34 PURSUANT TO THIS CHAPTER. THE COUNTY MAY NOT AUDIT ANY PERIOD THAT ENDS
35 MORE THAN THREE YEARS BEFORE THE DATE THAT THE NOTICE OF AUDIT IS
36 RECEIVED. ANY AUDIT OF A PERIOD OF TIME BEFORE ISSUANCE OF A UNIFORM
37 VIDEO SERVICE LICENSE SHALL BE CONDUCTED PURSUANT TO THE LOCAL LAWS IN
38 EFFECT DURING THE PERIOD OF TIME.

39 B. EXCEPT AS OTHERWISE PROVIDED BY FEDERAL LAW, IF A VIDEO SERVICE
40 PROVIDER OFFERS VIDEO SERVICE BUNDLED WITH OTHER SERVICES THAT ARE NOT
41 VIDEO SERVICE FOR A SINGLE DISCOUNTED PRICE, ALL OF THE FOLLOWING APPLY:

42 1. THE METHOD THAT THE VIDEO SERVICE PROVIDER USES TO DETERMINE
43 GROSS REVENUE SUBJECT TO LICENSE FEES BY ALLOCATING THE SINGLE DISCOUNTED
44 PRICE AMONG THE BUNDLE OF VIDEO SERVICE AND NONVIDEO SERVICES SHALL BE

1 REASONABLE AND SUPPORTED BY THE VIDEO SERVICE PROVIDER'S BOOKS AND
2 RECORDS.

3 2. THE COUNTY SHALL ACCEPT AS REASONABLE, FOR PURPOSES OF MEETING
4 THE VIDEO SERVICE PROVIDER'S BURDEN OF PROOF, AN ALLOCATION BASED ON AN
5 OBJECTIVE AND VERIFIABLE METHOD USING THE BOOKS AND RECORDS THAT THE VIDEO
6 SERVICE PROVIDER KEPT IN THE REGULAR COURSE OF BUSINESS FOR OTHER
7 PURPOSES, INCLUDING NONTAX PURPOSES.

8 3. A VIDEO SERVICE PROVIDER MAY NOT USE BUNDLED OFFERINGS AS A
9 MEANS TO EVADE PAYING LICENSE FEES.

10 C. THE COUNTY AND THE VIDEO SERVICE PROVIDER SHALL EACH PAY ITS OWN
11 COSTS AND FEES RELATING TO EACH AUDIT PERFORMED PURSUANT TO SUBSECTION A
12 OF THIS SECTION. IF THE SUM DETERMINED TO BE UNDERPAID EXCEEDS FIVE
13 PERCENT OF THE TOTAL FEES THAT THE AUDIT DETERMINES SHOULD HAVE BEEN PAID
14 FOR THE PERIOD, THE VIDEO SERVICE PROVIDER SHALL PAY THE COUNTY'S
15 REASONABLE COSTS OF THE AUDIT.

16 D. THE RATE OF INTEREST FOR BOTH UNDERPAYMENTS AND OVERPAYMENTS IS
17 THE FEDERAL SHORT-TERM RATE, DETERMINED PURSUANT TO 26 UNITED STATES CODE
18 SECTION 6621(b), PLUS THREE PERCENTAGE POINTS.

19 E. A PERSON THAT PERFORMS A REVIEW AND AUDIT UNDER SUBSECTION A OF
20 THIS SECTION MAY NOT RECEIVE COMPENSATION THAT IS BASED, IN WHOLE OR IN
21 PART, ON EITHER OF THE FOLLOWING:

22 1. FINDING A PARTICULAR RESULT.

23 2. THE AMOUNT OF ANY UNDERPAYMENT OR OVERPAYMENT OF THE LICENSE FEE
24 THAT IS IDENTIFIED BECAUSE OF THE REVIEW AND AUDIT.

25 F. A COMPLAINT BY A COUNTY FOR UNDERPAYMENT OF A LICENSE FEE FROM A
26 VIDEO SERVICE PROVIDER OR BY A VIDEO SERVICE PROVIDER FOR OVERPAYMENT OF A
27 LICENSE FEE TO A COUNTY SHALL BE MADE PURSUANT TO ARTICLE 5 OF THIS
28 CHAPTER.

29 G. A COMPLAINT FOR A VIOLATION OF THE LICENSE FEE OBLIGATIONS UNDER
30 THIS CHAPTER MAY NOT BE MADE UNLESS A WRITTEN DEMAND BY A COUNTY FOR
31 PAYMENT OF THE LICENSE FEES OR A WRITTEN DEMAND BY A VIDEO SERVICE
32 PROVIDER FOR REFUND OF LICENSE FEES IS MADE WITHIN FOUR MONTHS AFTER THE
33 COUNTY OR VIDEO SERVICE PROVIDER REALIZES IT HAS BEEN DAMAGED OR KNOWS OR
34 REASONABLY SHOULD KNOW OF THE DAMAGE CAUSED BY THE ALLEGED VIOLATION.

35 H. A COMPLAINT MUST BE FILED PURSUANT TO ARTICLE 5 OF THIS CHAPTER
36 WITHIN TWO YEARS AFTER THE WRITTEN DEMAND IS MADE PURSUANT TO SUBSECTION G
37 OF THIS SECTION BUT NOT SOONER THAN FOUR MONTHS AFTER THE WRITTEN DEMAND.

38 ARTICLE 5. ENFORCEMENT

39 11-1951. Enforcement; office of administrative hearings; fees

40 A. A COUNTY MAY FILE A WRITTEN COMPLAINT AGAINST A VIDEO SERVICE
41 PROVIDER AND A VIDEO SERVICE PROVIDER MAY FILE A WRITTEN COMPLAINT AGAINST
42 A COUNTY ALLEGING A VIOLATION OF THIS CHAPTER OR THE UNIFORM VIDEO SERVICE
43 LICENSE AGREEMENT. UNLESS OTHERWISE PROVIDED IN SECTION 11-1945,
44 SUBSECTIONS F, G AND H OR THIS SECTION:

1 1. ALL COMPLAINTS MUST BE FILED WITH THE OFFICE OF ADMINISTRATIVE
2 HEARINGS.
3 2. THE COMPLAINANT MUST SERVE A COPY OF THE COMPLAINT ON THE PARTY
4 THAT IS THE SUBJECT OF THE COMPLAINT BY PERSONAL DELIVERY OR CERTIFIED
5 MAIL, RETURN RECEIPT REQUESTED, OR BY ANY OTHER METHOD REASONABLY
6 CALCULATED TO EFFECT ACTUAL NOTICE TO THE COUNTY'S LAST ADDRESS OF RECORD
7 FOR THE PARTY THAT IS THE SUBJECT OF THE COMPLAINT.
8 3. THE PARTY THAT IS THE SUBJECT OF THE COMPLAINT MAY FILE A
9 RESPONSE TO THE COMPLAINT WITH THE OFFICE OF ADMINISTRATIVE HEARINGS
10 WITHIN TWENTY DAYS AFTER SERVICE PURSUANT TO PARAGRAPH 2 OF THIS
11 SUBSECTION. RESPONSES SHALL BE SERVED PURSUANT TO PARAGRAPH 2 OF THIS
12 SUBSECTION.
13 B. BEFORE FILING A COMPLAINT PURSUANT TO THIS SECTION BOTH OF THE
14 FOLLOWING APPLY:
15 1. THE COMPLAINANT MUST PROVIDE NOTICE OF THE ALLEGED VIOLATION OF
16 THIS CHAPTER TO THE PARTY THAT IS THE SUBJECT OF THE COMPLAINT.
17 2. THE PARTY THAT IS THE SUBJECT OF THE COMPLAINT MUST HAVE A
18 PERIOD OF NOT LESS THAN TWENTY DAYS AFTER THE DATE IT RECEIVES THE NOTICE
19 TO RESOLVE THE ALLEGED VIOLATION.
20 C. SUBSECTION B OF THIS SECTION DOES NOT APPLY TO A COMPLAINT MADE
21 IN A WRITTEN DEMAND PURSUANT TO SECTION 11-1945, SUBSECTION G.
22 D. A HEARING BEFORE THE OFFICE OF ADMINISTRATIVE HEARINGS SHALL BE
23 HELD IF A COMPLAINT THAT COMPLIES WITH THIS SECTION IS FILED WITH THE
24 OFFICE OF ADMINISTRATIVE HEARINGS. UNLESS OTHER DEADLINES ARE ESTABLISHED
25 FOR A PARTICULAR COMPLAINT, ALL OF THE FOLLOWING APPLY:
26 1. THE HEARING SHALL BE HELD WITHIN TWO MONTHS AFTER THE DATE THAT
27 THE COMPLAINT IS FILED AND SERVICE IS COMPLETED PURSUANT TO SUBSECTION A
28 OF THIS SECTION.
29 2. THE DATE SCHEDULED FOR THE HEARING MAY BE ADVANCED OR DELAYED ON
30 THE AGREEMENT OF THE PARTIES OR ON A SHOWING OF GOOD CAUSE.
31 E. THE OFFICE OF ADMINISTRATIVE HEARINGS SHALL PREPARE AND SERVE A
32 NOTICE OF HEARING ON ALL PARTIES AT LEAST ONE MONTH BEFORE THE HEARING
33 THAT STATES THE TIME AND PLACE OF THE HEARING.
34 F. A PREHEARING CONFERENCE MAY BE HELD PURSUANT TO SECTION
35 41-1092.05.
36 G. UNLESS IT CONFLICTS WITH THE REQUIREMENTS OF THIS SECTION, THE
37 HEARING SHALL BE CONDUCTED PURSUANT TO SECTION 41-1092.07.
38 H. THE COMPLAINANT HAS THE BURDEN OF PERSUASION AT A HEARING UNDER
39 THIS SECTION.
40 I. THE DECISION OF THE ADMINISTRATIVE LAW JUDGE IS THE FINAL
41 ADMINISTRATIVE DECISION WITH RESPECT TO THE COMPLAINT. THE OFFICE OF
42 ADMINISTRATIVE HEARINGS SHALL SERVE A COPY OF THE ADMINISTRATIVE LAW
43 JUDGE'S DECISION ON ALL PARTIES. THE FINAL ADMINISTRATIVE DECISION MAY BE
44 APPEALED TO THE SUPERIOR COURT PURSUANT TO TITLE 12, CHAPTER 7, ARTICLE 6.
45 THE SUPERIOR COURT PROCEEDING SHALL BE A TRIAL DE NOVO.

1 J. A PARTY MAY MOVE FOR REHEARING PURSUANT TO SECTION 41-1092.09,
2 AND THE OFFICE OF ADMINISTRATIVE HEARINGS SHALL RULE ON THE MOTION.
3 MOVING FOR REHEARING OR REVIEW IS NOT NECESSARY FOR THE PARTY TO SEEK
4 JUDICIAL REVIEW OF THE DECISION OF THE ADMINISTRATIVE LAW JUDGE UNDER
5 SUBSECTION I OF THIS SECTION.

6 K. SERVICE IS COMPLETE ON PERSONAL SERVICE OR FIVE DAYS AFTER THE
7 DATE THAT THE OFFICE OF ADMINISTRATIVE HEARINGS MAILES THE FINAL
8 ADMINISTRATIVE DECISION TO EACH PARTY'S LAST KNOWN ADDRESS OF RECORD WITH
9 THE COUNTY.

10 L. THE OFFICE OF ADMINISTRATIVE HEARINGS SHALL ADOPT RULES PURSUANT
11 TO TITLE 41, CHAPTER 6 TO ADMINISTER HEARINGS UNDER THIS CHAPTER AND TITLE
12 9, CHAPTER 13. THE RULES SHALL APPLY UNIFORMLY TO HEARINGS INVOLVING
13 LOCAL GOVERNMENTS AS DEFINED IN SECTION 9-1401 AND COUNTIES.

14 M. THE OFFICE OF ADMINISTRATIVE HEARINGS SHALL ESTABLISH,
15 ADMINISTER AND COLLECT FEES IN AN AMOUNT TO BE DETERMINED BY THE DIRECTOR
16 OF THE OFFICE OF ADMINISTRATIVE HEARINGS. THE DIRECTOR SHALL DEPOSIT,
17 PURSUANT TO SECTIONS 35-146 AND 35-147, ALL MONIES IN THE VIDEO SERVICE
18 PROVIDER COMPLAINT FUND ESTABLISHED BY SECTION 9-1451, SUBSECTION N.

19 11-1952. Statute of limitations; costs and attorney fees;
20 federal subscriber service requirements

21 A. EXCEPT AS PROVIDED IN SECTION 11-1945, SUBSECTIONS F, G AND H, A
22 COMPLAINT UNDER THIS ARTICLE MUST BE FILED WITHIN TWO YEARS AFTER THE
23 COMPLAINANT REALIZES IT HAS BEEN DAMAGED AND KNOWS OR REASONABLY SHOULD
24 KNOW THE CAUSE, SOURCE, ACT, EVENT, INSTRUMENTALITY OR CONDITION THAT
25 CAUSED OR CONTRIBUTED TO THE ALLEGED VIOLATION.

26 B. EACH PARTY TO A DISPUTE UNDER THIS CHAPTER SHALL BEAR ITS OWN
27 ATTORNEY FEES AND COSTS.

28 C. THIS ARTICLE DOES NOT APPLY TO CLAIMS THAT A VIDEO SERVICE
29 PROVIDER HAS FAILED TO MEET SUBSCRIBER SERVICE STANDARDS PRESCRIBED BY
30 SECTION 11-1933, SUBSECTION B, PARAGRAPH 5 OR HAS VIOLATED TITLE 44,
31 CHAPTER 10, ARTICLE 7. CLAIMS OF VIOLATIONS OF FEDERAL SUBSCRIBER SERVICE
32 STANDARDS SHALL BE MADE PURSUANT TO THE PROCEDURE ESTABLISHED UNDER
33 FEDERAL LAW.

34 Sec. 9. Section 41-1092.01, Arizona Revised Statutes, is amended to
35 read:

36 41-1092.01. Office of administrative hearings; director;
37 powers and duties; fund

38 A. An office of administrative hearings is established.

39 B. The governor shall appoint the director pursuant to section
40 38-211. At a minimum, the director shall have the experience necessary
41 for appointment as an administrative law judge. The director also shall
42 possess supervisory, management and administrative skills, as well as
43 knowledge and experience relating to administrative law.

44 C. The director shall:

45 1. Serve as the chief administrative law judge of the office.

1 2. Make and execute the contracts and other instruments that are
2 necessary to perform the director's duties.

3 3. Subject to chapter 4, article 4 of this title, hire employees,
4 including full-time administrative law judges, and contract for special
5 services, including temporary administrative law judges, that are
6 necessary to carry out this article. An administrative law judge employed
7 or contracted by the office shall have graduated from an accredited
8 college of law or shall have at least two years of administrative or
9 managerial experience in the subject matter or agency section the
10 administrative law judge is assigned to in the office.

11 4. Make rules that are necessary to carry out this article,
12 including rules governing ex parte communications in contested cases.

13 5. Submit a report to the governor, speaker of the house of
14 representatives and president of the senate by November 1 of each year
15 describing the activities and accomplishments of the office. The
16 director's annual report shall include a summary of the extent and effect
17 of agencies' utilization of administrative law judges, court reporters and
18 other personnel in proceedings under this article and recommendations for
19 changes or improvements in the administrative procedure act or any
20 agency's practice or policy with respect to the administrative procedure
21 act. **THE DIRECTOR SHALL PROVIDE A COPY OF THE REPORT TO THE SECRETARY OF**
22 **STATE.**

23 6. Secure, compile and maintain all decisions, opinions or reports
24 of administrative law judges issued pursuant to this article and the
25 reference materials and supporting information that may be appropriate.

26 7. Develop, implement and maintain a program for the continuing
27 training and education of administrative law judges and agencies in regard
28 to their responsibilities under this article. The program shall require
29 that an administrative law judge receive training in the technical and
30 subject matter areas of the sections to which the administrative law judge
31 is assigned.

32 8. Develop, implement and maintain a program of evaluation to aid
33 the director in the evaluation of administrative law judges appointed
34 pursuant to this article that includes comments received from the public.

35 9. Annually report the following to the governor, the president of
36 the senate and the speaker of the house of representatives **AND PROVIDE A**
37 **COPY OF THIS REPORT TO THE SECRETARY OF STATE** by December 1 for the prior
38 fiscal year:

39 (a) The number of administrative law judge decisions rejected or
40 modified by agency heads.

41 (b) By category, the number and disposition of motions filed
42 pursuant to section 41-1092.07, subsection A to disqualify office
43 administrative law judges for bias, prejudice, personal interest or lack
44 of expertise.

1 (c) By agency, the number and type of violations of section
2 41-1009.

3 10. Schedule hearings pursuant to section 41-1092.05 ~~upon~~ ON the
4 request of an agency or the filing of a notice of appeal pursuant to
5 section 41-1092.03.

6 D. The director shall not require legal representation to appear
7 before an administrative law judge.

8 E. Except as provided in subsection F of this section, all state
9 agencies supported by state general fund sources, unless exempted by this
10 article, and the registrar of contractors shall use the services and
11 personnel of the office to conduct administrative hearings. All other
12 agencies shall contract for services and personnel of the office to
13 conduct administrative hearings.

14 F. An agency head, board or commission that directly conducts an
15 administrative hearing as an administrative law judge is not required to
16 use the services and personnel of the office for that hearing.

17 G. Each state agency, and each political subdivision contracting
18 for office services pursuant to subsection I of this section, shall make
19 its facilities available, as necessary, for use by the office in
20 conducting proceedings pursuant to this article.

21 H. The office shall employ full-time administrative law judges to
22 conduct hearings required by this article or other laws as follows:

23 1. The director shall assign administrative law judges from the
24 office to an agency, on either a temporary or a permanent basis, at
25 supervisory or other levels, to preside over contested cases and
26 appealable agency actions in accordance with the special expertise of the
27 administrative law judge in the subject matter of the agency.

28 2. The director shall establish the subject matter and agency
29 sections within the office that are necessary to carry out this
30 article. Each subject matter and agency section shall provide training in
31 the technical and subject matter areas of the section as prescribed in
32 subsection C, paragraph 7 of this section.

33 I. If the office cannot furnish an office administrative law judge
34 promptly in response to an agency request, the director may contract with
35 qualified individuals to serve as temporary administrative law judges.
36 These temporary administrative law judges are not employees of this state.

37 J. The office may provide administrative law judges on a contract
38 basis to any governmental entity to conduct any hearing not covered by
39 this article. The director may enter into contracts with political
40 subdivisions of this state, and these political subdivisions may contract
41 with the director for the purpose of providing administrative law judges
42 and reporters for administrative proceedings or informal dispute
43 resolution. The contract may define the scope of the administrative law
44 judge's duties. Those duties may include the preparation of findings,
45 conclusions, decisions or recommended decisions or a recommendation for

1 action by the political subdivision. For these services, the director
2 shall request payment for services directly from the political subdivision
3 for which the services are performed, and the director may accept payment
4 on either an advance or reimbursable basis.

5 K. The office shall apply monies received pursuant to subsections E
6 and J of this section to offset its actual costs for providing personnel
7 and services.

8 L. The office shall receive complaints against A COUNTY, a local
9 government AS DEFINED IN SECTION 9-1401 or a video service provider as
10 defined in section 9-1401 OR 11-1901 and shall comply with the duties
11 imposed on the office pursuant to title 9, chapter 13 FOR COMPLAINTS
12 INVOLVING LOCAL GOVERNMENTS AND TITLE 11, CHAPTER 14 FOR COMPLAINTS
13 INVOLVING COUNTIES.

14 Sec. 10. Legislative findings

15 The legislature has determined that it is reasonable and necessary
16 to promote a matter of statewide concern by regulating the licensure and
17 provision of video service to promote all of the following:

18 1. Provision of competitive video, telecommunications and
19 information service throughout this state.

20 2. More uniform regulation of competitive video service throughout
21 the state.

22 3. Streamlined licensing by local governments and counties.

23 4. More uniform terms and conditions for video service providers
24 that use highways to provide video and other services over video service
25 networks.

26 5. Continued highway management by local governments and counties
27 with reasonable burdens on video service providers for construction and
28 maintenance across boundaries.

29 6. Continued levying of license fees by local governments and
30 counties on subscriber service revenues derived from operating video
31 service networks to provide video service.

32 7. Support for federal subscriber service standards.

APPROVED BY THE GOVERNOR APRIL 11, 2019.

FILED IN THE OFFICE OF THE SECRETARY OF STATE APRIL 11, 2019.

State of Arizona
House of Representatives
Fifty-fourth Legislature
First Regular Session
2019

CHAPTER 163
HOUSE BILL 2179

AN ACT

AMENDING SECTIONS 9-461.17, 9-584, 9-591, 11-1801, 13-1801, 13-3709, 13-3712, 16-911, 16-921, 18-502, 26-320, 40-283, 40-341, 40-354, 40-360.24, 40-360.41, 40-491, 41-1954, 42-5063, 42-5064, 42-5069 AND 42-5071, ARIZONA REVISED STATUTES; AMENDING SECTION 42-6004, ARIZONA REVISED STATUTES, AS AMENDED BY LAWS 2018, CHAPTER 17, SECTION 1, CHAPTER 249, SECTION 6 AND CHAPTER 341, SECTION 2; AMENDING SECTION 42-6004, ARIZONA REVISED STATUTES, AS AMENDED BY LAWS 2018, CHAPTER 17, SECTION 1, CHAPTER 249, SECTION 6, CHAPTER 263, SECTION 3 AND CHAPTER 341, SECTION 2; AMENDING SECTIONS 44-1273, 48-620, 48-5107 AND 48-5315, ARIZONA REVISED STATUTES; RELATING TO VIDEO SERVICE PROVIDERS.

(TEXT OF BILL BEGINS ON NEXT PAGE)

1 Be it enacted by the Legislature of the State of Arizona:

2 Section 1. Section 9-461.17, Arizona Revised Statutes, is amended
3 to read:

4 9-461.17. Telecommunications utility relocation: cost
5 reimbursement; definitions

6 A. To the fullest extent allowed by law, if any construction
7 project in any municipality that is undertaken individually or jointly by
8 an intergovernmental contract and that is funded in whole or in part by
9 voter-approved municipal bond proceeds requires that a telecommunications
10 utility adjust or otherwise relocate the telecommunications utility's
11 facilities, the municipality shall reimburse the telecommunications
12 utility, or cause the telecommunications utility to be reimbursed, for the
13 telecommunications utility's relocation costs incurred on facilities
14 located within the municipal boundaries.

15 B. If the telecommunications utility has existing land rights, the
16 municipality shall provide at the municipality's expense the
17 telecommunications utility with equal land rights in the new location of
18 the relocated facilities. If the telecommunications utility's existing
19 facilities are located in the right-of-way under a permit, the
20 municipality shall provide at the municipality's expense the
21 telecommunications utility with rights in the new location of the
22 relocated facilities equivalent to the telecommunications utility's
23 existing rights under the permit.

24 C. A telecommunications utility shall submit a verified itemized
25 claim to the municipality for reimbursement of relocation costs within one
26 hundred eighty days after each calendar quarter in which a
27 telecommunications utility incurs relocation costs.

28 D. The municipality shall:

29 1. Review each verified itemized claim submitted pursuant to
30 subsection C of this section. The review may include an audit conducted
31 pursuant to standard industry accounting principles.

32 2. Reimburse the telecommunications utility for the relocation
33 costs within ninety days after receipt of the verified itemized claim.

34 3. Reimburse verified itemized claims from all affected
35 telecommunications utilities in the order of receipt.

36 E. The reimbursement limitation for paid claims of relocation costs
37 for telecommunications utility facilities for which there are no existing
38 land rights is not more than two percent of the total project monies. The
39 total **OF THE** project monies is the total dollar amount of all
40 voter-approved **MUNICIPAL** bond proceeds that fund a construction project
41 from time to time.

42 F. The total amount of reimbursement paid for claims of relocation
43 costs of all telecommunications utility facilities for which there are no
44 existing land rights may not exceed the reimbursement limitation.

1 G. If a verified itemized claim causes the total amount of all
2 claims for telecommunications utility relocation costs to exceed the
3 reimbursement limitation, that claim shall be reduced so that the total
4 amount of reimbursement paid for all claims for which there are no
5 existing land rights equals the reimbursement limitation.

6 H. If the dollar amount of the reimbursement limitation increases
7 as a result of an increase in total project funds after the previous
8 reimbursement limitation is exhausted, within thirty days after the
9 reimbursement limitation is increased the municipality shall resume
10 processing previously submitted and new verified itemized claims under
11 this section.

12 I. The reimbursement limitation does not apply to any claims for
13 reimbursement of relocation costs for telecommunications utility
14 facilities with existing land rights or any amounts paid by the
15 municipality to provide equivalent land or permit rights. These claims
16 and amounts are excluded from the reimbursement limitation.

17 J. This section does not:

18 1. Apply to a construction project funded in whole or in part with
19 voter-approved municipal bond proceeds if approval of the bonds was
20 referred to the voters, or the initiative petition for the bonds was
21 applied for, before January 1, 2017.

22 2. Prohibit a municipality from complying with other applicable
23 law, or with an agreement, that requires the municipality to reimburse a
24 telecommunications utility for more relocation costs than this section
25 provides.

26 K. For the purposes of this section:

27 1. "Intergovernmental contract" means the joint exercise of powers
28 authorized by title 11, chapter 7, article 3.

29 2. "Municipality" includes a charter city.

30 3. "Relocation costs" means all costs of relocating a
31 telecommunications utility's facilities that the telecommunications
32 utility incurs as a direct result of the construction and operation of a
33 construction project. Relocation costs do not include profit but may
34 include a reasonable allocation of general overhead expenses.

35 4. "Telecommunications utility" means any public service
36 corporation, licensed cable ~~system~~ TELEVISION operator, VIDEO SERVICE
37 PROVIDER, telephone line or telegraph line corporation, agricultural
38 improvement district or other person engaged in the transmission, sale or
39 delivery of telecommunications, telephone, cable television, VIDEO,
40 internet or telegraph service directly to the public or to other users as
41 to be effectively available directly to the public.

1 Sec. 2. Section 9-584, Arizona Revised Statutes, is amended to
2 read:

3 9-584. Microcell equipment in public highways; permits; fees;
4 limitations; definitions

5 A. A political subdivision shall allow the following persons and
6 their affiliates to install, operate and maintain microcell equipment in
7 the public highways that are under the jurisdiction of the political
8 subdivision:

9 1. A telecommunications corporation within the licensed area of a
10 license issued by the political subdivision under this article.

11 2. A telecommunications corporation described in section 9-582,
12 subsection E.

13 3. A cable operator **AS DEFINED IN SECTION 9-505** in the area of
14 jurisdiction licensed by the political subdivision under section 9-506.

15 4. **A VIDEO SERVICE PROVIDER IN THE SERVICE AREA LICENSED BY THE**
16 **POLITICAL SUBDIVISION.**

17 B. On application a political subdivision shall issue permits for
18 the installation, operation and maintenance of microcell equipment in the
19 public highways within the political subdivision on a competitively
20 neutral and nondiscriminatory basis to all persons specified in subsection
21 A of this section. Only a qualified service provider may use microcell
22 equipment to provide commercial mobile radio service.

23 C. All application fees, permit fees and charges levied by a
24 political subdivision for applications or permits shall be levied on a
25 competitively neutral and nondiscriminatory basis and directly related to
26 the costs incurred by the political subdivision in providing services
27 relating to the granting or administration of applications or permits.
28 These fees and charges also shall be reasonably related in time to the
29 occurrence of the costs.

30 D. A political subdivision may not charge a recurring fee, rent or
31 other charge for use of aerial strand-mounted microcell equipment in
32 public highways within the political subdivision if the political
33 subdivision levies a rent, fee or charge on a person identified in
34 subsection A of this section for the use of the public highways to provide
35 a service. This subsection does not prohibit a political subdivision from
36 charging a competitively neutral and nondiscriminatory rent, fee or charge
37 for the use of utility poles or other poles of the political subdivision.

38 E. Except as the political subdivision agrees in the political
39 subdivision's sole discretion, at each site microcell equipment is limited
40 to:

41 1. Not more than two strand-mounted antennas and radio pairs that
42 are owned by a person specified in subsection A of this section or a
43 qualified service provider and that are used to provide commercial mobile
44 radio service.

1 2. Related devices that are owned by a person specified in
2 subsection A of this section and that are mounted on strand between
3 utility poles, including power supplies, housings, cables and similar
4 supporting furnishings and improvements.

5 F. This section does not:

6 1. Affect any authority of a political subdivision, an agricultural
7 improvement district or any other special taxing district, or any other
8 person controlling utility poles in the public highways to deny, limit,
9 restrict or determine the terms and conditions for use of or attachment to
10 the utility poles or attachments to other poles of the political
11 subdivision, district or other person by a person specified in subsection
12 A of this section.

13 2. Prohibit a political subdivision from imposing competitively
14 neutral and nondiscriminatory requirements for a person identified in
15 subsection A of this section to underground aerial facilities to which
16 microcell equipment is attached.

17 3. Prohibit a political subdivision from imposing a tax, rent, fee
18 or charge on revenue from services provided through microcell equipment.

19 4. Affect any authority of a political subdivision to manage the
20 public highways within the political subdivision's boundaries or to
21 exercise the political subdivision's police powers and land use powers,
22 including review and approval of an application before issuing a permit.

23 5. Affect the application of federal law on processing
24 applications, issuing permits and levying charges for the construction,
25 management, installation, operation, maintenance and control of microcell
26 equipment in the public highways.

27 G. For the purposes of this section:

28 1. "Affiliate" means a person that directly or indirectly, through
29 one or more intermediaries, controls, is controlled by or is under common
30 control with a person specified in subsection A of this section.

31 2. "Microcell equipment" means devices that are connected to the
32 aerial facilities of a person specified in subsection A of this section
33 and that are used solely for transmitting, processing and receiving voice
34 and data wireless telecommunications services. Microcell equipment does
35 not include any ground-based equipment.

36 3. Political subdivision does not include an agricultural
37 improvement district or other special taxing district that controls
38 utility poles or an irrigation district.

39 4. "Qualified service provider" means a person that has all
40 applicable authorizations required to provide commercial mobile radio
41 service using microcell equipment.

42 5. "Utility pole" means a pole or similar structure and attached
43 appurtenances including strand that is designed for telecommunications,
44 cable, data or electric functions.

1 Sec. 3. Section 9-591, Arizona Revised Statutes, is amended to
2 read:

3 9-591. Definitions

4 In this article, unless the context otherwise requires:

5 1. "Antenna" means communications equipment that transmits or
6 receives electromagnetic radio frequency signals and that is used in
7 providing wireless services.

8 2. "Applicable codes" means uniform building, fire, electrical,
9 plumbing or mechanical codes that are adopted by a recognized national
10 code organization or local amendments to those codes that are enacted to
11 address threats of destruction of property or injury to persons and to an
12 extent that is not inconsistent with this article.

13 3. "Applicant" means any person that submits an application and
14 that is a wireless provider.

15 4. "Application" means a request that is submitted by an applicant
16 to an authority for a permit to collocate small wireless facilities or to
17 approve the installation, modification or replacement of a utility pole or
18 wireless support structure.

19 5. "Authority" means any city, town, special district or political
20 subdivision of this state that is authorized to make legislative,
21 quasi-judicial or administrative decisions concerning an application.
22 Authority does not include any state court that has jurisdiction over an
23 authority and does not include a county, special taxing district, or
24 electric cooperative.

25 6. "Authority utility pole" means a utility pole that is owned or
26 operated by an authority and that is in a right-of-way. Authority utility
27 pole does not include a utility pole for electric distribution.

28 7. "Cable operator" has the same meaning prescribed in section
29 9-505 **AND INCLUDES A VIDEO SERVICE PROVIDER**. Cable operator does not
30 include a special taxing district.

31 8. "Collocate" or "collocation" means to install, mount, maintain,
32 modify, operate or replace wireless facilities on, within or adjacent to a
33 wireless support structure or utility pole.

34 9. "Communications service" means cable service as defined in
35 47 United States Code section 522(6), information service as defined in
36 47 United States Code section 153(24), telecommunications service as
37 defined in 47 United States Code section 153(53) or wireless service.

38 10. "Communications service provider" means a cable operator, a
39 provider of information service as defined in 47 United States Code
40 section 153(24), a telecommunications carrier as defined in 47 United
41 States Code section 153(51) or a wireless services provider.

42 11. "Fee" means a onetime charge.

43 12. "Law" means any federal, state or local law, statute, common
44 law, code, rule, regulation, order or ordinance.

1 13. "Monopole" means a wireless support structure that is not more
2 than forty inches in diameter at the ground level and that has all of the
3 wireless facilities mounted on the pole or contained inside of the pole.

4 14. "Permit" means written permission required by an authority to
5 install, mount, maintain, modify, operate or replace a utility pole or
6 monopole, to collocate a small wireless facility on a utility pole or
7 wireless support structure or to collocate wireless facilities on a
8 monopole.

9 15. "Person" means an individual, corporation, limited liability
10 company, partnership, association, trust or other entity or organization,
11 including an authority.

12 16. "Private easement" means an easement or other real property
13 right that is only for the benefit of the grantor and grantee and the
14 grantor's or grantee's successors and assigns.

15 17. "Rate" means a recurring charge.

16 18. "Right-of-way" means the area on, below or above a public
17 roadway, highway, street, sidewalk, alley or utility easement.
18 Right-of-way does not include a federal interstate highway, a state
19 highway or state route under the jurisdiction of the department of
20 transportation, a private easement, property that is owned by a special
21 taxing district, or a utility easement that does not authorize the
22 deployment sought by the wireless provider.

23 19. "Small wireless facility" means a wireless facility that meets
24 both of the following qualifications:

25 (a) All antennas are located inside an enclosure of not more than
26 six cubic feet in volume or, in the case of an antenna that has exposed
27 elements, the antenna and all of the antenna's exposed elements could fit
28 within an imaginary enclosure of not more than six cubic feet in volume.

29 (b) All other wireless equipment associated with the facility is
30 cumulatively not more than twenty-eight cubic feet in volume, or fifty
31 cubic feet in volume if the equipment was ground mounted before August 9,
32 2017. The following types of associated ancillary equipment are not
33 included in the calculation of equipment volume pursuant to this
34 subdivision:

35 (i) An electric meter.

36 (ii) Concealment elements.

37 (iii) A telecommunications demarcation box.

38 (iv) Grounding equipment.

39 (v) A power transfer switch.

40 (vi) A cutoff switch.

41 (vii) Vertical cable runs for the connection of power and other
42 services.

1 20. "Special taxing district" means a special district formed
2 pursuant to title 48, chapter 11, 12, 17, 18, 19, 20 or 22.

3 21. "Utility pole" means a pole or similar structure that is used
4 in whole or in part for communications services, electric distribution,
5 lighting or traffic signals. Utility pole does not include a monopole.

6 22. "Wireless facility":

7 (a) Means equipment at a fixed location that enables wireless
8 communications between user equipment and a communications network,
9 including both of the following:

10 (i) Equipment associated with wireless communications.

11 (ii) Radio transceivers, antennas, coaxial or fiber-optic cables,
12 regular and backup power supplies and comparable equipment, regardless of
13 technological configuration.

14 (b) Includes small wireless facilities.

15 (c) Does not include the structure or improvements on, under or
16 within which the equipment is collocated, wireline backhaul facilities,
17 coaxial or fiber-optic cable that is between wireless support structures
18 or utility poles or coaxial or fiber-optic cable that is otherwise not
19 immediately adjacent to, or directly associated with, an antenna.

20 (d) Does not include Wi-Fi radio equipment described in section
21 9-506, subsection I or microcell equipment described in section 9-584,
22 subsection E.

23 23. "Wireless infrastructure provider" means any person that is
24 authorized to provide telecommunications service in this state and that
25 builds or installs wireless communications transmission equipment,
26 wireless facilities, utility poles or monopoles but that is not a wireless
27 services provider. Wireless infrastructure provider does not include a
28 special taxing district.

29 24. "Wireless provider" means a cable operator, wireless
30 infrastructure provider or wireless services provider.

31 25. "Wireless services" means any services that are provided to the
32 public and that use licensed or unlicensed spectrum, whether at a fixed
33 location or mobile, using wireless facilities.

34 26. "Wireless services provider" means a person that provides
35 wireless services. Wireless services provider does not include a special
36 taxing district.

37 27. "Wireless support structure":

38 (a) Means:

39 (i) A freestanding structure, such as a monopole.

40 (ii) A tower, either guyed or self-supporting.

41 (iii) A sign or billboard.

42 (iv) Any other existing or proposed structure designed to support
43 or capable of supporting small wireless facilities.

44 (b) Does not include a utility pole.

1 Sec. 4. Section 11-1801, Arizona Revised Statutes, is amended to
2 read:

3 11-1801. Definitions

4 In this article, unless the context otherwise requires:

5 1. "Antenna" means communications equipment that transmits or
6 receives electromagnetic radio frequency signals and that is used in
7 providing wireless services.

8 2. "Applicable codes" means uniform building, fire, electrical,
9 plumbing or mechanical codes that are adopted by a recognized national
10 code organization or local amendments to those codes that are enacted to
11 address threats of destruction of property or injury to persons and to an
12 extent that is not inconsistent with this article.

13 3. "Applicant" means any person that submits an application and
14 that is a wireless provider.

15 4. "Application" means a request that is submitted by an applicant
16 to a county on a form provided by the county for a permit to collocate
17 small wireless facilities or to approve the installation, modification or
18 replacement of a utility pole.

19 5. "Cable operator" has the same meaning prescribed in section
20 9-505 **AND INCLUDES A VIDEO SERVICE PROVIDER**. Cable operator does not
21 include a special taxing district.

22 6. "Collocate" or "collocation" means to install, mount, maintain,
23 modify, operate or replace wireless facilities on, within or adjacent to a
24 wireless support structure or utility pole.

25 7. "Communications service" means cable service as defined in
26 47 United States Code section 522(6), information service as defined in
27 47 United States Code section 153(24), telecommunications service as
28 defined in 47 United States Code section 153(53) or wireless service.

29 8. "Communications service provider" means a cable operator, a
30 provider of information service as defined in 47 United States Code
31 section 153(24), a telecommunications carrier as defined in 47 United
32 States Code section 153(51) or a wireless services provider.

33 9. "County utility pole" means a utility pole that is owned or
34 operated by a county and that is in a right-of-way.

35 10. "Fee" means a onetime charge to process an application and
36 inspect any work performed by an applicant pursuant to a permit issued by
37 the county.

38 11. "Law" means any federal, state or local law, statute, common
39 law, code, rule, regulation, order or ordinance.

40 12. "Permit" means written permission issued by a county to
41 install, mount, maintain, modify, operate or replace a utility pole or to
42 collocate a small wireless facility on a utility pole or wireless support
43 structure.

1 13. "Person" means an individual, corporation, limited liability
2 company, partnership, association, trust or other entity or organization,
3 including a county.

4 14. "Private easement" means an easement or other real property
5 right that is only for the benefit of the grantor and grantee and the
6 grantor's or grantee's successors and assigns.

7 15. "Rate" means a onetime charge for the granting of a right to
8 use a portion of a right-of-way as specified in a permit or to collocate a
9 small wireless facility on or adjacent to a utility pole or to install,
10 modify or replace a utility pole as specified in a permit.

11 16. "Right-of-way" means the area on, below or above a county
12 roadway, highway, street, sidewalk, alley or utility easement.
13 Right-of-way does not include a federal interstate highway, a state
14 highway or state route under the jurisdiction of the department of
15 transportation, a private easement, property that is owned by a special
16 taxing district, or a utility easement that does not authorize the
17 deployment sought by the wireless provider.

18 17. "Small wireless facility" means a wireless facility that meets
19 both of the following qualifications:

20 (a) All antennas are located inside an enclosure of not more than
21 six cubic feet in volume or, in the case of an antenna that has exposed
22 elements, the antenna and all of the antenna's exposed elements could fit
23 within an imaginary enclosure of not more than six cubic feet in volume.

24 (b) All other wireless equipment associated with the facility is
25 cumulatively not more than twenty-eight cubic feet in volume, or fifty
26 cubic feet in volume if the equipment was ground mounted before August 9,
27 2017. The following types of associated ancillary equipment are not
28 included in the calculation of equipment volume pursuant to this
29 subdivision:

30 (i) An electric meter.

31 (ii) Concealment elements.

32 (iii) A telecommunications demarcation box.

33 (iv) Grounding equipment.

34 (v) A power transfer switch.

35 (vi) A cutoff switch.

36 (vii) Vertical cable runs for the connection of power and other
37 services.

38 18. "Special taxing district" means a special district formed
39 pursuant to title 48, chapter 11, 12, 17, 18, 19, 20 or 22.

40 19. "Utility pole" means a pole or similar structure that is used
41 in whole or in part for communications services, electric distribution,
42 lighting or traffic signals or a similar function.

43 20. "Wireless facility":

1 (a) Means equipment at a fixed location that enables wireless
2 communications between user equipment and a communications network,
3 including both of the following:

4 (i) Equipment associated with wireless communications.

5 (ii) Radio transceivers, antennas, coaxial or fiber-optic cables,
6 regular and backup power supplies and comparable equipment, regardless of
7 technological configuration.

8 (b) Includes small wireless facilities.

9 (c) Does not include the structure or improvements on, under or
10 within which the equipment is collocated, wireline backhaul facilities,
11 coaxial or fiber-optic cable that is between wireless support structures
12 or utility poles or coaxial or fiber-optic cable that is otherwise not
13 immediately adjacent to, or directly associated with, an antenna.

14 (d) Does not include Wi-Fi radio equipment described in section
15 9-506, subsection I or microcell equipment described in section 9-584,
16 subsection E.

17 21. "Wireless infrastructure provider" means any person that is
18 authorized to provide telecommunications service in this state and that
19 builds or installs wireless communications transmission equipment,
20 wireless facilities or utility poles but that is not a wireless services
21 provider. Wireless infrastructure provider does not include a special
22 taxing district.

23 22. "Wireless provider" means a cable operator, wireless
24 infrastructure provider or wireless services provider.

25 23. "Wireless services" means any services that are provided to the
26 public and that use licensed or unlicensed spectrum, whether at a fixed
27 location or mobile, using wireless facilities.

28 24. "Wireless services provider" means a person that provides
29 wireless services. Wireless services provider does not include a special
30 taxing district.

31 25. "Wireless support structure":

32 (a) Means:

33 (i) A freestanding structure.

34 (ii) A tower, either guyed or self-supporting.

35 (iii) Any other existing or proposed structure designed to support
36 or capable of supporting small wireless facilities.

37 (b) Does not include a utility pole.

38 Sec. 5. Section 13-1801, Arizona Revised Statutes, is amended to
39 read:

40 13-1801. Definitions

41 A. In this chapter, unless the context otherwise requires:

42 1. "Check" means any check, draft or other negotiable or
43 nonnegotiable instrument of any kind.

- 1 2. "Control" or "exercise control" means to act so as to exclude
2 others from using their property except on the defendant's own terms.
- 3 3. "Credit" means an express agreement with the drawee for the
4 payment of a check.
- 5 4. "Deprive" means to withhold the property interest of another
6 either permanently or for so long a time period that a substantial portion
7 of its economic value or usefulness or enjoyment is lost, to withhold with
8 the intent to restore it only on payment of any reward or other
9 compensation or to transfer or dispose of it so that it is unlikely to be
10 recovered.
- 11 5. "Draw" means making, drawing, uttering, preparing, writing or
12 delivering a check.
- 13 6. "Funds" means money or credit.
- 14 7. "Issue" means to deliver or cause to be delivered a check to a
15 person who thereby acquires a right against the drawer with respect to the
16 check. A person who draws a check with the intent that it be so delivered
17 is deemed to have issued it if the delivery occurs.
- 18 8. "Material misrepresentation" means a pretense, promise,
19 representation or statement of present, past or future fact that is
20 fraudulent and that, when used or communicated, is instrumental in causing
21 the wrongful control or transfer of property or services. The pretense
22 may be verbal or it may be a physical act.
- 23 9. "Means of transportation" means any vehicle.
- 24 10. "Obtain" means to bring about or to receive the transfer of any
25 interest in property, whether to a defendant or to another, or to secure
26 the performance of a service or the possession of a trade secret.
- 27 11. "Pass" means, for a payee, holder or bearer of a check that
28 previously has been or purports to have been drawn and issued by another,
29 to deliver a check, for a purpose other than collection, to a third person
30 who by delivery acquires a right with respect to the check.
- 31 12. "Property" means any thing of value, tangible or intangible,
32 including trade secrets.
- 33 13. "Property of another" means property in which any person other
34 than the defendant has an interest on which the defendant is not
35 privileged to infringe, including property in which the defendant also has
36 an interest, notwithstanding the fact that the other person might be
37 precluded from civil recovery because the property was used in an unlawful
38 transaction or was subject to forfeiture as contraband. Property in
39 possession of the defendant is not deemed property of another person who
40 has only a security interest in the property, even if legal title is in
41 the creditor pursuant to a security agreement.
- 42 14. "Services" includes labor, professional services,
43 transportation, cable ~~television~~ SERVICE AND VIDEO SERVICE, computer or
44 communication services, gas or electricity services, accommodation in

1 hotels, restaurants or leased premises or elsewhere, admission to
2 exhibitions and use of vehicles or other movable property.

3 15. "Value" means the fair market value of the property or services
4 at the time of the theft. The value of ferrous metal, **AS DEFINED IN**
5 **SECTION 44-1641**, or nonferrous metal, ~~as defined in section 44-1641~~, is
6 the average fair market value of the metal in the local area together with
7 the repair or replacement value of any property from which the metal was
8 removed at the time of the theft. Written instruments that do not have a
9 readily ascertained market value have as their value either the face
10 amount of indebtedness less the portion satisfied or the amount of
11 economic loss involved in deprivation of the instrument, whichever is
12 greater. When property has an undeterminable value the trier of fact
13 shall determine its value and, in reaching its decision, may consider all
14 relevant evidence, including evidence of the property's value to its
15 owner.

16 B. In determining the classification of the offense, the state may
17 aggregate in the indictment or information amounts taken in thefts
18 committed pursuant to one scheme or course of conduct, whether the amounts
19 were taken from one or several persons.

20 Sec. 6. Section 13-3709, Arizona Revised Statutes, is amended to
21 read:

22 13-3709. Obtaining cable television and video services
23 fraudulently; manufacturing, distributing and
24 selling unauthorized decoding devices;
25 classification; definition

26 A. Any person who with the intent to defraud another of any part of
27 the lawful charge for services that are provided over or by a licensed
28 cable television system as defined in section 9-505, ~~OR A LICENSED VIDEO~~
29 **SERVICE NETWORK** makes any unauthorized connection, whether physically,
30 electrically, acoustically, inductively or otherwise, or attaches any
31 unauthorized device or devices to any cable, wire, microwave or other
32 component of a licensed cable television system **OR LICENSED VIDEO SERVICE**
33 **NETWORK**, to a television set or to any other instrument that is authorized
34 to be attached to a **LICENSED** cable television system **OR LICENSED VIDEO**
35 **SERVICE NETWORK** is guilty of a class 2 misdemeanor.

36 B. Any person who manufactures, distributes, sells, rents, lends,
37 offers or advertises for sale, rental or use any device that the person
38 intends to be used by another person to obtain services that are provided
39 over or by a licensed cable television system **OR A LICENSED VIDEO SERVICE**
40 **NETWORK** without payment of the charge for those services is guilty of a
41 class 6 felony.

42 C. For the purposes of subsection B of this section it is a
43 rebuttable presumption that the person intended that the device would be
44 used by another person to obtain services that are provided over or by a
45 licensed cable television system **OR A LICENSED VIDEO SERVICE NETWORK**

1 without payment of the charge for those services if, while advertising,
2 selling, renting or lending the device, the person states that the device
3 will enable the person who receives the device to obtain cable television,
4 VIDEO or other services without payment of the charge for those services.

5 D. For the purposes of subsection B of this section, it is a
6 separate violation for each individual device that is manufactured,
7 distributed, sold, rented, lent, offered or advertised for sale, rental or
8 use in violation of subsection B of this section.

9 E. A person whose business or property is injured arising out of a
10 violation of this section may bring an action in superior court to recover
11 damages or for an injunction, or both. The successful party to the action
12 may recover reasonable attorney fees.

13 F. ~~As used in~~ FOR THE PURPOSES OF this section, "device" includes
14 any component or combination of components capable of converting a
15 scrambled, ENCRYPTED or ~~coded~~ ENCODED cable television OR VIDEO SERVICE
16 signal to a signal usable on a standard television receiver.

17 Sec. 7. Section 13-3712, Arizona Revised Statutes, is amended to
18 read:

19 13-3712. Interruption of or injury to cable television and
20 video systems; classification

21 Any person who, without the consent of the owner, knowingly tampers
22 with, removes or injures any cable, wire, microwave or other component of
23 a licensed cable television system as defined in section 9-505 OR LICENSED
24 VIDEO SERVICE NETWORK or knowingly interrupts the service of ~~such a~~ THE
25 licensed cable television system OR LICENSED VIDEO SERVICE NETWORK without
26 the consent of the owner is guilty of a class 2 misdemeanor.

27 Sec. 8. Section 16-911, Arizona Revised Statutes, is amended to
28 read:

29 16-911. Exemption from definition of contribution

30 A. A person may make any contribution not otherwise prohibited by
31 law.

32 B. The following are not contributions:

33 1. The value of an individual's volunteer services or expenses that
34 are provided without compensation or reimbursement, including the
35 individual's:

36 (a) Travel expenses.

37 (b) Use of real or personal property.

38 (c) Cost of invitations, food or beverages.

39 (d) Use of e-mail, internet activity or social media messages, only
40 if the individual's use is not paid for by the individual or any other
41 person and if the e-mails, social media messages or other internet
42 activities do not contain or include transmittal of a paid advertisement
43 or paid fund-raising solicitation.

1 2. The costs incurred for covering or carrying a news story,
2 commentary or editorial by a broadcasting station or cable television
3 operator, VIDEO SERVICE PROVIDER, an internet website, a newspaper or
4 another periodical publication, including an internet-based or electronic
5 publication, if the cost for the news story, commentary or editorial is
6 not paid for by and the medium is not owned or under the control of a
7 candidate or committee.

8 3. Any payment to defray the expense of an elected official meeting
9 with constituents or attending an informational tour, conference, seminar
10 or presentation, if the payor or the elected official does not attempt to
11 influence the result of an election and the payment is reported if
12 required pursuant to title 38, chapter 3.1 or title 41, chapter 7, article
13 8.1, or both.

14 4. The payment by a political party to support its nominee,
15 including:

16 (a) The printing or distribution of, or postage expenses for, voter
17 guides, sample ballots, pins, bumper stickers, handbills, brochures,
18 posters, yard signs and other similar materials distributed through the
19 party.

20 (b) Coordinated ~~political~~ party expenditures.

21 5. The payment by any person to defray a political party's
22 operating expenses or party-building activities, including:

23 (a) Party staff and personnel.

24 (b) Studies and reports.

25 (c) Voter registration, recruitment, polling and turnout efforts.

26 (d) Party conventions and party meetings.

27 (e) Construction, purchase or lease of party buildings or
28 facilities.

29 6. The value of any of the following to a committee:

30 (a) Interest earned on the committee's deposits or investments.

31 (b) Transfers between committees to reimburse expenses and
32 distribute monies raised through a joint fund-raising effort, if the
33 transfers comply with an agreement to reimburse and distribute monies that
34 was executed before the joint fund-raising effort occurred.

35 (c) Payment of a committee's legal or accounting expenses by any
36 person.

37 (d) An extension of credit for goods and services on a committee's
38 behalf by a creditor if the terms are substantially similar to extensions
39 of credit to nonpolitical debtors that are of similar risk and size of
40 obligation. The creditor must make a commercially reasonable attempt to
41 collect the debt, except that if an extension of credit remains
42 unsatisfied by the committee after six months the committee is deemed to
43 have received a contribution but the creditor is not deemed to have made a
44 contribution.

1 7. The value of nonpartisan communications that are intended to
2 encourage voter registration and turnout efforts.

3 8. Any payment to a filing officer for arguments in a publicity
4 pamphlet.

5 9. The payment by any sponsor or its affiliate for the costs of
6 establishing, administering and soliciting contributions from its
7 employees, members, executives, stockholders and retirees and their
8 families to the sponsor's separate segregated fund.

9 10. Any payment by any entity for the costs of communicating with
10 its employees, members, executives, stockholders and retirees and their
11 families about any subject, without regard to whether those communications
12 are made in coordination with any candidate or candidate's agent.

13 11. The value of allowing a candidate or a committee's
14 representative to appear at any private residence or at the facilities of
15 any entity to speak about the candidate's campaign or about a ballot
16 measure, if the venue is furnished by the venue's owner, is not paid for
17 by a third party and is not a sports stadium, coliseum, convention center,
18 hotel ballroom, concert hall or other similar arena that is generally open
19 to the public.

20 12. The costs of hosting a debate or candidates' forum, if at least
21 two opposing candidates, with respect to any given office sought, or
22 representatives of at least two opposing ballot measure campaigns, with
23 respect to any measure on the ballot, are invited with the same or similar
24 advance notice and method of invitation.

25 13. The preparation and distribution of voter guides, subject to
26 the following:

27 (a) A featured candidate or ballot measure shall not receive
28 greater prominence or substantially more space in the voter guide than any
29 other candidate or ballot measure.

30 (b) The voter guide shall not include any message that constitutes
31 express advocacy.

32 14. Monies that are loaned by a financial institution in the
33 ordinary course of business and not for the purpose of influencing the
34 results of an election, except that the loan is deemed a pro rata
35 contribution by any endorser or guarantor, other than the candidate's
36 spouse.

37 15. The costs of publishing a book or producing a documentary, if
38 the publication and production are for distribution to the general public
39 through traditional distribution mechanisms or a fee is obtained for the
40 purchase of the publication or viewing of the documentary.

41 C. This section does not imply that any transactions that are not
42 specifically listed in subsection B of this section are contributions
43 unless those transactions otherwise meet the definition of contribution as
44 defined in section 16-901.

1 Sec. 9. Section 16-921, Arizona Revised Statutes, is amended to
2 read:
3 16-921. Exemptions from definition of expenditure
4 A. A person may make any expenditure not otherwise prohibited by
5 law.
6 B. The following are not expenditures:
7 1. The value of an individual's volunteer services or expenses that
8 are provided without compensation or reimbursement, including the
9 individual's:
10 (a) Travel expenses.
11 (b) Use of real or personal property.
12 (c) Cost of invitations, food or beverages.
13 (d) Use of e-mail, internet activity or social media messages, only
14 if the individual's use is not paid for by the individual or any other
15 person and if the e-mails, social media messages or other internet
16 activities do not contain or include transmittal of a paid advertisement
17 or paid fund-raising solicitation.
18 2. The value of any news story, commentary or editorial by any
19 broadcasting station, cable television operator, VIDEO SERVICE PROVIDER,
20 programmer or producer, newspaper, magazine, website or other periodical
21 publication that is not owned or operated by a candidate, a candidate's
22 spouse or any committee.
23 3. The payment by any person to defray a political party's
24 operating expenses or party-building activities, including:
25 (a) Party staff and personnel.
26 (b) Studies and reports.
27 (c) Voter registration, recruitment, polling and turnout efforts.
28 (d) Party conventions and party meetings.
29 (e) Construction, purchase or lease of party buildings or
30 facilities.
31 4. The value of any of the following to a committee:
32 (a) Interest earned on the committee's deposits or investments.
33 (b) Transfers between committees to reimburse expenses and
34 distribute monies raised through a joint fund-raising effort, except that
35 contributions shall be allocated as described in the fund-raising
36 solicitation and expenses shall be allocated in the same proportion as
37 contributions.
38 (c) Payment of a committee's legal or accounting expenses.
39 (d) An extension of credit for goods and services on a committee's
40 behalf by a creditor if the terms are substantially similar to extensions
41 of credit to nonpolitical debtors that are of similar risk and size of
42 obligation. The creditor must make a commercially reasonable attempt to
43 collect the debt, except that if an extension of credit remains
44 unsatisfied by the committee after six months the committee is deemed to

1 have received a contribution but the creditor is not deemed to have made a
2 contribution.

3 5. The value of nonpartisan communications that are intended to
4 encourage voter registration and turnout efforts.

5 6. Any payment by a person that is not a committee to a filing
6 officer for arguments in a publicity pamphlet.

7 7. Any payment for legal or accounting services that are provided
8 to a committee.

9 8. The payment of costs of publishing a book or producing a
10 documentary, if the publication and production are for distribution to the
11 general public through traditional distribution mechanisms or a fee is
12 obtained for the purchase of the publication or viewing of the
13 documentary.

14 C. This section does not imply that any transactions that are not
15 specifically listed in subsection B of this section are expenditures
16 unless those transactions otherwise meet the definition of expenditure as
17 defined in section 16-901.

18 Sec. 10. Section 18-502, Arizona Revised Statutes, is amended to
19 read:

20 18-502. Prohibited activities; applicability

21 A. It is unlawful for any person who is not an owner or operator of
22 a computer to transmit computer software to a computer, with actual
23 knowledge or with conscious avoidance of actual knowledge, and to use the
24 software to do any of the following:

25 1. Modify, through intentionally deceptive means, settings that
26 control any of the following:

27 (a) The page that appears when an owner or operator of a computer
28 launches an internet browser or similar computer software used to access
29 and navigate the internet.

30 (b) The default provider or web proxy that an owner or operator of
31 a computer uses to access or search the internet.

32 (c) An owner's or operator's list of bookmarks used to access web
33 pages.

34 2. Collect, through intentionally deceptive means, personally
35 identifiable information:

36 (a) Through the use of a keystroke logging function that records
37 all keystrokes made by an authorized user who uses the computer and
38 transfers that information from the computer to another person.

39 (b) In a manner that correlates the information with data
40 respecting all or substantially all of the websites visited by an owner or
41 operator of the computer, other than websites operated by the person
42 collecting the information.

43 (c) With respect only to information described in section 18-501,
44 paragraph 9, by extracting such information from the hard drive of an
45 owner's or operator's computer.

1 3. Prevent, through intentionally deceptive means, an owner's or
2 operator's reasonable efforts to block the installation or execution of,
3 or to disable, computer software by causing software that an owner or
4 operator of the computer has properly removed or disabled automatically to
5 reinstall or reactivate on the computer.

6 4. Intentionally misrepresent that computer software will be
7 uninstalled or disabled by an owner's or operator's action.

8 5. Through intentionally deceptive means, remove, disable or render
9 inoperative security, antispyware or antivirus computer software installed
10 on the computer.

11 6. Take control of the computer by:

12 (a) Accessing or using the modem or internet service for the
13 computer for the purpose of causing damage to the computer or causing an
14 owner or operator to incur financial charges for a service that the owner
15 or operator of the computer has not authorized.

16 (b) Opening multiple, sequential, stand-alone advertisements in an
17 owner's or operator's internet browser without the authorization of the
18 owner or operator that a reasonable computer user cannot close without
19 turning off the computer or closing the internet browser.

20 7. Modify any of the following settings related to the computer's
21 access to, or use of, the internet:

22 (a) Settings that protect information about an owner or operator of
23 the computer for the purpose of stealing personally identifiable
24 information of the owner or operator.

25 (b) Security settings for the purpose of causing damage to a
26 computer.

27 8. Prevent an owner's or operator's reasonable efforts to block the
28 installation of, or to disable, computer software, by doing either of the
29 following:

30 (a) Presenting the owner or operator with an option to decline
31 installation of computer software with knowledge that, if the option is
32 selected, the installation nevertheless proceeds.

33 (b) Falsely representing that computer software has been disabled.

34 B. It is unlawful for any person who is not an owner or operator of
35 a computer to do either of the following with regard to the computer:

36 1. Induce an owner or operator to install a computer software
37 component on the computer by intentionally misrepresenting the extent to
38 which installing the software is necessary for security or privacy reasons
39 or in order to open, view or play a particular type of content.

40 2. Deceptively cause the execution on the computer of a computer
41 software component with the intent of causing an owner or operator to use
42 the component in a manner that violates any other provision of this
43 section.

44 C. This section does not apply to any monitoring of, or interaction
45 with, a subscriber's internet or other network connection or service, or a

1 computer, by a telecommunications carrier, cable operator, VIDEO SERVICE
2 PROVIDER, computer hardware or software provider or provider of
3 information service or interactive computer service for network or
4 computer security purposes, diagnostics, technical support, maintenance,
5 repair, authorized updates of software or system firmware, authorized
6 remote system management or detection or prevention of the unauthorized
7 use of or fraudulent or other illegal activities in connection with a
8 network, service or computer software, including scanning for and removing
9 software prescribed under this article.

10 Sec. 11. Section 26-320, Arizona Revised Statutes, is amended to
11 read:

12 26-320. First informer broadcasters; training and
13 certification; access; definitions

14 A. The division may coordinate with a broadcasting association in
15 this state or a cable television telecommunication association in this
16 state, or both, to develop comprehensive, coordinated plans for preparing
17 for and responding appropriately to an emergency or disaster.

18 B. The division may designate and authorize a statewide
19 organization that represents broadcasters, cable television communications
20 or any other provider that uses emerging technologies or a federally
21 licensed radio or television station to establish and conduct a program
22 approved by the division to train and certify broadcast engineers and
23 technical personnel that are critical to station operations as first
24 informer broadcasters. Training and certification pursuant to this
25 subsection shall:

26 1. Be consistent with federal law and guidelines.

27 2. Include education in restoring, repairing and resupplying any
28 facilities or equipment of a broadcaster in an area affected by an
29 emergency or disaster.

30 3. Include education concerning the personal safety of a first
31 informer broadcaster in an area affected by an emergency or disaster.

32 C. To the extent practicable and consistent with not endangering
33 public safety or inhibiting recovery efforts, state and local government
34 agencies shall allow a first informer broadcaster to access an area
35 affected by an emergency or disaster to restore, repair or resupply any
36 facility or equipment critical to the ability of a broadcaster to acquire,
37 produce and transmit essential emergency or disaster related public
38 information programming, including repairing and maintaining transmitters
39 and generators and transporting fuel for generators.

40 D. For the purposes of this section:

41 1. "Broadcaster" means a radio broadcasting station, cable
42 TELEVISION operator, VIDEO SERVICE PROVIDER or television broadcasting
43 station primarily engaged in, and deriving income from, the business of
44 facilitating speech via over-the-air communications, both as to pure
45 speech and commercial speech.

1 2. "First informer broadcaster" means a person who is trained and
2 certified as a first informer broadcaster pursuant to this section.

3 Sec. 12. Section 40-283, Arizona Revised Statutes, is amended to
4 read:

5 40-283. Transmission lines; use of public streets for utility
6 right-of-way; notice; election

7 A. Any person engaged in transportation or transmission business
8 within the state may construct and operate lines connecting any points
9 within the state and connect at the state boundary with like lines, except
10 that within the confines of municipal corporations the use and occupancy
11 of streets shall be under rights acquired by franchises according to law
12 or licenses pursuant to title 9, chapter 5, articles 1.1 and 4, and
13 subject to control and regulation by the municipal authorities. The use
14 of highways, except state highways, by public utilities not within any
15 incorporated city or town shall be regulated by the board of supervisors
16 of the county by license or franchise.

17 B. A board of supervisors in granting a license or franchise, or at
18 any time after it is granted, may impose restrictions and limitations upon
19 the use of the public roads as it deems best for the public safety or
20 welfare.

21 C. Every franchise granted under this article shall include
22 provisions requiring the grantee to bear all expenses, including damage
23 and compensation for any alteration of the direction, surface, grade or
24 alignment of a county road, made for the purpose of such franchise. If
25 the surface of a county highway is used by any grantee for trackage, the
26 franchise shall include reasonable regulations for maintenance by the
27 grantee of that portion of the highway so used.

28 D. A board of supervisors may authorize public service
29 corporations, telecommunications corporations, ~~or cable television systems~~
30 OPERATORS OR VIDEO SERVICE PROVIDERS to construct a line, plant, service
31 or system within the right-of-way of any road, highway or easement that is
32 designated for access or public use by plat or survey of record of a
33 subdivision, or of unsubdivided land as defined in section 32-2101,
34 provided that any such authorization or construction pursuant to such
35 authorization does not impose on the county the duty of maintaining the
36 road or highway unless the county accepts the road or highway into the
37 county maintenance system by appropriate resolution. ~~Nothing contained in~~
38 This subsection ~~shall be construed to~~ DOES NOT grant county boards of
39 supervisors additional authority to require public service corporations,
40 telecommunications corporations, ~~or cable television systems~~ OPERATORS OR
41 VIDEO SERVICE PROVIDERS to obtain licenses or franchises.

42 E. A board of supervisors, before granting any of the privileges
43 authorized under this section, shall give public notice of its intention
44 to ~~make such~~ grant SUCH PRIVILEGES by publishing notice in a newspaper of
45 general circulation, published within the county, at least once a week for

1 three weeks ~~prior to~~ BEFORE the day set for consideration of such action.
2 If, on or before such date, more than fifty ~~per cent~~ PERCENT of the
3 qualified electors of the county petition the board of supervisors to deny
4 ~~such~~ THE privilege, it shall do so, and any privilege granted against ~~such~~
5 THE petition ~~shall be~~ IS void.

6 Sec. 13. Section 40-341, Arizona Revised Statutes, is amended to
7 read:

8 40-341. Definitions

9 In this article, unless the context otherwise requires:

10 1. "Clerk" means the clerk of the board of supervisors or any
11 person or officer who acts as clerk of the board of supervisors.

12 2. "Convert" or "conversion" means the removal of existing overhead
13 electric or communication facilities and the replacement thereof with
14 underground electric or communication facilities constructed at the same
15 or different locations.

16 3. "Electric or communication facilities" means any works or
17 improvements used or useful in providing electric, communication or cable
18 television service OR VIDEO SERVICE, including ~~but not limited to~~ poles,
19 supports, tunnels, manholes, vaults, conduits, pipes, wires, conductors,
20 guys, stubs, platforms, crossarms, braces, transformers, insulators,
21 cutouts, switches, capacitors, meters, communication circuits, appliances,
22 attachments and appurtenances. ~~"Electric facilities" shall~~ DOES not
23 include any facilities used or intended to be used for the transmission of
24 electric energy at nominal voltages in excess of twenty-five thousand
25 volts or having a circuit capacity in excess of twelve thousand
26 kva. ~~"Communication facilities" shall~~ DOES not include facilities used
27 or intended to be used for the transmission of intelligence by microwave
28 or radio, apparatus cabinets or outdoor public telephones.

29 4. "Local government" means the city or town council if all or any
30 part of the underground conversion service area is located within the
31 limits of an incorporated city or town or the county board of supervisors
32 if the underground conversion service area is located in an unincorporated
33 area.

34 5. "Lot" includes any portion, piece, parcel or subdivision of
35 land, but not property owned or controlled by any person as a right of
36 way.

37 6. "Owner" means the person in whom legal title appears by recorded
38 deed, or the person in possession under claim of title, or the person
39 exercising acts of ownership for ~~himself~~ THE PERSON or as the personal
40 representative of the owner, including the boards of trustees of school
41 districts and the boards of education of high school districts owning
42 property within the underground conversion service area.

43 7. "Overhead electric or communication facilities" means electric
44 or communication facilities located above the surface of the ground,
45 except as provided for in paragraphs 3 and 12 of this section.

1 8. "Public agency" means any irrigation, power, electrical or
2 agricultural improvement district now or hereafter organized that provides
3 electric or communication service to the public by means of electric or
4 communication facilities.

5 9. "Public place" includes streets, alleys, roadways, sidewalks,
6 rights of way, easements and similar properties as to which a city, town,
7 county, the state, the public service corporation or the public agency may
8 have a right.

9 10. "Public service corporation" means any person or corporation
10 that provides electric or communication service to the public by means of
11 electric or communication facilities.

12 11. "Real property" means the real estate owned in fee, but not
13 inclusive of buildings or structures located thereon, or any property
14 owned or controlled as a railroad or street ~~right of way~~ RIGHT-OF-WAY.

15 12. "Underground conversion service area" means an area in which
16 existing electric and communication facilities are to be placed
17 underground, exclusive of any lines or facilities used or intended to be
18 used for the transmission of electric energy at nominal voltages in excess
19 of twenty-five thousand volts or having a circuit capacity in excess of
20 twelve thousand kva and facilities used or intended to be used for the
21 transmission of intelligence by microwave or radio and facilities such as
22 transformers, pull boxes, service terminals, pedestal terminals, splice
23 closures, apparatus cabinets and similar facilities ~~which~~ THAT normally
24 are above the surface in areas where service lines are underground in
25 accordance with standard underground practices, and on-the-ground
26 facilities attached to overhead facilities ~~which~~ THAT are used to connect
27 an underground system to overhead facilities.

28 13. "Underground conversion cost" means the costs to be paid by
29 each owner to each public service corporation or public agency by the
30 property owners within an underground conversion service area, as provided
31 in this article.

32 Sec. 14. Section 40-354, Arizona Revised Statutes, is amended to
33 read:

34 40-354. No extension of corporation commission jurisdiction
35 to public agencies, video service networks or cable
36 television systems

37 Nothing contained in this article ~~shall vest~~ VESTS any jurisdiction
38 over public agencies, VIDEO SERVICE NETWORKS or cable television systems
39 in the Arizona corporation commission.

40 Sec. 15. Section 40-360.24, Arizona Revised Statutes, is amended to
41 read:

42 40-360.24. Notice of damage to underground facility

43 A. In the event of any damage that results in a release from any
44 underground facility that transports natural gas, liquefied petroleum gas,
45 liquefied natural gas, petroleum products or any other hazardous gases or

1 liquids in connection with any excavation, the person responsible for the
2 excavation operations shall immediately notify the underground facilities
3 operator and 911 or the local emergency response agency.

4 B. In the event of any damage to or dislocation of any underground
5 facility or detectible underground location device in connection with any
6 excavation the person responsible for the excavation operations shall
7 immediately notify the underground facilities operator and shall not
8 attempt any repair to the damaged facility or device except the temporary
9 emergency repairs allowed by this section.

10 C. Temporary emergency repairs shall not be made by an excavator to
11 a public utility's or municipal corporation's natural gas, electric,
12 propane, hazardous liquid, communication, cable television **SYSTEM OR VIDEO**
13 **SERVICE NETWORK**, sewer system, wastewater or water facilities without the
14 consent of the underground facilities operator.

15 D. The excavation shall be left open until the arrival of
16 representatives of the underground facilities operator. ~~upon~~ **ON** receipt
17 of notice, the underground facilities operator shall dispatch its
18 representatives promptly, but in no event later than two working days, to
19 examine the underground facility and, if necessary, effect repairs.
20 Unless it would interfere with compliance with commission rules or
21 requirements regarding maintenance or restoration of service and repair of
22 facilities, the underground facilities operator shall immediately respond
23 to a notification for emergencies involving injury or damage.

24 Sec. 16. Section 40-360.41, Arizona Revised Statutes, is amended to
25 read:

26 **40-360.41. Definitions**

27 In this article, unless the context otherwise requires:

28 1. "Authorized person" means:

29 (a) An employee of a public utility ~~which~~ **THAT** produces, transmits
30 or delivers electricity.

31 (b) An employee of a public utility ~~which~~ **THAT** provides and whose
32 work relates to communication services or state, county or municipal
33 agencies ~~which~~ **THAT** have authorized circuit construction on or near the
34 poles or structures of a public utility.

35 (c) An employee of an industrial plant whose work relates to the
36 electrical system of the industrial plant.

37 (d) An employee of a cable television **OPERATOR, VIDEO SERVICE**
38 **PROVIDER** or communication services company or an employee of a contractor
39 of a cable television **OPERATOR, VIDEO SERVICE PROVIDER** or communication
40 services company if specifically authorized by the owner of the poles to
41 make **ATTACHMENTS FOR** cable television or communication services
42 ~~attachments~~ **OR VIDEO SERVICES**.

43 (e) An employee or agent of state, county or municipal agencies
44 ~~which~~ **THAT** have or whose work relates to overhead electrical lines or
45 circuit construction or conductors on poles or structures of any type.

1 2. "High voltage" means voltage in excess of six hundred volts
2 measured between conductors or between a conductor and the ground.

3 3. "Overhead line" means all bare or insulated electrical
4 conductors installed aboveground.

5 4. "Person" or "business entity" means those parties ~~who~~ THAT
6 contract to perform any function or activity ~~upon~~ ON any land, building,
7 highway or other premises.

8 5. "Public utility" includes public service corporations,
9 municipally owned systems and districts subject to article XIII, section
10 7, Constitution of Arizona.

11 Sec. 17. Section 40-491, Arizona Revised Statutes, is amended to
12 read:

13 40-491. Definitions

14 In this article, unless the context otherwise requires:

15 1. "Customer" means the person in whose name a utility service is
16 provided.

17 2. "Person" means an individual, partnership, firm, association or
18 corporation.

19 3. "Reconnection" means the restoration of utility service to a
20 customer or other person after service has been legally disconnected by
21 the utility.

22 4. "Tamper" or "tampering" means any of the following if committed
23 against property that is owned or operated by the utility for transmission
24 or distribution:

25 (a) Rearranging, damaging, altering, interfering with or otherwise
26 preventing the performance of a normal or customary function of utility
27 property.

28 (b) Connecting any wire, conduit or device to any utility property.

29 (c) Defacing, puncturing, removing, reversing or altering any
30 utility property.

31 (d) Preventing any meter from properly measuring or registering.

32 (e) Knowingly taking, receiving, using or converting to personal
33 use or the use of another any utility service that has not been measured
34 or authorized.

35 (f) Diverting or changing the intended course or path of the
36 utility service without the authorization or consent of the utility.

37 (g) Causing, procuring, permitting, aiding or abetting any person
38 to do any of the acts listed in this paragraph.

39 5. "Utility" means any public service corporation, licensed cable
40 television system OR VIDEO SERVICE NETWORK, telephone line or telegraph
41 line corporation or person engaged in the generation, transmission or
42 delivery of electricity, gas, telephone, cable television, telegraph or
43 water service, including this state or any political subdivision or agency
44 of this state.

1 6. "Utility service" means the provision of services or commodities
2 by the utility for compensation.

3 Sec. 18. Section 41-1954, Arizona Revised Statutes, is amended to
4 read:

5 41-1954. Powers and duties

6 A. In addition to the powers and duties of the agencies listed in
7 section 41-1953, subsection E, the department shall:

8 1. Administer the following services:

9 (a) Employment services, including manpower programs and work
10 training, field operations, technical services, unemployment compensation,
11 community work and training and other related functions in furtherance of
12 programs under the social security act, as amended, the Wagner-Peyser act,
13 as amended, the federal unemployment tax act, as amended, 33 United States
14 Code, the family support act of 1988 (P.L. 100-485) and other related
15 federal acts and titles.

16 (b) Individual and family services, which shall include a section
17 on aging, services to children, youth and adults and other related
18 functions in furtherance of social service programs under the social
19 security act, as amended, title IV, except parts B and E, grants to states
20 for aid and services to needy families with children and for ~~child-welfare~~
21 **CHILD WELFARE** services, title XX, grants to states for services, the older
22 Americans act, as amended, the family support act of 1988 (P.L. 100-485)
23 and other related federal acts and titles.

24 (c) Income maintenance services, including categorical assistance
25 programs, special services unit, child support collection services,
26 establishment of paternity services, maintenance and operation of a state
27 case registry of child support orders, a state directory of new hires, a
28 support payment clearinghouse and other related functions in furtherance
29 of programs under the social security act, title IV, grants to states for
30 aid and services to needy families with children and for ~~child-welfare~~
31 **CHILD WELFARE** services, title XX, grants to states for services, as
32 amended, and other related federal acts and titles.

33 (d) Rehabilitation services, including vocational rehabilitation
34 services and sections for the blind and visually impaired, communication
35 disorders, correctional rehabilitation and other related functions in
36 furtherance of programs under the vocational rehabilitation act, as
37 amended, the Randolph-Sheppard act, as amended, and other related federal
38 acts and titles.

39 (e) Administrative services, including the coordination of program
40 evaluation and research, interagency program coordination and in-service
41 training, planning, grants, development and management, information,
42 legislative liaison, budget, licensing and other related functions.

43 (f) Manpower planning, including a state manpower planning council
44 for the purposes of the federal-state-local cooperative manpower planning
45 system and other related functions in furtherance of programs under the

1 comprehensive employment and training act of 1973, as amended, and other
2 related federal acts and titles.

3 (g) Economic opportunity services, including the furtherance of
4 programs prescribed under the economic opportunity act of 1967, as
5 amended, and other related federal acts and titles.

6 (h) Intellectual disability and other developmental disability
7 programs, with emphasis on referral and purchase of services. The program
8 shall include educational, rehabilitation, treatment and training services
9 and other related functions in furtherance of programs under the
10 developmental disabilities services and facilities construction
11 act, ~~Public Law (P.L. 91-517),~~ and other related federal acts and titles.

12 (i) Nonmedical home and community based services and functions,
13 including ~~department designated~~ DEPARTMENT-DESIGNATED case management,
14 housekeeping services, chore services, home health aid, personal care,
15 visiting nurse services, adult day care or adult day health, respite
16 sitter care, attendant care, home delivered meals and other related
17 services and functions.

18 2. Provide a coordinated system of initial intake, screening,
19 evaluation and referral of persons served by the department.

20 3. Adopt rules it deems necessary or desirable to further the
21 objectives and programs of the department.

22 4. Formulate policies, plans and programs to effectuate the
23 missions and purposes of the department.

24 5. Employ and determine the conditions of employment and prescribe
25 the duties and powers of administrative, professional, technical,
26 secretarial, clerical and other persons subject to chapter 4, article 4
27 and, as applicable, article 5 of this title as may be necessary in the
28 performance of its duties, contract for the services of outside advisors,
29 consultants and aides as may be reasonably necessary and reimburse
30 department volunteers, designated by the director, for expenses in
31 transporting clients of the department on official business.

32 6. Make contracts and incur obligations within the general scope of
33 its activities and operations subject to the availability of funds.

34 7. Contract with or assist other departments, agencies and
35 institutions of the state, local and federal governments in the
36 furtherance of its purposes, objectives and programs.

37 8. Be designated as the single state agency for the purposes of
38 administering and in furtherance of each federally supported state plan.

39 9. Accept and disburse grants, matching funds and direct payments
40 from public or private agencies for the conduct of programs that are
41 consistent with the overall purposes and objectives of the department.

42 10. Provide information and advice on request by local, state and
43 federal agencies and by private citizens, business enterprises and
44 community organizations on matters within the scope of its duties subject
45 to the departmental rules on the confidentiality of information.

- 1 11. Establish and maintain separate financial accounts as required
2 by federal law or regulations.
- 3 12. Advise and make recommendations to the governor and the
4 legislature on all matters concerning its objectives.
- 5 13. Have an official seal that ~~shall be~~ IS judicially noticed.
- 6 14. Annually estimate the current year's population of each county,
7 city and town in this state, using the periodic census conducted by the
8 United States department of commerce, or its successor agency, as the
9 basis for such estimates and deliver such estimates to the economic
10 estimates commission before December 15.
- 11 15. Estimate the population of any newly annexed areas of a
12 political subdivision as of July 1 of the fiscal year in which the
13 annexation occurs and deliver such estimates as promptly as is feasible
14 after the annexation occurs to the economic estimates commission.
- 15 16. Establish and maintain a statewide program of services for
16 persons who are both hearing impaired and visually impaired and coordinate
17 appropriate services with other agencies and organizations to avoid
18 duplication of these services and to increase efficiency. The department
19 of economic security shall enter into agreements for the utilization of
20 the personnel and facilities of the department of economic security, the
21 department of health services and other appropriate agencies and
22 organizations in providing these services.
- 23 17. Establish and charge fees for deposit in the department of
24 economic security prelayoff assistance services fund to employers who
25 voluntarily participate in the services of the department that provide job
26 service and retraining for persons who have been or are about to be laid
27 off from employment. The department shall charge only those fees
28 necessary to cover the costs of administering the job service and
29 retraining services.
- 30 18. Establish a focal point for addressing the issue of hunger in
31 ~~Arizona~~ THIS STATE and provide coordination and assistance to public and
32 private nonprofit organizations that aid hungry persons and families
33 throughout this state. Specifically such activities shall include:
- 34 (a) Collecting and disseminating information regarding the location
35 and availability of surplus food for distribution to needy persons, the
36 availability of surplus food for donation to charity food bank
37 organizations, and the needs of charity food bank organizations for
38 surplus food.
- 39 (b) Coordinating the activities of federal, state, local and
40 private nonprofit organizations that provide food assistance to the
41 hungry.
- 42 (c) Accepting and disbursing federal monies, and any state monies
43 appropriated by the legislature, to private nonprofit organizations in
44 support of the collection, receipt, handling, storage and distribution of
45 donated or surplus food items.

1 (d) Providing technical assistance to private nonprofit
2 organizations that provide or intend to provide services to the hungry.

3 (e) Developing a state plan on hunger that, at a minimum,
4 identifies the magnitude of the hunger problem in this state, the
5 characteristics of the population in need, the availability and location
6 of charity food banks and the potential sources of surplus food, assesses
7 the effectiveness of the donated food collection and distribution network
8 and other efforts to alleviate the hunger problem, and recommends goals
9 and strategies to improve the status of the hungry. The state plan on
10 hunger shall be incorporated into the department's state comprehensive
11 plan prepared pursuant to section 41-1956.

12 (f) Establishing a special purpose advisory council on hunger
13 pursuant to section 41-1981.

14 19. Establish an office to address the issue of homelessness and to
15 provide coordination and assistance to public and private nonprofit
16 organizations that prevent homelessness or aid homeless individuals and
17 families throughout this state. These activities shall include:

18 (a) Promoting and participating in planning for the prevention of
19 homelessness and the development of services to homeless persons.

20 (b) Identifying and developing strategies for resolving barriers in
21 state agency service delivery systems that inhibit the provision and
22 coordination of appropriate services to homeless persons and persons in
23 danger of being homeless.

24 (c) Assisting in the coordination of the activities of federal,
25 state and local governments and the private sector that prevent
26 homelessness or provide assistance to homeless people.

27 (d) Assisting in obtaining and increasing funding from all
28 appropriate sources to prevent homelessness or assist in alleviating
29 homelessness.

30 (e) Serving as a clearinghouse on information regarding funding and
31 services available to assist homeless persons and persons in danger of
32 being homeless.

33 (f) Developing an annual state comprehensive homeless assistance
34 plan to prevent and alleviate homelessness.

35 (g) Submitting an annual report to the governor, the president of
36 the senate and the speaker of the house of representatives on the status
37 of homelessness and efforts to prevent and alleviate homelessness. **THE**
38 **DEPARTMENT SHALL PROVIDE A COPY OF THIS REPORT TO THE SECRETARY OF STATE.**

39 20. Cooperate with the Arizona-Mexico commission in the governor's
40 office and with researchers at universities in this state to collect data
41 and conduct projects in the United States and Mexico on issues that are
42 within the scope of the department's duties and that relate to quality of
43 life, trade and economic development in this state in a manner that will
44 help the Arizona-Mexico commission to assess and enhance the economic
45 competitiveness of this state and of the Arizona-Mexico region.

1 21. Exchange information, including case specific information, and
2 cooperate with the department of child safety for the administration of
3 the department of child safety's programs.

4 B. If the department of economic security has responsibility for
5 the care, custody or control of a child or is paying the cost of care for
6 a child, it may serve as representative payee to receive and administer
7 social security and United States department of veterans affairs benefits
8 and other benefits payable to such child. Notwithstanding any law to the
9 contrary, the department of economic security:

10 1. Shall deposit, pursuant to sections 35-146 and 35-147, such
11 monies as it receives to be retained separate and apart from the state
12 general fund on the books of the department of administration.

13 2. May use such monies to defray the cost of care and services
14 expended by the department of economic security for the benefit, welfare
15 and best interests of the child and invest any of the monies that the
16 director determines are not necessary for immediate use.

17 3. Shall maintain separate records to account for the receipt,
18 investment and disposition of funds received for each child.

19 4. On termination of the department of economic security's
20 responsibility for the child, shall release any funds remaining to the
21 child's credit in accordance with the requirements of the funding source
22 or in the absence of such requirements shall release the remaining funds
23 to:

24 (a) The child, if the child is at least eighteen years of age or is
25 emancipated.

26 (b) The person responsible for the child if the child is a minor
27 and not emancipated.

28 C. Subsection B of this section does not pertain to benefits
29 payable to or for the benefit of a child receiving services under title
30 36.

31 D. Volunteers reimbursed for expenses pursuant to subsection A,
32 paragraph 5 of this section are not eligible for workers' compensation
33 under title 23, chapter 6.

34 E. In implementing the temporary assistance for needy families
35 program pursuant to Public Law 104-193, the department shall provide for
36 cash assistance to ~~two-parent~~ TWO-PARENT families if both parents are able
37 to work only on documented participation by both parents in work
38 activities described in title 46, chapter 2, article 5, except that
39 payments may be made to families who do not meet the participation
40 requirements if:

41 1. It is determined on an individual case basis that they have
42 emergency needs.

43 2. The family is determined to be eligible for diversion from
44 long-term cash assistance pursuant to title 46, chapter 2, article 5.

1 F. The department shall provide for cash assistance under temporary
2 assistance for needy families pursuant to Public Law 104-193 to ~~two-parent~~
3 ~~TWO-PARENT~~ families for no longer than six months if both parents are able
4 to work, except that additional assistance may be provided on an
5 individual case basis to families with extraordinary circumstances. The
6 department shall establish by rule the criteria to be used to determine
7 eligibility for additional cash assistance.

8 G. The department shall adopt the following discount medical
9 payment system for persons who the department determines are eligible and
10 who are receiving rehabilitation services pursuant to subsection A,
11 paragraph 1, subdivision ~~(c)~~ (d) of this section:

12 1. For inpatient hospital admissions and outpatient hospital
13 services the department shall reimburse a hospital according to the rates
14 established by the Arizona health care cost containment system
15 administration pursuant to section 36-2903.01, subsection G.

16 2. The department's liability for a hospital claim under this
17 subsection is subject to availability of funds.

18 3. A hospital bill is considered received for purposes of
19 paragraph 5 of this subsection on initial receipt of the legible,
20 error-free claim form by the department if the claim includes the
21 following error-free documentation in legible form:

22 (a) An admission face sheet.

23 (b) An itemized statement.

24 (c) An admission history and physical.

25 (d) A discharge summary or an interim summary if the claim is
26 split.

27 (e) An emergency record, if admission was through the emergency
28 room.

29 (f) Operative reports, if applicable.

30 (g) A labor and delivery room report, if applicable.

31 4. The department shall require that the hospital pursue other
32 third-party payors before submitting a claim to the department. Payment
33 received by a hospital from the department pursuant to this subsection is
34 considered payment by the department of the department's liability for the
35 hospital bill. A hospital may collect any unpaid portion of its bill from
36 other ~~third party~~ ~~THIRD-PARTY~~ payors or in situations covered by title 33,
37 chapter 7, article 3.

38 5. For inpatient hospital admissions and outpatient hospital
39 services rendered on and after October 1, 1997, if the department receives
40 the claim directly from the hospital, the department shall pay a
41 hospital's rate established according to this section subject to the
42 following:

43 (a) If the hospital's bill is paid within thirty days of the date
44 the bill was received, the department shall pay ninety-nine ~~per cent~~
45 ~~PERCENT~~ of the rate.

1 (b) If the hospital's bill is paid after thirty days but within
2 sixty days of the date the bill was received, the department shall pay one
3 hundred ~~per cent~~ PERCENT of the rate.

4 (c) If the hospital's bill is paid any time after sixty days of the
5 date the bill was received, the department shall pay one hundred ~~per cent~~
6 PERCENT of the rate plus a fee of one ~~per cent~~ PERCENT per month for each
7 month or portion of a month following the sixtieth day of receipt of the
8 bill until the date of payment.

9 6. For medical services other than those for which a rate has been
10 established pursuant to section 36-2903.01, subsection G, the department
11 shall pay according to the Arizona health care cost containment system
12 capped fee-for-service schedule adopted pursuant to section 36-2904,
13 subsection K or any other established fee schedule the department
14 determines reasonable.

15 H. The department shall not pay claims for services pursuant to
16 this section that are submitted more than nine months after the date of
17 service for which the payment is claimed.

18 I. To assist in the location of persons or assets for the purpose
19 of establishing paternity, establishing, modifying or enforcing child
20 support obligations and other related functions, the department has
21 access, including automated access if the records are maintained in an
22 automated database, to records of state and local government agencies,
23 including:

24 1. Vital statistics, including records of marriage, birth and
25 divorce.

26 2. State and local tax and revenue records, including information
27 on residence address, employer, income and assets.

28 3. Records concerning real and titled personal property.

29 4. Records of occupational and professional licenses.

30 5. Records concerning the ownership and control of corporations,
31 partnerships and other business entities.

32 6. Employment security records.

33 7. Records of agencies administering public assistance programs.

34 8. Records of the motor vehicle division of the department of
35 transportation.

36 9. Records of the state department of corrections.

37 10. Any system used by a state agency to locate a person for motor
38 vehicle or law enforcement purposes, including access to information
39 contained in the Arizona criminal justice information system.

40 J. Notwithstanding subsection I of this section, the department or
41 its agents shall not seek or obtain information on the assets of an
42 individual unless paternity is presumed pursuant to section 25-814 or
43 established.

1 K. Access to records of the department of revenue pursuant to
2 subsection I of this section shall be provided in accordance with section
3 42-2003.

4 L. The department also has access to certain records held by
5 private entities with respect to child support obligors or obligees, or
6 individuals against whom such an obligation is sought. The information
7 shall be obtained as follows:

8 1. In response to a child support subpoena issued by the department
9 pursuant to section 25-520, the names and addresses of these persons and
10 the names and addresses of the employers of these persons, as appearing in
11 customer records of public utilities, ~~and cable television companies~~
12 OPERATORS AND VIDEO SERVICE PROVIDERS.

13 2. Information on these persons held by financial institutions.

14 M. Pursuant to department rules, the department may compromise or
15 settle any support debt owed to the department if the director or an
16 authorized agent determines that it is in the best interest of ~~the~~ THIS
17 state and after considering each of the following factors:

18 1. The obligor's financial resources.

19 2. The cost of further enforcement action.

20 3. The likelihood of recovering the full amount of the debt.

21 N. Notwithstanding any law to the contrary, a state or local
22 governmental agency or private entity is not subject to civil liability
23 for the disclosure of information made in good faith to the department
24 pursuant to this section.

25 Sec. 19. Section 42-5063, Arizona Revised Statutes, is amended to
26 read:

27 42-5063. Utilities classification; definitions

28 A. The utilities classification is comprised of the business of:

29 1. Producing and furnishing or furnishing to consumers natural or
30 artificial gas and water.

31 2. Providing to retail electric customers ancillary services,
32 electric distribution services, electric generation services, electric
33 transmission services and other services related to providing electricity.

34 B. The utilities classification does not include:

35 1. Sales of ancillary services, electric distribution services,
36 electric generation services, electric transmission services and other
37 services related to providing electricity, gas or water to a person who
38 resells the services.

39 2. Sales of natural gas or liquefied petroleum gas used to propel a
40 motor vehicle.

41 3. Sales of alternative fuel, as defined in section 1-215, to a
42 used oil fuel burner who has received a permit to burn used oil or used
43 oil fuel under section 49-426 or 49-480.

44 4. Sales of ancillary services, electric distribution services,
45 electric generation services, electric transmission services and other

1 services that are related to providing electricity to a retail electric
2 customer who is located outside this state for use outside this state if
3 the electricity is delivered to a point of sale outside this state.

4 5. Sales or other transfers of renewable energy credits or any
5 other unit created to track energy derived from renewable energy
6 resources. For the purposes of this paragraph, "renewable energy credit"
7 means a unit created administratively by the corporation commission or
8 governing body of a public power utility to track kilowatt hours of
9 electricity derived from a renewable energy resource or the kilowatt hour
10 equivalent of conventional energy resources displaced by distributed
11 renewable energy resources.

12 6. The leasing or renting of space to make attachments to utility
13 poles as follows:

14 (a) By a person that is engaged in business under this section.

15 (b) To a person that is engaged in business under this section or
16 section 42-5064 or that is a cable operator.

17 C. The tax base for the utilities classification is the gross
18 proceeds of sales or gross income derived from the business, but the
19 following shall be deducted from the tax base:

20 1. Revenues received by a municipally owned utility in the form of
21 fees charged to persons constructing residential, commercial or industrial
22 developments or connecting residential, commercial or industrial
23 developments to a municipal utility system or systems if the fees are
24 segregated and used only for capital expansion, system enlargement or debt
25 service of the utility system or systems.

26 2. Revenues received by any person or persons owning a utility
27 system in the form of reimbursement or contribution compensation for
28 property and equipment installed to provide utility access to, on or
29 across the land of an actual utility consumer if the property and
30 equipment become the property of the utility. This deduction shall not
31 exceed the value of such property and equipment.

32 3. Gross proceeds of sales or gross income derived from sales to:

33 (a) Qualifying hospitals as defined in section 42-5001.

34 (b) A qualifying health care organization as defined in section
35 42-5001 if the tangible personal property is used by the organization
36 solely to provide health and medical related educational and charitable
37 services.

38 4. The portion of gross proceeds of sales or gross income that is
39 derived from sales to a qualified environmental technology manufacturer,
40 producer or processor as defined in section 41-1514.02 of a utility
41 product and that is used directly in environmental technology
42 manufacturing, producing or processing. This paragraph shall apply for
43 twenty full consecutive calendar or fiscal years from the date the first
44 paper manufacturing machine is placed in service. In the case of a
45 qualified environmental technology manufacturer, producer or processor who

1 does not manufacture paper, the time period shall begin with the date the
2 first manufacturing, processing or production equipment is placed in
3 service.

4 5. The portion of gross proceeds of sales or gross income
5 attributable to transfers of electricity by any retail electric customer
6 owning a solar photovoltaic energy generating system to an electric
7 distribution system, if the electricity transferred is generated by the
8 customer's system.

9 6. Gross proceeds of sales or gross income derived from sales of
10 electricity, natural gas or liquefied petroleum gas to a qualified
11 manufacturing or smelting business. A utility that claims this deduction
12 shall report each month, on a form prescribed by the department, the name
13 and address of each qualified manufacturing or smelting business for which
14 this deduction is taken. This paragraph applies to gas transportation
15 services. For the purposes of this paragraph:

16 (a) "Gas transportation services" means the services of
17 transporting natural gas to a natural gas customer or to a natural gas
18 distribution facility if the natural gas was purchased from a supplier
19 other than the utility.

20 (b) "Manufacturing" means the performance as a business of an
21 integrated series of operations that places tangible personal property in
22 a form, composition or character different from that in which it was
23 acquired and transforms it into a different product with a distinctive
24 name, character or use. Manufacturing does not include job printing,
25 publishing, packaging, mining, generating electricity or operating a
26 restaurant.

27 (c) "Qualified manufacturing or smelting business" means one of the
28 following:

29 (i) A business that manufactures or smelts tangible products in
30 this state, of which at least fifty-one percent of the manufactured or
31 smelted products will be exported out of state for incorporation into
32 another product or sold out of state for a final sale.

33 (ii) A business that derives at least fifty-one percent of its
34 gross income from the sale of manufactured or smelted products
35 manufactured or smelted by the business.

36 (iii) A business that uses at least fifty-one percent of its square
37 footage in this state for manufacturing or smelting and business
38 activities directly related to manufacturing or smelting.

39 (iv) A business that employs at least fifty-one percent of its
40 workforce in this state in manufacturing or smelting and business
41 activities directly related to manufacturing or smelting.

42 (v) A business that uses at least fifty-one percent of the value of
43 its capitalized assets in this state, as reflected on the business's books
44 and records, for manufacturing or smelting and business activities
45 directly related to manufacturing or smelting.

1 (d) "Smelting" means to melt or fuse a metalliferous mineral, often
2 with an accompanying chemical change, usually to separate the metal.

3 7. Gross proceeds of sales or gross income derived from sales of
4 electricity or natural gas to a business that operates an international
5 operations center in this state and that is certified by the Arizona
6 commerce authority pursuant to section 41-1520.

7 D. For the purposes of this section:

8 1. "Ancillary services" means those services so designated in
9 federal energy regulatory commission order 888 adopted in 1996 that
10 include the services necessary to support the transmission of electricity
11 from resources to loads while maintaining reliable operation of the
12 transmission system according to good utility practice.

13 2. "Cable operator" has the same meaning prescribed in section
14 9-505 **AND INCLUDES A VIDEO SERVICE PROVIDER.**

15 3. "Electric distribution service" means distributing electricity
16 to retail electric customers through the use of electric distribution
17 facilities.

18 4. "Electric generation service" means providing electricity for
19 sale to retail electric customers but excluding electric distribution or
20 transmission services.

21 5. "Electric transmission service" means transmitting electricity
22 to retail electric customers or to electric distribution facilities so
23 classified by the federal energy regulatory commission or, to the extent
24 permitted by law, so classified by the Arizona corporation commission.

25 6. "Other services" includes metering, meter reading services,
26 billing and collecting services.

27 7. "Retail electric customer" means a person who purchases
28 electricity for that person's own use, including use in that person's
29 trade or business and not for resale, redistribution or retransmission.

30 8. "Utility pole" means any wooden, metal or other pole used for
31 utility purposes and the pole's appurtenances that are attached or
32 authorized for attachment by the person controlling the pole.

33 Sec. 20. Section 42-5064, Arizona Revised Statutes, is amended to
34 read:

35 **42-5064. Telecommunications classification; definitions**

36 A. The telecommunications classification is comprised of the
37 business of providing intrastate telecommunications services. The
38 telecommunications classification does not include:

39 1. Sales of intrastate telecommunications services by a cable
40 operator or by a microwave television transmission system that transmits
41 television programming to multiple subscribers and that is operated
42 pursuant to 47 Code of Federal Regulations parts 21 and 74.

43 2. Sales of internet access or application services to the person's
44 subscribers and customers. For the purposes of this paragraph:

1 (a) "Application services" means software applications provided
2 remotely using hypertext transfer protocol or another network protocol and
3 purchased by or for any school district, charter school, community college
4 or state university to assess or test student learning or to promote
5 curriculum design or enhancement.

6 (b) "Curriculum design or enhancement" means planning, implementing
7 or reporting on courses of study, lessons, assignments or other learning
8 activities.

9 3. The leasing or renting of space to make attachments to utility
10 poles as follows:

11 (a) By a person that is engaged in business under this section.

12 (b) To a person that is engaged in business under section 42-5063
13 or this section or that is a cable operator.

14 B. The tax base for the telecommunications classification is the
15 gross proceeds of sales or gross income derived from the business,
16 including the gross income derived from tolls, subscriptions and services
17 on behalf of subscribers or from the publication of a directory of the
18 names of subscribers. However, the gross proceeds of sales or gross
19 income derived from the following shall be deducted from the tax base:

20 1. Sales of intrastate telecommunications services to:

21 (a) Other persons engaged in businesses classified under the
22 telecommunications classification for use in such business.

23 (b) A direct broadcast satellite television or data transmission
24 service that operates pursuant to 47 Code of Federal Regulations part 25
25 for use in its direct broadcast satellite television or data transmission
26 operation by a facility described in section 42-5061, subsection B,
27 paragraph 15, subdivision (b).

28 2. End user common line charges established by federal
29 communications commission regulations (47 Code of Federal Regulations
30 section 69.104(a)).

31 3. Carrier access charges established by federal communications
32 commission regulations (47 Code of Federal Regulations sections 69.105(a)
33 through 69.118).

34 4. Sales of direct broadcast satellite television services pursuant
35 to 47 Code of Federal Regulations part 25 by a direct broadcast satellite
36 television service that operates pursuant to 47 Code of Federal
37 Regulations part 25.

38 5. Telecommunications services purchased with a prepaid calling
39 card, or a prepaid authorization number for telecommunications services,
40 that is taxable under section 42-5061.

41 C. A person that is engaged in a transient lodging business subject
42 to taxation under section 42-5070 and that provides telephone, fax or
43 internet access services to its customers at an additional charge, which
44 is separately stated on the customer invoice, is considered to be engaged
45 in business subject to taxation under this section for the purposes of

1 taxing the gross proceeds of sales or gross income derived from providing
2 those services.

3 D. The gross proceeds of sales or gross income derived from a
4 bundled transaction of services that are taxable pursuant to section
5 42-5023 are subject to the following:

6 1. A telecommunications service provider who can reasonably
7 identify the portion of the sales price of the bundled transaction derived
8 from charges for nontaxable services is subject to tax only on the gross
9 proceeds of sales or gross income derived from the taxable services. For
10 the purposes of this section, the telecommunications service provider may
11 elect to reasonably identify the portion of the sales price of the bundled
12 transaction derived from charges for nontaxable services by using
13 allocation percentages derived from the telecommunications service
14 provider's entire service area, including territories outside of this
15 state. On request, the department may require the telecommunications
16 service provider to provide this allocation information. The
17 reasonableness of the allocation is subject to audit by the department.

18 2. Notwithstanding sections 42-1118, 42-1120 and 42-1121, the
19 telecommunications service provider shall waive the right to file a claim
20 for a refund of taxes paid on the bundled transaction if the taxes paid
21 are based on the allocation percentage the telecommunications service
22 provider had determined to be reasonable at the beginning of the tax
23 period at issue.

24 3. The burden of proof is on the telecommunications service
25 provider to establish that the gross proceeds of sales or gross income is
26 derived from charges for nontaxable services.

27 E. For the purposes of this section:

28 1. "Bundled transaction" means a sale of multiple services in which
29 both of the following apply:

30 (a) The sale consists of both taxable and nontaxable services.

31 (b) The telecommunications service provider charges a customer one
32 sales price for all services that are sold instead of separately charging
33 for each individual service.

34 2. "Cable operator" has the same meaning prescribed in section
35 9-505 **AND INCLUDES A VIDEO SERVICE PROVIDER.**

36 3. "Internet" means the computer and telecommunications facilities
37 that comprise the interconnected worldwide network of networks that employ
38 the transmission control protocol or internet protocol, or any predecessor
39 or successor protocol, to communicate information of all kinds by wire or
40 radio.

41 4. "Internet access" means a service that enables users to access
42 content, information, ~~electronic mail~~ **E-MAIL** or other services over the
43 internet. Internet access does not include telecommunications services
44 provided by a common carrier.

1 5. "Intrastate telecommunications services" means transmitting
2 signs, signals, writings, images, sounds, messages, data or other
3 information of any nature by wire, radio waves, light waves or other
4 electromagnetic means if the information transmitted originates and
5 terminates in this state.

6 6. "Utility pole" means any wooden, metal or other pole used for
7 utility purposes and the pole's appurtenances that are attached or
8 authorized for attachment by the person controlling the pole.

9 Sec. 21. Section 42-5069, Arizona Revised Statutes, is amended to
10 read:

11 42-5069. Commercial lease classification; definitions

12 A. The commercial lease classification is comprised of the business
13 of leasing for a consideration the use or occupancy of real property.

14 B. A person who, as a lessor, leases or rents for a consideration
15 under one or more leases or rental agreements the use or occupancy of real
16 property that is used by the lessee for commercial purposes is deemed to
17 be engaged in business and subject to the tax imposed by article 1 of this
18 chapter, but this subsection does not include leases or rentals of real
19 property used for residential or agricultural purposes.

20 C. The commercial lease classification does not include:

21 1. Any business activities that are classified under the transient
22 lodging classification.

23 2. Activities engaged in by the Arizona exposition and state fair
24 board or county fair commissions in connection with events sponsored by
25 those entities.

26 3. Leasing real property to a lessee who subleases the property if
27 the lessee is engaged in business classified under the commercial lease
28 classification or the transient lodging classification.

29 4. Leasing real property pursuant to a written lease agreement
30 entered into before December 1, 1967. This exclusion does not apply to
31 the businesses of hotels, guest houses, dude ranches and resorts, rooming
32 houses, apartment houses, office buildings, automobile storage garages,
33 parking lots or tourist camps, or to the extension or renewal of any such
34 written lease agreement.

35 5. Leasing real property between affiliated companies, businesses,
36 persons or reciprocal insurers. For the purposes of this paragraph:

37 (a) "Affiliated companies, businesses, persons or reciprocal
38 insurers" means the lessor holds a controlling interest in the lessee, the
39 lessee holds a controlling interest in the lessor, affiliated persons hold
40 a controlling interest in both the lessor and the lessee, or an unrelated
41 person holds a controlling interest in both the lessor and lessee.

42 (b) "Affiliated persons" means members of an individual's family or
43 persons who have ownership or control of a business entity.

1 (c) "Controlling interest" means direct or indirect ownership of at
2 least eighty percent of the voting shares of a corporation or of the
3 interests in a company, business or person other than a corporation.

4 (d) "Members of an individual's family" means the individual's
5 spouse and brothers and sisters, whether by whole or half blood, including
6 adopted persons, ancestors and lineal descendants.

7 (e) "Reciprocal insurers" has the same meaning prescribed in
8 section 20-762.

9 6. Leasing real property for boarding horses.

10 7. Leasing or renting real property or the right to use real
11 property at exhibition events in this state sponsored, operated or
12 conducted by a nonprofit organization that is exempt from taxation under
13 section 501(c)(3), 501(c)(4) or 501(c)(6) of the internal revenue code if
14 the organization is associated with major league baseball teams or a
15 national touring professional golfing association and no part of the
16 organization's net earnings inures to the benefit of any private
17 shareholder or individual. This paragraph does not apply to an
18 organization that is owned, managed or controlled, in whole or in part, by
19 a major league baseball team, or its owners, officers, employees or
20 agents, or by a major league baseball association or professional golfing
21 association, or its owners, officers, employees or agents, unless the
22 organization conducted or operated exhibition events in this state before
23 January 1, 2018 that were exempt from taxation under section 42-5073.

24 8. Leasing or renting real property or the right to use real
25 property for use as a rodeo featuring primarily farm and ranch animals in
26 this state sponsored, operated or conducted by a nonprofit organization
27 that is exempt from taxation under section 501(c)(3), 501(c)(4),
28 501(c)(6), 501(c)(7) or 501(c)(8) of the internal revenue code and no part
29 of the organization's net earnings inures to the benefit of any private
30 shareholder or individual.

31 9. Leasing or renting dwelling units, lodging facilities or trailer
32 or mobile home spaces if the units, facilities or spaces are intended to
33 serve as the principal or permanent place of residence for the lessee or
34 renter or if the unit, facility or space is leased or rented to a single
35 tenant thirty or more consecutive days.

36 10. Leasing or renting real property and improvements for use
37 primarily for religious worship by a nonprofit organization that is exempt
38 from taxation under section 501(c)(3) of the internal revenue code and no
39 part of the organization's net earnings inures to the benefit of any
40 private shareholder or individual.

41 11. Leasing or renting real property used for agricultural purposes
42 under either of the following circumstances:

43 (a) The lease or rental is between family members, trusts, estates,
44 corporations, partnerships, joint venturers or similar entities, or any
45 combination thereof, if the individuals or at least eighty percent of the

1 beneficiaries, shareholders, partners or joint venturers share a family
2 relationship as parents or ancestors of parents, children or descendants
3 of children, siblings, cousins of the first degree, aunts, uncles, nieces
4 or nephews of the first degree, spouses of any of the listed relatives and
5 listed relatives by the half-blood or by adoption.

6 (b) The lessor leases or rents real property used for agricultural
7 purposes under no more than three leases or rental agreements.

8 12. Leasing, renting or granting the right to use real property to
9 vendors or exhibitors by a trade or industry association that is a
10 qualifying organization pursuant to section 513(d)(3)(C) of the internal
11 revenue code for a period not to exceed twenty-one days in connection with
12 an event that meets all of the following conditions:

13 (a) The majority of such vending or exhibition activities relate to
14 the nature of the trade or business sponsoring the event.

15 (b) The event is held in conjunction with a formal business meeting
16 of the trade or industry association.

17 (c) The event is organized by the persons engaged in the particular
18 trade or industry.

19 13. Leasing, renting or granting the right to use real property for
20 a period not to exceed twenty-one days by a coliseum, civic center, civic
21 plaza, convention center, auditorium or arena owned by this state or any
22 of its political subdivisions.

23 14. Leasing or subleasing real property used by a nursing care
24 institution as defined in section 36-401 that is licensed pursuant to
25 title 36, chapter 4.

26 15. Leasing or renting an eligible facility as defined in section
27 28-7701.

28 16. Granting or providing rights to real property that constitute a
29 profit à prendre for the severance of minerals, including all rights to
30 use the surface or subsurface of the property as is necessary or
31 convenient to the right to sever the minerals. This paragraph does not
32 exclude from the commercial lease classification leasehold rights to the
33 real property that are granted in addition to and not included within the
34 right of profit à prendre, but the tax base for the grant of such a
35 leasehold right, if the gross income derived from the grant is not
36 separately stated from the gross income derived from the grant of the
37 profit à prendre, shall not exceed the fair market value of the leasehold
38 rights computed after excluding the value of all rights under the profit à
39 prendre. For the purposes of this paragraph, "profit à prendre" means a
40 right to use the land of another to mine minerals, and carries with it the
41 right of entry and the right to remove and take the minerals from the land
42 and also includes the right to use the surface of the land as is necessary
43 and convenient for exercise of the profit.

1 17. The leasing or renting of space to make attachments to utility
2 poles as follows:

3 (a) By a person that is engaged in business under section 42-5063
4 or 42-5064 or that is a cable operator.

5 (b) To a person that is engaged in business under section 42-5063
6 or 42-5064 or that is a cable operator.

7 D. The tax base for the commercial lease classification is the
8 gross proceeds of sales or gross income derived from the business, but
9 reimbursements to the lessor for utility service shall be deducted from
10 the tax base.

11 E. Notwithstanding section 42-1104, subsection B, paragraph 1,
12 subdivision (b) and paragraph 2, the failure to file tax returns for the
13 commercial lease classification that report gross income derived from any
14 agreement that constitutes, in whole or in part, a grant of a right of
15 profit à prendre for the severance of minerals does not constitute an
16 exception to the general rule for the statute of limitations.

17 F. For the purposes of this section:

18 1. "Cable operator" has the same meaning prescribed in section
19 9-505 **AND INCLUDES A VIDEO SERVICE PROVIDER.**

20 2. "Leasing" includes renting.

21 3. "Real property" includes any improvements, rights or interest in
22 such property.

23 4. "Utility pole" means any wooden, metal or other pole used for
24 utility purposes and the pole's appurtenances that are attached or
25 authorized for attachment by the person controlling the pole.

26 Sec. 22. Section 42-5071, Arizona Revised Statutes, is amended to
27 read:

28 42-5071. Personal property rental classification; definitions

29 A. The personal property rental classification is comprised of the
30 business of leasing or renting tangible personal property for a
31 consideration. The tax does not apply to:

32 1. Leasing or renting films, tapes or slides used by theaters or
33 movies, which are engaged in business under the amusement classification,
34 or used by television stations or radio stations.

35 2. Activities engaged in by the Arizona exposition and state fair
36 board or county fair commissions in connection with events sponsored by
37 such entities.

38 3. Leasing or renting tangible personal property by a parent
39 corporation to a subsidiary corporation or by a subsidiary corporation to
40 another subsidiary of the same parent corporation if taxes were paid under
41 this chapter on the gross proceeds or gross income accruing from the
42 initial sale of the tangible personal property. For the purposes of this
43 paragraph, "subsidiary" means a corporation of which at least eighty
44 percent of the voting shares are owned by the parent corporation.

1 4. Operating coin-operated washing, drying and dry cleaning
2 machines or coin-operated car washing machines at establishments for the
3 use of such machines.

4 5. Leasing or renting tangible personal property for incorporation
5 into or comprising any part of a qualified environmental technology
6 facility as described in section 41-1514.02. This paragraph shall apply
7 for ten full consecutive calendar or fiscal years following the initial
8 lease or rental by each qualified environmental technology manufacturer,
9 producer or processor.

10 6. Leasing or renting aircraft, flight simulators or similar
11 training equipment to students or staff by nonprofit, accredited
12 educational institutions that offer associate or baccalaureate degrees in
13 aviation or aerospace related fields.

14 7. Leasing or renting photographs, transparencies or other creative
15 works used by this state on internet websites, in magazines or in other
16 publications that encourage tourism.

17 8. Leasing or renting certified ignition interlock devices
18 installed pursuant to the requirements prescribed by section 28-1461. For
19 the purposes of this paragraph, "certified ignition interlock device" has
20 the same meaning prescribed in section 28-1301.

21 9. The leasing or renting of space to make attachments to utility
22 poles, as follows:

23 (a) By a person that is engaged in business under section 42-5063
24 or 42-5064 or that is a cable operator.

25 (b) To a person that is engaged in business under section 42-5063
26 or 42-5064 or that is a cable operator.

27 10. Leasing or renting billboards that are designed, intended or
28 used to advertise or inform and that are visible from any street, road or
29 other highway.

30 B. The tax base for the personal property rental classification is
31 the gross proceeds of sales or gross income derived from the business, but
32 the gross proceeds of sales or gross income derived from the following
33 shall be deducted from the tax base:

34 1. Reimbursements by the lessee to the lessor of a motor vehicle
35 for payments by the lessor of the applicable fees and taxes imposed by
36 sections 28-2003, 28-2352, 28-2402, 28-2481 and 28-5801, title 28, chapter
37 15, article 2 and article IX, section 11, Constitution of Arizona, to the
38 extent such amounts are separately identified as such fees and taxes and
39 are billed to the lessee.

40 2. Leases or rentals of tangible personal property that, if it had
41 been purchased instead of leased or rented by the lessee, would have been
42 exempt under:

43 (a) Section 42-5061, subsection A, paragraph 8, 9, 12, 13, 25, 29,
44 49 or 53.

1 (b) Section 42-5061, subsection B, except that a lease or rental of
2 new machinery or equipment is not exempt pursuant to section 42-5061,
3 subsection B, paragraph 13 if the lease is for less than two years.

4 (c) Section 42-5061, subsection I, paragraph 1.

5 (d) Section 42-5061, subsection M.

6 3. Motor vehicle fuel and use fuel that are subject to a tax
7 imposed under title 28, chapter 16, article 1, sales of use fuel to a
8 holder of a valid single trip use fuel tax permit issued under section
9 28-5739 and sales of aviation fuel that are subject to the tax imposed
10 under section 28-8344.

11 4. Leasing or renting a motor vehicle subject to and on which the
12 fee has been paid under title 28, chapter 16, article 4.

13 5. Amounts received by a motor vehicle dealer for the first month
14 of a lease payment if the lease and the lease payment for the first month
15 of the lease are transferred to a third-party leasing company.

16 C. Sales of tangible personal property to be leased or rented to a
17 person engaged in a business classified under the personal property rental
18 classification are deemed to be resale sales.

19 D. In computing the tax base, the gross proceeds of sales or gross
20 income from the lease or rental of a motor vehicle does not include any
21 amount attributable to the car rental surcharge under section 5-839,
22 28-5810 or 48-4234.

23 E. Until December 31, 1988, leasing or renting animals for
24 recreational purposes is exempt from the tax imposed by this section.
25 Beginning January 1, 1989, the gross proceeds or gross income from leasing
26 or renting animals for recreational purposes is subject to taxation under
27 this section. Tax liabilities, penalties and interest paid for taxable
28 periods before January 1, 1989 shall not be refunded unless the taxpayer
29 requesting the refund provides proof satisfactory to the department that
30 the monies paid as taxes will be returned to the customer.

31 F. For the purposes of this section:

32 1. "Cable operator" has the same meaning prescribed by section
33 9-505 **AND INCLUDES A VIDEO SERVICE PROVIDER.**

34 2. "Utility pole" means any wooden, metal or other pole used for
35 utility purposes and the pole's appurtenances that are attached or
36 authorized for attachment by the person controlling the pole.

37 Sec. 23. Section 42-6004, Arizona Revised Statutes, as amended by
38 Laws 2018, chapter 17, section 1, chapter 249, section 6 and chapter 341,
39 section 2, is amended to read:

40 **42-6004. Exemption from municipal tax; definitions**

41 A. A city, town or special taxing district shall not levy a
42 transaction privilege, sales, use or other similar tax on:

43 1. Exhibition events in this state sponsored, conducted or operated
44 by a nonprofit organization that is exempt from taxation under section
45 501(c)(3), 501(c)(4) or 501(c)(6) of the internal revenue code if the

1 organization is associated with a major league baseball team or a national
2 touring professional golfing association and no part of the organization's
3 net earnings inures to the benefit of any private shareholder or
4 individual. This paragraph does not apply to an organization that is
5 owned, managed or controlled, in whole or in part, by a major league
6 baseball team, or its owners, officers, employees or agents, or by a major
7 league baseball association or professional golfing association, or its
8 owners, officers, employees or agents, unless the organization conducted
9 or operated exhibition events in this state before January 1, 2018 that
10 were exempt from state transaction privilege tax under section 42-5073.

11 2. Interstate telecommunications services, which include that
12 portion of telecommunications services, such as subscriber line service,
13 allocable by federal law to interstate telecommunications service.

14 3. Sales of warranty or service contracts.

15 4. Sales of motor vehicles to nonresidents of this state for use
16 outside this state if the motor vehicle dealer ships or delivers the motor
17 vehicle to a destination outside this state.

18 5. Interest on finance contracts.

19 6. Dealer documentation fees on the sales of motor vehicles.

20 7. Orthodontic devices dispensed by a dental professional who is
21 licensed under title 32, chapter 11 to a patient as part of the practice
22 of dentistry.

23 8. Sales of internet access services to the person's subscribers
24 and customers. For the purposes of this paragraph:

25 (a) "Internet" means the computer and telecommunications facilities
26 that comprise the interconnected worldwide network of networks that employ
27 the transmission control protocol or internet protocol, or any predecessor
28 or successor protocol, to communicate information of all kinds by wire or
29 radio.

30 (b) "Internet access" means a service that enables users to access
31 content, information, electronic mail or other services over the internet.
32 Internet access does not include telecommunication services provided by a
33 common carrier.

34 9. The gross proceeds of sales or gross income retained by the
35 Arizona exposition and state fair board from ride ticket sales at the
36 annual Arizona state fair.

37 10. Leasing real property between affiliated companies, businesses,
38 persons or reciprocal insurers. For the purposes of this paragraph:

39 (a) "Affiliated companies, businesses, persons or reciprocal
40 insurers" means the lessor holds a controlling interest in the lessee, the
41 lessee holds a controlling interest in the lessor, affiliated persons hold
42 a controlling interest in both the lessor and the lessee, or an unrelated
43 person holds a controlling interest in both the lessor and lessee.

44 (b) "Affiliated persons" means members of the individual's family
45 or persons who have ownership or control of a business entity.

1 (c) "Controlling interest" means direct or indirect ownership of at
2 least eighty percent of the voting shares of a corporation or of the
3 interests in a company, business or person other than a corporation.

4 (d) "Members of the individual's family" means the individual's
5 spouse and brothers and sisters, whether by whole or half blood, including
6 adopted persons, ancestors and lineal descendants.

7 (e) "Reciprocal insurer" has the same meaning prescribed in section
8 20-762.

9 11. The gross proceeds of sales or gross income derived from a
10 contract for the installation, assembly, repair or maintenance of
11 machinery, equipment or other tangible personal property that is described
12 in section 42-5061, subsection B and that has independent functional
13 utility, pursuant to the following provisions:

14 (a) The deduction provided in this paragraph includes the gross
15 proceeds of sales or gross income derived from all of the following:

16 (i) Any activity performed on machinery, equipment or other
17 tangible personal property with independent functional utility.

18 (ii) Any activity performed on any tangible personal property
19 relating to machinery, equipment or other tangible personal property with
20 independent functional utility in furtherance of any of the purposes
21 provided for under subdivision (d) of this paragraph.

22 (iii) Any activity that is related to the activities described in
23 items (i) and (ii) of this subdivision, including inspecting the
24 installation of or testing the machinery, equipment or other tangible
25 personal property.

26 (b) The deduction provided in this paragraph does not include gross
27 proceeds of sales or gross income from the portion of any contracting
28 activity that consists of the development of, or modification to, real
29 property in order to facilitate the installation, assembly, repair,
30 maintenance or removal of machinery, equipment or other tangible personal
31 property described in section 42-5061, subsection B.

32 (c) The deduction provided in this paragraph shall be determined
33 without regard to the size or useful life of the machinery, equipment or
34 other tangible personal property.

35 (d) For the purposes of this paragraph, "independent functional
36 utility" means that the machinery, equipment or other tangible personal
37 property can independently perform its function without attachment to real
38 property, other than attachment for any of the following purposes:

39 (i) Assembling the machinery, equipment or other tangible personal
40 property.

41 (ii) Connecting items of machinery, equipment or other tangible
42 personal property to each other.

43 (iii) Connecting the machinery, equipment or other tangible
44 personal property, whether as an individual item or as a system of items,
45 to water, power, gas, communication or other services.

1 (iv) Stabilizing or protecting the machinery, equipment or other
2 tangible personal property during operation by bolting, burying or
3 performing other dissimilar nonpermanent connections to either real
4 property or real property improvements.

5 12. The leasing or renting of certified ignition interlock devices
6 installed pursuant to the requirements prescribed by section 28-1461. For
7 the purposes of this paragraph, "certified ignition interlock device" has
8 the same meaning prescribed in section 28-1301.

9 13. Computer data center equipment sold to the owner, operator or
10 qualified colocation tenant of a computer data center that is certified by
11 the Arizona commerce authority under section 41-1519 or an authorized
12 agent of the owner, operator or qualified colocation tenant during the
13 qualification period for use in the qualified computer data center. For
14 the purposes of this paragraph, "computer data center", "computer data
15 center equipment", "qualification period" and "qualified colocation
16 tenant" have the same meanings prescribed in section 41-1519.

17 14. The gross proceeds of sales or gross income derived from a
18 contract with the owner of real property or improvements to real property
19 for the maintenance, repair, replacement or alteration of existing
20 property, except as specified in this paragraph. The gross proceeds of
21 sales or gross income derived from a de minimis amount of modification
22 activity does not subject the contract or any part of the contract to tax.
23 For the purposes of this paragraph:

24 (a) Each contract is independent of another contract, except that
25 any change order that directly relates to the scope of work of the
26 original contract shall be treated the same as the original contract under
27 this paragraph, regardless of the amount of modification activities
28 included in the change order. If a change order does not directly relate
29 to the scope of work of the original contract, the change order shall be
30 treated as a new contract, with the tax treatment of any subsequent change
31 order to follow the tax treatment of the contract to which the scope of
32 work of the subsequent change order directly relates.

33 (b) Any term not defined in this paragraph that is defined in
34 section 42-5075 has the same meaning prescribed in section 42-5075.

35 (c) This paragraph does not apply to a contract that primarily
36 involves surface or subsurface improvements to land and that is subject to
37 title 28, chapter 19, 20 or 22 or title 34, chapter 2 or 6 even if the
38 contract also includes vertical improvements. If a city or town imposes a
39 tax on contracts that are subject to procurement processes under those
40 provisions, the city or town shall include in the request for proposals a
41 notice to bidders when those projects are subject to the tax. This
42 subdivision does not apply to contracts with:

43 (i) Community facilities districts, fire districts, county
44 television improvement districts, community park maintenance districts,
45 cotton pest control districts, hospital districts, pest abatement

1 districts, health service districts, agricultural improvement districts,
2 county free library districts, county jail districts, county stadium
3 districts, special health care districts, public health services
4 districts, theme park districts or revitalization districts.

5 (ii) Any special taxing district not specified in item (i) of this
6 subdivision if the district does not substantially engage in the
7 modification, maintenance, repair, replacement or alteration of surface or
8 subsurface improvements to land.

9 15. Monitoring services relating to an alarm system as defined in
10 section 32-101.

11 16. Tangible personal property, job printing or publications sold
12 to or purchased by, or tangible personal property leased, rented or
13 licensed for use to or by, a qualifying health sciences educational
14 institution as defined in section 42-5001.

15 17. The transfer of title or possession of coal back and forth
16 between an owner or operator of a power plant and a person who is
17 responsible for refining coal if both of the following apply:

18 (a) The transfer of title or possession of the coal is for the
19 purpose of refining the coal.

20 (b) The title or possession of the coal is transferred back to the
21 owner or operator of the power plant after completion of the coal refining
22 process. For the purposes of this subdivision, "coal refining process"
23 means the application of a coal additive system that aids the reduction of
24 power plant emissions during the combustion of coal and the treatment of
25 flue gas.

26 18. Tangible personal property incorporated or fabricated into a
27 project described in paragraph 14 of this subsection, that is located
28 within the exterior boundaries of an Indian reservation for which the
29 owner, as defined in section 42-5075, of the project is an Indian tribe or
30 an affiliated Indian. For the purposes of this paragraph:

31 (a) "Affiliated Indian" means an individual native American Indian
32 who is duly registered on the tribal rolls of the Indian tribe for whose
33 benefit the Indian reservation was established.

34 (b) "Indian reservation" means all lands that are within the limits
35 of areas set aside by the United States for the exclusive use and
36 occupancy of an Indian tribe by treaty, law or executive order and that
37 are recognized as Indian reservations by the United States department of
38 the interior.

39 (c) "Indian tribe" means any organized nation, tribe, band or
40 community that is recognized as an Indian tribe by the United States
41 department of the interior and includes any entity formed under the laws
42 of that Indian tribe.

43 19. The charges for the leasing or renting of space to make
44 attachments to utility poles as follows:

1 (a) By a person that is engaged in the business of providing or
2 furnishing electrical services or telecommunication services or that is a
3 cable operator.

4 (b) To a person that is engaged in the business of providing or
5 furnishing electrical services or telecommunication services or that is a
6 cable operator.

7 20. Until March 1, 2017, the gross proceeds of sales or gross
8 income derived from entry fees paid by participants for events that
9 consist of a run, walk, swim or bicycle ride or a similar event, or any
10 combination of these events.

11 21. The gross proceeds of sales or gross income derived from entry
12 fees paid by participants for events that are operated or conducted by
13 nonprofit organizations that are exempt from taxation under section
14 501(c)(3) of the internal revenue code and of which no part of the
15 organization's net earnings inures to the benefit of any private
16 shareholder or individual, if the event consists of a run, walk, swim or
17 bicycle ride or a similar event, or any combination of these events.

18 B. A city, town or other taxing jurisdiction shall not levy a
19 transaction privilege, sales, use, franchise or other similar tax or fee,
20 however denominated, on natural gas or liquefied petroleum gas used to
21 propel a motor vehicle.

22 C. A city, town or other taxing jurisdiction shall not levy a
23 transaction privilege, sales, gross receipts, use, franchise or other
24 similar tax or fee, however denominated, on gross proceeds of sales or
25 gross income derived from any of the following:

26 1. A motor carrier's use on the public highways in this state if
27 the motor carrier is subject to a fee prescribed in title 28, chapter 16,
28 article 4.

29 2. Leasing, renting or licensing a motor vehicle subject to and on
30 which the fee has been paid under title 28, chapter 16, article 4.

31 3. The sale of a motor vehicle and any repair and replacement parts
32 and tangible personal property becoming a part of such motor vehicle to a
33 motor carrier who is subject to a fee prescribed in title 28, chapter 16,
34 article 4 and who is engaged in the business of leasing, renting or
35 licensing such property.

36 4. Incarcerating or detaining in a privately operated prison, jail
37 or detention facility prisoners who are under the jurisdiction of the
38 United States, this state or any other state or a political subdivision of
39 this state or of any other state.

40 5. Transporting for hire persons, freight or property by light
41 motor vehicles subject to a fee under title 28, chapter 15, article 4.

42 6. Any amount attributable to development fees that are incurred in
43 relation to the construction, development or improvement of real property
44 and paid by the taxpayer as defined in the model city tax code or by a

1 contractor providing services to the taxpayer. For the purposes of this
2 paragraph:

3 (a) The attributable amount shall not exceed the value of the
4 development fees actually imposed.

5 (b) The attributable amount is equal to the total amount of
6 development fees paid by the taxpayer or by a contractor providing
7 services to the taxpayer and the total development fees credited in
8 exchange for the construction of, contribution to or dedication of real
9 property for providing public infrastructure, public safety or other
10 public services necessary to the development. The real property must be
11 the subject of the development fees.

12 (c) "Development fees" means fees imposed to offset capital costs
13 of providing public infrastructure, public safety or other public services
14 to a development and authorized pursuant to section 9-463.05, section
15 11-1102 or title 48 regardless of the jurisdiction to which the fees are
16 paid.

17 7. Any amount attributable to fees collected by transportation
18 network companies issued a permit pursuant to section 28-9552.

19 8. Transporting for hire persons by transportation network company
20 drivers on transactions involving transportation network services as
21 defined in section 28-9551.

22 9. Transporting for hire persons by vehicle for hire companies that
23 are issued permits pursuant to section 28-9503.

24 10. Transporting for hire persons by vehicle for hire drivers on
25 transactions involving vehicle for hire services as defined in section
26 28-9501.

27 D. A city, town or other taxing jurisdiction shall not levy a
28 transaction privilege, sales, use, franchise or other similar tax or fee,
29 however denominated, in excess of one-tenth of one percent of the value of
30 the entire product mined, smelted, extracted, refined, produced or
31 prepared for sale, profit or commercial use, on persons engaged in the
32 business of mineral processing, except to the extent that the tax is
33 computed on the gross proceeds or gross income from sales at retail.

34 E. In computing the tax base, any city, town or other taxing
35 jurisdiction shall not include in the gross proceeds of sales or gross
36 income:

37 1. A manufacturer's cash rebate on the sales price of a motor
38 vehicle if the buyer assigns the buyer's right in the rebate to the
39 retailer.

40 2. The waste tire disposal fee imposed pursuant to section 44-1302.

41 F. A city or town shall not levy a use tax on the storage, use or
42 consumption of tangible personal property in the city or town by a school
43 district or charter school.

1 G. For the purposes of this section:
2 1. "Cable operator" has the same meaning prescribed in section
3 9-505 **AND INCLUDES A VIDEO SERVICE PROVIDER.**
4 2. "Electrical services" means transmitting or distributing
5 electricity, electric lights, current or power over lines, wires or
6 cables.
7 3. "Telecommunication services" means transmitting or relaying
8 sound, visual image, data, information, images or material over lines,
9 wires or cables by radio signal, light beam, telephone, telegraph or other
10 electromagnetic means.
11 4. "Utility pole" means any wooden, metal or other pole used for
12 utility purposes and the pole's appurtenances that are attached or
13 authorized for attachment by the person controlling the pole.
14 Sec. 24. Section 42-6004, Arizona Revised Statutes, as amended by
15 Laws 2018, chapter 17, section 1, chapter 249, section 6, chapter 263,
16 section 3 and chapter 341, section 2, is amended to read:
17 **42-6004. Exemption from municipal tax; definitions**
18 A. A city, town or special taxing district shall not levy a
19 transaction privilege, sales, use or other similar tax on:
20 1. Exhibition events in this state sponsored, conducted or operated
21 by a nonprofit organization that is exempt from taxation under section
22 501(c)(3), 501(c)(4) or 501(c)(6) of the internal revenue code if the
23 organization is associated with a major league baseball team or a national
24 touring professional golfing association and no part of the organization's
25 net earnings inures to the benefit of any private shareholder or
26 individual. This paragraph does not apply to an organization that is
27 owned, managed or controlled, in whole or in part, by a major league
28 baseball team, or its owners, officers, employees or agents, or by a major
29 league baseball association or professional golfing association, or its
30 owners, officers, employees or agents, unless the organization conducted
31 or operated exhibition events in this state before January 1, 2018 that
32 were exempt from state transaction privilege tax under section 42-5073.
33 2. Interstate telecommunications services, which include that
34 portion of telecommunications services, such as subscriber line service,
35 allocable by federal law to interstate telecommunications service.
36 3. Sales of warranty or service contracts.
37 4. Sales of motor vehicles to nonresidents of this state for use
38 outside this state if the motor vehicle dealer ships or delivers the motor
39 vehicle to a destination outside this state.
40 5. Interest on finance contracts.
41 6. Dealer documentation fees on the sales of motor vehicles.
42 7. Orthodontic devices dispensed by a dental professional who is
43 licensed under title 32, chapter 11 to a patient as part of the practice
44 of dentistry.

1 8. Sales of internet access services to the person's subscribers
2 and customers. For the purposes of this paragraph:

3 (a) "Internet" means the computer and telecommunications facilities
4 that comprise the interconnected worldwide network of networks that employ
5 the transmission control protocol or internet protocol, or any predecessor
6 or successor protocol, to communicate information of all kinds by wire or
7 radio.

8 (b) "Internet access" means a service that enables users to access
9 content, information, electronic mail or other services over the internet.
10 Internet access does not include telecommunication services provided by a
11 common carrier.

12 9. The gross proceeds of sales or gross income retained by the
13 Arizona exposition and state fair board from ride ticket sales at the
14 annual Arizona state fair.

15 10. Leasing real property between affiliated companies, businesses,
16 persons or reciprocal insurers. For the purposes of this paragraph:

17 (a) "Affiliated companies, businesses, persons or reciprocal
18 insurers" means the lessor holds a controlling interest in the lessee, the
19 lessee holds a controlling interest in the lessor, affiliated persons hold
20 a controlling interest in both the lessor and the lessee, or an unrelated
21 person holds a controlling interest in both the lessor and lessee.

22 (b) "Affiliated persons" means members of the individual's family
23 or persons who have ownership or control of a business entity.

24 (c) "Controlling interest" means direct or indirect ownership of at
25 least eighty percent of the voting shares of a corporation or of the
26 interests in a company, business or person other than a corporation.

27 (d) "Members of the individual's family" means the individual's
28 spouse and brothers and sisters, whether by whole or half blood, including
29 adopted persons, ancestors and lineal descendants.

30 (e) "Reciprocal insurer" has the same meaning prescribed in section
31 20-762.

32 11. The gross proceeds of sales or gross income derived from a
33 contract for the installation, assembly, repair or maintenance of
34 machinery, equipment or other tangible personal property that is described
35 in section 42-5061, subsection B and that has independent functional
36 utility, pursuant to the following provisions:

37 (a) The deduction provided in this paragraph includes the gross
38 proceeds of sales or gross income derived from all of the following:

39 (i) Any activity performed on machinery, equipment or other
40 tangible personal property with independent functional utility.

41 (ii) Any activity performed on any tangible personal property
42 relating to machinery, equipment or other tangible personal property with
43 independent functional utility in furtherance of any of the purposes
44 provided for under subdivision (d) of this paragraph.

1 (iii) Any activity that is related to the activities described in
2 items (i) and (ii) of this subdivision, including inspecting the
3 installation of or testing the machinery, equipment or other tangible
4 personal property.

5 (b) The deduction provided in this paragraph does not include gross
6 proceeds of sales or gross income from the portion of any contracting
7 activity that consists of the development of, or modification to, real
8 property in order to facilitate the installation, assembly, repair,
9 maintenance or removal of machinery, equipment or other tangible personal
10 property described in section 42-5061, subsection B.

11 (c) The deduction provided in this paragraph shall be determined
12 without regard to the size or useful life of the machinery, equipment or
13 other tangible personal property.

14 (d) For the purposes of this paragraph, "independent functional
15 utility" means that the machinery, equipment or other tangible personal
16 property can independently perform its function without attachment to real
17 property, other than attachment for any of the following purposes:

18 (i) Assembling the machinery, equipment or other tangible personal
19 property.

20 (ii) Connecting items of machinery, equipment or other tangible
21 personal property to each other.

22 (iii) Connecting the machinery, equipment or other tangible
23 personal property, whether as an individual item or as a system of items,
24 to water, power, gas, communication or other services.

25 (iv) Stabilizing or protecting the machinery, equipment or other
26 tangible personal property during operation by bolting, burying or
27 performing other dissimilar nonpermanent connections to either real
28 property or real property improvements.

29 12. The leasing or renting of certified ignition interlock devices
30 installed pursuant to the requirements prescribed by section 28-1461. For
31 the purposes of this paragraph, "certified ignition interlock device" has
32 the same meaning prescribed in section 28-1301.

33 13. Computer data center equipment sold to the owner, operator or
34 qualified colocation tenant of a computer data center that is certified by
35 the Arizona commerce authority under section 41-1519 or an authorized
36 agent of the owner, operator or qualified colocation tenant during the
37 qualification period for use in the qualified computer data center. For
38 the purposes of this paragraph, "computer data center", "computer data
39 center equipment", "qualification period" and "qualified colocation
40 tenant" have the same meanings prescribed in section 41-1519.

41 14. The gross proceeds of sales or gross income derived from a
42 contract with the owner of real property or improvements to real property
43 for the maintenance, repair, replacement or alteration of existing
44 property, except as specified in this paragraph. The gross proceeds of
45 sales or gross income derived from a de minimis amount of modification

1 activity does not subject the contract or any part of the contract to tax.
2 For the purposes of this paragraph:

3 (a) Each contract is independent of another contract, except that
4 any change order that directly relates to the scope of work of the
5 original contract shall be treated the same as the original contract under
6 this paragraph, regardless of the amount of modification activities
7 included in the change order. If a change order does not directly relate
8 to the scope of work of the original contract, the change order shall be
9 treated as a new contract, with the tax treatment of any subsequent change
10 order to follow the tax treatment of the contract to which the scope of
11 work of the subsequent change order directly relates.

12 (b) Any term not defined in this paragraph that is defined in
13 section 42-5075 has the same meaning prescribed in section 42-5075.

14 (c) This paragraph does not apply to a contract that primarily
15 involves surface or subsurface improvements to land and that is subject to
16 title 28, chapter 19, 20 or 22 or title 34, chapter 2 or 6 even if the
17 contract also includes vertical improvements. If a city or town imposes a
18 tax on contracts that are subject to procurement processes under those
19 provisions, the city or town shall include in the request for proposals a
20 notice to bidders when those projects are subject to the tax. This
21 subdivision does not apply to contracts with:

22 (i) Community facilities districts, fire districts, county
23 television improvement districts, community park maintenance districts,
24 cotton pest control districts, hospital districts, pest abatement
25 districts, health service districts, agricultural improvement districts,
26 county free library districts, county jail districts, county stadium
27 districts, special health care districts, public health services
28 districts, theme park districts or revitalization districts.

29 (ii) Any special taxing district not specified in item (i) of this
30 subdivision if the district does not substantially engage in the
31 modification, maintenance, repair, replacement or alteration of surface or
32 subsurface improvements to land.

33 15. Monitoring services relating to an alarm system as defined in
34 section 32-101.

35 16. Tangible personal property, job printing or publications sold
36 to or purchased by, or tangible personal property leased, rented or
37 licensed for use to or by, a qualifying health sciences educational
38 institution as defined in section 42-5001.

39 17. The sale of coal.

40 18. Tangible personal property incorporated or fabricated into a
41 project described in paragraph 14 of this subsection, that is located
42 within the exterior boundaries of an Indian reservation for which the
43 owner, as defined in section 42-5075, of the project is an Indian tribe or
44 an affiliated Indian. For the purposes of this paragraph:

1 (a) "Affiliated Indian" means an individual native American Indian
2 who is duly registered on the tribal rolls of the Indian tribe for whose
3 benefit the Indian reservation was established.

4 (b) "Indian reservation" means all lands that are within the limits
5 of areas set aside by the United States for the exclusive use and
6 occupancy of an Indian tribe by treaty, law or executive order and that
7 are recognized as Indian reservations by the United States department of
8 the interior.

9 (c) "Indian tribe" means any organized nation, tribe, band or
10 community that is recognized as an Indian tribe by the United States
11 department of the interior and includes any entity formed under the laws
12 of that Indian tribe.

13 19. The charges for the leasing or renting of space to make
14 attachments to utility poles as follows:

15 (a) By a person that is engaged in the business of providing or
16 furnishing electrical services or telecommunication services or that is a
17 cable operator.

18 (b) To a person that is engaged in the business of providing or
19 furnishing electrical services or telecommunication services or that is a
20 cable operator.

21 20. Until March 1, 2017, the gross proceeds of sales or gross
22 income derived from entry fees paid by participants for events that
23 consist of a run, walk, swim or bicycle ride or a similar event, or any
24 combination of these events.

25 21. The gross proceeds of sales or gross income derived from entry
26 fees paid by participants for events that are operated or conducted by
27 nonprofit organizations that are exempt from taxation under section
28 501(c)(3) of the internal revenue code and of which no part of the
29 organization's net earnings inures to the benefit of any private
30 shareholder or individual, if the event consists of a run, walk, swim or
31 bicycle ride or a similar event, or any combination of these events.

32 B. A city, town or other taxing jurisdiction shall not levy a
33 transaction privilege, sales, use, franchise or other similar tax or fee,
34 however denominated, on natural gas or liquefied petroleum gas used to
35 propel a motor vehicle.

36 C. A city, town or other taxing jurisdiction shall not levy a
37 transaction privilege, sales, gross receipts, use, franchise or other
38 similar tax or fee, however denominated, on gross proceeds of sales or
39 gross income derived from any of the following:

40 1. A motor carrier's use on the public highways in this state if
41 the motor carrier is subject to a fee prescribed in title 28, chapter 16,
42 article 4.

43 2. Leasing, renting or licensing a motor vehicle subject to and on
44 which the fee has been paid under title 28, chapter 16, article 4.

1 3. The sale of a motor vehicle and any repair and replacement parts
2 and tangible personal property becoming a part of such motor vehicle to a
3 motor carrier who is subject to a fee prescribed in title 28, chapter 16,
4 article 4 and who is engaged in the business of leasing, renting or
5 licensing such property.

6 4. Incarcerating or detaining in a privately operated prison, jail
7 or detention facility prisoners who are under the jurisdiction of the
8 United States, this state or any other state or a political subdivision of
9 this state or of any other state.

10 5. Transporting for hire persons, freight or property by light
11 motor vehicles subject to a fee under title 28, chapter 15, article 4.

12 6. Any amount attributable to development fees that are incurred in
13 relation to the construction, development or improvement of real property
14 and paid by the taxpayer as defined in the model city tax code or by a
15 contractor providing services to the taxpayer. For the purposes of this
16 paragraph:

17 (a) The attributable amount shall not exceed the value of the
18 development fees actually imposed.

19 (b) The attributable amount is equal to the total amount of
20 development fees paid by the taxpayer or by a contractor providing
21 services to the taxpayer and the total development fees credited in
22 exchange for the construction of, contribution to or dedication of real
23 property for providing public infrastructure, public safety or other
24 public services necessary to the development. The real property must be
25 the subject of the development fees.

26 (c) "Development fees" means fees imposed to offset capital costs
27 of providing public infrastructure, public safety or other public services
28 to a development and authorized pursuant to section 9-463.05, section
29 11-1102 or title 48 regardless of the jurisdiction to which the fees are
30 paid.

31 7. Any amount attributable to fees collected by transportation
32 network companies issued a permit pursuant to section 28-9552.

33 8. Transporting for hire persons by transportation network company
34 drivers on transactions involving transportation network services as
35 defined in section 28-9551.

36 9. Transporting for hire persons by vehicle for hire companies that
37 are issued permits pursuant to section 28-9503.

38 10. Transporting for hire persons by vehicle for hire drivers on
39 transactions involving vehicle for hire services as defined in section
40 28-9501.

41 D. A city, town or other taxing jurisdiction shall not levy a
42 transaction privilege, sales, use, franchise or other similar tax or fee,
43 however denominated, in excess of one-tenth of one percent of the value of
44 the entire product mined, smelted, extracted, refined, produced or
45 prepared for sale, profit or commercial use, on persons engaged in the

1 business of mineral processing, except to the extent that the tax is
2 computed on the gross proceeds or gross income from sales at retail.

3 E. In computing the tax base, any city, town or other taxing
4 jurisdiction shall not include in the gross proceeds of sales or gross
5 income:

6 1. A manufacturer's cash rebate on the sales price of a motor
7 vehicle if the buyer assigns the buyer's right in the rebate to the
8 retailer.

9 2. The waste tire disposal fee imposed pursuant to section 44-1302.

10 F. A city or town shall not levy a use tax on the storage, use or
11 consumption of tangible personal property in the city or town by a school
12 district or charter school.

13 G. For the purposes of this section:

14 1. "Cable operator" has the same meaning prescribed in section
15 9-505 **AND INCLUDES A VIDEO SERVICE PROVIDER.**

16 2. "Electrical services" means transmitting or distributing
17 electricity, electric lights, current or power over lines, wires or
18 cables.

19 3. "Telecommunication services" means transmitting or relaying
20 sound, visual image, data, information, images or material over lines,
21 wires or cables by radio signal, light beam, telephone, telegraph or other
22 electromagnetic means.

23 4. "Utility pole" means any wooden, metal or other pole used for
24 utility purposes and the pole's appurtenances that are attached or
25 authorized for attachment by the person controlling the pole.

26 Sec. 25. Section 44-1273, Arizona Revised Statutes, is amended to
27 read:

28 **44-1273. Limited exemptions**

29 A. The following sellers are not required to register and, except
30 for section 44-1278, subsection B and section 44-1282, are exempt from
31 this article:

32 1. A person acting within the scope of a license issued under
33 title 20.

34 2. A person who is either a:

35 (a) Charitable organization as defined in section 44-6551, this
36 state or any county or municipality of this state or its agencies.

37 (b) Political party, candidate for federal, state or local office
38 or campaign committee required to file financial information with federal,
39 state or local election agencies.

40 3. A person making telephone solicitations without the intent to
41 complete and who does not complete the sales presentation during the
42 telephone solicitation but completes the sales presentation at a later
43 face-to-face meeting between the solicitor and the consumer provided that
44 the later face-to-face meeting is not for the purpose of collecting the
45 payment or delivering any item purchased.

1 4. A person who after making a telephone contact with a consumer
2 sends the consumer descriptive literature and does not require payment
3 before the consumer's review of the descriptive literature and the person
4 is not conducting a solicitation involving any of the following:

5 (a) The sale of an investment or an opportunity for an investment
6 that is not registered with any state or federal authority.

7 (b) A prize promotion or premium.

8 (c) A recovery service.

9 (d) A business opportunity or merchandise related to a business
10 opportunity.

11 5. A person or solicitor for a person who operates a retail
12 business establishment under the same name as the name used in the
13 solicitation of sales by telephone, if on a continuing basis all of the
14 following apply:

15 (a) Merchandise is displayed and offered for sale or services are
16 offered for sale and provided at the person's business establishment.

17 (b) At least fifty ~~per cent~~ PERCENT of the person's business
18 involves the buyer obtaining the merchandise at the person's business
19 establishment.

20 (c) The person holds a transaction privilege tax license pursuant
21 to title 42, chapter 5.

22 6. A person or solicitor for a person soliciting another business
23 if all of the following apply:

24 (a) At least fifty ~~per cent~~ PERCENT of the person's dollar volume
25 consists of repeat sales to existing businesses.

26 (b) The person does not conduct a prize promotion that requires or
27 implies that to win a consumer must pay money or purchase merchandise.

28 (c) Neither the person nor any of the person's principals has
29 within twenty years been convicted in any state of a felony or crime of
30 moral turpitude, breach of trust, fraud, theft, dishonesty or violation of
31 telephone solicitation laws, been subject to a final judgment in a civil
32 action involving fraud, deceit or misrepresentation or been subject to an
33 administrative order involving fraud, deceit, misrepresentation or any
34 violation of telephone solicitations laws of any agency of this state,
35 another state, the federal government, a territory of the United States or
36 another country.

37 (d) The person is not selling a business opportunity or merchandise
38 related to a business opportunity.

39 7. A person or solicitor on behalf of a person who solicits sales
40 by periodically publishing and delivering a catalog to consumers if all of
41 the following apply:

42 (a) The catalog contains a written description or illustration of
43 each item offered for sale and the price of each item offered for sale.

44 (b) The catalog includes the business address or home office
45 address of the person.

1 (c) The catalog includes at least twenty-four pages of written
2 material and illustrations.

3 (d) The catalog is distributed in more than one state and has an
4 annual circulation by mail of at least two hundred fifty thousand.

5 B. The following sellers shall file a limited registration
6 statement pursuant to section 44-1272.01 and, except for sections 44-1278
7 and 44-1282, are exempt from this article:

8 1. A person acting within the scope of a license issued under title
9 6 or 32 or by the corporation commission pursuant to this title, except
10 persons licensed under title 6, chapter 13.

11 2. If soliciting within the scope of the license, any licensed
12 securities, commodities or investments broker or dealer or investment
13 advisor or any licensed associated person of a securities, commodities or
14 investments broker or dealer or investment advisor.

15 3. An issuer or a subsidiary of an issuer that has a class of
16 securities that is subject to section 12 of the securities exchange act of
17 1934 (15 United States Code sections 78a through 78mm) and that is either
18 registered or exempt from registration under paragraph (A), (B), (C), (E),
19 (F), (G) or (H) or subsection (g)(2) of section 12 of the act. A
20 subsidiary of an issuer that qualifies for exemption under this paragraph
21 is not exempt unless at least sixty ~~per cent~~ PERCENT of the voting power
22 of the subsidiary's shares is owned by the qualifying issuer or issuers.

23 4. A person certificated or regulated by the corporation commission
24 pursuant to title 40, chapter 2 or a subsidiary of that person or a
25 federal communications commission licensed cellular telephone company or
26 radio telecommunication services provider.

27 5. A person making telephone solicitations for a newspaper of
28 general circulation, a magazine or a licensed ~~or franchised~~ cable
29 television system OR VIDEO SERVICE PROVIDER.

30 6. An issuer or subsidiary of an issuer that is subject to
31 registration under chapter 12, article 6 or 7 of this title or that is
32 exempt from registration under section 44-1843, subsection A, paragraph 1,
33 2, 3, 4, 5, 7 or 9.

34 7. A person making telephone solicitations for the sale or purchase
35 of books, recordings, videocassettes and similar goods through a
36 membership group or club regulated by the federal trade commission or
37 through a contractual plan or arrangement such as a continuity plan,
38 subscription arrangement, series arrangement or single purchase under
39 which the seller ships goods to a consumer who has consented in advance to
40 receive those goods and the recipient is given the opportunity to review
41 goods for at least seven days and to receive a full refund for return of
42 undamaged goods.

43 8. A person or solicitor for a person when soliciting previous
44 customers, if all of the following apply:

1 (a) The person is not offering to sell or selling a security that
2 is not registered with any state or federal authority.

3 (b) The person makes the solicitation under the same name as the
4 name used to sell merchandise to the customer previously.

5 (c) The person does not operate a recovery service.

6 (d) The person does not conduct a prize promotion that requires a
7 consumer to, or implies that to win a consumer must, pay money or purchase
8 merchandise.

9 (e) The person has not, or any of its principals have not, within
10 twenty years been convicted in any state of a felony or a crime of moral
11 turpitude, breach of trust, fraud, theft, dishonesty or a violation of
12 telephone solicitation laws, been subject to a final judgment in a civil
13 action involving fraud, deceit or misrepresentation or been subject to an
14 administrative order involving fraud, deceit, misrepresentation or any
15 violation of telephone solicitation laws of any agency of this state,
16 another state, the federal government, a territory of the United States or
17 another country.

18 9. A person making telephone solicitations exclusively for the
19 purpose of the sale of telephone answering services to be provided by that
20 person or that person's employer.

21 10. Any bank holding company, bank, financial institution, trust
22 company, savings and loan association, credit union, mortgage banker or
23 broker, consumer lender or insurer that is licensed or supervised by an
24 official or agency of this state, any other state or the United States,
25 including any parent, subsidiary or affiliate of these institutions.

26 11. A person providing telemarketing sales service continuously for
27 at least five years under the same ownership and control that derives
28 seventy-five ~~per cent~~ PERCENT of its gross telemarketing sales revenues
29 from contracts with persons exempted by this section. A seller using an
30 exempt telemarketing sales service is not exempt unless otherwise
31 qualifying for an exemption under this section.

32 C. On request by the secretary of state, the director of the
33 department of insurance shall provide a current list in a mutually
34 acceptable electronic format to the secretary of state of the requested
35 licensees described in subsection A, paragraph 1 of this section that
36 includes all of the following information:

37 1. The true legal name of the seller.

38 2. All of the names under which the seller is doing business or
39 intends to do business.

40 3. The complete street address of the physical location of the
41 principal place of business of the seller and the telephone number for the
42 location.

43 4. The name and address of the seller's agent who is authorized to
44 receive service of process in this state.

1 D. In any civil proceeding alleging a violation of this article,
2 the burden of proving an exemption or an exception from a definition is on
3 the person claiming the exemption or exception. In any criminal
4 proceeding in which a violation of this article is alleged, the burden of
5 producing evidence to support a defense based on an exemption or an
6 exception from a definition is on the person claiming the exemption or
7 exception.

8 E. Any person or solicitor exempted in part from this article by
9 this section shall not make or submit a charge to a consumer's credit card
10 account or a consumer's checking, savings, share or similar account unless
11 any of the following applies:

12 1. The person provides that the consumer may receive a full refund
13 for the return of undamaged and unused goods or a cancellation of services
14 by providing notice to the person within seven days after the date that
15 the consumer receives the merchandise and the person processes:

16 (a) A full refund within thirty days after the date that the person
17 receives the returned merchandise from the consumer.

18 (b) A full refund within thirty days after the purchaser of
19 services cancels an order for the services or a pro rata refund for any
20 services not yet performed for the consumer.

21 2. The person provides the consumer with a signed copy of a written
22 contract that includes the person's name, address and business telephone
23 number and that fully describes the merchandise offered by the person, the
24 total price to be charged by the person and any terms or conditions
25 affecting the sale.

26 3. The person is either a:

27 (a) Charitable organization as defined in section 44-6551, this
28 state or any county or municipality of this state or its agencies.

29 (b) Political party, candidate for federal, state or local office
30 or campaign committee required to file financial information with federal,
31 state or local election agencies.

32 Sec. 26. Section 48-620, Arizona Revised Statutes, is amended to
33 read:

34 48-620. Improvement districts for underground utility and
35 cable television facilities in public rights-of-way
36 and easements; procedures; costs; definitions

37 A. Subject to the limitations contained in this section, the powers
38 and duties of the governing body of a municipality for establishing
39 underground utility facilities are as provided in this article for other
40 types of improvement districts.

41 B. Notwithstanding section 48-507, after the governing body passes
42 a resolution or notice declaring its intention to order an improvement
43 district for underground utility facilities, the governing body shall hold
44 a hearing at least thirty days after the completion of the posting and
45 publication of the notice of intention pursuant to section 48-506. At the

1 hearing, the governing body shall consider the issue of ordering an
2 election on the formation of the improvement district and shall receive
3 public comment on the proposed district. Section 48-507, regarding
4 written protests of the proposed improvement, does not apply to a district
5 formed pursuant to this section. The governing body may only order the
6 election on the issue of formation of the district if the owners of real
7 property in the district have signed and submitted petitions to the clerk
8 of the governing body in support of the formation of the district. The
9 petitions shall comply with the following:

10 1. Clearly state that they are petitions in support of the
11 formation of an underground utility improvement district and shall
12 specifically describe in words or by use of a map the location of the
13 proposed district's boundaries. The petitions shall require the signer's
14 signature, name and address or description of the property that is owned
15 in the district in a manner sufficient to determine ownership through the
16 use of public records.

17 2. Be signed by owners of a majority of the real property within
18 the boundaries of the proposed district as measured by square footage or
19 acreage owned. Signatures ~~shall~~ ARE not ~~be~~ required to be notarized and
20 for property with more than one owner, the signature of one owner is
21 binding on the remaining owners of the property. On submittal to the
22 clerk of the governing body, the petitions are a public record. Ownership
23 of property ~~shall be~~ IS as of the date of the hearing and ~~shall be~~ IS
24 determined by records of the county assessor or other public records
25 regarding property ownership. For purposes of this paragraph, "owner"
26 means a person, association, corporation or other entity without regard to
27 residency.

28 C. If the governing body finds that sufficient signatures are
29 submitted pursuant to subsection B of this section, the governing body may
30 proceed with a simplified ballot card election pursuant to subsection G of
31 this section. If there are not sufficient signatures, the governing body
32 shall not proceed with the formation of the district. If no registered
33 voters reside within the area of the proposed district, an election is not
34 required and the governing body may declare the formation of the district.

35 D. The requirement pursuant to section 48-577 that plans and
36 specifications be filed prior to adoption of the resolution of intention
37 may be satisfied by a general plan showing at least the general location
38 and type of facilities to be constructed. Actual plans and specifications
39 shall be filed following the adoption of the resolution ordering the
40 election regarding the improvement but ~~prior to~~ BEFORE the election and
41 the recording of the assessment and warrant. A person interested and
42 objecting to an improvement or to the extent of the assessment district
43 for a district established pursuant to this section may file a written
44 protest with the city or town clerk within thirty days after completion or
45 posting of the notice, or within thirty days after the date of the last

1 publication of the notice if that date is after the completion of the
2 posting.

3 E. The requirement pursuant to section 48-584 for notice of the
4 award of contract may be satisfied by the inclusion in the resolution of
5 intention of the name of the coordinating utility. The ~~fifteen day~~
6 FIFTEEN-DAY period for filing notice of objections under section 48-584,
7 subsection E shall begin ~~upon~~ ON completion of publication and posting of
8 the notice of proposed improvement stating the name of the coordinating
9 utility.

10 F. The governing body shall determine the boundaries of the
11 district and designate the transmission facilities and, if applicable, any
12 independent parallel facilities, to be placed underground and shall obtain
13 from the coordinating utility an accurate statement of the costs of the
14 project, including an estimate of the average cost in assessments on an
15 average single family residence in the district. The amount shall be
16 included in the engineer's estimate required by section 48-577. The costs
17 shall include:

18 1. The amount by which the cost of placing facilities underground
19 would exceed the cost of placing comparable facilities overhead.

20 2. The reconstruction cost and net depreciation costs of any
21 existing facilities to be removed.

22 3. The actual costs of removing such existing facilities, less the
23 salvage value of the facilities removed.

24 4. The charge to finance the costs prescribed in this subsection
25 over a stated period of not to exceed fifteen years.

26 5. The tax reimbursement amount.

27 G. On receipt of an accurate estimate of the costs of the project,
28 the governing body shall call a simplified ballot card election in the
29 area affected by the proposed district. The simplified ballot card shall
30 contain the words for a district formation election "district, yes" and
31 "district, no" and for an assessment election "assessment, yes" and
32 "assessment, no". A single simplified ballot card may be used for both
33 the question of the formation of the district and the question of the
34 assessment. The election may be conducted in a simplified format and
35 administered by the governing body. The governing body shall mail to all
36 registered voters and property owners within the proposed district
37 simplified ballot cards with return postage prepaid. The simplified
38 ballot card shall clearly state that to be valid a voted ballot card shall
39 be returned to the governing body within thirty days after the governing
40 body mails the ballot card and a ballot card that is not timely returned
41 shall not be counted. A person who is qualified to vote in a municipal
42 election for that municipality or a property owner who owns land within
43 the proposed improvement district ~~are~~ IS qualified to vote in an election
44 for a municipal improvement district formed pursuant to this section,
45 except that only residents of or property owners in the area that is

1 within the proposed district may vote. If a majority of the persons
2 voting with the simplified ballot card approves the formation of the
3 district and if a majority of the persons voting with the simplified
4 ballot card approves the assessment, the governing body may form the
5 district and make the assessment. If more than one governing body is
6 affected by a proposed district, each governing body may form its own
7 district for the portion of the work within its jurisdiction. Assessments
8 for districts that are formed for a portion of the same project shall be
9 distributed between districts in proportion to the benefits to be
10 received. When the governing body acquires jurisdiction to order the
11 work, it shall not call for construction bids but may enter into a
12 contract or contracts with the utility, utilities or licensed cable
13 television system whose facilities are to be placed underground. Prior to
14 entering into a contract or contracts the coordinating utility shall
15 submit a final report to the municipality. The amount stated in the final
16 report may be based on detailed engineering studies. If the amount stated
17 in the final report exceeds the amount stated in the preliminary report
18 the governing body may either:

- 19 1. Terminate the project.
- 20 2. Call a new election on the improvement.

21 H. The contract shall provide for payment to the utility or
22 licensed cable television system over a term of not to exceed fifteen
23 years of the amount set forth in the final report, shall specify those
24 facilities to be owned by the municipality and those to be owned by the
25 utility, utilities or licensed cable television system and shall contain
26 such provisions for the prepayment of any assessment at the option of any
27 property owner, and such other terms, covenants and conditions as the
28 governing body and the utility, utilities or licensed cable television
29 system determine. The licensed cable television system shall not be
30 entitled to reimbursement except where the cable television system's
31 parallel facilities are installed to replace existing cable television
32 facilities other than independent parallel facilities not included by the
33 governing body in the work. The amount payable on the contract or
34 contracts ~~shall be~~ IS payable solely from amounts collected on the
35 assessment levied in the district. ~~No~~ A payment or performance bond ~~shall~~
36 ~~be~~ IS NOT required of a utility or licensed cable television system
37 entering into a contract with the governing body.

38 I. The municipality may retain an independent engineering
39 consultant to review all reports, estimates and costs provided by the
40 coordinating utility.

41 J. The coordinating utility shall advance or reimburse a governing
42 body for the costs of forming the district and the cost of printing,
43 advertising and posting incurred or to be incurred by a governing body and
44 shall bear its own expenses for engineering and design, and preparing the
45 reports, plans and specifications. ~~Upon~~ ON completion of the work, the

1 coordinating utility shall reimburse a governing body for its reasonable
2 expenses incurred with respect to the district. Unless otherwise provided
3 for in a manner acceptable to the coordinating utility, the amounts
4 advanced or reimbursed shall be included in the contract and in the amount
5 assessed.

6 K. This section does not amend or modify any existing line
7 extension policies of any utility involved. The costs to be reimbursed
8 under the contract shall be reduced to the extent of amounts paid or to be
9 paid by landowners or from other sources directly to the utility or cable
10 television system for the installation of the facilities.

11 L. The assessment and warrant may be recorded at any time following
12 approval of the project at an election. The hearing on the assessment may
13 be held at any time not less than twenty days from the date of recording
14 of the assessment and warrant. An additional hearing following notice
15 from the superintendent of streets to the governing body of completion of
16 the work shall be requested only if any member of the governing body or
17 any owner of or any person claiming an interest in any lot ~~which~~ THAT
18 received an assessment, within one year of the date of the notice of
19 completion, files a written notice with the clerk stating that the work
20 has not been performed substantially in accordance with the resolution of
21 intention, the plans and specifications and estimate. The notice shall
22 state in particular the failure to perform and may also state, if
23 applicable, any requested reduction in the assessment of any one or more
24 parcels due solely to the failure of such performance. The notice shall
25 state the name and address of the person filing the notice and shall
26 describe such person's interest in land subject to assessment. The
27 governing body may enforce the contract and may recess the hearing to
28 permit the utility or licensed cable television system to complete the
29 work. If the work cannot be completed, the assessment may be adjusted to
30 take the failure to complete into consideration. The amount due under the
31 agreement with the utility or licensed cable television system shall be
32 adjusted accordingly. Repayment under the contract shall be conditioned
33 on completion of the work and approval of the assessment as provided by
34 law. Unless an objection has been filed, repayment shall begin within
35 nine months of the notice of completion.

36 M. An improvement district formed pursuant to this section shall
37 not issue bonds, and the assessment for district purposes against the
38 property within the district shall not exceed the amount specified in the
39 engineer's estimate. Notwithstanding any other statute, the assessment
40 for an underground electrical power line shall not be assessed against the
41 owners of the frontage of the right-of-way of the underground power line
42 but shall be assessed against all property owners benefiting from the
43 burial of the power line.

1 N. The governing body shall provide for the levy and collection of
2 assessments on the real property in the district in the manner provided
3 for in this article. However, the assessment may be paid in installments
4 necessary to pay amounts due under the contract and to reimburse the
5 municipality for expenses incurred as provided in the assessment.

6 O. A district formed under this section shall not engage in any
7 activity other than contracting for or establishing underground
8 transmission facilities together, where applicable, with parallel
9 facilities.

10 P. The governing body by resolution may summarily determine that it
11 will participate in the costs of the improvement. If the municipality is
12 willing to assume the total outstanding assessment for the underground
13 utility facilities, the governing body may summarily dissolve the district
14 by resolution after payment of all liabilities including all amounts due
15 under the contract.

16 Q. The formation of an improvement district for underground utility
17 facilities under this section does not prevent the establishment of other
18 improvement districts which may include all or part of the same property
19 for any purposes authorized by law.

20 R. If a petition for the formation of an improvement district for
21 underground utilities is presented to the governing body, and the petition
22 purports to be signed by all of the real property owners in the proposed
23 district exclusive of mortgagees and other lienholders, the governing
24 body, after verifying such ownership and making a finding of such fact,
25 may adopt a resolution of intention to order the proposed improvement
26 pursuant to section 48-576 and has immediate jurisdiction to adopt the
27 resolution ordering the improvement pursuant to section 48-581, without
28 the necessity of publication and posting of the resolution of intention
29 provided for in section 48-578.

30 S. If the governing body determines that a parcel of property is a
31 single family residence and that payment of the assessment would cause a
32 financial hardship on the owners which would be likely to cause a
33 delinquency in payment of the assessment, the assessment for an
34 improvement made under this section shall provide for an extension in the
35 time to pay principal and interest on the assessment against that parcel
36 for a period of time not to exceed ten years. If the governing body
37 determines that the grounds for extension no longer exist, then the
38 extension will be terminated and all payments ~~which~~ THAT would have been
39 due but for the extension shall become due. The assessment shall provide
40 for adjustments in the assessments against the remaining parcels to
41 provide for timely payment under the agreement.

42 T. Notice of the passage of a resolution of intention for an
43 improvement under this section shall be given to the corporation
44 commission and, where the improvement involves a utility regulated
45 thereby, the rural electrification administration.

1 U. In this section, unless the context otherwise requires:

2 1. "Coordinating utility" means the utility whose proposed or
3 existing transmission facilities are to be placed underground. The
4 coordinating utility is responsible for assembling into one report cost
5 estimates and other data provided by each utility or licensed cable
6 television system whose facilities are to be placed underground.

7 2. "Cost" means all costs of design and construction of facilities.

8 3. "Facilities" means any works or improvements used or useful in
9 providing electric, communications, ~~or~~ licensed cable television service
10 ~~OR VIDEO SERVICE~~, including ~~but not limited to~~ poles, supports, tunnels,
11 manholes, vaults, conduits, pipes, wires, conductors, guys, studs,
12 platforms, crossarms, braces, transformers, insulators, cutouts, switches,
13 capacitors, meters, communication circuits, appliances, attachments and
14 appurtenances but excluding any works for transmission by microwave or
15 radio. Facilities shall include only transmission facilities and parallel
16 facilities.

17 4. "Governing body" means the council of a city or town or the
18 board of supervisors of a county.

19 5. "Independent parallel facilities" means existing parallel
20 facilities ~~which~~ ~~THAT~~ do not rely for their support on poles or other
21 structures to be removed as part of the work. If the utility or licensed
22 cable television system elects to remove the independent parallel
23 facilities but the removal and underground replacement thereof was not
24 included by the governing body in the work, the reconstruction and removal
25 costs of such independent parallel facilities shall not be included in a
26 contract or be assessed.

27 6. "Parallel facilities" means facilities that run or are permitted
28 to run in the easement in which the transmission facilities are to be
29 placed underground and that may be included underground with the
30 transmission facilities, and facilities appurtenant thereto. Any parallel
31 facilities shall have a right to be included underground and have access
32 to a trench on such reasonable terms and conditions as the coordinating
33 utility and the owners of the parallel facility may determine provided
34 they do not interfere with the installation or operation of the
35 transmission facilities.

36 7. "Private parallel facilities" means parallel facilities other
37 than those owned or operated by a public utility or licensed cable
38 television system. Private parallel facilities have the rights of
39 parallel facilities except that the costs thereof shall not be included in
40 a contract or be assessed.

41 8. "Tax reimbursement" means an annual charge for reimbursement for
42 property taxes, or voluntary contributions in lieu of property taxes as
43 provided in chapter 1, article 8 of this title, by applying the tax rates
44 in effect on the date of adoption of the resolution of intention to the
45 amount by which the estimated average taxable value of underground

1 facilities, excluding the value of trenches, backfill and compaction, on
2 completion exceeds the estimated average taxable value of comparable
3 overhead facilities. In this paragraph, "estimated average taxable value"
4 means the average of the estimated taxable value for each year of
5 reimbursement. The value of the trenches, backfill and compaction of the
6 underground facilities shall be attributed to and shall inure to the
7 benefit of the owners of property within the district and shall be owned
8 by the city. Reimbursement shall not be for a period longer than fifteen
9 years.

10 9. "Transmission facilities" means facilities ~~which~~ THAT are, or
11 are appurtenant to, electric transmission lines of more than twenty-five
12 kilovolts but not more than two hundred thirty kilovolts in size.

13 Sec. 27. Section 48-5107, Arizona Revised Statutes, is amended to
14 read:

15 48-5107. Utility relocation reimbursement; definition

16 A. All costs for the relocation, and reasonable ongoing costs
17 related to the relocation, of utility facilities incurred after July 1,
18 2003 as a direct result of the construction and operation of a light rail
19 project shall be reimbursed by the light rail project to the utility. The
20 board shall make the payments from transportation excise tax revenues
21 allocated pursuant to section 48-5103, subsection A, paragraph 3,
22 subdivision (a) within ninety days after presentation of a statement of
23 verified expenses. The statement of verified expenses shall not include
24 profit but may include a reasonable allocation of general overhead. The
25 verified expenses may be reviewed and audited by the light rail operator,
26 but the audit must be concluded within ninety days and shall be conducted
27 pursuant to standard industry accounting principles.

28 B. If the relocated utility has existing land rights, the light
29 rail operator shall relocate the utility with equal land rights. If the
30 relocated utility is operating in the right-of-way under a permit, the
31 light rail operator shall relocate the utility according to the utility's
32 existing rights under the permit within the right-of-way.

33 C. The light rail operator shall be fully responsible for acts,
34 negligence or omissions of all of its employees on the project that result
35 in damage to utility facilities.

36 D. For the purposes of this section, "utility" means any public
37 service corporation, agricultural improvement district, licensed cable
38 television system, LICENSED VIDEO SERVICE NETWORK, telephone line or
39 telegraph line corporation or person engaged in the generation,
40 transmission or delivery of electricity, natural gas, telephone, cable
41 television, VIDEO, telegraph or water service, including this state or any
42 political subdivision or agency of this state.

1 Sec. 28. Section 48-5315, Arizona Revised Statutes, is amended to
2 read:

3 48-5315. Utility relocation reimbursement; definition

4 A. If county transportation excise tax monies collected pursuant to
5 section 42-6106 are used to construct a light rail system under the
6 regional transportation plan, all costs for the relocation, and reasonable
7 ongoing costs related to the relocation, of utility facilities incurred as
8 a direct result of the construction and operation of the light rail system
9 shall be reimbursed by the light rail project to the utility. The board
10 shall make the payments from transportation excise tax revenues within
11 ninety days after presentation of a statement of verified expenses. The
12 statement of verified expenses shall not include profit but may include a
13 reasonable allocation of general overhead. The verified expenses may be
14 reviewed and audited by the light rail operator. The audit must be
15 concluded within ninety days and shall be conducted pursuant to standard
16 industry accounting principles.

17 B. If the relocated utility has existing land rights, the light
18 rail operator shall relocate the utility with equal land rights. If the
19 relocated utility is operating in the right-of-way under a permit, the
20 light rail operator shall relocate the utility according to the utility's
21 existing rights under the permit within the right-of-way.

22 C. The light rail operator shall be fully responsible for acts,
23 negligence or omissions of all of its employees on the project that result
24 in damage to utility facilities.

25 D. For the purposes of this section, "utility" means any public
26 service corporation, licensed cable television system, **LICENSED VIDEO**
27 **SERVICE NETWORK**, telephone line or telegraph line corporation or person
28 engaged in the generation, transmission or delivery of electricity,
29 natural gas, telephone, cable television, **VIDEO**, telegraph or water
30 service, including this state or any political subdivision or agency of
31 this state.

32 Sec. 29. Conditional enactment

33 Section 42-6004, Arizona Revised Statutes, as amended by Laws 2018,
34 chapter 17, section 1, chapter 249, section 6, chapter 263, section 3,
35 chapter 341, section 2 and this act, becomes effective on the date
36 prescribed by Laws 2018, chapter 263, section 5 but only on the occurrence
37 of the condition prescribed by Laws 2018, chapter 263, section 5.

APPROVED BY THE GOVERNOR MAY 1, 2019.

FILED IN THE OFFICE OF THE SECRETARY OF STATE MAY 1, 2019.



AGENDA ITEM REVIEW FORM

Regular City Council Meeting

6.E.

Meeting Date: 05/22/2019

Department Head: Jose A. Guzman, Director of Planning & Zoning, Planning & Zoning Department

Submitted By: Jose A. Guzman, Director of Planning & Zoning, Planning & Zoning Department

Action Requested: Motion
Ordinance
Public Hearing

ITEM:

Public hearing followed by discussion and possible action on any and all matters regarding Rezoning Case No. 2019-0224 and Ordinance No. 390. An ordinance of the Mayor and City Council of the City of San Luis, Arizona, amending the official zoning map of the City of San Luis by changing the zoning classification of 30.3 acres from Medium-High Density Residential (R-2) to Medium Density Residential (R1-6) for property located on the northeast corner of County 24th Street and 20th Avenue. **(Jose A. Guzman, Director of Planning and Zoning)**

- A. Open public hearing
 - 1. Staff presentation
 - 2. Call to the Public on this item
- B. Close public hearing
- C. Approval of Reading of Ordinance No. 390 by title only
(City Clerk to read the ordinance by title only)
- D. Action on Ordinance No. 390

SUMMARY:

This is a request by Edais Engineering, Inc., on behalf of Riedel Holdings, LLC, owner, to rezone 30.3 acres from Medium-High Density Residential (R-2) to Medium Density Residential (R1-6). The subject property is located in the east mesa of the City of San Luis; at the northeast corner of County 24th and 20th Avenue (Assessor Parcel ID No. 227-10-009).

Bienestar 9A and Santa Cecilia 2 subdivisions are located to the west and are zoned Medium Density Residential (R1-6). Property to the east are zoned Medium-High Density Residential (R-2) and High-Density Residential (R-3) and is undeveloped land. Property to the south is zoned as Medium Density Residential (R-2) and Light Industrial (L-1) further south. Property to the north is part of Yuma County and is undeveloped land.

GENERAL PLAN:

This area is designated as Neighborhood in the City of San Luis 2020 General Plan. The activities proposed will be consistent with that designation (Chapter 2, Page 19-20). The Neighborhood Land Use designation allows all types of residential development.

AGENCY REVIEW:

As part of the review process, all land use cases are reviewed by various city and outside agencies. As required by State Statute staff sent notification letters to property owners within 300-feet of the proposed project (7 letters). The City has not received any significant concern or objection from the various review

agencies or adjacent property owners.

CITIZEN REVIEW MEETING:

As required by State Statute (A.R.S. §9-462.03) and City Code (§152.040(C)), a Citizen Review Meeting was held at City Hall on May 7, 2019.

The purpose of the Citizen Review Meeting is to provide adjacent landowners and other potentially affected citizens an opportunity to ask questions and express any issues or concerns that they may have with the proposed rezoning or specific plan application prior to the public hearing. There were no people from the public present.

PLANNING AND ZONING COMMISSION MEETING:

The Planning and Zoning Commission held a public hearing for this item during their regular meeting of May 14, 2019, at San Luis Council Chambers.

As previously mentioned, the current zoning is Medium-High Density Residential (R-2) and was approved by Ordinance No. 250 back in 2007. The rezoning was approved with conditions, one of the conditions was to have land dedicated and developed for parks and recreation purposes, at no cost to the City.

At the time of the Commission meeting, there was further analysis needed to be made in order to determine whether or not these conditions were applicable to the current zoning request. In case said conditions were applicable, staff recommended to the Commission approval of the Rezoning Case No. 2019-0224 with the condition that the applicant negotiated a development agreement with staff to address comments on Ordinance No. 250. If the conditions were not applicable staff would revise the recommended motion when presenting it to City Council.

ANALYSIS:

As an effort to alleviate the demand for bigger houses the City Council approved Ordinance No. 347, an ordinance to set up the minimum lot size to 6,000 sq. ft. for new subdivisions.

The reason for the rezoning request is that the property is zoned as Medium-High Density (R-2) which does not allow construction of single detached dwellings. The appropriate zoning for the construction of this subdivision is the requested, Medium Density Residential (R1-6) zoning district.

STAFF RECOMMENDATION:

After further analysis of Ordinance No. 250, it was determined that the conditions were not applicable to this rezoning and a development agreement was not required. Therefore, staff recommends approval of the rezoning request and approval and adoption of Ordinance No. 390.

RECOMMENDATION / SUGGESTED MOTION:

- 1. I MOVE TO APPROVE ORDINANCE NO. 390 BY TITLE ONLY.
(City Clerk to read Ordinance No. 390 by title only)**
- 2. I MOVE TO APPROVE ORDINANCE NO. 390 BY TITLE ONLY.**

N/A

Fiscal Impact

IS THERE FISCAL IMPACT ASSOCIATED WITH THIS ITEM:	N/A
CITY/STATE/FEDERAL FUNDS:	N/A
TOTAL:	N/A
BUDGETED AMOUNT:	N/A
AVAILABLE AMOUNT TO TRANSFER:	N/A

ACCT NAME & GL#/REMAINING BALANCE BEFORE PURCHASE: N/A

FISCAL IMPACT STATEMENT (IF THIS IS A BUDGET TRANSFER, YOU MUST ATTACH THE BUDGET ADJUSTMENT FORM):

N/A

Attachments

Ordinance No. 390

Location Map

Conceptual Plan

Aerial Picture

Ordinance No. 250



Ordinance

OFFICE OF THE
MAYOR
CITY OF SAN LUIS

No. 390

AN ORDINANCE OF THE MAYOR AND CITY COUNCIL OF THE CITY OF SAN LUIS, ARIZONA, AMENDING THE OFFICIAL ZONING MAP OF THE CITY OF SAN LUIS BY CHANGING THE ZONING CLASSIFICATION OF 30.3 ACRES FROM MEDIUM-HIGH DENSITY RESIDENTIAL (R-2) TO MEDIUM DENSITY RESIDENTIAL (R1-6) FOR PROPERTY LOCATED ON THE NORTHEAST CORNER OF COUNTY 24TH STREET AND 20TH AVENUE; REPEALING ANY CONFLICTING PROVISIONS; AND PROVIDING FOR SEVERABILITY

WHEREAS, the Mayor and City Council of the City of San Luis desire to amend the City of San Luis Official Zoning District Map (the "Zoning Map") pursuant to A.R.S. §9462.04 to change the zoning classification for 30.3 acres of real property located on Assessor Parcel ID # 227-10-009; and

WHEREAS, all due and proper notices of public hearings on the Zoning Map Amendment have been given and proper public hearings have been held, and a recommendation has been given regarding the Zoning Map Amendment by the Planning and Zoning Commission of the City of San Luis recommending approval of the change in zoning classification; as attached hereto as "Exhibit A"

BE IT ORDAINED by the Mayor and City Council of the City of San Luis, Arizona, as follows:

SECTION 1. That the above recitals are hereby incorporated as though fully set forth herein.

SECTION 2. That the Official Zoning Map of the City of San Luis is hereby amended in by changing the zoning classification of the Property more fully described as

The Southwest Quarter of the Southeast Quarter of Section 10, Township 11 South, Range 24 West of the Gila and Salt River Base and Meridian, Yuma County, Arizona.

EXCEPT the Southeast Quarter of the Southwest Quarter of the Southwest Quarter of the Southeast Quarter and the South half of the Southeast Quarter of the Southwest Quarter of the Southeast Quarter

of Section 10, Township 11 South, Range 24 West of the Gila and Salt River Base and Meridian, Yuma County, Arizona; and

EXCEPT the South 50 feet and the west 40 feet thereof; and

EXEPT 1/16th of all oil, gas, metals and mineral rights as reserved by the State of Arizona in Patent recorded in Docket 836, page 139, records of Yuma County, Arizona; and

EXEPT 1/8th of all remaining oil, gas, and other mineral other than materials which may be essential to the production of fissionable materials as reserved in instrument recorded in Docket 1483, page 18, records of Yuma County, Arizona

CONTAINING 30.30 ACRES MORE OR LESS.

SECTION 3. In the event of a conflict between the provisions of this ordinance and any other ordinance, resolution, regulation, or policy within the City of San Luis, the conflicting provisions are hereby repealed, superseded, and replaced, and the provisions of this ordinance shall govern.

SECTION 4. If any section, subsection, sentence, clause, phrase, or portion of this ordinance is for any reason held to be invalid or unconstitutional by the final decision of any court of competent jurisdiction, such decision shall not affect the validity of the remaining portions of this ordinance or said reference regulations.

PASSED AND ADOPTED by the Mayor and City Council of the City of San Luis, Arizona, this day of _____ 2019.

Gerardo Sanchez, Mayor

ATTEST:

APPROVED AS TO FORM:

Sonia Cornelio, City Clerk

Kay Marion Macuil, City Attorney

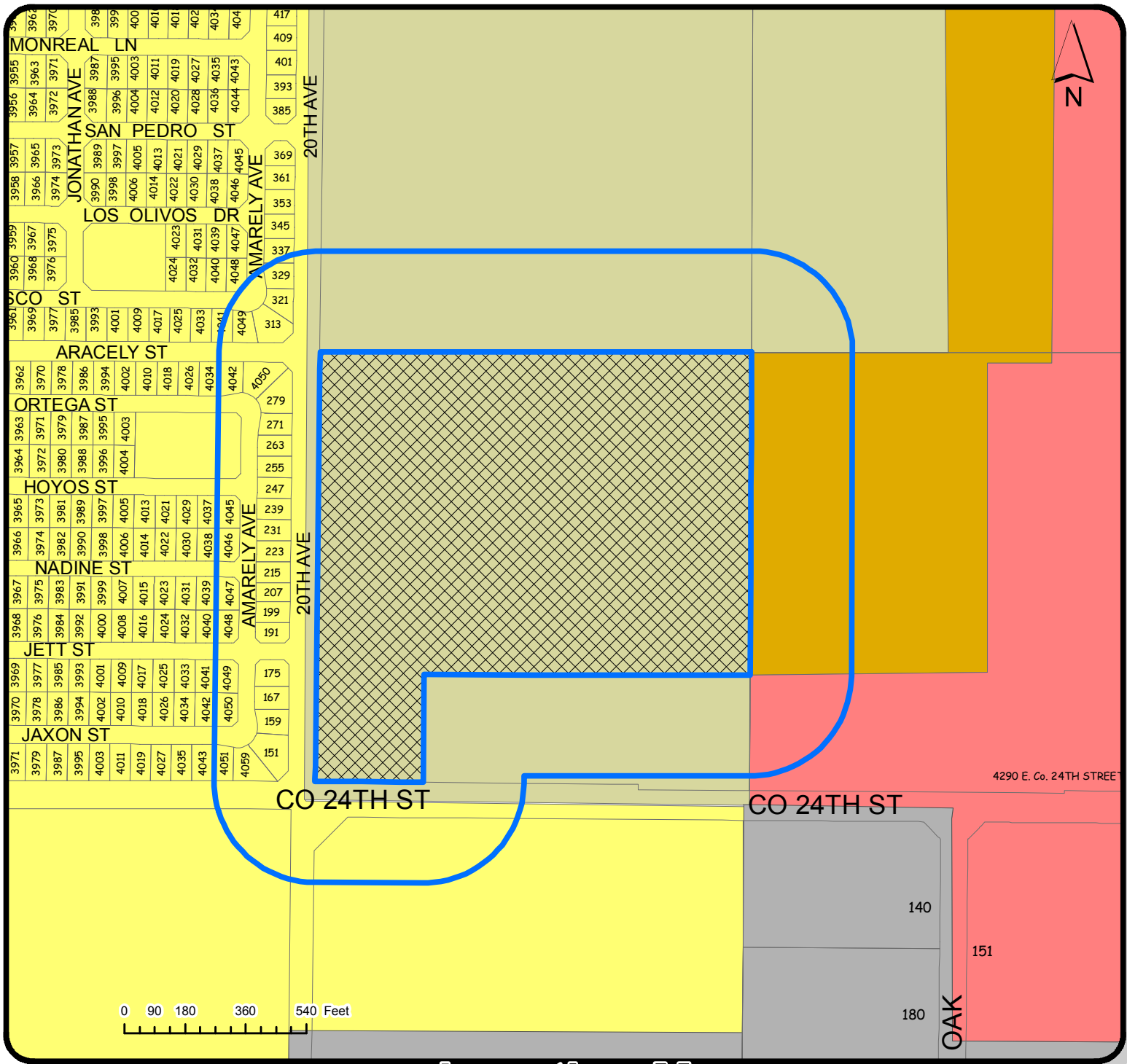

LOCATION OF SUBJECT PROPERTY





Location Map

REZONING

 AREA OF INTEREST TO BE REZONED:
APPROXIMATELY 30.30 ACRES
OF PARCEL 227-10-009

Zoning

REZONE FROM R-2 TO R1-6

-  MULTIPLE RESIDENCE ZONING DISTRICTS
R-3
-  INDUSTRIAL ZONING DISTRICTS
I-1
-  COMMERCIAL ZONING DISTRICTS
C-2
-  SINGLE RESIDENCE ZONING DISTRICTS
R1-8

 300ft Notification Area

Date:
4/24/2019

PLANNING & ZONING



GIS

Prepared By:
ISAAC GUTIERREZ

APPROVED BY:
JOSE A. GUZMAN

Case No.
2019-0224

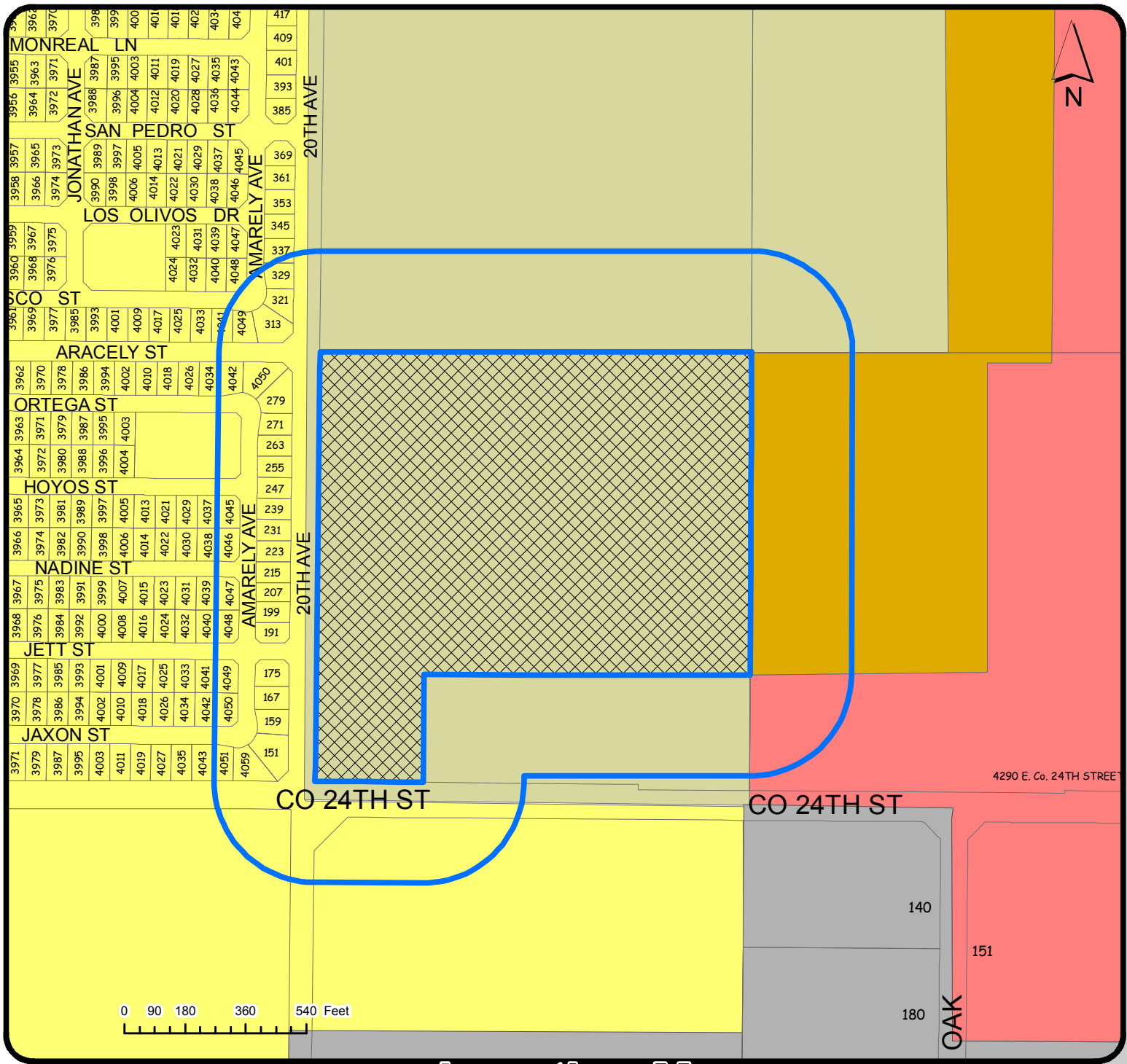

LOCATION OF SUBJECT PROPERTY





Location Map

REZONING

 AREA OF INTEREST TO BE REZONED:
APPROXIMATELY 30.30 ACRES
OF PARCEL 227-10-009

Zoning

REZONE FROM R-2 TO R1-6

-  MULTIPLE RESIDENCE ZONING DISTRICTS
R-3
-  INDUSTRIAL ZONING DISTRICTS
I-1
-  COMMERCIAL ZONING DISTRICTS
C-2
-  SINGLE RESIDENCE ZONING DISTRICTS
R1-8

 300ft Notification Area

Date:
4/24/2019

PLANNING & ZONING



GIS

Prepared By:
ISAAC GUTIERREZ

APPROVED BY:
JOSE A. GUZMAN

Case No.
2019-0224

SANTA CECILIA No. 3 SUBDIVISION

LOT 3 OF BORDER RANCHES SUBDIVISION AS RECORDED IN BOOK 27 OF PLATS, PAGES 9-10,
YUMA COUNTY RECORDERS OFFICE, YUMA COUNTY, ARIZONA

DATE OF PREPARATION: AUGUST 2018

NUMBER OF LOTS: 141

ACREAGE: 30.30 ACRES

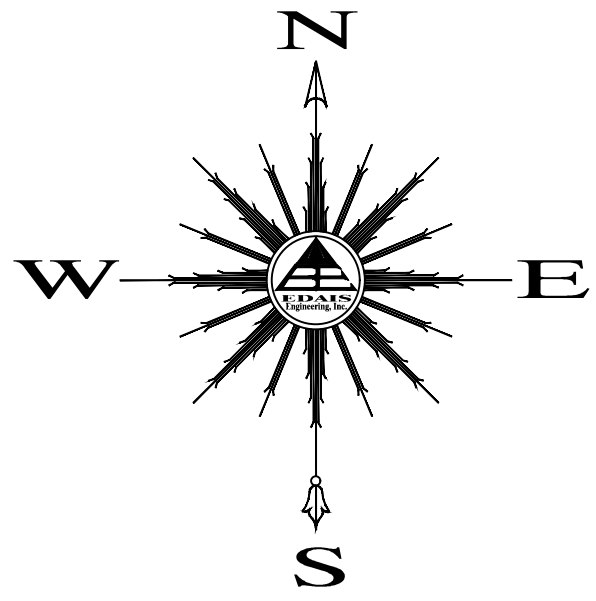

SCALE: 1" = 100'

LINE DATA

LINE	LENGTH	BEARING
L1	21.22	N45°01'59"W
L2	21.20	N44°58'01"E
L3	21.20	S44°58'01"W
L4	21.22	N45°02'15"W
L5	21.20	N44°57'45"E

CURVE DATA

CURVE	DELTA	CHORD DIRECTION	CHORD	TANGENT	RADIUS	LENGTH
C1	243°13'39"	N58°19'51"E	94.53'	-90.17'	55.50'	235.60'
C2	243°13'39"	N58°19'51"E	94.53'	-90.17'	55.50'	235.60'
C3	063°13'39"	S31°40'09"E	58.19'	34.16'	55.50'	61.25'

AREAS

LOT	AREA	LOT	AREA	LOT	AREA	LOT	AREA	LOT	AREA	LOT	AREA	LOT	AREA	LOT	AREA
332	6275.00 SF	351	9196.90 SF	370	6325.11 SF	388	6253.39 SF	406	6253.39 SF	424	6253.39 SF	442	6253.39 SF	460	6267.32 SF
333	6491.98 SF	352	8413.15 SF	371	6256.36 SF	389	6253.39 SF	407	6253.39 SF	425	6253.39 SF	443	6253.39 SF	461	6475.01 SF
334	6484.00 SF	353	8413.03 SF	372	6253.39 SF	390	6253.39 SF	408	6253.39 SF	426	6253.39 SF	444	6325.10 SF	462	6478.72 SF
335	6484.00 SF	355	6325.10 SF	373	6253.39 SF	391	6253.39 SF	409	6253.39 SF	427	6253.39 SF	445	6215.19 SF	463	6479.41 SF
336	6484.00 SF	356	6253.39 SF	374	6253.39 SF	392	6253.39 SF	410	6253.39 SF	428	6256.36 SF	446	6255.90 SF	464	6480.09 SF
337	6484.00 SF	357	6253.39 SF	375	6253.39 SF	393	6253.39 SF	411	6253.39 SF	429	6325.10 SF	447	6255.90 SF	465	6480.78 SF
338	6484.00 SF	358	6253.39 SF	376	6253.39 SF	394	6253.39 SF	412	6253.39 SF	430	6325.10 SF	448	6255.90 SF	466	6481.47 SF
339	6484.00 SF	359	6253.39 SF	377	6253.39 SF	395	6253.39 SF	413	6253.39 SF	431	6256.36 SF	449	6255.90 SF	467	6482.16 SF
340	6484.00 SF	360	6253.39 SF	378	6253.39 SF	396	6253.39 SF	414	6325.10 SF	432	6253.39 SF	450	6255.90 SF	468	6482.85 SF
341	6484.00 SF	361	6253.39 SF	379	6253.39 SF	397	6253.39 SF	415	6325.10 SF	433	6253.39 SF	451	6255.90 SF	469	6483.54 SF
342	6484.00 SF	362	6253.39 SF	380	6253.39 SF	398	6256.36 SF	416	6253.39 SF	434	6253.39 SF	452	6255.90 SF	470	6484.22 SF
343	6484.00 SF	363	6253.38 SF	381	6253.39 SF	399	6323.09 SF	417	6253.39 SF	435	6253.39 SF	453	6255.90 SF	471	6484.91 SF
344	6275.00 SF	364	6253.38 SF	382	6253.39 SF	400	6324.50 SF	418	6253.39 SF	436	6253.39 SF	454	6255.90 SF	472	6275.60 SF
345	6275.00 SF	365	6253.38 SF	383	6253.39 SF	401	6256.36 SF	419	6253.39 SF	437	6253.39 SF	455	6255.90 SF		
346	6000.00 SF	366	6253.38 SF	384	6325.10 SF	402	6253.39 SF	420	6253.39 SF	438	6253.39 SF	456	6255.90 SF		
347	6000.00 SF	367	6253.38 SF	385	6325.10 SF	403	6253.39 SF	421	6253.39 SF	439	6253.39 SF	457	6255.90 SF		
348	6000.00 SF	368	6256.35 SF	386	6253.39 SF	404	6253.39 SF	422	6253.39 SF	440	6253.39 SF	458	6258.87 SF		
349	10866.16 SF	369	6325.10 SF	387	6253.39 SF	405	6253.39 SF	423	6253.39 SF	441	6253.39 SF	459	6215.19 SF		

LEGEND

- CENTERLINE
- RIGHT-OF-WAY (ROW) LINE
- NEW PROPERTY LINE
- EASEMENT (TYPE AS NOTED)
- BOUNDARY LINE
- NEW STREET MONUMENT AS PER YUMA COUNTY STD. DETAIL NO. 4-080
- NEW SUBDIVISION BOUNDARY MONUMENT AS PER YUMA COUNTY STD. DETAIL NO. 04-030
- EXISTING MONUMENT (TYPE AS SHOWN)
- ① NEW LOT NUMBER
- ④ EXISTING LOT NUMBER
- A . P . N ASSESSOR PARCEL NUMBER
- B.C. BRASS CAP
- H.H. HAND HOLE
- Y.C.R. YUMA COUNTY RECORDS
- G. & S.R.B. & M. GILA AND SALT RIVER BASE AND MERIDIAN

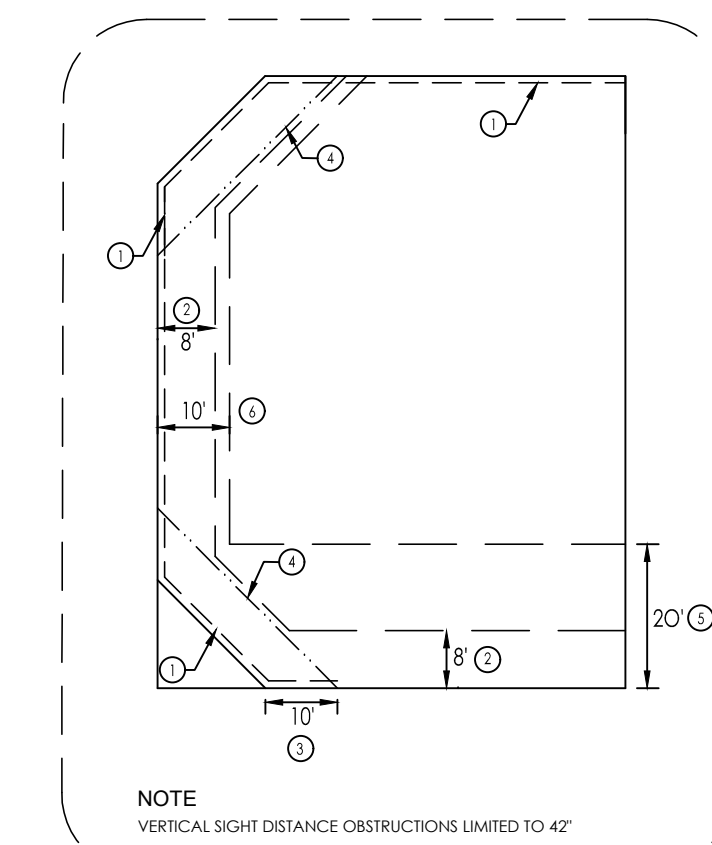

TYPICAL CORNER LOT DETAIL

LOCATION MAP

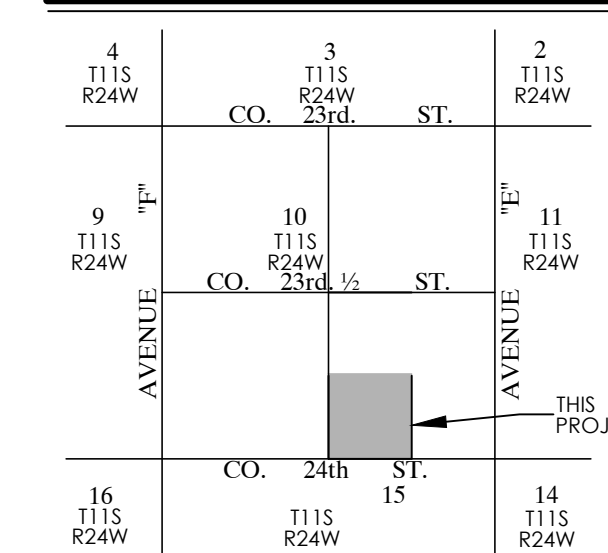

TRACT AREAS OWNER

TRACT	AREA
"A"	1.52 ACRES

R&G ASSOCIATES LLC.
P.O. BOX 1649
SAN LUIS, AZ 85349
(928) 627-9385

BASIS OF BEARING

THE WEST LINE OF THE SW 1/4 OF SECTION 10, T11S, R24W, G.S.R.B.&M., YUMA COUNTY, ARIZONA (BEING THE CENTERLINE OF AVENUE "F"), AS SHOWN ON BORDER RANCHES SUBDIVISION, AS RECORDED IN BOOK 27 OF PLATS, PAGES 9&10, YUMA COUNTY RECORDERS OFFICE, YUMA COUNTY, ARIZONA, NAMELY BEARING N00°02'42"W

SURVEYOR'S CERTIFICATE

I HEREBY CERTIFY THAT I AM A LAND SURVEYOR LISTED ON THE ROSTER OF ACTIVE REGISTRANTS BY THE STATE BOARD OF TECHNICAL REGISTRATION OF ARIZONA AND THAT THIS MAP CONSISTING OF ONE (1) SHEET CORRECTLY REPRESENTS A SURVEY MADE UNDER MY SUPERVISION, THAT ALL MONUMENTS SHOWN HEREON ACTUALLY EXIST AND THEIR POSITIONS ARE CORRECTLY SHOWN.

PREPARED BY:

Edais Engineering, Inc.
3075 S. AVENUE 4 E
YUMA, ARIZONA 85365
(928) 344-3566

**PRELIMINARY
NOT FOR
CONSTRUCTION**

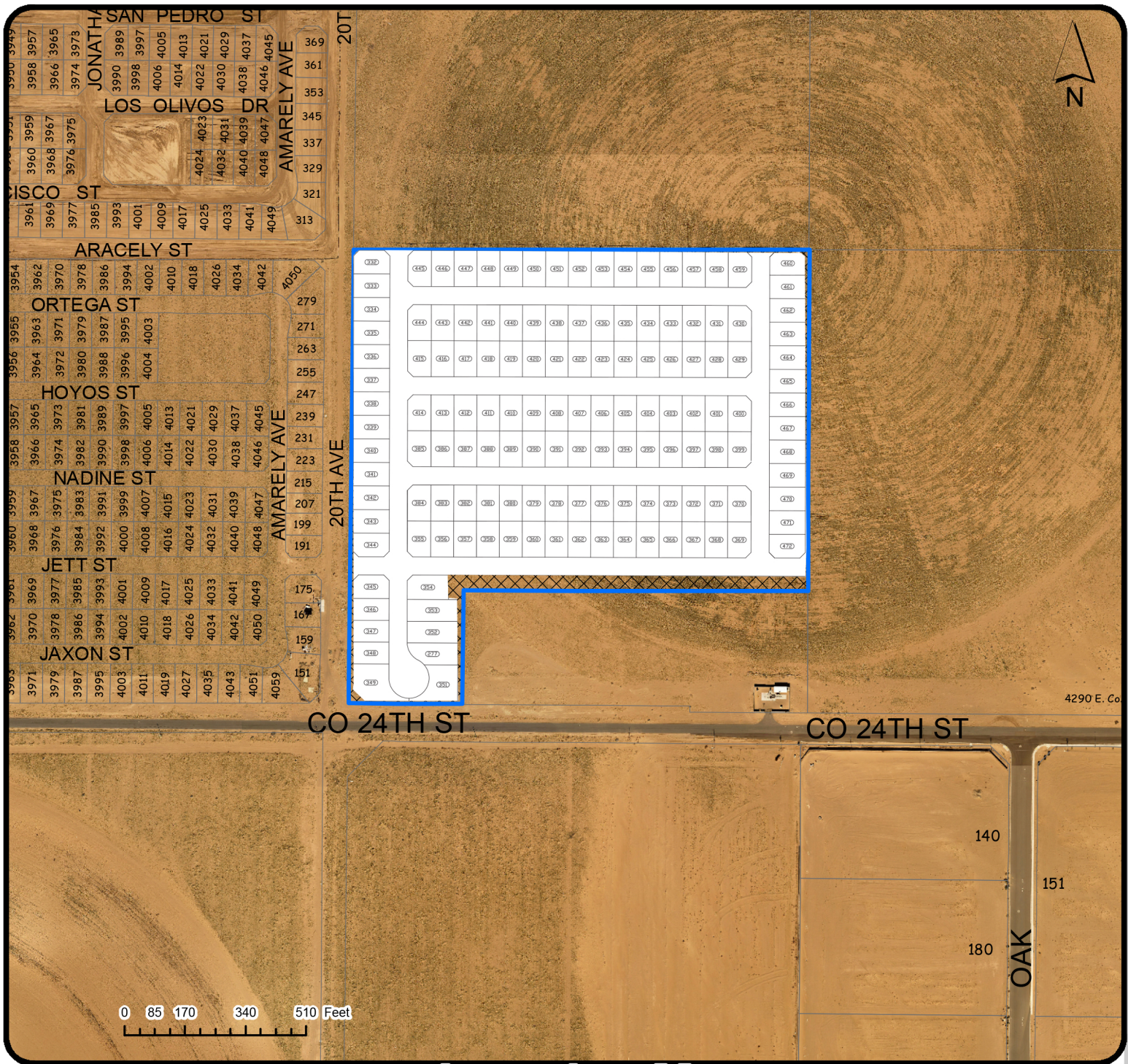

LOCATION OF SUBJECT PROPERTY

Location Map

REZONING

 PARCEL 227-10-009
Santa Cecilia 3 Conceptual Aerial

Date:
5/16/2019

Checked By:
ROMAN PACHECO

PLANNING & ZONING



INC. 1979

GIS

Prepared By:
ISAAC GUTIERREZ

APPROVED BY:
JOSE A. GUZMAN

Case No.
2019-0224

WHEN RECORDED MAIL TO:
CITY OF SAN LUIS
P.O. BOX 1170
SAN LUIS, AZ 85349
ATTN: CITY CLERK

OFFICIAL RECORDS OF
YUMA COUNTY RECORDER
SUSAN MARLER



FEE #: 2007 – 16715

05/07/2007 10:08 PAGES: 0004
FEES: 3.00 4.00 1.00 .00 .00
REQ BY: CITY OF SAN LUIS
REC BY: PATTY MAGANA

COPY
AS TO FILING DATA ONLY

The above area is to be reserved for recording information

C A P T I O N H E A D I N G :

Ordinance No. 250



Ordinance

ORDINANCE NO. 250

OFFICE OF THE
MAYOR
CITY OF SAN LUIS

AN ORDINANCE OF THE MAYOR AND CITY COUNCIL OF THE CITY OF SAN LUIS, ARIZONA, AMENDING ORDINANCE NO. 13, AS AMENDED, REZONING 280 ACRES LOCATED AT THE NORTH-EAST CORNER OF AVENUE 'F' AND COUNTY 24TH STREET FROM COUNTY RURAL AREA TEN (10) ACRE PARCELS (RA-10) TO INTERMEDIATE DENSITY RESIDENTIAL (R-2) ON 257.5 ACRES, TO HIGH DENSITY RESIDENTIAL (R-3) ON 10 ACRES AND TO GENERAL COMMERCIAL (C-2) ON 12.5 ACRES, AND AMENDING THE ZONING MAP TO CONFORM THERETO.

BE IT ORDAINED BY THE MAYOR AND COUNCIL OF THE CITY OF SAN LUIS, ARIZONA, AS FOLLOWS:

Section 1: That Ordinance #13, as amended, be further amended that the real property described as follows:

The southwest quarter of section 10 except the south 330 feet of the west 330 feet.

The southeast quarter of section 10 except the southeast quarter of the southeast quarter and except the east half of the north-east quarter of the southeast quarter of said section 10.

Said section 10 being in Township 11 South, Range 24 West of the Gila and Salt River Base and Meridian. Yuma County, Arizona.

Be rezoned from County RA-10 to Intermediate Density Residential (R-2) as defined in Ordinance #13, as amended, and upon this ordinance taking effect, shall be subject to all rules, regulations and requirements of the R-2 Zoning District of Ordinance #13, as amended.

Section 2: That Ordinance #13, as amended, be further amended that the real property described as follows:

The west half of the east half of the northeast quarter of the southeast quarter of Section 10, Township 11 South, Range 24 West of the Gila and Salt River Base and Meridian. Yuma County, Arizona.

Be rezoned from County RA-10 to High Density Residential (R-3) as defined in Ordinance #13, as amended, and upon this ordinance taking effect, shall be subject to all rules, regulations and requirements of the R-3 Zoning District of Ordinance #13, as amended.

Section 3: That Ordinance #13, as amended, be further amended that the real property described as follows:

The south 330 feet of the west 330 feet of the southwest quarter and the east half of the east half of the northeast quarter of the southeast quarter of Section 10, Township 11 South, Range 24 West of the Gila and Salt River Base and Meridian. Yuma County, Arizona.

Be rezoned from County RA-10 to General Commercial (C-2) as defined in Ordinance #13, as amended, and upon this ordinance taking effect, shall be subject to all rules, regulations, and requirements of the C-2 Zoning District of Ordinance #13, as amended.

Section 4: Adoption of this ordinance will include the following conditions:

1. Dedication of an additional seventeen feet of street right-of-way along County 24th Street.
2. Dedication of an additional seventeen feet of street right-of-way along Avenue 'F'
3. Dedication of forty (40) feet of street right-of-way along County 23 ½ Street.
4. All off-site improvements noted in the "Joint Development Agreement" made on the 16th day of March 2007 between the Comite de Bienestar, Border Ranches LLC and Sam Group to be constructed.
5. That land be dedicated and developed throughout the property being rezoned for parks and recreation purposes, at no cost to the City. These dedications shall be made at the discretion of the city and approved at the time of subdivision plat approval. The amount acreage dedicated shall not be less than a total of 12 nor more than 15 acres. Said land may be used for water/drainage retention purposes.
6. That the property be developed and all of the conditions met within 5 years of the effective date of this ordinance or the zoning will revert to the present previous zoning classification.

Section 5: That the zoning map adopted under said Ordinance #13, as amended is hereby ordered to be changed so as to show that said real property described in this ordinance is located within the zoning district herein provided.

PASSED AND ADOPTED by the Mayor and City Council of the City of San Luis,
Arizona, this 25th day of April, 2007.



Juan Carlos Escamilla, Mayor

ATTEST:

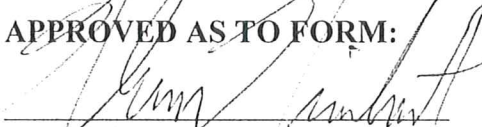

Sonia Sanchez, City Clerk

APPROVED AS TO FORM:



Glenn Gimbut, City Attorney