



PLANNING & ZONING AGENDA ITEM REVIEW FORM

Planning & Zoning Commission Meeting

4.C.

Meeting Date: 10/09/2018

Submitted By: Jose A. Guzman, Director of Planning & Zoning, Planning & Zoning Department

ITEM:

Public hearing followed by discussion and possible action on any and all matters regarding Rezoning Case No. 2018-0321. A request by Riedel Holdings LLC on behalf of Border Ranches AZ LLC, owner, to rezone 67.06 acres, located on the northeast corner of County 24th Street and 20th Avenue, from Medium-High Density Residential (R-2) to Medium Density Residential (R1-6).

- A. Open public hearing
 - 1. Staff presentation
 - 2. Call to the Public on this item
- B. Close public hearing
- C. Action on Rezoning Case No. 2018-0321

BACKGROUND:

The subject property is located in the east mesa of the City of San Luis; at the northeast corner of County 24th and 20th Avenue (Assessor Parcel ID No. 227-10-009). Bienestar 9A and Santa Cecilia 2 subdivisions are located to the west and are zoned Medium Density Residential (R1-6). Property to the east are zoned Medium-High Density Residential (R-2) and High Density Residential (R-3) and is undeveloped land. Property to the south is zoned as Medium Density Residential (R-2) and Light Industrial (L-I) further south. Property to the north is part of Yuma County and is undeveloped land.

GENERAL PLAN:

This area is designated as Neighborhood in the City of San Luis 2020 General Plan. The activities proposed will be consistent with that designation (Chapter 2, Page 19-20). The Neighborhood Land Use designation allows all types of residential development.

AGENCY REVIEW:

As part of the review process, all land use cases are reviewed by various City and outside agencies. We have received comments from the following agencies:

- 1. City of San Luis Fire Department
- 2. Yuma County Airport Authority

As required by State Statute staff sent notification letters to property owners within 300 feet of the proposed project(61 letters). The City has not received any other significant concern or objection from the various review agencies or adjacent property owners.

CITIZEN REVIEW MEETING:

As required by State Statute (A.R.S. §9-462.03) and City Code (§152.040(C)), a Citizen Review meeting was held at City Hall on October 2, 2018.

The purpose of the Citizen Review Meeting is to provide adjacent landowners and other potentially affected citizens an opportunity to ask questions and express any issues or concerns that they may have

with the proposed rezoning or specific plan application prior to the public hearing. There were no people from the public present.

ANALYSIS:

As an effort to alleviate the demand for bigger houses the City Council approved Ordinance No. 347, an ordinance to set up the minimum lot size to 6,000 sq. ft. for new subdivisions.

The reason for the rezoning request is that the property is zoned as Medium-High Density (R-2) which does not allow construction of single detached dwellings. The appropriate zoning for the construction of this subdivision is the requested, Medium Density Residential (R1-6) zoning district.

SUMMARY:

As mentioned above, the current zoning is Medium-High Density Residential (R-2) and was approved by Ordinance No. 250 back in 2007. The rezoning was approved with conditions, one of the conditions was to have land dedicated and developed for parks and recreation purposes, at no cost to the City.

Staff recommendation is to recommend approval of the request with the condition that the developer negotiates a development agreement with staff to address conditions of Ordinance No. 250.

RECOMMENDED MOTION:

I MOVE TO FORWARD REZONING CASE NO. 2018-0321 TO THE CITY COUNCIL, WITH AN APPROVAL RECOMMENDATION SUBJECT TO THE CONDITION THAT THE DEVELOPER NEGOTIATES A DEVELOPMENT AGREEMENT WITH STAFF.

Attachments

Location Map
Aerial Picture
Conceptual Plan
Ordinance No. 250
San Luis Fire Department comments
Yuma County Airport Authority

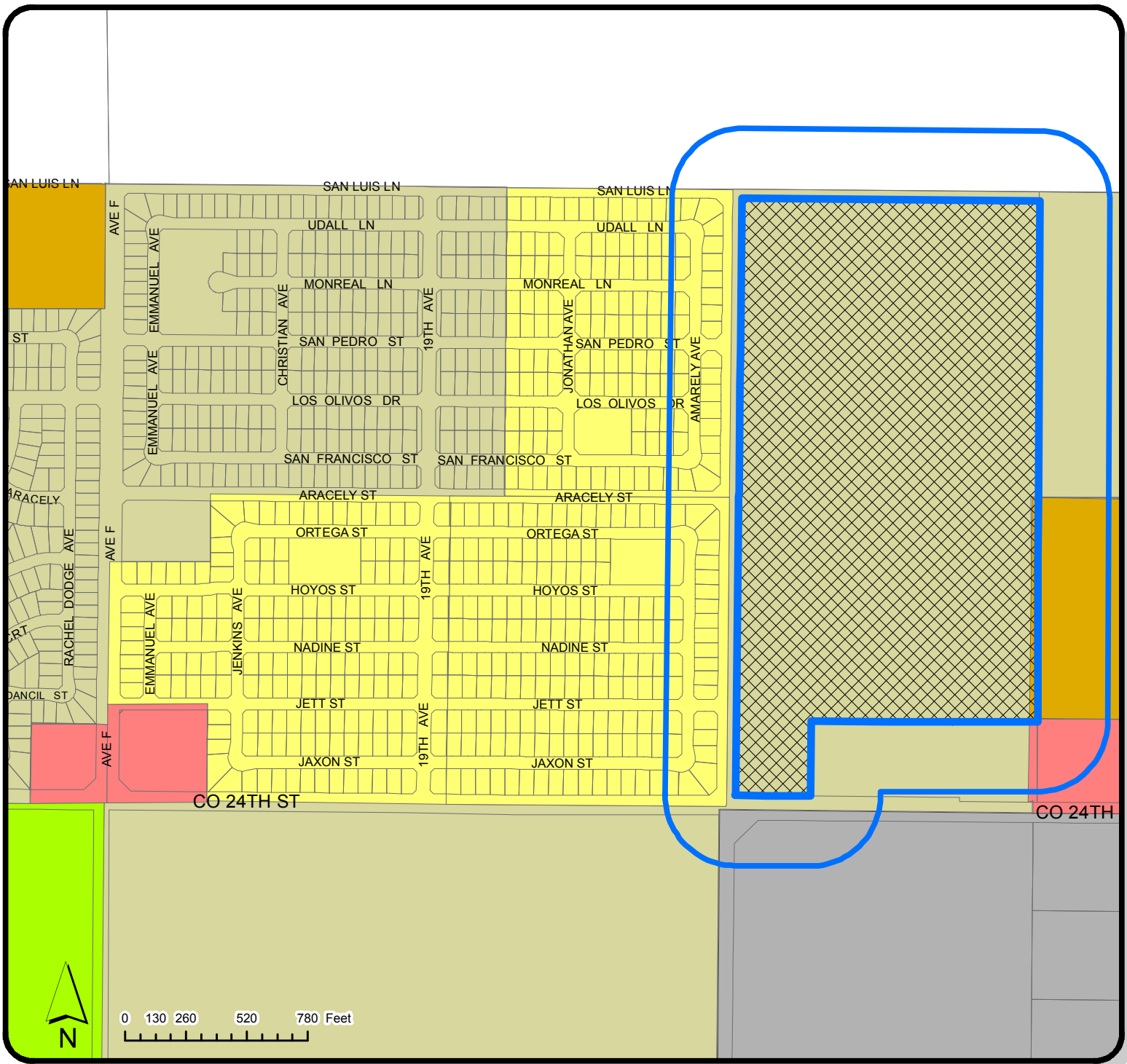

Location Map

REZONING

REZONE FROM R-2 to R1-6



The subject property address/location: North-west corner of County 24th and 20th Avenue; Assessor's Parcel No. 227-10-009 (approximately 67.06 acres). This is a request to rezone 67.06 acres from R -2 to R1-6.

Legend

- MULTIPLE RESIDENCE ZONING DISTRICTS
 - R-2
 - R-3
- INDUSTRIAL ZONING DISTRICTS
 - I
- COMMERCIAL ZONING DISTRICTS
 - C-2
- SINGLE RESIDENCE ZONING DISTRICTS
 - RA-10



300ft Notification Area

Date:

9/13/2018

Checked By:

ROMAN PACHECO



GIS DIVISION

Prepared By:

IG

APPROVED BY:

JOSE A. GUZMAN

Case No.

2018-0458

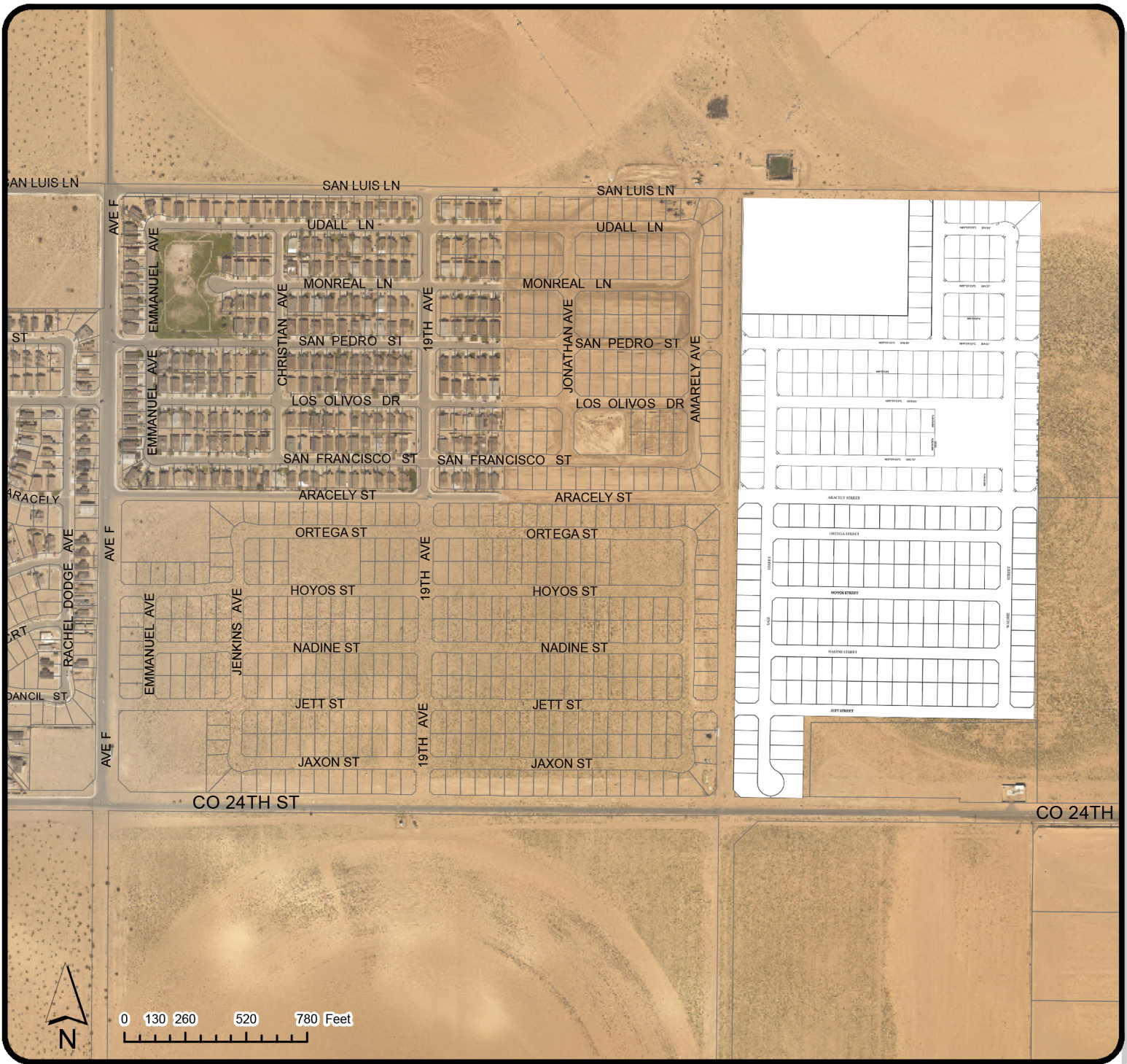

Location Map

REZONING



The subject property address/location: North-west corner of County 24th and 20th Avenue; Assessor's Parcel No. 227-10-009 (approximately 67.06 acres). This is a request to rezone 67.06 acres from R-2 to R1-6. Please include location of subject property, zoning legend, north arrow, scale on map, case #, 300 ft. buffer, and all necessary details.



300ft Notification Area

Date:

9/13/2018

Checked By:

ROMAN PACHECO



GIS DIVISION

Prepared By:

IG

APPROVED BY:

JOSE A. GUZMAN

Case No.

2018-0458

SANTA CECILIA No. 3 SUBDIVISION

LOT 3 OF BORDER RANCHES SUBDIVISION AS RECORDED IN BOOK 27 OF PLATS, PAGES 9-10,
YUMA COUNTY RECORDERS OFFICE, YUMA COUNTY, ARIZONA

DATE OF PREPARATION: AUGUST 2018 NUMBER OF LOTS: 141 ACREAGE: 30.30 ACRES

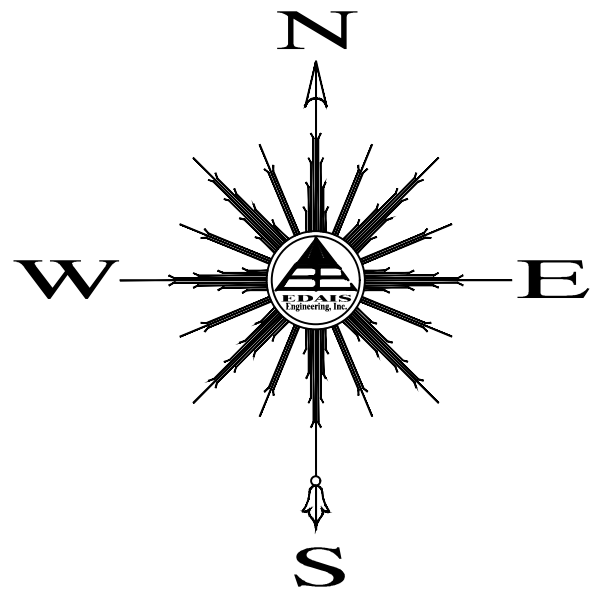

SCALE: 1" = 100'

LINE DATA

LINE	LENGTH	BEARING
L1	21.20'	N44°58'01"E
L2	21.22'	N45°01'59"W
L3	21.22'	S45°01'59"E
L4	21.20'	S44°57'45"W
L5	21.22'	S45°02'15"E
L6	42.44'	S45°02'03"E
L7	42.41'	S44°58'01"W

CURVE DATA

CURVE	DELTA	CHORD DIRECTION	CHORD	TANGENT	RADIUS	LENGTH
C1	062°44'13"	S31°54'52"E	57.78'	33.84'	55.50'	60.77'
C2	134°03'09"	N22°55'06"E	102.20'	130.92'	55.50'	129.85'
C3	090°00'00"	S45°03'20"E	78.49'	55.50'	55.50'	87.18'

AREAS

LOT	AREA	LOT	AREA	LOT	AREA	LOT	AREA	LOT	AREA	LOT	AREA	LOT	AREA
332	5937.50 SF	352	8413.19 SF	372	6253.39 SF	392	6253.39 SF	412	6253.39 SF	432	6253.39 SF	452	6255.90 SF
333	6491.98 SF	353	8413.03 SF	373	6253.39 SF	393	6253.39 SF	413	6253.39 SF	433	6253.39 SF	453	6255.90 SF
334	6484.00 SF	354	9001.44 SF	374	6253.39 SF	394	6253.39 SF	414	6325.10 SF	434	6253.39 SF	454	6255.90 SF
335	6484.00 SF	355	6325.10 SF	375	6253.39 SF	395	6253.39 SF	415	6325.10 SF	435	6253.39 SF	455	6255.90 SF
336	6484.00 SF	356	6253.39 SF	376	6253.39 SF	396	6253.39 SF	416	6253.39 SF	436	6253.39 SF	456	6255.90 SF
337	6484.00 SF	357	6253.39 SF	377	6253.39 SF	397	6253.39 SF	417	6253.39 SF	437	6253.39 SF	457	6255.90 SF
338	6484.00 SF	358	6253.39 SF	378	6253.39 SF	398	6252.97 SF	418	6253.39 SF	438	6253.39 SF	458	6247.44 SF
339	6484.00 SF	359	6253.39 SF	379	6253.39 SF	399	6325.10 SF	419	6253.39 SF	439	6253.39 SF	459	6215.19 SF
340	6484.00 SF	360	6253.39 SF	380	6253.39 SF	400	6325.10 SF	420	6253.39 SF	440	6253.39 SF	460	6275.00 SF
341	6484.00 SF	361	6253.38 SF	381	6253.39 SF	401	6251.37 SF	421	6253.39 SF	441	6253.39 SF	461	6481.98 SF
342	6484.00 SF	362	6253.38 SF	382	6253.39 SF	402	6253.39 SF	422	6253.39 SF	442	6253.39 SF	462	6485.00 SF
343	6484.00 SF	363	6253.38 SF	383	6253.39 SF	403	6253.39 SF	423	6253.39 SF	443	6253.39 SF	463	6485.00 SF
344	6275.00 SF	364	6253.38 SF	384	6325.10 SF	404	6253.39 SF	424	6253.39 SF	444	6325.10 SF	464	6485.00 SF
345	6274.94 SF	365	6253.38 SF	385	6325.10 SF	405	6253.39 SF	425	6253.39 SF	445	6215.19 SF	465	6485.00 SF
346	5999.77 SF	366	6253.38 SF	386	6253.39 SF	406	6253.39 SF	426	6253.39 SF	446	6253.39 SF	466	6485.00 SF
347	5999.60 SF	367	6253.38 SF	387	6253.39 SF	407	6253.39 SF	427	6253.39 SF	447	6253.39 SF	467	6485.00 SF
348	5999.42 SF	368	6256.99 SF	388	6253.39 SF	408	6253.39 SF	428	6248.95 SF	448	6255.90 SF	468	6485.00 SF
349	10865.42 SF	369	6325.10 SF	389	6253.39 SF	409	6253.39 SF	429	6325.10 SF	449	6255.90 SF	469	6485.00 SF
350	9384.52 SF	370	6325.11 SF	390	6253.39 SF	410	6253.39 SF	430	6325.10 SF	450	6255.90 SF	470	6485.00 SF
351	7557.60 SF	371	6255.40 SF	391	6253.39 SF	411	6253.39 SF	431	6247.35 SF	451	6255.90 SF	471	6485.00 SF

LEGEND

- CENTERLINE
- RIGHT-OF-WAY (ROW) LINE
- NEW PROPERTY LINE
- EASEMENT (TYPE AS NOTED)
- BOUNDARY LINE
- NEW STREET MONUMENT AS PER YUMA COUNTY STD. DETAIL No. 4-080
- NEW SUBDIVISION BOUNDARY MONUMENT AS PER YUMA COUNTY STD. DETAIL No. 04-030
- EXISTING MONUMENT (TYPE AS SHOWN)
- ① NEW LOT NUMBER
- ④7 EXISTING LOT NUMBER
- A . P . N ASSESSOR PARCEL NUMBER
- B.C. BRASS CAP
- H.H. HAND HOLE
- Y.C.R. YUMA COUNTY RECORDS
- G. & S.R.B. & M. GILA AND SALT RIVER BASE AND MERIDIAN

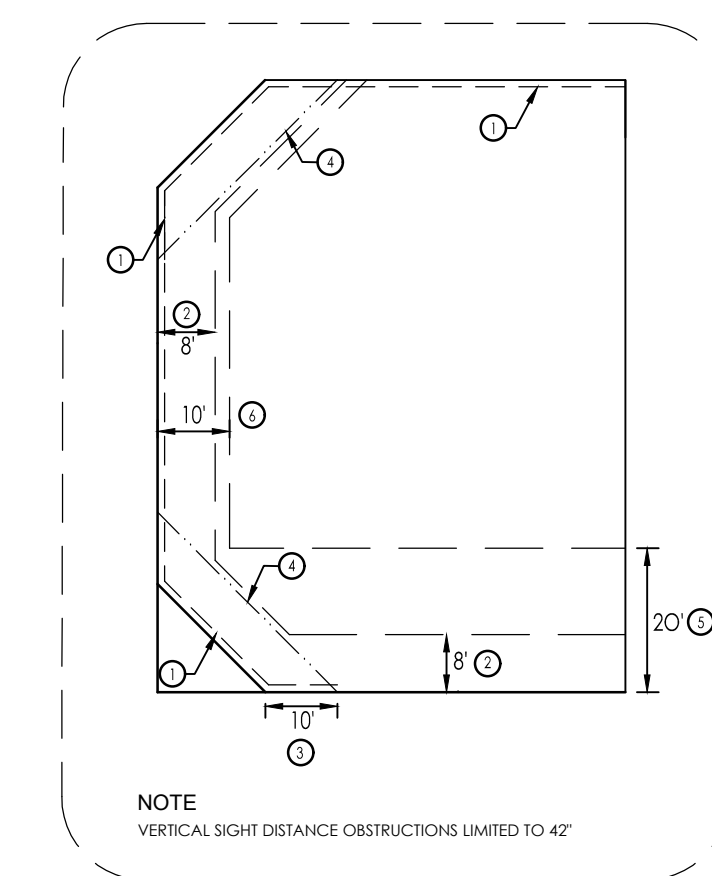

TYPICAL CORNER LOT DETAIL

LOCATION MAP

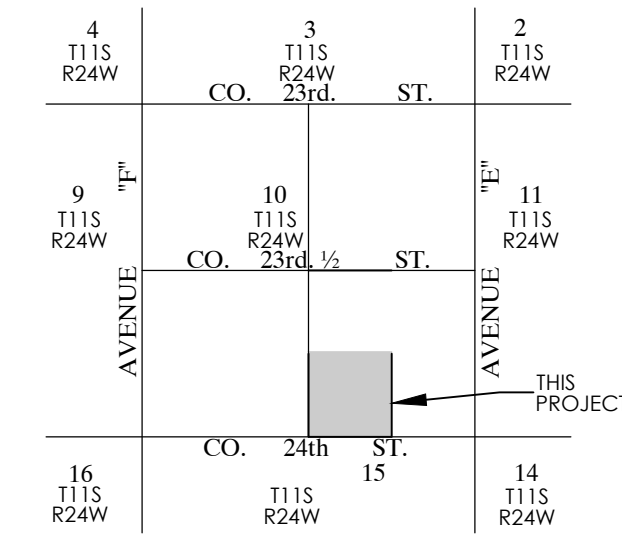

TRACT AREAS OWNER

TRACT	AREA	OWNER
"A"	1.47 ACRES	R&G ASSOCIATES LLC.

BASIS OF BEARING

THE WEST LINE OF THE SW 1/4 OF SECTION 10, T11S, R24W, G.S.R.B.&M., YUMA COUNTY, ARIZONA (BEING THE CENTERLINE OF AVENUE "F"), AS SHOWN ON BORDER RANCHES SUBDIVISION, AS RECORDED IN BOOK 27 OF PLATS, PAGES 9&10, YUMA COUNTY RECORDERS OFFICE, YUMA COUNTY, ARIZONA, NAMELY BEARING N00°02'42"W

SURVEYOR'S CERTIFICATE

I HEREBY CERTIFY THAT I AM A LAND SURVEYOR LISTED ON THE ROSTER OF ACTIVE REGISTRANTS BY THE STATE BOARD OF TECHNICAL REGISTRATION OF ARIZONA AND THAT THIS MAP CONSISTING OF ONE (1) SHEET CORRECTLY REPRESENTS A SURVEY MADE UNDER MY SUPERVISION THAT ALL MONUMENTS SHOWN HEREON ACTUALLY EXIST AND THEIR POSITIONS ARE CORRECTLY SHOWN.

PREPARED BY:
Edais Engineering, Inc.
3075 S. AVENUE 4 E
YUMA, ARIZONA 85365
(928) 344-3566

**PRELIMINARY
NOT FOR
CONSTRUCTION**

SANTA CECILIA No. 4 SUBDIVISION

LOT 3 OF BORDER RANCHES SUBDIVISION AS RECORDED IN BOOK 27 OF PLATS, PAGES 9-10,
YUMA COUNTY RECORDERS OFFICE, YUMA COUNTY, ARIZONA

DATE OF PREPARATION: AUGUST 2018 NUMBER OF LOTS: 134 ACREAGE: 36.76 ACRES

A.P.N. 227-10-001
STATE OF ARIZONA
(UNDEVELOPED LAND)
ZONING: R1-40

LINE DATA

LINE	LENGTH	BEARING	LINE	LENGTH	BEARING
L1	21.20'	N44°58'01"E	L8	42.44'	N45°01'59"W
L2	21.22'	N45°01'59"W	L9	42.41'	N44°58'01"W
L3	21.22'	S45°01'59"E	L10	42.41'	S44°57'45"W
L4	21.20'	S44°57'45"W	L11	42.45'	S45°02'15"E
L5	21.22'	S45°02'15"E			
L6	50.00'	S10°19'26"W			
L7	49.84'	N79°34'51"E			

CURVE DATA

CURVE	DELTA	CHORD DIRECTION	CHORD	TANGENT	RADIUS	LENGTH
C4	110°44'35"	N45°02'51"W	98.74'	86.88'	60.00'	115.97'

AREAS

LOT	AREA	LOT	AREA	LOT	AREA	LOT	AREA	LOT	AREA	LOT	AREA	LOT	AREA
473	6137.50 SF	493	6000.00 SF	513	5997.17 SF	533	6314.00 SF	553	5999.99 SF	573	6340.21 SF	593	6205.42 SF
474	6670.00 SF	494	6387.50 SF	514	6734.65 SF	534	6314.00 SF	554	6000.01 SF	574	6340.21 SF	594	6362.89 SF
475	6670.00 SF	495	6887.51 SF	515	6437.50 SF	535	6314.00 SF	555	5999.98 SF	575	6414.48 SF	595	6387.50 SF
476	6670.00 SF	496	6566.01 SF	516	6583.00 SF	536	6314.00 SF	556	6000.00 SF	576	6414.48 SF	596	6229.00 SF
477	6670.00 SF	497	6566.02 SF	517	6583.00 SF	537	6302.85 SF	557	6000.02 SF	577	6340.21 SF	597	6229.56 SF
478	6670.00 SF	498	6566.03 SF	518	6583.00 SF	538	6275.00 SF	558	6000.00 SF	578	6340.21 SF	598	6387.50 SF
479	6670.00 SF	499	6566.03 SF	519	6583.00 SF	539	6000.00 SF	559	6000.00 SF	579	6340.21 SF	599	6387.50 SF
480	6663.00 SF	500	6566.04 SF	520	6583.00 SF	540	6000.00 SF	560	6000.00 SF	580	6340.21 SF	600	6227.11 SF
481	6137.50 SF	501	6566.05 SF	521	6583.00 SF	541	6000.00 SF	561	6322.43 SF	581	6340.21 SF	601	6229.00 SF
482	5937.50 SF	502	6566.18 SF	522	6585.00 SF	542	6000.01 SF	562	6414.48 SF	582	6340.21 SF	602	6387.50 SF
483	6293.00 SF	503	6888.20 SF	523	6437.50 SF	543	6000.00 SF	563	6340.21 SF	583	6340.21 SF	603	6387.50 SF
484	6293.00 SF	504	8176.83 SF	524	6275.00 SF	544	6000.00 SF	564	6340.21 SF	584	6340.21 SF	604	6229.00 SF
485	6293.00 SF	505	5997.20 SF	525	6314.00 SF	545	6000.00 SF	565	6340.21 SF	585	6340.21 SF	605	6225.47 SF
486	6293.00 SF	506	5997.19 SF	526	6314.00 SF	546	6000.00 SF	566	6340.21 SF	586	6340.21 SF	606	6387.50 SF
487	6294.55 SF	507	5997.19 SF	527	6314.00 SF	547	6000.00 SF	567	6340.21 SF	587	6340.21 SF		
488	6673.86 SF	508	5997.19 SF	528	6314.00 SF	548	6000.00 SF	568	6340.21 SF	588	6340.21 SF		
489	9831.07 SF	509	5997.18 SF	529	6314.00 SF	549	6387.50 SF	569	6340.21 SF	589	6320.78 SF		
490	9831.82 SF	510	5997.18 SF	530	6314.00 SF	550	6387.50 SF	570	6340.21 SF	590	6414.48 SF		
491	6631.43 SF	511	5997.18 SF	531	6314.00 SF	551	6000.00 SF	571	6340.21 SF	591	6362.91 SF		
492	6000.00 SF	512	5997.18 SF	532	6314.00 SF	552	6000.00 SF	572	6340.21 SF	592	6207.61 SF		

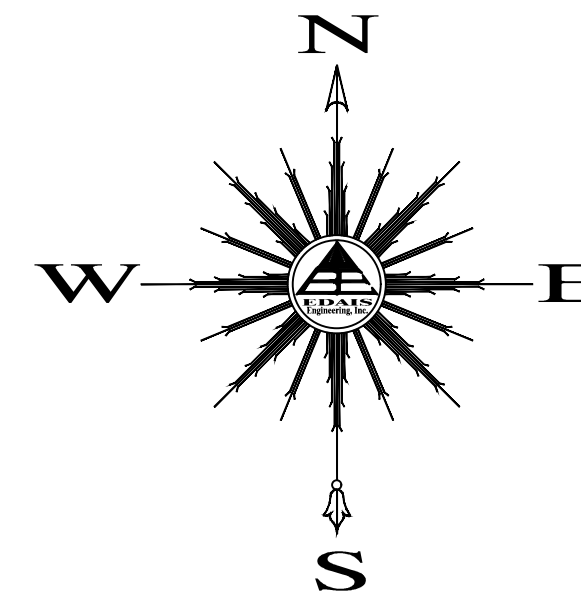

SCALE: 1" = 100'

LEGEND

- CENTERLINE
- RIGHT-OF-WAY (ROW) LINE
- NEW PROPERTY LINE
- EASEMENT (TYPE AS NOTED)
- BOUNDARY LINE
- NEW STREET MONUMENT AS PER YUMA COUNTY STD. DETAIL No. 4-080
- NEW SUBDIVISION BOUNDARY MONUMENT AS PER YUMA COUNTY STD. DETAIL No. 04-030
- EXISTING MONUMENT (TYPE AS SHOWN)
- ① NEW LOT NUMBER
- ④ EXISTING LOT NUMBER
- A.P.N. ASSESSOR PARCEL NUMBER
- B.C. BRASS CAP
- H.H. HAND HOLE
- (M) MEASURED DATA
- (R1) REFERS TO BORDER RANCHES SUBDIVISION RECORDED IN BOOK 27 OF PLATS, PAGE 9 YUMA COUNTY RECORDS
- (I1) DATA REFER TO GENERAL LAND OFFICE FLAT OF SECTION 10, T11S, R24, OFFICIALLY FILED ON 3-12-1922, YUMA COUNTY RECORDS, YUMA COUNTY, AZ. YUMA COUNTY RECORDS
- Y.C.R. YUMA COUNTY RECORDS
- G.&S.R.B.&M. GILA AND SALT RIVER BASE AND MERIDIAN

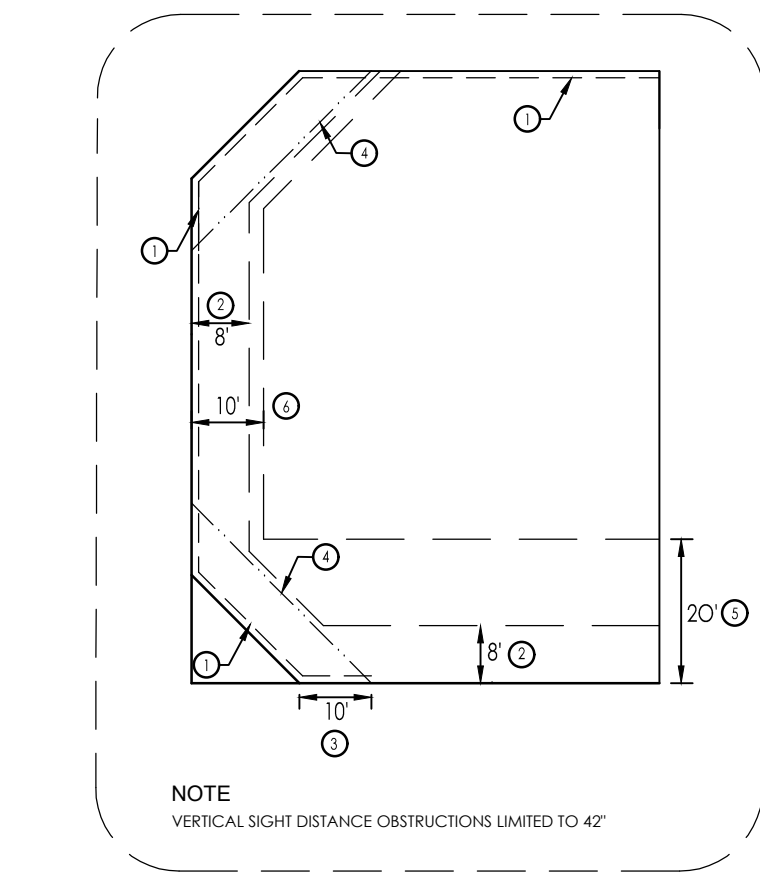
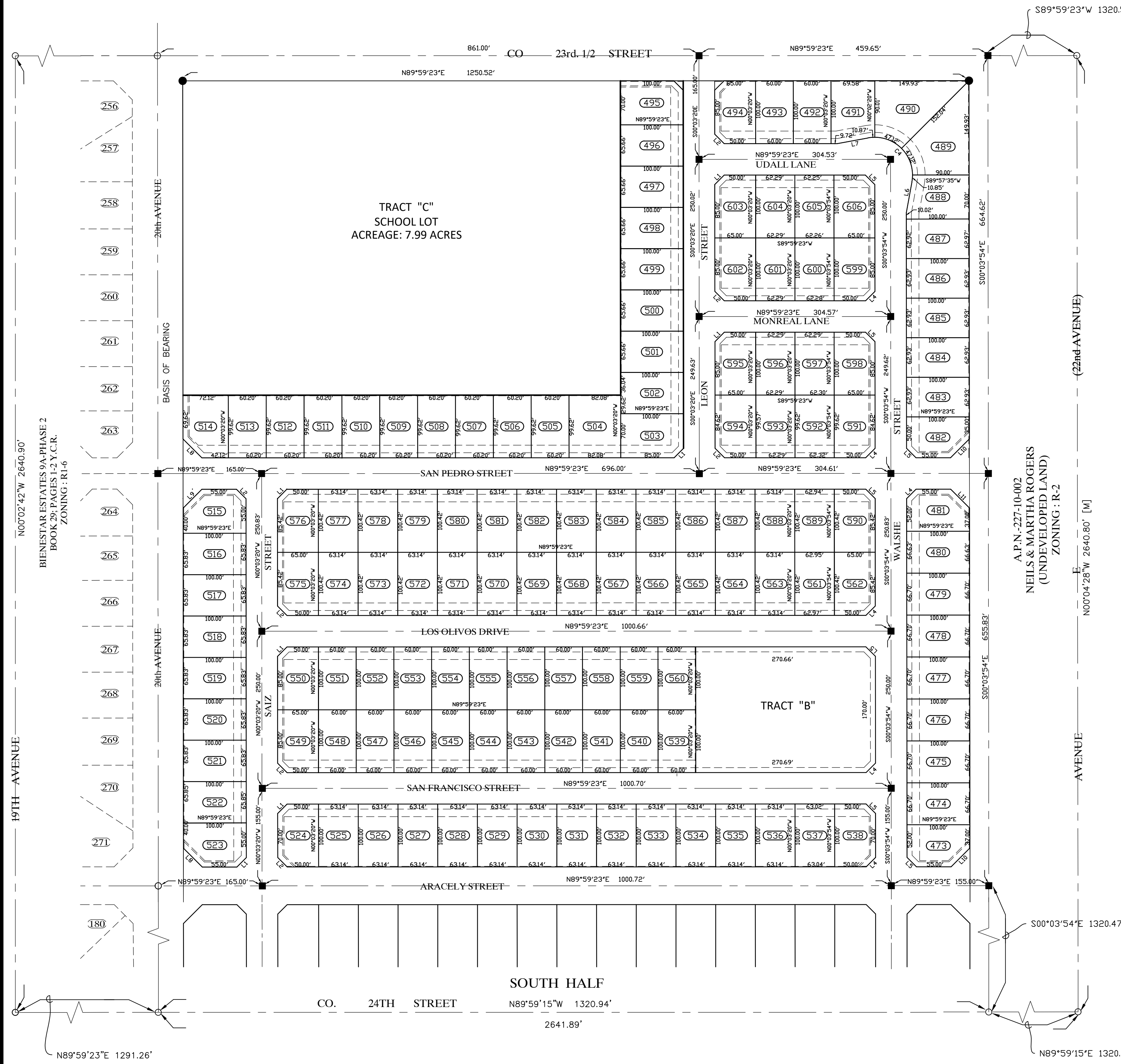

LOCATION MAP

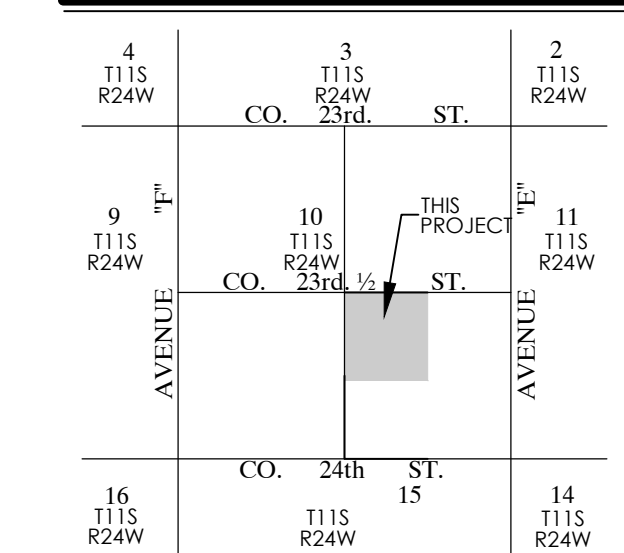

TRACT AREAS OWNER

TRACT	AREA	OWNER
"A"	1.91 ACRES	RIEDEL HOLDINGS, LLC
"B"	7.99 ACRES	P.O. BOX 1649 SAN LUIS, AZ 85349 (928) 627-8593

BASIS OF BEARING

THE WEST LINE OF THE SW 1/4 OF SECTION 10, T11S, R24W, G.&S.R.B.&M., YUMA COUNTY, ARIZONA (BEING THE CENTERLINE OF AVENUE "T"), AS SHOWN ON BORDER RANCHES SUBDIVISION, AS RECORDED IN BOOK 27 OF PLATS, PAGES 9&10, YUMA COUNTY RECORDERS OFFICE, YUMA COUNTY, ARIZONA, NAMELY BEARING N00°02'42"W

SURVEYOR'S CERTIFICATE

I HEREBY CERTIFY THAT I AM A LAND SURVEYOR LISTED ON THE ROSTER OF ACTIVE REGISTRANTS BY THE STATE BOARD OF TECHNICAL REGISTRATION OF ARIZONA AND THAT THIS MAP CONSISTING OF ONE (1) SHEET CORRECTLY REPRESENTS A SURVEY MADE UNDER MY SUPERVISION, THAT ALL MONUMENTS SHOWN HEREON ACTUALLY EXIST AND THEIR POSITIONS ARE CORRECTLY SHOWN.

PREPARED BY:

Edais
Engineering, Inc.
3075 S. AVENUE 4 E
YUMA, ARIZONA 85365
(928) 344-3566

**PRELIMINARY
NOT FOR
CONSTRUCTION**

WHEN RECORDED MAIL TO:
CITY OF SAN LUIS
P.O. BOX 1170
SAN LUIS, AZ 85349
ATTN: CITY CLERK

OFFICIAL RECORDS OF
YUMA COUNTY RECORDER
SUSAN MARLER



FEE #: 2007 – 16715

05/07/2007 10:08 PAGES: 0004
FEES: 3.00 4.00 1.00 .00 .00
REQ BY: CITY OF SAN LUIS
REC BY: PATTY MAGANA

COPY
AS TO FILING DATA ONLY

The above area is to be reserved for recording information

C A P T I O N H E A D I N G :

Ordinance No. 250



Ordinance

ORDINANCE NO. 250

OFFICE OF THE
MAYOR
CITY OF SAN LUIS

AN ORDINANCE OF THE MAYOR AND CITY COUNCIL OF THE CITY OF SAN LUIS, ARIZONA, AMENDING ORDINANCE NO. 13, AS AMENDED, REZONING 280 ACRES LOCATED AT THE NORTH-EAST CORNER OF AVENUE 'F' AND COUNTY 24TH STREET FROM COUNTY RURAL AREA TEN (10) ACRE PARCELS (RA-10) TO INTERMEDIATE DENSITY RESIDENTIAL (R-2) ON 257.5 ACRES, TO HIGH DENSITY RESIDENTIAL (R-3) ON 10 ACRES AND TO GENERAL COMMERCIAL (C-2) ON 12.5 ACRES, AND AMENDING THE ZONING MAP TO CONFORM THERETO.

BE IT ORDAINED BY THE MAYOR AND COUNCIL OF THE CITY OF SAN LUIS, ARIZONA, AS FOLLOWS:

Section 1: That Ordinance #13, as amended, be further amended that the real property described as follows:

The southwest quarter of section 10 except the south 330 feet of the west 330 feet.

The southeast quarter of section 10 except the southeast quarter of the southeast quarter and except the east half of the north-east quarter of the southeast quarter of said section 10.

Said section 10 being in Township 11 South, Range 24 West of the Gila and Salt River Base and Meridian. Yuma County, Arizona.

Be rezoned from County RA-10 to Intermediate Density Residential (R-2) as defined in Ordinance #13, as amended, and upon this ordinance taking effect, shall be subject to all rules, regulations and requirements of the R-2 Zoning District of Ordinance #13, as amended.

Section 2: That Ordinance #13, as amended, be further amended that the real property described as follows:

The west half of the east half of the northeast quarter of the southeast quarter of Section 10, Township 11 South, Range 24 West of the Gila and Salt River Base and Meridian. Yuma County, Arizona.

Be rezoned from County RA-10 to High Density Residential (R-3) as defined in Ordinance #13, as amended, and upon this ordinance taking effect, shall be subject to all rules, regulations and requirements of the R-3 Zoning District of Ordinance #13, as amended.

Section 3: That Ordinance #13, as amended, be further amended that the real property described as follows:

The south 330 feet of the west 330 feet of the southwest quarter and the east half of the east half of the northeast quarter of the southeast quarter of Section 10, Township 11 South, Range 24 West of the Gila and Salt River Base and Meridian. Yuma County, Arizona.

Be rezoned from County RA-10 to General Commercial (C-2) as defined in Ordinance #13, as amended, and upon this ordinance taking effect, shall be subject to all rules, regulations, and requirements of the C-2 Zoning District of Ordinance #13, as amended.

Section 4: Adoption of this ordinance will include the following conditions:

1. Dedication of an additional seventeen feet of street right-of-way along County 24th Street.
2. Dedication of an additional seventeen feet of street right-of-way along Avenue 'F'
3. Dedication of forty (40) feet of street right-of-way along County 23 ½ Street.
4. All off-site improvements noted in the "Joint Development Agreement" made on the 16th day of March 2007 between the Comite de Bienestar, Border Ranches LLC and Sam Group to be constructed.
5. That land be dedicated and developed throughout the property being rezoned for parks and recreation purposes, at no cost to the City. These dedications shall be made at the discretion of the city and approved at the time of subdivision plat approval. The amount acreage dedicated shall not be less than a total of 12 nor more than 15 acres. Said land may be used for water/drainage retention purposes.
6. That the property be developed and all of the conditions met within 5 years of the effective date of this ordinance or the zoning will revert to the present previous zoning classification.

Section 5: That the zoning map adopted under said Ordinance #13, as amended is hereby ordered to be changed so as to show that said real property described in this ordinance is located within the zoning district herein provided.

PASSED AND ADOPTED by the Mayor and City Council of the City of San Luis,
Arizona, this 25th day of April, 2007.



Juan Carlos Escamilla, Mayor

ATTEST:

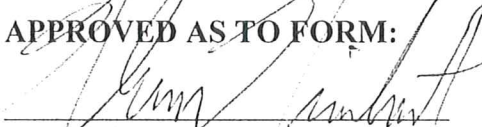

Sonia Sanchez, City Clerk

APPROVED AS TO FORM:



Glenn Gimbut, City Attorney

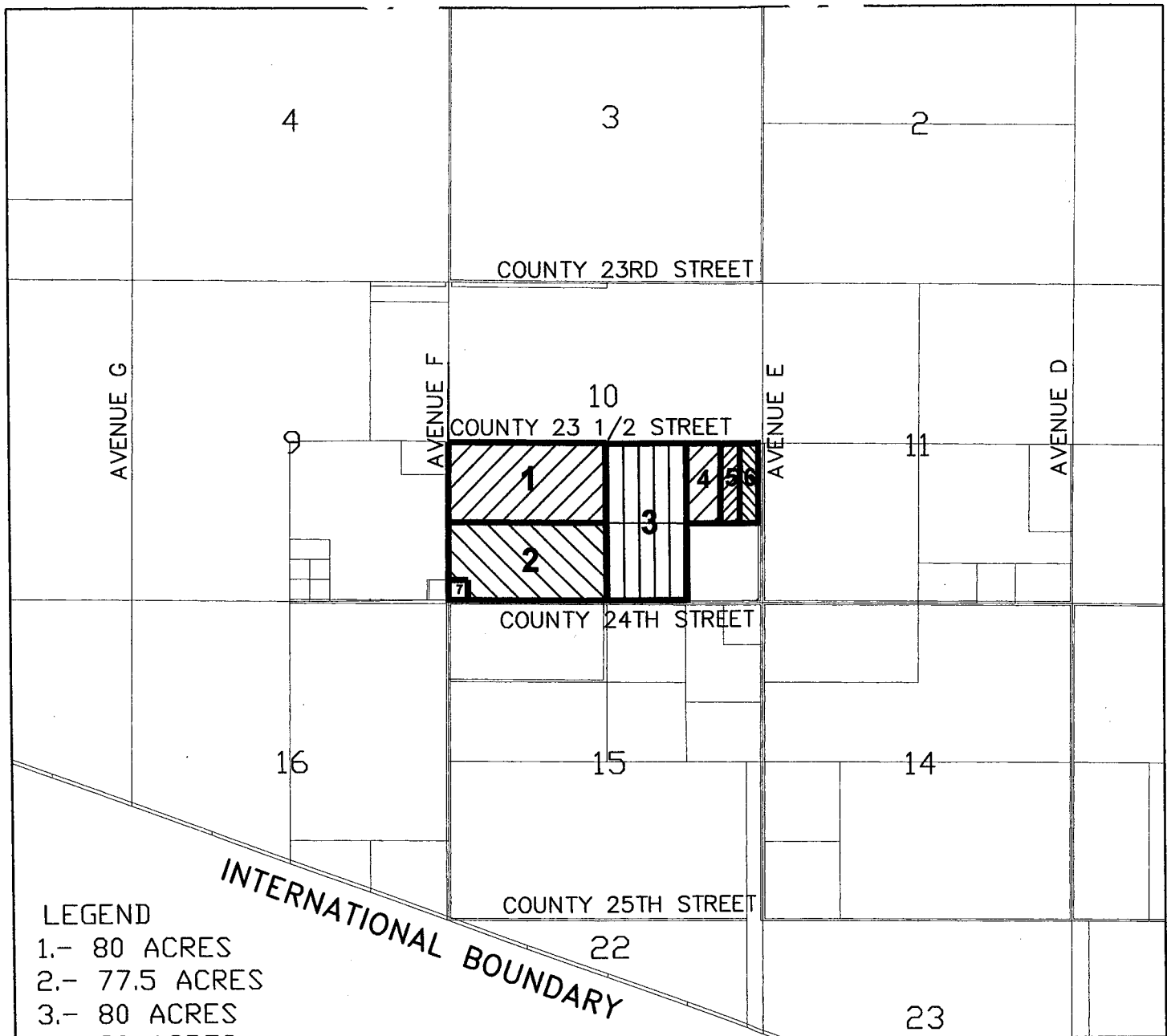

LEGEND

- 1.- 80 ACRES
- 2.- 77.5 ACRES
- 3.- 80 ACRES
- 4.- 20 ACRES
- 5.- 10 ACRES
- 6.- 10 ACRES
- 7.- 2.5 ACRES

LOCATION MAP

LOCATION OF SUBJECT PROPERTY



Rezoning 07-04

ORDINANCE NO.

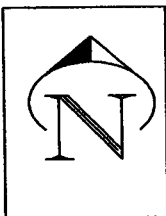

Prepared By: DMS

Checked By:

Planning & Zoning
GIS Work



Date: 12/10/07

Revised:

250



September 14, 2018

REZONING CASE NUMBER: 2018-0458

CASE SUMMARY: A request by Riedel Holdings LLC, applicant, on behalf of Border Ranches, LLC, owner, to rezone 67.06 acres from Medium-High Density Residential (R-2) to Medium Density Residential (R1-6) zoning district. Assessor parcel ID # 227-10-009 located at North-west corner of County 24th and 20th Avenue, San Luis, Arizona. The purpose of the zone change is to allow for the building of a future subdivisions to be called Santa Cecilia No. 3 and 4.

A Citizen Review Meeting has been scheduled on the 2nd day of October, 2018 at 6:00 p.m. at the San Luis City Hall Council Chambers, 1090 E. Union Street, San Luis, Arizona, in order to give interested parties an opportunity to meet with the applicant to have questions answered and express any issues or concerns prior to any public hearing.

PUBLIC HEARING: October 9, 2018

COMMENTS DUE: September 20, 2018

Your comments on this case will help us prepare an accurate and timely staff report. Your comments on this case will be inserted "as is" into the staff report with your name, department, and telephone number, should the applicant have any questions. Your comments are a public record and will be available to the public, media, and the applicant, in addition to the Commission hearing this case. Please complete the section below and return via e-mail. For additional information please contact me at 341-8563, extension 2014, or at Jaguzman@cityofsanluis.org

Thank you,

Jose A. Guzman
Director of Planning & Zoning
Attachment: Location Map and Conceptual Plan

.....
 COMMENTS NO COMMENTS

Enter Comments below:

The City of San Luis Fire Department has no comments at this time, but reserves the right to comment upon subsequent submittals. Final decisions regarding this request are best made by the Planning and Zoning Department

Date:

09/17/18

Agency:

The City of San Luis Fire Department

Phone:

928/341-8550

Return to: P&Z@cityofsanluis.org



September 14, 2018

REZONING CASE NUMBER: 2018-0458

CASE SUMMARY: A request by Riedel Holdings LLC, applicant, on behalf of Border Ranches, LLC, owner, to rezone 67.06 acres from Medium-High Density Residential (R-2) to Medium Density Residential (R1-6) zoning district. Assessor parcel ID # 227-10-009 located at North-west corner of County 24th and 20th Avenue, San Luis, Arizona. The purpose of the zone change is to allow for the building of a future subdivisions to be called Santa Cecilia No. 3 and 4.

A Citizen Review Meeting has been scheduled on the 2nd day of October, 2018 at 6:00 p.m. at the San Luis City Hall Council Chambers, 1090 E. Union Street, San Luis, Arizona, in order to give interested parties an opportunity to meet with the applicant to have questions answered and express any issues or concerns prior to any public hearing.

PUBLIC HEARING: October 9, 2018

COMMENTS DUE: September 20, 2018

Your comments on this case will help us prepare an accurate and timely staff report. Your comments on this case will be inserted “as is” into the staff report with your name, department, and telephone number, should the applicant have any questions. Your comments are a public record and will be available to the public, media, and the applicant, in addition to the Commission hearing this case. Please complete the section below and return via e-mail. For additional information please contact me at 341-8563, extension 2014, or at Jaguzman@cityofsanluis.org

Thank you,

Jose A. Guzman
Director of Planning & Zoning
Attachment: Location Map and Conceptual Plan

.....
 COMMENTS NO COMMENTS

Enter Comments below:

The property is located near Rolle Airfield where aviation activity is expected to increase in the near future. It is recommended to submit an Avigation Easement acknowledging aviation activities. Thank you for the opportunity to comment.

Date:

9/15/18

Agency:

Yuma County Airport Authority

Phone:

928-726-5882

Return to: P&Z@cityofsanluis.org