

SANTA CECILIA No. 4 SUBDIVISION

A SUBDIVISION OF LOT 3A OF SANTA CECILIA LOT TIE/LOT SPLIT AS RECORDED IN BOOK 30 OF PLATS,
 PAGE 98, YUMA COUNTY RECORDERS OFFICE, YUMA COUNTY, ARIZONA
 AND A PORTION OF THE NW1/4 SE1/4 OF SECTION 10, T11S, R24W, G.&S.R.B.&M., YUMA COUNTY, ARIZONA.
 DATE OF PREPARATION: AUGUST 2018 NUMBER OF LOTS: 173 ACREAGE: 36.79 ACRES



BOOK _____ OF PLATS,
 PAGE _____

FINAL PLAT

APPROVED

STATE OF ARIZONA)
) ss
 CITY OF SAN LUIS)

THIS SUBDIVISION AS PLATTED HEREON HAS BEEN APPROVED BY THE
 MAYOR AND THE CITY COUNCIL OF THE CITY OF SAN LUIS, ARIZONA.

MAYOR _____ DATE _____

CITY MANAGER _____ DATE _____

DIRECTOR OF PLANNING AND ZONING DEPARTMENT _____ DATE _____

CITY ENGINEER _____ DATE _____

CITY PUBLIC WORKS DIRECTOR _____ DATE _____

BASIS OF BEARING

THE WEST LINE OF THE SW 1/4 OF SECTION 10, T11S, R24W,
 G.&S.R.B.&M., YUMA COUNTY, ARIZONA (BEING THE CENTERLINE OF
 AVENUE "F"), AS SHOWN ON BORDER RANGES SUBDIVISION, AS
 RECORDED IN BOOK 27 OF PLATS, PAGES 9&10, YUMA COUNTY
 RECORDERS OFFICE, YUMA COUNTY, ARIZONA,
 BEARING N00°02'42"W

RESTRICTIVE COVENANTS

HAVE BEEN RECORDED CONCURRENTLY AND ARE A PART OF THIS PLAT

SUBDIVIDER/OWNER

RIEDEL HOLDINGS, LLC
 1910 JUAN SANCHEZ BLVD
 P.O. BOX 1649
 SAN LUIS, AZ 85349
 (928) 627-8593

PREPARED BY:

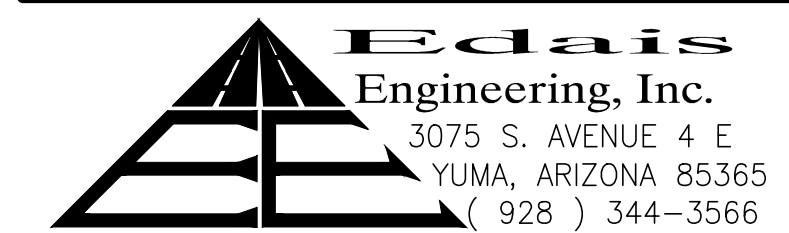

SURVEYOR'S CERTIFICATE

I HEREBY CERTIFY THAT I AM A LAND SURVEYOR LISTED ON THE ROSTER OF ACTIVE
 REGISTRANTS BY THE STATE BOARD OF TECHNICAL REGISTRATION OF ARIZONA AND
 THAT THIS MAP CONSISTING OF TWO(2) SHEET CORRECTLY REPRESENTS A SURVEY
 MADE UNDER MY SUPERVISION. THAT ALL MONUMENTS SHOWN HEREON ACTUALLY
 EXIST AND THEIR POSITIONS ARE CORRECTLY SHOWN.

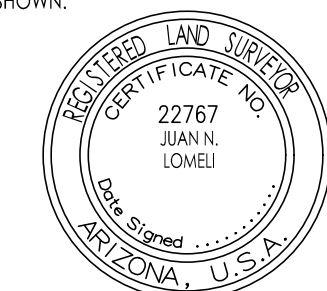

JUAN N. LOMEI R.L.S. No. 22767

DEDICATION

KNOW ALL MEN BY THESE PRESENTS: THAT RIEDEL HOLDINGS, L.L.C., AN ARIZONA LIMITED LIABILITY COMPANY, AS OWNER HAS THIS THE ____ DAY OF _____ 2019,
 CAUSED A PORTION OF THE SW 1/4 OF SECTION 10, T11S, R24W, G. & S. R. B. & M. YUMA COUNTY, ARIZONA, AS PLATTED HEREON,
 TO BE SUBDIVIDED INTO LOTS, TRACT & STREETS UNDER THE NAME OF "SANTA CECILIA No. 3 SUBDIVISION" AND HEREBY DECLARES THAT THE ACCOMPANYING PLAT
 SETS FORTH THE LOCATION AND GIVES THE DIMENSIONS OF THE LOTS AND STREETS, CONSTITUTING SAID "SANTA CECILIA No. 3 SUBDIVISION" AND THAT EACH LOT
 SHALL BE KNOWN BY THE NUMBER, THE TRACT BY THE LETTER AND THE STREETS BY THE NAME GIVEN EACH RESPECTIVELY ON SAID PLAT;

AND THAT RIEDEL HOLDINGS, L.L.C., AS OWNER, HEREBY DEDICATES THE STREETS SHOWN HEREON TO THE PUBLIC FOR ITS USE AND BENEFIT, AND THAT THE
 EASEMENTS ARE DEDICATED FOR THE USES SHOWN AND DEFINED ON SAID PLAT AND AS SET FORTH IN THE DECLARATION OF RESERVATIONS, COVENANTS,
 CONDITIONS AND RESTRICTIONS RECORDED CONCURRENTLY HEREWITH. TRACT "A" IS DEDICATED TO THE PUBLIC FOR USE AS STORM WATER RETENTION BASIN AND
 COMPATIBLE RECREATIONAL USES. THE EASEMENTS ARE DEDICATED FOR THE PURPOSE SHOWN HEREON. A THREE FOOT NON-CONSTRUCTION AND NO OBSTRUCTION
 EASEMENT FROM THE FURTHER PROJECTION ON ANY SIDE OF ALL FIRE HYDRANTS; A TWELVE INCH NON-CONSTRUCTION AND NO OBSTRUCTION EASEMENT AROUND
 WATER METERS; AND 24 INCH NON-CONSTRUCTION AND NO OBSTRUCTION EASEMENT FOR STREET LIGHTS IS HEREBY GRANTED.

IN WITNESS WHEREOF: RIEDEL HOLDINGS, L.L.C., HAS CAUSED ITS CORPORATE NAME TO BE SIGNED AND ITS CORPORATE SEAL TO BE AFFIXED BY THE SIGNATURE
 OF NIEVES GARCIA RIEDEL, AS MEMBER, THEREUNTO DULY AUTHORIZED ON THIS THE ____ DAY OF _____ 2019.

BY: _____
 NIEVES GARCIA RIEDEL, MEMBER
 RIEDEL HOLDINGS, L.L.C.

ACKNOWLEDGMENT

STATE OF ARIZONA)
) ss
 COUNTY OF YUMA)

ON THIS THE ____ DAY OF _____, 2019 BEFORE ME, THE UNDERSIGNED OFFICER
 PERSONALLY APPEARED, NIEVES GARCIA RIEDEL, WHO ACKNOWLEDGED HERSELF TO BE MEMBER OF
 RIEDEL HOLDINGS, L.L.C., AN ARIZONA LIMITED LIABILITY COMPANY, AND SHE AS SUCH OFFICER BEING
 AUTHORIZED TO DO SO, EXECUTED THE FOREGOING INSTRUMENT FOR THE PURPOSES THEREIN
 CONTAINED, BY SIGNING THE NAME OF THE LIMITED LIABILITY COMPANY BY HERSELF, AS SUCH
 OFFICER.

IN WITNESS WHEREOF, I HAVE SET MY HAND AND OFFICIAL SEAL.

BY: _____
 NOTARY PUBLIC

MY COMMISSION EXPIRES: _____



SANTA CECILIA No. 4

VICINITY MAP

N.T.S
 City of San Luis AZ.

SANTA CECILIA No. 4 SUBDIVISION

A SUBDIVISION OF LOT 3A OF SANTA CECILIA LOT TIE/LOT SPLIT AS RECORDED IN BOOK 30 OF PLATS,
PAGE 98, YUMA COUNTY RECORDERS OFFICE, YUMA COUNTY, ARIZONA
AND A PORTION OF THE NW1/4 SE1/4 OF SECTION 10, T11S, R24W, G.&S.R.B.&M., YUMA COUNTY, ARIZONA.

DATE OF PREPARATION: AUGUST 2018 NUMBER OF LOTS: 173 ACREAGE: 36.79 ACRES

FINAL PLAT

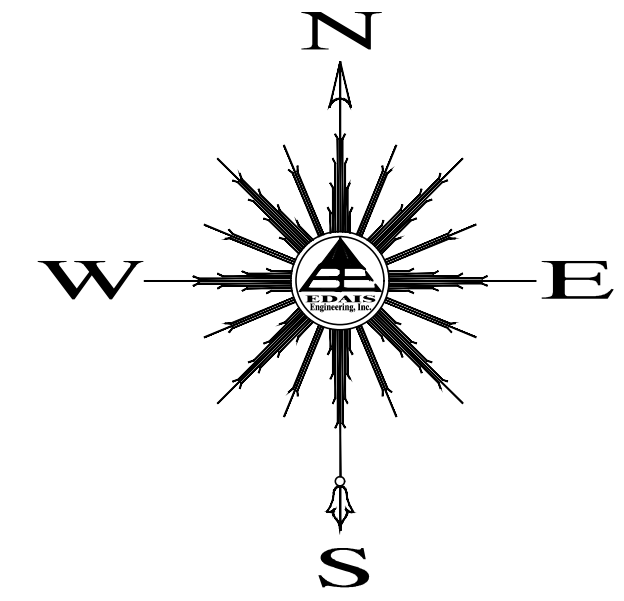

SCALE: 1" = 100'

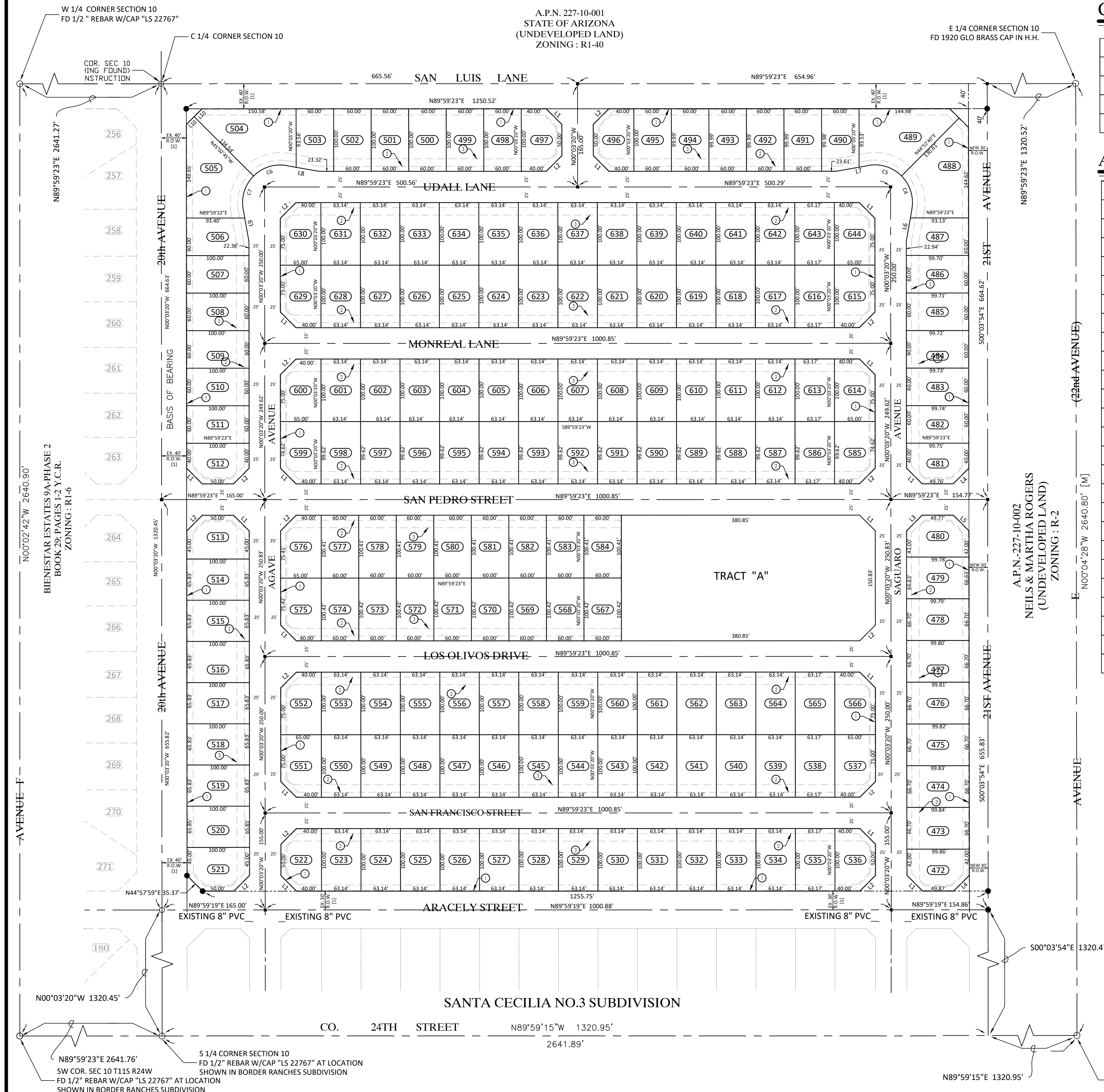

CURVE DATA

CURVE	DELTA	CHORD DIRECTION	CHORD	TANGENT	RADIUS	LENGTH
C4	034°37'24"	N07°19'19"W	35.71'	18.70'	60.00'	36.26'
C5	034°37'28"	N82°44'36"W	35.71'	18.70'	60.00'	36.26'
C6	034°37'58"	S82°39'03"W	35.71'	18.70'	59.98'	36.26'
C7	034°37'58"	S07°17'00"W	151.43'	18.70'	59.98'	36.26'

LINE DATA

LINE	LENGTH	BEARING	LINE	LENGTH	BEARING
L1	35.37	N45°01'59"W	L6	52.06	S09°59'23"W
L2	35.34	N44°58'01"E	L7	52.06	S79°56'40"W
L3	35.37	N45°02'15"W	L8	52.62	S80°03'20"E
L4	35.34	N44°57'45"E	L9	52.62	S10°00'37"E
L5	35.37	S45°02'15"W	L10	17.68	S44°59'51"W

AREAS

LOT	AREA	LOT	AREA	LOT	AREA	LOT	AREA	LOT	AREA	LOT	AREA		
472	6065.70 SF	497	5875.00 SF	522	5875.00 SF	547	6314.00 SF	572	6025.20 SF	597	6290.07 SF	622	6314.00 SF
473	6660.01 SF	498	6000.00 SF	523	6314.00 SF	548	6314.00 SF	573	6025.20 SF	598	6290.06 SF	623	6314.00 SF
474	6659.29 SF	499	6000.00 SF	524	6314.00 SF	549	6314.00 SF	574	6025.20 SF	599	6162.86 SF	624	6314.00 SF
475	6658.56 SF	500	6000.00 SF	525	6314.00 SF	550	6314.00 SF	575	6214.80 SF	600	6187.50 SF	625	6314.00 SF
476	6657.83 SF	501	6000.00 SF	526	6314.00 SF	551	6187.50 SF	576	6214.15 SF	601	6314.00 SF	626	6314.00 SF
477	6657.10 SF	502	6000.00 SF	527	6314.00 SF	552	6187.50 SF	577	6024.60 SF	602	6314.00 SF	627	6314.00 SF
478	6656.37 SF	503	5881.88 SF	528	6314.00 SF	553	6314.00 SF	578	6024.60 SF	603	6314.00 SF	628	6314.00 SF
479	6648.66 SF	504	12014.87 SF	529	6314.00 SF	554	6314.00 SF	579	6024.60 SF	604	6314.00 SF	629	6187.50 SF
480	6059.78 SF	505	11932.67 SF	530	6314.00 SF	555	6314.00 SF	580	6024.60 SF	605	6314.00 SF	630	6187.50 SF
481	5859.07 SF	506	5875.81 SF	531	6314.00 SF	556	6314.00 SF	581	6024.60 SF	606	6314.00 SF	631	6314.00 SF
482	5984.68 SF	507	6000.00 SF	532	6314.00 SF	557	6314.00 SF	582	6024.60 SF	607	6314.00 SF	632	6314.00 SF
483	5984.09 SF	508	6000.00 SF	533	6314.00 SF	558	6314.00 SF	583	6024.60 SF	608	6314.00 SF	633	6314.00 SF
484	5983.50 SF	509	6000.00 SF	534	6314.00 SF	559	6314.00 SF	584	6024.60 SF	609	6314.00 SF	634	6314.00 SF
485	5982.91 SF	510	6000.00 SF	535	6317.00 SF	560	6314.00 SF	585	6162.90 SF	610	6314.00 SF	635	6314.00 SF
486	5982.32 SF	511	6000.00 SF	536	5875.00 SF	561	6314.00 SF	586	6293.09 SF	611	6314.00 SF	636	6314.00 SF
487	5860.07 SF	512	5875.00 SF	537	6186.50 SF	562	6314.00 SF	587	6290.10 SF	612	6314.00 SF	637	6314.00 SF
488	11822.79 SF	513	6375.00 SF	538	6315.43 SF	563	6314.00 SF	588	6290.10 SF	613	6317.00 SF	638	6314.00 SF
489	11901.28 SF	514	6583.00 SF	539	6312.43 SF	564	6314.00 SF	589	6290.09 SF	614	6187.51 SF	639	6314.00 SF
490	5881.56 SF	515	6583.00 SF	540	6312.43 SF	565	6317.00 SF	590	6290.09 SF	615	6187.50 SF	640	6314.00 SF
491	5999.03 SF	516	6583.00 SF	541	6314.00 SF	566	6187.50 SF	591	6290.09 SF	616	6317.00 SF	641	6314.00 SF
492	5999.22 SF	517	6583.00 SF	542	6314.00 SF	567	6025.20 SF	592	6290.08 SF	617	6314.00 SF	642	6314.00 SF
493	5999.40 SF	518	6583.00 SF	543	6314.00 SF	568	6025.20 SF	593	6290.08 SF	618	6314.00 SF	643	6317.00 SF
494	5999.59 SF	519	6583.00 SF	544	6314.00 SF	569	6025.20 SF	594	6290.08 SF	619	6314.00 SF	644	6187.50 SF
495	5999.78 SF	520	6585.00 SF	545	6314.00 SF	570	6025.20 SF	595	6290.07 SF	620	6314.00 SF		
496	5874.96 SF	521	6375.00 SF	546	6314.00 SF	571	6025.20 SF	596	6290.07 SF	621	6314.00 SF		

LEGEND

- CENTERLINE
- RIGHT-OF-WAY (ROW) LINE
- NEW PROPERTY LINE
- EASEMENT (TYPE AS NOTED)
- BOUNDARY LINE
- NEW STREET MONUMENT AS PER YUMA COUNTY STD. DETAIL No. 4-080
- NEW SUBDIVISION BOUNDARY MONUMENT AS PER YUMA COUNTY STD. DETAIL No. 04-030
- EXISTING MONUMENT (TYPE AS SHOWN)
- (170) NEW LOT NUMBER
- (47) EXISTING LOT NUMBER
- A.P.N. ASSESSOR PARCEL NUMBER
- B.C. BRASS CAP
- H.H. HAND HOLE
- Y.C.R. YUMA COUNTY RECORDS
- G.&S.R.B.&M. GILA AND SALT RIVER BASE AND MERIDIAN
- (1) EXISTING R.O.W. PER SANTA CECILIA LOT TIE/LOT SPLIT AS RECORDED IN BOOK 30, PAGE 98, Y.C.R.

LOCATION MAP

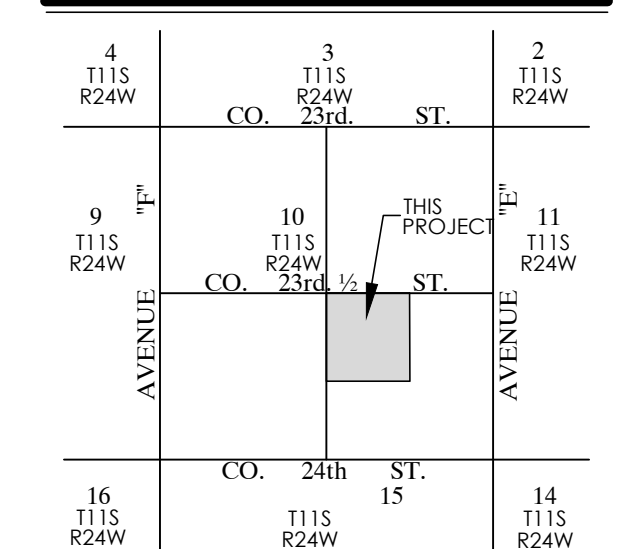

OWNER

RIEDEL HOLDINGS, LLC
P.O. BOX 1649
SAN LUIS, AZ 85349
(928) 627-8593

TRACT AREAS

TRACT	AREA
"A"	1.85 ACRES

SURVEYOR'S CERTIFICATE

I HEREBY CERTIFY THAT I AM A LAND SURVEYOR LISTED ON THE ROSTER OF ACTIVE REGISTRANTS BY THE STATE BOARD OF TECHNICAL REGISTRATION OF ARIZONA AND THAT THIS MAP CONSISTING OF TWO (2) SHEETS CORRECTLY REPRESENTS A SURVEY MADE UNDER MY SUPERVISION, THAT ALL MONUMENTS SHOWN HEREON ACTUALLY EXIST AND THEIR POSITIONS ARE CORRECTLY SHOWN.



JUAN N. LOMEI R.L.S. No. 22767

KEYNOTES

- 1 NEW 1' NON-ACCESS EASEMENT
- 2 NEW 8' UTILITY & CATV EASEMENT
- 3 INDICATES 1' NON-ACCESS EASEMENT
- 4 25' VISIBILITY TRIANGLE SEE TYPICAL CORNER LOT DETAIL.
- 5 NEW 20' FRONT YARD SETBACK LINE.
- 6 NEW 10' SIDE YARD SETBACK LINE.
- 7 40' R.O.W. DEDICATED TO CITY OF SAN LUIS ON BOOK 27 PG. 9-10 OF PLATS, BORDER RANCHES SUBDIVISION.
- 8 EXISTING 8' UTILITY & CATV EASEMENT TO BE ABANDONED HEREWITH
- 9 NEW 10' REAR SETBACK LINE.

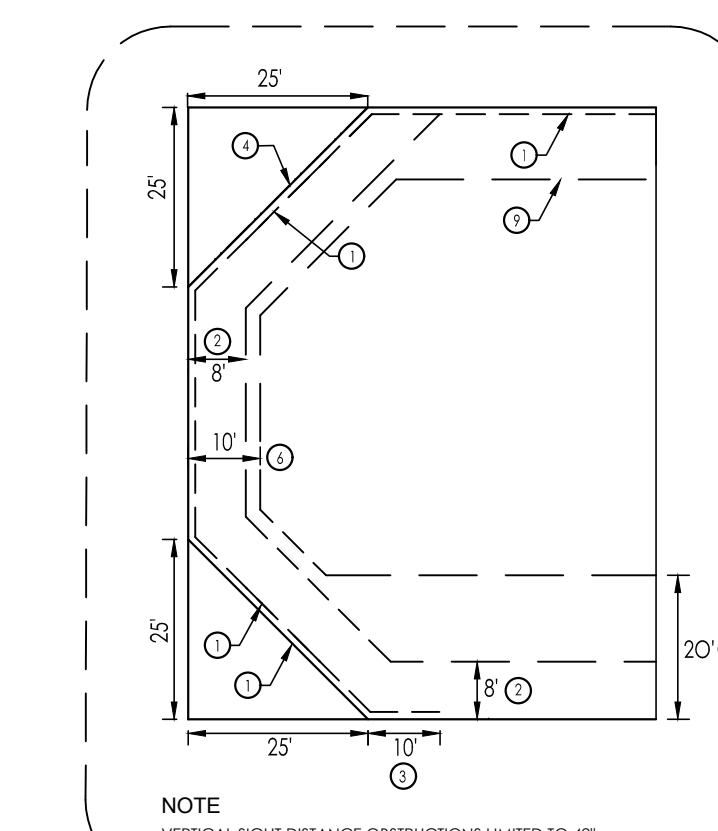

NOTE: VERTICAL SIGHT DISTANCE OBSTRUCTIONS LIMITED TO 42'
TYPICAL CORNER LOT DETAIL

PREPARED BY:

Edais Engineering, Inc.
3075 S. AVENUE 4 E
YUMA, ARIZONA 85365
(928) 344-3566