



NOTICE OF REGULAR COUNCIL MEETING

In accordance with §38-431.02 of the Arizona Revised Statutes of the State of Arizona, notice is hereby given to the Members of City Council and to the general public that the Mayor and Council of the City of San Luis, Arizona will hold a Regular City Council meeting at 7:00 p.m., Wednesday, January 8, 2020. The meeting will take place at the City Council Chambers, located at 1090 E. Union Street, San Luis, Arizona, 85349. Everyone from the public is invited to attend the open meeting.

In accordance with the Americans with Disabilities Act (ADA) and Section 504 of the Rehabilitation Act of 1973, the City of San Luis does not discriminate on the basis of disability in the admission of or access to, or treatment of employment in its programs, activities, or services. For information regarding rights and provisions of the ADA or Section 504, or to request reasonable accommodations for participation in City programs, activities or services contact: ADA/Section 504 Coordinator, City of San Luis Human Resources Department, 1090 E. Union Street, San Luis, Arizona, 85349; (928) 341-8520.

Notice is hereby given that pursuant to A.R.S. §1-602.A.9, subject to certain specified statutory exceptions, parents have a right to consent before the State or any of its political subdivisions make a video or audio recording of a minor child. Meetings of the City Council are audio and/or video recorded, and, as a result, proceedings in which children are present may be subject to such recordings. Parents in order to exercise their rights may either file written consent with the City Clerk to such recordings, or take personal action to ensure that their child or children are not present when a recording may be made. If a child is present at the time a recording is made, the city will assume that the rights afforded parents pursuant to A.R.S. §1-602.A.9 have been waived.

THIS NOTICE IS GIVEN BY:

/s/ Sonia Cornelio, City Clerk

AVISO DE JUNTA REGULAR

De acuerdo con los Estatutos del Estado de Arizona A.R.S. §38-431.02, se le informa a los miembros del Cabildo y al público en general que el Alcalde y el Cabildo, tendrán una Junta Regular a las 7:00 p.m., el día Miercoles, 8 de Enero del 2020. La junta se llevará a cabo en la Sala del Cabildo, ubicada en el 1090 E. Union Street, San Luis, Arizona, 85349. El público está cordialmente invitado a la junta.

De acuerdo con el Acta de Americanos con Discapacidades y la Sección 504 del Acta de Rehabilitación del 1973, la Ciudad de San Luis, Arizona no discrimina por causa de discapacidad la admisión y acceso a sus programas, actividades, servicios o en el trato en cuanto a empleo. Para más información referente a derechos y provisiones del Acta de Americanos con Discapacidades o Sección 504, o para solicitar adaptaciones que sean razonables para la participación en programas, actividades o servicios de la Ciudad, contactar al: Coordinador del Acta de Americanos con Discapacidades/Sección 504, Departamento de Recursos Humanos de la Ciudad de San Luis, Arizona, ubicado en el 1090 E. Union Street, San Luis, Arizona, 85349; (928) 341-8520.

Por medio de este aviso y de acuerdo con los Estatutos del Estado de Arizona A.R.S §1-602.A.9, sujeto a ciertas excepciones reglamentarias, los padres de familia tienen el derecho de dar el consentimiento ante el Estado o cualquiera de sus subdivisiones políticas para hacer una grabación de audio o video de su hijo menor de edad. Las juntas del Cabildo se graban en audio y/o video y como resultado, el hecho de que haya menores presentes puede ser sujeto a que sean grabados. Para que los padres de familia puedan ejercer sus derechos pueden dar el consentimiento por escrito con la Secretaria de la Ciudad a tal grabación, o tomar acción personal para asegurarse que su hijo menor no esté presente cuando la grabación se lleve a cabo. Si un menor de edad está presente en el momento de la grabación, la Ciudad asumirá que los padres de familia están cediendo los derechos sobre una posible grabación de acuerdo con los Estatutos del Estado de Arizona A.R.S. §1-602.A.9.

ESTE AVISO ES DADO POR:

/f/ Sonia Cornelio, Actuaría de la Ciudad



AGENDA
Regular Meeting
San Luis City Council
San Luis Council Chambers
1090 E. Union Street
San Luis, AZ 85349
January 8, 2020
7:00 p.m.

PLEASE TAKE NOTICE THAT MEMBERS OF THE CITY COUNCIL WILL ATTEND EITHER IN PERSON, TELEPHONE, OR VIDEO CONFERENCE COMMUNICATION. THE MAYOR OR ACTING MAYOR FOR THIS MEETING MAY CHANGE THE ORDER OF THE ITEMS; IF AUTHORIZED BY LAW AND BY A MAJORITY VOTE OF A QUORUM OF CITY COUNCIL MEMBERS PRESENT, AN EXECUTIVE SESSION WILL BE HELD IMMEDIATELY FOLLOWING THE VOTE IN ACCORDANCE WITH A.R.S. §38-431.03(A) AND THE MEETING WILL BE TEMPORARILY RECESSED WHILE THE CITY COUNCIL RETIRES TO EXECUTIVE SESSION WHICH WILL NOT BE OPEN TO THE PUBLIC.

- 1. CALL TO ORDER/ROLL CALL**
- 2. PLEDGE OF ALLEGIANCE**
- 3. INVOCATION**
- 4. PROCLAMATION**
- Lung Cancer Awareness Year 2020
- 5. CONSENT AGENDA**
All matters are considered to be routine by the City Council and will be enacted by one motion. If discussion is desired, that item will be removed from the Consent Agenda and will be considered separately.
- 5. A. MINUTES OF**
- Work Session held December 4, 2019
- Regular Council meeting held December 11, 2019
- Special Council meeting held December 23, 2019
- 5. B. DISBURSEMENTS FROM DECEMBER 14, 2019 THROUGH DECEMBER 27, 2019.**
Total Disbursements \$666,676.54
(Six Hundred Sixty-Six Thousand, Six Hundred Seventy-Six Dollars and Fifty-Four Cents)
- 6. DISCUSSION AND POSSIBLE ACTION ITEMS:**
- 6. A.** Presentation followed by discussion on any and all matters regarding the development of a bicycling program and its benefits. **(Gene Dalbey, President Yuma Region Bicycle Coalition)**

- 6. B.** Public hearing followed by discussion and possible action on any and all matters regarding the recommendation of a Special Event Liquor License Application to the Arizona Department of Liquor Licenses and Control to authorize the City of San Luis Parks & Recreation Department and Jaizu Entertainment Promotions to sell alcohol at the Lechuga Fest to be held on Saturday, January 25, 2020. **(Lizandro Galaviz, Director of Parks & Recreation Department)**
- A. Open public hearing
 - 1. Presentation by staff and/or applicant
 - 2. Call to the public on this item
 - B. Close public hearing
 - C. Action on Special Event Liquor License Application to the Arizona Department of Liquor Licenses & Control
- 6. C.** Discussion and possible action on any and all matters regarding authorization to purchase Mk 5 Model 895 Parking Meters with Apple Pay and Top Dome to replace out of service meters using Fiscal Year 2019-2020 Capital Projects budgeted funds. **(Richard Jessup, Chief of Police)**
- 6. D.** Discussion and possible action on any and all matters regarding Order No. 2020-1. An order of the Mayor and City Council of San Luis, Arizona to authorize the San Luis Police Department to receive additional funding for equipment by approving Highway Safety Contract Number 2020-PTS-054 amendment number 2020-012 between the City Of San Luis, Arizona through the San Luis Police Department and the Arizona Governor's Office of Highway Safety. **(Richard Jessup, Chief of Police)**
- 6. E.** Discussion and possible action on any and all matters regarding Subdivision Case No. 2019-0669F. A request by Riedel Holdings LLC, on behalf of Border Ranches LLC, property owner, for the final plat approval for Santa Cecilia No. 4 Subdivision. The property is located on the northeast corner of Aracely Street and 20th Avenue, Assessor's Parcel No. 227-10-013, San Luis, Arizona. **(Jose A. Guzman, Director of Planning and Zoning)**
- A. Staff presentation
 - B. Action on Subdivision Case No. 2019-0669F
- 6. F.** Discussion and possible action on any and all matters regarding Resolution No. 2112. A resolution of the Mayor and City Council of the City of San Luis, Arizona, creating a Street Lighting Improvement District and declaring its intention to purchase electricity, and maintain poles, luminaries, and underground conduit, together with a charge for the use of lighting facilities, for lighting public streets within the area described as Santa Cecilia No. 4 Subdivision, San Luis, Arizona. **(Jose A. Guzman, Director of Planning & Zoning)**
- 6. G.** Discussion and possible action on any and all matters regarding Resolution No. 2113. A resolution of the Mayor and City Council of the City of San Luis, Arizona, declaring its intention to provide the Enhanced Municipal Services of operating and maintaining certain retention basins within the area described as Santa Cecilia No. 4 Subdivision, San Luis, Arizona. **(Jose A. Guzman, Director of Planning & Zoning)**

- 6. H.** Discussion and possible action on any and all matters regarding Resolution No. 2114. A resolution of the Mayor and City Council of the City of San Luis, Arizona declaring its intention of operating, maintaining and repairing certain landscape improvements included within, near and adjacent to the retention and detention basins and parking and parkways and related facilities together with pertinent structures within the area described as Santa Cecilia No. 4 Subdivision, San Luis, Arizona. **(Jose A. Guzman, Director of Planning & Zoning)**
- 6. I.** Discussion and possible action on any and all matters regarding Resolution No. 2115. A resolution of the Mayor and City Council of the City of San Luis, Arizona, authorizing and directing the city engineer to order the purchase of electricity and to order the maintenance of poles, luminaries and underground conduit incident to the installation of street lights for lighting public streets within the area described as Santa Cecilia No. 4 Subdivision, San Luis, Arizona. **(Jose A. Guzman, Director of Planning & Zoning)**
- 6. J.** Discussion and possible action on any and all matters regarding Resolution No. 2116. A resolution of the Mayor and City Council of the City of San Luis, Arizona, authorizing and directing the city engineer to order the operation and maintenance of certain retention basins for the area described as Santa Cecilia No. 4 Subdivision, San Luis, Arizona. **(Jose A. Guzman, Director of Planning & Zoning)**
- 6. K.** Discussion and possible action on any and all matters regarding Resolution No. 2117. A resolution of the Mayor and City Council of the City of San Luis, Arizona, authorizing and ordering the operation, maintenance and repair of certain landscape improvements included within, near and adjacent to the retention and detention basins and parkings and parkways and related facilities together with pertinent structures for the area described as Santa Cecilia No. 4 Subdivision, San Luis, Arizona. **(Jose A. Guzman, Director of Planning & Zoning)**

7. SUMMARY OF CURRENT EVENTS

Events by Mayor, Council Members and/or City Manager pursuant to A.R.S. §38-431.02 (K).

8. CALL TO THE PUBLIC

This is the time for the public to comment. Members of the City Council may not discuss items that are not specifically identified on the agenda. Therefore, pursuant to A.R.S. §38-431.01 (H), action taken as a result of public comment will be limited to directing staff to study the matter, responding to any criticism or scheduling the matter for further consideration and decision at a later date.

9. ADJOURNMENT



PROCLAMATION

Regular City Council Meeting

4.

Meeting Date: 01/08/2020

Title:

PROCLAMATION

- Lung Cancer Awareness Year 2020

Attachments

Proclamation



Proclamation

OFFICE OF THE
MAYOR
CITY OF SAN LUIS

Lung Cancer Awareness Year 2020

WHEREAS, lung cancer is the second most commonly diagnosed form of cancer in both men and women in the United States and is the leading cause of cancer death in the country;

WHEREAS, more than 90 percent of people diagnosed with lung cancer smoked a pack of cigarettes daily for at least 30 years or two packs a day for 15 years. Prevention and early detection can significantly reduce the number of deaths from lung cancer;

WHEREAS, researchers, scientists and numerous non-profit organizations are dedicated to discovering the cure for lung cancer. During the year 2020, the Yuma Regional Medical Center Cancer Center, will join these efforts to prevent and detect lung cancer in early stages.

WHEREAS, Yuma Regional Medical Center Cancer Center recognizes that education is the best tool to overcome, the thousands of deaths added each year to lung cancer statistics, this give us hope for a better future.

NOW THEREFORE, Gerardo Sanchez, Mayor of the City of San Luis, hereby proclaims Year 2020 of Early Awareness and Detection of Lung Cancer in the City of San Luis, Arizona. I encourage all residents of this city to support the education, prevention, and treatment efforts of those who fight against this disease.

PASSED AND ADOPTED this _____ day of _____ 2020.

Gerardo Sanchez, Mayor

ATTEST:

Sonia Cornelio, City Clerk



AGENDA ITEM REVIEW FORM

Regular City Council Meeting

5. A.

Meeting Date: 01/08/2020

Summary

MINUTES OF

- Work Session held December 4, 2019
 - Regular Council meeting held December 11, 2019
 - Special Council meeting held December 23, 2019
-

Attachments

12/4/2019 WS
12/11/2019 RCM
12/23/2019 SCM

MINUTES
Work Session
San Luis City Council
San Luis Council Chambers
1090 E. Union Street
December 4, 2019
6:30 p.m.

1. **CALL TO ORDER/ROLL CALL:** Mayor Gerardo Sanchez called the Work Session meeting to order at approximately 6:33 p.m.

PRESENT: Mayor Gerardo Sanchez
Vice Mayor Maria Cecilia Cruz
Council Member Mario Buchanan Jr.
Council Member Africa Luna-Carrasco
Council Member Jose Ponce
Council Member Matias Rosales
Council Member Gloria Torres

OTHERS PRESENT: Tadeo A. De La Hoya, City Manager
Sonia Cornelio, City Clerk
Kay Marion Macuil, City Attorney
America Cano, Administrative Coordinator
Angel Ramirez, Fire Chief
Angelica Castro, Contracts and Grants Coordinator
Angelica Cifuentes, Purchasing Coordinator
Aracely De la Hoya, Senior Services Manager
Ashley Valle, Customer Service Representative
Axel Chayra, IT Technician
Ayleen Larios, Customer Service Representative
Carlos Cortes, Assistant Director of Finance
Crystal Fragozo, Administrative Coordinator
Debora Luna, Accountant
Derek Dueñas, Information Technology Manager
Diana Hernandez, Administrative Coordinator
Edgar Carbajal, Acting Human Resources Director
Edgar Esparza, Accounting Specialist
Elizabeth Garcia-Bonilla, Administrative Coordinator
Eulogio Vera, Director of Public Works
Fausto Gonzalez, Training and Programs Coordinator
Francia Alonso, Assistant to Council/PIO
Isaac Gutierrez, GIS Technician
Isidro Lopez, Fire Engineer
Ivan Gutierrez, Economic Development Assistant
Janet Taylor, Legal Secretary
Javier Gonzalez, Fire Captain
Jenny Torres, Economic Development Manager
Jenny Fernandez, Recreation Specialist

Jesus De Leon, Police Sergeant
Joaquin Campa, Building Official
Jonathan Dumadag, Senior IT Technician
Jose A. Guzman, Director of Planning & Zoning
Jose L. Cisneros, Administrative Coordinator
Leanna Beltran, Office Assistant
Lizandro Galaviz, Director of Parks & Recreation
Margarita Dominguez, Accounting Specialist
Maria Sabori, Risk Property Analyst
Maria Munoz, Human Resources Benefits Coordinator
Martha Jimenez, Building Inspector
Mary French-Jones, Grant Writer
Melissa Lopez, Deputy City Clerk
Michelle Boucher, Administrative Coordinator
Miguel Ramirez, Accountant
Monica Castro, Director of Finance
Nigel Reynoso, Police Lieutenant
Richard Bauermann, Fire Inspector
Roman Pacheco, Planning Technician
Rosalva Leon, Human Resources Technician
Roula Encinas, Accountant
Socorro Ayala, Police Records Clerk
Xochitl Lopez, Administrative Assistant
Cesar Neyoy, Bajo El Sol
Guillermina Fuentes, Resident
Lucy Lopez, San Luis AZ News
Maria Robles, Resident

Mayor Gerardo Sanchez thanked all those employees present during this meeting. He suggested moving agenda item 2.F. to be the first item to be discussed. He explained that items discussed during a Works Session are only for discussion, and no action is to be taken. There was no opposition from members of the City Council.

2. ITEMS FOR DISCUSSION ONLY:

2. F. Discussion and possible directions to staff on any and all matters regarding the City of San Luis 4/10s work schedule and its benefits. (Council Member Mario Buchanan Jr.)

Mr. Tadeo A. De La Hoya, City Manager, informed that the 2019 Local Government Salary & Benefits Survey was included in the agenda item, this survey was forwarded to each municipality by Mr. Ken Strobeck, Arizona League of Cities and Towns Executive Director. He explained that this survey shows that 21% out of the 91% of cities incorporated within the state of Arizona is in a 5/8's schedule, the rest are in mixed schedules between 4/10's and 5/8's. He informed that the city saves approximately 30% of utility costs and commodities, which is over \$50,000.00 a year or less, in the last 10 years the city has had a savings of \$500,000.00.

Furthermore, he added that there are approximately 500 customers a month that come in to pay their utilities between the hours of 7:00 a.m. and 8:00 a.m. and 5:00 p.m. and 6:00 p.m., and those residents have taken advantage of the extended hours.

Mayor Gerardo Sanchez stated that every year council received comments from members of the community that want the city to be open 5 days a week, but the current schedule began 10 years ago during the recession of 2008. This schedule was also designed as a benefit to the employees. He informed that there is another city planning on going with the same work schedule as San Luis.

Council Member Mario Buchanan Jr. mentioned that the reason he brought this item up for discussion is that he believes that it is time to review and discuss this matter and know where the city stands. He mentioned that there is no doubt that the services are provided, but that he believes that as public servants, the city should be open 5 days a week. He thanked all those employees present during this meeting and stated that by discussing this item, it does not mean that the work schedule will change.

Council Member Jose Ponce stated that he had not received any complaints about the work schedule. He indicated that it is healthy to discuss this item amongst the council and staff.

Council Member Matias Rosales stated that he is in favor of the 4/10's schedule. He mentioned that the complaints that he has received when there is a holiday and added that overall, employees do great. He mentioned that residents are under the impression that all employees are off on Friday's, but once they are explained that from the 200 plus employees, approximately 110 are only with the 4/10's schedule, they are ok.

Vice Mayor Maria Cecilia Cruz stated that her belief is that if employees are happy, they will produce great results, just like they are currently doing. She mentioned that sometimes there are unforeseen circumstances for employees to be out during a working day. She stated that she is for the 4/10's schedule, just like Council Members Jose Ponce and Matias Rosales.

Council Members Africa Luna-Carrasco and Gloria Torres stated that they are both in favor of the 4/10's schedule, as this is a great benefit to employees.

Mayor Gerardo Sanchez opened the item for discussion and invited employees to discuss this item and explained how the 4/10's works schedule benefits employees.

Mr. Isaac Gutierrez, GIS Technician, stated that he has been an employee for 15 years. He mentioned that the current work scheduled is a great benefit. He commented that a benefit that San Luis residents get is that offices are open before they get to work and after getting off work. He stated that the current work scheduled is a benefit that the city offers is very attractive to employees; this helps retain employment. He mentioned that as a single parent, being off on Fridays, he spends more time with his children. He added that when the city was open 5 days a week, residents were also complaining.

Council Member Matias Rosales mentioned that this is not only a benefit to the employees but to the community as approximately 35 residents daily take advantage of the current hours of operations.

Ms. Kay Marion Macuil, City Attorney, stated that the city has been expanding online services for the residents' convenience. She mentioned that the current schedule is a benefit and helps in the retention of employment.

Mr. Nigel Reynoso, Police Lieutenant, stated that the work schedule gives more flexibility at the time staff needs to cover events and lets staff spend more time with the family. He mentioned that 10 hours of work would never be enough time to get things done.

Mr. Eulogio Vera, Director of Public Works, mentioned that in his department, most of his employees work 5/8s and in the administration here are only three (3) staff members that work 4/10s. He stated that staff has expressed that the benefit of the 4/10s is that they get to spend more time with their family.

Mayor Gerardo Sanchez asked Mr. Vera if the department receives complaints from developers regarding the office schedule.

Mr. Vera replied that not from developers, the main complaints are that not obtaining their permits faster. His belief is that the permitting department provides excellent service by getting permits issued; most of the time the developers' expectation is to get things done within two (2) weeks of paperwork submittal, where anywhere else takes a month or 6 weeks. He informed that when inspections are required during the weekend, they are done. He stated that overall, services have been provided. Mr. Vera added that his department has received good comments from residents that require services before going to work and after work.

Ms. Xochitl Lopez, Administrative Assistant, Public Works Department, stated that even though the office is closed on Fridays, the services are being provided just like Mr. Vera mentioned. She mentioned the benefit of being off on Fridays gives her more time to spend with her two (2) elderly parents, takes them to doctor appointments, etc. She asked Mayor and Council to please consider the employees and leave the work schedule as it is.

Ms. Jenny Torres, Economic Development Manager, mentioned that employees are public servants and are here to serve the community. She stated that the community is being provided with the services they request. She mentioned that the employees are the city's biggest asset and this is a great benefit and added that her department supports the 4/10s schedule.

Mr. Lizandro Galaviz, Director of Parks & Recreation, informed that his department is split out in 4/10s and 5/8s to serve the community's and city's needs. He stated that the 4/10s have been beneficial for the different divisions in the Parks & Recreation department. He added that during holidays and events, employees are there after hours, supporting the department and the city. He stated that since the events are pre-planned, that gives the opportunity to set up schedules. He mentioned that he agrees that the current work schedule is a benefit, and employees are able to schedule appointments and do personal errands on Friday's.

Council Member Matias Rosales asked Mr. Galaviz if the work schedule were to be changed to 5/8s, would the department be tied up.

Mr. Galaviz replied that the overtime would have to be increased because currently the department works those extra hours in the preparation of events.

Mayor Gerardo Sanchez stated that one of the main ideas of the 4/10 schedule was to reduce overtime. He mentioned that he understands that there is certain departments that are required to pay overtime to their employees. He asked if there are any employees that are for the 5/8s work schedule. He thanked employees the been present during this meeting. He stated that the work schedule is because the city wants to save money and provide a benefit to employees.

There were no employees present that support the 5/8s work schedule.

Council Member Mario Buchanan Jr. thanked all employees for addressing the council on this issue, as this was a productive meeting. He mentioned that he learned more about employees; this helps understand the needs of employees and the community.

Mayor Gerardo Sanchez stated that the consensus after this discussion is that the work schedule will remain the same. He clarified that this item was just a discussion and no decisions were made.

2. A. Discussion and possible directions to staff on any and all matters regarding a contract with Berkeley Research Group, LLC., associated with the Development of Feasibility Study for Natural Gas in San Luis, Arizona. (ITEM CONTINUED FROM SPECIAL COUNCIL MEETING HELD NOVEMBER 26, 2019). (Jenny Torres, Economic Development Manager)

Ms. Jenny Torres, Economic Development Manager, informed that this is a technical assistance grant in the amount of \$161,050.00 from the Northern American Development Bank (NADB); the city's match will be \$17,894.00 (10%) of the total cost of \$178,944.00. She stated that this grant will help develop a study that will review and evaluate the feasibility of developing a project to install necessary infrastructure for natural gas supply and distribution grid in the east side of San Luis, AZ and San Luis Rio Colorado, Sonora, Mexico. Ms. Torres stated that staff received three (3) proposals from qualified firms, the most responsible bidder was Galoway Group from Texas. This company was purchased from Berkeley Research, LLC, from Delaware. She mentioned that this was the reason for the project delay in negotiating the contract, staff and the company has agreed to the terms of the contract, for this reason, the item has been introduced during this meeting. She informed that staff had not received any protest letter from the other companies; for this reason, staff is recommending awarding the contract to Berkeley Research Group, LLC.

Vice Mayor Maria Cecilia Cruz thanked Ms. Torres for working with Mexico to get this project going.

Ms. Torres stated that this project is a portion of a utility corridor that the region is working on; this corridor will include broadband, natural gas, rail, and a transmission line.

Mayor Gerardo Sanchez also thanked Ms. Torres and her staff for a great job. He stated that this is something that will help not only the city but also industries.

2. B. Discussion and possible directions to staff on any and all matters regarding the purchase of three (3) shades for the Joe Orduño Park playground. (Lizandro Galaviz, Director of Parks & Recreation)

Mr. Lizandro Galaviz, Director of Parks & Recreation, clarified that staff would be purchasing three (3) structures for one (1) playground. He mentioned that it is more feasible to purchase three (3) independent structures than purchasing one single structure for the entire playground. This shade structure will help during the summer and will help with the care of the equipment. He stated that with the approval of fiscal year 2019-2020 budget, City Council approved the purchase of these structures, which also included LED lights.

Mayor Gerardo Sanchez directed Mr. Galaviz to proceed with this item.

2. C. Discussion and possible directions to staff on any and all matters regarding entering into a construction contract with Cemex Construction Materials South, LLC for the Rancho Los Oros Roadway Improvements Project (CDBG Contract #113-20). (Mary French-Jones, Grant Writer)

Ms. Mary French-Jones, Grant Writer, informed that staff issued a Request for Proposal in October 2019, a non-mandatory pre-bid conference was held on November 5, 2019, and conducted the bid opening on November 14, 2019. Staff received two (2) bids, after engineer review, they recommended the lowest most responsible bidder who was Cemex Construction Materials South, LLC. She informed that staff budgeted for this item. She added that staff is aiming to start construction in January 2020.

Mayor Gerardo Sanchez directed Ms. French-Jones to proceed with this item.

2. D. Discussion and possible directions to staff on any and all matters regarding a contract with James Davey and Associates, Inc. associated with the design of Rancho Los Oros Improvements - Phase II. (Mary French-Jones, Grant Writer)

Ms. Mary French-Jones, Grant Writer, informed that there are not enough funds to make the improvement in the entire subdivision. The item discussed before this item is to do the more critical infrastructure needs, and phase II staff would like to plan ahead for this reason staff would like to hire James Davey and Associates, Inc to prepare information for funding submittal in the future.

Mayor Gerardo Sanchez directed Ms. French-Jones to proceed with this item.

2. E. Discussion and possible directions to staff on any and all matters regarding the purchase of seven (7) new cardiac monitors. (Angel Ramirez, Fire Chief)

Mr. Angel Ramirez, Fire Chief, informed that this item was discussed during the budget retreat.

He mentioned that staff is currently having some issues with the Philips HeartStart MRx M3535A cardiac monitor. He added that the Philips company itself had endured several issues with the Food and Drug Administration (FDA), where the maintenance needed is not being received. He stated that this equipment is used on a daily basis; this equipment is very valuable to the department. He informed that staff reached out to two (2) of the nation's most reputable cardiac monitoring companies, ZOLL and Medtronic, after several field trials, staff decided on ZOLL Series X Model. He mentioned that staff would be using the City of Tucson contract, which was obtained through competitive bidding for this equipment. The total cost will be \$294,000.00.

Mayor Gerardo Sanchez commented that Council has invested in the best equipment that can be afforded in regards to the Fire Department, it will be counterproductive if staff purchases the cheapest and most affordable unit that will not provide accurate readings. Mayor Gerardo Sanchez directed Mr. Ramirez to proceed with this item.

2. G. Discussion and possible directions to staff on any and all matters regarding a proposed city ordinance that increases the minimum legal sale age for tobacco products from 18 to 21 to include cigarettes, e-cigarettes, chewing tobacco, snuff, snus, and liquids used in electronic smoking devices. (Council Member Africa Luna-Carrasco; Kay Marion Macuil, City Attorney)

Council Member Africa Luna-Carrasco stated that the reason she brought this item for discussion is that tobacco products cause a lot of preventable diseases among the users, especially youth, and up until the age of 21 becomes more addictive, and the adolescent brain is more susceptible. She stated that finding out this information, and it brought her concern. She mentioned that the City Council should do something about this issue and help the youth.

Ms. Kay Marion Macuil, City Attorney, informed that this year this issue came out, this topic brought a preemption statute in the senate, but it did not pass in the House of Representatives of Arizona. She informed that the city is not preempted in doing so if that what Council desires.

Council Member Africa Luna-Carrasco stated that she included e-cigarettes because this issue has been continuously growing.

Mayor Gerardo Sanchez agreed with Council Member Africa Luna-Carrasco and stated that there has to be age limits. He mentioned that this topic is being challenged in courts.

Ms. Macuil informed that Buckeye and Tucson had passed a law about this topic.

Mayor Gerardo Sanchez directed the City Attorney to review other ordinances and get back to Council.

2. H. Discussion and possible directions to staff on any and all matters regarding the idea of planting trees along County 22nd Street from 4th Avenue to 8th Avenue in the attempt to beautify and improve livability in the city. (Council Member Africa Luna-Carrasco; Eulogio Vera, Director of Public Works; and Lizandro Galaviz, Director of Parks & Recreation)

Council Member Africa Luna-Carrasco mentioned that if trees are planted along County 22nd Street from 4th Avenue to 8th Avenue, it will look better and also will help the environment. She informed that she was reached out by some residents expressing their concern. She commented that trees would help with climate change and provide more oxygen. She informed that if this cannot be done this fiscal year, maybe this can be added in the next budget. She added that one idea would have members of the community donate a tree.

Mayor Gerardo Sanchez stated that the city should be planting more trees in the community. He mentioned that there is currently a problem along Cesar Chavez Boulevard, where you can see dried trees. He stated that he understands that trees are expensive to maintain, but this is something that has to be done.

Mr. Eulogio Vera, Director of Public Works, informed that one of the challenges that the city needs to overcome on this street and other streets in the city is that the city does not have the right-of-way. One of the issues is that County 22nd Street is in the Capital Improvement Plan to widen the road from 10th Avenue to Main Street. He mentioned that to obtain the right-of-way is a big challenge as the canal is on the south and farm field on both sides. He stated that if the city is to acquire the right-of-way, this project could be accomplished.

Council Member Gloria Torres asked Mr. Lizandro Galaviz, Director of Parks & Recreation, about the project with PPEP regarding trees.

Mr. Lizandro Galaviz, Director of Parks & Recreation, informed that staff has several projects they are currently working on, one is a nursery project in conjunction with PPEP Youthbuild. He added a couple of months ago, his department partnered with Rio Colorado Elementary School and planted approximately 20 trees on the west side of town in some of the retention basins that were lacking trees. He mentioned that it is very important where plants are planted because re-rooting an adult tree is very difficult; they will die or get diseases. He added that it is important that when staff selects an area, the planted trees are going to stay in that location permanently.

Mayor Gerardo Sanchez commented that in a city the same size as San Luis needs between 228-260 acres of green areas; currently, the city has 50 acres of green areas. He asked staff to proceed and to include this project in the next fiscal year budget.

Ms. Maria Robles, San Luis resident, thanked Mayor and Council Member for bringing this item for discussion. She mentioned that there is currently a project called "Jugemos Limpio" this is to have clean air and green areas in the homes and community.

2. I. Discussion and possible directions to staff on any and all matters regarding an update from the San Luis Police Department on community policing efforts. (Council Member Africa Luna-Carrasco and Richard Jessup, Chief of Police)

Council Member Africa Luna-Carrasco mentioned that the reason this item was placed on the agenda is that the San Luis Police Department events have been dormant, there has not been an emphasis on them as in the past. She commented that the only event in social media is Coffee with a Cop, as in the past, there was a Clean-up Capaing, Graffiti Abatement, Car Seat, and others.

Mr. Nigel Reynoso, Police Lieutenant, presented Mayor and Council with a list of events held in 2019. He agreed with Council Member Africa Luna-Carrasco and mentioned that the reason some of the past events have been postponed or canceled is that the department has been focusing more on kids at schools, because of the increase of drugs at schools. He informed that two (2) of the programs that the department would like to start is the Neighborhood Watch and a drug prevention program at schools.

Mayor Gerardo Sanchez thanked the Police Department for the great job they do. He mentioned that he understands the need for manpower in this department. He commented that this year, San Luis and other communities had a big problem with Fentanyl usage amongst youth, one of the complaints was that the Police Department was doing not enough to prevent this problem. He stated that the community needs to feel secure and hold other events to get closer to the community so that they can feel protected and trust Police Officers. Mayor Gerardo Sanchez stated that he would like to see Police Officers doing bike policing like they used to do; this program made a difference in the community. He added that the Neighborhood Watch Program is very much needed as crime statistics are going up.

Lieutenant Reynoso stated that currently, there are no assigned officers, staff is getting ready to go through the selection process for two (2) new officers. He informed that the reason the bikespolicing is no longer in existence is because those officers were placed in vehicles, they were needed to patrol the community. He commented that the Police Department is open for suggestions. He mentioned that the Police Department wants to be closer to the community and give confidence to the community.

Council Member Africa Luna-Carrasco asked what the status of the School Resource Officer (SRO) at schools is.

Lieutenant Reynoso replied that there is currently one (1) SRO in the San Luis High School and it alternates between two (2) officers. He added that Gadsden School District is currently working on a grant to obtain two (2) officers for the two (2) different Middle Schools.

Council Member Matias Rosales asked if the San Luis Police Department has Community Support Officers (CSO).

Lieutenant Reynoso replied that currently, the department does have any CSO due to a lack of funding. He added that in the past, there was an officer that was assigned to the department programs, but at this time, there is no one assigned to fulfill that role.

Council Member Matias Rosales asked staff to consider the CSO in the next fiscal year budget.

3. ADJOURNMENT

MOTION: Council Member Mario Buchanan Jr./Council Member Africa Luna-Carrasco to adjourn the meeting at approximately 8:00 p.m. Motion passed unanimously.

The vote was as follows:

Vice Mayor Maria Cecilia Cruz	Aye
Council Member Mario Buchanan Jr.	Aye
Council Member Africa Luna-Carrasco	Aye
Council Member Jose Ponce	Aye
Council Member Matias Rosales	Aye
Council Member Gloria Torres	Aye

APPROVED:

Gerardo Sanchez, Mayor

ATTEST:

Sonia Cornelio, City Clerk

Certification

I hereby certify that the foregoing minutes are a true and correct copy of the minutes of the Work Session for the City Council of the City of San Luis, Arizona, held on December 04, 2019. I further certify that the meeting was duly called and held and that a quorum was present.

Sonia Cornelio, City Clerk

MINUTES
Regular Council Meeting
San Luis City Council
San Luis Council Chambers
1090 E. Union Street
December 11, 2019
7:00 p.m.

1. CALL TO ORDER/ROLL CALL: Mayor Gerardo Sanchez called the Regular City Council meeting to order at approximately 7:00 p.m.

PRESENT: Mayor Gerardo Sanchez
Vice Mayor Maria Cecilia Cruz (telephonically)
Council Member Mario Buchanan Jr.
Council Member Africa Luna-Carrasco
Council Member Jose Ponce
Council Member Matias Rosales

ABSENT: Council Member Gloria Torres

OTHERS PRESENT: Tadeo A. De La Hoya, City Manager
Sonia Cornelio, City Clerk
Kay Marion Macuil, City Attorney
Angel Ramirez, Fire Chief
Derek Dueñas, IT Manager
Edgar Carbajal, Acting Human Resources Director
Enrique Lopez, Assistant Fire Chief
Eulogio Vera, Director of Public Works
Jenny Torres, Economic Development Manager
Jonathan Dumadag, Senior IT Technician
Jorge Perez, Billing & Collections Manager
Jose A. Guzman, Director of Planning & Zoning
Lizandro Galaviz, Director of Parks & Recreation
Mary French-Jones, Grant Writer
Monica Castro, Director of Finance
Richard Jessup, Chief of Police
Roman Pacheco, Planning Technician
Buna George, Yuma Greater Port Authority
Cesar Neyoy, Reporter
Christian Cuevas, Simultaneous Interpreter
Edie Loo, Developer
Gerald Hunt, Attorney
Lucy Lopez, Reporter
Maria Robles, Resident
Najeh Edais, Riedel Holdings Engineer
Vianey Vega, Vega & Vega Engineering

2. PLEDGE OF ALLEGIANCE

The Pledge of Allegiance was led by Council Member Matias Rosales.

3. INVOCATION

The invocation was led by Mr. Richard Jessup, Chief of Police.

4. CONSENT AGENDA

4. A. MINUTES OF

- Work Session held November 20, 2019

4. B. DISBURSEMENTS FROM NOVEMBER 16, 2019 THROUGH NOVEMBER 30, 2019.

Total Disbursements \$862,164.53

(Eight Hundred Sixty-Two Thousand, One Hundred Sixty-Four Dollars and Fifty-Three Cents)

4.C. Discussion and possible action on any and all matters regarding entering into a construction contract with Cemex Construction Materials South, LLC for the Rancho Los Oros Roadway Improvements Project (CDBG Contract #113-20). **(Mary French-Jones, Grant Writer)**

4.D. Discussion and possible action on any and all matters regarding a contract with James Davey and Associates, Inc. associated with the design of Rancho Los Oros Improvements - Phase II. **(Mary French-Jones, Grant Writer)**

4.E. Discussion and possible action on any and all matters regarding a contract with Berkeley Research Group, LLC., associated with the Development of Feasibility Study for Natural Gas in San Luis, Arizona. **(Jenny Torres, Economic Development Manager)**

MOTION: Council Member Matias Rosales/Council Member Jose Ponce to approve the Consent Agenda as presented. Motion passed unanimously.

The vote was as follows:

Mayor Gerardo Sanchez	Aye
Vice Mayor Maria Cecilia Cruz	Aye
Council Member Mario Buchanan Jr.	Aye
Council Member Africa Luna-Carrasco	Aye
Council Member Jose Ponce	Aye
Council Member Matias Rosales	Aye

5. DISCUSSION AND POSSIBLE ACTION ITEMS:

5.A. Public hearing followed by discussion and possible action on any and all matters regarding Major General Plan Amendment Case No. 2019-0394 and Resolution No. 2109. A resolution of the Mayor and City Council of the City of San Luis amending the 2020 General Plan to change the land use designation of approximately 164.76 acres of land located on the northeast corner of Avenue E and County 24th Street from Business and Industrial to Neighborhood; repealing any conflict provisions; and providing for severability. **(Jose A. Guzman, Director of Planning & Zoning)**

A. Open public hearing

MOTION: Council Member Matias Rosales/Council Member Africa Luna-Carrasco to open the public hearing. Motion passed unanimously.

The vote was as follows:

Mayor Gerardo Sanchez	Aye
Vice Mayor Maria Cecilia Cruz	Aye
Council Member Mario Buchanan Jr.	Aye
Council Member Africa Luna-Carrasco	Aye
Council Member Jose Ponce	Aye
Council Member Matias Rosales	Aye

1. Staff presentation

Mr. Jose Guzman, Director of Planning & Zoning, explained that this request is for a major general plan amendment submitted to the city in June 2019 by Edais Engineering. The request is to amend the land use designation on 164.76 acres from Business and Industrial to Neighborhood; the purpose is to allow residential subdivisions. The location is between Avenue E and Avenue D and County 24th Street and San Luis Lane. The city is currently working on the General Plan update with Matrix Design Group and they are recommending to take no action on these items or not approve any amendment at the moment as the city is in the process of the General Plan update and any changes can alter the results on the resources of the city. Staff recommends to deny the application.

2. Call to the Public on this item

Mr. Gerry Hunt, Attorney and former City of San Luis Attorney, said that Mr. Stephen Shadle, Mr. Najeh Edais and himself, are concerned that with a major general plan amendment, a four (4) vote from the City Council is needed. The zoning request is the one where they can put conditions on the zoning such as a buffer zone between a prison and residential properties, however, these are situations that can be developed at a later date, the first step is to get the general plan done. Many of the property owners have been waiting for this land to be developed for years. He is very proud that one of his clients, Ms. Amanda Aguirre, has invested \$35 million in that particular area for the medical mall.

Mr. Steven P. Shadle would like to see some development while he is still here to see it. Mr. Hunt added that he hopes the City Council considers the four (4) votes on this request.

Mr. Najeh Edais, Edais Engineering, stated that there needs to be a good road system for their trucks to travel from the border to its destination. His product does not stop in San Luis or Yuma, his product goes mostly to California. He wants Avenue E to be good for trucks and trucking and he wants the industry to flourish in San Luis. The City of San Luis needs industry and it cannot be accomplished without having the manpower and to have the manpower the city needs to provide housing and there is not much land left for housing but there is plenty of industrial land south of County 24th Street. He thinks that anything south of County 24th Street should remain industrial but anything between County 24th Street and County 23rd Street should be converted to residential. Studies are good, as they are guides to direct in one way or another but are not set in stone and one can determine what is good for the community. They want to build a shopping center and a truck stop that supports all of the trucking activity. If the concern is the prison or the wastewater treatment plant, it does not mean that it will be built all the way to the prison or the wastewater treatment plant. There are a lot of things to think about and hopes that the City Council considers the needs of the community.

Mr. Steven P. Shadle, owner, mentioned that he has had a number of appraisal, some of which have resulted in residential use, his preliminary plan inputs residential, apartments and condos which was approved by the City Council. He is asking that the residential use zoning be expanded. He has waited over 20 years for this use to come along. It is approximately 60 acres he is requesting to be changed; there will still be commercial use on Avenue B and County 24th Street. In talking with Ms. Nieves Riedel, they want to build a shopping center and possibly a major gas station or a truck stop. Therefore, that commercial would be developed as soon as they can and also residential construction would not be built immediately. One thing he wanted to remind the City Council is when Glenn Gimbut came in several years ago, he said that Mr. Shadle had bought all that property and the city would like some property to go through the city to build the water and sewer plant, and they liked an easement for the water lines and he cooperated with the city as best as he could and the sewer and water plant was built in his property on fair terms. The City Council thanked him and did not complain at that time for allowing the city to place the water and sewer line in his property, but now the city wants to deny the requested use of this property. He added that he donated 150 palm trees to the city but Glenn Gimbut was never able to find the money to improve the median along Avenue E. Some people from the prison have requested that a residential area be developed near that area so that they can live there so that they would not commute to town or Yuma. Mr. Shadle asked the City Council to consider their proposal.

Ms. Kay Macuil, City Attorney, made a correction on the statement made by Mr. Hunt earlier, regarding the number of votes needed; it requires two thirds of votes to pass a major plan amendment, so that would be six (6) votes, not four (4).

B. Close public hearing

MOTION: Council Member Mario Buchanan Jr./Council Member Matias Rosales to close the public hearing. Motion passed unanimously.

The vote was as follows:

Mayor Gerardo Sanchez	Aye
Vice Mayor Maria Cecilia Cruz	Aye
Council Member Mario Buchanan Jr.	Aye
Council Member Africa Luna-Carrasco	Aye
Council Member Jose Ponce	Aye
Council Member Matias Rosales	Aye

C. Action on Resolution No. 2109

MOTION: Council Member Mario Buchanan Jr./Council Member Africa Luna-Carrasco to deny approval of Resolution No. 2109. Motion passed unanimously.

The vote was as follows:

Mayor Gerardo Sanchez	Aye
Vice Mayor Maria Cecilia Cruz	Aye
Council Member Mario Buchanan Jr.	Aye
Council Member Africa Luna-Carrasco	Aye
Council Member Jose Ponce	Aye
Council Member Matias Rosales	Aye

5.B. Public hearing followed by discussion and possible action on any and all matters regarding Major General Plan Amendment Case No. 2019-0395 and Resolution No. 2110. A resolution of the Mayor and City Council of the City of San Luis amending the 2020 General Plan to change the land use designation of approximately 18.44 acres of land located on the southeast corner of 20th Avenue and County 24th Street from Business to Neighborhood; repealing any conflict provisions; and providing for severability. **(Jose A. Guzman, Director of Planning & Zoning)**

A. Open public hearing

MOTION: Council Member Mario Buchanan Jr./Council Member Jose Ponce to open the public hearing. Motion passed unanimously.

The vote was as follows:

Mayor Gerardo Sanchez	Aye
Vice Mayor Maria Cecilia Cruz	Aye
Council Member Mario Buchanan Jr.	Aye
Council Member Africa Luna-Carrasco	Aye
Council Member Jose Ponce	Aye

Council Member Matias Rosales Aye

1. Staff presentation

Mr. Jose A. Guzman, Director of Planning & Zoning, informed that this is a request to change the land use designation from Business to Neighborhood in order to develop a residential subdivision. As stated in the previous item, Matrix Design is working on the General Plan update and their recommendation is not to move forward with any changes prior to the update, therefore staff recommends denial of this item.

2. Call to the Public on this item

Mr. Vianey Vega, Vega & Vega Engineering, expressed that this surprises him as he followed the directions given by staff to proceed with this project. This project consists of two (2) phases; the residential subdivision which are 40 acres located south of County 24th Street and Avenue E ½. He added that he met with staff to discuss this project and submitted the application and was directed to split the 40 acre property into two 20 acre pieces of land so that the first phase could be developed with a minor amendment, which was done. They did a minor amendment and a rezoning and then the plat followed the process, the plat was approved and construction began a couple of weeks, the land has been graded, they are to obtain permits to start the underground. It is a total of 20 acres, 91 lots have been built. Mr. Vega explained the map illustrated during the council meeting and included on the agenda packet filed at the City Clerk's Office. The second phase is to submit the major amendment as the total acreage is 40, so it triggered the major amendment and the petition was submitted. He is requesting the approval of this major amendment to continue the residential subdivision as planned and as directed by staff. There is a half way road to the north side that is going to be developed with the phase under construction and the project was approved like that because the understanding was that the second phase would complete the other half of the road. If it is denied there will be a half a road that is unknown when it will be built.

Mr. Tadeo A. De La Hoya, City Manager, stated that when phase one was done, phase two was in the plan. The applicant was aware a major amendment was going to be triggered at the moment and the applicant decided to do a rezoning rather than a general plan amendment when they should of have it done.

Council Member Matias Rosales asked if the major plan amendment for Case Number 2019-0395 the other parcels are not included.

Mr. De La Hoya responded that in section of this subdivision, they knew that it was going to trigger a major plan amendment so the applicant decided to go through a rezoning for phase one knowing that it might trigger a major plan amendment and they were offered to do the major plan amendment which at that time it could have been done on time to have it incorporated to the general plan study.

Council Member Matias Rosales commented that if the major amendment is being requested on phase two of the subdivision, which already has phase one, not included on the parcels to the east of Avenue E.

Mr. Guzman said it was a separate case and explained the map illustrated, and as a clarification, staff does not provide any direction to the developers or engineers but want to make sure that they follow the regulations. They came in for 40 acres and they were advised that it was a major amendment and that they had to submit the case in June and it would be voted upon in November or the end of the year. A minor amendment is anything less than 20 acres and that is the way they decided to move forward with. Staff did tell them that it was not guaranteed that the south 20 acres were going to be approved and that the south 20 acres was going to trigger the major amendment.

Mayor Gerardo Sanchez asked how the Planning & Zoning Commission voted on this item. Mr. Guzman replied that the Planning & Zoning Commission recommended approval, also staff recommended approval but after doing more research and the recommendation from Matrix, staff changed the recommendation to denial until the General Plan update is completed.

Mr. De La Hoya added that applications as per the letter from Matrix will be incorporated to the research of their doing into the General Plan update.

Council Member Matias Rosales asked if Matrix is assuming that this is also part of the 640 acres that got withdrew and that is the reason they recommended that, had they known that these are 20 acres left of phase two, would they have recommended the same. Mr. Guzman replied that Matrix is aware of the situation and that they are different cases.

Mr. Vega said that this case was presented to the Planning & Zoning Commission and their recommendation was approval as well as staff's. He was notified that staff had changed its recommendation for denial. Mr. De La Hoya replied that Ms. Elizabeth Carpenter met with him and she was informed. Mr. Vega mentioned that he is the applicant and would have appreciated if he had been informed of any changes.

Mayor Gerardo Sanchez commented that this is only 20 acres and his concern is when the whole area is changed, 20 acres will not make a major impact on infrastructure in the future.

Mr. Guzman recommended denial of this request or continuing the item until the general plan update is complete.

Council Member Matias Rosales stated that the letter of Matrix says the general plan update will be completed early 2020 and asked what early 2020 is for Matrix. Mr. Guzman responded that the draft will be done probably by March 2020.

Mayor Gerardo Sanchez mentioned that they have already began this subdivision and they should be allowed to finish it, Council Member Matias Rosales agreed.

B. Close public hearing

MOTION: Council Member Matias Rosales/Council Member Mario Buchanan Jr. to close the public hearing. Motion passed unanimously.

The vote was as follows:

Mayor Gerardo Sanchez	Aye
Vice Mayor Maria Cecilia Cruz	Aye
Council Member Mario Buchanan Jr.	Aye
Council Member Africa Luna-Carrasco	Aye
Council Member Jose Ponce	Aye
Council Member Matias Rosales	Aye

C. Action on Resolution No. 2110

MOTION: Council Member Jose Ponce/Council Member Matias Rosales to approve Resolution No. 2110. Motion passed unanimously.

The vote was as follows:

Mayor Gerardo Sanchez	Aye
Vice Mayor Maria Cecilia Cruz	Aye
Council Member Mario Buchanan Jr.	Aye
Council Member Africa Luna-Carrasco	Aye
Council Member Jose Ponce	Aye
Council Member Matias Rosales	Aye

5.C. Public hearing followed by discussion and possible action on any and all matters regarding Major General Plan Amendment Case No. 2019-0396 and Resolution No. 2111. A resolution of the Mayor and City Council of the City of San Luis amending the 2020 General Plan to change the land use designation of approximately 493 acres of land located on the southeast corner of County 24th Street and Avenue D. **(Jose A. Guzman, Director of Planning & Zoning)**

A. Open public hearing

MOTION: Council Member Mario Buchanan Jr./Council Member Matias Rosales to open the public hearing. Motion passed unanimously.

The vote was as follows:

Mayor Gerardo Sanchez	Aye
Vice Mayor Maria Cecilia Cruz	Aye
Council Member Mario Buchanan Jr.	Aye
Council Member Africa Luna-Carrasco	Aye
Council Member Jose Ponce	Aye
Council Member Matias Rosales	Aye

1. Staff presentation

Mr. Jose Guzman, Director of Planning & Zoning, explained that he received the request from the applicant to withdraw this application.

2. Call to the Public on this item

B. Close public hearing

MOTION: Council Member Mario Buchanan Jr./Council Member Jose Ponce to close the public hearing. Motion passed unanimously.

The vote was as follows:

Mayor Gerardo Sanchez	Aye
Vice Mayor Maria Cecilia Cruz	Aye
Council Member Mario Buchanan Jr.	Aye
Council Member Africa Luna-Carrasco	Aye
Council Member Jose Ponce	Aye
Council Member Matias Rosales	Aye

C. Action on Resolution No. 2111

No action was taken as applicant withdrew the application.

6. SUMMARY OF CURRENT EVENTS

Mayor Gerardo Sanchez reported that he participated in El Dia Del Campesino which resulted in a good turn out. He also attended the special mass at 4:00 a.m. the day prior. It was a good event and it was the last official event held at Friendship Park. If the presidential budget gets approved, the Friendship Park will become federal land property. He also attend the Christmas lighting event, it was a beautiful event despite the rain, there were approximately 1,500 attendees. The light parade will take place tomorrow, December 12, 2019 and invited everyone present to attend. The city employees recognition event will take place Friday, December 13, 2019.

Vice Mayor Maria Cecilia Cruz reported she also attended El Dia de Campesinos at 1:00 a.m., she thanked Campesinos Sin Frontera for this event.

Council Member Matias Rosales reminded everyone of tomorrow's Christmas light parade at 6:00 p.m.

7. CALL TO THE PUBLIC

Ms. Diane Umphress, Director of Amberly's Place, wished the Mayor and City Council a Merry Christmas and thanked them for the continued support provided to this agency.

8. ADJOURNMENT

MOTION: Council Member Matias Rosales/Council Member Jose Ponce to adjourn the Regular Council meeting at approximately 8:00 p.m. Motion passed unanimously.

The vote was as follows:

Mayor Gerardo Sanchez	Aye
Vice Mayor Maria Cecilia Cruz	Aye
Council Member Mario Buchanan Jr.	Aye
Council Member Africa Luna-Carrasco	Aye
Council Member Jose Ponce	Aye
Council Member Matias Rosales	Aye

APPROVED:

Gerardo Sanchez, Mayor

ATTEST:

Sonia Cornelio, City Clerk

CERTIFICATION

I HEREBY CERTIFY THAT THE FOREGOING MINUTES ARE A TRUE AND CORRECT COPY OF THE MINUTES OF THE REGULAR CITY COUNCIL MEETING FO THE CITY COUNCIL, SAN LUIS, ARIZONA HELD ON DECEMBER 11, 2019. I FURTHER CERTIFY THAT THE MEETING WAS DULLY CALLED AND HELD AND THAT A QUORUM WAS PRESENT.

Sonia Cornelio, City Clerk

MINUTES
Special Council Meeting
San Luis City Council
San Luis Council Chambers
1090 E. Union Street
December 23, 2019
6:30 p.m.

1. CALL TO ORDER/ROLL CALL: Mayor Gerardo Sanchez called the Regular City Council meeting to order at approximately 6:32 p.m.

PRESENT: Mayor Gerardo Sanchez
Council Member Matias Rosales-arrived at approximately 6:36 p.m.
Council Member Africa Luna-Carrasco
Council Member Jose Ponce
Council Member Gloria Torres-left the meeting at approximately 7:17 p.m.

ABSENT: Vice Mayor Maria Cecilia Cruz
Council Member Mario Buchanan Jr.

OTHERS PRESENT: Tadeo A. De La Hoya, City Manager
Sonia Cornelio, City Clerk
Kay Marion Macuil, City Attorney
Angel Ramirez, Fire Chief
Angelica Roldan, Assistant Director of Parks & Recreation
Carlos Cortez, Assitant Director of Finance
Edgar Carbajal, Acting Human Resources Director
Enrique Lopez, Assitant Fire Chief
Eulogio Vera, Director of Public Works
Francia Alonso, Assistant to Council/PIO
Gilberto Torres, Wastewater Supervisor
Jonathan Dumadag, IT Technician
Jorge Mungaray, IT Technician
Jorge Perez, Billing & Collections Manager
Jose A. Guzman, Director of Planning & Zoning
Lizandro Galaviz, Director of Parks & Recreation
Marco Santana, Police Lieutenant
Christian Cuevas, Simultaneous Interpreter
Cesar Neyoy, Reporter
Eddie Loo, Developer
Elizabeth Carpenter, Developer
Lucy Lopez, Reporter

2. PLEDGE OF ALLEGIANCE

The Pledge of Allegiance was led by Council Member Jose Ponce.

3. INVOCATION

The invocation was performed by Mr. Tadeo A. De La Hoya, City Manager.

4. CONSENT AGENDA

4.A. MINUTES OF

- Special Council meeting held November 26, 2019

4.B. DISBURSEMENTS FROM DECEMBER 1, 2019 THROUGH DECEMBER 13, 2019.

Total Disbursements \$989,528.03

(Nine Hundred Eighty-Nine Thousand, Five Hundred Twenty-Eight Dollars and Three Cents)

4.C. Discussion and possible action on any and all matters regarding the purchase of seven (7) new cardiac monitors. (Angel Ramirez, Fire Chief)

4.D. Discussion and possible action on any and all matters regarding the purchase of three (3) shade structures for the Joe Orduño Park. (Lizandro Galaviz, Director of Parks & Recreation)

MOTION: Council Member Gloria Torres/Council Member Africa Luna-Carrasco to approve the Consent Agenda as presented. Motion passed unanimously.

The vote was as follows:

Mayor Gerardo Sanchez	Aye
Council Member Africa Luna-Carrasco	Aye
Council Member Jose Ponce	Aye
Council Member Matias Rosales	Aye
Council Member Gloria Torres	Aye

DISCUSSION AND POSSIBLE ACTION ITEMS:

5.A. Discussion and possible action on any and all matters regarding the appointment of Council Member Jose Ponce to serve on the Regional Council on Aging - Area Agency on Aging Advisory Council of the Western Arizona Council of Governments (WACOG). (Francia Alonso, Assistant to Mayor and Council/PIO)

Ms. Francia Alonso, Assistant to Council/PIO, said that in September 2019, WACOG notified the city that there was a vacancy in the Regional Council on Aging, since then, Council Member Jose Ponce has expressed his interest in serving on this board. The last member to serve on this board was Mr. Agustin Rodriguez, former city employee.

MOTION: Council Member Africa Luna-Carrasco/Council Member Gloria Torres to appoint Council Member Jose Ponce to the Regional Council on Aging as presented. Motion passed unanimously.

The vote was as follows:

Mayor Gerardo Sanchez	Aye
Council Member Africa Luna-Carrasco	Aye
Council Member Jose Ponce	Aye
Council Member Matias Rosales	Aye
Council Member Gloria Torres	Aye

5.B. Discussion and possible action on any and all matters regarding EcoVerde EG-Mini Skid Odor Control System for East Mesa Lift Station. (Eulogio Vera, Director of Public Works)

Mr. Eulogio Vera, Director of Public Works, explained that East San Luis has been experiencing significant residential growth as well as some commercial and industrial construction. The existing and new developments' wastewater in that area, in addition to diverted flows from the Juan Sanchez Diversion Lift Station, enter the East San Luis Lift Station and generates the need for an odor control unit to minimize odor issues.

MOTION: Council Member Gloria Torres/Council Member Jose Ponce to waive formal purchasing procedures and approve the purchase of the EcoVerde System in the amount of \$78,610.00 as presented. Motion passed unanimously.

The vote was as follows:

Mayor Gerardo Sanchez	Aye
Council Member Africa Luna-Carrasco	Aye
Council Member Jose Ponce	Aye
Council Member Matias Rosales	Aye
Council Member Gloria Torres	Aye

5.C. Discussion and possible action on any and all matters regarding the approval and ratification of the Taylor Engineering project for the Cesar Chavez Boulevard formerly known as Juan Sanchez Boulevard Extension to Levee 6" Waterline. (Eulogio Vera, Director of Public Works)

Mr. Eulogio Vera, Director of Public Works, mentioned that the city requested quotes for the installation of approximately 575 linear feet of 6" water main per initial estimate based on the approximate location of existing water lines. The original quote came in well under the \$35,000.00, hence as allowed by the the purchasing code, it was procured with quotes. Taylor Engineering completed the project to meet the city's needs, which included some additional quantities and some unforeseen work.

Including the additional quantities and the change order work, the project total cost added up to \$35,752.60, exceeding the amount allowed by Section (D) and (E) of the city procurement code through the quote process.

MOTION: Council Member Africa Luna-Carrasco/Council Member Jose Ponce to waive formal purchasing procedures and approve ratification of payment to Taylor Engineering, P.L.L.C. in the amount of \$35,752.60. Motion passed unanimously.

The vote was as follows:

Mayor Gerardo Sanchez	Aye
Council Member Africa Luna-Carrasco	Aye
Council Member Jose Ponce	Aye
Council Member Matias Rosales	Aye
Council Member Gloria Torres	Aye

5.D. Discussion and possible action any and all matters regarding the purchase of two, five-row bleachers and two, ten-row bleachers for the Recreation Department. (Lizandro Galaviz, Director of Parks & Recreation)

Mr. Lizandro Galaviz, Director of Parks & Recreation, mentioned that the Recreation Department has been looking into the possibility of purchasing two(2), five-row portable bleachers and two (2), ten-row portable bleachers for the last couple of months. These bleachers would be used for many upcoming events in which the community will be seated to enjoy the yearly baseball exhibitions brought to the city, the Fourth of July celebration, the Founders Day celebration and many more events planned throughout the year. Currently, the bleachers used for these events are a bit worn out, and staff has gone above and beyond to look for bleachers that are trustworthy and comfortable for the community.

MOTION: Vice Mayor Jose Ponce/Council Member Africa Luna-Carrasco to waive formal purchase procedures and approve the purchase of two (2) bleachers in the amount of \$45,320.40 as presented. Motion passed unanimously.

The vote was as follows:

Mayor Gerardo Sanchez	Aye
Council Member Africa Luna-Carrasco	Aye
Council Member Jose Ponce	Aye
Council Member Matias Rosales	Aye
Council Member Gloria Torres	Aye

5.E. Presentation followed by discussion and possible directions to staff on any and all matters regarding a Special Event Liquor License Application for the 2020 Lechuga Fest to be held on Saturday, January 25, 2020. (Lizandro Galaviz, Director of Parks & Recreation Department)

Mr. Lizandro Galaviz, Director of Parks & Recreation, explained that the City of San Luis Parks and Recreation Department is proposing to partner with Jaizu Entertainment Promotions to present an event concert to bring the band "La Brissa" (Cumbia style music) to our community. Staff will be developing a contract with promoters that will be funding the entertainment, sound, stage and other requirements by Ms. Kay Macuil, City Attorney and Risk Management for this event. The city would provide the facility venue for the event (fields, Cultural Center and trash containers). This is an opportunity to provide the residents with a concert type event that brings popular groups and artists for a low cost to the area. The city would request the Special Event Liquor Permit, with 25% going to the city and 75% to Jaizu Entertainment Promotions. This would be a onetime trial basis, and depending on the turnout, staff would renegotiate the contract for future events. Staff would like to develop these types of events to make the City of San Luis a tourism destination point and an economic boost opportunity for our local businesses. Funds raised from this event would benefit the field renovation fund to continue to enhance Joe Orduño Park. Tickets will be \$15.00 pre-sale and \$20.00 at the gate.

Mayor Gerardo Sanchez said that it is an excellent idea, they are willing to take the risk, events like these have been successful at local communities and San Luis Rio Colorado, Sonora.

Mr. Jairo Vargas stated that they are focusing in San Luis, Arizona as this is a good opportunity for everyone.

Mr. Jesus Garcia said that they already began the promotion and are negotiating with the band, they paid the upfront money and taking the risk. They are just waiting and hoping that the City Council supports this event.

Mayor Gerardo Sanchez directed staff to proceed.

5.F. Discussion and possible action on any and all matters regarding Ordinance No. 393. An Ordinance of the Mayor and City Council of the City of San Luis, Arizona amending the City Code by amending Chapter 112, "Transportation Business Regulations" to provide for a border area and a system of issuance and regulation for border area vehicle permits to park at Taxi Stands or wait at Taxi Waiting Stands within said border area; amending the definition for Taxicab; renumbering certain sections within Chapter 112; repealing any conflicting provisions; providing for severability, and establishing an effective date. (Richard Jessup, Chief of Police, Angel Ramirez, Fire Chief and Eulogio Vera, Public Works Director)

Mr. Marco Santana, San Luis Police Department Lieutenant, explained that the main focus of this ordinance is to move the taxi stand from the actual north side to the south side due to the congestion of vehicle and pedestrian traffic in the border area of the port of entry. Staff is concerned for the safety of people traveling and walking through the area.

Mr. Angel Ramirez, Fire Chief, stated that this item has been discussed in depth at previous work sessions and reiterated on some of the points of public safety.

Both Mr. Santana and Mr. Ramirez particularized on the statistics of the calls received to the port of entry on a daily basis.

Mr. Eulogio Vera, Director of Public Works, added that elaborating on the additional funding, this change would have to occur regardless of this ordinance due to the redesign of the new port for vehicle exit. This change will reduce the vehicular/pedestrian conflicts significantly and should ease that intersection. This will promote the safety and welfare of the general public.

Mayor Gerardo Sanchez said that after the president signed the \$152.4 million for the renovation, many changes will happen for the next three (3) years. Where the taxi stand is at right now, that is where the changes will happen.

Mr. Jose A. Guzman, Director of Planning & Zoning, commented that an urban study was done by General Services Administration (GSA) and the State Department approximately two (2) years ago and this location was the recommended location to do the change of the taxi stand.

MOTION: Mayor Gerardo Sanchez/Council Member Africa Luna-Carrasco to adopt and approve Ordinance No. 393 by title only. Motion passed unanimously.

The vote was as follows:

Mayor Gerardo Sanchez	Aye
Council Member Africa Luna-Carrasco	Aye
Council Member Jose Ponce	Aye
Council Member Matias Rosales	Aye
Council Member Gloria Torres	Aye

Ms. Sonia Cornelio, City Clerk, read Ordinance No. 393 by title only.

MOTION: Council Member Africa Luna-Carrasco/Council Member Jose Ponce to adopt and approve Ordinance No. 393. Motion passed unanimously.

The vote was as follows:

Mayor Gerardo Sanchez	Aye
Council Member Africa Luna-Carrasco	Aye
Council Member Jose Ponce	Aye
Council Member Matias Rosales	Aye
Council Member Gloria Torres	Aye

6. SUMMARY OF CURRENT EVENTS

Mayor Gerardo Sanchez reported that many things have happened over the last week...one of them is the United States – Mexico – Canada Agreement (USMCA) was finally approved by Congress. Arizona is getting ready because this is something that both Arizona and Sonora have been waiting for as it will help the state and locally and it will promote the economy for both countries. Secondly, the House of Representatives, the Senate, and the President have signed the spending bill of \$152.4 million for the renovation of the port of entry; \$248 million was requested, but the City of San Luis did get \$152.4 million. No other port in the nation got funded but the San Luis Port of Entry as it is a priority. This is not a U.S. credit but Mexico's, the improvements need to be seen in Mexico as well and both countries need to work together; there will be a lot of construction for the next three (3) years. There will be work and opportunities for businesses. Other states wanted this money, the City of San Luis port of entry is very fortunate to have obtained this funding. He thanked the City Council for the support. With this, there is a stronger argument for Cesar Chavez Boulevard and Hwy 95, the city will need funding and will be knocking on Arizona Department of Transportation (ADOT) and the governor.

Council Member Matias Rosales thanked staff for the Christmas Light Parade and looks forward for the \$152.4 million for the port of entry and his understanding is that the this project was the only GSA project that got funded nationwide.

Council Member Africa Luna-Carrasco reported that she sat the Christmas Light Parade next to the announcing/judges booth and the comments from the public were very positive, the public enjoyed the parade.

7. CALL TO THE PUBLIC

Ms. Kay Macuil, City Attorney, stated that she appreciates the work that the City Council did for many years and the City Manager for bringing the federal funding for the Port of Entry. Also the CAFR is done, from the city's part, everything looks good. Thinking of the budget, she encouraged the City Council and City Manager to envision San Luis with the new port coming in.

Mr. Lizandro Galaviz, Director of Parks & Recreation, introduced Ms. Angelica Roldan, Assistant Director of Parks & Recreation.

8. ADJOURNMENT

MOTION: Council Member Africa Luna-Carrasco/Council Member Jose Ponce to adjourn the Special Council meeting at approximately 7:25 p.m. Motion passed unanimously.

The vote was as follows:

Mayor Gerardo Sanchez	Aye
Council Member Africa Luna-Carrasco	Aye
Council Member Jose Ponce	Aye
Council Member Matias Rosales	Aye

APPROVED:

Gerardo Sanchez, Mayor

ATTEST:

Sonia Cornelio, City Clerk

CERTIFICATION

I HEREBY CERTIFY THAT THE FOREGOING MINUTES ARE A TRUE AND CORRECT COPY OF THE MINUTES OF THE SPECIAL CITY COUNCIL MEETING FO THE CITY COUNCIL, SAN LUIS, ARIZONA HELD ON DECEMBER 23, 2019. I FURTHER CERTIFY THAT THE MEETING WAS DULLY CALLED AND HELD AND THAT A QUORUM WAS PRESENT.

Sonia Cornelio, City Clerk



AGENDA ITEM REVIEW FORM

Regular City Council Meeting

5. B.

Meeting Date: 01/08/2020

Summary

DISBURSEMENTS FROM DECEMBER 14, 2019 THROUGH DECEMBER 27, 2019.

Total Disbursements \$666,676.54

(Six Hundred Sixty-Six Thousand, Six Hundred Seventy-Six Dollars and Fifty-Four Cents)

Attachments

Disbursements



City of San Luis

Finance Department

COUNCIL MEETING JANUARY 8, 2020 Disbursement Reports from 12/14/2019 to 12/27/2019

<u>Bank Accounts</u>	<u>Check Date</u>	<u>Amount</u>	<u>Schedule</u>
Accounts Payable Check Account	12/19/2019	\$ 93,986.82	Schedule A
Payroll Check Account	12/23/2019	\$ 338,684.07	Schedule B
Accounts Payable Check Account	12/24/2019	\$ 234,005.65	Schedule C

Total Disbursements: \$ 666,676.54

Please contact Ms. Monica Castro prior to the meeting if additional information is needed.

Prepared by Angelica V. Castro: Angelica V Castro

Verified by Director of Finance: CCortés

For Council approval on: _____

Mayor: _____

Council: _____

RECEIVED
2019 DEC 30 P 1:18
CITY OF SAN LUIS
OFFICE OF THE CITY CLERK

Payment Register

From Payment Date: 12/16/2019 - To Payment Date: 12/19/2019

Number	Date	Status	Void Reason	Reconciled/ Voided Date	Source	Payee Name	Transaction Amount	Reconciled Amount	Difference
1BYPAYABLE - 1st BY Accounts Payable Totals									

Checks	Status	Count	Transaction Amount	Reconciled Amount
	Open	73	\$93,986.82	\$0.00
	Reconciled	0	\$0.00	\$0.00
	Voided	0	\$0.00	\$0.00
	Stopped	0	\$0.00	\$0.00
	Total	73	\$93,986.82	\$0.00

All	Status	Count	Transaction Amount	Reconciled Amount
	Open	73	\$93,986.82	\$0.00
	Reconciled	0	\$0.00	\$0.00
	Voided	0	\$0.00	\$0.00
	Stopped	0	\$0.00	\$0.00
	Total	73	\$93,986.82	\$0.00

Grand Totals:

Checks	Status	Count	Transaction Amount	Reconciled Amount
	Open	73	\$93,986.82	\$0.00
	Reconciled	0	\$0.00	\$0.00
	Voided	0	\$0.00	\$0.00
	Stopped	0	\$0.00	\$0.00
	Total	73	\$93,986.82	\$0.00

All	Status	Count	Transaction Amount	Reconciled Amount
	Open	73	\$93,986.82	\$0.00
	Reconciled	0	\$0.00	\$0.00
	Voided	0	\$0.00	\$0.00
	Stopped	0	\$0.00	\$0.00
	Total	73	\$93,986.82	\$0.00

Prepared By:
Maggie Dominguez
 Date: *Maggie D.*
C 12/19/19

Payment Register

From Payment Date: 12/16/2019 - To Payment Date: 12/19/2019

Number	Date	Status	Void Reason	Reconciled/ Voided Date	Source	Payee Name	Transaction Amount	Reconciled Amount	Difference
1BYPAYABLE - 1st BY Accounts Payable									
<u>Check</u>									
92444	12/17/2019	Open			Accounts Payable	GUZMAN, JOSE , A	\$76.00		
92445	12/17/2019	Open			Accounts Payable	PACHECO, ROMAN	\$76.00		
92446	12/17/2019	Open			Accounts Payable	PEREZ SANTOYO, JESUS, A	\$600.00		
92447	12/17/2019	Open			Accounts Payable	VILLAR, GLORIA	\$100.00		
92448	12/19/2019	Open			Accounts Payable	24 KARAT JEWELERS	\$136.62		
92449	12/19/2019	Open			Accounts Payable	CELAYA, MIGUEL	\$20.00		
92450	12/19/2019	Open			Accounts Payable	CORRALES FERNANDEZ, JUAN, F	\$180.00		
92451	12/19/2019	Open			Accounts Payable	HERNANDEZ, DIANA	\$798.20		
92452	12/19/2019	Open			Accounts Payable	LA PEQUENA	\$391.00		
92453	12/19/2019	Open			Accounts Payable	MOLINA, JOSE	\$98.57		
92454	12/19/2019	Open			Accounts Payable	NIEVES HEIDY QUINTERO	\$1,040.00		
92455	12/19/2019	Open			Accounts Payable	PANCHITA'S RESTAURANT	\$400.72		
92456	12/19/2019	Open			Accounts Payable	RODARTE, RODRIGO	\$309.60		
92457	12/19/2019	Open			Accounts Payable	RODRIGUEZ, DANIEL	\$1,500.00		
92458	12/19/2019	Open			Accounts Payable	ROMERO ALVAREZ, RAUL, A	\$20.00		
92459	12/19/2019	Open			Accounts Payable	SMART MANAGEMENT	\$700.00		
92460	12/19/2019	Open			Accounts Payable	4 IMPRINT	\$5,923.94		
92461	12/19/2019	Open			Accounts Payable	A & H ELECTRIC	\$280.00		
92462	12/19/2019	Open			Accounts Payable	ALSCO, INC	\$36.86		
92463	12/19/2019	Open			Accounts Payable	ANGEL'S TOWING SERVICE/AUTO SALES	\$225.00		
92464	12/19/2019	Open			Accounts Payable	ARIZONA STATE TREASURER	\$18,124.82		
92465	12/19/2019	Open			Accounts Payable	ARIZONA WESTERN COLLEGE	\$1,326.60		
92466	12/19/2019	Open			Accounts Payable	AUTOZONE STORES, INC	\$4,749.62		
92467	12/19/2019	Open			Accounts Payable	BLUE STREAK SIGNS, LLC	\$9.76		
92468	12/19/2019	Open			Accounts Payable	CORDOVA LAW, PLC	\$1,000.00		
92469	12/19/2019	Open			Accounts Payable	DESERT HEALTH CARE SERVICES, LLC	\$49.00		
92470	12/19/2019	Open			Accounts Payable	DESERT WATER	\$9.96		
92471	12/19/2019	Open			Accounts Payable	ESCALANTE, ALVARO	\$65.04		
92472	12/19/2019	Open			Accounts Payable	GAXIOLA, JESUS	\$146.54		
92473	12/19/2019	Open			Accounts Payable	HANSBERGER REGRIGERATION & ELECTRIC CO	\$1,803.37		
92474	12/19/2019	Open			Accounts Payable	HERNANDEZ, JERRY	\$400.00		
92475	12/19/2019	Open			Accounts Payable	HICKS, YANICK, N	\$499.00		
92476	12/19/2019	Open			Accounts Payable	INTERNATIONAL FESTIVALS & EVENTS ASSOC	\$610.00		
92477	12/19/2019	Open			Accounts Payable	JAMES DAVEY AND ASSOCIATES	\$1,960.00		
92478	12/19/2019	Open			Accounts Payable	JCG TECHNOLOGIES INC.	\$567.27		
92479	12/19/2019	Open			Accounts Payable	KONICA MINOLTA BUSINESS SOLUTIONS USA INC	\$86.13		
92480	12/19/2019	Open			Accounts Payable	LEGROS, BRIAN, SEAN	\$32.00		
92481	12/19/2019	Open			Accounts Payable	MCCURLEY, DOYLE	\$1,800.00		
92482	12/19/2019	Open			Accounts Payable	METRO FIRE EQUIPMENT INC	\$1,085.00		
92483	12/19/2019	Open			Accounts Payable	MGM INTERNET SOLUTIONS, INC	\$53.00		
92484	12/19/2019	Open			Accounts Payable	NICHOLS LOCK & KEY	\$105.00		
92485	12/19/2019	Open			Accounts Payable	NORWOOD EQUIPMENT INC.	\$1,298.40		
92486	12/19/2019	Open			Accounts Payable	O'REILLY AUTO PARTS	\$4,486.22		

Payment Register

From Payment Date: 12/16/2019 - To Payment Date: 12/19/2019

Number	Date	Status	Void Reason	Reconciled/ Voided Date	Source	Payee Name	Transaction Amount	Reconciled Amount	Difference
92487	12/19/2019	Open			Accounts Payable	ON TRACK OVERHEAD DOORS	\$125.00		
92488	12/19/2019	Open			Accounts Payable	PITNEY BOWES CREDIT CORP	\$382.99		
92489	12/19/2019	Open			Accounts Payable	POLAR ICE LLC	\$188.21		
92490	12/19/2019	Open			Accounts Payable	PUBLIC AGENCY TRAINING COUNCIL	\$1,500.00		
92491	12/19/2019	Open			Accounts Payable	PUBLIC SAFETY PERSONNEL RET SY	\$225.00		
92492	12/19/2019	Open			Accounts Payable	PURCELL TIRE CO.	\$691.31		
92493	12/19/2019	Open			Accounts Payable	QUINONEZ, FRANCISCO	\$75.00		
92494	12/19/2019	Open			Accounts Payable	RAMON MOSQUEDA	\$285.00		
92495	12/19/2019	Open			Accounts Payable	RDO EQUIPMENT CO.	\$428.46		
92496	12/19/2019	Open			Accounts Payable	REAL PURIFIED WATER LLC	\$41.62		
92497	12/19/2019	Open			Accounts Payable	REYES, NOE, A	\$150.00		
92498	12/19/2019	Open			Accounts Payable	SAFETY-KLEEN CORPORATION	\$150.00		
92499	12/19/2019	Open			Accounts Payable	SAHRA	\$20.00		
92500	12/19/2019	Open			Accounts Payable	SAN LUIS AIR CONDITIONING LLC	\$750.00		
92501	12/19/2019	Open			Accounts Payable	SHUCK DRILLING COMPANY LLC	\$20,822.49		
92502	12/19/2019	Open			Accounts Payable	SILVA, ELIZABETH	\$500.00		
92503	12/19/2019	Open			Accounts Payable	SOLORZANO, PEDRO	\$135.50		
92504	12/19/2019	Open			Accounts Payable	SPECTRUM BUSINESS	\$169.96		
92505	12/19/2019	Open			Accounts Payable	STANDARD PRINTING COMPANY, INC	\$1,842.07		
92506	12/19/2019	Open			Accounts Payable	THOMSON WEST PUBLISHING CO.	\$6,326.22		
92507	12/19/2019	Open			Accounts Payable	UNIVERSAL BACKGROUND SCREENING INC	\$789.25		
92508	12/19/2019	Open			Accounts Payable	URQUIJO, SALVADOR	\$97.73		
92509	12/19/2019	Open			Accounts Payable	US POST MASTER	\$2,773.26		
92510	12/19/2019	Open			Accounts Payable	WAL-MART RESTITUTION RECOVERY	\$27.24		
92511	12/19/2019	Open			Accounts Payable	WESTERN SUN SYSTEMS, INC	\$516.00		
92512	12/19/2019	Open			Accounts Payable	YUMA COUNTY ADULT DETENTION CENTER	\$3.30		
92513	12/19/2019	Open			Accounts Payable	YUMA COUNTY TREASURER	\$118.52		
92514	12/19/2019	Open			Accounts Payable	YUMA COUNTY WATER USERS	\$1,397.76		
92515	12/19/2019	Open			Accounts Payable	YUMA FARM & HOME SUPPLY INC.	\$7.64		
92516	12/19/2019	Open			Accounts Payable	YUMA WINNELSON CO.	\$268.05		
Type Check Totals:									
							73 Transactions	\$93,986.82	

Schedule B
Pay Day Register
 Pay Date Range 12/07/19 - 12/20/19
 Pay Batch 201926

PSPRS FIRE DC RATE - TIER 3	150.61	1,673.40
PSPRS FIRE DISABILITY RATE	25.27	1,673.40
PSPRS POLICE DB RATE - TIER	3,182.16	41,596.88
PSPRS POLICE DB RATE - TIER	3,055.90	26,230.86
PSPRS POLICE DB RATE - TIER 2	1,105.97	9,493.30
PSPRS POLICE DB RATE - TIER 3	1,879.96	18,913.18
STANDARD LIFE ADDTNL	969.63	.00
TRANSWESTERN MEXICAN	96.50	.00
U.S. MEX DENTAL - EE &	592.48	.00
U.S. MEX DENTAL - EE &	63.48	.00
UNITED WAY	14.00	.00
US & MEX DENTAL= FAMILY	607.66	.00
US & MEX HEALTH = C	6,241.67	.00
US & MEX HEALTH = FAMILY	4,812.15	.00
US & MEX HEALTH = SP	898.80	.00
VSP - VISION FAMILY	621.72	.00
Net	<u>\$338,684.07</u>	

Workers' Comp		Gross Base
ANIMAL CONTROL OFFICERS	61.79	2,746.18
ATTORNEY- ALL & CLERICAL-	68.68	31,220.55
AUTO SERVICE/ REPAIR	265.65	9,521.76
BUILDING- NOC OPER BY	1,073.00	29,640.67
BUS COMPANY AND DRIVERS	158.75	2,875.83
CLERICAL OFFICE/ LIBRARY/	258.90	107,873.58
Electrician	60.68	1,932.40
FIREFIGHTERS & DRIVERS	3,632.81	103,204.46
GARBAGE/ ASH/ REFUSE	281.48	4,503.60
MUNICIPAL/ TOWN/	83.18	4,752.92
PARKS- NOC ALL EMPLOYEES	608.97	19,643.47
POLICE OFFICERS	4,499.73	102,733.24
RECREATION- ALL EMPLOYEES/	195.56	14,273.92
SEWAGE DISPOSAL/ PLANT	685.05	19,914.41
Street or Road Construction	1,978.09	24,634.01
WATERWORKS OPERATIONS	619.49	17,852.54
Total	<u>\$14,531.81</u>	

Direct Deposits	Amount
1st Bank Yuma	23,442.22
ACADEMY BANK	1,715.61
Bank of America	1,534.08
BANKCORP BANK	250.00
BBVA COMPASS	913.35
Charles Sch	200.00
Chase Bank	152,082.25
CHASE BANK CA	1,242.05
chase centro	1,035.55
Federal Credit Union	36,696.67
FF CREDIT UNION	1,812.94
FIREFIGHTER FIRST CREDIT UNION	2,905.96
GREEN DOT BANK	1,060.39
National Bank	650.00
Navy Federal	18,485.39
NetSpend Corporation DD	120.00
NORTH ISLAND CREDIT UNION	648.10
Sunbank	1,668.71
USAA FEDERAL SAVING	1,552.80
WASHINGTON FEDERAL	1,072.09
Wells Fargo	63,083.62
Total	<u>\$312,171.78</u>

Prepared by:
Deborah Luna
 Date: _____

Approved by:
[Signature]

City of San Luis

Payment Register

From Payment Date: 12/23/2019 - To Payment Date: 12/24/2019

Number	Date	Status	Void Reason	Reconciled/ Voided Date	Source	Payee Name	Transaction Amount	Reconciled Amount	Difference
92555	12/24/2019	Open			Accounts Payable	SAN LUIS SPEAR POINT SOLAR I, LLC	\$39,336.94		
92556	12/24/2019	Open			Accounts Payable	SHALOM CONSTRUCTION LLC	\$30.27		
92557	12/24/2019	Open			Accounts Payable	SOUTH YUMA COUNTY LANDFILL	\$12,049.67		
92558	12/24/2019	Open			Accounts Payable	SOUTHWEST SANITATION SERVICES, LLC	\$517.24		
92559	12/24/2019	Open			Accounts Payable	SPECTRUM BUSINESS	\$4,571.91		
92560	12/24/2019	Open			Accounts Payable	TYLER TECHNOLOGIES, INC.	\$1,280.00		
92561	12/24/2019	Open			Accounts Payable	US BANK	\$2,200.00		
92562	12/24/2019	Open			Accounts Payable	VERIZON WIRELESS MESSAGING SVC	\$7,052.28		
92563	12/24/2019	Open			Accounts Payable	YUMA COUNTY PUBLIC WORKS	\$1,020.88		
92564	12/24/2019	Open			Accounts Payable	YUMA FARM & HOME SUPPLY INC.	\$474.15		
92565	12/24/2019	Open			Accounts Payable	YUMA OFFICE EQUIPMENT	\$3,438.29		
92566	12/24/2019	Open			Accounts Payable	YUMA REGIONAL MEDICAL CENTER	\$1,054.39		
92567	12/24/2019	Open			Accounts Payable	YUMA SUN INC	\$1,098.00		
92568	12/24/2019	Open			Accounts Payable	ZATARAIN, EDUARDO	\$150.00		
Type Check Totals:									
1BYPAYABLE - 1st BY Accounts Payable Totals								\$234,005.65	

Checks	Status	Count	Transaction Amount	Reconciled Amount
	Open	52	\$234,005.65	\$0.00
	Reconciled	0	\$0.00	\$0.00
	Voided	0	\$0.00	\$0.00
	Stopped	0	\$0.00	\$0.00
	Total	52	\$234,005.65	\$0.00

All	Status	Count	Transaction Amount	Reconciled Amount
	Open	52	\$234,005.65	\$0.00
	Reconciled	0	\$0.00	\$0.00
	Voided	0	\$0.00	\$0.00
	Stopped	0	\$0.00	\$0.00
	Total	52	\$234,005.65	\$0.00

Grand Totals:

Checks	Status	Count	Transaction Amount	Reconciled Amount
	Open	52	\$234,005.65	\$0.00
	Reconciled	0	\$0.00	\$0.00
	Voided	0	\$0.00	\$0.00
	Stopped	0	\$0.00	\$0.00
	Total	52	\$234,005.65	\$0.00

All	Status	Count	Transaction Amount	Reconciled Amount
	Open	52	\$234,005.65	\$0.00
	Reconciled	0	\$0.00	\$0.00
	Voided	0	\$0.00	\$0.00
	Stopped	0	\$0.00	\$0.00
	Total	52	\$234,005.65	\$0.00

Prepared By:
Maggie Dominguez
Date: 12/24/19

Payment Register

From Payment Date: 12/23/2019 - To Payment Date: 12/24/2019

Number	Date	Status	Void Reason	Reconciled/ Voided Date	Source	Payee Name	Transaction Amount	Reconciled Amount	Difference
1BYPAYABLE - 1st BY Accounts Payable									
<u>Check</u>									
92517	12/24/2019	Open			Accounts Payable	BALSINO, PETER, M	\$6.85		
92518	12/24/2019	Open			Accounts Payable	CALIFORNIA STATE DISBURSEMENT UNIT	\$92.30		
92519	12/24/2019	Open			Accounts Payable	CHARGO PA, GURSTEL	\$26.95		
92520	12/24/2019	Open			Accounts Payable	FOP/ALC	\$330.00		
92521	12/24/2019	Open			Accounts Payable	SAN LUIS POLICE OFFICERS ASSOC	\$390.00		
92522	12/24/2019	Open			Accounts Payable	STANDARD INSURANCE COMPANY	\$8,636.99		
92523	12/24/2019	Open			Accounts Payable	SUPPORT PAYMENT CLEARINGHOUSE	\$3,618.25		
92524	12/24/2019	Open			Accounts Payable	UNITED WAY OF YUMA COUNTY INC.	\$14.00		
92525	12/24/2019	Open			Accounts Payable	UNITED YUMA FIRE FIGHTERS ASSOC	\$90.50		
92526	12/24/2019	Open			Accounts Payable	UNITED YUMA FIRE FIGHTERS- IAFF	\$875.00		
92527	12/24/2019	Open			Accounts Payable	24 KARAT JEWELERS	\$3,077.65		
92528	12/24/2019	Open			Accounts Payable	AMBERLY'S PLACE	\$3,484.00		
92529	12/24/2019	Open			Accounts Payable	ARCTIC GLACIER USA INC	\$77.40		
92530	12/24/2019	Open			Accounts Payable	ARIZONA DEPT. OF ENVIRONMENTAL	\$65.00		
92531	12/24/2019	Open			Accounts Payable	ARIZONA MUNICIPAL RISK	\$127,640.00		
92532	12/24/2019	Open			Accounts Payable	AZ STATE PRISON COMPLEX - YUMA	\$71.20		
92533	12/24/2019	Open			Accounts Payable	AZ STATE PRISON COMPLEX - YUMA	\$219.00		
92534	12/24/2019	Open			Accounts Payable	B&H PHOTO & ELECTRONICS CORP.	\$109.95		
92535	12/24/2019	Open			Accounts Payable	BLUE TARP FINANCIAL, INC	\$1,187.28		
92536	12/24/2019	Open			Accounts Payable	CAMPA, JOAQUIN	\$18.29		
92537	12/24/2019	Open			Accounts Payable	CELAYA, PAOLA	\$168.00		
92538	12/24/2019	Open			Accounts Payable	CUEVAS, CHRISTIAN	\$75.00		
92539	12/24/2019	Open			Accounts Payable	DESERT WATER	\$8.30		
92540	12/24/2019	Open			Accounts Payable	FRANCO, MARTIN, A	\$48.00		
92541	12/24/2019	Open			Accounts Payable	GARCIA, JESUS	\$208.00		
92542	12/24/2019	Open			Accounts Payable	GARCIA, JOSE, R	\$32.53		
92543	12/24/2019	Open			Accounts Payable	GUST ROSENFELD P.L.C.	\$1,234.61		
92544	12/24/2019	Open			Accounts Payable	GUZMAN, JOSE, A	\$200.00		
92545	12/24/2019	Open			Accounts Payable	ISCA, INC	\$3,000.00		
92546	12/24/2019	Open			Accounts Payable	JAMES DAVEY AND ASSOCIATES	\$1,400.00		
92547	12/24/2019	Open			Accounts Payable	JAUREGUI, CESAR	\$150.00		
92548	12/24/2019	Open			Accounts Payable	LAGUNA, JOSE, LUZ	\$374.00		
92549	12/24/2019	Open			Accounts Payable	LESLIE'S POOL SUPPLY INC.	\$171.51		
92550	12/24/2019	Open			Accounts Payable	LOOMIS	\$1,578.28		
92551	12/24/2019	Open			Accounts Payable	MARKETING DESIGN AND PRINTING	\$487.29		
92552	12/24/2019	Open			Accounts Payable	RAMIREZ, FELIPE	\$84.00		
92553	12/24/2019	Open			Accounts Payable	RAMIREZ, TERESITA, D	\$252.00		
92554	12/24/2019	Open			Accounts Payable	RAMON MOSQUEDA	\$229.50		



AGENDA ITEM REVIEW FORM

Regular City Council Meeting

6. A.

Meeting Date: 01/08/2020

Department Head: Sonia Cornelio, City Clerk, City Clerk's Office

Submitted By: Sonia Cornelio, City Clerk, City Clerk's Office

Action Requested: Discussion Item - No Action to be Taken

ITEM:

Presentation followed by discussion on any and all matters regarding the development of a bicycling program and its benefits. **(Gene Dalbey, President Yuma Region Bicycle Coalition)**

SUMMARY:

There are many good reasons for bicycle commuting, recreational bicycling and creating a strong bike culture in general. Mr. Gene Dalby, President of the Yuma Region Bicycle Coalition, wants to present the development of a bicycling program and its benefits for the community.

RECOMMENDATION / SUGGESTED MOTION:

Discussion and possible directions to staff only, no action.

N/A

Fiscal Impact

IS THERE FISCAL IMPACT ASSOCIATED WITH THIS ITEM: N/A

CITY/STATE/FEDERAL FUNDS: N/A

TOTAL: N/A

BUDGETED AMOUNT: N/A

AVAILABLE AMOUNT TO TRANSFER: N/A

ACCT NAME & GL#/REMAINING BALANCE BEFORE PURCHASE: N/A

FISCAL IMPACT STATEMENT (IF THIS IS A BUDGET TRANSFER, YOU MUST ATTACH THE BUDGET ADJUSTMENT FORM):

There is no fiscal impact associated with this item at the moment.

Attachments

Yuma Region Bicycle Coalition

Yuma Region Bicycle Coalition

BETTER BICYCLE SAFETY

Let's make Yuma bicycle friendly and safe.



Somerton City Council likes bicycling

Improve the quality of life

YCSO likes bicycle safety

\$80,000,000 Bicycle Tourism to Arizona. Let's help Yuma get some of that Tourism Money

Bring more tourists to Yuma

YRMC Wellness likes bicycling

Year round bicycling

YMPO likes bicycling RTP 14-37

Yuma City Council likes bicycling 5/14/15

To new businesses, present Yuma with all of the benefits of bicycling.

Please contact:
Gene Dalbey 928 920 8482
eb_dalbey@yahoo.com

Yuma AZ 85366



Improve quality of life in Yuma

Best air at the lowest elevation

ADOT likes bicycling

Yuma County likes bicycling

San Luis community development likes bicycling

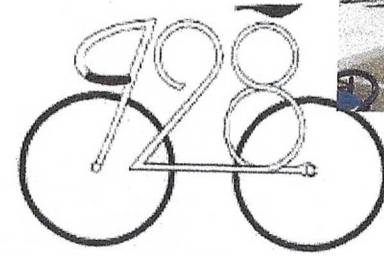

Yuma Region Bicycle Coalition

Yuma, AZ 85366





60+ Benefits (Advantages) of Bicycling

- Home
- About Us
- Economics
- Education
- Encouragement
- Engineering
- Environment
- Bibliography
- Essay Contest
- Ibike Tours
- Library
- Africa
- America
- Eurasia & Pacific
- Travel
- Contact Us
- Links
- Site Map



WE WOULD LOVE YOUR SUPPORT!

Our content is provided free as a public service!



IBF is 100% solar powered



▶ AdChoices

Cycle Price

Bike Bicycle

There are many, many good reasons for bicycle commuting, recreational bicycling and creating a strong bike culture in general. Hopefully a couple with resonate with everyone and motivate more bicycling.

1. On-going use of a bicycle has virtually NO carbon footprint.
2. You will be a leader in your community.
3. Bicycles increase mobility for those who don't have access to motor transport.
4. Bikes increase mobility for those who don't qualify to drive a car.
5. Bicycles increase mobility for those who can't afford motor transport.
6. Bikes increase mobility for those who don't want to drive motor vehicles.
7. Bicycles increase mobility for some people with arthritis, back problems and other mobility issues.
8. Bicycling can be faster than walking, transit or motor vehicles.
9. Bicycling is the most [energy efficient](#) form of transportation ever invented.
10. You get healthy exercise from bicycling.
11. Save travel money by biking. If the switch is from a car this includes purchase price, gas, tires, fluids, insurance, maintenance, washing, parking, etc.
12. Reduce stress by bicycling.
13. Biking is therapeutic for the mind and spirit -- is fun and can make you happy.
14. Cycling is therapeutic for the cardio-vascular system, live healthier.
15. Regular cycling provides better muscle tone, bone mass improvement, clearer skin
16. Regular bicycling helps with [personal weight management](#) -- new full-time bicycle commuters can expect to lose an average 13 pounds their first year of bicycle commuting if they maintain the same eating habits.
17. Bicycling is a great initial activity for people who are obese and help them on their way to a healthier life.
18. Regular cycling can lead to lower health care expenses -- save money for a nicer vacation.
19. Allows the rider to appreciate the more of the nuances of the natural and built environment around them.
20. Your commute will be the best part of your day instead of the worst part of your day.
21. The exercise increase your productivity at work
22. Cycling improves your self-esteem.
23. Primary school students will think you are "cool" or "hip" or "neat" or "rad" or whatever the current term is. In time even older people might come to appreciate your leadership.
24. Save on the membership to a health club, get your exercise bicycling to work, school, shopping, etc.
25. Bicycling is nearly a life-long activity.
26. Bicycling is a great full family and friends activity.
27. Cycling is low impact on the body.
28. Cycling is low impact on the environment
29. Bicycling in your neighborhood is a great way to meet your neighbors and build community.
30. Camaraderie of cyclists makes it a great way to meet a nice stranger with a similar interest.

31. Bicyclist can ignore the highway traffic jam reports.
32. Feel the satisfaction (liberation, freedom) of biking past a traffic jam in the bike lane.
33. Predictable commute time.
34. Easier parking.
35. Cheaper parking.
36. Leaving your car at home provide a parking space for someone less fortunate.
37. If you are lazy, your bicycle provides door-to-door transport (you don't have to walk across a vast parking lot).
38. Reduces the demand for new roads and paving the earth with asphalt and concrete.
39. Reduces the demand for parking lots and paving the earth.
40. Reduces energy consumption (see below).
41. Reduces air pollution -- bicyclist emit few poisonous gases. A four mile bicycle trip keeps about 15 pounds of pollutants out of the air we breathe.
42. Reduces greenhouse gas emissions.
43. Reduces water pollution -- bikes don't drip brake fluid, anti-freeze, transmission fluid, toxic dust, etc.
44. Reduces noise pollution -- even without a muffler bikes are quiet, creating a quieter community.
45. Reduces road wear -- even if cyclist feel like they have the weight of the world on their shoulders.
46. Reduces deforestation for planting of rubber plantations and bio-fuel crops, because bicycles use very little rubber and fuel/lubricants.
47. Reduces crime -- a huge amount of crime is associated with access to motor vehicles.
48. Reduces road kill and saves animals.
49. Demonstrates a concern for the future -- walk (ride) your talk.
50. Prevent and protest the sanctioned murder of innocent responsible citizens (homicide by motor-vehicle).
51. Bikes small profile reduces congestion.
52. Easy to vary your route by bicycle.
53. Increased bike use generates bike facilities which increase property values.
54. Bicycling gives you more fresh air than a sauna and you can still sweat and clean your pores
55. [Bike Commuting](#) is a license to dress weird and still feel smug.
56. Urban cycling keeps you humble.
57. Bicycling can be enjoyed in a wide variety of topography.
58. Cycling can be enjoyed in a wide variety of climates
59. Bicycles are a great means to see the world.
60. Bicycling is cool.
61. Biking Is Fun.

[IBF's Bicycle Bibliography / Reading List](#)



chrome

Yes, get Chrome now

[Home](#) | [About Us](#) | [Contact Us](#) | [Contributions](#) | [Economics](#) | [Education](#) | [Encouragement](#) | [Engineering](#) | [Environment](#) | [Bibliography](#) | [Essay Contest](#) | [Ibike Tours](#) | [Library](#) | [Links](#) | [Site Map](#) | [Search](#)

The International Bicycle Fund is an independent, non-profit organization. Its primary purpose is to promote bicycle transportation. Most IBF projects and activities fall into one of four categories: planning and engineering, safety education, economic development assistance and promoting international understanding. IBF's objective is to create a sustainable, people-friendly environment by creating opportunities of the highest practicable quality for bicycle transportation. IBF is funded by private donation. [Contributions](#) are always welcome and are U.S. tax-deductible to the extent allowed by law.



AGENDA ITEM REVIEW FORM

Regular City Council Meeting

6. B.

Meeting Date: 01/08/2020

Department Head: Lizandro Galaviz, Director of Parks & Recreation, Parks & Recreation Department

Submitted By: Crystal Fragozo, Administrative Assistant, Parks & Recreation Department

Action Requested: Motion
Public Hearing

ITEM:

Public hearing followed by discussion and possible action on any and all matters regarding the recommendation of a Special Event Liquor License Application to the Arizona Department of Liquor Licenses and Control to authorize the City of San Luis Parks & Recreation Department and Jaizu Entertainment Promotions to sell alcohol at the Lechuga Fest to be held on Saturday, January 25, 2020.
(Lizandro Galaviz, Director of Parks & Recreation Department)

- A. Open public hearing
 - 1. Presentation by staff and/or applicant
 - 2. Call to the public on this item
- B. Close public hearing
- C. Action on Special Event Liquor License Application to the Arizona Department of Liquor Licenses & Control

SUMMARY:

The City of San Luis Parks & Recreation Department and Jaizu Entertainment Promotions wishes to sell alcohol at the Lechuga Fest that will be held on Saturday, January 25, 2020, from 3:00 p.m to 2:00 a.m at the San Luis Joe Orduño Park. Proceeds of the beer sales will be split, 25% for the City of San Luis and 75% for Jaizu Entertainment Promotions.

The City of San Luis Parks and Recreation Department is proposing to partner with Jaizu Entertainment Promotions to present an event concert to bring the band “La Brissa” (Cumbia style music) to our community. With the assistance of the City Attorney and Risk Management, a contract will be developed in which promoters will be funding the entertainment, sound, stage and other requirements for this event. The city will provide the facility venue for the event (Fields, Cultural Center and trash containers). This is an opportunity to provide the residents a concert type event that brings popular groups and artists for a low cost to the area. This will be a onetime trial basis, and depending on the success of this event, a contract might be renegotiable for future events. Staff will like to develop these types of events to make the City of San Luis a tourism destination point and an economic boost opportunity for our local businesses.

Funds raised from this event will benefit the field renovation fund to continue to enhance Joe Orduño Park.

RECOMMENDATION / SUGGESTED MOTION:

A. I MOVE TO OPEN PUBLIC HEARING.

- 1. Presentation by staff and/or applicant.**
- 2. Call to the public on this item.**

B. I MOVE TO CLOSE PUBLIC HEARING.

C. I MOVE TO RECOMMEND APPROVAL TO THE ARIZONA DEPARTMENT OF LIQUOR LICENSES AND CONTROL THE APPLICATION FOR THE SPECIAL EVENT LIQUOR LICENSE OF THE CITY OF SAN LUIS PARKS & RECREATION DEPARTMENT.

N/A

Fiscal Impact

IS THERE FISCAL IMPACT ASSOCIATED WITH THIS ITEM:	NO
CITY/STATE/FEDERAL FUNDS:	N/A
TOTAL:	N/A
BUDGETED AMOUNT:	N/A
AVAILABLE AMOUNT TO TRANSFER:	N/A
ACCT NAME & GL#/REMAINING BALANCE BEFORE PURCHASE:	N/A
FISCAL IMPACT STATEMENT (IF THIS IS A BUDGET TRANSFER, YOU MUST ATTACH THE BUDGET ADJUSTMENT FORM):	

There is no associated fiscal impact with this item.

Attachments

Special Event Liquor License Application - Lechuga Fest 2020



Arizona Department of Liquor Licenses and Control
 800 W Washington 5th Floor
 Phoenix, AZ 85007-2934
 www.azliquor.gov
 (602) 542-5141

FOR DLLC USE ONLY

Event Date(s):
Event time start/end:
CSR:
License:

APPLICATION FOR SPECIAL EVENT LICENSE
 Fee= \$25.00 per day for 1-10 days (consecutive)
 Cash Checks or Money Orders Only

A service fee of \$25.00 will be charged for all dishonored checks (A.R.S § 44-6852)

IMPORTANT INFORMATION: This document must be fully completed or it will be returned.

The Department of Liquor Licenses and Control must receive this application ten (10) business days prior to the event. If the special event will be held at a location without a permanent liquor license or if the event will be on any portion of a location that is not covered by the existing liquor license, this application must be approved by the local government before submission to the Department of Liquor Licenses and Control (see Section 12).

SECTION 1 Name of Organization: City of San Luis, Arizona

Name of Licensed Contractor **only** (if any): _____

SECTION 2 Non-Profit/IRS Tax Exempt Number: 86-0376164

SECTION 3 Event Location: Joe Orduno Park

Event Address: 965 N. Park Ave.

SECTION 4 Applicant must be a member of the qualifying organization and authorized by an Officer, Director, or Chairperson of the Organization.

- Applicant: Galaviz Lizandro R. 05/05/1970
Last First Middle Date of Birth
- Applicant's mailing address: PO Box 1170 San Luis Arizona 85349
Street City State Zip
- Applicant's home/cell phone: (928) 919-8613 Applicant's business phone: (928) 341-8535
- Applicant's email address: lgalaviz@cityofsanluis.org

I, (Print Full Name) Lizandro R. Galaviz declare that I am the APPLICANT filing this application as listed above. I have read the application and the contents and all statements are true, correct and complete.

X _____
Signature Title/ Position Date Phone Number

The foregoing instrument was acknowledged before me this _____ Day _____ Month _____ Year
 State _____ County of _____

My Commission Expires on: _____ Date _____ Signature of Notary Public _____

SECTION 5 Regarding the Applicant's application for a special event permit, I hereby certify that the Organization meets the criteria in A.R.S. § 4-203.02(E) for the issuance of the permit as indicated by checking one of the boxes below.

- (1) The Applicant is a political party or a campaign committee supporting a candidate for public office. Please indicate the name of the candidate that the Applicant supports, the office that the candidate seeks, and the month and year that the applicant would first fill the office if successful.

Candidate: _____
Name Office Month/Year

- (2) The Applicant is a non-profit entity organized in Arizona, or pursuant to the laws of another state that is eligible for designation as a nonprofit entity under Section 501(C) of the internal revenue code of the United States. If the Applicant is applying under option (2) as a nonprofit entity, **please also INITIAL in the space provided next to all following statements to indicate that, to the best of the applicant's knowledge, they are true and correct.**

_____ The Applicant has received a determination letter from the Internal Revenue Service ("IRS") indicating that it is eligible for designation as a nonprofit entity under Section 501(C), eligibility or will be eligible on all days that the special event will occur, or has a pending application with the IRS for such treatment that has not been resolved but that will retroactively cover all days that the special event will occur. (Please provide a copy of either the IRS determination letter or the application [without attachments] with this application).

_____ The Applicant is not aware of any action by the IRS to revoke, suspend, or otherwise eliminate the Applicant's eligibility under 501(C), or if there is a pending application, the Applicant has not received any indication that the IRS will deny its application and has a good faith basis formed upon a reasonable inquiry into IRS regulations, guidelines, and forms that it is eligible under 501(C).

_____ The Applicant understands that if there is a change in circumstances after completing this form that may cause or has caused it to lose its eligibility under 501(C), whether before or after receiving an IRS determination letter, that it has an affirmative duty to notify the Department of Liquor, which may then take appropriate action with regard to the loss of eligibility.

To be completed only by an Officer, Director, or Chairperson of the organization.

I, (Print Full Name) <u>Lizandro Galaviz</u> declare that I am an Officer, Director, or Chairperson of the organization filing this application as listed above. I have read the application and the contents and all statements are true, correct and complete.			
X _____			
Signature	Title/ Position	Date	Phone Number
The foregoing instrument was acknowledged before me this _____			
	Day	Month	Year
State _____ County of _____			
My Commission Expires on: _____		_____	
Date	Signature of Notary Public		

SECTION 6 Will this event be held on a currently licensed premise and within the already approved premises? Yes No
 (If yes, Local Governing Body Signature **not** required)

Name of Business License Number Phone (Include Area Code)

SECTION 7 How is this special event going to conduct all dispensing, serving, and selling of spirituous liquors? Please read R-19-318 for explanation and check one of the following boxes.

- Place license in non-use
- Dispense and serve all spirituous liquors under retailer's license
- Dispense and serve all spirituous liquors under special event
- Split premise between special event and retail location

(IF USING RETAIL LICENSE, PLEASE SUBMIT A LETTER OF AGREEMENT FROM THE AGENT/OWNER OF THE LICENSED PREMISES TO SUSPEND OR RUN CONCURRENT WITH THE PERMANENT LICENSE DURING THE EVENT. IF THE SPECIAL EVENT IS ONLY USING A PORTION OF THE PREMISES, AGENT/OWNER WILL NEED TO SUSPEND THAT PORTION OF THE PREMISES.)

SECTION 8

What is the purpose of this event? On-site consumption Off-site (auction/wine/distilled spirits pull) Both

SECTION 9

1. Has the applicant been convicted of a felony, or had a liquor license revoked within the last five (5) years?
 Yes No (If yes, attach explanation.)
2. How many special event days have been issued to this organization during the calendar year? 0
(The number cannot exceed 10 days per year.)
3. Is the organization using the services of a promoter or other person to manage the sale or service of alcohol? Yes No
(If yes, must be a licensed contractor or licensee of series 6, 7, 11, or 12)

4. List all people and organizations who will receive the proceeds. Account for 100% of the proceeds. The organization applying must receive 25% of the gross revenues of the special event liquor sales. Attach an additional page if necessary.

Name City of San Luis Parks (Parks and Rec.) Percentage: 25 %
Address PO Box 1170 San Luis , Arizona 85349

Name Jaizu Entertainment Promotions Percentage: 75%
Address 103 East 24th Street Yuma Arizona 85364
Street City State Zip

Please read A.R.S. § 4-203.02 Special event license; rules and R19-1-205 Requirements for a Special Event License.

Note: ALL ALCOHOLIC BEVERAGE SALES MUST BE FOR CONSUMPTION AT THE EVENT SITE ONLY.

NO ALCOHOLIC BEVERAGES SHALL LEAVE A SPECIAL EVENT UNLESS THEY ARE IN AUCTION WINE OR DISTILLED SPIRITS PULL SEALED CONTAINERS OR THE SPECIAL EVENT LICENSE IS STACKED WITH WINE /CRAFT DISTILLERY FESTIVAL LICENSE.

5. What type of security and control measures will you take to prevent violations of liquor laws at this event?
(List type and number of police/security personnel and type of fencing or control barriers, if applicable.)
4 Number of Police 8 Number of Security Personnel Fencing Barriers
Explanation: Fencing and barricades will be placed around designated consumption areas. Entrance and exit will be posted.

Please contact the local governing board for additional application requirements and submission deadlines. Additional licensing fees may also be required before approval may be granted. For more information, please contact your local jurisdiction.

SECTION 12 Local Governing Body Approval Section.

Date Received: _____			
I, _____	_____	recommend	<input type="checkbox"/> APPROVAL <input type="checkbox"/> DISAPPROVAL
(Government Official)	(Title)		
On behalf of _____	_____	_____	_____
(City, Town, County)	Signature	Date	Phone

SECTION 13 For Department of Liquor Licenses and Control use only.

<input type="checkbox"/> APPROVAL <input type="checkbox"/> DISAPPROVAL BY: _____	DATE: ____/____/____
--	----------------------

A.R.S. § 41-1030. Invalidity of rules not made according to this chapter; prohibited agency action; prohibited acts by state employees; enforcement; notice

B. An agency shall not base a licensing decision in whole or in part on a licensing requirement or condition that is not specifically authorized by statute, rule or state tribal gaming compact. A general grant of authority in statute does not constitute a basis for imposing a licensing requirement or condition unless a rule is made pursuant to that general grant of authority that specifically authorizes the requirement or condition.

D. THIS SECTION MAY BE ENFORCED IN A PRIVATE CIVIL ACTION AND RELIEF MAY BE AWARDED AGAINST THE STATE. THE COURT MAY AWARD REASONABLE ATTORNEY FEES, DAMAGES AND ALL FEES ASSOCIATED WITH THE LICENSE APPLICATION TO A PARTY THAT PREVAILS IN AN ACTION AGAINST THE STATE FOR A VIOLATION OF THIS SECTION.

E. A STATE EMPLOYEE MAY NOT INTENTIONALLY OR KNOWINGLY VIOLATE THIS SECTION. A VIOLATION OF THIS SECTION IS CAUSE FOR DISCIPLINARY ACTION OR DISMISSAL PURSUANT TO THE AGENCY'S ADOPTED PERSONNEL POLICY.

F. THIS SECTION DOES NOT ABROGATE THE IMMUNITY PROVIDED BY SECTION 12-820.01 OR 12-820.02.

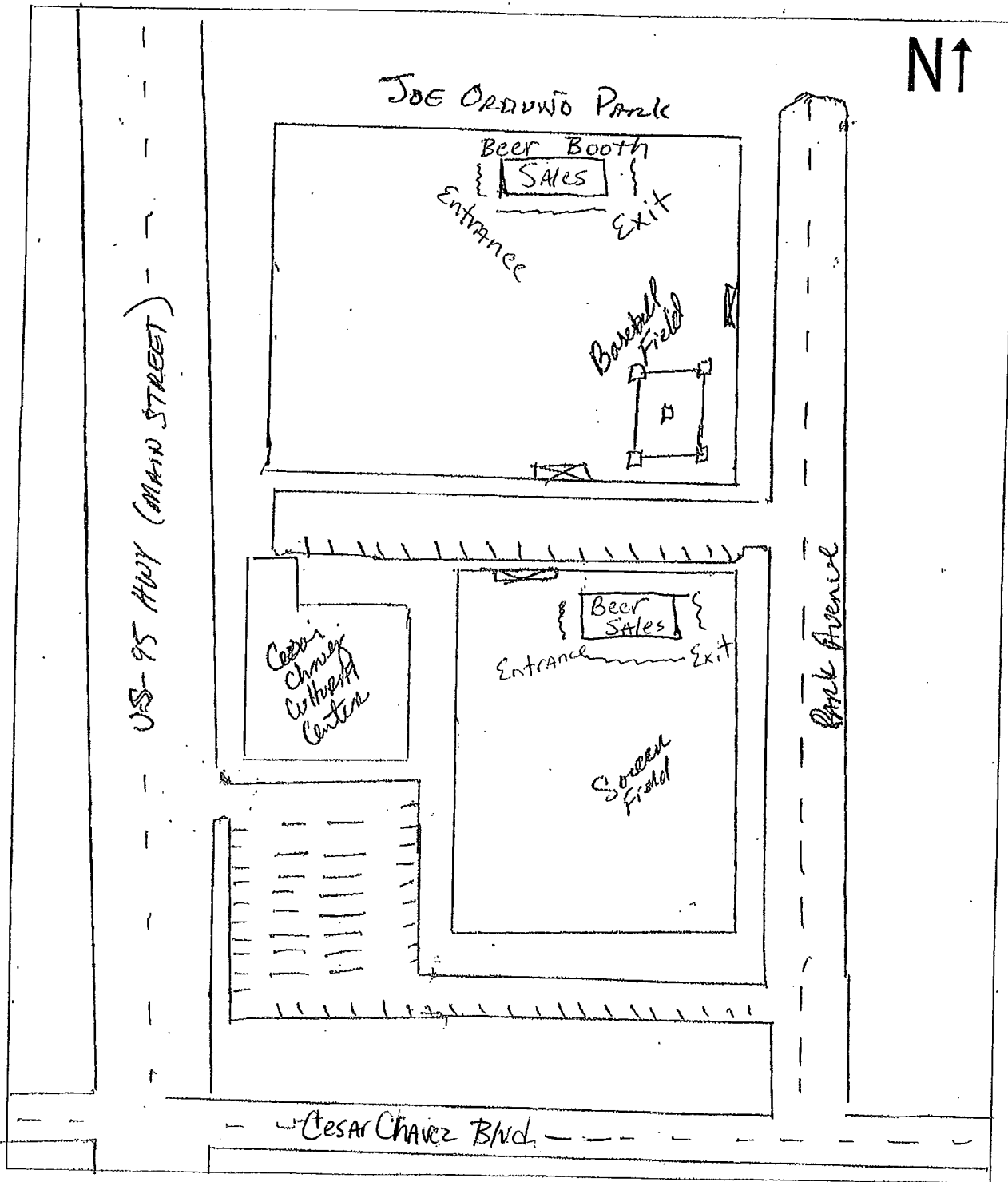

— Fencing



AGENDA ITEM REVIEW FORM

Regular City Council Meeting

6. C.

Meeting Date: 01/08/2020

Department Head: Richard Jessup, Chief of Police, Police Department

Submitted By: Michelle Boucher, Administrative Coordinator, Police Department

Action Requested: Motion

ITEM:

Discussion and possible action on any and all matters regarding authorization to purchase Mk 5 Model 895 Parking Meters with Apple Pay and Top Dome to replace out of service meters using Fiscal Year 2019-2020 Capital Projects budgeted funds. **(Richard Jessup, Chief of Police)**

SUMMARY:

The San Luis Police Department is seeking approval for the purchase of 75 new parking meters to replace current meters that are out of service.

The parking meters will come with all applicable equipment and software for payment processing. One training class for personnel will also be provided. The purchase will be made through IPS Group in the amount of \$49,689.21, which will include installation and shipping charges. Funds for the purchase were approved for use from Fiscal Year 2019-2020 Capital Projects.

RECOMMENDATION / SUGGESTED MOTION:

I MOVE TO APPROVE THE PURCHASE OF PARKING METERS IN THE AMOUNT OF \$49,689.21 AS PRESENTED.

N/A

Fiscal Impact

IS THERE FISCAL IMPACT ASSOCIATED WITH THIS ITEM:	Yes
CITY/STATE/FEDERAL FUNDS:	City
TOTAL:	\$49,689.21
BUDGETED AMOUNT:	\$51,030.00
AVAILABLE AMOUNT TO TRANSFER:	N/A
ACCT NAME & GL#/REMAINING BALANCE BEFORE PURCHASE:	100-999-90000 Capital Outlay \$51,030.00

FISCAL IMPACT STATEMENT (IF THIS IS A BUDGET TRANSFER, YOU MUST ATTACH THE BUDGET ADJUSTMENT FORM):

Funds to be used from Capital Outlay GL number 100-999-90000. Balance available before purchase \$51,030.00. Remaining funds after purchase will be \$1,340.79.

Attachments

Quote



7737 Kenamar Court,
San Diego, CA 92121

IPS Sales Quote

Date	Quote #
12/13/2019	IPS-2019-121371311

Name / Address

Ship To
San Luis Police Department 1030 E. Union St. P.O. Box 3720 San Luis, AZ 85349

Rep	P.O. No.	Terms	FOB
PS		Net 30	San Diego

Item	Description	Qty	Price	Total
Installation	Installation Services (2 Technician(s) - 2 Days)	1	\$3800.00	\$3800.00
895-504-A	Mk 5 Model 895 Meter with Apple Pay and Top Dome	75	\$540.00	\$40500.00
N/A	Coin Type : COINS	1	\$0.00	\$0.00
N/A	Coin Slots : Dollar	1	\$0.00	\$0.00
N/A	Card Decals : VISA,MASTER,AMERICAN EXPRESS	1	\$0.00	\$0.00
Notes-Freight	+ FREIGHT CHARGES	1	\$644.68	\$644.68

Subtotal	\$44,944.68
Sales Tax (10.71%)	\$4,744.53
Grand Total	\$49,689.21

TERMS AND CONDITIONS:

- Quote is stated in USD. Shipping and sales tax charges may apply.
- Orders will not be submitted until a Purchase Order has been issued or a signed copy of the quote is received by IPS Group, Inc. If your company uses a blanket purchase order, please write the number in the 'P.O. No.' box near the top of the quote.
- All requested information must be sent to the email address listed below or via mail. Notification will be sent once the order is submitted for processing.
- This quote expires 90 days after the date it was issued.
- Additional installation services required will be charged \$950/day per technician.
- Training and Commissioning will be \$1000 minimum on a new installation if applicable.

Signature _____

Phone #	Fax #	E-mail
858-568-7648	858-408-7839	support@ipsgroupinc.com



AGENDA ITEM REVIEW FORM

Regular City Council Meeting

6. D.

Meeting Date: 01/08/2020

Department Head: Richard Jessup, Chief of Police, Police Department

Submitted By: Michelle Boucher, Administrative Coordinator, Police Department

Action Requested: Motion
Order

ITEM:

Discussion and possible action on any and all matters regarding Order No. 2020-1. An order of the Mayor and City Council of San Luis, Arizona to authorize the San Luis Police Department to receive additional funding for equipment by approving Highway Safety Contract Number 2020-PTS-054 amendment number 2020-012 between the City Of San Luis, Arizona through the San Luis Police Department and the Arizona Governor's Office of Highway Safety. **(Richard Jessup, Chief of Police)**

SUMMARY:

The San Luis Police Department is seeking approval for the purchase of two (2) speed monitoring awareness radar trailer systems with (SMART) variable message sign and optional equipment as follows: SMART VMS Aluminum Wheel Upgrade, Traffic Data Recording System w/flashcard, SMART VMS Tamper Alarm, and VMS Anti-Corrosion upgrade; which will significantly aid in reducing accidents and fatalities, as well as increasing the community's awareness about the dangers of speeding and aggressive driving on Highway 95 and State Route 195. Both highways are heavy traffic areas. They are main travel routes for both ingress and egress for vehicular traffic from the San Luis Commercial U.S. Port of Entry and the San Luis Non-Commercial U.S. Port of Entry that registers about 9,219 non-commercial and commercial vehicles per day traveling onto both of these highways.

The funds for this purchase will be taken from grant funds awarded by the Arizona Governor's Office of Highway Safety Contract Number 2020-PTS-054. An amendment of this grant was approved by the Arizona Governor's Office of Highway Safety specifically to increase the number of SAM Trailers purchased from one to two.

RECOMMENDATION / SUGGESTED MOTION:

I MOVE TO APPROVE AND ADOPT ORDER NO. 2020-1, AND APPROVE THE PURCHASE OF TWO (2) NEW STALKER SAM TRAILERS AND ASSOCIATED EQUIPMENT.

N/A

Fiscal Impact

IS THERE FISCAL IMPACT ASSOCIATED WITH THIS ITEM:	Yes
CITY/STATE/FEDERAL FUNDS:	State
TOTAL:	\$17,474.66
BUDGETED AMOUNT:	\$611,710.00
AVAILABLE AMOUNT TO TRANSFER:	N/A

ACCT NAME & GL#/REMAINING BALANCE BEFORE PURCHASE: Capital Outlay GOHS
250-181-90100

FISCAL IMPACT STATEMENT (IF THIS IS A BUDGET TRANSFER, YOU MUST ATTACH THE BUDGET ADJUSTMENT FORM):

Internal transfer of grant funds will be processed. Initially we requested \$12,000 to purchase one trailer, but we then requested an additional \$5,474.66 to purchase one additional trailer for a total of \$17,474.66. Additional funds were granted per this amendment.

250-181-90100.168 Capital Project GOHS-STEP 2020-PTS-054- \$12,000.00

Add budget \$5474.66 to account 250-181-90100.168 GOHS-STEP 2020-PTS-054 Amended Budget \$17,474.66

Attachments

Order No. 2020-1

Amendment

Quote



Order

No. 2020-1

OFFICE OF THE
MAYOR
CITY OF SAN LUIS

AN ORDER OF THE MAYOR AND CITY COUNCIL OF THE CITY OF SAN LUIS, ARIZONA TO AUTHORIZE THE CITY OF SAN LUIS POLICE DEPARTMENT TO RECEIVE ADDITIONAL FUNDING FOR EQUIPMENT BY APPROVING HIGHWAY SAFETY CONTRACT 2020-PTS-054 AMENDMENT NUMBER 2020-012 BETWEEN THE CITY OF SAN LUIS, ARIZONA THROUGH THE SAN LUIS POLICE DEPARTMENT AND THE ARIZONA GOVERNOR'S OFFICE OF HIGHWAY SAFETY.

WHEREAS, the City of San Luis had previously approved Order number 2020-1;

IT IS ORDERED by the Mayor and Council of the City of San Luis, State of Arizona as follows:

Section 1: That the Highway Safety Contract titled STEP Enforcement 2020-PTS-054 Amendment Number 2020-012 and the purchase of additional equipment are approved.

Section 2: That the appropriate City officials are hereby authorized and directed to enter into said agreement on behalf of the city and take any and all actions as may be necessary to effectuate said agreement.

PASSED AND ADOPTED by the Mayor and Council of the City of San Luis, Arizona this 8th day of January 2020.

Gerardo Sanchez, Mayor

ATTEST:

APPROVED AS TO FORM:

Sonia Cornelio, City Clerk

Kay Marion Macuil, City Attorney



DOUGLAS A. DUCEY
GOVERNOR

ALBERTO GUTIER
DIRECTOR
GOVERNOR'S HIGHWAY SAFETY REPRESENTATIVE

DATE: December 4, 2019

TRANSMITTAL: Amendment Number: 2020-012
Effective Date: December 4, 2019
Revision Number: 001
Project Coordinator: Chris Held
Contract Number: 2020-PTS-054
Program Area: 402-PTS

TO: Chief Richard Jessup
San Luis Police Department
1030 Ease Union Street
San Luis, AZ 85349

FROM: Alberto Gutier, Director
Governor's Highway Safety Representative
Governor's Office of Highway Safety

NARRATIVE:

The purpose of this Amendment is to add funds to Capital Outlay for the purchase of a 2nd speed trailer to enhance speed enforcement throughout the City of San Luis.

There is a **\$5,474.66** increase in Federal funds because of this Amendment.

ESTIMATED COSTS:

	<u>From</u>	<u>To</u>
I. Personnel Services (includes overtime)	\$7,299.00	\$7,299.00
II. Employee Related Expenses (ERE 37.00%)	\$2,701.00	\$2,701.00
III. Professional and Outside Services	\$	\$
IV. Travel In-State	\$	\$
V. Travel Out-of-State	\$	\$
VI. Materials and Supplies	\$	\$
I. Capital Outlay Speed Trailers	\$12,000.00	\$17,474.66
TOTAL ESTIMATED COSTS	<u>\$22,000.00</u>	<u>\$27,474.66</u>

*Includes all applicable training, tax, freight, and advertising costs. The GOHS reserves the right to limit reimbursement of Employee Related Expenses from zero (0) to a maximum rate of 40 percent. This is the maximum ERE amount to be reimbursed. It is agreed and understood that the San Luis Police Department shall absorb any and all expenditures in excess of \$ 27,474.66.

AGREEMENT AND AUTHORIZATION TO PROCEED

by State Official responsible to the Governor for the administration of the State Highway Safety Agency.

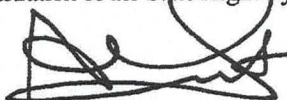

Alberto Gutier, Director
Governor's Highway Safety Representative
Governor's Office of Highway Safety

12-4-19

Date



applied concepts, inc.

855 E. Collins Blvd
Richardson, TX 75081
Phone: 972-398-3780
Fax: 972-398-3781

National Toll Free: 1-800- STALKER

Inside Sales Partner: Pam Schneidewind
972-801-4890

QUOTE
2034419

Page 1 of 1

Date: 11/25/19

Reg Sales Mgr: John Kestel
214-755-6325

Effective From : 11/25/2019

Valid Through: 01/31/2020

Lead Time: 32 working days

Bill To: San Luis Police Dept PO Box 3720 San Luis, AZ 85349-3720	Customer ID: P9485 Accounts Payable	Ship To: San Luis Police Dept 1030 East Union St San Luis, AZ 85349	<i>Deliver</i> Lieutenant Miguel Alvarez
---	---	---	---

Grp	Qty	Package	Description	Wrnty/Mo	Price	Ext Price
1	2	821-1000-00	Stalker SAM Trailer	24	\$7,350.00	\$14,700.00
	Ln	Qty	Part Number	Description	Price	Ext Price
	1	2	015-2532-59	[253259] SAM Trailer with Top Display		\$0.00
	2	2	200-1229-00	Traffic Stats Sensor, 2-Comm Ports, USB, Open Frame		\$0.00
	3	2	015-5345-00	[274714] SAM Trailer Solar Panel		\$0.00
	4	2	015-2328-62	[232862] Red LED Light Bar-SAM/SAM-R		\$0.00
	5	2	015-2354-40	[235440] Blue LED Light Bar-SAM/SAM-R		\$0.00
	7	2	200-1173-00	Stalker Traffic Analyst App, Thumb Drive, Manual		\$0.00
	8	2	011-0218-00	Stalker SAM/SAM-R Trailer User Manual		\$0.00
	9	2	006-0569-00	Certificate of Accuracy, Speed Sensor II		\$0.00
	10	2	060-1000-24	24-Month Warranty		\$0.00
Group Total						\$14,700.00

Product	\$14,700.00	Sub-Total:	\$14,700.00
Discount	\$0.00	Sales Tax 10.712%	\$1,574.66
Payment Terms: Net 30 days		Shipping & Handling:	\$1,200.00
		Total: USD	\$17,474.66

delivery, set up and training estimated to be
600.00 each trailer (each is 1/5 or 1/6 of truckload)
available spring 2020

001

This Quote or Purchase Order is subject in all respects to the Terms and Conditions sent along with the Quote.



AGENDA ITEM REVIEW FORM

Regular City Council Meeting

6. E.

Meeting Date: 01/08/2020

Department Head: Jose A. Guzman, Director of Planning & Zoning, Planning & Zoning Department

Submitted By: Jose A. Guzman, Director of Planning & Zoning, Planning & Zoning Department

Action Requested: Motion

ITEM:

Discussion and possible action on any and all matters regarding Subdivision Case No. 2019-0669F. A request by Riedel Holdings LLC, on behalf of Border Ranches LLC, property owner, for the final plat approval for Santa Cecilia No. 4 Subdivision. The property is located on the northeast corner of Aracely Street and 20th Avenue, Assessor's Parcel No. 227-10-013, San Luis, Arizona. **(Jose A. Guzman, Director of Planning and Zoning)**

A. Staff presentation

B. Action on Subdivision Case No. 2019-0669F

SUMMARY:

This is a request by Riedel Holdings LLC, on behalf of Border Ranches LLC, owner, for the approval of the final plat for Santa Cecilia No. 4 Subdivision. The subject property is located in the east mesa of the City of San Luis; east side of 20th Avenue between San Luis Lane and Aracely Street, Assessor's Parcel No. 227-10-013.

Bienestar 9A Phase 2 Subdivision is located to the west and zoned Medium Density Residential (R1-6). The east property is zoned as Medium-High Density Residential (R-2) and is undeveloped land. Future Santa Cecilia 3 Subdivision is under construction and will be located to the south and is zoned as Medium Density Residential (R1-6). Property to the north is part of Yuma County and is undeveloped land.

GENERAL PLAN:

This area is designated as Neighborhood in the City of San Luis 2020 General Plan. The activities proposed will be consistent with that designation (Chapter 2, Page 19-20). The Neighborhood land use designation allows all types of residential development.

ANALYSIS:

In 2007, the Arizona Legislature adopted legislation that required municipalities to certify that all new subdivisions had an assured 100-year water supply. On February 11, 2011, the City of San Luis was designated by the Arizona Department of Water Resources (ADWR) as having a 100-year adequate water supply. Consequently, individual subdivisions do not have to submit additional certification.

As an effort to alleviate the demand for bigger houses, the City Council approved Ordinance No. 347, an ordinance to set up the minimum lot size to 6,000 square feet. After this ordinance was adopted single detached dwellings are no longer allowed in Medium-High Density Residential (R-2) zoning district. This property was rezoned from Medium-High Density (R-2) to Medium Density Residential (R1-6) in order to allow the construction of the proposed subdivision (Rezoning Case No. 2019-0405).

The rezoning was approved with the following conditions:

1. That any development of the property, or portion thereof, and/or the approval of any subdivision plat, be conditioned upon payment to the city the sum of \$260.00 per acre, or any portion of an acre, as a proportionate contribution for a traffic signal at the intersection of County 24th Street and Avenue E. The city will initiate a regional circulation study in east San Luis within the next 12 months to establish the need for the traffic signals on Avenues F and E along County 24th Street. The study will provide an estimated time as to when the traffic signals will need to be installed.
2. A traffic study is required and the construction of any and all improvements as recommended by said study, including but not limited to, possible construction of street and/or signalization improvements along the County 23½ Street alignment. Such improvements to include the acquisition of any rights of way, if needed, so as to be able to develop and construct improvements as may be recommended.

The proposed subdivision consists of approximately 37 acres to be divided into 173 lots and 1 tract for a retention basin. The lots will range in size from 6,000 square feet to 12,000 square feet.

PLANNING AND ZONING COMMISSION MEETING:

This item was presented to the Planning and Zoning Commission at their regular meeting held on December 10, 2019. The Commission recommended approval subject to the applicant addressing the review comments on the letter dated November 21, 2019.

STAFF RECOMMENDATION:

The applicant provided the information and materials necessary for review of the final plat for Santa Cecilia No. 4 Subdivision.

A traffic study was prepared by Nicklaus Engineering, Inc., and is under review by city staff.

Staff recommends approval of Subdivision Case No. 2019-0669F subject to the following conditions:

1. The owner must pay to the city the sum of \$260.00 per acre, or any portion thereof, as a proportionate contribution for a traffic signal at the intersection of 24th Street and Avenue E.
2. Owner agrees to do any and all improvements as required by the traffic study prepared by Nicklaus Engineering, Inc. or any amendments to said study required by the city.

RECOMMENDATION / SUGGESTED MOTION:

I MOVE TO APPROVE THE FINAL PLAT FOR SANTA CECILIA NO. 4 SUBDIVISION WITH THE CONDITIONS AS RECOMMENDED AND PRESENTED BY STAFF.

N/A

Fiscal Impact

IS THERE FISCAL IMPACT ASSOCIATED WITH THIS ITEM: N/A
CITY/STATE/FEDERAL FUNDS: N/A
TOTAL: N/A
BUDGETED AMOUNT: N/A
AVAILABLE AMOUNT TO TRANSFER: N/A
ACCT NAME & GL#/REMAINING BALANCE BEFORE PURCHASE: N/A

FISCAL IMPACT STATEMENT (IF THIS IS A BUDGET TRANSFER, YOU MUST ATTACH THE BUDGET ADJUSTMENT FORM):

N/A

Attachments

Location Map
Aerial Picture
Final Plat

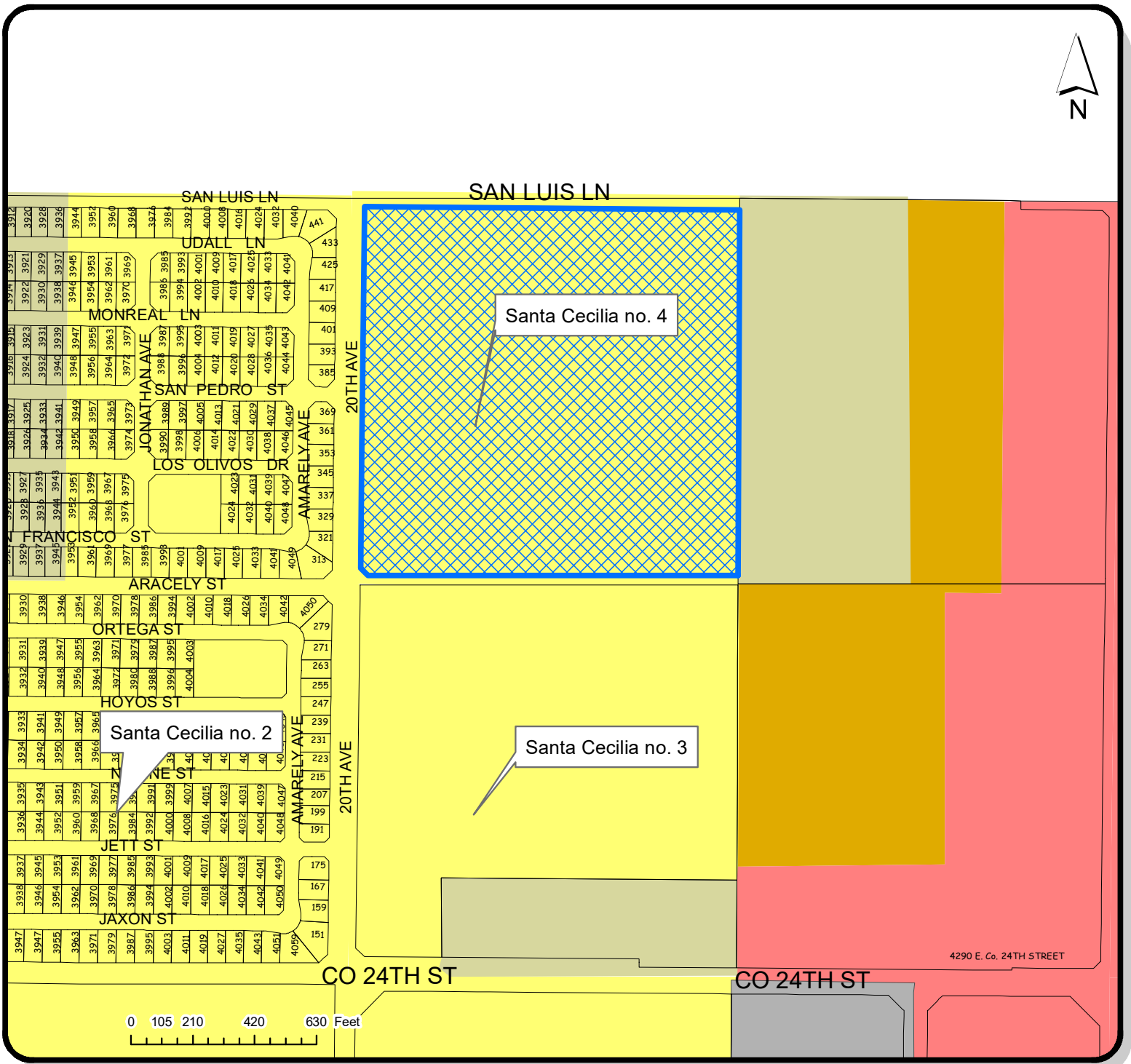

LOCATION OF SUBJECT PROPERTY

Location Map

SUBDIVISION

 SANTA CECILIA NO.4
Assessor's Parcel no. 22710013

Zoning
SINGLE RESIDENCE ZONING DISTRICTS
R-1-8
MULTIPLE RESIDENCE ZONING DISTRICTS
R-2
R-3
INDUSTRIAL ZONING DISTRICTS
LI
COMMERCIAL ZONING DISTRICTS
C-2

Date:
12/29/2019

PLANNING & ZONING



GIS

Prepared By:
ISAAC GUTIERREZ

APPROVED BY:
JOSE A. GUZMAN

Case No.
2019-0669F

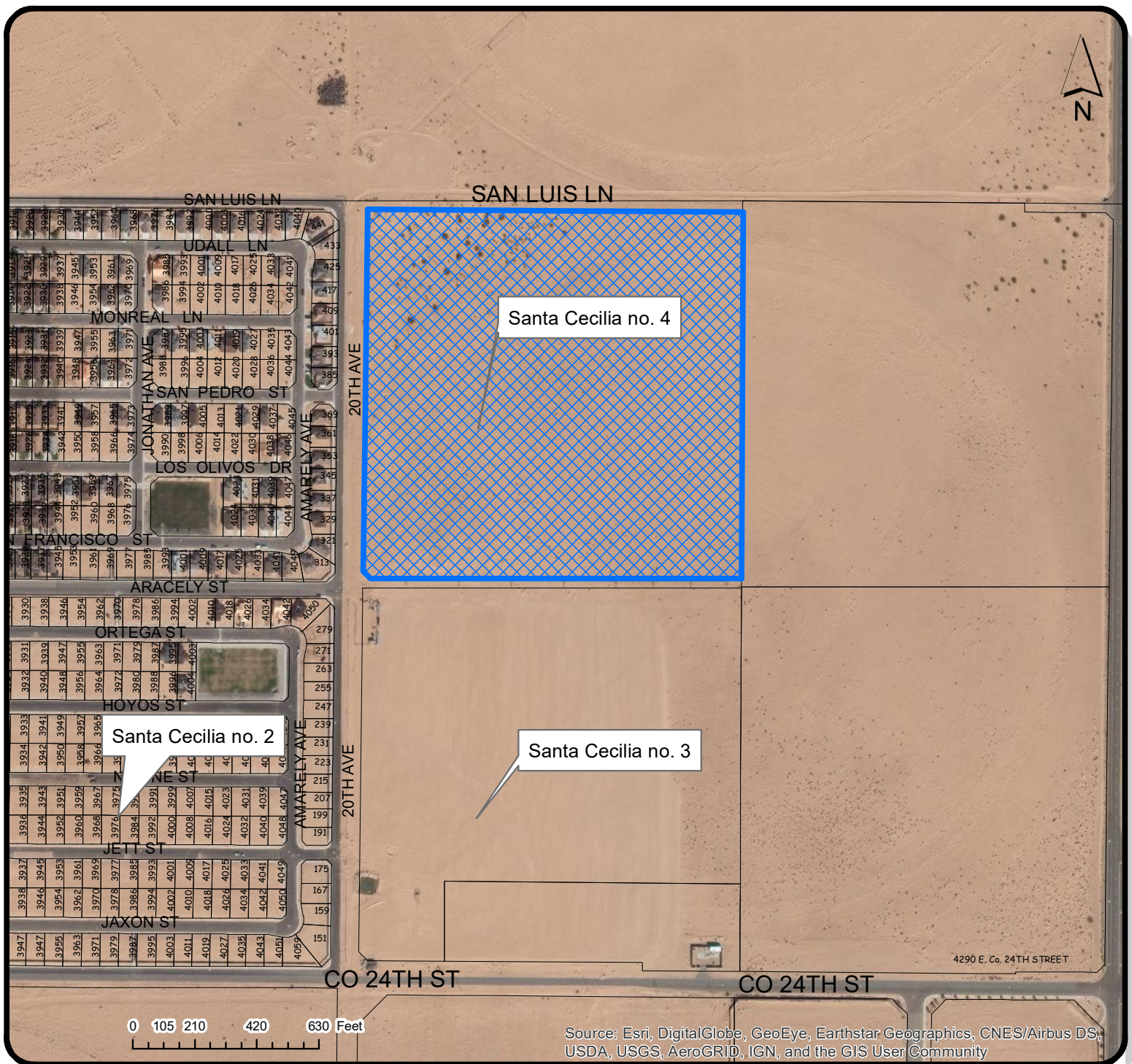

LOCATION OF SUBJECT PROPERTY

Location Map

SUBDIVISION

 SANTA CECILIA NO.4
Assessor's Parcel no. 22710013

Date:
12/29/2019

Checked By:
ROMAN PACHECO

PLANNING & ZONING



GIS

Prepared By:
ISAAC GUTIERREZ

APPROVED BY:
JOSE A. GUZMAN

Case No.
2019-0669F

SANTA CECILIA No. 4 SUBDIVISION

A SUBDIVISION OF LOT 3A OF SANTA CECILIA LOT TIE/LOT SPLIT AS RECORDED IN BOOK 30 OF PLATS,
 PAGE 98, YUMA COUNTY RECORDERS OFFICE, YUMA COUNTY, ARIZONA
 AND A PORTION OF THE NW1/4 SE1/4 OF SECTION 10, T11S, R24W, G.&S.R.B.&M., YUMA COUNTY, ARIZONA.
 DATE OF PREPARATION: AUGUST 2018 NUMBER OF LOTS: 173 ACREAGE: 36.79 ACRES

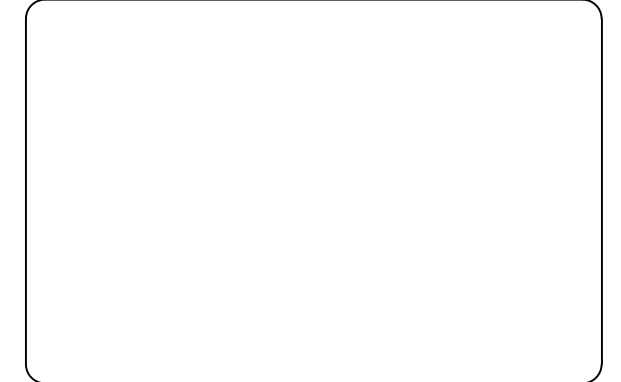

BOOK _____ OF PLATS,
 PAGE _____

FINAL PLAT

APPROVED

STATE OF ARIZONA)
 > SS
 CITY OF SAN LUIS)

THIS SUBDIVISION AS PLATTED HEREON HAS BEEN APPROVED BY THE
 MAYOR AND THE CITY COUNCIL OF THE CITY OF SAN LUIS, ARIZONA.

MAYOR _____ DATE _____

CITY MANAGER _____ DATE _____

DIRECTOR OF PLANNING AND ZONING DEPARTMENT _____ DATE _____

CITY ENGINEER _____ DATE _____

CITY PUBLIC WORKS DIRECTOR _____ DATE _____

BASIS OF BEARING

THE WEST LINE OF THE SW 1/4 OF SECTION 10, T11S, R24W,
 G.&S.R.B.&M., YUMA COUNTY, ARIZONA (BEING THE CENTERLINE OF
 AVENUE "F"), AS SHOWN ON BORDER RANGES SUBDIVISION, AS
 RECORDED IN BOOK 27 OF PLATS, PAGES 9&10, YUMA COUNTY
 RECORDERS OFFICE, YUMA COUNTY, ARIZONA,
 BEARING N00°02'42"W

RESTRICTIVE COVENANTS

HAVE BEEN RECORDED CONCURRENTLY AND ARE A PART OF THIS PLAT

SUBDIVIDER/OWNER

RIEDEL HOLDINGS, LLC
 1910 JUAN SANCHEZ BLVD
 P.O. BOX 1649
 SAN LUIS, AZ 85349
 (928) 627-8593

PREPARED BY:

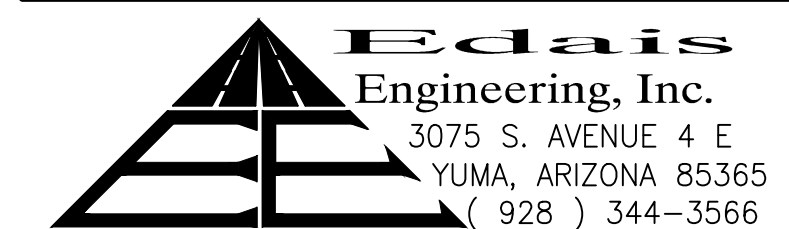

SURVEYOR'S CERTIFICATE

I HEREBY CERTIFY THAT I AM A LAND SURVEYOR LISTED ON THE ROSTER OF ACTIVE
 REGISTRANTS BY THE STATE BOARD OF TECHNICAL REGISTRATION OF ARIZONA AND
 THAT THIS MAP CONSISTING OF TWO(2) SHEET CORRECTLY REPRESENTS A SURVEY
 MADE UNDER MY SUPERVISION. THAT ALL MONUMENTS SHOWN HEREON ACTUALLY
 EXIST AND THEIR POSITIONS ARE CORRECTLY SHOWN.

JUAN N. LOMEI R.L.S. No. 22767

DEDICATION

KNOW ALL MEN BY THESE PRESENTS: THAT RIEDEL HOLDINGS, L.L.C., AN ARIZONA LIMITED LIABILITY COMPANY, AS OWNER HAS THIS THE ____ DAY OF _____ 2019,
 CAUSED A PORTION OF THE SW 1/4 OF SECTION 10, T11S, R24W, G. & S. R. B. & M. YUMA COUNTY, ARIZONA, AS PLATTED HEREON,
 TO BE SUBDIVIDED INTO LOTS, TRACT & STREETS UNDER THE NAME OF "SANTA CECILIA No. 4 SUBDIVISION" AND HEREBY DECLARES THAT THE ACCOMPANYING PLAT
 SETS FORTH THE LOCATION AND GIVES THE DIMENSIONS OF THE LOTS AND STREETS, CONSTITUTING SAID "SANTA CECILIA No. 4 SUBDIVISION" AND THAT EACH LOT
 SHALL BE KNOWN BY THE NUMBER, THE TRACT BY THE LETTER AND THE STREETS BY THE NAME GIVEN EACH RESPECTIVELY ON SAID PLAT;

AND THAT RIEDEL HOLDINGS, L.L.C., AS OWNER, HEREBY DEDICATES THE STREETS SHOWN HEREON TO THE CITY OF SAN LUIS FOR ITS USE AND BENEFIT, AND THAT
 THE EASEMENTS ARE DEDICATED FOR THE USES SHOWN AND DEFINED ON SAID PLAT AND AS SET FORTH IN THE DECLARATION OF RESERVATIONS, COVENANTS,
 CONDITIONS AND RESTRICTIONS RECORDED CONCURRENTLY HERewith. TRACT "A" IS DEDICATED TO THE CITY OF SAN LUIS FOR USE AS STORM WATER RETENTION
 BASIN AND COMPATIBLE RECREATIONAL USES. THE EASEMENTS ARE DEDICATED FOR THE PURPOSE SHOWN HEREON. A THREE FOOT NON-CONSTRUCTION AND NO
 OBSTRUCTION EASEMENT FROM THE FURTHER PROJECTION ON ANY SIDE OF ALL FIRE HYDRANTS; A TWELVE INCH NON-CONSTRUCTION AND NO OBSTRUCTION
 EASEMENT AROUND WATER METERS; AND 24 INCH NON-CONSTRUCTION AND NO OBSTRUCTION EASEMENT FOR STREET LIGHTS IS HEREBY GRANTED.

IN WITNESS WHEREOF: RIEDEL HOLDINGS, L.L.C., HAS CAUSED ITS CORPORATE NAME TO BE SIGNED AND ITS CORPORATE SEAL TO BE AFFIXED BY THE SIGNATURE
 OF NIEVES GARCIA RIEDEL, AS MEMBER, THEREUNTO DULY AUTHORIZED ON THIS THE ____ DAY OF _____ 2019.

BY: _____
 NIEVES GARCIA RIEDEL, MEMBER
 RIEDEL HOLDINGS, L.L.C.

ACKNOWLEDGMENT

STATE OF ARIZONA)
 > SS
 COUNTY OF YUMA)

ON THIS THE ____ DAY OF _____, 2019 BEFORE ME, THE UNDERSIGNED OFFICER
 PERSONALLY APPEARED, NIEVES GARCIA RIEDEL, WHO ACKNOWLEDGED HERSELF TO BE MEMBER OF
 RIEDEL HOLDINGS, L.L.C., AN ARIZONA LIMITED LIABILITY COMPANY, AND SHE AS SUCH OFFICER BEING
 AUTHORIZED TO DO SO, EXECUTED THE FOREGOING INSTRUMENT FOR THE PURPOSES THEREIN
 CONTAINED, BY SIGNING THE NAME OF THE LIMITED LIABILITY COMPANY BY HERSELF, AS SUCH
 OFFICER.

IN WITNESS WHEREOF, I HAVE SET MY HAND AND OFFICIAL SEAL.

BY: _____
 NOTARY PUBLIC

MY COMMISSION EXPIRES: _____

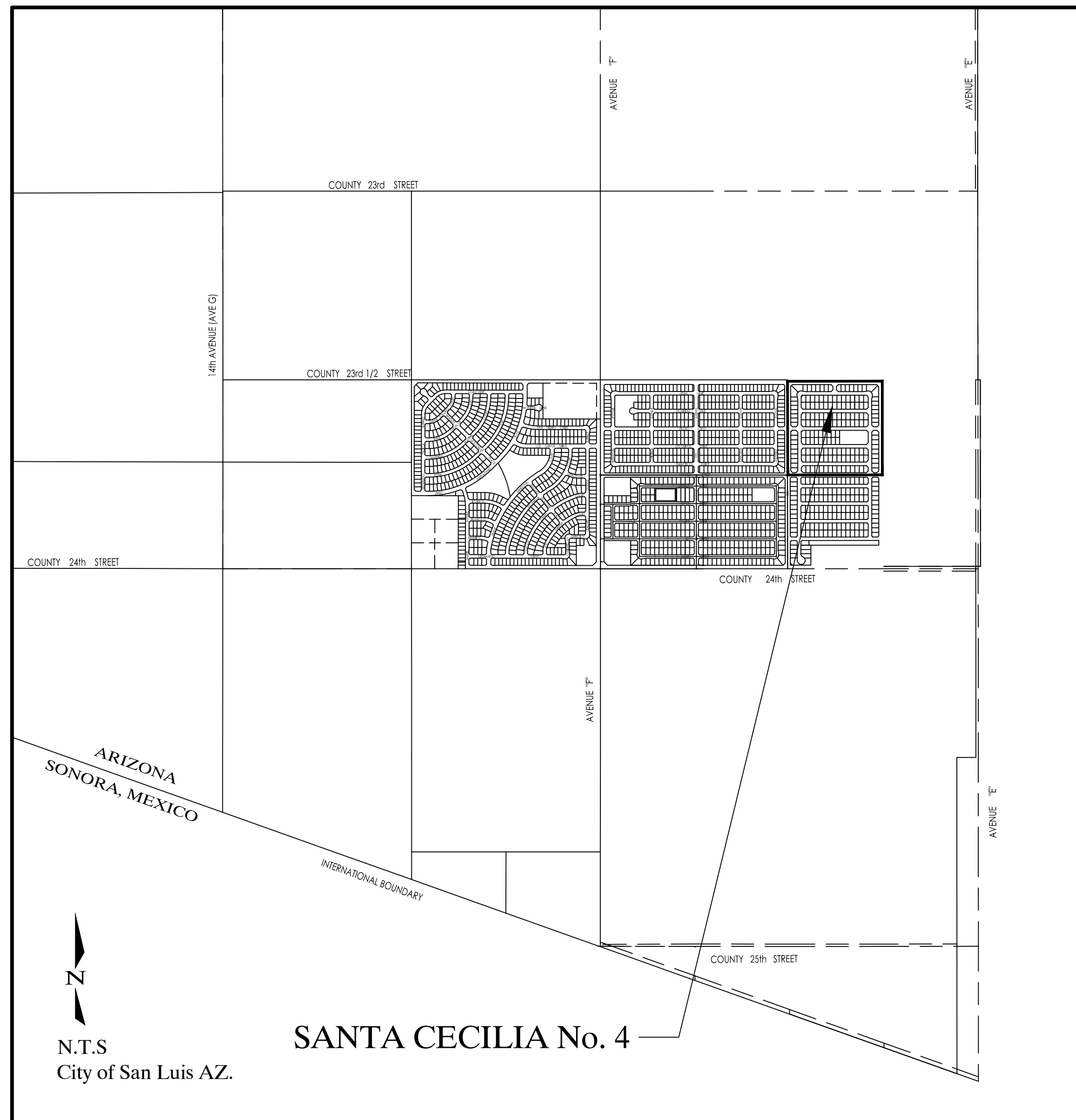

VICINITY MAP

N.T.S
 City of San Luis AZ.

SANTA CECILIA No. 4

SANTA CECILIA No. 4 SUBDIVISION

A SUBDIVISION OF LOT 3A OF SANTA CECILIA LOT TIE/LOT SPLIT AS RECORDED IN BOOK 30 OF PLATS, PAGE 98, YUMA COUNTY RECORDERS OFFICE, YUMA COUNTY, ARIZONA AND A PORTION OF THE NW1/4 SE1/4 OF SECTION 10, T11S, R24W, G.&S.R.B.&M., YUMA COUNTY, ARIZONA.

DATE OF PREPARATION: AUGUST 2018 NUMBER OF LOTS: 173 ACREAGE: 36.79 ACRES

FINAL PLAT

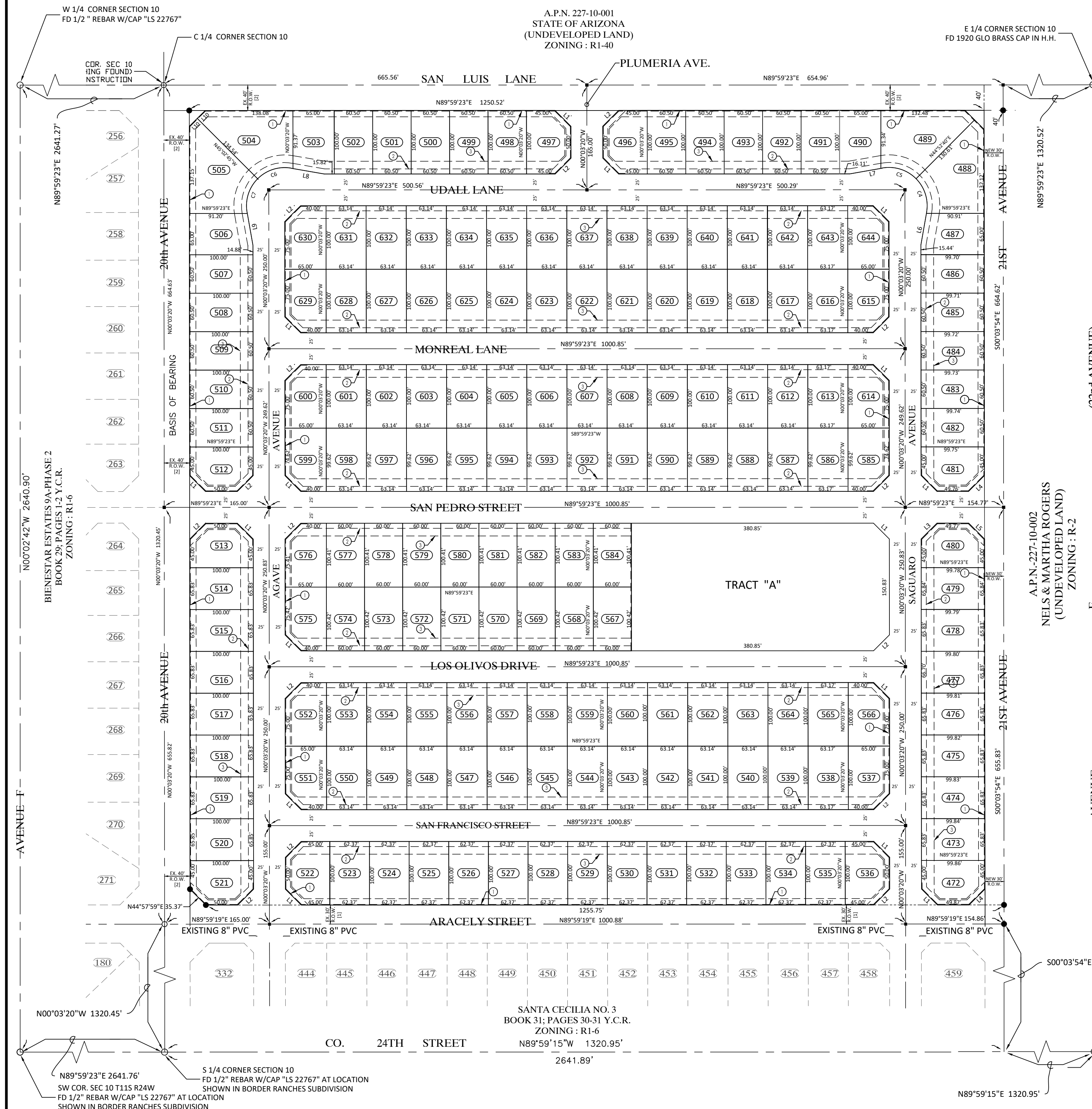
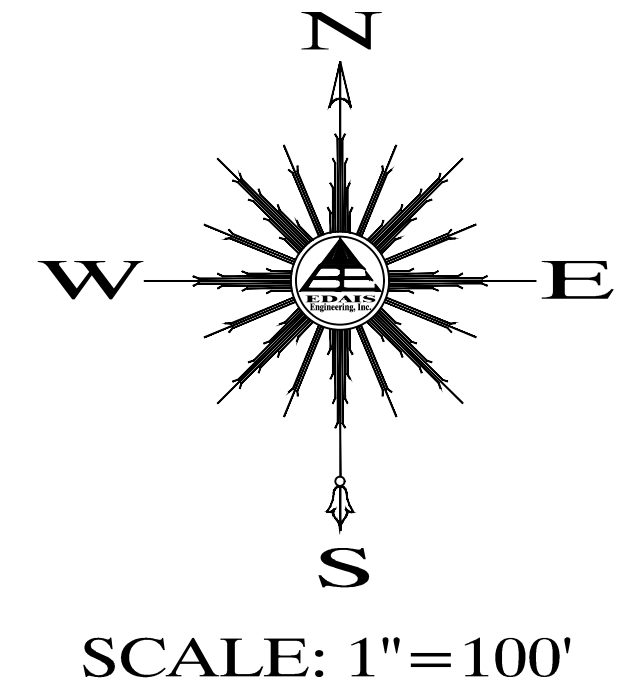

CURVE DATA

CURVE	DELTA	CHORD	DIRECTION	CHORD	TANGENT	RADIUS	LENGTH
C4	034°37'24"	N07°19'19"W	35.71'	18.70'	60.00'	36.26'	
C5	034°37'28"	N82°44'36"W	35.71'	18.70'	60.00'	36.26'	
C6	034°37'58"	S82°39'03"W	35.71'	18.70'	59.98'	36.26'	
C7	034°37'58"	S07°17'00"W	151.43'	18.70'	59.98'	36.26'	

LINE DATA

LINE	LENGTH	BEARING	LINE	LENGTH	BEARING
L1	35.37	N45°01'59"W	L6	52.06	S09°59'23"W
L2	35.34	N44°58'01"E	L7	52.06	S79°56'40"W
L3	35.37	N45°02'15"W	L8	52.62	S80°03'20"E
L4	35.34	N44°57'45"E	L9	52.62	S10°00'37"E
L5	35.37	S45°02'15"W	L10	17.68	S44°59'51"W

AREAS

LOT	AREA	LOT	AREA	LOT	AREA	LOT	AREA	LOT	AREA	LOT	AREA
472	6365.27 SF	497	6375.00 SF	522	6375.00 SF	547	6314.00 SF	572	6025.20 SF	597	6290.07 SF
473	6573.32 SF	498	6050.00 SF	523	6237.30 SF	548	6314.00 SF	573	6025.20 SF	598	6290.06 SF
474	6572.61 SF	499	6050.00 SF	524	6237.30 SF	549	6314.00 SF	574	6025.20 SF	599	6162.86 SF
475	6571.90 SF	500	6050.00 SF	525	6237.30 SF	550	6314.00 SF	575	6214.80 SF	600	6187.50 SF
476	6571.19 SF	501	6050.00 SF	526	6237.30 SF	551	6187.50 SF	576	6214.15 SF	601	6314.00 SF
477	6570.48 SF	502	6050.00 SF	527	6237.30 SF	552	6187.50 SF	577	6024.60 SF	602	6314.00 SF
478	6569.77 SF	503	6287.68 SF	528	6237.30 SF	553	6314.00 SF	578	6024.60 SF	603	6314.00 SF
479	6569.66 SF	504	10859.08 SF	529	6237.30 SF	554	6314.00 SF	579	6024.60 SF	604	6314.00 SF
480	6359.12 SF	505	10778.95 SF	530	6237.30 SF	555	6314.00 SF	580	6024.60 SF	605	6314.00 SF
481	6357.81 SF	506	6279.53 SF	531	6237.30 SF	556	6314.00 SF	581	6024.60 SF	606	6314.00 SF
482	6034.50 SF	507	6050.00 SF	532	6237.30 SF	557	6314.00 SF	582	6024.60 SF	607	6314.00 SF
483	6033.90 SF	508	6050.00 SF	533	6237.30 SF	558	6314.00 SF	583	6024.60 SF	608	6314.00 SF
484	6033.30 SF	509	6050.00 SF	534	6237.30 SF	559	6314.00 SF	584	6024.60 SF	609	6314.00 SF
485	6032.70 SF	510	6050.00 SF	535	6237.40 SF	560	6314.00 SF	585	6162.90 SF	610	6314.00 SF
486	6032.10 SF	511	6050.00 SF	536	6375.00 SF	561	6314.00 SF	586	6293.09 SF	611	6314.00 SF
487	6262.55 SF	512	6375.00 SF	537	6186.50 SF	562	6314.00 SF	587	6290.10 SF	612	6314.00 SF
488	10672.57 SF	513	6375.00 SF	538	6315.43 SF	563	6314.00 SF	588	6290.10 SF	613	6317.00 SF
489	10747.30 SF	514	6583.00 SF	539	6312.43 SF	564	6314.00 SF	589	6290.09 SF	614	6187.51 SF
490	6288.23 SF	515	6583.00 SF	540	6312.43 SF	565	6317.00 SF	590	6290.09 SF	615	6187.50 SF
491	6049.95 SF	516	6583.00 SF	541	6314.00 SF	566	6187.50 SF	591	6290.09 SF	616	6317.00 SF
492	6049.96 SF	517	6583.00 SF	542	6314.00 SF	567	6025.20 SF	592	6290.08 SF	617	6314.00 SF
493	6049.97 SF	518	6583.00 SF	543	6314.00 SF	568	6025.20 SF	593	6290.08 SF	618	6314.00 SF
494	6049.98 SF	519	6583.00 SF	544	6314.00 SF	569	6025.20 SF	594	6290.08 SF	619	6314.00 SF
495	6049.99 SF	520	6585.00 SF	545	6314.00 SF	570	6025.20 SF	595	6290.07 SF	620	6314.00 SF
496	6375.00 SF	521	6375.00 SF	546	6314.00 SF	571	6025.20 SF	596	6290.07 SF	621	6314.00 SF

LEGEND

- CENTERLINE
- RIGHT-OF-WAY (ROW) LINE
- NEW PROPERTY LINE
- EASEMENT (TYPE AS NOTED)
- BOUNDARY LINE
- NEW STREET MONUMENT AS PER YUMA COUNTY STD. DETAIL No. 4-080
- NEW SUBDIVISION BOUNDARY MONUMENT AS PER YUMA COUNTY STD. DETAIL No. 04-030
- EXISTING MONUMENT (TYPE AS SHOWN)
- (47) NEW LOT NUMBER
- (47) EXISTING LOT NUMBER
- A.P.N. ASSESSOR PARCEL NUMBER
- B.C. BRASS CAP
- H.H. HAND HOLE
- Y.C.R. YUMA COUNTY RECORDS
- G.&S.R.B.&M. GILA AND SALT RIVER BASE AND MERIDIAN
- [1] EXISTING R.O.W. PER SANTA CECILIA LOT TIE/LOT SPLIT AS RECORDED IN BOOK 30, PAGE 98, Y.C.R.
- [2] EXISTING R.O.W. PER BORDER RANGES SUBDIVISION AS RECORDED IN BOOK 27, PAGE 9, Y.C.R.

LOCATION MAP

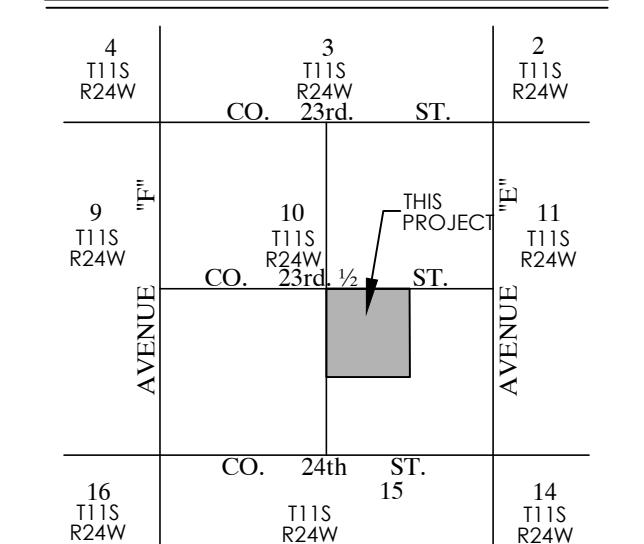

OWNER

RIEDEL HOLDINGS, LLC
 P.O. BOX 1649
 SAN LUIS, AZ 85349
 (928) 427-8553
 PARCEL NUMBER : 227-10-013
 CURRENT ZONING : R1-6

TRACT AREAS

TRACT	AREA
"A"	1.85 ACRES

SURVEYOR'S CERTIFICATE

I HEREBY CERTIFY THAT I AM A LAND SURVEYOR LISTED ON THE ROSTER OF ACTIVE REGISTRANTS BY THE STATE BOARD OF TECHNICAL REGISTRATION OF ARIZONA AND THAT THIS MAP CONSISTING OF TWO (2) SHEET CORRECTLY REPRESENTS A SURVEY MADE UNDER MY SUPERVISION, THAT ALL MONUMENTS SHOWN HEREON ACTUALLY EXIST AND THEIR POSITIONS ARE CORRECTLY SHOWN.

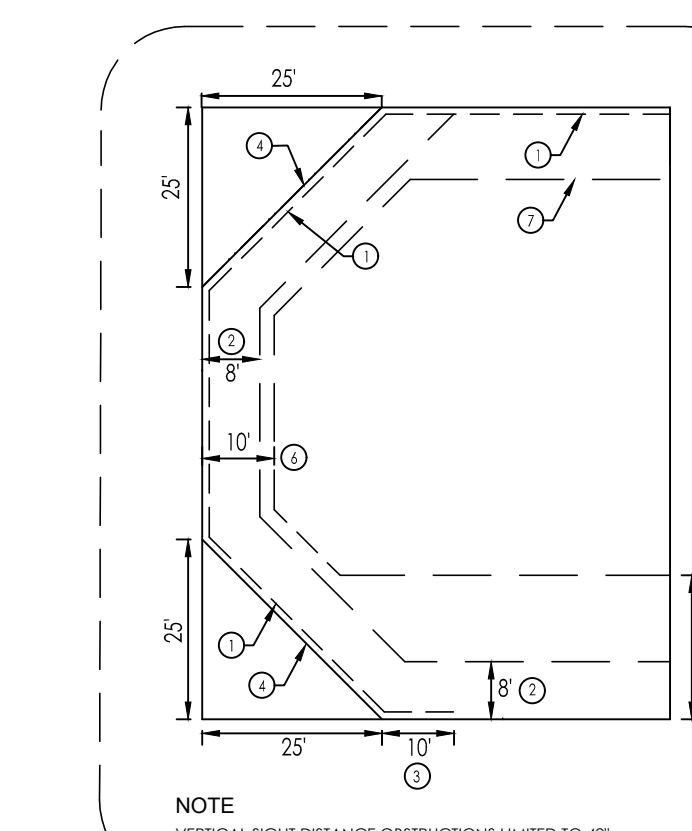

NOTE: VERTICAL SIGHT DISTANCE OBSTRUCTIONS LIMITED TO 4'

TYPICAL CORNER LOT DETAIL

KEYNOTES

- ① NEW 1' NON-ACCESS EASEMENT
- ② NEW 8' UTILITY & CATV EASEMENT
- ③ INDICATES 10' (1' NON-ACCESS EASEMENT)
- ④ 25' VISIBILITY TRIANGLE SEE TYPICAL CORNER LOT DETAIL.
- ⑤ NEW 20' FRONT YARD SETBACK LINE.
- ⑥ NEW 10' SIDE YARD SETBACK LINE.
- ⑦ NEW 10' REAR SETBACK LINE.

PREPARED BY:
Edais Engineering, Inc.
 3075 S. AVENUE 4 E
 YUMA, ARIZONA 85365
 (928) 344-3566

JUAN N. LOPEZ R.L.S. No. 22767



AGENDA ITEM REVIEW FORM

Regular City Council Meeting

6. F.

Meeting Date: 01/08/2020

Department Head: Jose A. Guzman, Director of Planning & Zoning, Planning & Zoning Department

Submitted By: Jose A. Guzman, Director of Planning & Zoning, Planning & Zoning Department

Action Requested: Motion
Resolution

ITEM:

Discussion and possible action on any and all matters regarding Resolution No. 2112. A resolution of the Mayor and City Council of the City of San Luis, Arizona, creating a Street Lighting Improvement District and declaring its intention to purchase electricity, and maintain poles, luminaries, and underground conduit, together with a charge for the use of lighting facilities, for lighting public streets within the area described as Santa Cecilia No. 4 Subdivision, San Luis, Arizona. **(Jose A. Guzman, Director of Planning & Zoning)**

SUMMARY:

As a requirement of the City of San Luis Subdivision Regulations, a Street Lighting Improvement District is required for new subdivisions. The city has received a petition to form a Street Lighting Improvement District for Santa Cecilia No. 4 Subdivision. This is the resolution of intention to create Santa Cecilia No. 4 Street Lighting Improvement District.

RECOMMENDATION / SUGGESTED MOTION:

I MOVE TO APPROVE AND ADOPT RESOLUTION NO. 2112.

N/A

Fiscal Impact

IS THERE FISCAL IMPACT ASSOCIATED WITH THIS ITEM: N/A

CITY/STATE/FEDERAL FUNDS: N/A

TOTAL: N/A

BUDGETED AMOUNT: N/A

AVAILABLE AMOUNT TO TRANSFER: N/A

ACCT NAME & GL#/REMAINING BALANCE BEFORE PURCHASE: N/A

FISCAL IMPACT STATEMENT (IF THIS IS A BUDGET TRANSFER, YOU MUST ATTACH THE BUDGET ADJUSTMENT FORM):

N/A

Attachments

Resolution No. 2112



Resolution

OFFICE OF THE
MAYOR
CITY OF SAN LUIS

No. 2112

A RESOLUTION OF THE MAYOR AND CITY COUNCIL OF THE CITY OF SAN LUIS, ARIZONA, CREATING A STREET LIGHTING IMPROVEMENT DISTRICT AND DECLARING ITS INTENTION TO PURCHASE ELECTRICITY, AND MAINTAIN POLES, LUMINARIES, AND UNDERGROUND CONDUIT, TOGETHER WITH A CHARGE FOR USE OF LIGHTING FACILITIES, FOR LIGHTING PUBLIC STREETS WITHIN THE AREA DESCRIBED AS SANTA CECILIA NO. 4 SUBDIVISION, SAN LUIS, ARIZONA.

WHEREAS, a petition for the street lighting improvement district has been presented by all of the real property owners of record for the real property described as Santa Cecilia No. 4 Subdivision, San Luis, Arizona.

NOW, THEREFORE, BE IT RESOLVED, by the Mayor and Council of the City of San Luis, Arizona, as follows:

Section 1: The City of San Luis hereby creates a street lighting improvement district to be tentatively known as Santa Cecilia No. 4 Street Lighting Improvement District for the area described as Santa Cecilia No. 4 Subdivision, San Luis, Arizona, and as further shown on Exhibit "A" attached hereto.

Section 2: That the public interest and convenience require, and it is the intention of the governing body of the City of San Luis to order the purchase of electricity which includes a charge for the maintenance and use of the lighting facilities. That the maintenance and purchase of electricity is of more than local or ordinary public benefit, and the cost is hereby made chargeable upon the District, and the District benefited by said streetlights is legally described as set forth in Section 1 hereinabove.

Section 3: That the cost of the electricity shall be the established rate of Arizona Public Service for street lighting service.

Section 4: That the lighting of the streets in the area described shall be in accordance with the lighting location plan hereby approved and adopted by the Council of the City of San Luis, Arizona, and on file in the office of the City Engineer, tentatively known as Santa Cecilia No. 4 Street Lighting Improvement District.

Section 5: In no event will the City of San Luis or any officer thereof be liable for any portion of the cost of supplying electricity to said Improvement District, no

assessment for district purposes against the property within such district exceeds the maximum contained in A.R.S. § 48-616.D, in which event the City of San Luis shall be liable for the cost of supplying electricity in excess of said statutory maximums.

Section 6: The City Council shall make an annual statement of the expenses relative to the District which shall be provided for by the levy and collection of the ad valorem taxes of the assessed value of all property, real and personal, in the District as provided in Title 48 of the Arizona Revised Statutes, which taxes shall be collected in the amount shown by the statement adopted by the City Council.

PASSED AND ADOPTED by the Mayor and City Council of the City of San Luis, Arizona, this _____ day of _____, 2020.

Gerardo Sanchez, Mayor

ATTEST:

APPROVED AS TO FORM:

Sonia Cornelio, City Clerk

Kay Marion Macuil, City Attorney

**PETITION, WAIVER AND CONSENT TO FORMATION
OF A STREET LIGHTING IMPROVEMENT DISTRICT
BY THE CITY OF SAN LUIS NEW SUBDIVISION, SANTA CECILIA NO. 4
(OWNER: RIEDEL HOLDINGS, LLC)**

**To: Honorable Mayor and City Council
 City of San Luis, Arizona**

Pursuant to Arizona Revised Statutes, Section 48-571 to 48-617, as amended, and specifically A.R.S. §48-572(A)(7), §48-616 and §48-617 the undersigned property owner respectfully petitions the City Council of the City of San Luis, Arizona ("City Council") to order the formation of Street Lighting Improvement District ("District") under Arizona Revised Statutes, Title 48 Chapter 4, Article 2. In support of this petition, the undersigned agree to waive certain rights under the Arizona Improvement District Law and to consent to the formation and completion of the District.

1. Area of District. The proposed district is described by a map and by a legal description of "Exhibit A" which is attached hereto and incorporated herein by reference. The proposed District consists of approximately 36.79 acres and is entirely within the corporate boundaries of the City of San Luis.
2. Ownership. The undersigned (is) (are) the sole owner(s) of the real property within the proposed District (the "Petitioner(s)") including any required public dedications of property.
3. Purpose. The District is proposed to be formed for the purpose of the installation of light poles and luminaries together with purchasing the electricity for lighting of public streets within Santa Cecilia No. 4 Subdivision.
4. Public Convenience and Necessity. The necessity for the proposed District is for the installation of light poles and luminaries with purchasing the electricity for lighting public streets within the proposed District by the levying of special assessments in the proposed District.
5. Wavier and Consent. The Petitioners with full knowledge of their rights being waived hereunder, hereby expressly waive all of the following:
 - (a) Any and all irregularities, illegalities or deficiencies which may exist in the acts or proceedings resulting in the adoption of the Resolution of Intention and the Resolution Ordering the Work relating to the District;
 - (b) Any necessity for publication and posting of the Resolution of Intention and the Notice of Proposed Improvements;
 - (c) All protest rights, whatsoever under A.R.S. §48-579 (A) and (B) as amended, which provide for protests against the work; and

- (d) All rights to petition to dissolve the district pursuant to A.R.S. §48-574(N);
- (e) All objections to the filing of and adoption by the City of the plans and specifications, the Engineer's estimate and the Assessment Diagram, all of which provide for the completion of the District.

Further the improvements described above are of more than local or ordinary public benefit.

In Witness whereof the parties have executed this Petition and waiver agreement as of the 7 day of JANUARY 2020.

<u>PROPERTY OWNER</u> <u>NAME, ADDRESS AND</u> <u>SIGNATURE</u>	<u>DATE</u>	<u>PROPERTY</u> <u>(Tax Parcel Nos.)</u>
RIEDEL HOLDINGS, LLC P.O BOX 1649 SAN LUIS, AZ 85349 By: <u><i>Nieves Riedel</i></u> Nieves Riedel, Owner		<u>APN 227-10-013</u>

STATE OF ARIZONA)
)ss.
 County of Yuma)

The foregoing acknowledged before me this 07 day of January 2020 by Nieves Riedel, Owner of Riedel Holdings, LLC, an Arizona Corporation, on behalf of said corporation.

My Commission Expires

Nydia E. Mendenhall
 Notary Public

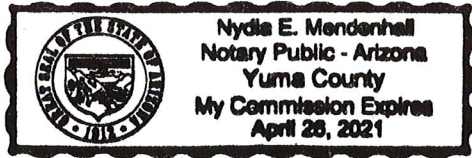

ACCEPTED AND APPROVED BY:

CITY OF SAN LUIS, ARIZONA an
ARIZONA MUNICIPAL CORPORATION

By _____
Gerardo Sanchez, Mayor

ATTEST:

Sonia Cornelio, City Clerk

APPROVED AS TO FORM:

Kay Marion Macuil, City Attorney



AGENDA ITEM REVIEW FORM

Regular City Council Meeting

6. G.

Meeting Date: 01/08/2020

Department Head: Jose A. Guzman, Director of Planning & Zoning, Planning & Zoning Department

Submitted By: Jose A. Guzman, Director of Planning & Zoning, Planning & Zoning Department

Action Requested: Motion
Resolution

ITEM:

Discussion and possible action on any and all matters regarding Resolution No. 2113. A resolution of the Mayor and City Council of the City of San Luis, Arizona, declaring its intention to provide the Enhanced Municipal Services of operating and maintaining certain retention basins within the area described as Santa Cecilia No. 4 Subdivision, San Luis, Arizona. **(Jose A. Guzman, Director of Planning & Zoning)**

SUMMARY:

As a requirement of the City of San Luis Subdivision Regulations, an Enhanced Municipal Services Improvement District is required for new subdivisions. The city has received a petition to form an Enhanced Municipal Services Improvement District for operating and maintaining certain retention basins within the area described as Santa Cecilia No. 4 Subdivision. This is the resolution to create that district.

RECOMMENDATION / SUGGESTED MOTION:

I MOVE TO APPROVE AND ADOPT RESOLUTION NO. 2113.

N/A

Fiscal Impact

IS THERE FISCAL IMPACT ASSOCIATED WITH THIS ITEM: N/A

CITY/STATE/FEDERAL FUNDS: N/A

TOTAL: N/A

BUDGETED AMOUNT: N/A

AVAILABLE AMOUNT TO TRANSFER: N/A

ACCT NAME & GL#/REMAINING BALANCE BEFORE PURCHASE: N/A

FISCAL IMPACT STATEMENT (IF THIS IS A BUDGET TRANSFER, YOU MUST ATTACH THE BUDGET ADJUSTMENT FORM):

N/A

Attachments

Resolution No. 2113



Resolution

OFFICE OF THE
MAYOR
CITY OF SAN LUIS

No. 2113

A RESOLUTION OF THE MAYOR AND CITY COUNCIL OF THE CITY OF SAN LUIS, ARIZONA, DECLARING ITS INTENTION TO PROVIDE THE ENHANCED MUNICIPAL SERVICE IMPROVEMENT DISTRICT OF OPERATING AND MAINTAINING CERTAIN RETENTION BASINS WITHIN THE AREA DESCRIBED AS SANTA CECILIA NO. 4 SUBDIVISION, SAN LUIS, ARIZONA.

WHEREAS, a petition for enhanced municipal services has been presented by all of the real property owners of record for the real property described as Santa Cecilia No. 4 Subdivision, San Luis, Arizona.

NOW, THEREFORE, BE IT RESOLVED, by the Mayor and Council of the City of San Luis, Arizona, as follows:

Section 1: The City of San Luis hereby creates an enhanced municipal services district to be tentatively known as Santa Cecilia No. 4 Municipal Services Improvement District for the area described as Santa Cecilia No. 4 Subdivision, City of San Luis, Arizona, and as further shown on the subdivision plat or plats of record for Santa Cecilia No. 4 Subdivision with the Office of Public Works Director and the Office of City Engineer of the City of San Luis, Arizona. The legal description for the district is as follows:

See exhibit A attached hereto.

Section 2: That the public interest and convenience require, and it is the intention of the governing body of the City of San Luis to provide, for the enhance municipal services of the operation and maintenance of retention basins described as Santa Cecilia No. 4 Subdivision, City of San Luis, Arizona.

Section 3: That the operation and maintenance of said retention basins shall be in accordance with the plan showing location, type and character of the enhanced municipal services, as well as duplicate diagrams of the property contained within the improvement district which is here by approved and adopted by the Council of the City of San Luis, Arizona, and on file in the office of the City Engineer, tentatively known as Santa Cecilia No. 4 Municipal Services Improvement District.

Section 4: That all lots within the Improvement District will benefit by the enhanced municipal services of the operation and maintenance of said retention basins

at a higher level or greater degree than provided in the remainder of the City of San Luis that is not included in the Improvement District.

That the City Council shall make an annual statement and/or statements of the expenses relative to the District for the operation and maintenance of said retention basins which shall be provided by the levy and collection of the ad valorem taxes of the assessed value of all property, real and personal, in the District as provided in Title 48 of the Arizona Revised Statutes, which taxes shall be collected in the amount shown by the statement adopted by the City Council.

PASSED AND ADOPTED by the Mayor and City Council of the City of San Luis, Arizona, this _____ day of _____, 2020.

Gerardo Sanchez, Mayor

ATTEST:

APPROVED AS TO FORM:

Sonia Cornelio, City Clerk

Kay Marion Macuil, City Attorney

**PETITION, WAIVER AND CONSENT TO FORMATION
OF AN ENHANCED MUNICIPAL SERVICES IMPROVEMENT DISTRICT
BY THE CITY OF SAN LUIS NEW SUBDIVISION, SANTA CECILIA NO. 4
(OWNER: RIEDEL HOLDINGS, LLC)**

**To: Honorable Mayor and City Council
 City of San Luis, Arizona**

Pursuant to Arizona Revised Statutes, Section 48-571 to 48-617, as amended, and specifically A.R.S. §48-575 and §48-576 the undersigned property owner respectfully petitions the City Council of the City of San Luis, Arizona ("City Council") to order the formation of an Enhanced Municipal Service District ("District") under Arizona Revised Statutes, Title 48 Chapter 4, Article 2. In support of this petition, the undersigned agrees to waive certain rights under the Arizona Improvement District Law and to consent to the formation and completion of the District.

1. Area of District. The proposed district is described by a map and by a legal description of "Exhibit A" which is attached hereto and incorporated herein by reference. The proposed District consists of approximately 36.79 acres and is entirely within the corporate boundaries of the City of San Luis.
2. Ownership. The undersigned (is) (are) the sole owner(s) of the real property within the proposed District (the "Petitioner(s)") including any required public dedications of property.
3. Purpose. The District is proposed to be formed for the purpose of the operation, maintenance, repair and improvements of retention basins within in Santa Cecilia No. 4 Subdivision.
4. Public Convenience and Necessity. The necessity for the proposed District is for the operation, maintenance, repair and improvements of retention basins within the proposed District by the levying of special assessments in the proposed District.
5. Waiver and Consent. The Petitioners with full knowledge of their rights being waived hereunder, hereby expressly waive all of the following:
 - (a) Any and all irregularities, illegalities or deficiencies which may exist in the acts or proceedings resulting in the adoption of the Resolution of Intention and Resolution Ordering the Work relating to the District;
 - (b) Any necessity for publication and posting of the Resolution of Intention and the Notice of Proposed Improvements;
 - (c) All protest rights, whatsoever under A.R.S. §48-579 (A) and (B) as amended, which provide for protests against the work;
 - (d) All rights to petition to dissolve the district pursuant to A.R.S. §48-574(N); and

(e) All objections to the filing of and adoption by the City of the plans and specifications, the Engineer's estimate and the Assessment Diagram, all of which provide for the completion of the District.

Further the improvements described above are of more than local or ordinary public benefit.

In Witness whereof the parties have executed this Petition and waiver agreement as of the 7 day of January 2020.

<u>PROPERTY OWNER</u>		<u>PROPERTY</u>
<u>NAME, ADDRESS AND</u>		<u>(Tax Parcel Nos.)</u>
<u>SIGNATURE</u>	<u>DATE</u>	
 RIEDEL HOLDINGS, LLC P.O BOX 1649 SAN LUIS, AZ 85349		
By: <u><i>Nieves Riedel</i></u>		<u>APN 227-10-013</u>
Nieves Riedel, Owner		

STATE OF ARIZONA)
)ss.
County of Yuma)

The foregoing acknowledged before me this 07 day of January 2020 by Nieves Riedel, Owner of Riedel Holdings, LLC, an Arizona Corporation, on behalf of said corporation.

My Commission Expires

Nydia E. Mendenhall
Notary Public

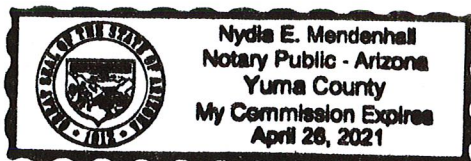

ACCEPTED AND APPROVED BY:

CITY OF SAN LUIS, ARIZONA an
ARIZONA MUNICIPAL CORPORATION

By _____
Gerardo Sanchez, Mayor

ATTEST:

Sonia Cornelio, City Clerk

APPROVED AS TO FORM:

Kay Marion Macuil, City Attorney



AGENDA ITEM REVIEW FORM

Regular City Council Meeting

6. H.

Meeting Date: 01/08/2020

Department Head: Jose A. Guzman, Director of Planning & Zoning, Planning & Zoning Department

Submitted By: Jose A. Guzman, Director of Planning & Zoning, Planning & Zoning Department

Action Requested: Motion
Resolution

ITEM:

Discussion and possible action on any and all matters regarding Resolution No. 2114. A resolution of the Mayor and City Council of the City of San Luis, Arizona declaring its intention of operating, maintaining and repairing certain landscape improvements included within, near and adjacent to the retention and detention basins and parking and parkways and related facilities together with pertinent structures within the area described as Santa Cecilia No. 4 Subdivision, San Luis, Arizona. **(Jose A. Guzman, Director of Planning & Zoning)**

SUMMARY:

As a requirement of the City of San Luis Subdivision Regulations, all developers are responsible to completely landscape their development projects according to the approved plans. In particular, subdivisions are required to provide landscaping along certain arterial and collector streets, in retention basins, and other locations as provided in city regulations. In addition, developers may provide paths, trails, and other amenities in the common open space areas adjacent to arterial and collector streets. Neighborhood landscape amenities add value to properties, enhance walkability, and improve community aesthetics.

The state legislature permits the creation of Municipal Improvement Districts for cities and towns to provide a dedicated funding stream for maintenance, repair, and improvements of pedestrian malls, off-street parking facilities, retention basins, and parking and parkways. This Improvement District will be utilized for landscape maintenance within Santa Cecilia No. 4 Subdivision. Residents within the Improvement District will pay a special assessment on their property tax bill.

This resolution authorizes the creation of Santa Cecilia No. 4 Landscape Improvement District to serve Santa Cecilia No. 4 Subdivision. After approval of this resolution, a second resolution ordering the improvements is needed to finalize the formation of the Improvement District process.

RECOMMENDATION / SUGGESTED MOTION:

I MOVE TO APPROVE AND ADOPT RESOLUTION NO. 2114.

N/A

Fiscal Impact

IS THERE FISCAL IMPACT ASSOCIATED WITH THIS ITEM:	N/A
CITY/STATE/FEDERAL FUNDS:	N/A
TOTAL:	N/A

BUDGETED AMOUNT: N/A

AVAILABLE AMOUNT TO TRANSFER: N/A

ACCT NAME & GL#/REMAINING BALANCE BEFORE PURCHASE: N/A

FISCAL IMPACT STATEMENT (IF THIS IS A BUDGET TRANSFER, YOU MUST ATTACH THE BUDGET ADJUSTMENT FORM):

N/A

Attachments

Resolution No. 2114



Resolution

OFFICE OF THE
MAYOR
CITY OF SAN LUIS

No. 2114

A RESOLUTION OF THE MAYOR AND CITY COUNCIL OF THE CITY OF SAN LUIS, ARIZONA DECLARING ITS INTENTION TO PROVIDE THE ENHANCED MUNICIPAL SERVICES OF MAINTAINING AND REPAIRING CERTAIN LANDSCAPE IMPROVEMENTS INCLUDED WITHIN, NEAR AND ADJACENT TO THE RETENTION BASINS AND PARKING AND PARKWAYS AND RELATED FACILITIES TOGETHER WITH PERTINENT STRUCTURES WITHIN THE AREA DESCRIBED AS SANTA CECILIA NO. 4 LANDSCAPE IMPROVEMENT DISTRICT, SAN LUIS, ARIZONA.

WHEREAS, pursuant to Title 48, Chapter 4, Article 2, Arizona Revised Statutes, a Municipal Improvement District (MID) may be formed for the sole purpose of the operation maintenance, repair and improvements of pedestrian malls, off-street parking facilities, retention and detention basins, and parkings and parkways;

WHEREAS, a petition has been received by Mayor and City Council of the City of San Luis to form a MID to provide operation, maintenance and repair of the landscape improvements within, near and adjacent to the retention and detention basins and the parkings and parkways and related improvements in the Santa Cecilia No. 4;

WHEREAS, the formation of a MID for the operation, maintenance and repair of the landscape improvements within, near, and adjacent to retention and detention basins and the parkings and parkways and related improvements serving Santa Cecilia No. 4 will provide a dedicated stream of funding for the maintenance of those improvements and will provide neighborhood decisions on those improvements, and will privatize the maintenance of those improvements;

WHEREAS, the Mayor and City Council of the City of San Luis, Arizona, find and declare that the formation of the MID to provide the operation, maintenance and repair of the landscape improvements within, near, and adjacent to the retention and detention basins and the parkings and parkways and related improvements in the Santa Cecilia No. 4 to be of more than local or ordinary public benefit, and not a general public benefit, and further that the expenses of said operation, maintenance, and repair shall be Santa Cecilia No. 4 District;

WHEREAS, the Mayor and City Council of the City of San Luis, Arizona, find and declare that the operation, maintenance, and repair of landscaping improvements in the retention and detention basins and the parkings and parkways and related improvements in the District is incidental to the maintenance and preservation of the

retention and detention basins and the parkings and parkways and related improvements, has aesthetic value, and maintains and increases the value of property within the District;

WHEREAS, the Mayor and City Council of the City of San Luis, Arizona find and declare that the operation, maintenance, and repair of landscaping improvements within, near or adjacent to the retention and detention basins and the parkings and parkways and related improvements in the MID preserves and promotes the health, safety, and welfare of those citizens living within the District as well as preservation of the streets and parkways in the District which may be adversely impacted by drainage; and,

WHEREAS, the Mayor and City Council of the City of San Luis, Arizona find and declare that the operation, maintenance, and repair of a landscaped buffer between a parkway and the adjacent developments reduces the visual and other impact of light, air, and noise pollution and tends to increase personal and vehicular safety on the parkway and decreases the likelihood vehicular accidents will harm adjacent developments in furtherance of the health, safety and welfare of those citizens living within the District.

NOW THEREFORE, BE IT RESOLVED by the City Council of the City of San Luis as follows:

SECTION 1: The petition to form a MID for Santa Cecilia No. 4 purporting to be signed by all of the real property owners within the proposed District attached as Exhibit "A" is hereby accepted as provided in A.R.S. § 48-574(C).

SECTION 2: Santa Cecilia No. 4 Landscape, serving Santa Cecilia No. 4 to operate, maintain and repair landscaping improvements included within, near, and adjacent to the retention and detention basins and parkings and parkways and related facilities together with appurtenant structures of Santa Cecilia No. 4, is hereby created.

SECTION 3: The expenses of Santa Cecilia No. 4 Landscape shall be assessed to the several properties within the MID as provided for in A.R.S. § 48-574 et seq.

SECTION 4: No sooner than fifteen (15) calendar days after this Resolution is adopted, City staff shall present a legal description of the boundary for Santa Cecilia No. 4 Landscape and a diagram for Santa Cecilia No. 4 Landscape to Mayor and City Council for consideration to declare an intention to order improvements to Santa Cecilia No. 4 Landscape as provided in A.R.S. § 48-576.

[Remainder of page left intentionally blank. Signature page follows.]

PASSED AND ADOPTED by the Mayor and City Council of the City of San Luis, Arizona, this _____ day of _____, 2020.

Gerardo Sanchez, Mayor

ATTEST:

Sonia Cornelio, City Clerk

APPROVED AS TO FORM:

Kay Marion Macuil, City Attorney

**PETITION, WAIVER AND CONSENT TO FORMATION
OF A MUNICIPAL IMPROVEMENT DISTRICT
BY THE CITY OF SAN LUIS NEW SUBDIVISION, SANTA CECILIA NO. 4
(OWNER: RIEDEL HOLDINGS, LLC)**

**To: Honorable Mayor and City Council
 City of San Luis, Arizona**

Pursuant to Arizona Revised Statutes ("A.R.S.") §48-574, the undersigned property owner respectfully petitions the Mayor and City Council of the City of San Luis, Arizona (the "City Council") to order the formation of a Municipal Improvement District (the "District") under A.R.S., Title 48, Chapter 4, Article 2. In support of this petition, the undersigned agrees to waive certain rights under Arizona Improvement District Law and to consent to the formation and completion of the District.

1. Area of District. The proposed District is described by a map/diagram and by a legal description on "Exhibit A" that is attached hereto and incorporated herein by reference. The proposed District consists of 36.79 acres and is entirely within the corporate boundaries of the City of San Luis.
2. Ownership. The undersigned (is) (are) the sole owner(s) of the real property within the proposed District (the "Petitioner(s)") including any required public dedications of property.
3. Purpose. The District is proposed to be formed for the purpose of the operation, maintenance, repair and improvements of landscape, irrigation, and hardscape in parkways and parkings adjacent to designated public roadways within the proposed District.
4. Public Convenience and Necessity. The necessity for the proposed District is for the operation, maintenance, repair and improvements of landscape, irrigation, and hardscape in parkways and parkings adjacent to designated public roadways within the proposed District by the levying of special assessments in the proposed District.
5. Waiver and Consent. The Petitioners, with full knowledge of their rights being waived hereunder, hereby expressly waive all of the following:
 - (a) Any and all irregularities, illegalities or deficiencies which may exist in the acts or proceedings resulting in the adoption of the Resolution of Intention and the Resolution Ordering the Work relating to the District.
 - (b) Any necessity for publication and posting of the Resolution of Intention and the Notice of Proposed Improvements pursuant to A.R.S §48-578.
 - (c) All rights to petition to dissolve the district pursuant to A.R.S. §48-574(N).
 - (d) All protest rights whatsoever under A.R.S. §48-579(A) and (B) as amended, which provide for protests against the work; and

(e) All objections to the filing of and legislative adoption by the City Council of the plans and specifications, the Engineer's estimate and the Assessment Diagram, all of which provide for the completion of the District.

Further, the improvements described above are of more than local or ordinary public benefit, and not a general public benefit.

In Witness whereof the parties have executed this Petition and waiver agreement as of the 7 day of JANUARY 2020.

<u>PROPERTY OWNER</u> <u>NAME, ADDRESS AND</u> <u>SIGNATURE</u>	<u>DATE</u>	<u>PROPERTY</u> <u>(Tax Parcel Nos.)</u>
RIEDEL HOLDINGS, LLC P.O BOX 1649 SAN LUIS, AZ 85349 By: <u>[Signature]</u> Nieves Riedel, Owner		<u>APN 227-10-013</u>

STATE OF ARIZONA)
)ss.
County of Yuma)

The foregoing acknowledged before me this 07 day of January 2020 by Nieves Riedel, Owner of Riedel Holdings, LLC, an Arizona Corporation, on behalf of said corporation.

My Commission Expires

[Signature]
Notary Public

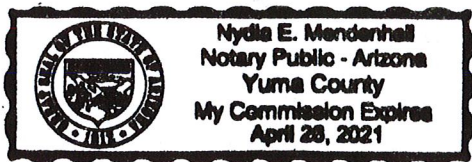

ACCEPTED AND APPROVED BY:

CITY OF SAN LUIS, ARIZONA an
ARIZONA MUNICIPAL CORPORATION

By _____
Gerardo Sanchez, Mayor

ATTEST:

Sonia Cornelio, City Clerk

APPROVED AS TO FORM:

Kay Marion Macuil, City Attorney

SANTA CECILIA No. 4 SUBDIVISION

A SUBDIVISION OF LOT 3A OF SANTA CECILIA LOT TIE/LOT SPLIT AS RECORDED IN BOOK 30 OF PLATS,
 PAGE 98, YUMA COUNTY RECORDER'S OFFICE, YUMA COUNTY, ARIZONA
 AND A PORTION OF THE NW/4 SE1/4 OF SECTION 10, T11S, R24W, G.&S.R.B.&M., YUMA COUNTY, ARIZONA
 DATE OF PREPARATION: AUGUST 2018 NUMBER OF LOTS: 173 ACREAGE: 36.79 ACRES

FINAL PLAT

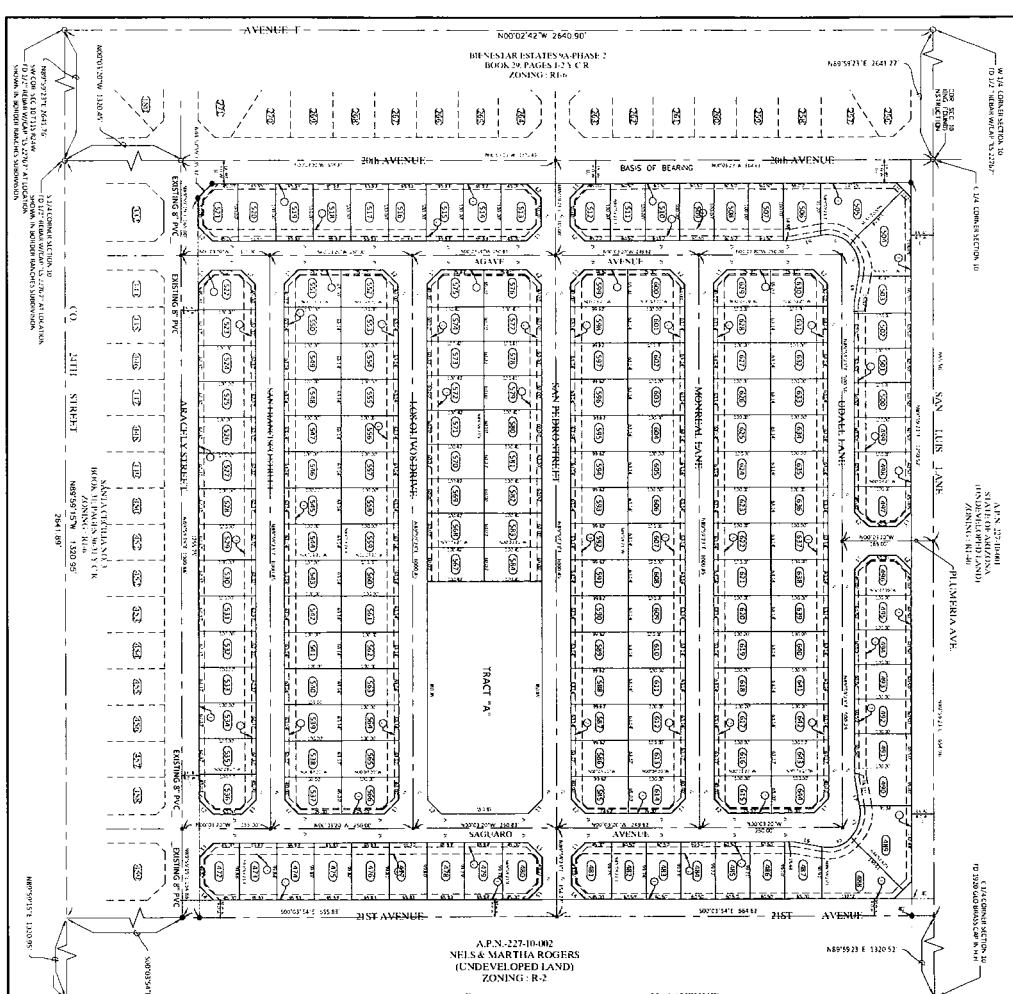

CURVE DATA		LINE DATA							
CURVE	DELTA	CHORD DIRECTION	CHORD BEARING	CHORD RADIUS	CHORD LENGTH	LINE LENGTH	BEARING	LINE LENGTH	BEARING
C1	134.63°	S87°17'35\"	S87°17'35\"	134.63'	18.30'	18.30'	N45°31'09\"	18.30'	S87°17'35\"
C2	134.63°	S87°17'35\"	S87°17'35\"	134.63'	18.30'	18.30'	N45°31'09\"	18.30'	S87°17'35\"
C3	134.63°	S87°17'35\"	S87°17'35\"	134.63'	18.30'	18.30'	N45°31'09\"	18.30'	S87°17'35\"
C4	134.63°	S87°17'35\"	S87°17'35\"	134.63'	18.30'	18.30'	N45°31'09\"	18.30'	S87°17'35\"
C5	134.63°	S87°17'35\"	S87°17'35\"	134.63'	18.30'	18.30'	N45°31'09\"	18.30'	S87°17'35\"
C6	134.63°	S87°17'35\"	S87°17'35\"	134.63'	18.30'	18.30'	N45°31'09\"	18.30'	S87°17'35\"
C7	134.63°	S87°17'35\"	S87°17'35\"	134.63'	18.30'	18.30'	N45°31'09\"	18.30'	S87°17'35\"

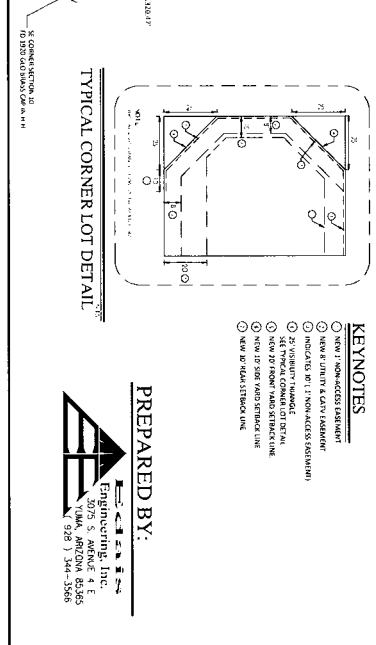

KEYNOTES

- 1. NEW 1/2 ACRE ACCESS EASEMENT
- 2. NEW 1/2 ACRE ACCESS EASEMENT
- 3. INSULATE BY 1 INCHES (SEE SCHEDULE)
- 4. 20' WINDSHIELD
- 5. SET TRUCK CURB OUT FROM TRUCK
- 6. SET TRUCK CURB IN FROM TRUCK
- 7. NEW 1/2 ACRE ACCESS EASEMENT
- 8. NEW 1/2 ACRE ACCESS EASEMENT

PREPARED BY:
Engineering Inc.
 2025 S AVENUE #100
 SUITE 100
 YUMA, ARIZONA 85405
 (928) 344-3586

LEGEND

- 1. BOUNDARY LINE
- 2. EASEMENT
- 3. EASEMENT
- 4. EASEMENT
- 5. EASEMENT
- 6. EASEMENT
- 7. EASEMENT
- 8. EASEMENT
- 9. EASEMENT
- 10. EASEMENT
- 11. EASEMENT
- 12. EASEMENT
- 13. EASEMENT
- 14. EASEMENT
- 15. EASEMENT
- 16. EASEMENT
- 17. EASEMENT
- 18. EASEMENT
- 19. EASEMENT
- 20. EASEMENT
- 21. EASEMENT
- 22. EASEMENT
- 23. EASEMENT
- 24. EASEMENT
- 25. EASEMENT
- 26. EASEMENT
- 27. EASEMENT
- 28. EASEMENT
- 29. EASEMENT
- 30. EASEMENT
- 31. EASEMENT
- 32. EASEMENT
- 33. EASEMENT
- 34. EASEMENT
- 35. EASEMENT
- 36. EASEMENT
- 37. EASEMENT
- 38. EASEMENT
- 39. EASEMENT
- 40. EASEMENT
- 41. EASEMENT
- 42. EASEMENT
- 43. EASEMENT
- 44. EASEMENT
- 45. EASEMENT
- 46. EASEMENT
- 47. EASEMENT
- 48. EASEMENT
- 49. EASEMENT
- 50. EASEMENT
- 51. EASEMENT
- 52. EASEMENT
- 53. EASEMENT
- 54. EASEMENT
- 55. EASEMENT
- 56. EASEMENT
- 57. EASEMENT
- 58. EASEMENT
- 59. EASEMENT
- 60. EASEMENT
- 61. EASEMENT
- 62. EASEMENT
- 63. EASEMENT
- 64. EASEMENT
- 65. EASEMENT
- 66. EASEMENT
- 67. EASEMENT
- 68. EASEMENT
- 69. EASEMENT
- 70. EASEMENT
- 71. EASEMENT
- 72. EASEMENT
- 73. EASEMENT
- 74. EASEMENT
- 75. EASEMENT
- 76. EASEMENT
- 77. EASEMENT
- 78. EASEMENT
- 79. EASEMENT
- 80. EASEMENT
- 81. EASEMENT
- 82. EASEMENT
- 83. EASEMENT
- 84. EASEMENT
- 85. EASEMENT
- 86. EASEMENT
- 87. EASEMENT
- 88. EASEMENT
- 89. EASEMENT
- 90. EASEMENT
- 91. EASEMENT
- 92. EASEMENT
- 93. EASEMENT
- 94. EASEMENT
- 95. EASEMENT
- 96. EASEMENT
- 97. EASEMENT
- 98. EASEMENT
- 99. EASEMENT
- 100. EASEMENT

OWNER
 RIEDEL HOLDINGS, LLC

TRACT AREAS

SURVEYORS CERTIFICATE

LOCATION MAP



AGENDA ITEM REVIEW FORM

Regular City Council Meeting

6. I.

Meeting Date: 01/08/2020

Department Head: Jose A. Guzman, Director of Planning & Zoning, Planning & Zoning Department

Submitted By: Jose A. Guzman, Director of Planning & Zoning, Planning & Zoning Department

Action Requested: Motion
Resolution

ITEM:

Discussion and possible action on any and all matters regarding Resolution No. 2115. A resolution of the Mayor and City Council of the City of San Luis, Arizona, authorizing and directing the city engineer to order the purchase of electricity and to order the maintenance of poles, luminaries and underground conduit incident to the installation of street lights for lighting public streets within the area described as Santa Cecilia No. 4 Subdivision, San Luis, Arizona. **(Jose A. Guzman, Director of Planning & Zoning)**

SUMMARY:

Once a resolution creating a Street Lighting Improvement District is approved, a resolution authorizing work and approving the implementation of the district is required. This is the resolution implementing Santa Cecilia No. 4 Street Lighting Improvement District.

RECOMMENDATION / SUGGESTED MOTION:

I MOVE TO APPROVE RESOLUTION NO. 2115.

N/A

Fiscal Impact

IS THERE FISCAL IMPACT ASSOCIATED WITH THIS ITEM: N/A

CITY/STATE/FEDERAL FUNDS: N/A

TOTAL: N/A

BUDGETED AMOUNT: N/A

AVAILABLE AMOUNT TO TRANSFER: N/A

ACCT NAME & GL#/REMAINING BALANCE BEFORE PURCHASE: N/A

FISCAL IMPACT STATEMENT (IF THIS IS A BUDGET TRANSFER, YOU MUST ATTACH THE BUDGET ADJUSTMENT FORM):

N/A

Attachments

Resolution No. 2115



Resolution

OFFICE OF THE
MAYOR
CITY OF SAN LUIS

No. 2115

A RESOLUTION OF THE MAYOR AND CITY COUNCIL OF THE CITY OF SAN LUIS, ARIZONA, AUTHORIZING AND DIRECTING THE CITY ENGINEER TO ORDER THE PURCHASE OF ELECTRICITY AND TO ORDER THE MAINTENANCE OF POLES, LUMINARIES AND UNDERGROUND CONDUIT INCIDENT TO THE INSTALLATION OF STREET LIGHTS FOR LIGHTING PUBLIC STREETS WITHIN THE AREA DESCRIBED AS SANTA CECILIA NO. 4 SUBDIVISION, SAN LUIS, ARIZONA.

WHEREAS, the Mayor and City Council did pass Resolution of Intention No. 2112 for Santa Cecilia No. 4 Street Lighting Improvement District declaring the intention of the City to purchase electricity including a charge for the use of lighting facilities; and

WHEREAS, the cost of lighting is to be assessed on certain district known as Santa Cecilia No. 4 Street Lighting Improvement District; and

WHEREAS, the petition for street lighting improvement district which was used to create Santa Cecilia No. 4 Street Lighting Improvement District was signed by all of the real property owners within said district and A.R.S § 48-617.A authorizes the immediate jurisdiction to adopt a resolution ordering the improvements, pursuant to the provisions of A.R.S. S 48-581, without the necessity of publication and posting of the resolution of intention provided for in A.R.S § 48-578.

NOW, THEREFORE, BE IT RESOLVED, by the Mayor and Council of the City of San Luis, Arizona, that the City Engineer be empowered and directed to proceed with the improvement of Santa Cecilia No. 4 Street Lighting Improvement District.

[Remainder of page left intentionally blank, signature page follows.]

PASSED AND ADOPTED by the Mayor and City Council of the City of San Luis, Arizona, this _____ day of _____, 2020.

Gerardo Sanchez, Mayor

ATTEST:

Sonia Cornelio, City Clerk

APPROVED AS TO FORM:

Kay Marion Macuil, City Attorney



AGENDA ITEM REVIEW FORM

Regular City Council Meeting

6. J.

Meeting Date: 01/08/2020

Department Head: Jose A. Guzman, Director of Planning & Zoning, Planning & Zoning Department

Submitted By: Jose A. Guzman, Director of Planning & Zoning, Planning & Zoning Department

Action Requested: Motion
Resolution

ITEM:

Discussion and possible action on any and all matters regarding Resolution No. 2116. A resolution of the Mayor and City Council of the City of San Luis, Arizona, authorizing and directing the city engineer to order the operation and maintenance of certain retention basins for the area described as Santa Cecilia No. 4 Subdivision, San Luis, Arizona. **(Jose A. Guzman, Director of Planning & Zoning)**

SUMMARY:

Once a resolution creating an Enhanced Municipal Services Improvement District is approved, a resolution authorizing work and approving the implementation of the district is required. This is the resolution implementing Santa Cecilia No. 4 Enhanced Municipal Improvement District.

RECOMMENDATION / SUGGESTED MOTION:

I MOVE TO APPROVE RESOLUTION NO. 2116.

N/A

Fiscal Impact

IS THERE FISCAL IMPACT ASSOCIATED WITH THIS ITEM: N/A

CITY/STATE/FEDERAL FUNDS: N/A

TOTAL: N/A

BUDGETED AMOUNT: N/A

AVAILABLE AMOUNT TO TRANSFER: N/A

ACCT NAME & GL#/REMAINING BALANCE BEFORE PURCHASE: N/A

FISCAL IMPACT STATEMENT (IF THIS IS A BUDGET TRANSFER, YOU MUST ATTACH THE BUDGET ADJUSTMENT FORM):

N/A

Attachments

Resolution No. 2116



Resolution

OFFICE OF THE
MAYOR
CITY OF SAN LUIS

No. 2116

A RESOLUTION OF THE MAYOR AND CITY COUNCIL OF THE CITY OF SAN LUIS, ARIZONA, AUTHORIZING AND DIRECTING THE CITY ENGINEER TO ORDER THE OPERATION AND MAINTENANCE OF CERTAIN RETENTION BASINS FOR THE AREA DESCRIBED AS SANTA CECILIA NO. 4 SUBDIVISION, SAN LUIS, ARIZONA.

WHEREAS, the Mayor and City Council did pass Resolution of Intention No. 2113 for Santa Cecilia No. 4 Municipal Services Improvement District declaring the intention of the City to operate and maintain certain retention basins for an area described as Santa Cecilia No. 4 Subdivision, San Luis, Arizona; and

WHEREAS, the cost of operating and maintaining said retention basins is to be assessed on a certain district known as Santa Cecilia No. 4 Municipal Services Improvement District; and

WHEREAS, the petition for enhanced municipal services improvement district which was used to create the Santa Cecilia No. 4 Municipal Services Improvement District was signed by all of the real property owners within said district and A.R.S. § 48-575 C. authorized the immediate jurisdiction to adopt a resolution ordering the improvements, pursuant to the provision of A.R.S. § 48-581, without the necessity of publication and posting of the resolution of intention provided for in A.R.S § 48-578.

NOW, THEREFORE, BE IT RESOLVED, by the Mayor and Council of the City of San Luis, Arizona, that the City Engineer be empowered and directed to proceed with the enhanced municipal services of the improvement of Santa Cecilia No. 4 Municipal Services Improvement District.

[Remainder of page left intentionally blank. Signature page follows.]

PASSED AND ADOPTED by the Mayor and City Council of the City of San Luis, Arizona, this _____ day of _____, 2020.

Gerardo Sanchez, Mayor

ATTEST:

Sonia Cornelio, City Clerk

APPROVED AS TO FORM:

Kay Marion Macuil, City Attorney



AGENDA ITEM REVIEW FORM

Regular City Council Meeting

6. K.

Meeting Date: 01/08/2020

Department Head: Jose A. Guzman, Director of Planning & Zoning, Planning & Zoning Department

Submitted By: Jose A. Guzman, Director of Planning & Zoning, Planning & Zoning Department

Action Requested: Motion
Resolution

ITEM:

Discussion and possible action on any and all matters regarding Resolution No. 2117. A resolution of the Mayor and City Council of the City of San Luis, Arizona, authorizing and ordering the operation, maintenance and repair of certain landscape improvements included within, near and adjacent to the retention and detention basins and parkings and parkways and related facilities together with pertinent structures for the area described as Santa Cecilia No. 4 Subdivision, San Luis, Arizona. **(Jose A. Guzman, Director of Planning & Zoning)**

SUMMARY:

Once a resolution creating a Municipal Improvement District is approved, a resolution authorizing work and approving the implementation of the district is required. This is the resolution implementing the Santa Cecilia No. 4 Landscape Improvement District.

RECOMMENDATION / SUGGESTED MOTION:

I MOVE TO APPROVE RESOLUTION NO. 2117.

N/A

Fiscal Impact

IS THERE FISCAL IMPACT ASSOCIATED WITH THIS ITEM: N/A

CITY/STATE/FEDERAL FUNDS: N/A

TOTAL: N/A

BUDGETED AMOUNT: N/A

AVAILABLE AMOUNT TO TRANSFER: N/A

ACCT NAME & GL#/REMAINING BALANCE BEFORE PURCHASE: N/A

FISCAL IMPACT STATEMENT (IF THIS IS A BUDGET TRANSFER, YOU MUST ATTACH THE BUDGET ADJUSTMENT FORM):

N/A

Attachments

Resolution No. 2117

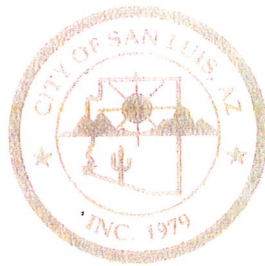

Resolution

OFFICE OF THE
MAYOR
CITY OF SAN LUIS

No. 2117

A RESOLUTION OF THE MAYOR AND CITY COUNCIL OF THE CITY OF SAN LUIS, ARIZONA, ORDERING IMPROVEMENTS FOR THE MUNICIPAL IMPROVEMENT DISTRICT, SERVING SANTA CECILIA NO. 4, TO OPERATE, MAINTAIN AND REPAIR LANDSCAPING IMPROVEMENTS INCLUDED WITHIN, NEAR AND ADJACENT TO THE RETENTION AND DETENTION BASINS AND PARKINGS AND PARKWAYS AND RELATED FACILITIES TOGETHER WITH THE APPURTENANT STRUCTURES OF SANTA CECILIA NO. 4 LANDSCAPE IMPROVEMENT DISTRICT.

WHEREAS, the Mayor and City Council did pass Resolution of intention No. 2114 declaring the intention to create Santa Cecilia No. 4 Landscape Improvement District to operate, maintain, and repair certain landscape improvements within, near, and adjacent to the retention and detention basins and the parkings and parkways and related improvements (Landscape Improvements) in the Santa Cecilia No. 4 Subdivision;

WHEREAS, the petition to form Santa Cecilia No. 4 Landscape Improvement District was signed by all of the real property owners within the proposed District and A.R.S. § 574(C) authorizes City Council to adopt the resolution ordering the improvements, pursuant to the provision of A.R.S. § 48-581, without the necessity of publication and positing of the resolution of intention provided for in A.R.S. § 48-578.

WHEREAS, a legal description of the boundary for Santa Cecilia No. 4 Landscape Improvement District and a diagram for Santa Cecilia No. 4 Landscape Improvement District has been presented to City Council for consideration in this declaration of intention to order Santa Cecilia No. 4 Landscape Improvement District as provided in A.R.S. § 48-576.

NOW, THEREFORE, BE IT RESOLVED by the City Council of the City of San Luis, Arizona, as follows:

SECTION 1: City Council orders Landscape Improvements for Santa Cecilia No. 4 Landscape Improvement District serving Santa Cecilia No. 4 Subdivision. Once the Landscape Improvements are approved and constructed by the developer, the estimate of the cost and expenses shall be placed on file with the City Clerk and presented to City Council in accordance with the provisions of A.R.S. § 48- 574.

SECTION 2: City Council finds the Landscape Improvements for Santa Cecilia No. 4 Landscape Improvement District are of more than local or ordinary public benefit, and are of special benefit to the respective lots, parcels and pieces of land within the described real property of Santa Cecilia No. 4 Landscape Improvement District. City Council orders the cost and expense for the Landscape Improvements of Santa Cecilia No. 4 Landscape Improvement District be chargeable upon the real and personal property within Santa Cecilia No. 4 Landscape Improvement District. City Council declares that Santa Cecilia No. 4 Landscape Improvement District is benefited by the Landscape Improvements and the real and personal properties within Santa Cecilia No. 4 Landscape Improvement District are to be assessed the proportional share of the costs and expenses of the Landscape Improvements.

SECTION 3: All proceedings concerning the Landscape Improvements for Santa Cecilia No. 4 Landscape Improvement District, including the calculations for the costs and expenses and all assessments to pay the costs and expenses of the Landscape Improvements, shall be made in accordance with the provisions of Title 48, Chapter 4, Article 2 of the A.R.S., as amended.

SECTION 4: Any public street or alley within the boundaries of Santa Cecilia No. 4 Landscape Improvement District are omitted from the real and personal property of Santa Cecilia No. 4 Landscape Improvement District and shall not be included in the assessment.

SECTION 5: In no event will the City of San Luis or any officer thereof be liable for any portion of the cost of said Improvement District nor any delinquency of persons or property assessed.

SECTION 6: City Council shall make annual statements and estimates of the expenses of the District which shall be provided for by the levy and collection of ad valorem taxes upon the assessed value of all real and personal property within Santa Cecilia No. 4 Landscape Improvement District as provided in A.R.S. § 48- 574, as amended.

[Remainder of page left intentionally blank. Signature page follows.]

PASSED AND ADOPTED by the Mayor and City Council of the City of San Luis, Arizona, this _____ day of _____, 2020.

Gerardo Sanchez, Mayor

ATTEST:

Sonia Cornelio, City Clerk

APPROVED AS TO FORM:

Kay Marion Macuil, City Attorney