



## NOTICE OF REGULAR COUNCIL MEETING

In accordance with §38-431.02 of the Arizona Revised Statutes of the State of Arizona, notice is hereby given to the Members of City Council and to the general public that the Mayor and Council of the City of San Luis, Arizona will hold a Regular City Council meeting at 7:00 p.m., Wednesday, September 23, 2020. The meeting will take place at the City Council Chambers, located at 1090 E. Union Street, San Luis, Arizona, 85349.

In accordance with the Americans with Disabilities Act (ADA) and Section 504 of the Rehabilitation Act of 1973, the City of San Luis does not discriminate on the basis of disability in the admission of or access to, or treatment of employment in its programs, activities, or services. For information regarding rights and provisions of the ADA or Section 504, or to request reasonable accommodations for participation in City programs, activities or services contact: ADA/Section 504 Coordinator, City of San Luis Human Resources Department, 1090 E. Union Street, San Luis, Arizona, 85349; (928) 341-8520.

Notice is hereby given that pursuant to A.R.S. §1-602.A.9, subject to certain specified statutory exceptions, parents have a right to consent before the State or any of its political subdivisions make a video or audio recording of a minor child. Meetings of the City Council are audio and/or video recorded, and, as a result, proceedings in which children are present may be subject to such recordings. Parents in order to exercise their rights may either file written consent with the City Clerk to such recordings, or take personal action to ensure that their child or children are not present when a recording may be made. If a child is present at the time a recording is made, the City will assume that the rights afforded parents pursuant to A.R.S. §1-602.A.9 have been waived.

THIS NOTICE IS GIVEN BY:

/s/ Sonia Cornelio, City Clerk

## AVISO DE JUNTA REGULAR

De acuerdo con los Estatutos del Estado de Arizona A.R.S. §38-431.02, se le informa a los miembros del Cabildo y al público en general que el Alcalde y el Cabildo, tendrán una Junta Regular a las 7:00 p.m., el día Miércoles, 23 de Septiembre del 2020. La junta se llevará a cabo en la Sala del Cabildo, ubicada en el 1090 E. Union Street, San Luis, Arizona, 85349.

De acuerdo con el Acta de Americanos con Discapacidades y la Sección 504 del Acta de Rehabilitación del 1973, la Ciudad de San Luis, Arizona no discrimina por causa de discapacidad la admisión y acceso a sus programas, actividades, servicios o en el trato en cuanto a empleo. Para más información referente a derechos y provisiones del Acta de Americanos con Discapacidades o Sección 504, o para solicitar adaptaciones que sean razonables para la participación en programas, actividades o servicios de la Ciudad, contactar al: Coordinador del Acta de Americanos con Discapacidades/Sección 504, Departamento de Recursos Humanos de la Ciudad de San Luis, Arizona, ubicado en el 1090 E. Union Street, San Luis, Arizona, 85349; (928) 341-8520.

Por medio de este aviso y de acuerdo con los Estatutos del Estado de Arizona A.R.S §1-602.A.9, sujeto a ciertas excepciones reglamentarias, los padres de familia tienen el derecho de dar el consentimiento ante el Estado o cualquiera de sus subdivisiones políticas para hacer una grabación de audio o video de su hijo menor de edad. Las juntas del Cabildo se graban en audio y/o video y como resultado, el hecho de que haya menores presentes puede ser sujeto a que sean grabados. Para que los padres de familia puedan ejercer sus derechos pueden dar el consentimiento por escrito con la Secretaria de la Ciudad a tal grabación, o tomar acción personal para asegurarse que su hijo menor no esté presente cuando la grabación se lleve a cabo. Si un menor de edad está presente en el momento de la grabación, la Ciudad asumirá que los padres de familia están cediendo los derechos sobre una posible grabación de acuerdo con los Estatutos del Estado de Arizona A.R.S. §1-602.A.9.

ESTE AVISO ES DADO POR:

/f/ Sonia Cornelio, Actuaría de la Ciudad



**AGENDA**  
**Regular Meeting**  
**San Luis City Council**  
**San Luis Council Chambers**  
**1090 E. Union Street**  
**San Luis, AZ 85349**  
**September 23, 2020**  
**7:00 p.m.**

The September 23, 2020 Regular Council meeting, for the safety of the public during the COVID-19 pandemic, will not have in-person attendance for members of the public.

However, members of the public may listen to the meeting's live audio stream on the City of San Luis' website <https://sanluisaz.gov/listenlive>. Recordings of the meetings will be available on the City's website <https://sanluisaz.gov/listenlive> after the meeting.

Open meetings conducted remotely through technological means are permissible under the March 13, 2020, Arizona Attorney General opinion titled, "Re: Concerns Relating to Arizona's Open Meeting Law and COVID-19" and following the Mayor's March 18, 2020, Continued Declaration of Emergency and Amended Order-Coronavirus Disease-19 and City Council's Order 2020-7 which closed all city buildings and facilities (except the Municipal Court) to public access.

Por la seguridad del público durante la pandemia COVID-19, no habrá asistencia en persona para los miembros del público en la junta regular del Cabildo del 23 de Septiembre del 2020.

Sin embargo, los miembros del público pueden escuchar el audio en vivo de la reunión transmitido en el sitio web de la Ciudad de San Luis <https://sanluisaz.gov/listenlive>. Las grabaciones de las reuniones estarán disponibles en el sitio web de la Ciudad <https://sanluisaz.gov/listenlive> después de la reunión.

Las reuniones abiertas realizadas de forma remota a través de medios tecnológicos están permitidas bajo la opinión del Fiscal General de Arizona del 13 de marzo de 2020 titulada "Re: Preocupaciones relacionadas con Open Meeting Law de Arizona y COVID-19" y después de la Declaración de Emergencia Continua del 18 de marzo de 2020 del alcalde y Orden modificada-Enfermedad de Coronavirus-19 y Orden del Ayuntamiento 2020-7 la cual cerró todos los edificios e instalaciones de la ciudad (excepto en la Corte Municipal) al acceso público, para proteger la salud y la seguridad pública y reducir la transmisión de la Enfermedad de Coronavirus 2019 (COVID- 19).

**PLEASE TAKE NOTICE THAT MEMBERS OF THE CITY COUNCIL WILL ATTEND EITHER IN PERSON, TELEPHONE, OR VIDEO CONFERENCE COMMUNICATION. THE MAYOR OR ACTING MAYOR FOR THIS MEETING MAY CHANGE THE ORDER OF THE ITEMS; IF AUTHORIZED BY LAW AND BY A MAJORITY VOTE OF A QUORUM OF CITY COUNCIL MEMBERS PRESENT, AN EXECUTIVE SESSION WILL BE HELD IMMEDIATELY FOLLOWING THE VOTE IN ACCORDANCE WITH A.R.S. §38-431.03(A) AND THE MEETING WILL BE TEMPORARILY RECESSED WHILE THE CITY COUNCIL RETIRES TO EXECUTIVE SESSION WHICH WILL NOT BE OPEN TO THE PUBLIC.**

1. **CALL TO ORDER/ROLL CALL**
2. **PLEDGE OF ALLEGIANCE**
3. **INVOCATION**

4. **PROCLAMATION**

4. A. National Custodian Workers Recognition Day - October 2, 2020.

5. **CONSENT AGENDA**

All matters are considered to be routine by the City Council and will be enacted by one motion. If discussion is desired, that item will be removed from the Consent Agenda and will be considered separately.

5. A. **MINUTES OF**

- Work Session held August 19, 2020
- Regular Council meeting held August 26, 2020

5. B. **DISBURSEMENTS FROM AUGUST 29, 2020 THROUGH SEPTEMBER 11, 2020**

**Total Disbursements \$761,474.16**

(Seven Hundred Sixty-One Thousand, Four Hundred Seventy-Four Dollars and Sixteen Cents)

6. **DISCUSSION AND POSSIBLE ACTION ITEMS:**

6. A. Discussion and possible action on any and all matters regarding Resolution No. 2140. A resolution of the Mayor and Council of the City of San Luis, Arizona approving an Addendum to the Intergovernmental Agreement (IGA) between the City of San Luis, Arizona and Yuma County for the purpose of providing mandatory field training. **(Nohemy Echavarria, Magistrate)**
6. B. Discussion and possible action on any and all matters regarding Resolution No. 2141. A resolution of the Mayor and City Council of the City of San Luis, Arizona approving the addendum to the Intergovernmental Agreement (IGA) between the City of San Luis, Arizona and Yuma County for the purpose of providing mandatory weekend and holiday court services for San Luis Municipal Court. **(Nohemy Echavarria, Magistrate)**
6. C. Discussion and possible action on any and all matters regarding Resolution No. 2142. A resolution of the Mayor and City Council of the City of San Luis, Arizona, ratifying and approving the creation of positions in the classified service of the city; amending the classification and service plan of the city; superseding any conflicting provisions of existing regulations or policies; providing for severability; and declaring an emergency. **(Kay Macuil, City Attorney)**
6. D. Discussion and possible action on any and all matters regarding Ordinance No. 401. An ordinance of the Mayor and City Council of the City of San Luis, Arizona, establishing the Department of Parks and Recreation as the authority for the management of trees in the City of San Luis and practices for the care of the trees and removal when in the health, safety and welfare interests of the residents; amending the San Luis City Code; repealing any conflicting provision; providing for severability; providing for penalties; and declaring an emergency. **(Lizandro Galaviz, Director of Parks and Recreation and Mary French-Jones, Grant Writer)**

- A. Action on Reading of Ordinance No. 401 by title only  
(City Clerk to read the ordinance by title only)
- B. Action and adoption of Ordinance No. 401

- 6. E. Discussion and possible action on any and all matters regarding Subdivision Case No. 2020-076F. A request by Riedel Holdings LLC, property owner, for the final plat approval for Riedel Office Condominiums Subdivision to be located on Lot B-1 and B-2 of the Riedel Plaza Shopping Center, San Luis, Arizona. **(Jose A. Guzman, Director of Planning & Zoning)**

- A. Staff presentation
- B. Action on Subdivision Case No. 2020-076F

- 7. **SUMMARY OF CURRENT EVENTS**  
Events by Mayor, Council Members and/or City Manager pursuant to A.R.S. §38-431.02 (K).

- 8. **EXECUTIVE SESSIONS**  
Vote to hold an Executive Sessions pursuant to A.R.S. § 38-431.03(A)(1)(3) and (4).

- 8. A. Discussion and possible action to hold an executive session pursuant to A.R.S. § 38-431.03(A), subsections (1), (3) and (4) on any and all matters relating to the position of Magistrate and the employment, assignment, appointment, promotion, demotion, dismissal, salary, disciplining, or resignation of the position of the Magistrate, including discussion of possible confirmation of the City Manager's appointment of the Magistrate and/or discussion of approval of terms and/or conditions of said appointment pursuant to San Luis City Code §34.20, and consultation with the attorney or attorneys of the City regarding the same. **(Tadeo A. De La Hoya, City Manager)**

- 8. B. Discussion and possible action to hold an executive session pursuant to A.R.S. § 38-431.03(A), subsections (1), (3) and (4) on any and all matters relating to the position of Fire Chief and the employment, assignment, appointment, promotion, demotion, dismissal, salary, disciplining, or resignation of the position of Fire Chief, including discussion of possible confirmation of the City Manager's appointment of the Fire Chief and/or discussion of approval of terms and/or conditions of said appointment pursuant to San Luis City Code §34.04, and consultation with the attorney or attorneys of the city regarding the same. **(Tadeo A. De La Hoya, City Manager)**

- 8. C. Discussion and possible action to hold an executive session pursuant to A.R.S. § 38-431.03 (A), subsections (1), (3) and (4) on any and all matters relating to the position of Chief of Police and the employment, assignment, appointment, promotion, demotion, dismissal, salary, disciplining, or resignation of the position of Chief of Police, including discussion of possible confirmation of the City Manager's appointment of the Chief of Police and/or discussion of approval of terms and/or conditions of said appointment pursuant to San Luis City Code §32.02, and consultation with the attorney or attorneys of the City regarding the same. **(Tadeo A. De La Hoya, City Manager)**

- 9. **MOTION TO GO BACK INTO REGULAR SESSION**

**10. DISCUSSION AND POSSIBLE ACTION ITEMS:**

**10. A.** Discussion and possible action on any and all matters regarding the employment contract for the Magistrate. **(Tadeo A. De La Hoya, City Manager)**

**10. B.** Discussion and possible action on any and all matters regarding the employment contract of the Fire Chief. **(Tadeo A. De La Hoya, City Manager)**

**10. C.** Discussion and possible action on any and all matters regarding the employment contract of the Chief of Police. **(Tadeo A. De La Hoya, City Manager)**

**11. ADJOURNMENT**



# PROCLAMATION

**Regular City Council Meeting**

**4. A.**

Meeting Date: 09/23/2020

---

Title:

National Custodian Workers Recognition Day - October 2, 2020.

---

**Attachments**

Proclamation

---



# *Proclamation*

OFFICE OF THE  
MAYOR  
CITY OF SAN LUIS

**“NATIONAL CUSTODIAN WORKERS RECOGNITION DAY”  
October 2<sup>nd</sup>, 2020**

**WHEREAS**, custodial workers work behind the scenes and are often unappreciated for the hard work that they do day after day keeping schools, hospitals, office buildings, museums, churches, etc., clean and well maintained,

**WHEREAS**, these people are an important part of the success of many businesses as a clean, well maintained, and an operation building is a reflection on the business itself,

**WHEREAS**, the City’s Facilities Department always strive to keep the City’s buildings and offices well maintained and cleaned,

**NOW THEREFORE**, I, Gerardo Sanchez, Mayor of the City of San Luis hereby proclaim October 2<sup>nd</sup>, 2020 as “**National Custodian Workers Recognition Day**” thanking and recognizing the hard work of the City’s Facilities Department and custodians throughout this municipality.

**PASSED AND ADOPTED** this 23rd day of September, 2020.

\_\_\_\_\_  
Gerardo Sanchez, Mayor

**ATTEST:**

\_\_\_\_\_  
Sonia Cornelio, City Clerk



## AGENDA ITEM REVIEW FORM

### Regular City Council Meeting

5. A.

Meeting Date: 09/23/2020

---

#### Summary

#### **MINUTES OF**

- Work Session held August 19, 2020
  - Regular Council meeting held August 26, 2020
- 

#### Attachments

8/19/2020 WS

8/26/2020 RCM

---

**MINUTES**  
**Work Session**  
**San Luis City Council**  
**San Luis Council Chambers**  
**1090 E. Union Street**  
**August 19, 2020**  
**6:30 p.m.**

**1. CALL TO ORDER/ROLL CALL:**

Mayor Gerardo Sanchez called the work session to order at approximately 6:30 p.m.

Mayor and City Council participated remotely due to COVID-19.

**PRESENT:** Mayor Gerardo Sanchez  
Vice Mayor Maria Cecilia Cruz  
Council Member Mario Buchanan Jr.  
Council Member Africa Luna-Carrasco  
Council Member Jose Ponce  
Council Member Matias Rosales  
Council Member Gloria Torres

**OTHERS PRESENT:** Tadeo A. De La Hoya, City Manager  
Sonia Cornelio, City Clerk  
Kay Marion Macuil, City Attorney  
Domingo Sosa, Information Technology Technician  
Eulogio Vera, Director of Public Works  
Francia Alonso, Assistant to Council/PIO  
Glenn Gimbut, Assistant City Attorney  
Jenny Torres, Economic Development Manager  
Jonathan Dumadag, Information Technology Technician  
Jose A. Guzman, Director of Planning Zoning  
Lizandro Galaviz, Director of Parks & Recreation  
Marlene Lara, Government and Foreign Affairs Coordinator  
Ralph Velez, City Consultant (remotely)

**2. ITEM FOR DISCUSSION ONLY:**

**2. A. Discussion and possible directions to staff on any and all matters regarding the Cesar Chavez Boulevard Widening Project. (Jenny Torres, Economic Development Manager; Jose A. Guzman, Director of Planning & Zoning; Eulogio Vera, Director of Public Works; and Lizandro Galaviz, Director of Parks & Recreation)**

Ms. Jenny Torres, Economic Development Manager, Jose A. Guzman, Director of Planning & Zoning, Eulogio Vera, Director of Public Works, and Lizandro Galaviz, Director of Parks & Recreation made a Powerpoint presentation. This presentation included the following slides; Build Grant, Project Estimated Cost, Tentative Schedule, and Parks' Pathways & Bicycle Master Plan. A copy of this presentation is included with the complete agenda packet filed in the City Clerk's Office.

Mr. Vera informed that the design is currently 30% completed, but it will not take long for the project to be at 60%. This project has moved slowly, but it has been continuously moving forward. He stated that it is critical for City Council to understand is that this project is a region significance, this project connects two (2) ports of entry provides better access to the entire region; this project will also give a high level of services for a significant amount of traffic. The Powerpoint presentation includes the design of this project.

Mr. Jose A. Guzman, Director of Planning and Zoning, presented the Pathways & Bicycle Master Plan. Mr. Guzman stated that by including this project, the application for the BUILD grant would be more competitive.

Mr. Lizandro Galaviz, Director of Parks & Recreation, continued the Powerpoint presentation of the Pathways & Bicycle Master Plan which will improve the quality of life to the San Luis residents.

Ms. Torres stated that staff would need the City Council's support on the BUILD Grant application and the Arizona Department of Transportation and Yuma Metropolitan Organization support. She added that these grants are very competitive.

Mayor Gerardo Sanchez thanked Ms. Torres, Mr. Guzman, Mr. Vera, and Mr. Galaviz for the presentation. He stated that as Ms. Torres mentioned, the support for the different agencies will be needed and also from the Arizona Delegation.

Ms. Torres added that regulations on the BUILD Grant changes very often, and if they require a 20% match out of \$33 million, then staff will have to figure out how the matching funds will be obtained.

Members of the City Council thanked staff for their hard work done on this project.

### **3. ADJOURNMENT**

**MOTION:** Council Member Gloria Torres/Council Member Africa Luna-Carrasco to adjourn the work session at approximately 7:05 p.m. Motion passed unanimously.

The vote was as follows:

Mayor Gerardo Sanchez	Aye
Vice Mayor Maria Cecilia Cruz	Aye
Council Member Mario Buchanan Jr.	Aye
Council Member Africa Luna-Carrasco	Aye
Council Member Jose Ponce	Aye
Council Member Matias Rosales	Aye
Council Member Gloria Torres	Aye

**APPROVED:**

---

Gerardo Sanchez, Mayor

**ATTEST:**

---

Sonia Cornelio, City Clerk

### **Certification**

I hereby certify that the foregoing minutes are a true and correct copy of the minutes of the Work Session for the City Council of the City of San Luis, Arizona, held on August 19, 2020. I further certify that the meeting was duly called and held and that a quorum was present.

---

Sonia Cornelio, City Clerk

**MINUTES**  
**Regular Council Meeting**  
**San Luis City Council**  
**San Luis Council Chambers**  
**1090 E. Union Street**  
**August 26, 2020**  
**7:00 p.m.**

**1. CALL TO ORDER/ROLL CALL**

Mayor Gerardo Sanchez called the Regular City Council meeting to order at approximately 7:00 p.m.

Mayor, City Council, and some members of staff participated remotely.

**PRESENT:** Mayor Gerardo Sanchez  
Vice Mayor Maria Cecilia Cruz  
Council Member Mario Buchanan Jr.  
Council Member Jose Ponce  
Council Member Matias Rosales  
Council Member Gloria Torres

**ABSENT:** Jose Ponce

**OTHERS PRESENT:** Tadeo A. De La Hoya, City Manager (remotely)  
Sonia Cornelio, City Clerk  
Kay Marion Macuil, City Attorney  
Axel Chayra, Information Technology Technician  
Derek Dueñas, Manager of Information Technology  
Domingo Sosa, Information Technology Technician  
Enrique Luna, Senior Services Assistant/Driver  
Eulogio Vera, Director of Public Works  
Francia Alonso, Assistant to Council/PIO  
Gilberto Torres, Waste Water Supervisor  
Jenny Torres, Economic Development Manager  
Jorge Mungaray, Information Technology Technician  
Jose L. Cisneros, Executive Assistant  
Jose Guzman, Director of Planning & Zoning  
Marco Santana, Police Lieutenant  
Marlene Lara, Government and Foreign Affairs Coordinator  
Monica Castro, Director of Finance  
Ralph Velez, City Consultant (remotely)  
Richard Jessup, Chief of Police  
Roula Encinas, Accountant II  
Rogelio Martinez, Office Assistant  
Sondra Matthews, Director of Human Resources  
Elizabeth Carpenter, Realtor

## **2. PLEDGE OF ALLEGIANCE**

Council Member Mario Buchanan Jr. led the Pledge of Allegiance.

## **3. INVOCATION**

Mr. Marco Santana, Police Lieutenant, led the invocation.

## **4. PROCLAMATION**

### **4.A. Proclamation - Prostate Cancer Awareness Month - September 2020**

Mrs. Sonia Cornelio, City Clerk, read the proclamation in its entirety.

Mayor Gerardo Sanchez mentioned prostate cancer is something that affects a lot of people, especially if there is a history in the family. It is very important that screens take place early to detect this illness and it is recommended males get screened at 45 years old.

### **4.B. Presentation and recognition of the 2020 - 1st and 2nd Quarter awardees with the Employee Recognition and Awards Program (ERAP) for their outstanding work with the City of San Luis. (Angelica Cifuentes, Rogelio Martinez, ERAP Committee Chairs & Fausto Gonzalez, HR Training & Programs Coordinator)**

Mr. Fausto Gonzalez, HR Training & Programs Coordinator, presented recognitions and awards to the recipients along with Mr. Rogelio Martinez, ERAP Committee Vice-Chair.

Mayor Gerardo Sanchez and Council Members congratulated all the recipients

## **5. CONSENT AGENDA**

### **5.A. MINUTES OF**

- Regular Council meeting held June 24, 2020
- Work Session held July 1, 2020
- Regular Council meeting held July 8, 2020

### **5.B. DISBURSEMENTS FROM AUGUST 1, 2020 THROUGH AUGUST 14, 2020**

**Total Disbursements \$900,229.57**

**(Nine Hundred Thousand, Two Hundred Twenty-Nine Dollars and Fifty-Seven Cents)**

**MOTION:** Council Member Gloria Torres/Council Member Africa Luna-Carrasco to approve the Consent Agenda as presented. Motion passed unanimously.

The vote was as follows:

Mayor Gerardo Sanchez	Aye
Vice Mayor Maria Cecilia Cruz	Aye
Council Member Mario Buchanan Jr.	Aye

Council Member Africa Luna-Carrasco Aye  
Council Member Matias Rosales Aye  
Council Member Gloria Torres Aye

## **6. DISCUSSION AND POSSIBLE ACTION ITEMS:**

### **6.A. Discussion and possible action on any and all matters regarding a contract with James Davey and Associates, Inc., to provide design and engineering services for Mesa Street Improvements. (Jenny Torres, Economic Development Manager)**

Ms. Jenny Torres, Economic Development Manager, explained that every year staff selects a project where a design can be done and submit an Arizona of Housing State Special Project application, which is a competitive grant funding. This year, staff identified Mesa Street as one of the areas that might qualify and that needs improvement. Originally there was a smaller area and staff decided they needed to include an additional area. The original allocation in the capital project budget was \$35,000.00. Due to that additional road being added, the design cost went up to approximately \$38,000.00. She asked the City Council to award the contract to James Davey and Associates, he has been doing most of the city's CDBG projects and understands the needs.

Mr. Eulogio Vera, Director of Public Works, stated the original scope of this project included doing the Mesa alley as well as a portion of C Street, E Street, and a section of Mesa between Cesar Chavez Boulevard and E Street. The necessary alignment between E Street and C Street was added. They are looking is to do additional survey to pick up that area and make sure that if staff was to improve this roadway it would be drained properly. It was not originally included in the project because there is really no room to get a roadway in there at this point. However, knowing that it is downtown and having quite a bit of vacant land, one never knows how that is going to be developed and staff wants to keep its options in the event the city wants a road through Mesa Street; and provide an additional two-way roadway with sidewalk.

**MOTION:** Vice Mayor Maria Cecilia Cruz/Council Member Gloria Torres to approve the contract with James Davey and Associates, Inc., in the amount of \$38,890.00 for engineering services as presented. Motion passed unanimously.

The vote was as follows:

Mayor Gerardo Sanchez Aye  
Vice Mayor Maria Cecilia Cruz Aye  
Council Member Mario Buchanan Jr. Aye  
Council Member Africa Luna-Carrasco Aye  
Council Member Matias Rosales Aye  
Council Member Gloria Torres Aye

### **6.B. Discussion and possible action on any and all matters regarding authorization to increase the financial budget for Fiscal Year 2020-2021**

**necessary to spend remaining funds from the North American Development Bank Technical Assistance Grant awarded and accepted in Fiscal Year 2019-2020. (Jenny Torres, Economic Development Manager)**

Ms. Jenny Torres, Economic Development Manager, stated the North American Development Bank (NADBANK) provided the city with a technical assistance grant last year to develop a feasibility study for natural gas to the east of town. The deadline for this study was June, however due to COVID-19 there were some delays. NADBANK is very specific about making sure that the U.S. and Mexico side is part of this project but staff has been unable to collect the information from San Luis Rio Colorado. There was some congress made and the deadline was extended to August and now staff has to extend it to October. Both NADBANK and Berkley Group accepted the extension request and an another amendment will be needed. This project was not included in the current budget as staff thought it was going to be completed in June and now to include it in the current budget, the current budget needs to be increased to allow the grant money to come in and expenditure.

**MOTION:** Council Member Gloria Torres/Council Member Africa Luna-Carrasco to approve the increase in budget to \$97,544.00 as presented. Motion passed unanimously.

The vote was as follows:

Mayor Gerardo Sanchez	Aye
Vice Mayor Maria Cecilia Cruz	Aye
Council Member Mario Buchanan Jr.	Aye
Council Member Africa Luna-Carrasco	Aye
Council Member Matias Rosales	Aye
Council Member Gloria Torres	Aye

**6.C. Discussion and possible action on any and all matters regarding the City of San Luis entering into the Arizona Mutual Aid Compact with the State of Arizona, the Arizona Department of Emergency and Military Affairs, and all political jurisdictions within the State of Arizona including the Cocopah Indian Tribe and Fort Yuma Quechan Indian Tribe which are parties to the Compact. (Richard Jessup, Chief of Police)**

Mr. Marco Santana, Police Lieutenant, mentioned this mutual aid agreement has many benefits to the department. One of them will be being of mutual aid in case of an emergency and the accreditation the department is currently working on. This project has been worked on since 2018 and with this accreditation, it will demonstrate that the agency is working under best practices. The assessor's for the accreditation will be at the police department and will be conducting their process. This accreditation will assist the police department when applying for grants such as the stone garden and cops grant. With this accreditation the City of San Luis Police Department will be the first agency in Yuma County to achieve this.

**MOTION:** Vice Mayor Maria Cecilia Cruz/Council Member Matias Rosales approve the Arizona Mutual Aid Compact as presented. Motion passed unanimously.

The vote was as follows:

Mayor Gerardo Sanchez	Aye
Vice Mayor Maria Cecilia Cruz	Aye
Council Member Mario Buchanan Jr.	Aye
Council Member Africa Luna-Carrasco	Aye
Council Member Matias Rosales	Aye
Council Member Gloria Torres	Aye

**6.D. Discussion and possible action on any and all matters regarding the bidding process for the construction of the 9B Restroom Facilities Project. (Lizandro Galaviz, Director of Parks & Recreation)**

Mr. Lizandro Galaviz, Director of Parks & Recreation, explained in reviewing the bids staff received for this project, staff is recommending to reject all bids and to look at different alternatives for completing this project either by subbing out and doing some in-house or look into other options such as a prefabricated restroom area or something that would be able to accommodate in that area.

He illustrated sample pictures of the prefabricated restrooms to the Mayor and City Council. There was discussion, questions, and answers amongs Mr. Galaviz, the Mayor and City Council regarding specifications of the restrooms and costs.

**MOTION:** Council Member Matias Rosales/Vice Mayor Maria Cecilia Cruz to reject bids received for the 9B Restroom Facilities Project due to bids being over budget and direct staff to explore cost-effective options. Motion passed unanimously.

The vote was as follows:

Mayor Gerardo Sanchez	Aye
Vice Mayor Maria Cecilia Cruz	Aye
Council Member Mario Buchanan Jr.	Aye
Council Member Africa Luna-Carrasco	Aye
Council Member Matias Rosales	Aye
Council Member Gloria Torres	Aye

**6.E. Discussion and possible action on any and all matters regarding authorization for employee vacation accrual payout. (Tadeo A. De La Hoya, City Manager)**

Mr. Tade A. De La Hoya, City Manager, said this is the same as the item approved by the Mayor and City Council on June 24, 2020, however from the 63 employees, staff missed 10 employees; staff recommends approval on this items.

Mayor Gerardo Sanchez asked if this will be paid from the the 2020-2021 budget. Mr. De La Hoya responded yes, it will be paid with the 2020-2021 fiscal year budget.

**MOTION:** Council Member Matias Rosales/Council Member Africa Luna-Carrasco approve up to \$9,600.00 for vacation payouts in the 2020-2021 Fiscal Year for employees discovered to be eligible but not paid in the 2019-2020 Fiscal Year, and othe than the timing of the payouts, the payouts shall be under the same conditions of the City Council's June 24, 2020, motion. Motion passed unanimously.

The vote was as follows:

Mayor Gerardo Sanchez	Aye
Vice Mayor Maria Cecilia Cruz	Aye
Council Member Mario Buchanan Jr.	Aye
Council Member Africa Luna-Carrasco	Aye
Council Member Matias Rosales	Aye
Council Member Gloria Torres	Aye

**6.F. Discussion and possible action on any and all matters regarding Resolution No. 2138. A resolution of the Mayor and Council of the City of San Luis, Arizona, temporarily suspending imposition of a late penalty charge on water utility accounts; temporarily suspending shut-off of water service for non-payment; and temporarily suspending imposition of shut-off fee due to declared COVID-19 virus emergency; repealing any conflicting provisions; providing for severability; and declaring an emergency. (Jorge Perez, Billing & Collections Manager)**

Mr. Jorge Perez, Billing & Collections Manager, said Resolution No. 2138 is regarding the imposition and suspension of wastewater and trash penalties on utility accounts. This resolution extends the suspension and imposition of these fees for a couple more months due to the corona virus pandemic. The resolution states to last until the declaration of emergency shall terminate or November 1, 2020. Mr. Perez added that this resolution also proposes to start the 10% late penalty charge on utility accounts, which is a penalty on the water bill for customers that do not pay the bill on time by the due date with the billing of November. In addition, this resolution proposed a ceiling balance on delinquent accounts of \$200.00 to begin creating payment plan for those customers that owe more than \$200.00 and to place them on a payment plan to be retired until June 30, 2021.

Mayor Gerardo Sanchez asked if water rates have been increased.

Mr. Perez responded no, the water rates have not increased.

Council Member Mario Buchanan Jr. asked how many delinquent accounts exist, is the city working with these customers and reminding them about their overdue accounts.

Mr. Perez replied that as of yesterday there are 407 delinquent accounts and above \$200.00 there are 105 accounts and the remaining accounts are below the \$200.00 mark.

He explained that the 105 accounts, for the most part have not made any payments since March and some of them have made a partial payment but the 105 accounts do have multiple months behind. His department began sending door hangers blue notices and phone calls to those customers to try to collect some payments and also to see if staff can be of any assistance in directing them to private and non-profit organizations that could possible help them paying their utility bill.

**MOTION:** Council Member Gloria Torres/Council Member Africa Luna-Carrasco to approve and adopt Resolution No. 2138 as presented. Motion passed unanimously.

The vote was as follows:

Mayor Gerardo Sanchez	Aye
Vice Mayor Maria Cecilia Cruz	Aye
Council Member Mario Buchanan Jr.	Aye
Council Member Africa Luna-Carrasco	Aye
Council Member Matias Rosales	Aye
Council Member Gloria Torres	Aye

## 7. SUMMARY OF CURRENT EVENTS

Mayor Gerardo Sanchez reported that the corona virus number of cases have remained stable, number of positives have been declining and thanked the community for wearing a mask. He added that the mask has been a big factor in the reduction of corona virus cases as well as maintaining the social distance recommendations.

Mr. Jose Guzman, Director of Planning & Zoning, reported the census response rate is currently at 39.4%, he encouraged residents to complete their questionnaire, only 36 days remain for the deadline to submit their responses. He also reminded everyone about the drive-up event to assist residents fill out their census which will take place at the Cesar Chavez Cultural Center. Also, staff is taking appointments to help residents fill out their census at City Hall outside the parking lot, or if they do not have transportation, staff can drive to their homes and help them fill it out. There is a promotional truck driving throughout the city promoting the cesnsus, which can be stopped to help them as well. Staff is also participating with the different schools in the city during their lunch distribution and giving out flyers with census information.

Mayor Gerardo Sanchez emphasized on the importance of responding the census questionnaire and if people do not participate, community funds will be lost from the federal government. The state is at 62% census participation.

Mr. Tade De La Hoya, City Manager, reported that the cities and town in Yuma County challenged their employees to fill out their census and the Town of Wellton won that challenge. He congratulated Mr. Guzman for filing the the grant report to to the NLC and for the city obtaining those funds in the amount of \$25,000.00. This money will help the city get to the 53.8% participation the city had in 2010 as the current response rate is 39.4%. He added that the Arizona Cares Act provided the city \$3.5 million based on the count from 2010.

Ms. Francia Alonso, Assistant to the City Council/PIO, reported staff has had communication with businesses and nine (9) confirmed that they were going to be participating in the challenge. They will make sure their employees were counted and help promote the census to their customers. Also, staff has reached out to state representatives and Senator Lisa Otondo and videos are on the way that will promote the census on the social media.

## 8. ADJOURNMENT

**MOTION**: Council Member Gloria Torres/Council Member Mario Buchanan Jr. to adjourn the Regular Council meeting at approximately 8:08 p.m. Motion passed unanimously.

The vote was as follows:

Mayor Gerardo Sanchez	Aye
Vice Mayor Maria Cecilia Cruz	Aye
Council Member Mario Buchanan Jr.	Aye
Council Member Africa Luna-Carrasco	Aye
Council Member Matias Rosales	Aye
Council Member Gloria Torres	Aye

**APPROVED:**

---

Gerardo Sanchez, Mayor

**ATTEST:**

---

Sonia Cornelio, City Clerk

**CERTIFICATION**

I hereby certify that the foregoing minutes are a true and correct copy of the minutes of the Regular City Council meeting of the City Council of the City of San Luis, Arizona, held on August 26, 2020. I further certify that the meeting was duly called and held and that a quorum was present.

---

Sonia Cornelio, City Clerk



## AGENDA ITEM REVIEW FORM

### Regular City Council Meeting

5. B.

Meeting Date: 09/23/2020

---

#### Summary

**DISBURSEMENTS FROM AUGUST 29, 2020 THROUGH SEPTEMBER 11, 2020**

**Total Disbursements \$761,474.16**

(Seven Hundred Sixty-One Thousand, Four Hundred Seventy-Four Dollars and Sixteen Cents)

---

#### Attachments

Disbursements

---



# City of San Luis

Finance Department

## COUNCIL MEETING SEPTEMBER 23, 2020 Disbursement Report from 8/29/2020 to 9/11/2020

<u>Bank Accounts</u>	<u>Check Date</u>	<u>Amount</u>	<u>Schedule</u>
Payroll Check Account	9/1/2020	\$ 340,768.30	Schedule A
Payroll Check Account	9/3/2020	\$ 4,526.08	Schedule B
Accounts Payable Check Account	9/3/2020	\$ 171,124.81	Schedule C
Accounts Payable Check Account	9/10/2020	\$ 245,054.97	Schedule D

**Total Disbursements:        \$ 761,474.16**

Please contact Ms. Monica Castro prior to the meeting if additional information is needed.

Prepared by Angelica V. Castro: *Angelica V. Castro*

**RECEIVED**

Verified by Director of Finance: *[Signature]*

**SEP 16 2020**

For Council approval on: \_\_\_\_\_

**Mayor:** \_\_\_\_\_

**Council:** \_\_\_\_\_

\_\_\_\_\_

\_\_\_\_\_

\_\_\_\_\_

\_\_\_\_\_

\_\_\_\_\_

**Office of the City Clerk**  
City of San Luis, Arizona



Schedule A

# Pay Day Register

Pay Date Range 08/15/20 - 08/28/20

Pay Batch 202018

TRANSWESTERN MEXICAN	96.76
U.S. MEX DENTAL - EE &	615.90
U.S. MEX DENTAL - EE &	123.18
UNITED WAY	14.00
US & MEX DENTAL= FAMILY	666.12
US & MEX HEALTH = C	5,124.24
US & MEX HEALTH = FAMILY	6,749.94
US & MEX HEALTH = SP	996.38
VSP - VISION FAMILY	687.94
Net	<u>\$340,768.30</u> ✓

		Gross Base
.00	Workers' Comp	
.00	ANIMAL CONTROL OFFICERS	59.92 2,663.12
.00	ATTORNEY- ALL & CLERICAL-	70.81 32,190.36
.00	AUTO SERVICE/ REPAIR	253.77 9,096.00
.00	BUILDING- NOC OPER BY	1,055.38 29,153.86
.00	BUS COMPANY AND DRIVERS	152.66 2,765.60
.00	CLERICAL OFFICE/ LIBRARY/	262.23 109,262.93
.00	Electrician	59.11 1,882.40
.00	FIREFIGHTERS & DRIVERS	4,824.38 110,145.03
	GARBAGE/ ASH/ REFUSE	280.10 4,481.60
	MUNICIPAL/ TOWN/	89.73 5,127.20
	PARKS- NOC ALL EMPLOYEES	533.23 17,200.85
	POLICE OFFICERS	4,435.52 101,267.12
	RECREATION- ALL EMPLOYEES/	223.09 16,283.61
	SEWAGE DISPOSAL/ PLANT	573.42 16,669.68
	Street or Road Construction	1,918.23 23,888.02
	WATERWORKS OPERATIONS	601.40 17,330.89
	Total	<u>\$15,392.98</u>

Direct Deposits	Amount
1st Bank Yuma	27,786.10
ACADEMY BANK	2,095.03
Bank of America	1,150.00
Bankcorp	150.00
BBVA COMPASS	988.88
Charles Sch	200.00
Chase Bank	164,774.78
CHASE BANK CA	963.52
chase centro	1,127.30
Federal Credit Union	34,912.75
FF CREDIT UNION	1,898.46
FIREFIGHTER FIRST CREDIT UNION	4,886.66
GREEN DOT BANK	359.45
National Bank	2,468.08
Navy Federal	19,791.49
NetSpend Corporation DD	120.00
NORTH ISLAND CREDIT UNION	647.25
Sunbank	1,270.60
USAA FEDERAL SAVING	1,773.56
WASHINGTON FEDERAL	932.60
Wells Fargo	67,661.34
WELLS FARGO BANK PP	864.28

Prepared by:  
Deborah Luna

Date:

CC Costes



Schedule B

# Pay Day Register

Pay Date Range 09/01/20 - 09/30/20

Pay Batch 202009M

Pay Batch 202009M Total  
Employees in Pay Batch 7  
Female Employees in Pay Batch 3

Hours Description	Hours	Gross	Withholdings and Deductions	Gross Base	Benefits	Gross Base
102 - SALARY	.0000	7,550.00	Gross	7,750.00	Dental Council	257.36
806 - TELEPHONE STIPEND	.0000	200.00	Imputed Income		EODCRS - COUNCIL	108.00
Total	0.0000	\$7,750.00	FEDERAL TAX WITHHOLDING	115.13	EODCRS - DISABILITY	2.26
			SOCIAL SECURITY TAX	480.50	EODCRS/EORP LEGACY RATE	997.74
			MEDICARE	112.36	Health Council	6,358.99
			STATE WITHHOLDING	154.06	Retirement Council EORP	3,532.23
			Council Retirement EORP	588.50	Vision Council	79.03
			Dental Council	143.51	Total	\$11,335.61
			EODCRS - COUNCIL	144.00	Workers' Comp	
			EODCRS - DISABILITY	2.26	MUNICIPAL/ TOWN/	135.65
			GARNISHMENT	221.11	Total	\$135.65
			Medical Council	1,155.61	Direct Deposits	
			MISCELLANEOUS	55.00	1st Bank Yuma	729.54
			Vision Council	51.88	Chase Bank	688.14
			Net	\$4,526.08	Federal Credit Union	939.74
					REALTORS FED CRED UNION	22.55
					Sunbank	919.47
					WASHINGTON FEDERAL	797.18
					Wells Fargo	429.46
					Total	\$4,526.08
					Check	\$0.00

Prepared by:

Debora Luna

Date:

Approved by

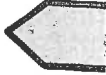

Schedule C

City of San Luis

# Payment Register

From Payment Date: 8/31/2020 - To Payment Date: 9/3/2020

Number	Date	Status	Void Reason	Reconciled/ Voided Date	Source	Payee Name	Transaction Amount	Reconciled Amount	Difference
95284	09/03/2020	Open			Accounts Payable	QUINONEZ, FRANCISCO	\$310.00		
95285	09/03/2020	Open			Accounts Payable	RODRIGUEZ, DANIEL	\$700.00		
95286	09/03/2020	Open			Accounts Payable	SAN DIEGO POLICE EQUIPMENT CO.	\$2,296.28		
95287	09/03/2020	Open			Accounts Payable	SKAGGS COMPANIES, INC	\$1,032.84		
95288	09/03/2020	Open			Accounts Payable	SOUTH YUMA COUNTY LANDFILL	\$14,726.64		
95289	09/03/2020	Open			Accounts Payable	SOUTHERN TIRE MART LLC	\$3,257.93		
95290	09/03/2020	Open			Accounts Payable	SOUTHWEST TURF SUPPLY	\$4,070.87		
95291	09/03/2020	Open			Accounts Payable	SPECIALTY SEWING SENTER, INC.	\$275.00		
95292	09/03/2020	Open			Accounts Payable	THE ROACH PEST CONTROL	\$140.00		
95293	09/03/2020	Open			Accounts Payable	THE WINDOOR SHOP	\$148.35		
95294	09/03/2020	Open			Accounts Payable	TNEMEC COMPANY INC	\$187.85		
95295	09/03/2020	Open			Accounts Payable	VCA ANIMAL HOSPITALS, INC.	\$1,215.63		
95296	09/03/2020	Open			Accounts Payable	YUMA PRINTING & GRAPHIC DEPT.	\$294.53		
95297	09/03/2020	Open			Accounts Payable	YUMA TRUCK PARTS	\$28.09		
95298	09/03/2020	Open			Accounts Payable	CORREA, CARLOS	\$100.00		
95299	09/03/2020	Open			Accounts Payable	INTERNAL REVENUE SERVICE	\$221.11		
95300	09/03/2020	Open			Accounts Payable	MACHADO, IVAN & AIXIA GUTIERREZ	\$1,000.00		

Type Check Totals:  
1BYPAYABLE - 1st BY Accounts Payable Totals

55 Transactions

\$171,124.81

Checks	Status	Count	Transaction Amount	Reconciled Amount
	Open	55	\$171,124.81	\$0.00
	Reconciled	0	\$0.00	\$0.00
	Voided	0	\$0.00	\$0.00
	Stopped	0	\$0.00	\$0.00
	<b>Total</b>	<b>55</b>	<b>\$171,124.81</b>	<b>\$0.00</b>

All	Status	Count	Transaction Amount	Reconciled Amount
	Open	55	\$171,124.81	\$0.00
	Reconciled	0	\$0.00	\$0.00
	Voided	0	\$0.00	\$0.00
	Stopped	0	\$0.00	\$0.00
	<b>Total</b>	<b>55</b>	<b>\$171,124.81</b>	<b>\$0.00</b>

Grand Totals:

Checks	Status	Count	Transaction Amount	Reconciled Amount
	Open	55	\$171,124.81	\$0.00
	Reconciled	0	\$0.00	\$0.00
	Voided	0	\$0.00	\$0.00
	Stopped	0	\$0.00	\$0.00
	<b>Total</b>	<b>55</b>	<b>\$171,124.81</b>	<b>\$0.00</b>

All	Status	Count	Transaction Amount	Reconciled Amount
	Open	55	\$171,124.81	\$0.00
	Reconciled	0	\$0.00	\$0.00
	Voided	0	\$0.00	\$0.00
	Stopped	0	\$0.00	\$0.00
	<b>Total</b>	<b>55</b>	<b>\$171,124.81</b>	<b>\$0.00</b>

Prepared By:  
Maggie Dominguez  
Date: 9/03/20.

# Payment Register

From Payment Date: 8/31/2020 - To Payment Date: 9/3/2020

Number	Date	Status	Void Reason	Reconciled/ Voided Date	Source	Payee Name	Transaction Amount	Reconciled Amount	Difference
1BYPAYABLE - 1st BY Accounts Payable									
Check									
95246	09/03/2020	Open			Accounts Payable	BALSINO, PETER, M	\$6.85		
95247	09/03/2020	Open			Accounts Payable	CHARGO PA, GURSTEL	\$26.95		
95248	09/03/2020	Open			Accounts Payable	FOP/ALC	\$405.00		
95249	09/03/2020	Open			Accounts Payable	INTERNAL REVENUE SERVICE	\$100.00		
95250	09/03/2020	Open			Accounts Payable	SAN LUIS POLICE OFFICERS ASSOC	\$375.00		
95251	09/03/2020	Open			Accounts Payable	SUPPORT PAYMENT CLEARINGHOUSE	\$3,463.45		
95252	09/03/2020	Open			Accounts Payable	UNITED WAY OF YUMA COUNTY INC.	\$14.00		
95253	09/03/2020	Open			Accounts Payable	UNITED YUMA FIRE FIGHTERS ASSOC	\$92.50		
95254	09/03/2020	Open			Accounts Payable	UNITED YUMA FIRE FIGHTERS- IAFF	\$1,000.00		
95255	09/03/2020	Open			Accounts Payable	TYLER TECHNOLOGIES, INC.	\$104,744.99		
95256	09/03/2020	Open			Accounts Payable	A & H ELECTRIC	\$635.00		
95257	09/03/2020	Open			Accounts Payable	ALDAMA, EMMANUEL	\$150.00		
95258	09/03/2020	Open			Accounts Payable	ALDAMA, EMMANUEL	\$268.00		
95259	09/03/2020	Open			Accounts Payable	ALSCO, INC	\$991.79		
95260	09/03/2020	Open			Accounts Payable	ANGEL'S TOWING SERVICE/AUTO SALES	\$225.00		
95261	09/03/2020	Open			Accounts Payable	ARIZONA BRAKE & CLUTCH SUPPLY	\$547.24		
95262	09/03/2020	Open			Accounts Payable	ARIZONA SOUTHWEST UNIFORMS LLC	\$128.05		
95263	09/03/2020	Open			Accounts Payable	B&H PHOTO & ELECTRONICS CORP.	\$65.75		
95264	09/03/2020	Open			Accounts Payable	BILL ALEXANDER FORD	\$1,520.88		
95265	09/03/2020	Open			Accounts Payable	BINGHAM EQUIPMENT CO	\$134.46		
95266	09/03/2020	Open			Accounts Payable	BOUND TREE MEDICAL, LLC.	\$695.80		
95267	09/03/2020	Open			Accounts Payable	BTE BODY COMPANY INC	\$1,306.21		
95268	09/03/2020	Open			Accounts Payable	CABLE & WIRELESS TECHNOLOGIES, INC	\$819.00		
95269	09/03/2020	Open			Accounts Payable	CARDENAS, ERNESTO	\$150.00		
95270	09/03/2020	Open			Accounts Payable	CENTERLINE SUPPLY WEST	\$4,997.27		
95271	09/03/2020	Open			Accounts Payable	DESERT DOCUMENT SHREDDERS, LLC	\$140.00		
95272	09/03/2020	Open			Accounts Payable	DESERT WATER	\$61.43		
95273	09/03/2020	Open			Accounts Payable	FISHER CHEVROLET - PARTS	\$393.80		
95274	09/03/2020	Open			Accounts Payable	FISHER CHRYSLER	\$478.10		
95275	09/03/2020	Open			Accounts Payable	FRESH TERRA SERVICES LLC	\$2,775.00		
95276	09/03/2020	Open			Accounts Payable	GUEVARA, ALAN	\$268.00		
95277	09/03/2020	Open			Accounts Payable	KINGHOSE INDUSTRY LLC	\$1,005.16		
95278	09/03/2020	Open			Accounts Payable	MOTION INDUSTRIES, INC.	\$4,572.36		
95279	09/03/2020	Open			Accounts Payable	NAPA AUTO PARTS	\$6,396.18		
95280	09/03/2020	Open			Accounts Payable	O'REILLY AUTO PARTS	\$431.51		
95281	09/03/2020	Open			Accounts Payable	PEREZ, HAZIEL	\$150.00		
95282	09/03/2020	Open			Accounts Payable	PUBLIC SAFETY CENTER, INC	\$1,469.30		
95283	09/03/2020	Open			Accounts Payable	PURCELL TIRE CO.	\$115.66		

# Payment Register

From Payment Date: 9/7/2020 - To Payment Date: 9/10/2020

Number	Date	Status	Void Reason	Reconciled/ Voided Date	Source	Payee Name	Transaction Amount	Reconciled Amount	Difference
95413	09/10/2020	Open			Accounts Payable	PREPAID LEGAL SERVICES	\$112.60		
95414	09/10/2020	Open			Accounts Payable	STANDARD INSURANCE CO.	\$2,046.25		
95415	09/10/2020	Open			Accounts Payable	TRANSWESTERN INSURANCE ADMIN	\$193.50		
95416	09/10/2020	Open			Accounts Payable	VISION SERVICE PLAN OF ARIZONA	\$4,266.74		
95417	09/10/2020	Open			Accounts Payable	WRS GROUP, LTD.,	\$938.95		
Type Check Totals:									
1BYPAYABLE - 1st BY Accounts Payable Totals								\$245,054.97	

Type Check Totals:  
1BYPAYABLE - 1st BY Accounts Payable Totals

Checks	Status	Count	Transaction Amount	Reconciled Amount
	Open	117	\$245,054.97	\$0.00
	Reconciled	0	\$0.00	\$0.00
	Voided	0	\$0.00	\$0.00
	Stopped	0	\$0.00	\$0.00
	<b>Total</b>	<b>117</b>	<b>\$245,054.97</b>	<b>\$0.00</b>

All	Status	Count	Transaction Amount	Reconciled Amount
	Open	117	\$245,054.97	\$0.00
	Reconciled	0	\$0.00	\$0.00
	Voided	0	\$0.00	\$0.00
	Stopped	0	\$0.00	\$0.00
	<b>Total</b>	<b>117</b>	<b>\$245,054.97</b>	<b>\$0.00</b>

Grand Totals:

Checks	Status	Count	Transaction Amount	Reconciled Amount
	Open	117	\$245,054.97	\$0.00
	Reconciled	0	\$0.00	\$0.00
	Voided	0	\$0.00	\$0.00
	Stopped	0	\$0.00	\$0.00
	<b>Total</b>	<b>117</b>	<b>\$245,054.97</b>	<b>\$0.00</b>

All	Status	Count	Transaction Amount	Reconciled Amount
	Open	117	\$245,054.97	\$0.00
	Reconciled	0	\$0.00	\$0.00
	Voided	0	\$0.00	\$0.00
	Stopped	0	\$0.00	\$0.00
	<b>Total</b>	<b>117</b>	<b>\$245,054.97</b>	<b>\$0.00</b>

Prepared By:  
*Maggie Dominguez*  
Date: *Maggie S.*  
*9/10/2020*

# Payment Register

From Payment Date: 9/7/2020 - To Payment Date: 9/10/2020

Number	Date	Status	Void Reason	Reconciled/ Voided Date	Source	Payee Name	Transaction Amount	Reconciled Amount	Difference
1BYPAYABLE - 1st BY Accounts Payable									
Check									
95301	09/10/2020	Open			Accounts Payable	HERNANDEZ, JERRY	\$2,400.00		
95302	09/10/2020	Open			Utility Management Refund	ACOSTA GLORIA & FILIBERTO	\$149.50		
95303	09/10/2020	Open			Utility Management Refund	ALVAREZ, LUIS	\$160.82		
95304	09/10/2020	Open			Utility Management Refund	COMITE DE BIENESTAR INC GRP #75	\$0.62		
95305	09/10/2020	Open			Utility Management Refund	COSIO, ISIDRO & ELVA RINCON	\$188.69		
95306	09/10/2020	Open			Utility Management Refund	DE LA CRUZ, ALMA	\$70.00		
95307	09/10/2020	Open			Utility Management Refund	FIGUEROA, JUAN R & MARGARITA	\$179.86		
95308	09/10/2020	Open			Utility Management Refund	GARCIA, VERONICA, E	\$85.60		
95309	09/10/2020	Open			Utility Management Refund	GRP #75 ARVIZU-SEPULVEDA, ANDRES	\$23.24		
95310	09/10/2020	Open			Utility Management Refund	GRP #75 ESPARZA, ROSA	\$36.84		
95311	09/10/2020	Open			Utility Management Refund	HAMMOND, PEDRO	\$134.91		
95312	09/10/2020	Open			Utility Management Refund	HERNANDEZ, HERIBERTO & MARIA SAUCEDO	\$210.22		
95313	09/10/2020	Open			Utility Management Refund	JENAL ENGINEERING CORP C/O ALAN WESTERMEYER	\$747.72		
95314	09/10/2020	Open			Utility Management Refund	LOPEZ, VANESSA	\$132.87		
95315	09/10/2020	Open			Utility Management Refund	MUNOZ, JULIO, CESAR	\$118.28		
95316	09/10/2020	Open			Utility Management Refund	NAVARRETE, VICTOR & JESUS BUSTAMANTE	\$169.71		
95317	09/10/2020	Open			Utility Management Refund	NIEBLA, CARMEN	\$89.72		
95318	09/10/2020	Open			Utility Management Refund	RAMIREZ, JOSE , E	\$238.43		
95319	09/10/2020	Open			Utility Management Refund	RIEDEL CONSTRUCTION INC	\$14.77		
95320	09/10/2020	Open			Utility Management Refund	RIEDEL CONSTRUCTION INC	\$3.82		
95321	09/10/2020	Open			Utility Management Refund	RIEDEL CONSTRUCTION INC	\$1.83		
95322	09/10/2020	Open			Utility Management Refund	RIEDEL CONSTRUCTION INC	\$1.33		
95323	09/10/2020	Open			Utility Management Refund	ROSA P GOMEZ & JOSE M DIAZ	\$105.17		
95324	09/10/2020	Open			Utility Management Refund	SOLORIO , BEATRIZ ADRIANA	\$269.70		
95325	09/10/2020	Open			Utility Management Refund	VALENZUELA, ABRAHAM	\$2.82		

# Payment Register

From Payment Date: 9/7/2020 - To Payment Date: 9/10/2020

Number	Date	Status	Void Reason	Reconciled/ Voided Date	Source	Payee Name	Transaction Amount	Reconciled Amount	Difference
95326	09/10/2020	Open			Utility Management Refund	VALENZUELA, KARLA, S	\$194.01		
95327	09/10/2020	Open			Utility Management Refund	VILLALON, ANDRES & NANCY	\$160.54		
95328	09/10/2020	Open			Accounts Payable	PARASOL ENTERPRISES, LLC	\$1,282.00		
95329	09/10/2020	Open			Accounts Payable	LIBERTY MOTORSPORTS	\$1,245.43		
95330	09/10/2020	Open			Accounts Payable	LUNA, CYNTHIA	\$50.00		
95331	09/10/2020	Open			Accounts Payable	MACHADO, IVAN & AIXIA GUTIERREZ	\$1,000.00		
95332	09/10/2020	Open			Accounts Payable	RODRIGUEZ, DANIEL	\$1,700.00		
95333	09/10/2020	Open			Accounts Payable	YUMA COUNTY ARTS AND CULTURAL GROUP	\$5,000.00		
95334	09/10/2020	Open			Accounts Payable	ALSCO, INC	\$124.70		
95335	09/10/2020	Open			Accounts Payable	AMBERLY'S PLACE	\$3,500.00		
95336	09/10/2020	Open			Accounts Payable	AMERICAN BUSINESS FORMS INC.	\$4,165.61		
95337	09/10/2020	Open			Accounts Payable	APS/CLAIM #414-1352-AH	\$50.00		
95338	09/10/2020	Open			Accounts Payable	ARCHIVESOCIAL INC.	\$4,788.00		
95339	09/10/2020	Open			Accounts Payable	ARIZONA STATE TREASURER	\$25,995.88		
95340	09/10/2020	Open			Accounts Payable	ARIZONA SUPREME COURT	\$250.00		
95341	09/10/2020	Open			Accounts Payable	ARIZONA SUPREME COURT	\$9,481.37		
95342	09/10/2020	Open			Accounts Payable	ARVIZU, EDUARDO	\$400.00		
95343	09/10/2020	Open			Accounts Payable	ARVIZU VILLAR, GLORIA	\$50.00		
95344	09/10/2020	Open			Accounts Payable	BASIC BENEFITS LLC	\$280.00		
95345	09/10/2020	Open			Accounts Payable	BECKER, PAUL	\$200.00		
95346	09/10/2020	Open			Accounts Payable	BERKELEY RESEARCH GROUP LLC	\$36,410.50		
95347	09/10/2020	Open			Accounts Payable	BINGHAM AUTO & TRUCK PARTS	\$15.77		
95348	09/10/2020	Open			Accounts Payable	BINGHAM EQUIPMENT CO	\$1,264.89		
95349	09/10/2020	Open			Accounts Payable	BLT ASPHALT LLC	\$7,017.31		
95350	09/10/2020	Open			Accounts Payable	BLT READY MIX CONCRETE LLC	\$2,131.20		
95351	09/10/2020	Open			Accounts Payable	BOTACH INC	\$115.15		
95352	09/10/2020	Open			Accounts Payable	BOUND TREE MEDICAL, LLC.	\$12,077.62		
95353	09/10/2020	Open			Accounts Payable	CDWG	\$2,643.08		
95354	09/10/2020	Open			Accounts Payable	CITY OF SOMERTON	\$15,696.58		
95355	09/10/2020	Open			Accounts Payable	CORDOVA LAW, PLC	\$2,400.00		
95356	09/10/2020	Open			Accounts Payable	DESERT WATER	\$182.65		
95357	09/10/2020	Open			Accounts Payable	DIAMONDBACK POLICE SUPPLY, INC.	\$151.04		
95358	09/10/2020	Open			Accounts Payable	DIAZ, JOSE, M	\$32.60		
95359	09/10/2020	Open			Accounts Payable	ESTRADA, LETICIA	\$50.00		
95360	09/10/2020	Open			Accounts Payable	EXCEPTIONAL WATER SYSTEMS, LLC	\$394.91		
95361	09/10/2020	Open			Accounts Payable	FISHER CHEVROLET - PARTS	\$241.13		
95362	09/10/2020	Open			Accounts Payable	G&T LOCKSMITH AND SAFE CO.	\$80.00		
95363	09/10/2020	Open			Accounts Payable	GALLS, AN ARAMARK CO., LLC	\$838.65		
95364	09/10/2020	Open			Accounts Payable	GILA ELECTRONIC	\$975.71		
95365	09/10/2020	Open			Accounts Payable	GOMEZ-DOMINGUEZ, FRANCISCO	\$612.62		
95366	09/10/2020	Open			Accounts Payable	HUGHES FIRE EQUIPMENT, INC.	\$414.26		
95367	09/10/2020	Open			Accounts Payable	IRON MOUNTAIN INC	\$39.74		
95368	09/10/2020	Open			Accounts Payable	LAWSON PRODUCTS INC.	\$2,509.32		
95369	09/10/2020	Open			Accounts Payable	LONGORIA PONCE, RICARDO	\$1,000.00		

# Payment Register

From Payment Date: 9/7/2020 - To Payment Date: 9/10/2020

Number	Date	Status	Void Reason	Reconciled/ Voided Date	Source	Payee Name	Transaction Amount	Reconciled Amount	Difference
95370	09/10/2020	Open			Accounts Payable	LOOMIS	\$924.77		
95371	09/10/2020	Open			Accounts Payable	LOPEZ LARA, JUAN, ANGEL	\$500.00		
95372	09/10/2020	Open			Accounts Payable	MCNEECE BROS. OIL COMPANY, INC	\$22,133.61		
95373	09/10/2020	Open			Accounts Payable	METRO FIRE EQUIPMENT INC	\$897.10		
95374	09/10/2020	Open			Accounts Payable	MEZA, JOSE	\$23.00		
95375	09/10/2020	Open			Accounts Payable	MGM INTERNET SOLUTIONS, INC	\$53.00		
95376	09/10/2020	Open			Accounts Payable	MORALES VILLA, ELEAZAR	\$47.28		
95377	09/10/2020	Open			Accounts Payable	MOTION INDUSTRIES, INC.	\$235.75		
95378	09/10/2020	Open			Accounts Payable	MUNICIPAL EMERGENCY SERVICES, INC	\$1,863.72		
95379	09/10/2020	Open			Accounts Payable	NAVARRO, CAROLINE	\$100.00		
95380	09/10/2020	Open			Accounts Payable	NORWOOD EQUIPMENT INC.	\$531.36		
95381	09/10/2020	Open			Accounts Payable	OFFICE DEPOT	\$2,838.34		
95382	09/10/2020	Open			Accounts Payable	ORTEGA, LUZ	\$75.00		
95383	09/10/2020	Open			Accounts Payable	PINNACLE MEDICAL GROUP AZ P.C	\$35.00		
95384	09/10/2020	Open			Accounts Payable	PRECISION ELECTRIC CO. INC.	\$4,442.00		
95385	09/10/2020	Open			Accounts Payable	RALPH VELEZ CONSULTING SERVICES	\$8,125.00		
95386	09/10/2020	Open			Accounts Payable	RAMIREZ ADVISORS INTER- NATIONAL,LLC	\$9,166.66		
95387	09/10/2020	Open			Accounts Payable	RUSH TRUCK CENTER	\$4,626.61		
95388	09/10/2020	Open			Accounts Payable	SAM'S CLUB	\$1,014.83		
95389	09/10/2020	Open			Accounts Payable	SAN LUIS AIR CONDITIONING LLC	\$285.00		
95390	09/10/2020	Open			Accounts Payable	SHUCK DRILLING COMPANY LLC	\$3,412.66		
95391	09/10/2020	Open			Accounts Payable	SOUTHWEST ENTRANCES, INC	\$355.00		
95392	09/10/2020	Open			Accounts Payable	SURVEY MONKEY, INC	\$372.00		
95393	09/10/2020	Open			Accounts Payable	THE WINDOOR SHOP	\$592.85		
95394	09/10/2020	Open			Accounts Payable	THOMSON WEST PUBLISHING CO.	\$335.66		
95395	09/10/2020	Open			Accounts Payable	TINOCO, JOSE, A	\$500.00		
95396	09/10/2020	Open			Accounts Payable	TORRES, ALEJANDRA , S	\$2,086.44		
95397	09/10/2020	Open			Accounts Payable	VAPEX ENVIRONMENTAL TECHNOLOGIES, LLC	\$4,028.67		
95398	09/10/2020	Open			Accounts Payable	WBA INC	\$471.62		
95399	09/10/2020	Open			Accounts Payable	YBARRA, TRINIDAD	\$50.00		
95400	09/10/2020	Open			Accounts Payable	YUMA COUNTY ADULT DETENTION CENTER	\$49.16		
95401	09/10/2020	Open			Accounts Payable	YUMA COUNTY HUMANE SOCIETY	\$8,333.34		
95402	09/10/2020	Open			Accounts Payable	YUMA COUNTY TREASURER	\$97.75		
95403	09/10/2020	Open			Accounts Payable	YUMA COUNTY WATER USERS	\$20.00		
95404	09/10/2020	Open			Accounts Payable	YUMA NURSERY SUPPLY	\$234.28		
95405	09/10/2020	Open			Accounts Payable	YUMA PRINTING & GRAPHIC DEPT.	\$257.18		
95406	09/10/2020	Open			Accounts Payable	YUMA REGIONAL MEDICAL CENTER	\$2,455.09		
95407	09/10/2020	Open			Accounts Payable	YUMA SUN INC	\$1,764.04		
95408	09/10/2020	Open			Accounts Payable	DUENAS, RAMON, R	\$150.00		
95409	09/10/2020	Open			Accounts Payable	ENTERPRISE FM TRUST	\$763.76		
95410	09/10/2020	Open			Accounts Payable	MANHATTANLIFE ASSURANCE CO	\$291.54		
95411	09/10/2020	Open			Accounts Payable	MASSMUTUAL FINANCIAL GROUP	\$40.00		
95412	09/10/2020	Open			Accounts Payable	NEW YORK LIFE INSURANCE CO.	\$169.12		



## AGENDA ITEM REVIEW FORM

### Regular City Council Meeting

6. A.

**Meeting Date:** 09/23/2020

**Department Head:** Nohemy Echavarria, Magistrate, Court

**Submitted By:** Nohemy Echavarria, Magistrate, Court

**Action Requested:** Motion  
Resolution

---

#### ITEM:

Discussion and possible action on any and all matters regarding Resolution No. 2140. A resolution of the Mayor and Council of the City of San Luis, Arizona approving an Addendum to the Intergovernmental Agreement (IGA) between the City of San Luis, Arizona and Yuma County for the purpose of providing mandatory field training. **(Nohemy Echavarria, Magistrate)**

#### SUMMARY:

The City of San Luis has previously entered into an IGA with Yuma County Superior Court and its justice courts to provide field training as mandated by the Arizona Supreme Court and the Administrative Office of the Courts. The City of San Luis has entered into this IGA for several years. This Addendum is with the Yuma Superior Court to provide training to the San Luis Municipal Court. Therefore, San Luis Municipal Court requests that City Council approve the Addendum in the amount of \$1,000.00.

#### RECOMMENDATION / SUGGESTED MOTION:

**I MOVE TO ADOPT AND APPROVE RESOLUTION NO. 2140 AS PRESENTED.**

N/A

---

#### Fiscal Impact

<b>IS THERE FISCAL IMPACT ASSOCIATED WITH THIS ITEM:</b>	Yes
<b>CITY/STATE/FEDERAL FUNDS:</b>	City
<b>TOTAL:</b>	\$1,000.00
<b>BUDGETED AMOUNT:</b>	\$1,000.00
<b>AVAILABLE AMOUNT TO TRANSFER:</b>	0
<b>ACCT NAME &amp; GL#/REMAINING BALANCE BEFORE PURCHASE:</b>	100-160-80000 \$32,572
<b>FISCAL IMPACT STATEMENT (IF THIS IS A BUDGET TRANSFER, YOU MUST ATTACH THE BUDGET ADJUSTMENT FORM):</b>	
Total budget under 10-160-80000, contractual services for FY2020-2021.	

---

#### Attachments

Resolution No. 2140  
IGA Field Trainer

---



# Resolution

No. 2140

OFFICE OF THE  
MAYOR  
CITY OF SAN LUIS

A RESOLUTION OF THE MAYOR AND COUNCIL OF THE CITY OF SAN LUIS, ARIZONA APPROVING THE ADDENDUM TO THE INTERGOVERNMENTAL AGREEMENT (IGA) BETWEEN THE CITY OF SAN LUIS, ARIZONA AND YUMA COUNTY FOR THE PURPOSE OF PROVIDING MANDATORY FIELD TRAINING.

**WHEREAS**, the City of San Luis desires to exercise the option to extend a previous Intergovernmental Agreement with Yuma County for the provision of mandatory field training; and

**WHEREAS**, all parties to the Intergovernmental Agreement desire to exercise the option to extend said agreement;

**NOW THEREFORE BE IT RESOLVED**, by the Mayor and Council of the City of San Luis, State of Arizona, as follows:

**Section 1.** That the addendum to the Intergovernmental Agreement, as attached hereto as Exhibit "A", is hereby approved.

**Section 2.** That the appropriate City officials are hereby authorized and directed to enter into said agreement on behalf of the City and take any all actions as may be necessary to effectuate said agreement.

**PASSED AND ADOPTED** by the Mayor and Common Council of the City of San Luis, Arizona, this \_\_\_\_\_ day of \_\_\_\_\_, 2020.

\_\_\_\_\_  
Gerardo Sanchez, Mayor

ATTEST:

APPROVED AS TO FORM:

\_\_\_\_\_  
Sonia Cornelio, City Clerk

\_\_\_\_\_  
Kay Marion Macuil, City Attorney

ADDENDUM TO INTERGOVERNMENTAL AGREEMENT  
BETWEEN THE CITY OF SAN LUIS AND SUPERIOR  
COURT IN YUMA COUNTY

*Yuma County Field Trainer*

The original Intergovernmental Agreement was signed and dated on July 2016 and further approved by San Luis City Resolution No. 1149, Section 1. B. "Court's Option to Extend" provided for "five (1) one year periods, beginning on July 1, 2016..."

It is hereby agreed upon by the parties to exercise the option to extend said agreement for an additional (1) one year period beginning July 1, 2020 and terminating on June 30, 2021. The City shall pay the Court \$1000.00 for the period covered under this extension. All of the terms and conditions contained in the original intergovernmental agreement remain in full force and effect during the extended term.

IN WITNESS WHEREOF, the parties hereto have executed this addendum on the dates written below.

SUPERIOR COURT IN YUMA COUNTY

\_\_\_\_\_  
Hon. David M. Haws  
Presiding Judge

\_\_\_\_\_  
Date

8-21-2020

THE CITY OF SAN LUIS

\_\_\_\_\_  
Tadeo de la Hoya  
San Luis City Administrator

\_\_\_\_\_  
Date

ATTESTED:

\_\_\_\_\_  
Sonia Cornelio  
San Luis City Clerk

\_\_\_\_\_  
Date

APPROVED AS TO FORM:

\_\_\_\_\_  
Kay M. Macuil  
San Luis City Attorney

\_\_\_\_\_  
Date

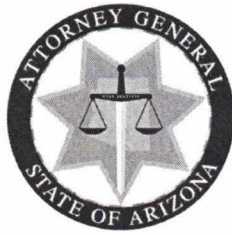

OFFICE OF THE ARIZONA ATTORNEY GENERAL

MARK BRNOVICH  
ATTORNEY GENERAL

STATE GOVERNMENT DIVISION  
AGENCY COUNSEL SECTION

INTERGOVERNMENTAL AGREEMENT DETERMINATION

Attorney General Contract No.                     KR20-1019                     which is an Agreement between public agencies, has been reviewed pursuant to A.R.S. § 11-952 by the undersigned Assistant Attorney General, who has determined that it is in the proper form and is within the powers granted under the laws of the State of Arizona to those Parties to the Agreement represented by the Attorney General.

Dated this 11<sup>th</sup> day of August, 2020

MARK BRNOVICH  
ATTORNEY GENERAL

Eryn M. Carlybor  
Assistant Attorney General  
SCA



## AGENDA ITEM REVIEW FORM

### Regular City Council Meeting

6. B.

**Meeting Date:** 09/23/2020

**Department Head:** Nohemy Echavarria, Magistrate, Court

**Submitted By:** Nohemy Echavarria, Magistrate, Court

**Action Requested:** Motion  
Resolution

---

#### ITEM:

Discussion and possible action on any and all matters regarding Resolution No. 2141. A resolution of the Mayor and City Council of the City of San Luis, Arizona approving the addendum to the Intergovernmental Agreement (IGA) between the City of San Luis, Arizona and Yuma County for the purpose of providing mandatory weekend and holiday court services for San Luis Municipal Court.

**(Nohemy Echavarria, Magistrate)**

#### SUMMARY:

The City of San Luis has previously entered into an Intergovernmental Agreement (IGA) with Yuma County and its justice courts to provide for weekend and holiday coverage for San Luis Municipal Court. Under Rule 4.1 of the Arizona Rules of Criminal Procedure, a person who is arrested must be brought before a judge within 24 hours, even on weekends and holidays. Under this IGA, Yuma County provides a judge and other necessary personnel and materials to conduct hearings on weekends and holidays to cover all the local courts. The City of San Luis has entered into this IGA for several years, and under the contract, the city agrees to pay Yuma County based on the caseload calculated during the fiscal year. Cost varies from year-to-year but has always been under \$1,500.00, with the amount in 2018 and 2019 being \$945.00. Staff is requesting that City Council approve the Addendum in the amount of \$601.00.

#### RECOMMENDATION / SUGGESTED MOTION:

**I MOVE TO ADOPT AND APPROVE RESOLUTION NO. 2141 AS PRESENTED.**

N/A

---

#### Fiscal Impact

<b>IS THERE FISCAL IMPACT ASSOCIATED WITH THIS ITEM:</b>	Yes
<b>CITY/STATE/FEDERAL FUNDS:</b>	City
<b>TOTAL:</b>	\$601.00
<b>BUDGETED AMOUNT:</b>	\$601.00
<b>AVAILABLE AMOUNT TO TRANSFER:</b>	0
<b>ACCT NAME &amp; GL#/REMAINING BALANCE BEFORE PURCHASE:</b>	100-160-80000 \$32,572
<b>FISCAL IMPACT STATEMENT (IF THIS IS A BUDGET TRANSFER, YOU MUST ATTACH THE BUDGET ADJUSTMENT FORM):</b>	

Total budget under 100-160-80000, contractual services for FY 2020-2021.

---

## Attachments

Resolution No. 2141  
Addendum to the IGA

---



# Resolution

No. 2141

OFFICE OF THE  
MAYOR  
CITY OF SAN LUIS

A RESOLUTION OF THE MAYOR AND COUNCIL OF THE CITY OF SAN LUIS, ARIZONA APPROVING THE ADDENDUM TO THE INTERGOVERNMENTAL AGREEMENT (IGA) BETWEEN THE CITY OF SAN LUIS, ARIZONA AND YUMA COUNTY FOR THE PURPOSE OF PROVIDING MANDATORY WEEKEND AND HOLIDAY COURT SERVICES.

**WHEREAS**, the City of San Luis desires to exercise the option to extend a previous Intergovernmental Agreement with Yuma County for the provision of mandatory weekend and holiday court services; and

**WHEREAS**, all parties to the Intergovernmental Agreement desire to exercise the option to extend said agreement;

**NOW THEREFORE BE IT RESOLVED**, by the Mayor and Council of the City of San Luis, State of Arizona, as follows:

**Section 1.** That the addendum to the Intergovernmental Agreement, as attached hereto as Exhibit "A", is hereby approved.

**Section 2.** That the appropriate City officials are hereby authorized and directed to enter into said agreement on behalf of the City and take any all actions as may be necessary to effectuate said agreement.

**PASSED AND ADOPTED** by the Mayor and Common Council of the City of San Luis, Arizona, this \_\_\_\_\_ day of \_\_\_\_\_, 2020.

\_\_\_\_\_  
Gerardo Sanchez, Mayor

ATTEST:

APPROVED AS TO FORM:

\_\_\_\_\_  
Sonia Cornelio, City Clerk

\_\_\_\_\_  
Kay Marion Macuil, City Attorney

ADDENDUM TO INTERGOVERNMENTAL AGREEMENT  
BETWEEN  
YUMA COUNTY AND CITY OF SAN LUIS  
FOR  
Weekend and Holiday Municipal Court Coverage

Pursuant to number 2, TERM: of the original intergovernmental agreement dated July 1, 2016 and recorded with the Yuma County Recorder for the provision of weekend and holiday Municipal Court coverage, it is hereby agreed upon by the parties to exercise the option to extend said agreement for an additional one year period beginning July 1, 2019 and terminating on June 30, 2020. The City shall pay the County \$601.00 for the period covered under the original intergovernmental agreement July 1, 2019 through June 30, 2020. All of the terms and conditions contained in the original intergovernmental agreement remain in full force and effect during the extended term.

IN WITNESS WHEREOF, the parties hereto have executed this addendum on the dates written below.

YUMA COUNTY:

\_\_\_\_\_  
Tony Reyes, Chairman  
Yuma County Board of Supervisors

\_\_\_\_\_  
Date

Approved as to form and within the powers and authority granted under the laws of Arizona to Yuma County:

\_\_\_\_\_  
Jon R. Smith  
Yuma County Attorney

\_\_\_\_\_  
Date

City of San Luis:

\_\_\_\_\_  
Tadeo De La Hoya  
San Luis City Manager

\_\_\_\_\_  
Date

Attest:

\_\_\_\_\_  
Sonia Cornelio  
San Luis City Clerk

\_\_\_\_\_  
Date

Approved as to form:

\_\_\_\_\_  
Kay M. Macuil  
San Luis City Attorney

\_\_\_\_\_  
Date



# AGENDA ITEM REVIEW FORM

## Regular City Council Meeting

6. C.

**Meeting Date:** 09/23/2020

**Department Head:** Sonia Cornelio, City Clerk, City Clerk's Office

**Submitted By:** Sonia Cornelio, City Clerk, City Clerk's Office

**Action Requested:** Motion  
Resolution

### ITEM:

Discussion and possible action on any and all matters regarding Resolution No. 2142. A resolution of the Mayor and City Council of the City of San Luis, Arizona, ratifying and approving the creation of positions in the classified service of the city; amending the classification and service plan of the city; superseding any conflicting provisions of existing regulations or policies; providing for severability; and declaring an emergency. **(Kay Macuil, City Attorney)**

### SUMMARY:

The following positions were created under the authority of San Luis City Code § 31.20(5)(a) because they were determined to be necessary for the effective operation and administration of the affairs of the city. The paralegal position was a promotion of an existing legal secretary without adding personnel. The Executive Assistant and Government and Foreign Affairs Coordinator have been filled. The Records Management Specialist is yet to be filled. The classification and pay grades were approved by CPS HR Consulting, which is the agency that did the in-depth studies to update the classification plan the city has. Staff recommends approval and ratification of this resolution so that the positions may be formally included in the classification plan.

<u>Position</u> <u>Grade</u>	<u>Department</u>	<u>Pay</u>
1. Executive Assistant	Administration	209
2. Government and Foreign Affairs Coordinator	Administration	202
3. Paralegal	City Prosecutor	200
4. Records Management Specialist	City Clerk	200

### RECOMMENDATION / SUGGESTED MOTION:

**I MOVE TO APPROVE AND RATIFY RESOLUTION NO. 2142 AS PRESENTED AND DECLARE AN EMERGENCY.**

N/A

### Fiscal Impact

<b>IS THERE FISCAL IMPACT ASSOCIATED WITH THIS ITEM:</b>	YES
<b>CITY/STATE/FEDERAL FUNDS:</b>	CITY
<b>TOTAL:</b>	\$276,145.00
<b>BUDGETED AMOUNT:</b>	\$276,145.00
<b>AVAILABLE AMOUNT TO TRANSFER:</b>	N/A

**ACCT NAME & GL#/REMAINING BALANCE BEFORE PURCHASE:** XXX.XXX.50XXX See fiscal impact stmt

**FISCAL IMPACT STATEMENT (IF THIS IS A BUDGET TRANSFER, YOU MUST ATTACH THE BUDGET ADJUSTMENT FORM):**

Funds to cover for these positions were allocated for FY budget 2020-21. They will be paid from the salaries and benefits accounts for City Clerk, City Prosecutor and Administration Departments.

---

**Attachments**

Resolution No. 2142

---



# Resolution

OFFICE OF THE  
MAYOR  
CITY OF SAN LUIS

No. 2142

**A RESOLUTION OF THE MAYOR AND CITY COUNCIL OF THE CITY OF SAN LUIS, ARIZONA, RATIFYING AND APPROVING THE CREATION OF POSITIONS IN THE CLASSIFIED SERVICE OF THE CITY; AMENDING THE CLASSIFICATION AND SERVICE PLAN OF THE CITY; SUPERSEDING ANY CONFLICTING PROVISIONS OF EXISTING REGULATIONS OR POLICIES; PROVIDING FOR SEVERABILITY; AND DECLARING AN EMERGENCY.**

**WHEREAS**, the City Council has established the positions of classification and service plan of the City of San Luis;

**WHEREAS**, the City Council as part of the budget for the fiscal year 2019-2020 and 2020-2021 established and funded positions within said classification and service plan for those fiscal years;

**WHEREAS**, under San Luis City Code § 31.20(5)(a), new positions were created and appointed within the classified service during the fiscal year 2019-2020 and 2020-2021, and there is a desire to fill the new, recently-budgeted position in the City Clerk's office; and

**WHEREAS**, City Council desires to ratify and approve the decisions previously made, including authorizing the new position City Council budgeted for the 2020-2021 fiscal year in the City Clerk's Office;

**NOW THEREFORE BE IT RESOLVED** by the Mayor and City Council of the City of San Luis, Arizona, as follows:

**Section 1.** That the following positions, the job descriptions being on file in the Human Resources Department, with the respective salary ranges as created during fiscal years 2019-2020 or 2020-2021 are authorized, ratified and approved:

<u>Position</u>	<u>Department</u>	<u>Pay Grade</u>
1. Executive Assistant	Administration	209
2. Government and Foreign Affairs Coordinator	Administration	202
3. Paralegal	City Prosecutor	200
4. Records Management Specialist	City Clerk	200

**Section 2.** That the classification and service plan of the City of San Luis for fiscal years 2019-2020 and 2020-2021 are amended to reflect the addition of the positions and corresponding salary ranges for said positions, as stated in Section 1 above.

**Section 3.** In the event of a conflict between the provisions of this resolution and any other resolution, ordinance, regulation, or policy of the City of San Luis, the conflicting provisions are amended, superseded, and replaced, and the provisions of this resolution shall govern.

**Section 4.** If any section, subsection, sentence, clause, phrase, or portion of this resolution is for any reason held to be invalid or unconstitutional by the final decision of any court of competent jurisdiction, such decision shall not affect the validity of the remaining portions of this resolution.

**Section 5.** Whereas it is necessary for the preservation of the peace, health, safety, and welfare of the City of San Luis and for the further reason that the foregoing positions were created because they were determined to be necessary for the effective operation and administration of the affairs of the city, it is determined that the best interests of the city require the provisions of this resolution to go into immediate effect; therefore an emergency is hereby declared to exist, and this resolution shall become immediately operative and in force and effect from and after the posting of this resolution.

**PASSED AND ADOPTED** by the Mayor and Council of the City of San Luis, Arizona, this \_\_\_\_\_ day of September 2020.

\_\_\_\_\_  
Gerardo Sanchez, Mayor

**ATTEST:**

**APPROVED AS TO FORM:**

\_\_\_\_\_  
Sonia Cornelio, City Clerk

\_\_\_\_\_  
Kay Macuil, City Attorney



## AGENDA ITEM REVIEW FORM

### Regular City Council Meeting

6. D.

**Meeting Date:** 09/23/2020

**Department Head:** Kay Macuil, City Attorney, Attorney's Office

**Submitted By:** Kay Macuil, City Attorney, Attorney's Office

**Action Requested:** Motion  
Ordinance

---

### ITEM:

Discussion and possible action on any and all matters regarding Ordinance No. 401. An ordinance of the Mayor and City Council of the City of San Luis, Arizona, establishing the Department of Parks and Recreation as the authority for the management of trees in the City of San Luis and practices for the care of the trees and removal when in the health, safety and welfare interests of the residents; amending the San Luis City Code; repealing any conflicting provision; providing for severability; providing for penalties; and declaring an emergency. **(Lizandro Galaviz, Director of Parks and Recreation and Mary French-Jones, Grant Writer)**

- A. Action on Reading of Ordinance No. 401 by title only  
(City Clerk to read the ordinance by title only)
- B. Action and adoption of Ordinance No. 401

### SUMMARY:

Tree City U.S.A. Program and Ordinance No. 401

City staff is requesting consideration to become a Tree City U.S.A. community. The program creates an opportunity to celebrate the importance of an urban tree canopy and improve the vitality of city trees. Tree City U.S.A.'s program has been greening up cities and towns across America since 1976. The program provides a framework for the city to manage and expand our public trees' inventory.

In order to become a recognized Tree City U.S.A. community, the city must meet certain core standards of sound urban forestry management by maintaining a city department that part of their job maintains a focus on, having a community tree ordinance, spending at least \$2 per capita on urban forestry and celebrating Arbor Day.

Although becoming a Tree City U.S.A. community is a collective city departmental effort, staff is recommending that the Director of Parks and Recreation and associated staff be assigned to lead this effort. The Parks and Recreation Department budget meets the required per capita to grow and maintain the city's urban canopy. The department routinely facilitates the city's large events, and celebrating Arbor Day annually would be easily incorporated into the department's events list.

To create a local tree program will include the development of a strategic plan of counting/recording, designating planting areas, and implementing a tree nursery program in partnership with local agencies. This information will create a foundation to work towards becoming a certified tree city and building environmental awareness in our community.

Approving the Ordinance meets the requirements of the Tree City U.S.A. program, and it will be the first

step in implementing the program and seeking funds to help support the program.

**RECOMMENDATION / SUGGESTED MOTION:**

**A. I MOVE TO APPROVE READING OF ORDINANCE NO. 401 BY TITLE ONLY**  
(City Clerk to read Ordinance No. 401 by title only)

**B. I MOVE TO APPROVE AND ADOPT ORDINANCE NO. 401 AND DECLARE AN EMERGENCY**

N/A

---

**Fiscal Impact**

**IS THERE FISCAL IMPACT ASSOCIATED WITH THIS ITEM:** No

**CITY/STATE/FEDERAL FUNDS:** N/A

**TOTAL:** N/A

**BUDGETED AMOUNT:** N/A

**AVAILABLE AMOUNT TO TRANSFER:** N/A

**ACCT NAME & GL#/REMAINING BALANCE BEFORE PURCHASE:** N/A

**FISCAL IMPACT STATEMENT (IF THIS IS A BUDGET TRANSFER, YOU MUST ATTACH THE BUDGET ADJUSTMENT FORM):**

The Department of Parks and Recreation is currently the Department charged with the maintenance of city trees. This ordinance codifies those responsibilities and there is no additional cost to the Department. However, having this ordinance that spells out the management of the trees may lead to grant revenue for the city.

---

**Attachments**

Ordinance No. 401

---



# *Ordinance*

OFFICE OF THE  
MAYOR  
CITY OF SAN LUIS

No. 401

AN ORDINANCE OF THE MAYOR AND CITY COUNCIL OF THE CITY OF SAN LUIS, ARIZONA, ESTABLISHING THE DEPARTMENT OF PARKS AND RECREATION AS THE AUTHORITY FOR THE MANAGEMENT OF TREES IN THE CITY OF SAN LUIS AND PRACTICES FOR THE CARE OF THE TREES AND REMOVAL WHEN IN THE HEALTH, SAFETY AND WELFARE INTERESTS OF THE RESIDENTS; AMENDING THE SAN LUIS CITY CODE; REPEALING ANY CONFLICTING PROVISION; PROVIDING FOR SEVERABILITY; PROVIDING FOR PENALTIES; AND DECLARING AN EMERGENCY.

BE IT ORDAINED by the Mayor and City Council of the City of San Luis, Arizona, as follows:

**Section 1.** The San Luis City Code is amended by adding a heading and sections to Title IX: General Regulation, Chapter 94: Parks and Recreation as follows:

## CITY TREES

### § 94.30.010 DEFINITIONS.

As used in this Article, the following words and phrases shall have the meanings indicated:

**DAMAGE** – any injury to or destruction of a tree, including but not limited to: uprooting; severance of all or part the root system or main trunk; storage of material on or compaction of surrounding soil; a substantial change in the natural grade above a root system or around a trunk; surrounding the tree with impervious paving materials; or any trauma caused by accident or collision.

**DIRECTOR** – the Director of the Department of Parks and Recreation for the city and/or the Director's designee.

**NUISANCE** – any tree, or limb thereof, that has an infectious disease or insect; is dead or dying; obstructs the view of traffic signs or the free passage of pedestrians or vehicles;

or threatens public health, safety and welfare.

**GREENWAY** – the area along a public street between the curb and the sidewalk; or if there is no curb or sidewalk, the unpaved portion of the area between the street right-of-way line and the paved portion of the street or alley. The greenway may or may not have vegetation on it.

**PUBLIC PROPERTY** – all grounds and rights-of-way owned or maintained by the city.

**PUBLIC TREE** – any tree or woody vegetation on city-owned or city-maintained property or rights-of-way.

**TOP** – the non-standard practice of cutting back of limbs to stubs within a tree’s crown to such a degree as to remove the normal canopy and disfigure the tree.

**§ 94.30.020 PURPOSE.**

To enhance the quality of life and the present and future health, safety, and welfare of all residents and visitors, to enhance property values, and to ensure proper planting and care of Trees on Public Property, the San Luis City Council delegates the authority and responsibility for managing Public Trees, establishes practices governing the planting and care of Trees on Public Property, and makes provision for the emergency removal of trees on private property under certain conditions.

**§ 94.30.030 Authority and power.**

- (A) **Delegation** of authority and responsibility. The Director of the Parks and Recreation Department and/or his designee (Director), shall have full authority and responsibility to plant, prune, maintain and remove trees and woody plants growing in or upon all municipal streets, rights-of-ways, city parks, and other Public Property. This shall include the removal of trees that may threaten electrical, telephone, gas, or any municipal water or sewer line, or any tree that is affected by fungus, insect, or other pest disease.
  
- (B) **Coordination** among city departments. All city departments will coordinate as necessary with the Director and will provide services as required to ensure compliance with this ordinance as it relates to streets, alleys, rights-of-way, drainage, easements and other Public Properties not under direct jurisdiction of the Director.
  
- (C) **Interference.** No person shall hinder, prevent, delay, or interfere with the Director or his agents while engaged in carrying out the execution or enforcement of this ordinance.

**§ 94.30.040 Tree planting and care standards.**

- (A) Standards. All planting and maintenance of Public Trees shall conform to the American National Standards Institute (ANSI) A-300 "Standards for Tree Care Operations" and shall follow all tree care Best Management Practices (BMPs) published by the International Society of Arboriculture.
- (B) Requirements of franchise utility companies. The maintenance of Public Trees for utility clearance shall conform to all applicable utility industry standards.
- (C) Tree species list. The Director shall develop and maintain an official list of desirable tree species for planting on Public Property in two size classes: Ornamental (20 feet or less in height at maturity) and Shade (greater than 20 feet at maturity). Only trees from this approved list may be planted without written approval from the Director.
- (D) Planting distances. The Director shall develop and maintain an official set of spacing requirements for the planting of trees on Public Property. No tree may be planted within the visibility triangle of a street intersection or within ten (10) feet of a fire hydrant.
- (E) Planting trees under electric utility lines. Only trees listed as Ornamental trees on the official city tree species list may be planted under or within fifteen (15) lateral feet of any overhead utility wire.
- (F) Protection of Public Trees during construction. Any person, firm, corporation, or city department performing construction near any Public Tree must employ appropriate measures to protect the tree, including, but not limited to, placing barriers around the tree to prevent Damage.

**§ 94.30.050 Prohibition against harming Public Trees.**

- (A) It shall be unlawful for any person, firm or corporation to Damage, remove, or cause the Damage or removal of a tree on Public Property without written permission from the Director.
- (B) It shall be unlawful for any person, firm or corporation to attach any cable, wire or signs or any other object to any street, park, or Public Tree.
- (C) It shall be unlawful for any person, firm or corporation to "Top" any Public Tree. Trees severely damaged by storms or other causes, where best pruning practices are impractical may be exempted from this provision at the determination of the Director.

**§ 94.30.060. Adjacent owner responsibility.**

- (A) The owner of land adjacent to any city street or highway, when acting within the provisions of this ordinance, may plant and maintain trees in the adjacent greenway area. Property owners are responsible for the reasonable and routine maintenance of trees and other landscaping in the adjacent greenway area.
- (B) No property owner shall allow a tree, or other plant growing on his or her property or within the adjacent greenway to obstruct or interfere with pedestrians or the view of drivers, thereby creating a hazard. If an obstruction persists, the Director shall notify the property owner to prune or remove the tree or plant. If the owner fails to comply with the notice, the City may undertake the necessary work and charge the cost to the property owner.

**§ 94.30.070. Certain trees declared a Nuisance.**

- (A) Any tree, or limb thereof, on private property determined by the Director to have contracted a lethal, communicable disease or insect; to be dead or dying; to obstruct the view of traffic signs or the free passage of pedestrians or vehicles; or that threatens public health, safety, and welfare is declared a Nuisance and the City may require its treatment or removal.
- (B) Private property owners have the duty, at their own expense, to remove or treat Nuisance trees on their property. The City may remove such trees at the owner's expense if the owner does not comply with treatment and/or removal as specified by the Director within the written notification period.

**PENALTY**

**§ 94.99 Penalty.**

- (A) General. Any person violating any provision of this chapter, for which no other penalty is provided, shall be subject to the class one misdemeanor penalty provisions of § 10.99.
- (B) Alcoholic beverages. Upon conviction for violation of § 94.11, 94.12, 94.13 or 94.14, the sentence to be imposed shall be a fine of not more than \$500 or imprisonment for not more than 30 days, or both. A separate offense shall be deemed committed upon each day during or on which a violation occurs or continues.

- (C) Tobacco products. A person who violates § 94.20 of this chapter is responsible for a civil offense punishable under § 10.99. A separate offense shall be deemed committed upon each day during or on which a violation occurs or continues.
- (D) Trees. Any person, firm or corporation violating § 94.30.010 through § 94.30.070 shall be subject to the class one misdemeanor penalty provisions of § 10.99 for each offense.

**Section 2.** In the event of a conflict between the provisions of this ordinance and any other ordinance, resolution, order, regulation, or policy of the City of San Luis, the conflicting provisions are repealed, superseded, and replaced, and the provisions of this ordinance shall govern.

**Section 3.** If any section, subsection, sentence, clause, phrase or portion of this ordinance is for any reason held to be invalid or unconstitutional by the decision of any court of competent jurisdiction, such decision shall not affect the validity of the remaining portions of this ordinance.

**Section 4.** Whereas it is necessary for the preservation of the peace, health and safety of the City of San Luis, Arizona, an emergency is declared to exist, and this ordinance shall become immediately operative and in force from and after the date of the posting of this ordinance.

**PASSED, ADOPTED and APPROVED** by the Mayor and City Council of the City of San Luis, Yuma County, Arizona this \_\_\_\_ day of September 2020.

\_\_\_\_\_  
Gerardo Sanchez, Mayor

**ATTEST:**

**APPROVED AS TO FORM:**

\_\_\_\_\_  
Sonia Cornelio, City Clerk

\_\_\_\_\_  
Kay Marion Macuil, City Attorney



## AGENDA ITEM REVIEW FORM

### Regular City Council Meeting

6. E.

**Meeting Date:** 09/23/2020

**Department Head:** Roman Pacheco, Planning Technician, Planning & Zoning Department

**Submitted By:** Roman Pacheco, Planning Technician, Planning & Zoning Department

**Action Requested:** Motion

---

### ITEM:

Discussion and possible action on any and all matters regarding Subdivision Case No. 2020-076F. A request by Riedel Holdings LLC, property owner, for the final plat approval for Riedel Office Condominiums Subdivision to be located on Lot B-1 and B-2 of the Riedel Plaza Shopping Center, San Luis, Arizona. (**Jose A. Guzman, Director of Planning & Zoning**)

A. Staff presentation

B. Action on Subdivision Case No. 2020-076F

### SUMMARY:

This is a request by Riedel Holding LLC, owner, for the approval of the final plat for Riedel Office Condominiums, a condominium commercial subdivision. The subject property is located within the Riedel Commercial Plaza located on the northwest corner of Cesar Chavez Boulevard and 10th Avenue, Assessor's Parcel No. 77-28-206 and 776-28-207.

Lot B-1 and Lot B-2 of the Riedel Commercial Subdivision contains approximately 1.816 acres in total. These lots are part of the Riedel Plaza Shopping Center.

The entire shopping center contains 26.10 acres, it is zoned as Community Commercial (C-2). In addition to a grocery store, there are several retail spaces, restaurants, offices, and the Harvest Preparatory Academy. The area to the north has been developed with residential subdivisions. Bienestar 7B is zoned as Medium Density Residential (R-2) and Bienestar 7C is zoned as Low-Density Residential (R1-6). The area to the west and south is a county island and belongs to the Arizona State Land Trust. It is zoned as Rural Area Residential (RA-10) and is under county jurisdiction. The area to the east (across 10th Avenue) is undeveloped land owned by the Bureau of Land Management (BLM). It is currently zoned as Rural Area Residential (RA-10).

The project property is zoned as Community Commercial, which allows all types of commercial uses. The proposed subdivision consists of approximately 1.816 acres and will be a construction of 2 buildings with 6 suites each, a total of 12 suites.

### GENERAL PLAN:

This area is designated as an Activity Center in the City of San Luis 2020 General Plan. The activities proposed will be consistent with that designation. The Activity Center designation is intended for commercial services that conveniently serve the nearby residential areas.

### ANALYSIS:

In 2007, the Arizona Legislature adopted legislation that required municipalities to certify that all new subdivisions had an assured 100-year water supply. On February 11, 2011, the City of San Luis was

designated by the Arizona Department of Water Resources ( ADWR) as having a 100-year adequate water supply. Consequently, individual subdivisions do not have to submit additional certification.

Staff recommends approval of Subdivision Case No. 2020-076F for the final plat of Riedel Office Condominiums Commercial Subdivision with the condition that the applicant addresses all comments on the letter dated April 13, 2020.

**PLANNING AND ZONING COMMISSION:**

This item was presented to the Planning and Zoning Commission during their regular meeting of August 11, 2020. The Commission recommended approval of the request with the condition that the applicant had to address all review comments on the letter dated April 13, 2020, prior to presenting this item to the City Council.

**RECOMMENDATION / SUGGESTED MOTION:**

**I MOVE TO APPROVE SUBDIVISION CASE NO. 2020-076F SUBJECT TO THE CONDITION THAT THE APPLICANT ADDRESS THE COMMENTS ON THE LETTER DATED SEPTEMBER 23, 2020 TO THE PLANNING AND ZONING DEPARTMENT'S SATISFACTION.**

N/A

---

**Fiscal Impact**

<b>IS THERE FISCAL IMPACT ASSOCIATED WITH THIS ITEM:</b>	N/A
<b>CITY/STATE/FEDERAL FUNDS:</b>	N/A
<b>TOTAL:</b>	N/A
<b>BUDGETED AMOUNT:</b>	N/A
<b>AVAILABLE AMOUNT TO TRANSFER:</b>	N/A
<b>ACCT NAME &amp; GL#/REMAINING BALANCE BEFORE PURCHASE:</b>	N/A
<b>FISCAL IMPACT STATEMENT (IF THIS IS A BUDGET TRANSFER, YOU MUST ATTACH THE BUDGET ADJUSTMENT FORM):</b>	
	N/A

---

**Attachments**

Location Map  
Aerial Picture  
Final Plat  
Review Comments Letter Dated September 23, 2020  
Review Comments Letter Dated April 13, 2020  
Fire Department Comments  
Yuma County Health Services District Comments

---



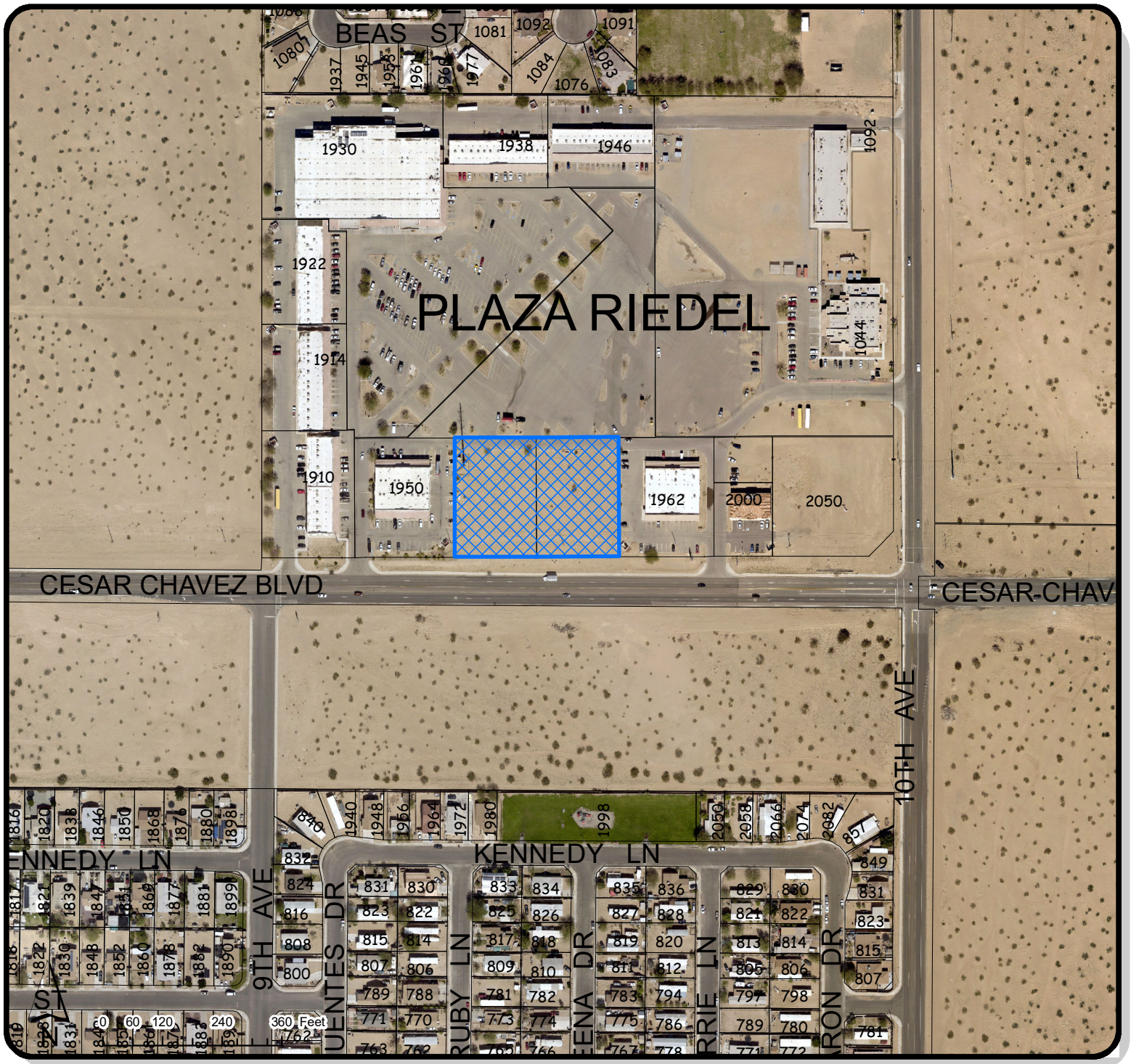

# LOCATION MAP

# SUBDIVISION

**LOCATION OF SUBJECT PROPERTY**

**CASE #**  
**2020-076F**

 PID: 776-28-206 & 776-26-207

**DATE:**  
3/5/2020

**PLANNING & ZONING**



**GIS**

**CREATED BY:**  
ISAAC GUTIERREZ

**CHECKED BY:**  
ROMAN PACHECO

**APPROVED BY:**  
JOSE A. GUZMAN

# RIEDEL OFFICE CONDOMINIUMS

A 12 SUITE CONDOMINIUM SUBDIVISION OF LOT B-1 & B-2 OF THE RIEDEL COMMERCIAL SUBDIVISION AS RECORDED ON BOOK 26 OF PLATS, PAGES 14-15, YUMA COUNTY RECORDS, YUMA COUNTY ARIZONA.

DATE: JANUARY 2020 ACREAGE: 1.816 ACRES

## FINAL PLAT

RECORDER'S CERTIFICATE

BOOK \_\_\_\_\_ OF PLATS,  
PAGE \_\_\_\_\_

RIEDEL HOLDINGS AZ, LLC.  
A.P.N. 776-28-214  
PARCEL: B-9 OF THE RIEDEL COMMERCIAL  
SUBDIVISION BOOK 26; PAGES 14-15 Y.C.R.  
ZONING C-2

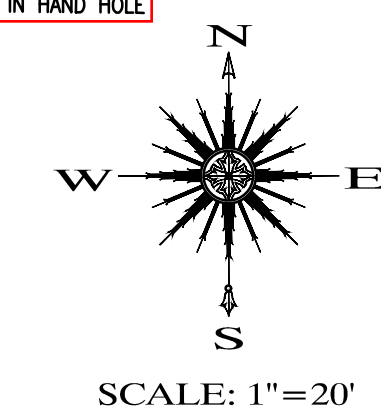

### LEGEND

- BOUNDARY LINE
- CENTERLINE
- RIGHT OF WAY LINE
- EX. EASEMENT LINE
- EXISTING LOT NUMBER
- BUILDING REFERENCE NUMBER
- SUITE REFERENCE NUMBER
- Y.C.R.O. INDICATES YUMA COUNTY RECORDERS OFFICE
- B.C. BRASS CAP
- H.H. HAND HOLE
- A.P.N. ASSESSOR PARCEL NUMBER
- FOUND MONUMENT (TYPE AS SHOWN)
- SET 1/2" REBAR W/ CAP R.L.S. No. 16528 UNLESS NOTED OTHERWISE
- DATA REFER TO RIEDEL COMMERCIAL SUBDIVISION PLAT RECORDED IN BOOK 26, PAGE 14 & 15 OF PLATS, YUMA COUNTY ARIZONA. BY: EDAS ENGINEERING INC. DATED OCTOBER 13, 2011.
- MEASURED.
- DRAINAGE EASEMENT

### LEGAL DESCRIPTION

BEING LOTS B-1 AND B-2 OF THE RIEDEL COMMERCIAL SUBDIVISION AS RECORDED IN BOOK 26 OF PLATS, PAGES 14 & 15, Y.C.R., YUMA COUNTY, ARIZONA.  
CONTAINING 1.816 ACRES

### BASIS OF BEARING

THE SOUTH LINE OF THE SOUTHEAST QUARTER OF SECTION 6 TOWNSHIP 11 SOUTH, RANGE 24 WEST OF THE G.&S.R.B.&M., YUMA COUNTY, ARIZONA, BEARING: N89°49'00"E AS SHOWN ON THE BOUNDARY SURVEY OF THE E2, E3, E4 OF SECTION 6 T11S, R24W, BY EDAS ENGINEERING INC. SIGNED JULY 12, 2000 BY JOHN C. ENGLISH II.

### LINE DATA

NUMBER	BEARING	DISTANCE
L1	S 44°18'06" E	12.00'
L2	N 45°41'54" E	23.43'
L3	N 45°41'54" E	11.23'
L4	N 45°41'54" E	8.87'
L5	N 45°41'54" E	27.10'

### CURVE DATA

NUMBER	DELTA ANGLE	RADIUS	ARC LENGTH
C1	135°00'00"	2.00'	4.71'
C2	44°37'60"	3.00'	2.33'
C3	89°00'00"	3.00'	4.71'
C4	90°00'00"	5.00'	7.85'
C5	180°00'00"	1.67'	5.24'
C6	135°22'00"	3.00'	7.08'

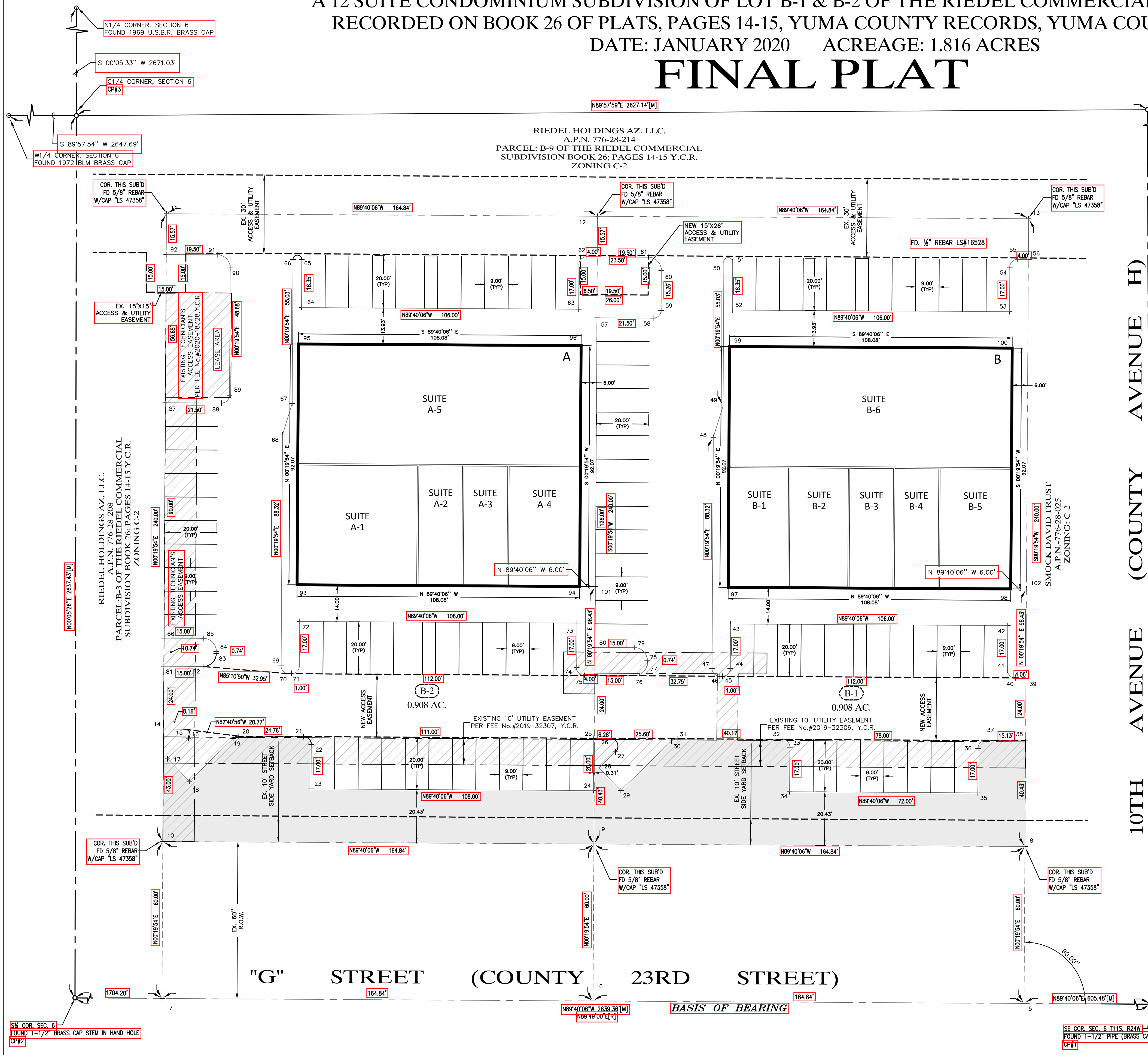

### DEDICATION

KNOW ALL MEN BY THESE PRESENTS: THAT RIEDEL HOLDINGS, L.L.C., AN ARIZONA LIMITED LIABILITY COMPANY, AS OWNER, HAS THIS DAY OF \_\_\_\_\_ 2020, CAUSED THE FOLLOWING DESCRIBED PROPERTY: A 12 UNIT CONDOMINIUM SUBDIVISION OF RIEDEL OFFICE, SAN LUIS, ARIZONA AS SHOWN HEREON, TO BE SUBDIVIDED INTO CONDOMINIUM UNITS AS PLATTED HEREON CONSISTING OF SHEETS 1 OF 4 UNDER THE NAME OF RIEDEL OFFICE CONDOMINIUM AND HEREBY DECLARES THAT THIS PLAT SETS FORTH THE LOCATION AND GIVES THE DIMENSIONS OF SUCH CONDOMINIUMS CONSTITUTING SAID SUBDIVISION AND THAT EACH CONDOMINIUM SHALL BE KNOWN BY THE UNIT NUMBER SHOWN ON SAID PLAT. RESERVATION AREAS WITHIN THE SUBDIVISION BOUNDARIES NOT DESIGNATED AS OCCUPIED CONDOMINIUMS SHALL BE RESERVED FOR THE COMMON USAGE BY THE OWNERS OF RIEDEL OFFICE CONDOMINIUM SAID COMMON USAGE AREAS ARE DEDICATED AS EASEMENTS OF ACCESS FOR UTILITIES, CABLE TELEVISION, TRASH COLLECTION, FIRE PROTECTION AND POLICE PROTECTION AS SPECIFICALLY SET FORTH IN THE DECLARATION OF RIEDEL OFFICE CONDOMINIUM HORIZONTAL PROPERTY REGIME TOGETHER WITH COVENANTS, CONDITIONS AND RESTRICTIONS AS RECORDED CONCURRENTLY WITH THIS PLAT IN THE YUMA COUNTY RECORDERS OFFICE.

IN WITNESS WHEREOF: RIEDEL HOLDINGS, L.L.C., HAS CAUSED ITS CORPORATE NAME TO BE SIGNED AND ITS CORPORATE SEAL TO BE AFFIXED BY THE SIGNATURE OF NIEVES GARCIA RIEDEL, AS MEMBER, THEREUNTO DULY AUTHORIZED ON THIS THE \_\_\_\_\_ DAY OF \_\_\_\_\_ 2020.

BY: \_\_\_\_\_  
NIEVES GARCIA RIEDEL, MEMBER  
RIEDEL HOLDINGS, L.L.C.

### ACKNOWLEDGMENT

STATE OF ARIZONA )  
) SS  
COUNTY OF YUMA )

ON THIS THE \_\_\_\_\_ DAY OF \_\_\_\_\_ 2020 BEFORE ME, THE UNDERSIGNED OFFICER PERSONALLY APPEARED NIEVES GARCIA RIEDEL, WHO ACKNOWLEDGED HERSELF TO BE MEMBER OF RIEDEL HOLDINGS, L.L.C., AN ARIZONA LIMITED LIABILITY COMPANY, AND SHE AS SUCH OFFICER BEING AUTHORIZED TO DO SO, EXECUTED THE FOREGOING INSTRUMENT FOR THE PURPOSES THEREIN CONTAINED, BY SIGNING THE NAME OF THE LIMITED LIABILITY COMPANY BY HERSELF, AS SUCH OFFICER.

IN WITNESS WHEREOF, I HAVE SET MY HAND AND OFFICIAL SEAL.

BY: \_\_\_\_\_  
NOTARY PUBLIC  
MY COMMISSION EXPIRES: \_\_\_\_\_

### APPROVED

STATE OF ARIZONA )  
) SS  
CITY OF SAN LUIS )

THIS SUBDIVISION AS PLATTED HEREON HAS BEEN APPROVED BY THE MAYOR AND THE CITY COUNCIL OF THE CITY OF SAN LUIS, ARIZONA.

MAYOR \_\_\_\_\_ DATE \_\_\_\_\_  
CITY MANAGER \_\_\_\_\_ DATE \_\_\_\_\_  
DIRECTOR OF PLANNING AND ZONING DEPARTMENT \_\_\_\_\_ DATE \_\_\_\_\_  
CITY ENGINEER \_\_\_\_\_ DATE \_\_\_\_\_  
CITY PUBLIC WORKS DIRECTOR \_\_\_\_\_ DATE \_\_\_\_\_

### SURVEYOR'S CERTIFICATE

I HEREBY CERTIFY THAT I AM A LAND SURVEYOR LISTED ON THE ROSTER OF ACTIVE REGISTRANTS BY THE STATE BOARD OF TECHNICAL REGISTRATION OF ARIZONA AND THAT THIS MAP CONSISTING OF ONE (4) SHEET CORRECTLY REPRESENTS A SURVEY MADE UNDER MY SUPERVISION, THAT ALL MONUMENTS SHOWN HEREON ACTUALLY EXIST AND THEIR POSITIONS ARE CORRECTLY SHOWN.

JUAN N. LOWELI  
R.L.S. No. 22767

PREPARED BY:  
  
Edais Engineering, Inc.  
3075 S. AVENUE 4 E  
YUMA, ARIZONA 85365  
(928) 344-3566

# RIEDEL OFFICE CONDOMINIUMS

A 12 SUITE CONDOMINIUM SUBDIVISION OF LOT B-1 & B-2 OF THE RIEDEL COMMERCIAL SUBDIVISION AS RECORDED ON BOOK 26 OF PLATS, PAGES 14-15, YUMA COUNTY RECORDS, YUMA COUNTY ARIZONA.

DATE: JANUARY 2020 ACREAGE: 1.816 ACRES

## FINAL PLAT

RECORDER'S CERTIFICATE



BOOK \_\_\_\_\_ OF PLATS,  
PAGE \_\_\_\_\_

Point Table			
Point #	Description	Northing	Easting
1	CP	545029.82	390940.19
2	CP	545045.09	388300.87
3	CP	547682.51	388305.04
4	CP	547684.06	390932.18
5	PROP	545033.32	390334.72
6	PROP	545034.28	390169.88
7	PROP	545035.23	390005.04
8	PROP	545093.32	390335.06
9	PROP	545094.28	390170.23
10	PROP	545095.23	390005.39
11	PROP	545335.23	390006.78
12	PROP	545334.27	390171.62
13	PROP	545333.32	390336.45
14	FC	545138.24	390005.64
15	FC	545138.14	390013.80
16	FC	545134.71	390015.17
17	FC	545126.86	390007.13
18	FC	545118.27	390015.52
19	FC	545134.64	390032.28
20	FC	545135.49	390034.40
21	FC	545135.35	390059.16
22	FC	545132.33	390062.14
23	FC	545115.33	390062.04
24	FC	545114.71	390170.04
25	FC	545134.71	390170.15

Point Table			
Point #	Description	Northing	Easting
26	FC	545134.67	390176.43
27	FC	545129.52	390178.51
28	FC	545123.33	390172.16
29	FC	545114.74	390180.54
30	FC	545133.67	390199.94
31	FC	545134.52	390202.05
32	FC	545134.29	390242.17
33	FC	545131.27	390245.16
34	FC	545114.27	390245.06
35	FC	545113.86	390317.06
36	FC	545130.86	390317.16
37	FC	545133.84	390320.17
38	FC	545133.75	390335.30
39	FC	545157.75	390335.44
40	FC	545157.78	390331.38
41	FC	545160.79	390328.37
42	FC	545177.79	390328.47
43	FC	545178.41	390222.47
44	FC	545161.41	390222.38
45	FC	545158.42	390219.36
46	FC	545158.43	390218.36
47	FC	545161.45	390215.38
48	FC	545249.76	390215.89
49	FC	545261.74	390219.62
50	FC	545316.77	390219.94

Point Table			
Point #	Description	Northing	Easting
51	FC	545316.75	390223.28
52	FC	545298.40	390223.17
53	FC	545297.79	390329.17
54	FC	545314.79	390329.27
55	FC	545317.77	390332.28
56	FC	545317.75	390336.28
57	FC	545295.44	390171.39
58	FC	545295.32	390192.90
59	FC	545298.30	390195.91
60	FC	545313.56	390196.00
61	FC	545318.59	390191.03
62	FC	545318.73	390167.53
63	FC	545298.74	390164.41
64	FC	545299.36	390058.41
65	FC	545317.71	390058.52
66	FC	545317.73	390055.18
67	FC	545262.69	390054.86
68	FC	545250.72	390051.13
69	FC	545162.40	390050.62
70	FC	545159.38	390053.60
71	FC	545159.52	390054.60
72	FC	545179.36	390057.72
73	FC	545178.75	390163.72
74	FC	545161.75	390163.62
75	FC	545158.73	390166.60

Point Table			
Point #	Description	Northing	Easting
76	FC	545158.62	390185.60
77	FC	545163.49	390190.63
78	FC	545164.33	390190.63
79	FC	545169.36	390185.67
80	FC	545169.44	390170.66
81	FC	545162.24	390005.78
82	FC	545162.15	390020.77
83	FC	545167.12	390025.80
84	FC	545167.86	390025.81
85	FC	545172.89	390020.84
86	FC	545172.98	390005.84
87	FC	545262.97	390006.36
88	FC	545262.85	390027.86
89	FC	545265.83	390030.88
90	FC	545314.51	390031.16
91	FC	545319.54	390026.19
92	FC	545319.66	390006.69
93	Bldg Corner	545193.36	390056.72
94	Bldg Corner	545192.74	390164.80
95	Bldg Corner	545285.43	390057.25
96	Bldg Corner	545284.81	390165.33
97	Bldg Corner	545192.41	390221.56
98	Bldg Corner	545191.79	390329.63
99	Bldg Corner	545284.48	390222.09
100	Bldg Corner	545283.85	390330.17

Point Table			
Point #	Description	Northing	Easting
101	CP to Bldg	545192.70	390170.80
102	CP to Bldg	545191.75	390335.63

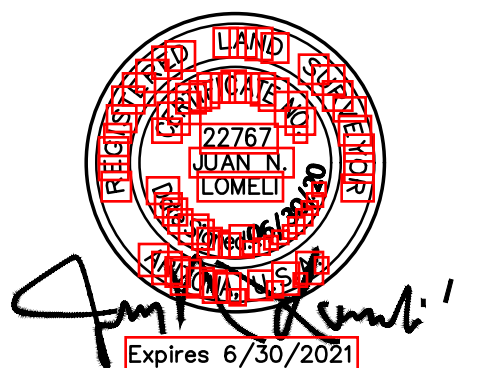

PREPARED BY :  
**Edais**  
 Engineering, Inc.  
 3075 S. AVENUE 4 E  
 YUMA, ARIZONA 85365  
 (928) 344-3566

# RIEDEL OFFICE CONDOMINIUMS

A 12 SUITE CONDOMINIUM SUBDIVISION OF LOT B-1 & B-2 OF THE RIEDEL COMMERCIAL SUBDIVISION AS RECORDED ON BOOK 26 OF PLATS, PAGES 14-15, YUMA COUNTY RECORDS, YUMA COUNTY ARIZONA.

DATE: JANUARY 2020 ACREAGE: 1.816 ACRES

## FINAL PLAT

RECORDER'S CERTIFICATE



BOOK \_\_\_\_\_ OF PLATS  
PAGE \_\_\_\_\_

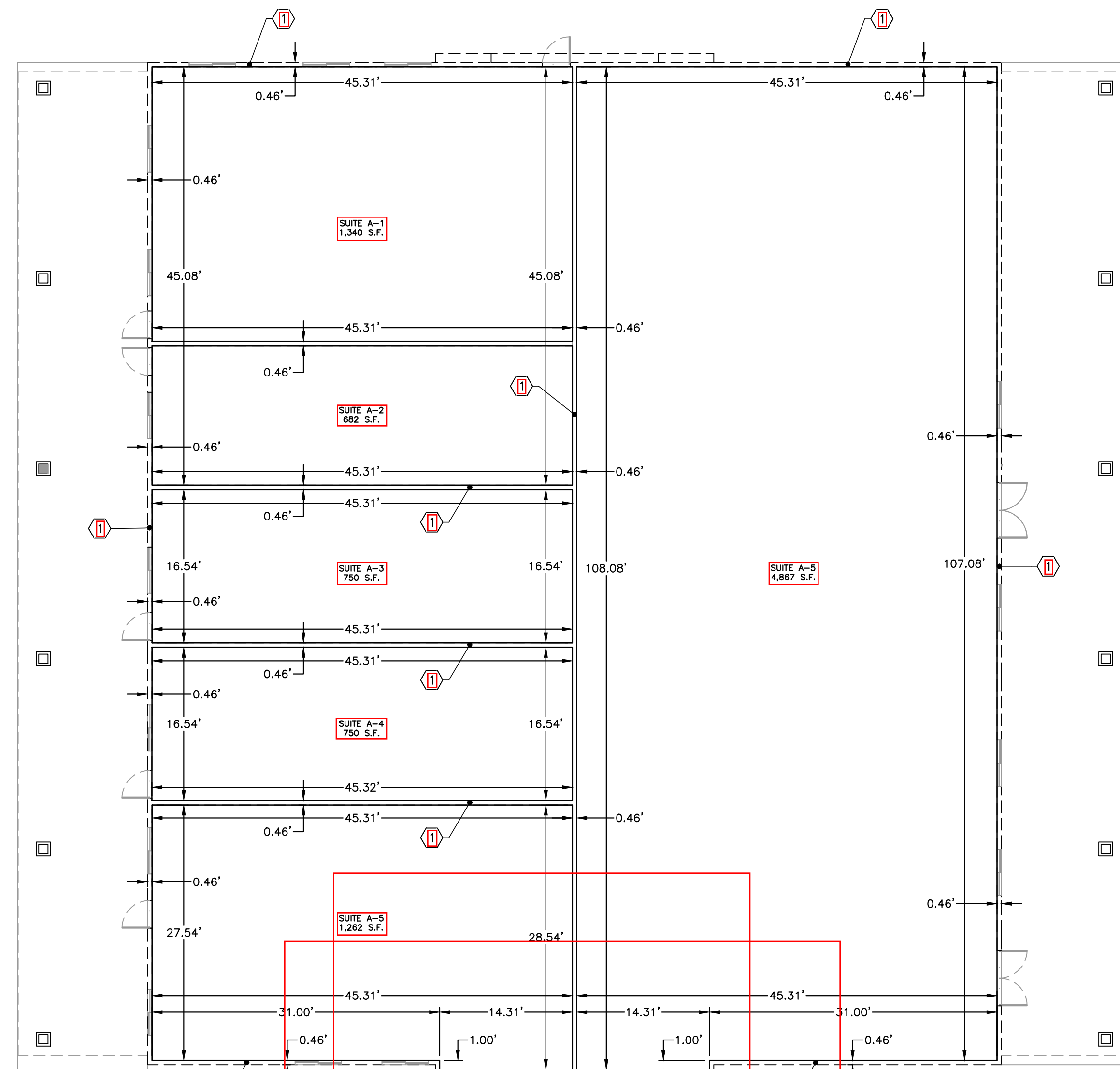

SUITE A  
PLAN VIEW

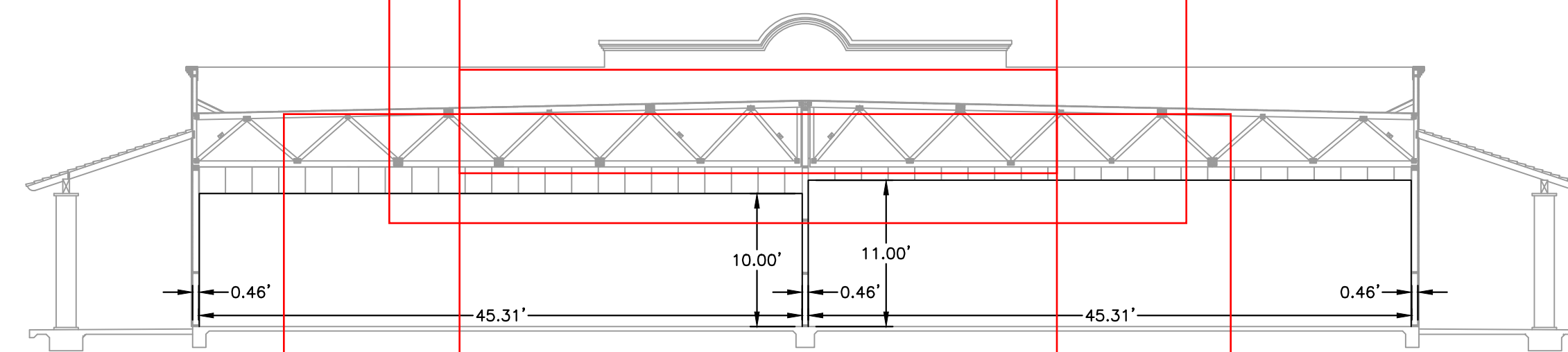

SUITE A  
BUILDING SECTION

**KEY NOTES**

① COMMON AREA - INTERIOR OF WALL

**NOTES**

1. ALL DIMENSIONS ARE FROM INTERIOR FACE OF WALL TO INTERIOR FACE OF WALL

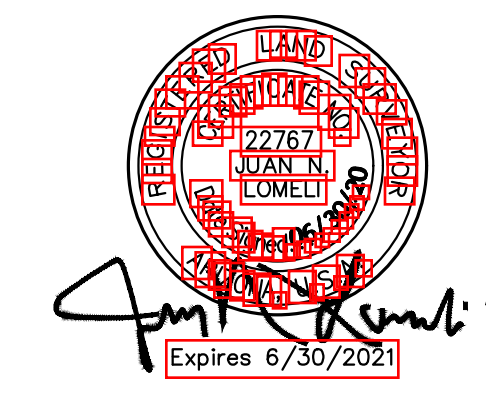

PREPARED BY:  
**Edais**  
Engineering, Inc.  
3075 S. AVENUE 4 E  
YUMA, ARIZONA 85365  
(928) 344-3566

# RIEDEL OFFICE CONDOMINIUMS

A 12 SUITE CONDOMINIUM SUBDIVISION OF LOT B-1 & B-2 OF THE RIEDEL COMMERCIAL SUBDIVISION AS RECORDED ON BOOK 26 OF PLATS, PAGES 14-15, YUMA COUNTY RECORDS, YUMA COUNTY ARIZONA.

DATE: JANUARY 2020 ACREAGE: 1.816 ACRES

## FINAL PLAT

RECORDER'S CERTIFICATE



BOOK \_\_\_\_\_ OF PLATS  
PAGE \_\_\_\_\_

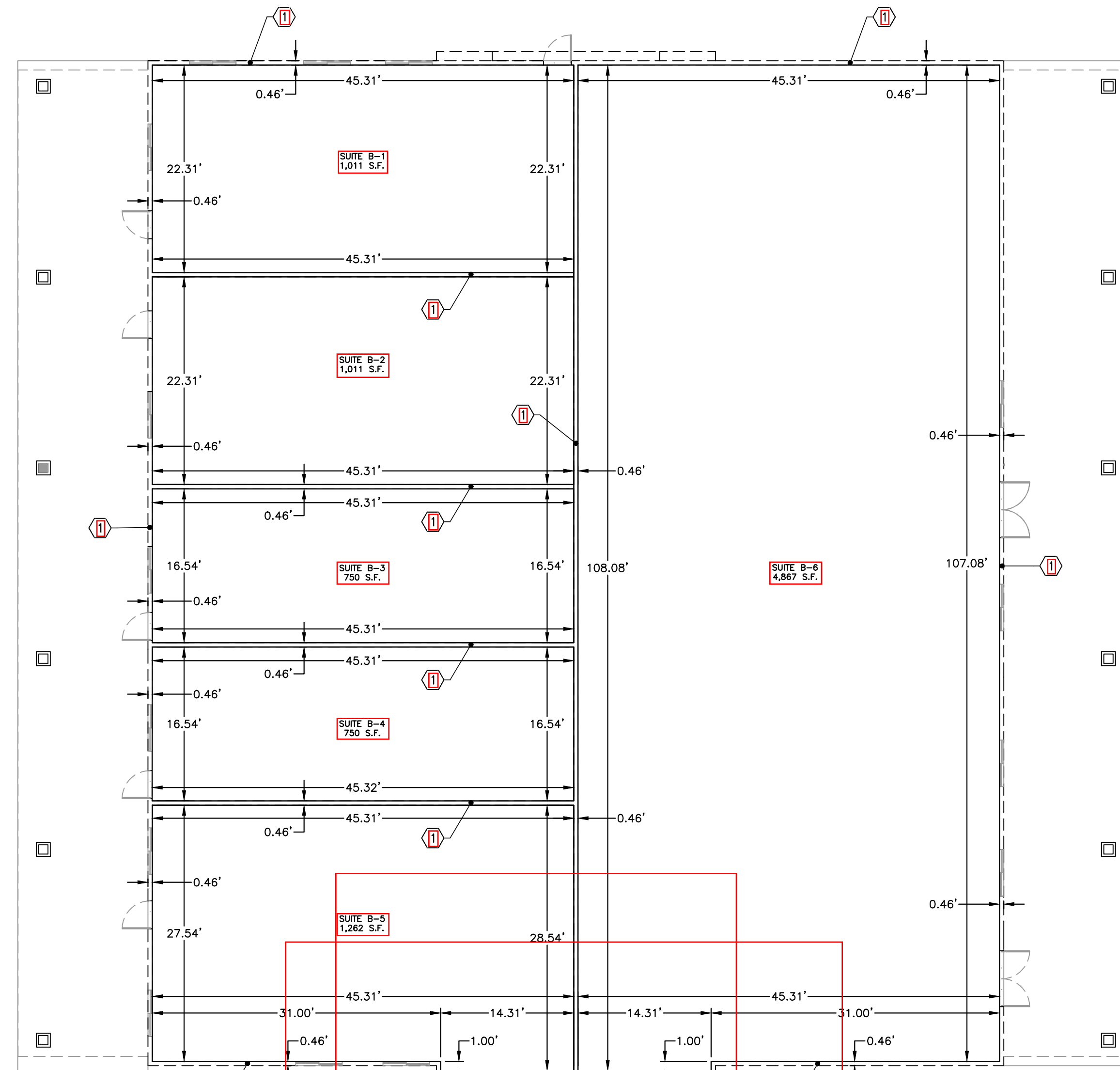

SUITE B  
PLAN VIEW

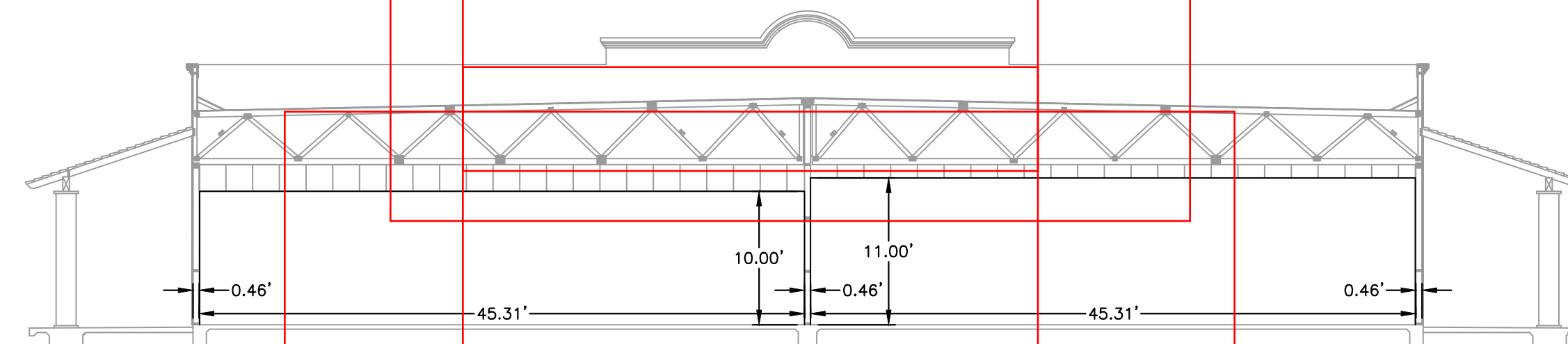

SUITE B  
BUILDING SECTION

**KEY NOTES**

① COMMON AREA - INTERIOR OF WALL

**NOTES**

1. ALL DIMENSIONS ARE FROM INTERIOR FACE OF WALL TO INTERIOR FACE OF WALL

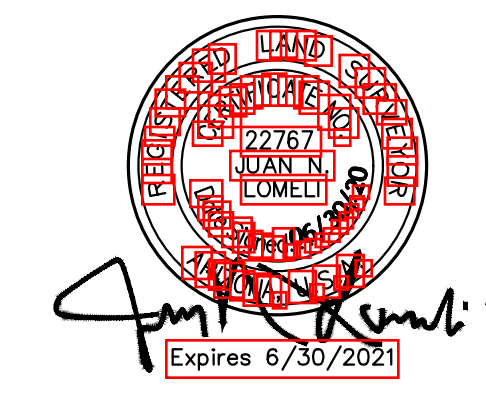

PREPARED BY:  
**Edais**  
Engineering, Inc.  
3075 S. AVENUE 4 E  
YUMA, ARIZONA 85365  
(928) 344-3566



# City of San Luis

## Planning and Zoning Department

Development Services · GIS · Building Safety · Code Enforcement

September 23, 2020

Nieves Riedel  
Riedel Holdings LLC  
PO Box 1649  
San Luis, AZ 85349

Re: Subdivision Case No. 2020-076F/Riedel Office Condominiums-Final Plat

City staff has reviewed the final plat for Santa Cecilia No. 3 Subdivision and have the following comments:

**Planning and Zoning Department:**

1. Creation of condominiums is subject to Arizona Revised Statutes Title 33 Chapter 9 Article 2, please provide documentation appropriately.
2. The condominiums shall be labeled as "Unit" and not as "Suite".
3. As per City Code § 152.107, 3% of open space shall be provided for this subdivision. Please provide calculations and location of open space. The required on-site parking areas/lot and the required parking lot landscaping shall not be calculated as open space. However, building setbacks, street frontage and on-site retention areas may be calculated as open space if those areas are landscaped.
4. Landscape plans review and construction can be done through the building permit process. However, landscape plans will be required and the property owner/association should properly maintain all landscape materials and landscaped areas, including that within the public rights-of-way adjacent to the development, in accordance with the approved landscape plan.
5. Parking shown on the plat is for owner's reference only. Staff will review the required parking spaces based on the uses at the time of the building permit or business license application.

Please be advised that the comments made here are tentative in nature. Until all documentation, information, and drawings are submitted and approved in final form, and all permits for construction are approved and issued, the City of San Luis reserves the right to make further comments or require further information or submissions. Any construction which occurs prior to issuance of proper permits is occurring in contravention of the ordinances of the City, and is occurring at the risk of the Developer.



# City of San Luis

## Planning and Zoning Department

Development Services · GIS · Building Safety · Code Enforcement

If you have any questions on these comments, please contact the Planning and Zoning Department at 928-341-8563.

Thank you,



Jose A. Guzman  
Director of Planning and Zoning



# City of San Luis

## Planning and Zoning Department

Development Services · GIS · Building Safety · Code Enforcement

April 13, 2020

Nieves Riedel  
Riedel Holdings LLC  
PO Box 1649  
San Luis, AZ 85349

Re: Subdivision Case No. 2020-076F-/Final Plat Riedel Office Condominiums

City staff has reviewed the final plat for Riedel Office Condominiums Subdivision and have the following comments:

**City Engineer:**

1. Show lot line between lots B1 and B2 to be abandoned.
2. Dedication says plat consists of 'sheets (sp.) 1 of 1' but the submitted plat consists of 4 sheets.
3. Dedication references CC&Rs for the condominiums. Have these been submitted?
4. How will common area be owned – partnership, corporation, etc.? Submit articles of incorporation or organization as appropriate.
5. There is a cell tower at the northwest corner of lot B-2. It appears that it is located on the common area of the Condominiums and the common area will be owned by the Riedel Office Condominiums condo owners association. Does it require any separate lot or easement?
6. Parking spaces and building sections should not be shown on final plat (ok to show on preliminary plat.) Submit separate site plans when building plans are submitted.
7. Show survey monuments to be set at subdivision boundary.
8. There is an APS powerline across the south side of the property. Show its easement if one exists.
9. It is noted that the 24' new access easement across the south side of the property physically connects to drive aisles on lots to the east and west but no matching access easements appear to have been dedicated on the adjacent lots.
10. "Reference Note" (misspelled) mentions a 'community building' but there is no community build shown.

**Public Works Department:**

1. Provide water and sewer plan
2. Provide drainage easements as need (don't know how they will handle storm water)



# City of San Luis

## Planning and Zoning Department

Development Services · GIS · Building Safety · Code Enforcement

### **Planning and Zoning Department:**

1. Creation of condominiums is subject to Arizona Revised Statutes Title 33 Chapter 9 Article 2, please provide documentation appropriately.

Please be advised that the comments made here are tentative in nature. Until all documentation, information, and drawings are submitted and approved in final form, and all permits for construction are approved and issued, the City of San Luis reserves the right to make further comments or require further information or submissions. Any construction which occurs prior to issuance of proper permits is occurring in contravention of the ordinances of the City, and is occurring at the risk of the Developer.

If you have any questions on these comments, please contact the Planning and Zoning Department at 928-341-8563.

Thank you,

Jose A. Guzman

Director of Planning and Zoning



March 9, 2020

**SUBDIVISION CASE NUMBER: 2020-076F**

**CASE SUMMARY:** A request by Riedel Holdings LLC, owner, for the final plat approval for Riedel Office Condominiums Subdivision. This condominium subdivision will contain approximately 1.816 acres per lot and will consists of two new buildings in lots B-1 and B-2 of the Riedel Commercial Subdivision. Building A and B will provide a total of 12 suites. The property is located at Cesar Chavez Boulevard, PID B-1 #776-28-206 & B-2 776-28-207, San Luis, Arizona.

**PUBLIC MEETING: April 14, 2020**

**COMMENTS DUE: March 16, 2020**

Your comments on this case will help us prepare an accurate and timely staff report. Your comments on this case will be inserted "as is" into the staff report with your name, department, and telephone number, should the applicant have any questions. Your comments are a public record and will be available to the public, media, and the applicant, in addition to the Commission hearing this case. Please complete the section below and return via e-mail. For additional information, please contact the Planning and Zoning Department at (928) 341-8563 or at [P&Z@sanluisaz.gov](mailto:P&Z@sanluisaz.gov).

Thank you,

Jose A. Guzman  
Director of Planning & Zoning  
Attachment: Location Map & Final Plat

.....  
 COMMENTS       NO COMMENTS

**Enter Comments below:**

The City of San Luis Fire Department has no comments at this time, but reserves the right to comment upon subsequent submittals. Final decisions regarding this request are best made by the Planning and Zoning Department.

**Date:**

03/10/20

**Agency:**

The City of San Luis Fire Department

**Phone:**

928/341-8550

**Return to:** [P&Z@sanluisaz.gov](mailto:P&Z@sanluisaz.gov)

## Jose A. Guzman

---

**From:** Roman Pacheco  
**Sent:** Thursday, April 9, 2020 5:55 PM  
**To:** Jose A. Guzman  
**Subject:** FW: Riedel Office Condominiums

FYI

---

**From:** Fernando Desarden <Fernando.Desarden@yumacountyaz.gov>  
**Sent:** Thursday, March 12, 2020 10:54 AM  
**To:** Roman Pacheco <RPacheco@sanluisaz.gov>  
**Cc:** Mark Flores <Marcos.Flores@yumacountyaz.gov>  
**Subject:** [EXTERNAL] Riedel Office Condominiums

Planning Technician Roman Pacheco,

Thank you for answering my questions this morning. As of now there are no specific requirements from the Health District. Just keep in mind that if there is going to be any commercial food storage, processing, peddling, cooking, selling, or distributing inside a suite they will have to comply with all Food Code requirement. Also we have delegated authority over Schools and Daycare Centers. They will have to submit plans to the Health District for evaluation. When building the project the builder should take into account the possibility of the installation of grease traps in the future for any food service operation.

Respectfully,

*Fernando Desarden*

Fernando Desarden, RS/REHS  
Environmental Health Programs Supervisor  
Yuma County Health Services District  
2200 W. 28<sup>th</sup> Street  
Yuma, Arizona 85365  
(928) 317-4584



## AGENDA ITEM REVIEW FORM

### Regular City Council Meeting

8. A.

**Meeting Date:** 09/23/2020

**Department Head:** Sonia Cornelio, City Clerk, City Clerk's Office

**Submitted By:** Sonia Cornelio, City Clerk, City Clerk's Office

**Action Requested:** Motion

---

#### ITEM:

Discussion and possible action to hold an executive session pursuant to A.R.S. § 38-431.03(A), subsections (1), (3) and (4) on any and all matters relating to the position of Magistrate and the employment, assignment, appointment, promotion, demotion, dismissal, salary, disciplining, or resignation of the position of the Magistrate, including discussion of possible confirmation of the City Manager's appointment of the Magistrate and/or discussion of approval of terms and/or conditions of said appointment pursuant to San Luis City Code §34.20, and consultation with the attorney or attorneys of the City regarding the same. **(Tadeo A. De La Hoya, City Manager)**

#### SUMMARY:

City Council can be properly advised by holding an executive session for the purposes described in the agenda item. Any proposed changes to the contract will be discussed in the executive session as permitted by the Open Meeting Law. The current employment contract is attached to the open session item.

#### RECOMMENDATION / SUGGESTED MOTION:

**I MOVE TO HOLD AN EXECUTIVE SESSION PURSUANT TO A.R.S. § 38-431(A) SUBSECTIONS (1), (3) AND (4).**

N/A

---

#### Fiscal Impact

**IS THERE FISCAL IMPACT ASSOCIATED WITH THIS ITEM:** N/A

**CITY/STATE/FEDERAL FUNDS:** N/A

**TOTAL:** N/A

**BUDGETED AMOUNT:** N/A

**AVAILABLE AMOUNT TO TRANSFER:** N/A

**ACCT NAME & GL#/REMAINING BALANCE BEFORE PURCHASE:** N/A

**FISCAL IMPACT STATEMENT (IF THIS IS A BUDGET TRANSFER, YOU MUST ATTACH THE BUDGET ADJUSTMENT FORM):**

The fiscal impact does not apply to this agenda item because, under A.R.S. §38-431.03(D), legal action involving a final vote or decision is not permitted during an executive session.

---



## AGENDA ITEM REVIEW FORM

### Regular City Council Meeting

8. B.

**Meeting Date:** 09/23/2020

**Department Head:** Sonia Cornelio, City Clerk, City Clerk's Office

**Submitted By:** Sonia Cornelio, City Clerk, City Clerk's Office

**Action Requested:** Motion

---

#### ITEM:

Discussion and possible action to hold an executive session pursuant to A.R.S. § 38-431.03(A), subsections (1), (3) and (4) on any and all matters relating to the position of Fire Chief and the employment, assignment, appointment, promotion, demotion, dismissal, salary, disciplining, or resignation of the position of Fire Chief, including discussion of possible confirmation of the City Manager's appointment of the Fire Chief and/or discussion of approval of terms and/or conditions of said appointment pursuant to San Luis City Code §34.04, and consultation with the attorney or attorneys of the city regarding the same. **(Tadeo A. De La Hoya, City Manager)**

#### SUMMARY:

City Council can be properly advised by holding an executive session for the purposes described in the agenda item. Any proposed changes to the contract will be discussed in the executive session as permitted by the Open Meeting Law. The current employment contract is attached to the open session item.

#### RECOMMENDATION / SUGGESTED MOTION:

**I MOVE TO HOLD AN EXECUTIVE SESSION PURSUANT TO A.R.S. § 38-431.03(A) SUBSECTIONS (1), (3) AND (4).**

N/A

---

#### Fiscal Impact

**IS THERE FISCAL IMPACT ASSOCIATED WITH THIS ITEM:** N/A

**CITY/STATE/FEDERAL FUNDS:** N/A

**TOTAL:** N/A

**BUDGETED AMOUNT:** N/A

**AVAILABLE AMOUNT TO TRANSFER:** N/A

**ACCT NAME & GL#/REMAINING BALANCE BEFORE PURCHASE:** N/A

**FISCAL IMPACT STATEMENT (IF THIS IS A BUDGET TRANSFER, YOU MUST ATTACH THE BUDGET ADJUSTMENT FORM):**

The fiscal impact does not apply to this agenda item because, under A.R.S. §38-431.03(D), legal action involving a final vote or decision is not permitted during an executive session.

---



## AGENDA ITEM REVIEW FORM

### Regular City Council Meeting

8. C.

**Meeting Date:** 09/23/2020

**Department Head:** Sonia Cornelio, City Clerk, City Clerk's Office

**Submitted By:** Sonia Cornelio, City Clerk, City Clerk's Office

**Action Requested:** Motion

---

#### ITEM:

Discussion and possible action to hold an executive session pursuant to A.R.S. § 38-431.03 (A), subsections (1), (3) and (4) on any and all matters relating to the position of Chief of Police and the employment, assignment, appointment, promotion, demotion, dismissal, salary, disciplining, or resignation of the position of Chief of Police, including discussion of possible confirmation of the City Manager's appointment of the Chief of Police and/or discussion of approval of terms and/or conditions of said appointment pursuant to San Luis City Code §32.02, and consultation with the attorney or attorneys of the City regarding the same. **(Tadeo A. De La Hoya, City Manager)**

#### SUMMARY:

City Council can be properly advised by holding an executive session for the purposes described in the agenda item. Any proposed changes to the contract will be discussed in the executive session as permitted by the Open Meeting Law. The current employment contract is attached to the open session item.

#### RECOMMENDATION / SUGGESTED MOTION:

**I MOVE TO HOLD AN EXECUTIVE SESSION PURSUANT TO A.R.S. § 38-431.03(A) SUBSECTIONS (1), (3) AND (4).**

No attachments

---

#### Fiscal Impact

**IS THERE FISCAL IMPACT ASSOCIATED WITH THIS ITEM:** N/A

**CITY/STATE/FEDERAL FUNDS:** N/A

**TOTAL:** N/A

**BUDGETED AMOUNT:** N/A

**AVAILABLE AMOUNT TO TRANSFER:** N/A

**ACCT NAME & GL#/REMAINING BALANCE BEFORE PURCHASE:** N/A

**FISCAL IMPACT STATEMENT (IF THIS IS A BUDGET TRANSFER, YOU MUST ATTACH THE BUDGET ADJUSTMENT FORM):**

The fiscal impact does not apply to this agenda item because, under A.R.S. §38-431.03(D), legal action involving a final vote or decision is not permitted during an executive session.

---



## AGENDA ITEM REVIEW FORM

### Regular City Council Meeting

10. A.

**Meeting Date:** 09/23/2020

**Department Head:** Sonia Cornelio, City Clerk, City Clerk's Office

**Submitted By:** Sonia Cornelio, City Clerk, City Clerk's Office

**Action Requested:** Motion

---

#### ITEM:

Discussion and possible action on any and all matters regarding the employment contract for the Magistrate. **(Tadeo A. De La Hoya, City Manager)**

#### SUMMARY:

As required by Arizona law, judicial contracts may be longer than two (2) years. The current contract term ended on August 27, 2020, but continues until action is taken on it. The Magistrate is a position created by city ordinance which states:

San Luis City Code §34.20 - "The presiding officer of the Magistrate's court shall be the City Magistrate, who shall be appointed by and shall serve at the pleasure of the Council."

#### RECOMMENDATION / SUGGESTED MOTION:

**I MOVE TO \_\_\_\_\_.**

**(NO SUGGESTED MOTION AT THIS TIME. CITY COUNCIL MAY MAKE SUCH MOTION AS COUNCIL MAY DESIRE REGARDING THE MATTER LISTED ON THE AGENDA.)**

N/A

---

#### Fiscal Impact

**IS THERE FISCAL IMPACT ASSOCIATED WITH THIS ITEM:** Yes  
**CITY/STATE/FEDERAL FUNDS:** City  
**TOTAL:** See fiscal impact stment  
**BUDGETED AMOUNT:** Yes  
**AVAILABLE AMOUNT TO TRANSFER:** N/A  
**ACCT NAME & GL#/REMAINING BALANCE BEFORE PURCHASE:** Salary and ERE accounts  
**FISCAL IMPACT STATEMENT (IF THIS IS A BUDGET TRANSFER, YOU MUST ATTACH THE BUDGET ADJUSTMENT FORM):**

The available budget for this contract is \$92,319.00 per year plus benefits.

---

#### Attachments

Current Employment Contract - Nohemy Echavarria

---

**CITY OF SAN LUIS, ARIZONA**  
**MAGISTRATE AGREEMENT**

---

**THIS MAGISTRATE AGREEMENT** (this “Agreement”) is made and entered into this 8<sup>th</sup> day of August, 2018, and shall be effective on the 27<sup>th</sup> day of August, 2018 (the “Effective Date”), by and between the CITY OF SAN LUIS, ARIZONA, a municipal corporation (“City”), and Nohemy Echavarria (“Magistrate”).

**WHEREAS**, the City desires to engage the services of Magistrate as the City Magistrate for the City of San Luis;

**WHEREAS**, the City will provide certain benefits and establish certain conditions of employment while Magistrate serves in this capacity; and

**WHEREAS**, the City desires to secure and retain the services of Magistrate, while providing a means for terminating Magistrate’s services at such time as Magistrate may be unable to discharge fully Magistrate’s duties or when the City or Magistrate may otherwise desire to terminate the employment relationship in accordance with law;

**NOW, THEREFORE**, in consideration of the mutual covenants herein contained, and for other good and valuable consideration, the receipt and sufficiency of which is hereby acknowledged, the City and Magistrate voluntarily and knowingly agree as follows:

**Section 1. Duties**

Magistrate shall perform the functions and duties specified in the City Code or as required by State law or Supreme Court rule or regulation. Magistrate shall also train Municipal Court staff on all necessary judicial procedures and recordkeeping. Magistrate shall further, to the greatest extent practicable, perform and cause Municipal Court staff to perform their functions and duties in accordance with all applicable City Personnel Policies, orders, directives, and any other policy or procedure.

**Section 2. Term**

A. The parties agree that this appointment is for a term of two years from the Effective Date (the "Term").

B. Nothing in this Agreement shall prevent, limit or otherwise interfere with the right of the City or Magistrate to terminate this Agreement, subject to the provisions set forth in Section 3 of this Agreement.

**Section 3. Termination**

A. Either party may terminate this Agreement upon 30 days' notice or upon such notice as may otherwise be mutually agreed upon.

B. In the event Magistrate is unable to discharge the duties of the office for any reason, the City may terminate this Agreement immediately.

C. Absent termination in accordance with Section 3(A), this Agreement shall automatically terminate at the end of the Term. The parties may, but shall not be obligated to, mutually agree to enter into a new agreement for a subsequent term of service.

**Section 4. Compensation**

City agrees to pay Magistrate an annual salary of \$85,000, paid bi-weekly in accordance with the City's payroll schedule. Magistrate shall be entitled to all health insurance and related benefits offered to other City employees.

**Section 5. Hours of Work**

Magistrate shall work during such hours as are necessary to operate properly and maintain the Magistrate Court.

**Section 6. Professional Development**

A. The City agrees to budget and to pay expenses reasonably incurred for professional and official travel, meetings, courses, institutes, seminars, and professional or organizational memberships that are reasonably necessary to support Magistrate's professional development and for the good of the City.

B. The City may, in its sole discretion, advance funds for purposes set forth in Section 6(A). In the event Magistrate terminates or notifies the City of her intent to terminate this Agreement prior to incurring the expense, Magistrate shall reimburse the City for any sums advanced. Magistrate further agrees that the City may withhold from her final paycheck any such advanced sums.

**Section 7. Other Terms and Conditions of Assignment**

A. The City Council shall fix any such other terms and conditions of Magistrate's appointment as it may determine from time to time, relating to the performance of Magistrate, provided that such terms and conditions are not inconsistent with or in conflict with provisions of this Agreement, the City Code, State law, or Supreme Court rule or regulation.

B. This Agreement is contingent upon Magistrate's continued membership in good standing with the State Bar of Arizona and continued acceptability by the Arizona Supreme Court and any other regulatory body that governs magistrate courts in the state of Arizona. In the event Magistrate is unacceptable at any time for any reason(s) by the State Bar of Arizona, the Arizona Supreme Court, or any other regulatory body, this Agreement is null and void. Magistrate agrees to advise the Mayor, City Management, and the City Attorney immediately should Magistrate receive any judicial conduct complaint, or should Magistrate become aware of any other matter that could possibly lead to removal from office, or otherwise result in not being able to fulfill her duties as the City Magistrate.

**Section 8. General Provisions**

A. This Agreement shall constitute the entire agreement between the parties.

B. If any portion of this Agreement is held invalid by operation of law, the remaining terms of this Agreement shall not be affected and shall remain in full force and effect.

C. A waiver of any right under this Agreement must be in writing to be effective. This Agreement may be amended only by a writing signed by the parties. Any oral representation or modification concerning this Agreement shall be of no force or effect.

D. The language of all parts of this Agreement shall in all cases be construed as a whole, according to its fair meaning, and not strictly for or against either of the parties. This Agreement shall be governed by and construed in accordance with the laws of the State of Arizona, except to the extent that federal laws apply. Any dispute or other legal action concerning this Agreement shall be conducted in a court of appropriate jurisdiction located in the State of Arizona.

E. This Agreement shall be subject to the cancellation provisions of A.R.S. § 38-511.

[SIGNATURES APPEAR ON FOLLOWING PAGE]

NOHEMY ECHAVARRIA

  
Magistrate

CITY OF SAN LUIS

  
Mayor

ATTEST:

  
City Clerk

APPROVED AS TO FORM:

  
City Attorney

4813-4563-1282, v. 1



## AGENDA ITEM REVIEW FORM

### Regular City Council Meeting

10. B.

**Meeting Date:** 09/23/2020

**Department Head:** Sonia Cornelio, City Clerk, City Clerk's Office

**Submitted By:** Sonia Cornelio, City Clerk, City Clerk's Office

**Action Requested:** Motion

---

### ITEM:

Discussion and possible action on any and all matters regarding the employment contract of the Fire Chief. **(Tadeo A. De La Hoya, City Manager)**

### SUMMARY:

As required by Arizona law, non-judicial positions specifically approved by City Council must have a maximum term of two (2) years. The current Fire Chief contract expires on October 9, 2020. The Fire Chief is a position created by city ordinance which states:

San Luis City Code §33.04 - "The Fire Chief shall be appointed by the City Manager, whose appointment shall be confirmed by the City Council, and shall serve at the pleasure of the City Manager on such terms and conditions as may be approved by the City Council. The Fire Chief shall be subject to the direction of the City Manager."

### RECOMMENDATION / SUGGESTED MOTION:

**I MOVE TO** \_\_\_\_\_ .

**(NO SUGGESTED MOTION AT THIS TIME. CITY COUNCIL MAY MAKE SUCH MOTION AS COUNCIL MAY DESIRE REGARDING THE MATTER LISTED ON THE AGENDA.)**

Employment Contract

---

### Fiscal Impact

**IS THERE FISCAL IMPACT ASSOCIATED WITH THIS ITEM:** Yes

**CITY/STATE/FEDERAL FUNDS:** City

**TOTAL:** TBD

**BUDGETED AMOUNT:** Yes

**AVAILABLE AMOUNT TO TRANSFER:** N/A

**ACCT NAME & GL#/REMAINING BALANCE BEFORE PURCHASE:** TBD

**FISCAL IMPACT STATEMENT (IF THIS IS A BUDGET TRANSFER, YOU MUST ATTACH THE BUDGET ADJUSTMENT FORM):**

To be determined. The available budget for this contract is \$103,521.60 plus benefits.

---

### Attachments

Current Employment Contract - Angel Ramirez

---



## EMPLOYMENT AGREEMENT

This agreement is effective as of October 9, 2018 and executed in the City of San Luis, County of Yuma, State of Arizona, between The City of San Luis, Arizona, (“City”), a municipal corporation of the State of Arizona, 1090 Union Street, San Luis, Arizona, and Angel Ramirez, referred to in this agreement as “Fire Chief.”

### **SECTION I TERM AND NATURE OF EMPLOYMENT**

Angel Ramirez has been the Acting Fire Chief as of February 14, 2017. This agreement is to remove the Acting relationship and make Angel Ramirez the Fire Chief of the City of San Luis. The term of this contract is two (2) years.

### **SECTION II DEVOTION OF FULL TIME TO BUSINESS**

The Fire Chief shall devote the whole of his time, attention, and energies to the performance of his duties as the Fire Chief of the City of San Luis, Arizona. Except he may continue on the substitute teacher list with the Yuma Union High School District and accept substitute teacher assignments only with the prior approval of the City Manager.

### **SECTION III DUTIES**

The Fire Chief shall perform the duties of Fire Chief as set forth in the ordinances, codes, rules, regulations and job description for Fire Chief of the City of San Luis and the applicable statutes and laws of the State of Arizona and shall perform such other duties as may be assigned or directed by the City Manager of the City of San Luis. Fire Chief, while a contract employee, shall be a department head subject to the management and direction of the City Manager as any other department head of the City of San Luis. The Fire Chief shall serve the City diligently and according to his best professional and personal abilities in all respects, and generally do all things for the best interests of the City that is usually done by persons occupying his position as the Fire Chief of a political subdivision.

### **SECTION IV RATE OF COMPENSATION; OTHER TERMS AND CONDITIONS**

- A. The salary of the Fire Chief shall be an annual base salary of \$102,500.00 payable biweekly effective as of October 9, 2018.
- B. The City Manager and City Council may review, evaluate, and complete the evaluation of the performance of the Fire Chief from time to time during the term of this agreement. The structure and timing of such review and evaluation, as well as any further adjustment in base salary or other compensation, shall be in the sole discretion of the Manager and City Council. The Manager and City Council shall not at any time during this contract reduce the salary, compensation, or other benefits for Fire Chief without the mutual consent of Fire Chief.

C. The City shall provide a fire vehicle for use by the Fire Chief and pay for all attendant operating and maintenance expenses and insurance. Said vehicle is to be used by the Fire Chief in connection with the performance of his duties as Chief, including professional growth and development. Said vehicle may not be used to commute to or from a residence not located within 25 minutes response time from the Fire Department of the City of San Luis.

D. The Council agrees to budget and pay for the professional dues and subscriptions of the Fire Chief as the Council deems necessary for his continuation and participation in national, regional, state and local associations and organizations necessary for his continued professional participation, growth and advancement, and for the good of the City.

E. Unless otherwise stated herein, Fire Chief shall be entitled to all other employment benefits provided for employees of the City which are not specifically mentioned herein, including, but not limited to, health insurance and participation in an employee retirement system, any cost of living adjustments made to employee compensation, leave benefits and accrual of leave.

F. It is recognized by the Manager and Council that Fire Chief must devote the time necessary to his duties involving both normal office hours and time outside these hours. The taking of personal time off should be in line with this premise, and rests in the discretion of Fire Chief under the supervision of the City Manager.

G. Indemnification. The City agrees to defend, save harmless and indemnify Fire Chief against any tort, professional liability claim or demand, or other civil legal action, whether groundless or otherwise, arising out of any alleged act or omission occurring in the performance of his duties as Fire Chief for the City, even if said claim has been made following his termination from employment, provided that the Fire Chief acted within the scope of his duties. The City may compromise and settle any such claim or suit and will pay the amount of any settlement or litigation costs, incidental expenses, and judgments rendered thereon without recourse to the Fire Chief.

## **SECTION V TERMINATION OF EMPLOYMENT**

A. The Manager and City Council may terminate this agreement at any time upon the giving of at least thirty (30) days' written notice to Fire Chief, unless the parties otherwise agree. In the event of resignation, the Fire Chief shall not be entitled to severance pay as provided in subsection D below.

B. Fire Chief may resign from his employment at any time upon the giving of at least thirty (30) days' written notice to the Mayor and Council, unless the parties otherwise agree.

C. Upon termination, in addition to any other rights to compensation or benefits to which Fire Chief may have under this agreement or law, the Fire Chief shall be paid his accumulated vacation time based upon the rate of salary as of the date of termination.

D. Upon termination by the City, in addition to subsections A through C above, the Fire Chief shall be entitled to severance pay equal to three (3) months of salary based upon the rate of salary as of the date of termination. In the event Fire Chief is terminated because of a conviction relating to any felony or a class one misdemeanor, a crime of moral turpitude, a material breach of any provision of this agreement, or an act of fraud, deception, misrepresentation, or active concealment of material facts, Council shall have no obligation to

make any extra payment pursuant to this subsection except for the Fire Chief's rights to compensation subsection C above. City Council reserves the right to suspend any severance payment pursuant to this subsection during any proceedings while felony or class one misdemeanor charges are pending.

**SECTION VI  
CONTRACT TERMS TO BE EXCLUSIVE**

This written agreement contains the sole and entire agreement between the parties and shall supersede any and all other agreements between the parties. The parties acknowledge and agree that neither of them has made any representation with respect to the subject matter of this agreement nor any representations inducing its execution and delivery except such representations as are specifically set forth in this writing and the parties acknowledge that they have relied on their own judgment in entering into the same. The parties further acknowledge that any statements or representations that may have been made by either of them to the other are void and of no effect and that neither of them has relied on such statements or representations in connection with its dealings with the other.

**SECTION VII  
WAIVER OR MODIFICATION INEFFECTIVE  
UNLESS IN WRITING**

It is agreed that no waiver or modification of this agreement or of any covenant, condition, or limitation contained in it shall be valid unless it is in writing and duly executed by the party to be charged with it, and that no evidence of any waiver or modification shall be offered or received in evidence in any proceeding, arbitration, or litigation between the parties arising out of or affecting this agreement, or the rights or obligations of any party under it, unless such waiver or modification is in writing, duly executed as above. The parties agree that the provisions of this paragraph may not be waived except by a duly executed writing.

**SECTION VIII  
CONTRACT GOVERNED BY LAW OF  
STATE OF ARIZONA**

A. The parties agree that it is their intention and covenant that this agreement and performance under it and all suits and special proceedings relating to it be construed in accordance with and under and pursuant to the laws of the State of Arizona and that in any action, special proceeding, or other proceeding that may be brought arising out of, in connection with, or by reason of this agreement, the laws of the State of Arizona shall be applicable and shall govern to the exclusion of the law of any other forum, without regard to the jurisdiction in which any action or special proceeding may be instituted.

B. In the event that the City adopts as a policy a program of settling employment claims or suits by binding arbitration, and adopts a form of agreement for new employees to sign during the course of this agreement, Fire Chief agrees to sign said agreement and be bound by the same.

C. This agreement shall be subject to the cancellation provisions of ARS §38-511.

In witness whereof, the City of San Luis, Arizona has caused this agreement to be signed and executed on its behalf by its City Manager and duly attested to by its Clerk, and Fire Chief, has signed and executed this agreement on the day and year as written below .

**City of San Luis, Arizona**

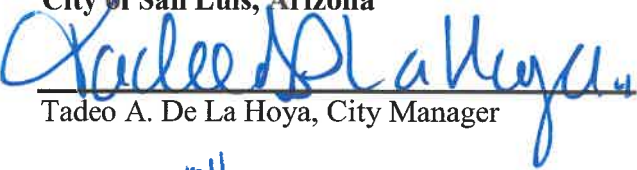

Tadeo A. De La Hoya, City Manager

Signed this 10<sup>th</sup> day of January 2019

**ATTEST:**

\_\_\_\_\_  
Sonia Cornelio, City Clerk

**APPROVED AS TO FORM:**

  
\_\_\_\_\_  
Kay Marion Macuil, City Attorney

**Angel Ramirez**

  
\_\_\_\_\_  
Angel Ramirez, Fire Chief

Signed this \_\_\_ day of January 2019



## AGENDA ITEM REVIEW FORM

### Regular City Council Meeting

10. C.

**Meeting Date:** 09/23/2020

**Department Head:** Sonia Cornelio, City Clerk, City Clerk's Office

**Submitted By:** Sonia Cornelio, City Clerk, City Clerk's Office

**Action Requested:** Motion

---

#### ITEM:

Discussion and possible action on any and all matters regarding the employment contract of the Chief of Police. (**Tadeo A. De La Hoya, City Manager**)

#### SUMMARY:

As required by Arizona law, non-judicial positions specifically approved by City Council must have a maximum term of two (2) years. The current Chief of Police contract written term was to September 12, 2020, but the contract continues until Council acts on it, which is this item. The Chief of Police is a position created by city ordinance which states:

San Luis City Code Section §32.02 - "The Chief of Police shall be appointed by the City Manager, whose appointment shall be confirmed by the City Council, and shall serve at the pleasure of the City Manager on terms and conditions as may be approved by the City Council. The Chief of Police shall be subject to the direction of the City Manager. The City Manager shall provide for the appointment of as many police officers as may from time to time be deemed necessary for the safety and good order of the city."

#### RECOMMENDATION / SUGGESTED MOTION:

**I MOVE TO** \_\_\_\_\_.

**(NO SUGGESTED MOTION AT THIS TIME. CITY COUNCIL MAY MAKE SUCH MOTION AS COUNCIL MAY DESIRE REGARDING THE MATTER LISTED ON THE AGENDA.)**

Employment contract

---

#### Fiscal Impact

**IS THERE FISCAL IMPACT ASSOCIATED WITH THIS ITEM:** Yes  
**CITY/STATE/FEDERAL FUNDS:** City  
**TOTAL:** TBD  
**BUDGETED AMOUNT:** Yes  
**AVAILABLE AMOUNT TO TRANSFER:** N/A  
**ACCT NAME & GL#/REMAINING BALANCE BEFORE PURCHASE:** XXX.XXX.50XXX See fiscal impact stmt

#### FISCAL IMPACT STATEMENT (IF THIS IS A BUDGET TRANSFER, YOU MUST ATTACH THE BUDGET ADJUSTMENT FORM):

To be determined. The available budget for this contract is \$103,521.60 plus benefits.

---

---

**Attachments**

Current Employment Contract - Richard Jessup

---

---

## **EMPLOYMENT AGREEMENT**

This agreement is effective as of September 12, 2018 at the City of San Luis, County of Yuma, State of Arizona, between The City of San Luis, Arizona, (“City”), a municipal corporation of the State of Arizona, 1090 Union Street, San Luis, Arizona, and Richard Jessup, referred to in this agreement as “Chief of Police.”

### **SECTION I TERM AND NATURE OF EMPLOYMENT**

Richard Jessup has been acting as the Acting Chief of Police. This agreement is to remove the Acting relationship and make Richard Jessup the Chief of Police of the City of San Luis. The term of this contract is 2 years.

### **SECTION II DEVOTION OF FULL TIME TO BUSINESS**

The Chief of Police shall devote the whole of his time, attention, and energies to the performance of his duties as the Chief of Police of the City of San Luis, Arizona.

### **SECTION III DUTIES**

The Chief of Police shall perform the duties of Chief of Police as set forth in the ordinances, codes, rules, and regulations of the City of San Luis and the applicable statutes and laws of the State of Arizona and shall perform such other duties as may be assigned or directed by the City Manager of the City of San Luis. Chief of Police, while a contract employee, shall be a department head subject to the management and direction of the City Manager as any other department head of the City of San Luis. The Chief of Police shall serve the City diligently and according to his best professional and personal abilities in all respects, and generally do all things for the best interests of the City that is usually done by persons occupying his position as the Chief of Police of a political subdivision. Chief of Police must maintain proper certification as a certified peace officer in good standing with the State of Arizona with the Arizona Police Officer Standards and Training Board (AZ POST) for the duration of his employment as San Luis Chief of Police.

### **SECTION IV RATE OF COMPENSATION; OTHER TERMS AND CONDITIONS**

A. The salary of the Chief of Police shall be an annual base salary of \$102,500.00 payable biweekly effective as of September 12, 2018. The Chief of Police shall be entitled to four (4) weeks of vacation per year. The first year to commence September 12, 2018.

B. The City Manager and City Council may review, evaluate, and complete the evaluation of the performance of the Chief of Police from time to time during the term of this agreement. The structure and timing of such review and evaluation, as well as any further adjustment in base salary or other compensation, shall be in the sole discretion of the Manager and City Council. The Manager and City Council shall not at any time during this contract reduce the salary, compensation, or other benefits for Chief of Police without the mutual consent of Chief of Police.

C. The City shall provide a police vehicle for use by the Chief of Police and pay for all attendant operating and maintenance expenses and insurance. Said vehicle is to be used by the Chief of Police in connection with the performance of his duties as Chief, including professional growth and development. Said vehicle may not be used to commute to or from a residence not located within 25 minutes response time from the Police Department of the City of San Luis.

D. The Council agrees to budget and pay for the professional dues and subscriptions of the Chief of Police as the Council deems necessary for his continuation and participation in national, regional, state and local associations and organizations necessary for his continued professional participation, growth and advancement, and for the good of the City.

E. Unless otherwise stated herein, Chief of Police shall be entitled to all other employment benefits provided for employees of the City which are not specifically mentioned herein, including, but not limited to, health insurance and participation in an employee retirement system and any cost of living adjustments made to employee compensation.

F. It is recognized by the Manager and Council that Chief of Police must devote the time necessary to his duties involving both normal office hours and time outside these hours. The taking of personal time off should be in line with this premise, and rests in the discretion of Chief of Police under the supervision of the City Manager.

G. Indemnification. The City agrees to defend, save harmless and indemnify Chief of Police against any tort, professional liability claim or demand, or other civil legal action, whether groundless or otherwise, arising out of any alleged act or omission occurring in the performance of his duties as Chief of Police for the City, even if said claim has been made following his termination from employment, provided that the Chief of Police acted within the scope of his duties. The City may compromise and settle any such claim or suit and will pay the amount of any settlement or litigation costs, incidental expenses, and judgments rendered thereon without recourse to the Chief of Police.

## **SECTION V TERMINATION OF EMPLOYMENT**

A. The Manager and City Council may terminate this agreement at any time upon the giving of at least thirty (30) days' written notice to Chief of Police, unless the parties otherwise agree. In the event of resignation, the Chief of Police shall not be entitled to severance pay as provided in subsection D below.

B. Chief of Police may resign from his employment at any time upon the giving of at least thirty (30) days' written notice to the Mayor and Council, unless the parties otherwise agree.

C. Upon termination, in addition to any other rights to compensation or benefits to which Chief of Police may have under this agreement or law, the Chief of Police shall be paid his accumulated vacation time based upon the rate of salary as of the date of termination.

D. Upon termination by the City, in addition to subsections A through C above, the Chief of Police shall be entitled to severance pay equal to three months of salary based upon the rate of salary as of the date of termination. In the event Chief of Police is terminated

because of a conviction relating to any felony or a class one misdemeanor, a crime of moral turpitude, a material breach of any provision of this agreement, or an act of fraud, deception, misrepresentation, or active concealment of material facts, Council shall have no obligation to make any extra payment pursuant to this subsection except for the Chief of Police's rights to compensation subsection C above. City Council reserves the right to suspend any severance payment pursuant to this subsection during any proceedings while felony or class one misdemeanor charges are pending.

**SECTION VI  
CONTRACT TERMS TO BE EXCLUSIVE**

This written agreement contains the sole and entire agreement between the parties and shall supersede any and all other agreements between the parties. The parties acknowledge and agree that neither of them has made any representation with respect to the subject matter of this agreement nor any representations inducing its execution and delivery except such representations as are specifically set forth in this writing and the parties acknowledge that they have relied on their own judgment in entering into the same. The parties further acknowledge that any statements or representations that may have been made by either of them to the other are void and of no effect and that neither of them has relied on such statements or representations in connection with its dealings with the other.

**SECTION VII  
WAIVER OR MODIFICATION INEFFECTIVE  
UNLESS IN WRITING**

It is agreed that no waiver or modification of this agreement or of any covenant, condition, or limitation contained in it shall be valid unless it is in writing and duly executed by the party to be charged with it, and that no evidence of any waiver or modification shall be offered or received in evidence in any proceeding, arbitration, or litigation between the parties arising out of or affecting this agreement, or the rights or obligations of any party under it, unless such waiver or modification is in writing, duly executed as above. The parties agree that the provisions of this paragraph may not be waived except by a duly executed writing.

**SECTION VIII  
CONTRACT GOVERNED BY LAW OF  
STATE OF ARIZONA**

A. The parties agree that it is their intention and covenant that this agreement and performance under it and all suits and special proceedings relating to it be construed in accordance with and under and pursuant to the laws of the State of Arizona and that in any action, special proceeding, or other proceeding that may be brought arising out of, in connection with, or by reason of this agreement, the laws of the State of Arizona shall be applicable and shall govern to the exclusion of the law of any other forum, without regard to the jurisdiction in which any action or special proceeding may be instituted.

B. In the event that the City adopts as a policy a program of settling employment claims or suits by binding arbitration, and adopts a form of agreement for new employees to sign during the course of this agreement, Chief of Police agrees to sign said agreement and be bound by the same.

C. This agreement shall be subject to the cancellation provisions of ARS §38-511.

In witness whereof, the City of San Luis, Arizona has caused this agreement to be signed and executed on its behalf by its City Manager and duly attested to by its Clerk, and Chief of Police, has signed and executed this agreement on the day and year referred to above.

  
Richard Jessup, Chief of Police

  
City Manager

Attest:

  
City Clerk

Approved as to form:

  
City Attorney