

RIEDEL OFFICE CONDOMINIUMS

A 12 SUITE CONDOMINIUM SUBDIVISION OF LOT B-1 & B-2 OF THE RIEDEL COMMERCIAL SUBDIVISION AS RECORDED ON BOOK 26 OF PLATS, PAGES 14-15, YUMA COUNTY RECORDS, YUMA COUNTY ARIZONA.

DATE: JANUARY 2020 ACREAGE: 1.816 ACRES

PRELIMINARY PLAT

RECORDER'S CERTIFICATE

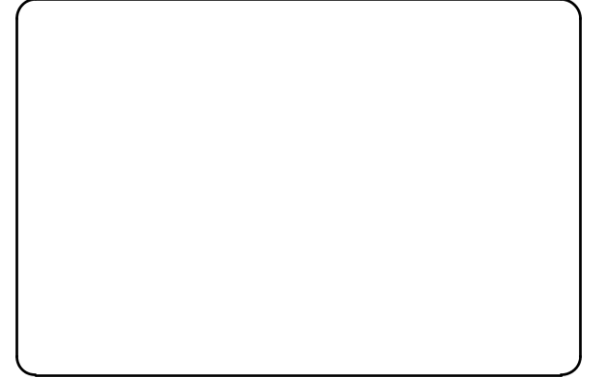

BOOK _____ OF PLATS,
PAGE _____

Point Table			
Point #	Description	Northing	Easting
1	CP	545029.82	390940.19
2	CP	545045.09	388300.87
3	CP	547682.51	388305.04
4	CP	547684.06	390932.18
5	PROP	545033.32	390334.72
6	PROP	545034.28	390169.88
7	PROP	545035.23	390005.04
8	PROP	545093.32	390335.06
9	PROP	545094.28	390170.23
10	PROP	545095.23	390005.39
11	PROP	545335.23	390006.78
12	PROP	545334.27	390171.62
13	PROP	545333.32	390336.45
14	FC	545138.24	390005.64
15	FC	545138.14	390013.80
16	FC	545134.71	390015.17
17	FC	545126.86	390007.13
18	FC	545118.27	390015.52
19	FC	545134.64	390032.28
20	FC	545135.49	390034.40
21	FC	545135.35	390059.16
22	FC	545132.33	390062.14
23	FC	545115.33	390062.04
24	FC	545114.71	390170.04
25	FC	545134.71	390170.15

Point Table			
Point #	Description	Northing	Easting
26	FC	545134.67	390176.43
27	FC	545129.52	390178.51
28	FC	545123.33	390172.16
29	FC	545114.74	390180.54
30	FC	545133.67	390199.94
31	FC	545134.52	390202.05
32	FC	545134.29	390242.17
33	FC	545131.27	390245.16
34	FC	545114.27	390245.06
35	FC	545113.86	390317.06
36	FC	545130.86	390317.16
37	FC	545133.84	390320.17
38	FC	545133.75	390335.30
39	FC	545157.75	390335.44
40	FC	545157.78	390331.38
41	FC	545160.79	390328.37
42	FC	545177.79	390328.47
43	FC	545178.41	390222.47
44	FC	545161.41	390222.38
45	FC	545158.42	390219.36
46	FC	545158.43	390218.36
47	FC	545161.45	390215.38
48	FC	545249.76	390215.89
49	FC	545261.74	390219.62
50	FC	545316.77	390219.94

Point Table			
Point #	Description	Northing	Easting
51	FC	545316.75	390223.28
52	FC	545298.40	390223.17
53	FC	545297.79	390329.17
54	FC	545314.79	390329.27
55	FC	545317.77	390332.28
56	FC	545317.75	390336.28
57	FC	545295.44	390171.39
58	FC	545295.32	390192.90
59	FC	545298.30	390195.91
60	FC	545313.56	390196.00
61	FC	545318.59	390191.03
62	FC	545318.73	390167.53
63	FC	545298.74	390164.41
64	FC	545299.36	390058.41
65	FC	545317.71	390058.52
66	FC	545317.73	390055.18
67	FC	545262.69	390054.86
68	FC	545250.72	390051.13
69	FC	545162.40	390050.62
70	FC	545159.38	390053.60
71	FC	545159.52	390054.60
72	FC	545179.36	390057.72
73	FC	545178.75	390163.72
74	FC	545161.75	390163.62
75	FC	545158.73	390166.60

Point Table			
Point #	Description	Northing	Easting
76	FC	545158.62	390185.60
77	FC	545163.49	390190.63
78	FC	545164.33	390190.63
79	FC	545169.36	390185.67
80	FC	545169.44	390170.66
81	FC	545162.24	390005.78
82	FC	545162.15	390020.77
83	FC	545167.12	390025.80
84	FC	545167.86	390025.81
85	FC	545172.89	390020.84
86	FC	545172.98	390005.84
87	FC	545262.97	390006.36
88	FC	545262.85	390027.86
89	FC	545265.83	390030.88
90	FC	545314.51	390031.16
91	FC	545319.54	390026.19
92	FC	545319.66	390006.69
93	Bldg Corner	545193.36	390056.72
94	Bldg Corner	545192.74	390164.80
95	Bldg Corner	545285.43	390057.25
96	Bldg Corner	545284.81	390165.33
97	Bldg Corner	545192.41	390221.56
98	Bldg Corner	545191.79	390329.63
99	Bldg Corner	545284.48	390222.09
100	Bldg Corner	545283.85	390330.17

Point Table			
Point #	Description	Northing	Easting
101	CP to Bldg	545192.70	390170.80
102	CP to Bldg	545191.75	390335.63



PREPARED BY :

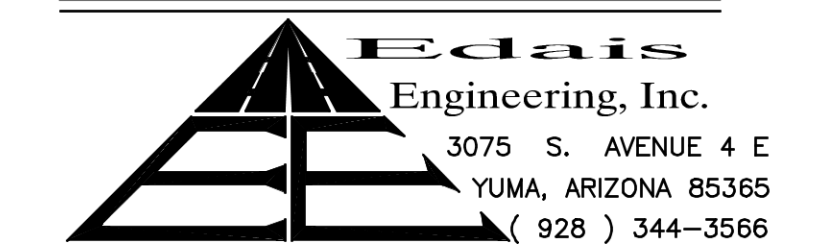

RIEDEL OFFICE CONDOMINIUMS

A 12 SUITE CONDOMINIUM SUBDIVISION OF LOT B-1 & B-2 OF THE RIEDEL COMMERCIAL SUBDIVISION AS RECORDED ON BOOK 26 OF PLATS, PAGES 14-15, YUMA COUNTY RECORDS, YUMA COUNTY ARIZONA.

DATE: JANUARY 2020 ACREAGE: 1.816 ACRES

PRELIMINARY PLAT

RECORDER'S CERTIFICATE



BOOK _____ OF PLATS,
PAGE _____

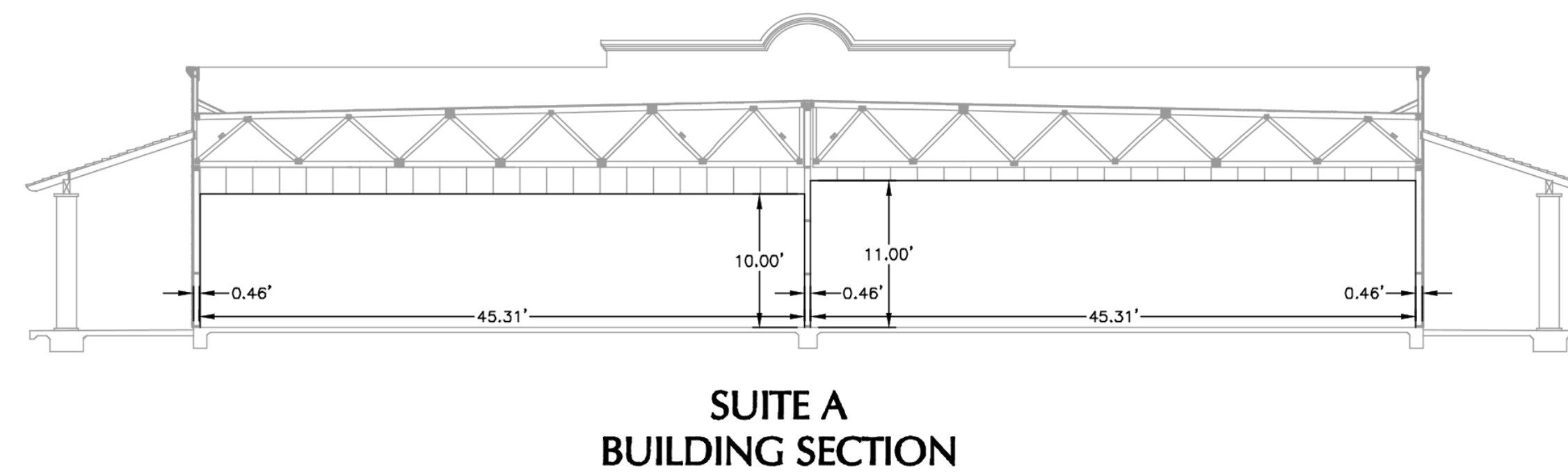
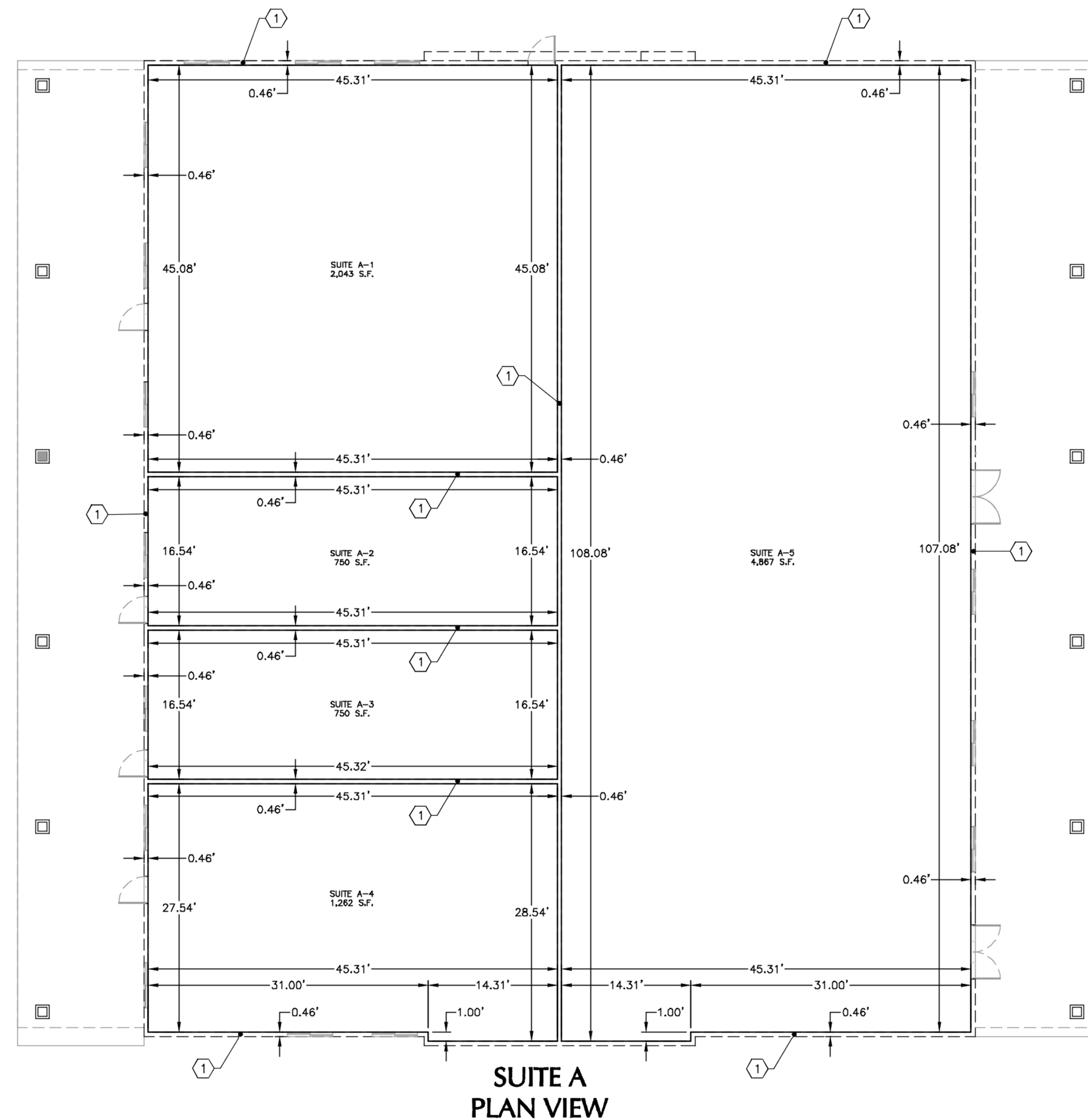

KEY NOTES

(1) COMMON AREA - INTERIOR OF WALL

NOTES

1. ALL DIMENSIONS ARE FROM INTERIOR FACE OF WALL TO INTERIOR FACE OF WALL

PREPARED BY :

Edais
Engineering, Inc.
3075 S. AVENUE 4 E
YUMA, ARIZONA 85365
(928) 344-3566



RIEDEL OFFICE CONDOMINIUMS

A 12 SUITE CONDOMINIUM SUBDIVISION OF LOT B-1 & B-2 OF THE RIEDEL COMMERCIAL SUBDIVISION AS RECORDED ON BOOK 26 OF PLATS, PAGES 14-15, YUMA COUNTY RECORDS, YUMA COUNTY ARIZONA.

DATE: JANUARY 2020 ACREAGE: 1.816 ACRES

PRELIMINARY PLAT

RECORDER'S CERTIFICATE



BOOK _____ OF PLATS,
PAGE _____

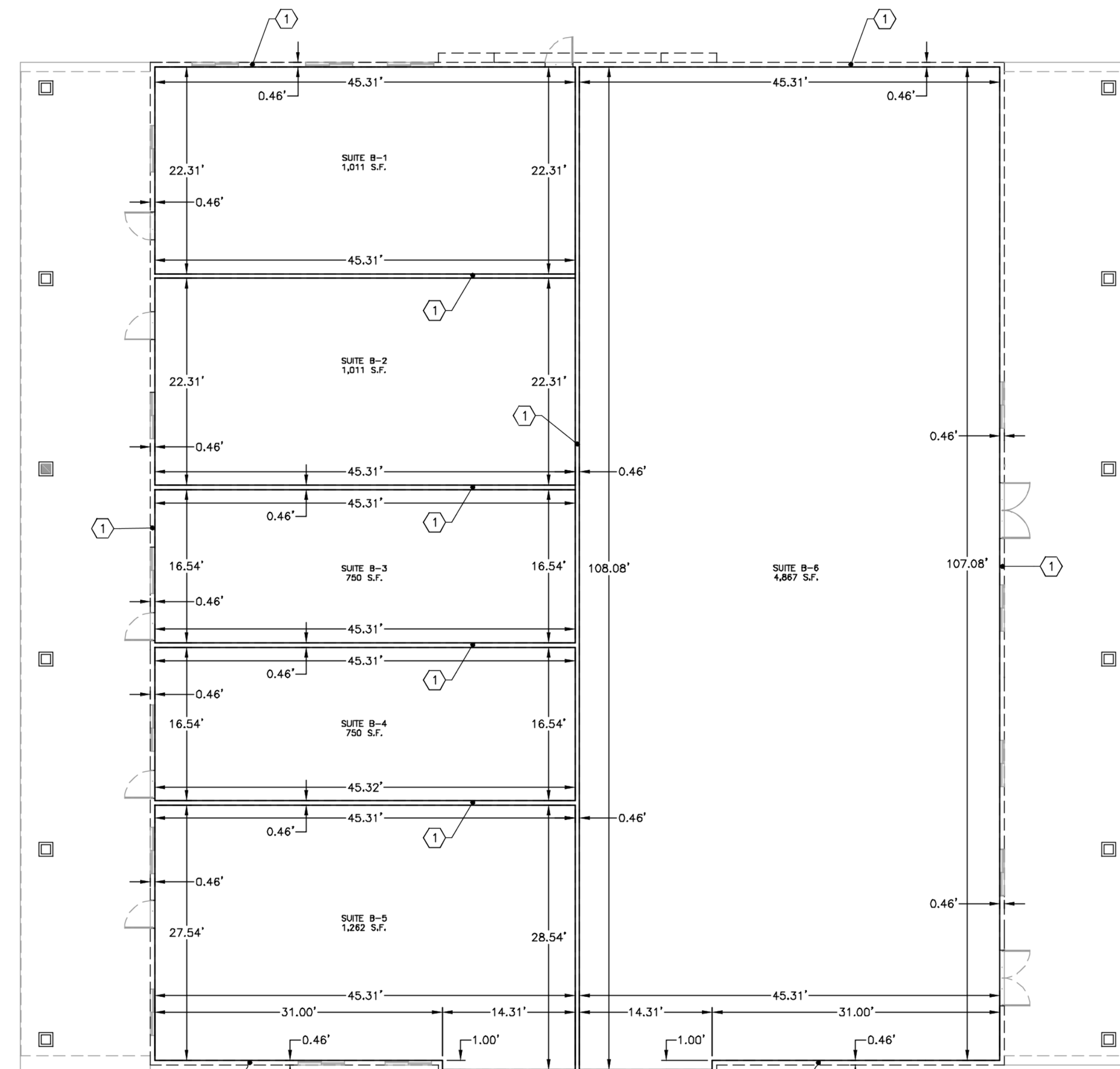

SUITE B
PLAN VIEW

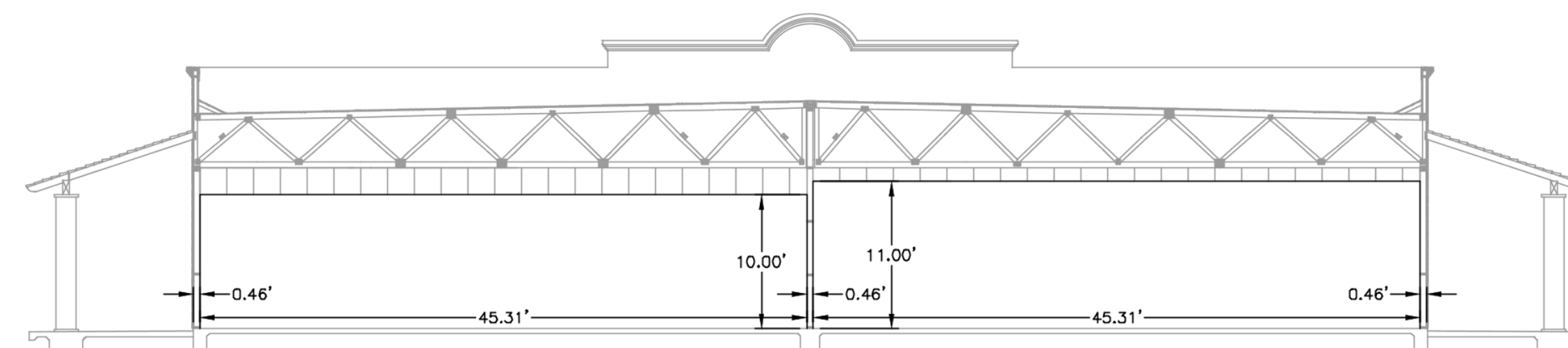

SUITE B
BUILDING SECTION

KEY NOTES

① COMMON AREA - INTERIOR OF WALL

NOTES

1. ALL DIMENSIONS ARE FROM INTERIOR FACE OF WALL TO INTERIOR FACE OF WALL

PREPARED BY :

Edais
Engineering, Inc.
3075 S. AVENUE 4 E
YUMA, ARIZONA 85365
(928) 344-3566

