

 Initial here to indicate content has been reviewed and Agreement is ready to be signed.

 Initial here to indicate content has been reviewed and Agreement is ready to be signed.

| | |
|------------------------------------------------------------------------------------------|--------------------|
| Agreement / CAR Number | GRT-20-0008022-T |
| AG Contract Number | P0012013003419 |
| AFIS Vendor Number & Address Code | DT0083 A0001 |
| AFIS Program/Phase Eligible From Date Eligibility Expiration Date Project Details | Refer to Exhibit A |

 Encumbrance Created

GRANT AGREEMENT
BETWEEN
THE ARIZONA DEPARTMENT OF TRANSPORTATION
MULTIMODAL PLANNING DIVISION acting for and on behalf of
THE STATE OF ARIZONA
AND
THE CITY OF SAN LUIS

This GRANT AGREEMENT, established pursuant to Arizona Revised Statutes (A.R.S.) § 28-7281, is entered into 2/23/2021 between the ARIZONA DEPARTMENT OF TRANSPORTATION (ADOT) MULTIMODAL PLANNING DIVISION (MPD) acting for and on behalf of THE STATE OF ARIZONA herein referred to as the STATE or ADOT, and the CITY OF SAN LUIS, a Local Government, herein referred to as the RECIPIENT. The STATE, ADOT, and the RECIPIENT are collectively referred to as the “Parties”, and individually as STATE, ADOT, RECIPIENT, and “Party”.

I. RECITALS

- 1) ADOT is authorized to enter into this Agreement and has delegated to the undersigned the authority to execute this Agreement on behalf of STATE.
- 2) RECIPIENT has obtained appropriate action by ordinance or resolution or otherwise pursuant to the laws or other rules and regulations applicable to it and its governing bodies and is authorized to enter into this Agreement and has delegated to the undersigned the authority to execute this Agreement on behalf of RECIPIENT.
- 3) Exhibit A: Project Award Description provides the Project Award Description, Eligibility Dates, Funding Participation, and Match Requirements. The STATE and the RECIPIENT desire to secure the Project as described in Exhibit A through the expenditure of State Economic Strength Project Funds and carried out according to this Agreement and under the applicable sections of ARS 28-7282 et seq.
- 4) Exhibit B: Program Description and Contact Information provides the statutory reference and describes rules, regulations, and requirements specific to the program(s) awarded in this Agreement. All the contacts needed for processing or communications are also provided.
- 5) Exhibit C: Responsibility Matrix delineates key requirements specific to roles. The STATE and the RECIPIENT desire defining their respective responsibilities related to the expenditure and

reimbursement of up to the amount of funds described in Exhibit A and referred to as the PROJECT within the authority granted by the Program described in Exhibit B.

- 6) Exhibit D: Procurement and Third Party Contract Provisions provides rules specific to RECIPIENT procurement in this Agreement.
- 7) Exhibit E: Discrimination & Title VI Requirements provides mandatory Title VI requirements.
- 8) Exhibit F: Disadvantaged Business Enterprise (DBE) Requirements provides mandatory DBE requirements.
- 9) Exhibit G: Insurance (Risk Management) Requirements provides mandatory insurance requirements.
- 10) Exhibit H: Language Modifications for Tribes, Nations, and Native American Communities provides exceptions, exemptions, and language variations for Agreements with Tribes, Nations, or Native American Indian Communities.
- 11) The RECIPIENT assures that it will comply with applicable provisions of the Americans with Disabilities Act (ADA), (Public Law No. 101-336, 42 U.S.C. 12101-12213) and all applicable federal regulations under the Act including 28 CFR parts 35-36, and applicable provisions of 49 CFR Parts 27, 37 and 38: Transportation for Individuals with Disabilities; Final Rule. The parties to this Agreement shall comply with Executive Order Number 2009-09 issued by the Governor of the State of Arizona and incorporated herein by reference regarding "Non-Discrimination".
- 12) RECIPIENT qualified local match and fees for the PROJECT to be procured by the STATE is due upon demand and prior to procurement. Match for PROJECT to be procured by RECIPIENT shall be indicated in and deducted from request for reimbursement.
- 13) The APPLICATION for this Agreement does not constitute the AWARD amount. The AWARD will be demonstrated in Exhibit A of this Agreement, incorporated into the document at the time of execution and/or as updated from time-to-time by mutual consent.
- 14) The State has the authority to re-distribute Award if the signed Agreement is not received by the program required deadline, or if applicable cash Match (if required) is not received, so that the Agreement may be executed within 90 calendar days from the date that Exhibit A documenting Award is distributed.

THEREFORE, in consideration of the mutual agreements expressed herein, it is agreed as follows:

II. SCOPE

- 1) RECIPIENT shall provide specific services or activities related to eligible funding, herein called the PROJECT in accordance with the RECIPIENT'S application(s), incorporated herein as referenced and as described in Exhibit B and the PROJECT description and Award described in Exhibit A.

- 2) PROJECT expense and cost awards will be detailed in Exhibit A. Awards may consist of any combination of expense or cost categories eligible in the associated grant program.
- 3) PROJECT Award is limited to the quantity, description, and/or pricing of the items identified in Exhibit A. Any needed or desired variation from quantity, description, or pricing must be requested in writing and approved by the Program Manager prior to procurement or incurring expenses. Approvals will result in a modified Exhibit A being issued. For PROJECT Award items being procured by ADOT, actual pricing that exceeds the estimate on Exhibit A and requiring additional MATCH will be confirmed with the RECIPIENT prior to purchase.
- 4) RECIPIENT eligible PROJECT expenditures or incurrence of costs may not occur prior to the "Expenses Eligible from Date" and must occur prior to the "Eligibility Expiration Date" established in Exhibit A. All support documentation must be dated within that established data range to be considered eligible.
- 5) Authorized PROJECT-appropriate expenses and costs associated with the PROJECT Award, supported by receipts and other suitable and appropriate documentation, and incurred within the Exhibit A established data range are eligible for reimbursement upon execution of this Agreement. Final reimbursement requests must be received no later than 30 calendar days after the calendar quarter within which the Eligibility Expiration Date occurs to be eligible for reimbursement unless an extension has been granted by the Program Manager. Extensions must be documented on a Modified Exhibit A.

III. RESPONSIBILITIES

1) ADOT or its assignees shall:

- a. Review PROJECTS for compliance with statutory requirements, oversight requirements, and program guidance.
- b. Review documentation supporting PROJECT expenditures for eligibility and ensure program match requirements are met.
- c. Assure funding is available to reimburse invoices submitted no later than 30 calendar days beyond the Eligibility Expiration Date of the Project unless the project is moved to an inactive status because no invoicing has been received for two consecutive calendar quarters.
- d. Review invoices, when appropriate to the Grant Award, from RECIPIENT and reimburse RECIPIENT within 30 calendar days after receipt and approval of invoices, in a total amount not to exceed the lesser of the approved invoiced costs or the Grant Award.
- e. Communicate with RECIPIENT as necessary to facilitate program compliance and procedural efficiency.

2) RECIPIENT shall:

- a. Administer the grant from award to closeout.
- b. Take necessary steps to ensure compliance with program or Agreement stipulated deadlines.

- c. Develop and have in place prior to use of award internal policies and systems that ensure effective management of awards and compliance with grant requirements.
- d. Implement strong internal controls for accounting and compliance with grant terms and conditions and ensure that RECIPIENT financial management system and any other system used for documentation or compliance is appropriate to implement the Project.
- e. Establish a budget of the costs required to perform the Project and a method for monitoring actual costs against the budget.
- f. Ensure that matching funds qualify under Program requirements and submit payment of Grant required MATCH or other fees as indicated in Exhibit A upon demand by the STATE.
- g. Comply with all terms of the Grant Program in accordance with the RECIPIENT application(s) and statutes in effect at the time of application or subsequently revised and incorporated herein by reference.
- h. Perform all tasks designated on the Responsibility Matrix. Copy the Arizona Corporation Commission (ACC) Project Manager on all progress or status reports from the matrix.
- i. Obtain prior written concurrence of the State before assigning any portion of the work to be performed under this Agreement or execute any contract, amendment, or change order thereto, or obligate itself in any manner with any third party with respect to its rights and responsibilities under this Agreement.
- j. Communicate contractual requirements to contractors and sub-contractors and ensure all the requirements of this Agreement are incorporated by means of a contract or other legally binding documents stipulating the contractor and/or sub-contractor's responsibility to comply with this Agreement.
- k. In the event of an accident involving any equipment funded under this Agreement, the RECIPIENT shall, within 48 hours, notify the ADOT Program Manager and the MPD Finance & Administration Manager (see Exhibit B) electronically via email. Any insurance proceeds received when project property has been lost or damaged, the grantee shall a) apply those proceeds to the cost of replacing the damaged or destroyed project property taken out of service or b) return an amount equal to the remaining STATE interest in the lost, damaged, or destroyed project property. The RECIPIENT agrees to request from and adhere to guidance from the ADOT Project Manager regarding which option shall be followed.
- l. Communicate with STATE as necessary to facilitate program compliance and procedural efficiency.
- m. Provide all required reports required by Program requirements or as requested by ADOT in a timely manner and as required by the STATE.
- n. Ensure users of PROJECT equipment and/or services meet applicable regulations and statutes.

- o. Review documentation supporting PROJECT expenditures for eligibility and ensure program match requirements are met.
- p. Comply with Performance Measure requirements when and as established or as designated by the STATE for its compliance.
- q. Comply with Cross-Cutting requirements for asset management plans and reporting of asset inventory and condition information when and as established by the STATE.
- r. Demonstrate that funds are expended for eligible and allocable activities; track receipts, disbursements, assets, liabilities, and balances; and track and report program income.
- s. Report to the STATE as required by the program but at a minimum so that payments may be completed quarterly on the Billing Summary and Reimbursement form provided by ADOT, for categorized reimbursable Project costs/expenses awarded as detailed in Exhibit A, as authorized and allowable under the grant requirements, and supported as required with vendor invoices, original receipts, or other suitable and appropriate documentation.

The final invoice for each State Fiscal Year for all work completed through June 30 each year shall be submitted no later than July 15 each year. In the event this deadline cannot be met, the RECIPIENT shall communicate with the MPD Finance Manager to establish a deadline for submission. Invoices received after the deadline for submission may be deemed non-reimbursable.

In the event that no expenditures occurred during a calendar quarter, submit a progress report to the ADOT Project Manager and explain the delay in the Project or reason for no billable charges. Projects with no billable activities for two consecutive quarters may be placed in an inactive status without this evidence.

To be eligible for reimbursement, costs must meet the following general criteria:

- Be a direct cost. Indirect costs are eligible for reimbursement only with an indirect cost plan approved by the RECIPIENTs federal cognizant agency and accepted by ADOT as indicated on Exhibit A.
- Be necessary and reasonable for proper and efficient performance and administration of the Project;
- Be an eligible expense under program regulations and requirements;
- Be treated consistently. A cost may not be assigned to the grant as a direct cost if any other cost incurred for the same purpose in like circumstances has been allocated to a grant as an indirect cost;
- Be determined in accordance with generally accepted accounting principles (GAAP);
- Be excluded as a cost or not used to meet cost sharing or matching requirements of any other award in either the current or a prior billing period;
- Be the net of all applicable credits; and
- Be adequately documented to include a system generated financial summary, or Excel spreadsheet accompanied by appropriate backup documentation (i.e. invoices, payroll, etc.), disclosing an expense amount that matches the invoice amount.

- t. Submit program required reports of procurement activities according to the section labeled: **PROCUREMENT AND THIRD PARTY CONTRACT PROVISIONS** and submit reports of contract activities via email in a spreadsheet template provided by the ADOT Program Manager.

IV. MISCELLANEOUS PROVISIONS

- 1) **Term Incorporation:** This Agreement is governed according to the laws of the State of Arizona. All cited statutes, public law, executive orders, and policies cited in this Agreement are incorporated by reference as a part of this Agreement. It is RECIPIENT responsibility to ensure that any Agreement between RECIPIENT and its CONTRACTORS and SUBCONTRACTORS for use of grant funds shall incorporate the provisions contained herein.
- 2) **Duration:** This Agreement shall become effective upon signature by the parties hereto and shall remain in force and effect until PROJECT satisfaction plus 36 months after Project completion.

This Agreement may be cancelled at any time prior to the commencement of performance under this Agreement, upon thirty (30) calendar days written notice to the other party.

- 3) **Amendments:** This Agreement may be amended upon mutual agreement of the Parties at any time when in the best interest of STATE, or RECIPIENT. Modifications to Exhibit A describing the details of the approved PROJECT may be modified without adopting a formal amendment to this Agreement; acceptance of the modification shall be indicated by signature on the modified Exhibit A by an authorized signatory from the RECIPIENT.
- 4) **Match:** Any needed or desired variation from quantity, description, or pricing must be requested in writing and approved by the Program Manager prior to procurement. Approvals will result in a modified Exhibit A being issued with updated approved not-to-exceed award, pricing, and MATCH indicated. Without advance approval, RECIPIENT is responsible for all of the increased price or quantity procured.

In the event that this Agreement is terminated after matching and/or fee funds have been issued to and deposited by the STATE, there is no guarantee of timeframe for refund of match funds, and refund shall not occur prior to the reassignment of the PROJECT award to another eligible agency and payment by that agency of any required matching funds. Remitted fees may be non-refundable, depending on the purpose of the fees except when this Agreement is terminated by ADOT or the STATE at no fault of the RECIPIENT.

In circumstances where the RECIPIENT cannot accept delivery of the Project Equipment or where surrender of equipment is required, refund of capital match will be based on current fair-market value at the time of surrender less the cost of any repairs or modifications required to affect reassignment to another recipient or program.

- 5) **Availability of Funds:** Every payment obligation of STATE under this Agreement is conditioned upon the availability of funds appropriated or allocated for the payment of such obligation. If funds are not allocated and available for the continuance of this Agreement, this Agreement may be terminated by STATE at the end of the period for which the funds are available. No liability shall accrue to STATE in the event this provision is exercised, and STATE shall not be obligated or liable for any future payments or for any damages as a result of termination under this paragraph.

- 6) **Statutory Compliance:** All parties shall comply with all applicable federal, state, and local requirements including all applicable provision of A.R.S. 28-7281 through 28-7286 et seq. and other applicable regulations where and when relevant.
- 7) **Conflict of Interest:** This agreement may be cancelled in accordance with Arizona Revised Statutes Section 38-511. The cancellation shall be effective when notified by the Department.
- 8) **Recordkeeping:** All RECIPIENTS and/or their CONTRACTORS and the parties shall retain all data, books, and other records relating to this Agreement for a period of five (5) years after completion of the Agreement. Completion of the Agreement means the awarded Project is completed or has been cancelled, all stated obligations and requirements have been met, all financial transactions are processed, and all required reporting has been completed. All records shall be subject to inspection and audit by the STATE at reasonable times as set forth in A.R.S. 35-214.
- 9) **Audit:** The administration of resources awarded by ADOT to the RECIPIENT may be subject to audits and/or monitoring by ADOT including but not be limited to: on-site visits by ADOT staff or designees, and limited scope audits. By entering into this Agreement, the RECIPIENT agrees to comply and cooperate fully with any monitoring procedures/processes deemed appropriate by ADOT. In the event ADOT determines that a limited scope audit of the RECIPIENT is appropriate, the RECIPIENT agrees to comply with any additional instructions provided by ADOT staff to the RECIPIENT regarding such audit. The RECIPIENT further agrees to comply and cooperate with any inspections, reviews, investigations, or audits deemed necessary by the ADOT's Office of Audit and Analysis, ADOT's Office of the Inspector General (OIG) and ADOT's Financial Management Services. It is the responsibility of the RECIPIENT to monitor their sub-recipients.

The RECIPIENT shall follow up and take corrective action on audit findings. Preparation of summary schedule of prior year audit findings, including corrective action(s), a timetable for resolution with anticipated completion date(s), person responsible for corrective action, and contact information, and current status of the audit findings are required to be submitted to ADOT. Current year audit findings require corrective action(s), a timetable for resolution with anticipated completion date(s), person responsible for corrective action, and contract information and status of findings will also be reported to ADOT.

If the RECIPIENT fails to take corrective action, ADOT will make a determination to:

- a. make financial adjustments to the allocated Federal funding as determined appropriate, up to and including repayment by the RECIPIENT of disallowed costs, or
- b. take other action as determined appropriate.

If the RECIPIENT has not completed corrective action, a timetable for follow-up should be provided with an explanation and specific reasons for non-completion.

Records related to unresolved audit findings, appeals, or litigation shall be retained until the action is completed or the dispute is resolved. Access to project records and audit work papers shall be given to ADOT and the Arizona Auditor General. This section does not limit the authority of ADOT to conduct or

arrange for the conduct of additional audits or evaluations of state financial assistance or limit the authority of any other state official.

Audit Report submission: Copies of reporting packages for audits conducted shall be submitted to SingleAudit@azdot.gov.

Copies of written communication between the RECIPIENT and the independent auditor in compliance with the Statement on Auditing Standards No 114 and as required by this section titled AUDIT of this agreement shall be submitted by or on behalf of the RECIPIENT directly to SingleAudit@azdot.gov.

- 10) **Dispute Resolution / Arbitration:** In the event of any controversy, the Parties agree that it is in their mutual best interest to promptly meet with the purpose of resolving said Dispute. In the event that the Parties cannot resolve their dispute informally, the parties hereto agree to abide by required arbitration as set forth for in Arizona Revised Statute 12-1518.
- 11) **Third Party Antitrust Violations:** The RECIPIENT assigns to the STATE any claim for overcharges resulting from antitrust violations to the extent that such violations concern materials or services supplied by third parties to the RECIPIENT toward fulfillment of this Contract.
- 12) **Immigration:** To the extent applicable under Arizona Revised Statutes Section §41-4401, each Party and its subcontractors warrants their compliance with all federal immigration laws and regulations that relate to their employees and their compliance with the E-verify requirements under Arizona Revised Statutes Section §23-214(A). A breach of the above-mentioned warranty by any Party or its subcontractors shall be deemed a material breach of the Agreement and may result in the termination of the Agreement by the non-breaching Parties. Each Party retains the legal right to randomly inspect the papers and records of the other Parties or its subcontractor employees who work on the Agreement to ensure that the Parties or its subcontractors are complying with the above-mentioned warranty.
- 13) **Termination for Convenience:** Either Party has the right to terminate the Agreement, in whole or in part at any time, when in the best interests of the RECIPIENT or STATE without penalty or recourse.
- 14) **Termination for Default:** STATE reserves the right to terminate this Agreement in whole or in part due to failure of RECIPIENT to carry out any term, promise, or condition of the Agreement. STATE will issue a written ten (10) day cure notice to RECIPIENT for failure to adequately perform, or if there is reason for STATE to believe that the RECIPIENT cannot or will not adequately perform the requirements of the Agreement. If RECIPIENT does not submit a Corrective Action Plan to the satisfaction of STATE within the ten (10) day period, then STATE may pursue action in accordance with the Agreement Article titled: *Arbitration*.
- 15) **Entire Agreement.** This Agreement may be amended, modified, or waived only by an instrument in writing signed by both Parties. Should the PROJECT awarded under this Agreement be completed at a lower cost than the amount awarded, or for any other reason should any of these funds not be expended, or expended in other than in strict accordance with the terms and conditions of this Agreement, a proportionate amount of the funds provided shall be reimbursed to the STATE. Except as identified in the PROJECT the RECIPIENT shall not assign any portion of the PROJECT or execute any agreement, contract, amendment, or change order thereto, or obligate itself in any manner with any

third party with respect to its rights and responsibilities under this Agreement without the prior written concurrence of the STATE.

16) **Title VI of the Civil Rights Act of 1964.** ADOT and its RECIPIENTS shall not discriminate against any employee or applicant for employment in violation of Federal Executive Order 11246, Arizona State Executive Order 2009-09, or A.R.S. 41-1461 through 1465, which mandates that all persons, regardless of race, color, religion, sex, age, or national origin shall have equal access to employment opportunities, and all other applicable state and federal employment laws, rules and regulations, including the Americans With Disabilities Act and shall comply with Title VI of the Civil Rights Act of 1964, as amended, 78 Stat. 252, 42 U.S.C. 2000d-42 U.S.C. 2000d-4 (hereinafter referred to as the Act), the Civil Rights Restoration Act of 1987 (Public Law 100.259). Refer to Exhibit E for requirements in contracting and procurement.

17) **Israel Boycott Not Permitted.** The RECIPIENT warrants that it is not engaged in a boycott of Israel as defined in A.R.S. 35-393 et seq.

18) **Duplicate Funding Not Permitted.** The RECIPIENT agrees that if it receives Federal funding from the Federal Emergency Management Agency (FEMA) or through a pass-through entity through the Robert T. Stafford Disaster Relief and Emergency Assistance Act, or any other Federal agency, or insurance proceeds for any portion of a project activity approved for funding under this Agreement, the RECIPIENT shall provide written notification to ADOT, and reimburse ADOT for any Federal share that duplicates funding provided by FEMA, another Federal agency, or an insurance company.

IN WITNESS WHEREOF, the parties have executed this Agreement the day and year first above written.

CITY OF SAN LUIS

**STATE OF ARIZONA
Arizona Department of Transportation**

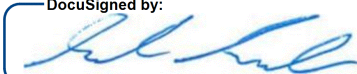
DocuSigned by:

By _____
B027DA48ABB8465...
Gerardo Sanchez, Mayor
Mayor

DocuSigned by:

By _____
6E1FEBD8FEEF421...
Gregory Byres, Division Director
Multimodal Planning Division

2/4/2021

2/23/2021

Date Signed

Date Signed

APPROVAL OF THE CITY OF SAN LUIS

I have reviewed this Grant Agreement BETWEEN the STATE OF ARIZONA, by and through its ARIZONA DEPARTMENT OF TRANSPORTATION, MULTIMODAL PLANNING DIVISION and the CITY OF SAN LUIS and declare this Agreement to be in proper form and within the powers and authority granted to the CITY OF SAN LUIS under the laws of the State of Arizona. No opinion is expressed as to the authority of the State to enter into this Agreement.

DATED 1/31/2021

DocuSigned by:

Kay Marion Macuil, City Attorney

BDF4259B52B5410...

Kay Marion Macuil, City Attorney

Attorney for the CITY OF SAN LUIS

Note: This page is mandatory for any public agency. If you are not a public agency, at your option, you may write "Acknowledged and Waived" above an authorized signatory's signature. It is recommended that you have an attorney review the document even if not mandatory.

Page to be replaced with UPLOADED document

AG Determination Letter



Exhibit A
PROJECT AWARD DESCRIPTION

| Award Description | Local Cash Match ¹ on Eligible Costs | Grant Award of ESP-Eligible Project Costs | Total Eligible Costs (Match + ESP-Eligible Costs) | ESP-Ineligible Project Costs ² | Total Estimated Project Cost (Match + ESP-Eligible + ESP-Ineligible Costs) |
|------------------------------------------------------------------------------------------------------------------------------------------------------------------------------------------------------------------------------------------------------------------------------------------------------------------------------------------------------------------------------------------------------------------------------------------------------------------------------------------------------------------------------------------------------------|-------------------------------------------------|-------------------------------------------|-------------------------------------------------------------|-------------------------------------------|----------------------------------------------------------------------------|
| ESP, GSL2001C, City of San Luis-Gary Magrino Industrial Park Subdiv 3-rural road Construction Project | \$50,000 | \$500,000 | \$1,347,653.06 | \$41,960 | \$1,389,613.06 |
| Eligible From Date | Agreement Execution Date | | Eligibility Expiration Date for Reimbursements ³ | | 18 months from Agreement Execution Date |
| The project will be paving a designated public roadway in a newly platted subdivision of City of San Luis-Gary Magrino Industrial Park Subdivision 3, located in San Luis, Arizona, adjacent to San Luis Port of Entry on the United States-Mexico border. | | | | | |
| ¹ You may not use Federal funds as Match for this grant. Cash match must be at least 10% of the Eligible Project Costs. The amount of eligible costs incurred beyond the ESP Grant is the responsibility of the RECIPIENT and may exceed 10%. ² These are costs that were not awarded for reimbursement from this ESP Grant but will be incurred as part of the total Project costs. ³ See Section II Scope, item (5) for final invoice deadlines. See Section IV, Miscellaneous item (2) for agreement completion. | | | | | |

Eligible Project Costs include but are not limited to:

- Public highway construction and/or reconstruction
- Turn Lanes
- Acceleration/deceleration lanes
- Utility placement within the public right of way that is a component of the overall public highway construction project
- Curb and gutter and/or other drainage construction associated with the overall public highway construction project

Costs ineligible for reimbursement or use as a match include but are not limited to:

- Application preparation
- Routine maintenance and rehabilitation
- Landscaping
- Beautification
- Construction of areas not designated for vehicular traffic such as sidewalks, etc.
- Work done on private property
- Signage for private companies
- Contingency fees
- Property purchase or easements
- Roadway and highway design and engineering
- Work done prior to the effective date of the ESP agreement
- Grant administration

EXHIBIT B
PROGRAM DESCRIPTION
Economic Strength Projects Grant Program
State of Arizona Highway User Revenue Fund 100%

The ESP is a competitive grant program designed to enhance the economic strength and competitiveness of Arizona rural communities by providing funding for highway projects that foster job growth. The ESP will reimburse specified costs of qualifying rural road and/or highway projects that are projected to accomplish one or more of the following: (i) retain a significant number of jobs, (ii) significantly increase the number of new jobs, (iii) foster significant private capital investment and (iv) otherwise make a significant contribution to the regional economy, particularly in base industries.

Administration of the ESP is shared between the Arizona Commerce Authority (ACA) and the Arizona Department of Transportation (ADOT). After initial screening by the ACA of eligible Projects and a recommended priority ranking of eligible Projects by the ACA's Rural Business Development Advisory Council (RBDAC), ADOT is charged with the final selection of approved Projects and with the contractual and financial administration of the Program. Further, see RFP Sections 3.1 and 4.1 and A.R.S. §§ 41-1505(E) and 28-7286(A).

Available Funding

Funding for the Program is allocated to ADOT through the Highway User Revenue Fund. The total amount available for grants pursuant to the ESP is \$1,000,000. The ACA and ADOT reserve the right to award less than \$1,000,000 in ESP grants depending on, among other considerations, the number and quality of Project proposals ("Proposals") received. Unallocated Program funds may be available for use in future Economic Strength Grant Project funding rounds. A single ESP grant award cannot exceed \$500,000. There is no prescribed minimum ESP grant award. The ACA and ADOT may choose to make one or more ESP grant awards.

Eligible Applicants

Applicants eligible for the ESP are as follows:

- Arizona incorporated cities and towns with populations of less than 150,000 (based on U.S. Census Bureau 2010 population data) not contiguous with or situated within a Metro Area
- Arizona counties with populations of less than 750,000 (based on U.S. Census Bureau 2010 population data)
- Federally recognized Indian tribes situated in Arizona.

| STATE Contact Information | | | | |
|----------------------------|--------------------------------------|-----------------------|-----------------------------|------------------------------------------|
| | Agreement Contact | Reimbursement Contact | ADOT Project Manager | ACC Project Manager |
| Name | Sally J. Palmer | Angela Ringor | Ungyo (Lynn) Sugiyama | Keith Watkins |
| Title | Contracts Program Manager | Senior Accountant | Transportation Planner 4 | Sr. VP of Economic and Rural Development |
| Email | SPalmer@azdot.gov | ARingor@azdot.gov | LUngyoSugiyama@azdot.gov | keithw@azcommerce.com |
| Phone | 602-712-6732 | 602-712-8316 | 602-712-6883 | 602-845-1278 |
| Invoice Submissions | MPDInvoice@azdot.gov | | | |
| Mailing Address | Arizona Department of Transportation | | | |
| | Multimodal Planning Division | | | |
| | Mail Drop 310B | | | |
| | 206 S. 17th Avenue | | | |
| | Phoenix, AZ 85007 | | | |

| RECIPIENT Contact Information | | | |
|-------------------------------|-----------------------------------------------------------------------------------------------------------------------|-----------------------------------------------------------------------------------------------------------------------------|-------------------------------------------------------------------------------------------------------------------------------------------------------|
| Contact info from Application | Contract Legal Signatory <i>Authorized to Execute Agreement</i> | Attorney Contact <i>Sign Determination (Agreement in proper form and within the powers and authority granted)</i> | Project Manager <i>Reviews Agreement Content and Starts signature process; Responsible for Managing Project and Tracking Progress</i> |
| Name | Mayor Gerardo Sanchez | Kay Macuil | Jenny Torres |
| Title | Mayor of San Luis | City Attorney | Economic Development Manager |
| Email | Gsanchez@sanluisaz.gov | Kmacuil@sanluisaz.gov | Jtorres@sanluisaz.gov |
| Phone | 928-341-8520 | 928-341-9117 | 928-341-8584 |
| Contact info from Application | Risk Manager OR Insurance Agent OR Broker <i>Signs Insurance Checklist and provides Insurance Documents</i> | Agreement Contact <i>Receives Executed Agreement for Official Agency Records (Optional)</i> | Accounting Contact <i>Receives Executed Agreement for Funding and Billing Records; Point of Contact for Questions on Billing (Optional)</i> |
| Name | Maria Sabori | Mayor Gerardo Sanchez | Monica Castro |
| Title | Risk Management Manager | Mayor of San Luis | Finance Director |
| Email | msabori@sanluisaz.gov | Gsanchez@sanluisaz.gov | Mcastro@sanluisaz.gov |
| Phone | 928-341-8552 | 928-341-8520 | 928-341-8553 |
| Mailing Address | City of San Luis | | |
| | 1090 E. Union St. San Luis, AZ 86349 | | |
| Remittance Address | City of San Luis | | |
| | PO Box 1170 San Luis, AZ 86349 | | |

EXHIBIT C
RESPONSIBILITY MATRIX

| Actions (not all-inclusive list) | RECIPIENT Responsibility | STATE / ADOT Responsibility |
|---------------------------------------------|--------------------------------------------------------------------------------------------------------------------------------------------------------------------------------------------------------------------------------|---------------------------------------------------------------------------------------------------------------------------------------------------------------------------|
| Agreement Reviews / Approval | Submit to attorney for review prior to presentation to the governing body; Governing body must take appropriate action to approve the IGA and provide evidence of said action | Draft and send to Awarded Recipient |
| Match Approval | Where required, obtain official approval/vote and submit to ADOT Contract Program Manager within 90 calendar days of notice of award, identifying original source (federal agency, local revenue, not-for-profit, for-profit.) | Review/Approve as eligible; Maintain Documentation |
| Execute Agreement | Sign Agreement and return within 60 calendar days of receipt | Execute Agreement within 90 calendar days from award of grant. |
| Procurement | Procure according to rules established in the Agreement. | Determine applicable procurement laws, rules, and regulations |
| Expenditures | Expenditures are only eligible upon the execution date of the Agreement and must be incurred within 18 months | Review/Approve as eligible and within permissible timeframe |
| Reimbursement Requests | Submit the first reimbursement request no later than 8 months after the effective date of the Agreement. Submit Reimbursement/Billing Summary form and adequate support documentation to MPDInvoice@azdot.gov | PM - Review and Approve/Reject within 7 calendar days; Grant Accountant - process payments within 14 calendar days from receipt |
| Match | Allocate at least 10% match to qualifying project costs on every reimbursement request, identifying fund source | Review/Approve as eligible. Grant funds from other State-funded programs, including the ACA's Rural Economic Development Grant ("REDG"), are ineligible as matching funds |
| Progress Reports | Submit within 20 calendar days after the close of each calendar quarter | Determine content and provide the forms. Track project outcomes relative to goals |
| Annual Outcome Report | Provide an annual outcome report for a period of 36 months | Track project outcomes relative to goals |
| Compliance | Comply with all applicable terms and conditions as stipulated in the Agreement and in the application guide. | Oversight & Contract Administration |

EXHIBIT D
PROCUREMENT AND THIRD PARTY CONTRACT PROVISIONS

In the event the RECIPIENT is authorized to procure Project construction services, RECIPIENT is responsible for following all procurement requirements established in the Agreement, by the Program, and applicable Arizona Revised Statutes. Include applicable contract provisions in every third-party contract and purchase order.

In the event that zero federal monies will be used as match and this project is not within the bounds of an existing federally funded project:

1. If the recipient is a local public agency or political subdivision of this state and has adopted the State Procurement Code pursuant to ARS 41-2501, the recipient shall follow the State Procurement Code. In the event the State Procurement Code has not been adopted, the recipient must reconcile the differences between local procurement rules and the State Procurement Code and receive authorization to proceed under local rules.
2. If the recipient has completed procurement self-certification processes through ADOT, the recipient shall follow the certified procurement rules.

In the event this project is within the bounds of an existing federally funded project, procurement of the portion of the project funded by these ESP dollars must be procured as required under the federally-funded project's requirements except that:

1. If the recipient is a local public agency or political subdivision of this state and has adopted the State Procurement Code pursuant to ARS 41-2501, the recipient shall follow the State Procurement Code except and unless a federal rule applicable pursuant to the rules of the funding agency is more restrictive, then it shall apply.
2. All other recipients shall follow 2 CFR 200.317 through 200.326 as applicable, Appendix II to Part 200, other CFR references provided in 2 CFR part 200 et seq. Contract provisions are available from <http://www.ecfr.gov>.
3. The regulations required by the federal funding agency shall be adhered to explicitly. The recipient must locate the federal funding agency required procurement requirements and contract provisions. For example: FHWA procurement requirements can be linked to at: <http://www.fhwa.dot.gov/construction/> and contract provisions are located at: <http://www.fhwa.dot.gov/construction/contracts/provisions.cfm>

EXHIBIT E
DISCRIMINATION & TITLE VI REQUIREMENTS
(REV 032018)

Title VI/Non-Discrimination Assurances: This Agreement is subject to the provisions of Title VI of the Civil Rights Act and the RECIPIENT is herein notified of such. Additionally, the RECIPIENT shall include the following information in each of its agreements/contracts associated with the WP.

*The **Arizona Department of Transportation**, in accordance with the provisions of Title VI of the Civil Rights Act of 1964 (78 Stat. 252.42 U.S.C. §§ 2000d-4) and the Regulations, hereby notifies all bidders that it will affirmatively ensure that any contract entered into pursuant to this advertisement, disadvantaged business enterprises will be afforded full and fair opportunity to submit bids in response to this invitation and will not be discriminated against on the grounds of race, color, or national origin in consideration for an award."*

APPENDIX A

During the performance of this contract, the contractor, for itself, its assignees, and successors in interest (hereinafter referred to as the "contractor") agrees as follows:

1. **Compliance with Regulations:** The contractor (hereinafter includes consultants) will comply with the Acts and the Regulations relative to Non-discrimination in Federally-assisted programs of the U.S. Department of Transportation, *Federal Highway Administration*, as they may be amended from time to time, which are herein incorporated by reference and made a part of this contract.
2. **Non-discrimination:** The contractor, with regard to the work performance by it during the contract, will not discriminate on the grounds of race, color, or national origin in the selection and retention of subcontractors, including procurements of materials and leases of equipment. The contractor will not participate directly or indirectly in the discrimination prohibited by the Acts and the Regulations, including employment practices when the contract covers any activity, project, or program.
3. **Solicitations for Subcontracts, Including Procurements of Materials and Equipment:** In all solicitations, either by competitive bidding, or negotiation made by the contractor for work to be performed under a subcontract, including procurements of materials, or leases of equipment, each potential subcontractor or supplier will be notified by the contractor of the contractor's obligations under this contract and the Acts and Regulations relative to Non-discrimination on the grounds of race, color, or national origin.
4. **Information and Reports:** The contractor will provide all information and reports required by the Acts, the Regulations, and directives issued pursuant thereto and will permit access to its books, records, accounts, other sources of information, and its facilities as may be determined by the Recipient or the *Federal Highway Administration* to be pertinent to ascertain compliance with such Acts, Regulations, and instructions. Where any information required of a contractor is in the exclusive possession of another who fails or refuses to furnish the information, the contractor will so certify to the Recipient or the *Federal Highway Administration*, as appropriate, and will set forth what efforts it has made to obtain the information.
5. **Sanctions for Noncompliance:** In the event of a contractor's noncompliance with the Non-discrimination provisions of this contract, the Recipient will impose such contract sanctions as it or the *Federal Highway Administration* may determine to be appropriate, including, but not limited to:
 - a. withholding payments to the contractor under the contract until the contractor complies; and/or
 - b. cancelling, terminating, or suspending a contract, in whole or in part.
6. **Incorporation of Provisions:** The contractor will include the provisions of paragraphs one through six in every subcontract, including procurements of materials and leases of equipment, unless exempt by the Acts, the Regulations and directives issued pursuant thereto. The contractor will take action with request to any subcontract or procurement as the Recipient or the *Federal Highway Administration* may direct as a means of enforcing such provisions including sanctions for noncompliance. Provided, that if the contractor becomes involved in, or is threatened with litigation by a subcontractor or supplier because of such direction, the contractor may request the Recipient to enter into any litigation to protect the interests of the Recipient. In addition, the contractor may request the United States to enter into the litigation to protect the interests of the United States.

APPENDIX E

During the performance of this contract, the contractor, for itself, its assignees, and successors in interest (hereinafter referred to as the "contractor") agrees to comply with the following non-discrimination statutes and authorities; including but not limited to:

Pertinent Non-Discrimination Authorities:

- Title VI of the Civil Rights Act of 1964 (42 U.S.C. § 2000d *et seq.*, 78 stat. 252), (prohibits discrimination on the basis of race, color, national origin); and 49 CFR Part 21.
- The Uniform Relocation Assistance and Real Property Acquisition Policies Act of 1970, (42 U.S.C. § 4601), (prohibits unfair treatment of persons displaced or whose property has been acquired because of Federal or Federal-aid programs and projects);
- Federal-Aid Highway Act of 1973, (23 U.S.C. § 324 *et seq.*), (prohibits discrimination on the basis of sex);
- Section 504 of the Rehabilitation Act of 1973, (29 U.S.C. § 794 *et seq.*), as amended, (prohibits discrimination on the basis of disability); and 49 CFR Part 27;
- The Age Discrimination Act of 1975, as amended, (42 U.S.C. § 6101 *et seq.*), (prohibits discrimination on the basis of age);
- Airport and Airway Improvement Act of 1982, (49 USC § 471, Section 47123), as amended, (prohibits discrimination based on race, creed, color, national origin, or sex);
- The Civil Rights Restoration Act of 1987, (PL 100-209), (Broadened the scope, coverage and applicability of Title VI of the Civil Rights Act of 1964, The Age Discrimination Act of 1975 and Section 504 of the Rehabilitation Act of 1973, by expanding the definition of the terms "programs or activities" to include all of the programs or activities of the Federal-aid recipients, sub-recipients and contractors, whether such programs or activities are Federally funded or not);
- Titles II and III of the Americans with Disabilities Act, which prohibit discrimination on the basis of disability in the operation of public entities, public and private transportation systems, places of public accommodation, and certain testing entities (42 U.S.C. §§ 12131-12189) as implemented by Department of Transportation regulations at 49 C.F.R. parts 37 and 38;
- The Federal Aviation Administration's Non-discrimination statute (49 U.S.C. § 47123) (prohibits discrimination on the basis of race, color, national origin, and sex);
- Executive Order 12898, Federal Actions to Address Environmental Justice in Minority Populations and Low-Income Populations, which ensures discrimination against minority populations by discouraging programs, policies, and activities with disproportionately high and adverse human health or environmental effects on minority and low-income populations;
- Executive Order 13166, Improving Access to Services for Persons with Limited English Proficiency, and resulting agency guidance, national origin discrimination includes discrimination because of limited English proficiency (LEP). To ensure compliance with Title VI, you must take reasonable steps to ensure that LEP persons have meaningful access to your programs (70 Fed. Reg. at 74087 to 74100);
- Title IX of the Education Amendments of 1972, as amended, which prohibits you from discriminating because of sex in education programs or activities (20 U.S.C. 1687 *et seq.*).

EXHIBIT F
DISADVANTAGED BUSINESS ENTERPRISE (DBE) REQUIREMENTS
(REV 04022018)

Exhibit F does not apply to this Grant Agreement because there is no ADOT provided federal funding.

EXHIBIT G
INSURANCE (RISK MANAGEMENT) REQUIREMENTS
For Projects that Include Construction
(Effective 02/22/2018)

Indemnification: To the fullest extent permitted by law, the RECIPIENT shall defend, indemnify, and hold harmless The State of Arizona, and its departments, agencies, boards, commissions, universities, Officers, officials, agents, and employees (hereinafter referred to as "Indemnatee") from and against any and all claims, actions, liabilities, damages, losses, or expenses (including court costs, attorneys' fees, and costs of claim processing, investigation and litigation) (hereinafter referred to as "Claims") for bodily injury or personal injury (including death), or loss or damage to tangible or intangible property caused, or alleged to be caused, in whole or in part, by the negligent or willful acts or omissions of the RECIPIENT or any of its owners, officers, directors, agents, employees or subcontractors. This indemnity includes any claim or amount arising out of or recovered under the Workers' Compensation Law or arising out of the failure of such RECIPIENT to conform to any federal, state, or local law, statute, ordinance, rule, regulation or court decree. It is the specific intention of the parties that the Indemnatee shall, in all instances, except for Claims arising solely from the willful acts or omissions of the Indemnatee, be indemnified by the RECIPIENT from and against any and all claims. It is agreed that the RECIPIENT will be responsible for primary loss investigation, defense and judgment costs where this indemnification is applicable. In consideration of the award of this contract, the RECIPIENT agrees to waive all rights of subrogation against the State of Arizona, its officers, officials, agents and employees for losses arising from the work performed by the RECIPIENT for the State of Arizona.

In addition, should a Recipient utilize a contractor(s) and subcontractor(s), the indemnification clause between the Recipient and its contractor(s) and subcontractor(s) shall include the indemnification clause above.

INSURANCE REVIEW: RECIPIENT must complete and sign the *ADOT ESP GRANT INSURANCE CHECKLIST* and submit to MPD Contracts with the required evidence of insurance or self-insurance. Upon submission of a completed and signed Checklist and evidence, MPD Contracts will submit to Risk Management for review. Risk Management will review for compliance and notify MPD Contracts of acceptance or deficiencies, which will then be communicated to the RECIPIENT.

Proper permits must be obtained to conduct business or work on ADOT's right of way when applicable.

Minimum insurance requirements applicable to RECIPIENT and Contractors:

Commercial General Liability (CGL) – Occurrence Form

Policy shall include bodily injury, property damage, and broad form contractual liability coverage.

- | | |
|---------------------------------------------|-------------|
| ● General Aggregate | \$2,000,000 |
| ● Products – Completed Operations Aggregate | \$2,000,000 |
| ● Personal and Advertising Injury | \$1,000,000 |
| ● Damage to Rented Premises | \$50,000 |
| ● Each Occurrence | \$1,000,000 |

Business Automobile Liability

Bodily Injury and Property Damage for any owned, hired, and/or non-owned automobiles used in the

performance of this Agreement.

- Combined Single Limit (CSL) \$1,000,000

Workers' Compensation and Employers' Liability

- Workers' Compensation Statutory
- Employers' Liability
 - Each Accident \$1,000,000
 - Disease – Each Employee \$1,000,000
 - Disease – Policy Limit \$1,000,000

1. As required by this written agreement, policies or evidence of self-insurance shall be endorsed to include the State of Arizona and the Arizona Department of Transportation as additional insured with respect to liability arising out of all activities performed by, or on behalf of the RECIPIENT. (Workers Compensation is exempt from this requirement)
2. Policies or evidence of self-insurance shall waive subrogation in favor of the State of Arizona and the Arizona Department of Transportation for losses arising from work performed by or on behalf of the RECIPIENT, as required by this written agreement.

Additional Insurance Requirements

The policies or evidence of self-insurance shall include, or be endorsed to include, as required by this written agreement, the following provisions:

1. RECIPIENT's policies or evidence of self-insurance, as applicable, shall stipulate that the insurance or self-insurance required under this Agreement shall be primary and that any insurance carried by the Department, its agents, officials, employees or the State of Arizona shall be excess and not contributory insurance, as provided by A.R.S. § 41-621 (E).
2. Insurance or self-insurance provided by the RECIPIENT shall not limit liability assumed under the indemnification provisions of this Contract.

Notice of Cancellation

Applicable to all insurance policies or coverage required within the Insurance Requirements of this Contract, RECIPIENT's insurance or self-insurance shall not be permitted to expire, be suspended, be canceled, or be materially changed for any reason without thirty (30) days prior written notice to the State of Arizona. Within two (2) business days of receipt, the RECIPIENT must provide notice to the State of Arizona if they receive notice of a policy that has been or will be suspended, canceled, materially changed for any reason, has expired, or will be expiring. Such notice shall be sent directly to the Department and shall be mailed, emailed, hand delivered or sent by facsimile transmission.

Acceptability of Insurers

RECIPIENT's insurance policies shall be placed with companies licensed in the State of Arizona or hold approved non-admitted status on the Arizona Department of Insurance List of Qualified Unauthorized Insurers. Insurers shall have an "A.M. Best" rating of not less than A- VII. The State of Arizona in no way

warrants that the above-required minimum insurer rating is sufficient to protect the Contractor from potential insurer insolvency.

Verification of Coverage

RECIPIENT shall furnish the State of Arizona with Certificates of Insurance (valid ACORD form or equivalent approved by the State of Arizona) with the required endorsements / relevant policy sections OR evidence of self-insurance to establish compliance with requirements herein. An authorized representative shall sign the Certificate(s) or evidence of self-insurance.

1. Certificates and endorsements/relevant policy sections, or evidence of self-insurance must be received by the State before work commences. The State's receipt of evidence of insurance or self-insurance that does not comply with this written agreement shall not waive or otherwise affect the requirements of this agreement.
2. Each insurance policy or self-insurance required by this Contract must be in effect at, or prior to, commencement of work under this Contract. Failure to maintain the insurance policies or self-insurance as required by this Contract, or to provide evidence of renewal, is a material breach of contract.
3. All certificates or evidence of self-insurance required by this Contract shall be sent directly to the Department. The State of Arizona project/contract number and project description shall be noted on the Certificate of Insurance or evidence of self-insurance. The State of Arizona reserves the right to require complete copies of all insurance policies required by this Contract at any time.

Contractors/Subcontractors

Recipient's Certificate(s) shall include all contractors/subcontractors as insured under its policies or Recipient shall be responsible for ensuring and/or verifying that all contractors/subcontractors have valid and collectable insurance as evidenced by the Certificates of Insurance and endorsements for each Contractor. **All coverage for contractors/subcontractors shall be subject to the minimum Insurance Requirements identified above.** The Department reserves the right to require, at any time throughout the life of this contract, proof from the Recipient that its contractors/subcontractors have the required coverage.

Approval and Modifications

ADOT, in consultation with State Risk Management, reserves the right to review or make modifications to the insurance limits, required coverage, or endorsements throughout the life of this contract, as deemed necessary. Such action will not require a formal Contract amendment but may be made by administrative action.

Exceptions

If the Recipient is/are a State of Arizona agency, board, commission, or university, none of the above shall apply.

EXHIBIT H
LANGUAGE MODIFICATIONS
for Tribes, Nations, and Native American Communities

Exhibit H does not apply to this Grant Agreement.



ADOT ESP GRANT INSURANCE CHECKLIST

INSTRUCTIONS/TIPS/INFORMATION TO EASE THE INSURANCE PROCESS

- As soon as possible, share this Checklist and the insurance requirements in your Agreement with your risk manager, insurance broker, or insurance agent
- Gather the documents described at each checkbox below (you must provide ADOT with a copy of each)
- Sign the Checklist, attach required documents, and submit by email to your ADOT Project Manager

CERTIFICATE OF INSURANCE (OR EVIDENCE OF SELF-INSURANCE)

Certificate of Insurance

OR

Evidence of self-insurance (include required additional insured, waiver, primary/non-contributory language)

Recipient Initials _____

**Certificate Holder should read: The State of Arizona or ADOT, 1324 N. 22nd Ave., Phoenix, AZ 85009*

COMMERCIAL GENERAL LIABILITY

Additional Insured endorsement form / policy section / self-insurance language for **Ongoing Operations**

Additional Insured endorsement form / policy section / self-insurance language for **Completed Operations**

Waiver of Subrogation endorsement form / policy section / self-insurance language

Primary and Non-Contributory endorsement form / policy section / self-insurance language

Recipient Initials _____

AUTO LIABILITY

Additional Insured endorsement form / policy section / self-insurance language

Waiver of Subrogation endorsement form / policy section / self-insurance language

Recipient Initials _____

WORKER'S COMPENSATION

Waiver of Subrogation endorsement form or self-insurance language

Recipient Initials 

Recipient Representative Signature: 

Date: 2/23/2021





Multimodal Planning

Douglas A. Ducey, Governor
John S. Halikowski, Director
Gregory Byres, Division Director

October 16, 2020

Jenny Torres
Economic Development Manager
City of San Luis
P.O. Box 1170
San Luis, AZ 85349

FY 2020 Economic Strength Project - Notice of Grant Acceptance

Dear Ms. Torres,

Thank you for allowing the Arizona Commerce Authority and the Arizona Department of Transportation the opportunity to work with you and your community on this project. Congratulations on your successful ESP application! To confirm your acceptance of the grant please fill out the information below and return to the Arizona Department of Transportation at your earliest convenience.

We will accept the grant and the accurate breakdown below.

\$500,000 EPS Grant

\$847,653 Matching Funds

\$1,347,653 Total Project Costs

We are no longer interested in pursuing this grant.

If there are any changes for the contact information, please let me know.

Please mail, FAX, or e-mail your acceptance to the:

Arizona Department of Transportation 206 S. 17th Ave. #320B, Phoenix, AZ 85007

FAX – 602-712-6412, E-mail: LungyoSugiyama@azdot.gov

If you have any questions, please contact Lynn Sugiyama at 602-712-6883.

Sincerely yours,

Lynn Sugiyama
Transportation Planner
Arizona Department of Transportation



Request for Grant Applications ACA Solicitation: 2020-21, First Amendment

Arizona Commerce Authority
100 N. 7th Avenue
Suite 400
Phoenix, AZ 85007
602-845-1200

NOTICE OF REQUEST FOR GRANT APPLICATIONS

Solicitation Number: 2020-21

Amendment Number: **First Amendment, April 28, 2020**

Solicitation Change(s): Changes to Questions Due Date, Q&A Release, Submission Due Date, and Pending Award Notification Date; added signed Amendment signature requirement.

Solicitation Type: Request for Grant Applications (RGA)

Solicitation Title: FY2020 Economic Strength Projects Grant ("ESP")

Solicitation Release Date: March 16, 2020

Original Questions Due Date: April 6, 2020 by 5:00 PM MST

Amended Questions Due Date: **May 12, 2020 by 5:00 PM MST**

Amended Q&A Release Date: **May 15, 2020 (tentative)**

Amended Submission Due Date: **June 11, 2020 by 4:30 PM MST**

Amended Pending Award Notification Date¹: **July 30, 2020 (tentative)**

Contract Term: Projects must be completed within 18-months from the effective date of the governing grant agreement.

Total Funding Amount: \$1,000,000

Solicitation Point of Contact: Teri Orman
Grants and Procurement Manager
(602) 845-1245
terio@azcommerce.com

ACA Authorized Representative:

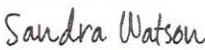
DocuSigned by:

4B489B061F82492...

Sandra Watson, President and CEO

All other provisions of the Solicitation shall remain in their entirety. Defined terms in the Solicitation have the same meaning in this amendment. A signed copy of this Amendment must be included in the RFP Response to be considered for evaluation.

VENDOR HERBY ACKNOWLEDGES RECEIPT AND UNDERSTANDING OF THE ABOVE AMENDMENT.

| | | | |
|-------------|-------------------------------------------------------------------------------------|--------|-----------|
| Signature |  | Date: | 6/11/2020 |
| Print Name: | Gerardo Sanchez | Title: | Mayor |

¹ Reference Section 4.1, Notice of Award, for further information.

ECONOMIC STRENGTH PROJECTS (ESP) APPLICATION FORM

Applicants are required to complete all fields, print, sign in ink, and include the original signed form with their Grant Application submission.

| APPLICANT INFORMATION | | | |
|------------------------------------------------------------------------------------------------------------------------------------------------------------------|-------------------------------------------------------------------------------------------------------------------------------------------------------------------|---------|----------------------------------------------------------------------|
| Entity Name | City of San Luis & Greater Yuma Port Authority | FEIN | 86-0376164 |
| Entity Type | <input checked="" type="checkbox"/> Arizona incorporated city or town with a population less than 150,000 and not contiguous with or situated within a Metro Area | | |
| | <input type="checkbox"/> Arizona county with a population less than 750,000 | | |
| | <input type="checkbox"/> Federally recognized Indian tribe situated in Arizona not contiguous to an urban area | | |
| Mailing Address | 1090 E. Union Street PO BOX 1170 San Luis, Arizona 85349 | Website | https://www.sanluisaz.gov/ |
| Application Contact: The contact person for clarifications and communications regarding the Grant Application. | | | |
| Name | Jenny Torres | Title | Economic Development Manager |
| Phone Number | (928)341-8584 | Email | jtorres@sanluisaz.gov |
| AWARD CONTACT INFORMATION | | | |
| Project Manager: Reviews Agreement content and starts signature process; responsible for managing project and tracking project. | | | |
| Name | Jenny Torres | Title | Economic Development Director |
| Phone Number | (928)341- | Email | bgeorge@gypa.org |
| Authorized Signatory: The contact person authorized to execute the Agreement, if awarded. | | | |
| Name | Gerardo Sanchez | Title | Mayor |
| Phone Number | (928)341-8520 | Email | gsanchez@sanluisaz.gov |
| Alternate Signatory: The alternate person authorized to sign on behalf of the Applicant in the absence of the principal authorized signatory named above. | | | |
| Name | Tadeo de la Hoya | Title | City Manager |
| Phone Number | (928)341-8520 | Email | tdelahoya@sanluisaz.gov |
| Legal: The person responsible for legal review of the Agreement. If unknown, this must be determined prior to Agreement execution. | | | |
| Name | Kay Macuil | Title | City Attorney |
| Phone Number | (928)341-9117 | Email | kmacuil@sanluisaz.gov |
| Records: Receives executed Agreement for official agency records and is the primary contact for the project. | | | |
| Name | Sonia Cornelio | Title | City Clerk |
| Phone Number | (928)341-8520 | Email | SCornelio@sanluisaz.gov |
| Accounting: Receives executed Agreement for funding and billing records; point of contact for questions on billing. | | | |
| Name | Monica Castro | Title | Finance Director |
| Phone Number | (928)341-8553 | Email | mcastro@sanluisaz.gov |

| PROJECT INFORMATION | | | |
|---------------------------------------------------------------------------------------------------------------------------------------------------------------------------------------------------------------------------------------------------------------------|----------------------------------------------------------------------------------------------------------------------------------------------------------------------------------------------------------------------------------------------------------------------------------------------------------------------------------------------------------------------------------------------------------------------------------------------------------------------------------------------------------------------------------------------------------------------------------------------------------------------------------------|------------------------------------------|--------------|
| Project Name | Gary Magrino Industrial Park Subdivision 3 | | |
| Brief Project Description | <p>The Greater Yuma Port Authority (GYPA) and the City of San Luis are requesting FY 2020 Economic Strength Project funds for a rural road construction project to continue development of the Gary J. Magrino Industrial Park located in San Luis, Arizona adjacent to the San Luis Port of Entry on the United States-Mexico border. This project consists of paving a designated public roadway in a newly platted subdivision of the park that has attracted several developers who will bring new jobs to the area and millions in capital investment contingent on the completion of the road construction by March of 2021.</p> | | |
| Name(s) and NAICS Code(s) of Direct Private Beneficiary(ies) | San Luis Trading & Logistics, LLC (493120) Labrie Properties, LLC (493110) RL Jones Insurance Services, Inc (524210) | | |
| Name(s) and NAICS Code(s) of Indirect Private Beneficiary(ies) | Franks Trucking (484110) Chilos Trucking (484110) Desert Runner Transportation, Inc (484110) | | |
| PROJECT BUDGET SUMMARY | | | |
| Total Eligible Project Costs | \$1,347,653.06 | Total Match for Eligible Costs | \$ 50,000.00 |
| Total Ineligible Project Costs | \$ 41,960.00 | Match % of Total Eligible Costs | 10% |
| Total Project Costs | \$1,389,613.06 | Total Other Funding for Ineligible Costs | \$847,653.06 |
| ESP Grant Funds Requested | \$ 500,000.00 | Total Project Funding | \$350,000.00 |
| PROJECTED PROJECT OUTCOMES (36 months after project completion) | | | |
| Number of New Jobs | 111 | | |
| Average Wage | \$15.00 | | |
| New Payroll | \$9,183,389.00 | | |
| % of Employer-Provided Healthcare Costs | | | |
| Capital Investment | \$31,500,000.00 | | |
| AFFIRMATION | | | |
| As the authorized representative of the Applicant, I certify under penalty of perjury that the information contained herein and attached hereto is true and correct according to the best of my knowledge and belief after a reasonable investigation of the facts. | | | |
| Authorized Representative | | | |
| Signature |  | Date | 6/11/2020 |
| Printed Name | Gerardo Sanchez | Title | Mayor |
| Co-sponsor (if applicable) | | | |
| Signature |  | Date | 06-10-2020 |
| Printed Name | Matias Rosales | Title | Chairman |

GARY J. MAGRINO INDUSTRIAL PARK PHASE 3 PROJECT

The Greater Yuma Port Authority, Inc. (GYPA) is a nonprofit corporation established in 2000 to serve as a cooperative regional effort of government entities within the Yuma County region to develop the new port district in San Luis and to ensure the economic wellness of the Yuma County region. Current members of the Authority include representatives of the Yuma County Government, Cocopah Indian Tribe, City of San Luis, and City of Yuma. Development of the Gary J. Magrino Industrial Park has occurred gradually through carefully designed phases to ensure steady growth. More infrastructure is needed to secure subsequent development in the park to reach its fullest potential. GYPA and the City of San Luis are seeking FY 2020 Economic Strength Project funds for a rural road construction project to overcome infrastructure limitations, attract capital investment, and generate new jobs.

Located in the heart of a megaregion composed of four states and two nations, Yuma County is the 3rd largest metropolitan area in Arizona with a population of 212,128. The county is composed of the Cities of Yuma, San Luis, Somerton and the Town of Wellton. Yuma County is the Southwest's premier agricultural hub and Winter Lettuce Capital of the world thanks to its location, sunny weather, and senior Colorado River water rights. While agriculture accounts for \$2.3 billion of Yuma's \$7.8 billion GDP, the economy is also supported through military and government services (\$1.7 billion), healthcare (\$500 million), retail services (\$700 million), professional services (\$450 million), and manufacturing (\$300 million). Yuma is home to two elite military installations: Marine Corps Air Station Yuma and Yuma Army Proving Ground that conduct extensive aviation and defense testing and attract talent from all over the world.

Yuma's unique location and assets allow for easy access to international markets and supply chains with the ability to deliver goods in a single day truck haul. The San Luis II Commercial Port of Entry is a unique, modern facility designed to use state of the art technology to facilitate commercial traffic and trade across the Arizona-Mexico border that is essential to the region's economy. Arizona is one of the top ten U.S. states to trade with Mexico. Manufacturing and agricultural goods account for most of the exports. In 2019, more than \$1.3 billion in import and export commodities flowed through the San Luis area alone, as well as 36,885 trucks. It is estimated that number will exceed 50,000 trucks in 2020. The existing San Luis Port of Entry could only off load two tractor trailers to inspect before running out of dock space, while the new San Luis II can handle up to twenty-five trailers at a time reducing long wait times and allowing more goods to pass through. Taking into consideration the volumes of produce and perishable products that make their way across the border, the value of efficient operations that accommodate the critical element of time to market is an essential part of the Port's operations. The new USMCA trade agreement is poised to provide more opportunities to increase Arizona's foreign trade market with Mexico and benefit the border economy. Doug Ducey, Governor of Arizona, also recognized future potential and committed a directive to expand binational commerce through Arizona's ports of entry.

A binational community has grown alongside the bustling port. The City of San Luis is one of the fastest growing communities in Yuma County. According to the U.S. Census Bureau statistics, the population doubled from approximately 15,000 residents in 2010 to more than 30,000 in 2017. San Luis experienced a 24% increase compared to Yuma County's 4% change for that time period. The city's population is projected to continue to increase exponentially to more than 70,000 people by 2040 with the help of the ports and the Magrino Industrial Park to promote healthy binational relations. When the San Luis II port opened, CBP was able to open a SENTRI

lane to expedite border crossing also used by individuals who come to San Luis to work, shop, or visit with family. The City of San Luis's economy is supported by the many residents from the border community of San Luis Rio Colorado in Mexico who regularly cross through the port to purchase local American goods.

The Wilson Center of the Mexico Institute reported San Luis Rio Colorado is home to 63 industries that provide more than 20,000 jobs. The Maquiladora, or Twin Plants, industry is growing fast and impacts the local economy. These factories located primarily close to the border use raw materials imported from abroad to produce commodities for export developed in "twin plants" on the U.S. side of the border. This industry program began more than 60 years ago to serve as a lower cost manufacturing alternative to China for multinational organizations. Yuma County and the City of San Luis benefit from maquiladora businesses. Roughly each maquiladora job results in two ancillary jobs in Mexico. A single maquiladora job potentially supports about nine people (including dependents) in Mexico who are likely to cross the border to shop or dine.

Since incorporation in 2000, GYPA has worked diligently to make necessary improvements to the port district and continues to look for more opportunities. After taking ownership and responsibility for approximately 240 acres of land adjacent to the San Luis II Port of Entry to develop, GYPA gave life to the Magrino Industrial Park to support trade through the port of entry. Its location so close to Interstate 8, Highway 95, the Mexico border, and ports of entry make it the ideal place to manufacture goods for export. In 2014, the park was undeveloped and in need of an access road to attract occupants. The San Luis Commercial Operations Management, L.L.C. (SLCOM) committed to purchasing a lot in the park that would lead to an investment of \$13 million dollars and 90 employees upon the completion of the construction.

GYPA flew into action to secure the necessary funding for the construction of the required infrastructure. GYPA committed matching funds to a Rural Economic Development Grant that were used to construct an interior roadway, County 25th Street, to secure the SLCOM development. The Yuma County Engineering Division went to bid and the project was completed within the designated eighteen month time frame in line with the City of San Luis' requirements. Not only did this project create jobs and develop much needed infrastructure, but also encouraged property owners surrounding the park to invest capital into their own land that helps attract more industries to the region.

More businesses followed SLCOM and purchased parcels in the Magrino Industrial Park. The Cocopah Tribe owns 26.7 acres. RL Jones Properties, a Customs Brokerage and International Logistics Company, currently owns 30.18 acres. Edy Lopez, Owner of Desert Runner Transportation purchased a 5.08-acre parcel as an expansion to his current operation that is currently based out of Nogales Arizona. San Luis Trading and Logistics purchased a 3.3737-acre parcel in September of 2019. At that time, they owned 10 acres but now own 13.54 acres and have begun construction on an expansion facility for Spindle Cooling & Warehousing who receive, ship, and streamline the movement of perishable goods. Cecilio Beltran of Chilos Trucking purchased 5.08 acres in January 2020. Franks Trucking owns 10.16 acres and currently operates out of the industrial park closer to San Luis I but hopes to expand to Magrino in the next few years.

GYPA still has 86.2893 acres to develop. The most recent unit of Magrino Industrial Park consists of 57.7465 acres currently zoned light industrial. The parcels sizes consist of 1-10.3327-acre parcels that is currently under option contract for purchase, 1- 5.6810-acre parcel that is already sold, 1-26.7-acre parcel that belongs to the Cocopah Tribe, 10-1.0028-acre

parcels. GYPA hopes to attract light and heavy industrial users to the unit. Commercial real estate agent Jerry Lococo of SVN Commercial Real Estate has been the listing agent since January of 2018 to attract investment activity in the park. The initial price point was at \$45,000 an acre and has now increased to \$50,000 an acre. There are currently more prospects in place than there are lots available with this new subdivision.

Originally, land use to the east side of Avenue D, the narrow portion of the property, was to accommodate a rail line. Upon further review and the current growth of the City of San Luis, GYPA realized a binational rail line would have to be located farther away from future residential districts. The smaller parcels were created to maximize the slender area to accommodate smaller enterprises that could support the service providers of its larger users such as: tire repair shops, mobile trucking service, mechanics, suppliers and/or the possibility of an overnight parking lot for trucks, contractors or any other type of micro enterprise. The goal is to encourage and provide businesses the opportunity to implement or expand that in turn leads to job creation and generating of revenue and consumerism. This goal falls directly into one of GYPA's main focus areas as expressed in their mission statement: to facilitate trade and enhance the economic development that will benefit the region.

San Luis's growing population provides access to a larger workforce in a centralized location also supplemented by Mexican Nationals who cross the border to work in Arizona. The Arizona Department of Administration reports San Luis has a labor force of 17,793 individuals, but 11,943 of those are currently unemployed. That means the area is experiencing a 67.1% unemployment rate and is in dire need of projects that lead to direct job growth. GYPA's proposed infrastructure construction project will not only benefit the park but provide the community with the creation of much needed jobs.

Project Description and Timeline – Improvements

This project consists of paving approximately 3320 LF of 57 feet wide dedicated public roadway in Magrino Industrial Park Unit No. 3. This roadway can be described as having a 54-foot-wide section of asphalt with ribbon curb at both edges. This newly platted subdivision will have 13 lots zoned "Heavy Industrial". Project work also includes construction of a box culvert over the 242 Irrigation/Drainage Lateral that will provide secondary access to the subdivision. The project will expand available industrial parcel options adjacent to the San Luis Commercial Port of Entry. One lot has already been sold and another lot is under option to purchase. After going to bid for a contractor, the construction project will take an estimated five months to complete.

Core Engineering Group calculated the total estimated cost for this construction project is \$1.3 million dollars. As a non-profit organization with limited resources, GYPA is applying for ESP grant funds in the amount of \$500,000 to fulfill Phase 3 of the Magrino Industrial Park development. GYPA has secured a 10% cash match in the amount of \$50,000 committed to the cost of construction, available as needed and is not or will not be conditioned or encumbered in any way that would preclude its use consistent with the requirements of the investment opportunity, and plans to reinvest more than \$300,000 in sales proceeds from the park towards making this project come to fruition. GYPA is also pursuing United States Economic Development Administration CARES Act grant funds to help offset costs since this project will help mitigate COVID-19 related economic injuries to the Yuma County population through millions of dollars in capital investment and job creation. GYPA has already taken several

essential steps to get the ball rolling on this project. Design of the construct is complete, a Bureau of Reclamation permit is in place, and the site is shovel ready with no expected delays. It is imperative GYPA secures this funding opportunity to begin construction as soon as possible to honor their commitment to have the project completed by March 2021 for the new users to begin development, otherwise the park will have to attract new investors.



Project Description and Timeline – Development Matters

The San Luis Trading and Logistics, L.L.C. has three projects contingent on the completion of construction that will lead to an estimated \$10.7 million in total capital investment and 22 employees with average wages of \$15-\$16 dollars an hour. These projects are expected to be completed within a year. Labrie Properties, L.L.C. is a warehousing and light manufacturing company looking to develop a facility to support an existing facility in Mexico that has operated in San Luis Rio Colorado for over twenty years and employs 250 people. Labrie Properties plans to invest \$4 million for the project that will 35 employees at \$15 an hour. RL Jones is finalizing the engineering of a 42,000 square foot warehouse that will be completed within a year and will need to hire approximately 19 employees. At minimum, this project will lead to the creation of 111 jobs with an average wage of \$15.00 an hour that will be 250% higher than the current per capita income of \$12,913 in San Luis.

| Economic Impact Summary | | | | | | |
|--------------------------------|-----------------------------------------------------|------------------------|-----------------------------|--------------------------------|--------------|-----------------------------|
| Year | Total Capital Investment (Construction & Equipment) | Total New Jobs Created | Total New Payroll Supported | Square Footage of Construction | Land Cost | Total Value Economic Impact |
| 2020 | \$31,500,000 | 111 | \$2,830,282 | 193,069 | \$221,612.72 | \$9,061,155 |

Source: *Applied Economics* (Attached)

This proposed project is more important than ever in lieu of the COVID-19 pandemic's effects on the local economy. The City of San Luis estimates a reduction of 30% of revenues for the last quarter of the fiscal year and the first quarter of the following fiscal year beginning in July of 2020. The City of San Luis does not have a property tax and depends on the Mexican shopper for sales tax revenue who accounts for 70% of sales tax revenue. Due to COVID-19, restriction of essential vs. non-essential travel and reduction of crossing lanes, people are waiting up to five hours in line to cross the border. CBP reported a reduction of 14% in crossings. This is a significant loss on top of impacts from the recent immigration crisis. US custom agents are being sent to Texas to assist border patrol reducing the already limited number of staff at the port of entry. Therefore, the immigration issue and the pandemic has negatively impacted the surrounding community. It is expected the percent will decrease, but the true long-lasting impact of COVID-19 is unknown. This project has the potential to offset some of the damage and introduce new capital investment to the region.

PROJECT BUDGET

| COSTS | | | | | |
|-----------------------------------------------------|---------------------------------------------------------|-----------------|-------------|-----------------------|------------------------|
| ELIBIBLE ESP PROJECT COSTS | | | | | |
| Section A: DOMESTIC WATER SYSTEM | | | | | |
| Bid Item | Description | Quantity | Unit | Unit Cost (\$) | Total Cost (\$) |
| 1. | 1" Water Meter, Box, and Service | 13 | EA | \$ 828.00 | 10,764.00 |
| 2. | 6" Fire Hydrants (Street Markers by Surface Contractor) | 9 | EA | \$ 4,000.00 | 36,000.00 |
| 3. | 6" Class 150 C-900 Water Line | 674 | LF | \$ 18.00 | 12,132.00 |
| 4. | 12" Class 150 C-900 Water Line | 2,310 | LF | \$ 25.00 | 57,750.00 |
| 5. | 6" Valve | 18 | EA | \$ 1,080.00 | 19,440.00 |
| 6. | 12" Valve | 8 | EA | \$ 3,200.00 | 25,600.00 |
| 7. | Connect New 12" Waterline to Existing | 2 | EA | \$ 3,490.00 | 6,980.00 |
| 8. | Blind Flange and Thrust Block | 13 | EA | \$ 885.00 | 11,505.00 |
| 9. | Blow-off Valve | 2 | EA | \$ 500.00 | 1,000.00 |
| | Subtotal: | | | | \$181,171.00 |
| Section B: SANITARY SEWER SYSTEM | | | | | |
| Bid Item | Description | Quantity | Unit | Unit Cost (\$) | Total Cost (\$) |
| 10. | 4' Dia. Manhole (0 to 13.5 deep) | 1 | EA | \$ 10,700.00 | 10,700.00 |
| 11. | 6" SDR35 PVC Sewer (LOT SERVICE) | 828 | LF | \$ 26.00 | 21,528.00 |
| 12. | 10" SDR35 PVC Sewer | 2,521 | LF | \$ 42.00 | 105,882.00 |
| 13. | 8" SDR35 PVC Sewer | 0 | LF | \$ 109.00 | 0.00 |
| 14. | 5' Dia. Manhole (13.5 to 26.5 deep) | 4 | EA | \$ 17,425.00 | 69,700.00 |
| 15. | Type 'B' Drop Sewer Connection | 1 | EA | \$ 1,760.00 | 1,760.00 |
| | Subtotal: | | | | \$209,570.00 |
| Section C: UTILITY COMPANY REQUIREMENTS | | | | | |
| Item | Description | Quantity | Unit | Unit Cost (\$) | Total Cost (\$) |
| 20. | (2) 4" Schedule 40 Conduit - CLink in APS trench | 3,060 | LF | \$ 10.70 | 32,742.00 |
| 21. | (2) 4" Schedule 40 Conduit - CenturyLink | 0 | LF | \$ 5.50 | 0.00 |
| 22. | (3) APS 2" Conduit - DB120 or Equal | 80 | LF | \$ 9.70 | 776.00 |
| 23. | APS 2.5" Conduit - DB120 or Equal | 0 | LF | \$ 4.40 | 0.00 |
| 24. | APS (2) 5" Conduit - DB100 or Equal | 3,060 | LF | \$ 11.00 | 33,660.00 |
| 25. | APS 5" Conduit - DB100 or Equal | 0 | LF | \$ 8.00 | 0.00 |
| 26. | SWGAs Sleeves | 200 | LF | \$ 20.00 | 4,000.00 |
| 27. | Street Lights | 14 | EA | 2,700.00 | 37,800.00 |
| 28. | APS Infrastructure Charges | | TBD | | |
| | Subtotal | | | | \$108,978.00 |
| Section D: CONSTRUCTION STAKING | | | | | |
| | Description | Quantity | Unit | Unit Cost (\$) | Total Cost (\$) |
| | Survey Crew - Utility only | 1 | LS | 10,000.00 | 10,000.00 |
| | Subtotal | | | | |
| TOTAL Sections A, B, C and D (UNDERGROUND) = | | | | \$509,719.00 | |

| SECTION E: SURFACE WORK | | | | | |
|--------------------------------|--------------------------------------|-----------------|-------------|-----------------------|------------------------|
| Bid Item | Description | Quantity | Unit | Unit Cost (\$) | Total Cost (\$) |
| 31. | Subgrade Prep. | 20,049 | SY | 3.00 | 60,147.92 |
| 32. | 3" Asphalt Concrete | 3,316 | Ton | 91.00 | 301,724.52 |
| 33. | 8" ABC | 4,455 | CY | 36.00 | 160,394.45 |
| 34. | 8" ABC Roadway | 259 | CY | 36.00 | 9,312.89 |
| 35. | Ribbon Curb | 6,395 | LF | 8.00 | 51,160.00 |
| 36. | Vertical Curb and Gutter | 178 | LF | 10.00 | 1,780.00 |
| 37. | Curb Transitions | 4 | EA | 50.00 | 200.00 |
| 38. | Concrete Driveway (BOR Access Roads) | 640 | SF | 6.00 | 3,840.00 |
| 39. | 4-015 Subdivision Monuments | 13 | EA | 400.00 | 5,200.00 |
| 40. | 4-030 (Type B) Street Monuments | 2 | EA | 110.00 | 220.00 |
| 41. | Street Name Sign with Stop Sign | 1 | EA | 440.00 | 440.00 |
| 42. | Type III Baricade | 96 | LF | 205.00 | 19,680.00 |
| 43. | 48" RGRCP ClassIII | 80 | LF | 200.00 | 16,000.00 |
| 44. | Box Culvert 5' x 6' | 80 | LF | 605.00 | 48,400.00 |
| 45. | Headwalls | 2 | EA | 8,000.00 | 16,000.00 |
| 46. | 24" Thermoplastic Stop Bar | 35 | LF | 12.00 | 420.00 |
| 47. | Water Valve Box Installation | 18 | EA | 300.00 | 5,400.00 |
| 48. | Hydrant Markers | 7 | EA | 12.00 | 84.00 |
| TOTAL ESTIMATED COST | | | | | \$700,403.78 |

CONSTRUCTION STAKING

| Item | Description | Quantity | Unit | Unit Cost (\$) | Total Cost (\$) |
|----------------------------------------------|----------------------------|-----------------|-------------|-----------------------|------------------------|
| 50. | Survey Crew - Roadway Work | 1 | LS | 15,000.00 | 15,000.00 |
| TOTAL ESTIMATED COST | | | | | \$15,000.00 |
| REMAINING ESTIMATED CONSTRUCTION COST | | | | | \$15,000.00 |

| | |
|---------------------------------------------------------------|------------------|
| TOTAL ESTIMATED DEVELOPMENT SURFACE CONSTRUCTION COSTS | \$715,404 |
|---------------------------------------------------------------|------------------|

| | |
|------------------------------------------------------------------|-----------------------|
| SUBTOTAL ESTIMATED CONSTRUCTION COSTS (SHEET 1 + SHEET 2) | \$1,225,123 |
| CONTINGENCY | 10% |
| TOTAL ESTIMATED CONSTRUCTION COSTS + CONTINGENCY | \$1,347,635.06 |

OTHERE COSTS INELIGIBLE FOR ESP REIMBURMENT

| Description | Total Cost (\$) |
|-----------------------------------------|------------------------|
| Contracted Engineer Assessment of Costs | \$41,960.00 |

| FUNDING | BUDGET |
|-----------------------------------------------------------------|---------------------|
| ESP Funds Requested for Cost Reimbursements | \$500,000.00 |
| Match Contributions | |
| Greater Yuma Port Authority (GYPA) | \$308,040.00 |
| EDA Care Grant Funds | \$ (TBD) |
| Total Match Contributions | \$308,040.00 |
| Match Percent of Total Eligible ESP Project Costs | 61% |
| Other Funding for Costs Ineligible for ESP Reimbursement | |
| Greater Yuma Port Authority (GYPA) | \$ 41,960.00 |
| Total Funding for Ineligible Costs | \$ 41,960.00 |

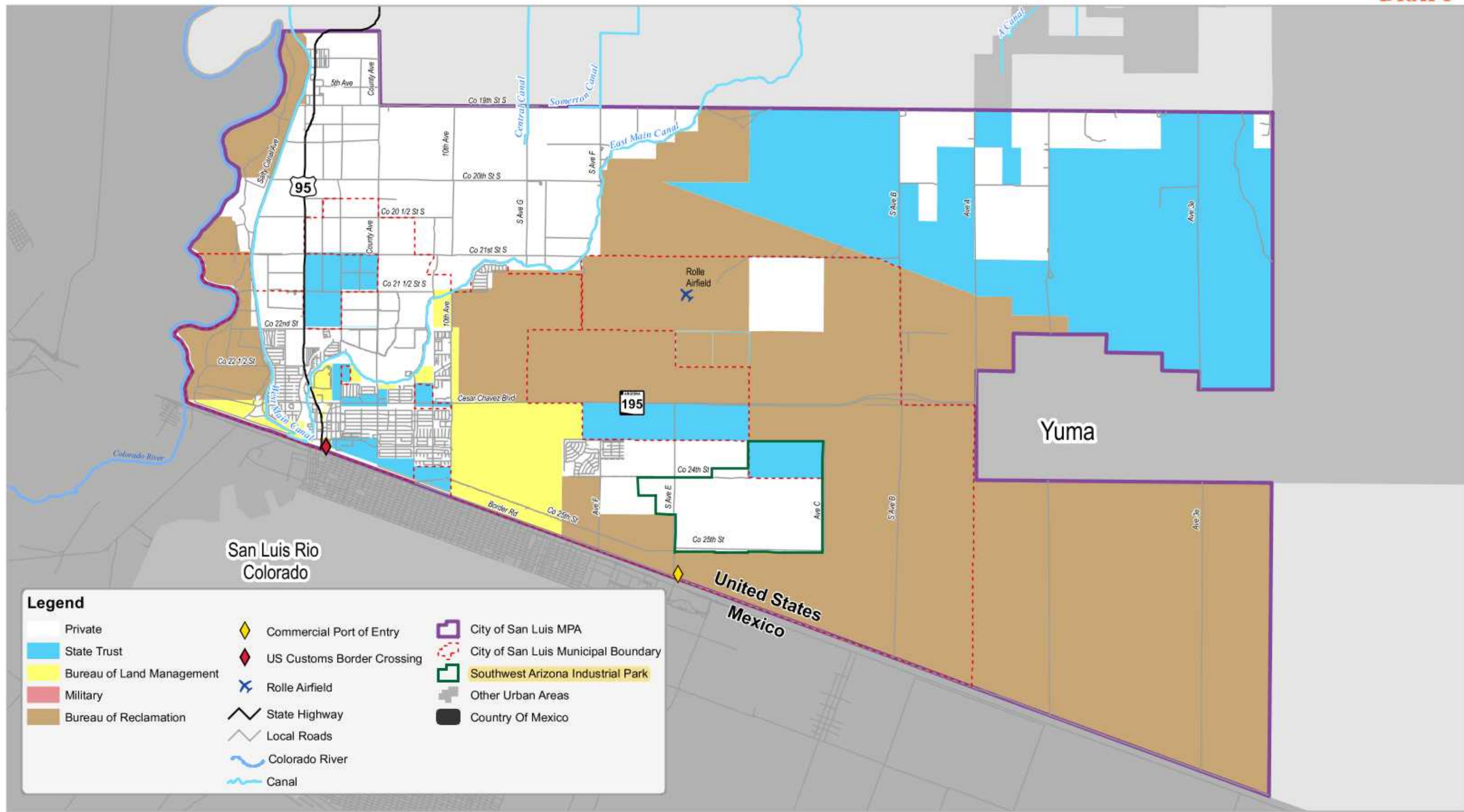

Legend

| | | |
|---------------------------|----------------------------|-------------------------------------|
| Private | Commercial Port of Entry | City of San Luis MPA |
| State Trust | US Customs Border Crossing | City of San Luis Municipal Boundary |
| Bureau of Land Management | Rolle Airfield | Southwest Arizona Industrial Park |
| Military | State Highway | Other Urban Areas |
| Bureau of Reclamation | Local Roads | Country Of Mexico |
| | Colorado River | |
| | Canal | |



Source: Carlos Efraín Porto Tapiquén, Orogénesis Soluciones Geográficas, USGS, U.S. Census, OpenStreetMaps, geofabrik.de

Figure 2-1

Land Ownership

SAN LUIS INDUSTRIAL PARK, LLC
412 Henry Chavez Ct.
P.O. Box 3660
San Luis, AZ 85349
(928) 920-2712

June 10, 2020

Teri Orman
Grants and Procurement Manager
Arizona Commerce Authority
100 N 7th Avenue Suite 400
Phoenix, AZ 85007

Dear Ms. Orman,

As Chairman for San Luis Industrial Park, LLC, I am writing you in support of the Economic Strength Program grant application in the amount of \$500,000 for the continued development of the Magrino Industrial Park as submitted by the City of San Luis and the Greater Yuma Port Authority. This industrial park has served as a gateway for those who facilitate trade between the United States and Mexico and has enhanced the region's economic development, providing employment and strengthening the relationship with our partners in Mexico.

A key deliverable of this project would be the continued expansion in utilization of the San Luis II Land Based Port of Entry. At this time, the port is underutilized and has room for growth and to accommodate higher volumes of trucks. To appeal to future users, the Magrino Industrial Park will be able to provide businesses a strategically placed base of operation at the border, which aligns with City of San Luis's mission of being a business friendly city.

Yuma County has for many years suffered from high unemployment, low per capita income, and low educational attainment. Economic challenges have become even more acute since the significant job losses that have been suffered locally due to COVID-19, most significantly felt in lower wage earning jobs.

I express my strong support for this project. Industrial development can and will be the key to combating unemployment and will help bring higher wage earning jobs to the area which will benefit the entire Yuma County region.

Should you have any questions or concerns, please do not hesitate to contact me.

Sincerely,

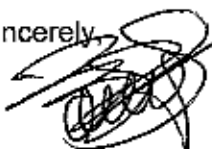

Mario S. Jauregui, Chairman
San Luis Industrial Park, LLC



City of San Luis

P.O. Box 1170
1090 E. Union Street
San Luis, AZ 85349-1170
Phone (928) 341-8520 • Fax (928) 341-8539
www.cityofsanluis.org

June 10, 2020

Teri Orman
Grants and Procurement Manager
Arizona Commerce Authority
100 N 7th Avenue Suite 400
Phoenix, AZ 85007

Dear Ms. Orman,

The City of San Luis entered into an intergovernmental agreement for joint operations of the Greater Yuma Port Authority along with the City of Somerton, Cocopah Tribe and County of Yuma in August of 2000. The City of San Luis along with other municipalities continue to support and contribute funding for the operations of the port authority and economic development activities that improves our economic conditions of our region.

The City of San Luis is partnering with the Greater Yuma Port Authority in applying for the Economic Strength Program grant application in the amount of \$500,000 for the continued development of the Magrino Industrial Park. This industrial park has served as a gateway for those who facilitate trade between the United States and Mexico and has enhanced the region's economic development, providing employment and strengthening the relationship with our partners in Mexico.

The City of San Luis continues to support public-private partnership to assist in the development of infrastructure required to provide opportunities for the region. As a border community, we are faced with unique challenges in dealing with high unemployment rate, low per capital income and educational attainment. The COVID-19 pandemic has brought additional challenges making it more difficult to improve the economic development conditions of our community.

The City of San Luis is currently working with the GYPA to enter into a contract to manage the grant. Under the current circumstance, the City's legal counsel and staff are facing an unprecedented situation and have been focused on dealing with COVID-19 issues. The City of San Luis is scheduled to present the contract to council on the June 24th council meeting for final approval.

The City of San Luis strongly supports the project and believe the grant funding will be able to support our struggle with improving our economic situation for San Luis and the entire Yuma County region.

Sincerely,

Gerardo Sanchez
Mayor



June 10, 2020

Teri Orman
Grants and Procurement
Manager Arizona Commerce
Authority
100 N 7th Avenue Suite 400
Phoenix, AZ 85007

Dear Teri Orman,

The Greater Yuma Port Authority is dedicated to developing the Gary J. Magrino Industrial Park to its fullest potential through any means. As GYPA, I am writing to express my full support of the FY2020 Economic Strength Projects (ESP) Grant application and will cooperate with all Arizona Commerce Authority regulations in accordance with approval. To demonstrate our commitment GYPA, with full support of all board members from Yuma County, City of Yuma, City of San Luis, and the Cocopah Tribe, will match 10% of grant funds in the amount of \$50,000 towards the rural road construction project costs. The funds available as needed and is not or will not be conditioned or encumbered in any way that would preclude its use consistent with the requirements of the investment opportunity.

Thank you for your time and consideration,

A handwritten signature in black ink, appearing to read "Matias Rosales", is written over a thin horizontal line.

Matias Rosales

GYPA Chairman

matias@realtynegroupgateway.com

928-304-2447

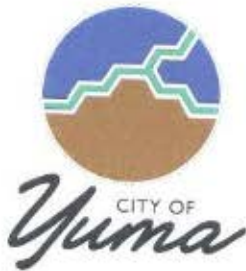

Mayor and Council Offices

One City Plaza
Yuma, Arizona 85364

(928) 373-5002
Fax (928) 373-5004
www.YumaAZ.gov

June 10, 2020

Teri Orman
Grants and Procurement Manager
Arizona Commerce Authority
100 N 7th Avenue Suite 400
Phoenix, AZ 85007

Dear Ms. Orman,

As a City Councilman for the City of Yuma, I am writing you in support of the Economic Strength Program grant application in the amount of \$500,000 for the continued development of the Magrino Industrial Park as submitted by the City of San Luis and the Greater Yuma Port Authority. This industrial park has served as a gateway for those who facilitate trade between the United States and Mexico and has enhanced the region's economic development, providing employment and strengthening the relationship with our partners in Mexico.

A key deliverable of this project would be the continued expansion in utilization of the San Luis II Commercial Land Based Port of Entry. At this time, the port is underutilized and has room for growth to accommodate higher volumes of trucks. To appeal to future users, the Magrino Industrial Park will be able to provide businesses a strategically placed base of operation at the border, which aligns with City of San Luis's mission of being a business friendly city.

Yuma County has for many years suffered from high unemployment, low per capita income, and low educational attainment. Economic challenges have become even more acute since the significant job losses that have been suffered locally due to COVID-19, most significantly felt in lower wage earning jobs.

I express my strong support for this project. Industrial development and international trade can and will be the key to combating unemployment helping to bring higher wage earning jobs to the area which will benefit the entire Yuma County region.

Sincerely,

Gary Knight
Council Member
City of Yuma



June 10, 2020

Teri Orman
Grants and Procurement Manager
Arizona Commerce Authority
100 N 7th Avenue Suite 400
Phoenix, AZ 85007

Dear Ms. Orman,

As Vice President of Acquisitions for Labrie Properties, LLC I am writing you in support of the Economic Strength Program grant application in the amount of \$500,000 for the continued development of the Magrino Industrial Park as submitted by the City of San Luis and the Greater Yuma Port Authority. This industrial park has served as a gateway for those who facilitate trade between the United States and Mexico and has enhanced the region's economic development, providing employment and strengthening the relationship with our partners in Mexico.

A key deliverable of this project would be the continued expansion in utilization of the San Luis II Land Based Port of Entry. At this time, the port is underutilized and has room for growth and to accommodate higher volumes of trucks. To appeal to future users, the Magrino Industrial Park will be able to provide businesses a strategically placed base of operation at the border, which aligns with City of San Luis's mission of being a business friendly city.

Yuma County has for many years suffered from high unemployment, low per capita income, and low educational attainment. Economic challenges have become even more acute since the significant job losses that have been suffered locally due to COVID-19, most significantly felt in lower wage earning jobs.

I express my strong support for this project. Industrial development can and will be the key to combating unemployment and will help bring higher wage earning jobs to the area which will benefit the entire Yuma County region. Labrie is constructing an 80,000 SF logistics and assembly building at the Magrino Industrial Park and will be hiring many local employees to staff the facility. The location is a key support facility for our manufacturing operation just across the border in San Luis Rio Colorado, Mexico.

Sincerely,

A handwritten signature in blue ink, appearing to read "Barnett Rogers", is written over a light blue horizontal line.

Barnett Rogers
Vice President of Acquisitions



**Franks Trucking
435 N Cesar Chavez
San Luis, AZ 85349**

June 10, 2020

Teri Orman
Grants and Procurement Manager
Arizona Commerce Authority
100 N 7th Avenue Suite 400
Phoenix, AZ 85007

Dear Ms. Orman,

As owner of Franks Trucking, I am writing you in support of the Economic Strength Program grant application in the amount of \$500,000 for the continued development of the Magrino Industrial Park as submitted by the City of San Luis and the Greater Yuma Port Authority. This industrial park has served as a gateway for those who facilitate trade between the United States and Mexico and has enhanced the region's economic development, providing employment and strengthening the relationship with our partners in Mexico.

A key deliverable of this project would be the continued expansion in utilization of the San Luis II Land Based Port of Entry. At this time, the port is underutilized and has room for growth and to accommodate higher volumes of trucks. To appeal to future users, the Magrino Industrial Park will be able to provide businesses a strategically placed base of operation at the border, which aligns with City of San Luis's mission of being a business friendly city.

Yuma County has for many years suffered from high unemployment, low per capita income, and low educational attainment. Economic challenges have become even more acute since the significant job losses that have been suffered locally due to COVID-19, most significantly felt in lower wage earning jobs.

I express my strong support for this project. Industrial development can and will be the key to combating unemployment and will help bring higher wage earning jobs to the area which will benefit the entire Yuma County region.

Sincerely,

 dotloop verified
06/10/20 2:12 PM MST
CLWG-HVBL-RTYV-EDOP

Frank Rascon
Owner, Franks Trucking

**OFFICE OF THE
BOARD OF SUPERVISORS**
198 Main Street
Yuma, Arizona 85364

SUSAN K. THORPE
COUNTY ADMINISTRATOR
CLERK OF THE BOARD



MARTIN PORCHAS
DISTRICT 1
RUSSELL McCLOUD
DISTRICT 2
DARREN SIMMONS
DISTRICT 3
MARCO A. (TONY) REYES
DISTRICT 4
LYNNE PAN CRAZI
DISTRICT 5

June 10, 2020

Teri Orman
Grants and Procurement Manager
Arizona Commerce Authority
100 N 7th Avenue Suite 400
Phoenix, AZ 85007

Dear Ms. Orman,

As the County Administrator for Yuma County, I am writing you in support of the Economic Strength Program grant application in the amount of \$500,000 for the continued development of the Magrino Industrial Park as submitted by the City of San Luis and the Greater Yuma Port Authority. This industrial park has served as a gateway for those who facilitate trade between the United States and Mexico and has enhanced the region's economic development, providing employment and strengthening the relationship with our partners in Mexico.

A key deliverable of this project would be the continued expansion in utilization of the San Luis II Land Based Port of Entry. At this time, the port is underutilized and has room for growth and to accommodate higher volumes of trucks. To appeal to future users, the Magrino Industrial Park will be able to provide businesses a strategically placed base of operation at the border, which aligns with City of San Luis's mission of being a business friendly city.

Yuma County has for many years suffered from high unemployment, low per capita income, and low educational attainment. Economic challenges have become even more acute since the significant job losses that have been suffered locally due to COVID-19, most significantly felt in lower wage earning jobs.

I express my strong support for this project. Industrial development can and will be the key to combating unemployment and will help bring higher wage earning jobs to the area which will benefit the entire Yuma County region.

Sincerely,

A handwritten signature in blue ink that reads "Susan Thorpe".

Susan K. Thorpe
Yuma County Administrator

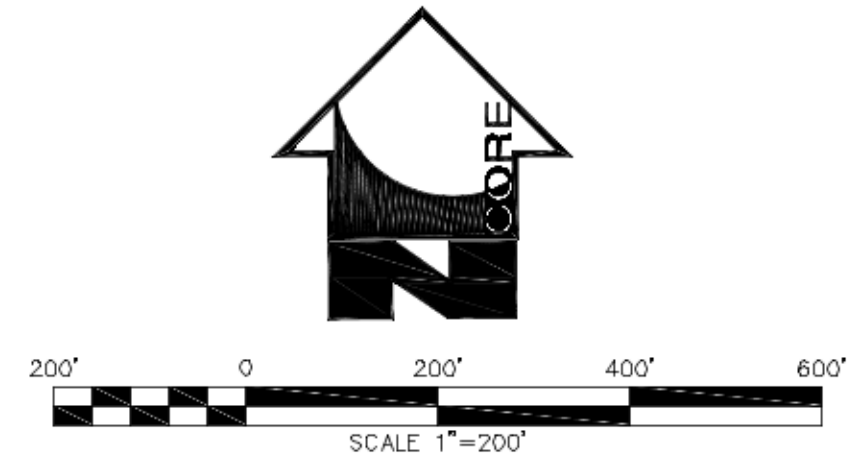

INDEX OF DRAWINGS

- 1 COVER SHEET
- 2-5 ROADWAY PLAN
- 6-7 PAVING AND GRADING DETAILS
- 8-15 WATER AND SEWER PLAN AND PROFILES
- 16 STORM WATER POLLUTION PREVENTION PLAN

GENERAL NOTES

1. ROADWAY CONSTRUCTION AND OTHER CONSTRUCTION AS SHOWN WILL CONFORM TO CITY OF SAN LUIS STANDARDS (CITY OF YUMA STANDARD DETAILS, MAG SPECIFICATIONS AND CITY OF SAN LUIS SUPPLEMENT) OR AS MODIFIED ON THESE PLANS UNLESS OTHERWISE NOTED OR SPECIFICALLY ALTERED/MODIFIED BY CITY OF SAN LUIS ORDINANCE. ALL UNDERGROUND UTILITY CONSTRUCTION WILL CONFORM TO CITY OF YUMA STANDARDS AND SPECIFICATIONS. THESE SPECIFICATIONS ARE INCLUDED HERE BY REFERENCE.
2. IT IS THE RESPONSIBILITY OF THE CONTRACTOR TO CONSTRUCT THE WORK IN ACCORDANCE WITH THE APPROVED PLANS AND SPECIFICATIONS. ALL WORK SHALL BE COMPLETED IN A THOROUGH MANNER, FREE OF ANY WORKMANSHIP DEFECTS. THE CONTRACTOR SHALL INFORM THE ENGINEER OF ANY DISCREPANCIES OR CONDITIONS REQUIRING CHANGE TO THE PLANS AND REQUEST INSTRUCTIONS BEFORE PROCEEDING WITH THE WORK.
3. ANY DEFECTIVE MATERIAL OR WORKMANSHIP SHALL BE REPLACED AND/OR REPAIRED PRIOR TO FINAL ACCEPTANCE OF THE WORK.
4. PRIOR TO THE COMMENCEMENT OF ANY CONSTRUCTION, THE CONTRACTOR SHALL PROVIDE THE ENGINEER WITH ALL PROPOSED PROJECT MATERIAL DATA SHEETS AND ANY SHOP DRAWINGS. ANY MATERIAL SUPPLIED NOT IN CONFORMANCE WITH THE SPECIFICATIONS WILL BE REJECTED.
5. THE CONTRACTOR WILL BE RESPONSIBLE, IN ACCORDANCE WITH ARIZONA REVISED STATUTES, TO NOTIFY THE ARIZONA BLUE STAKE CENTER AT (800) 782-5348 AT LEAST FORTY-EIGHT (48) HOURS IN ADVANCE OF COMMENCING CONSTRUCTION ACTIVITIES. LOCATIONS OF EXISTING PUBLIC UTILITY LINES SHOWN ON THE PLANS ARE APPROXIMATE. THE CONTRACTOR MUST VERIFY THE LOCATIONS IN THE FIELD AND TAKE NECESSARY PRECAUTIONS. ANY DAMAGE TO A UTILITY SHALL BE REPAIRED AT THE EXPENSE OF THE CONTRACTOR.
6. THE CONTRACTOR SHALL MAINTAIN DUST ABATEMENT ACTIVITIES FOR THE DURATION OF THE PROJECT, INCLUDING WEEKENDS AND HOLIDAYS TO CONFORM WITH APPLICABLE ADEQ REGULATIONS. THE CONTRACTOR SHALL MAINTAIN ADEQUATE MOISTURE LEVELS IN THE SURFACE MATERIALS TO ELIMINATE BLOWING DUST FROM THESE MATERIALS. ALL HAUL TRUCKS, WHETHER INVOLVED IN DELIVERY OR REMOVAL ACTIVITIES, SHALL BE COVERED AND/OR TARPED IN ORDER TO NEGATE THE REMOVAL OF MATERIAL FROM TRUCKS BY WINDS, EITHER NATURAL OR CAUSED BY THE MOVEMENT OF THE TRUCK.
7. THE CONTRACTOR WILL BE RESPONSIBLE FOR PROVIDING AND MAINTAINING PROPER SIGNS, BARRICADES, AND WARNING LIGHTS TO CONTROL THE TRAFFIC AND TO ASSURE THE PUBLIC'S HEALTH, WELFARE, AND SAFETY. ALL TRAFFIC CONTROL DEVICES MUST CONFORM TO THE MANUAL OF UNIFORM TRAFFIC CONTROL DEVICES. THE CONTRACTOR SHALL BE RESPONSIBLE FOR THE INSPECTION OF ALL TRAFFIC CONTROL INSTALLATIONS USED IN CONJUNCTION WITH THIS PROJECT AND SHALL INSPECT, AT LEAST TWICE DAILY, TO ENSURE CONFORMANCE WITH THE APPROVED TRAFFIC CONTROL PLAN.
8. THE CONTRACTOR WILL BE RESPONSIBLE FOR THE PREPARATION AND FURNISHING OF "AS-BUILT" RECORD DRAWINGS. THE "AS-BUILT" INFORMATION SHALL BE RECORDED ON THE PLANS IN RED COLORED PENCIL. THIS INFORMATION SHALL INCLUDE ALL CASES WHERE ACTUAL FIELD CONSTRUCTION DIFFERS FROM THE DESIGNED INFORMATION, ALL CONCEALED WORK, ALL UTILITY LOCATIONS, ALL WATER VALVES AND MANHOLES. DIMENSIONS SHALL BE SHOWN FROM KNOWN REFERENCE POINTS.
9. OCCUPATIONAL SAFETY AND HEALTH ACT (OSHA) STANDARD FOR CONSTRUCTION (TITLE 29, CODE OF FEDERAL REGULATIONS, PART 1926 AS AMENDED) AND CITY OF SAN LUIS SAFETY REGULATIONS ARE APPLICABLE FOR THE COMPLETION OF THE WORK ON THIS PROJECT.
10. THE CONTRACTOR SHALL OBTAIN ENCROACHMENT PERMITS FROM THE CITY OF SAN LUIS PRIOR TO THE COMMENCEMENT OF ANY WORK IN PUBLIC RIGHT-OF-WAY.
11. THE CONTRACTOR SHALL GUARANTEE THE WORK COMPLETED AGAINST DEFECTIVE MATERIAL AND/OR WORKMANSHIP FOR A PERIOD OF ONE (1) YEAR FROM THE DATE OF FINAL ACCEPTANCE GRANTED BY YUMA COUNTY.
12. GYPA WILL BE CONTRACTING WITH AN INDEPENDENT TESTING LABORATORY. REQUIREMENTS PER SECTION 106.2 OF COUNTY SPECIFICATIONS. THE CONTRACTOR IS TO PROVIDE THE CITY OF SAN LUIS WITH ALL CERTIFIED COPIES OF FIELD DENSITY, CONCRETE COMPRESSION BREAKS AND LABORATORY TESTS.
13. ANY SURVEY MONUMENT DISTURBED DURING CONSTRUCTION ACTIVITIES SHALL BE REPLACED IN ACCORDANCE WITH CITY OF SAN LUIS STANDARD DETAILS BY THE CONTRACTOR AT NO EXTRA COST TO THE OWNER. CONTRACTOR SHALL UTILIZE A REGISTERED LAND SURVEYOR TO ASSURE PROPER PLACEMENT OF SAID MONUMENT.
14. AZPDES PERMIT SHALL BE OBTAINED PRIOR TO THE START OF GRADING ACTIVITIES.
15. GRADING SPOILS TO BE SPREAD ON ADJACENT LOTS.
16. STOCKPILED EXISTING ABC FOUND IN THIS PROJECT MAY ONLY BE REUSED ON THIS PROJECT IF IT IS TESTED AND MEETS REQUIRED PROJECT SPECIFICATIONS.

UTILITY COMPANIES

| | |
|-------------------------------------------------------------------------------------------------------------------------------------|----------------------------------------------------------------------------------------------------------------------------------------------------|
| WATER - CITY OF SAN LUIS 1090 E. UNION STREET P.O. BOX 3750 SAN LUIS, AZ 85349 (928) 341-8577 (ANTONIO SANDOVAL) | FIRE PROTECTION - SAN LUIS FIRE DEPARTMENT 1165 N. MCCAIN AVENUE P.O. BOX 445 SAN LUIS, AZ 85349 (928) 341-8550 (ANGEL RAMIREZ) |
| SEWER - CITY OF SAN LUIS 1090 E. UNION STREET P.O. BOX 3750 SAN LUIS, AZ 85349 (928) 341-8577 (GILBERTO TORRES) | CABLE TELEVISION - TIME WARNER 1289 SOUTH 2ND AVENUE YUMA, ARIZONA 85364 (760) 250-2489 (PLACIDO LOPEZ) |
| ELECTRIC - APS COMPANY MAIL STATION 4853 6700 E. 30TH STREET YUMA, ARIZONA 85364 (928) 336-9838 (ANNE CAMACHO) | TELEPHONE - CENTURYLINK 1850 EAST 20TH STREET YUMA, ARIZONA 85365 (928) 343-8943 (ED ALUPAY) |

VICINITY MAP

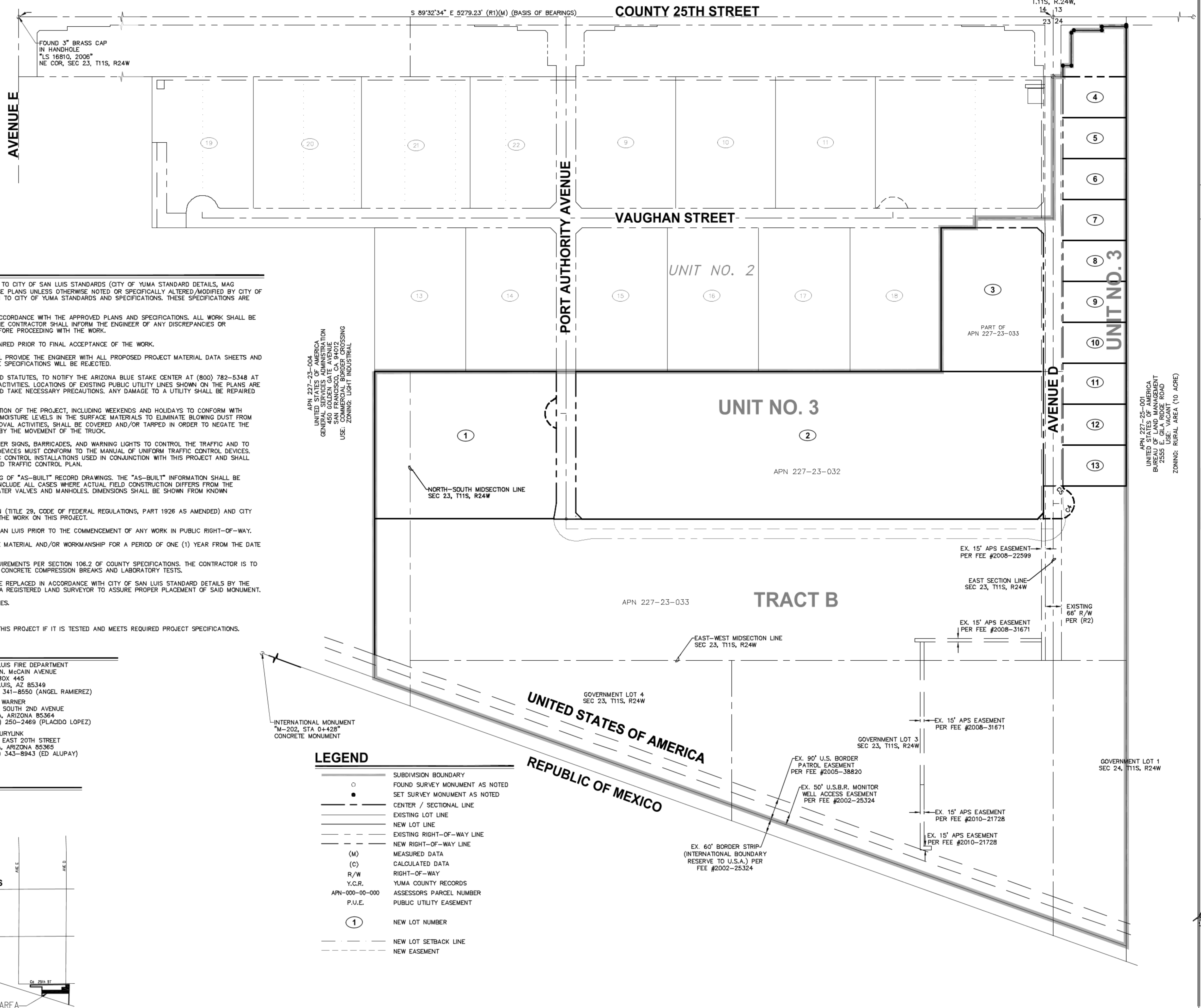
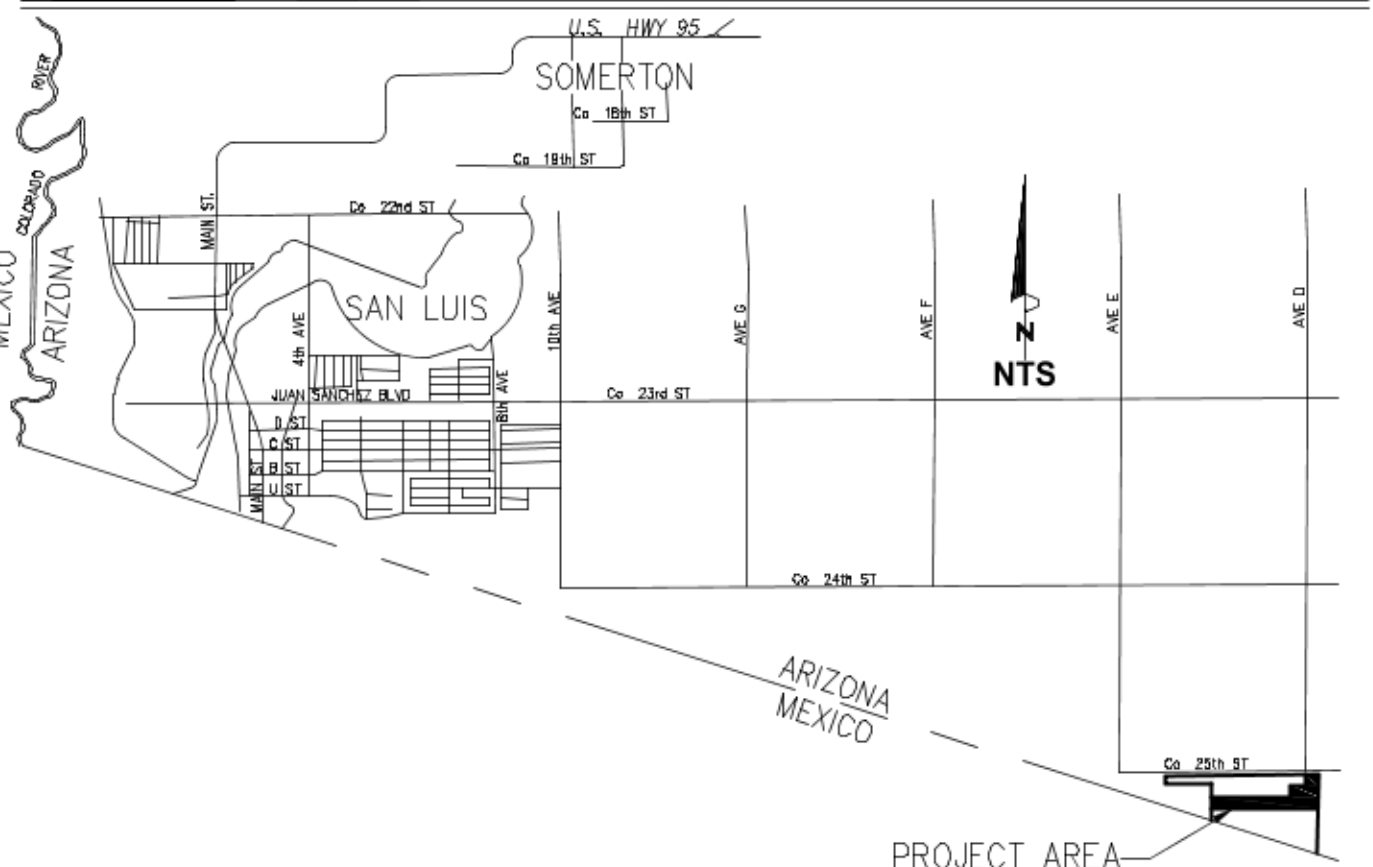

LEGEND

| | |
|----------------|--------------------------------|
| ○ | SUBDIVISION BOUNDARY |
| ● | FOUND SURVEY MONUMENT AS NOTED |
| ○ | SET SURVEY MONUMENT AS NOTED |
| — | CENTER / SECTIONAL LINE |
| --- | EXISTING LOT LINE |
| --- | NEW LOT LINE |
| --- | EXISTING RIGHT-OF-WAY LINE |
| --- | NEW RIGHT-OF-WAY LINE |
| (M) | MEASURED DATA |
| (C) | CALCULATED DATA |
| R/W | RIGHT-OF-WAY |
| Y.C.R. | YUMA COUNTY RECORDS |
| APN-000-00-000 | ASSESSORS PARCEL NUMBER |
| P.U.E. | PUBLIC UTILITY EASEMENT |
| ① | NEW LOT NUMBER |
| --- | NEW LOT SETBACK LINE |
| --- | NEW EASEMENT |

APN 227-23-033
 UNITED STATES OF AMERICA
 GENERAL SERVICES ADMINISTRATION
 450 GOLDEN GATE AVENUE
 SAN FRANCISCO, CALIFORNIA 94142
 USE: COMMERCIAL BORDER CROSSING
 ZONING: LIGHT INDUSTRIAL

APN 227-25-001
 UNITED STATES OF AMERICA
 BUREAU OF LAND MANAGEMENT
 2525 E. GILA ROAD
 YUMA, ARIZONA 85304
 ZONING: RURAL AREA (10 ACRE)

MAGRINO INDUSTRIAL PARK
UNIT NO. 3
 CITY OF SAN LUIS
 YUMA COUNTY, ARIZONA
 COVER SHEET

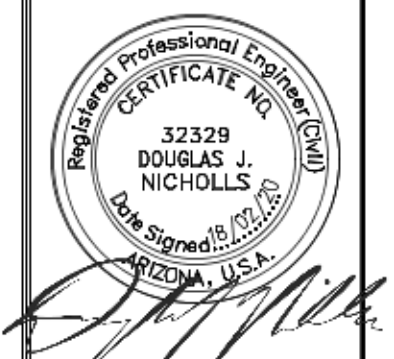

Date: DEC. 2019
 Designed: K.L.B.
 Drawn: J.M.G.
 Checked: D.J.N.
 Proj. No.: 19-096

CORE ENGINEERING GROUP, PLLC
 200 East 16th Street, Suite 150
 Yuma, AZ 85364
 V - 928-344-5931 F - 928-344-5932
 www.CoreEngineeringGroup.com
 Core@core-e-g.com

DRAWING RECORD:

| No. | DATE: |
|-----|-------|
| | |
| | |
| | |
| | |
| | |
| | |
| | |
| | |
| | |

THIS DRAWING AND THE DATA CONTAINED HEREON ARE THE PROPERTY OF CORE ENGINEERING GROUP, PLLC AND SHALL NOT BE USED, REPRODUCED OR TRANSMITTED WITHOUT THE PRIOR EXPRESS CONSENT OF THE COMPANY. NGR SHALL HAVE ANY DATA OR INFORMATION CONTAINED HEREON BE USED IN A MANNER INCONSISTENT WITH THE PRIOR EXPRESS WRITTEN AUTHORIZATION OF THE COMPANY.

Tue, 18 Feb 2020 - 3:34pm - Z:\2019\19-096\Drawings\Prelim\Plat\19-096 Prelim Plat-Crafting Plan.dwg - Core Engineering Group, PLLC

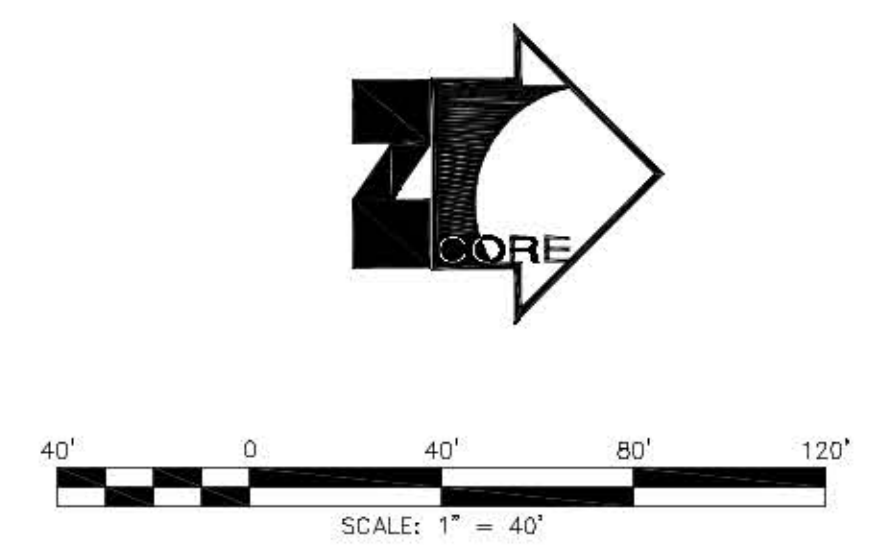
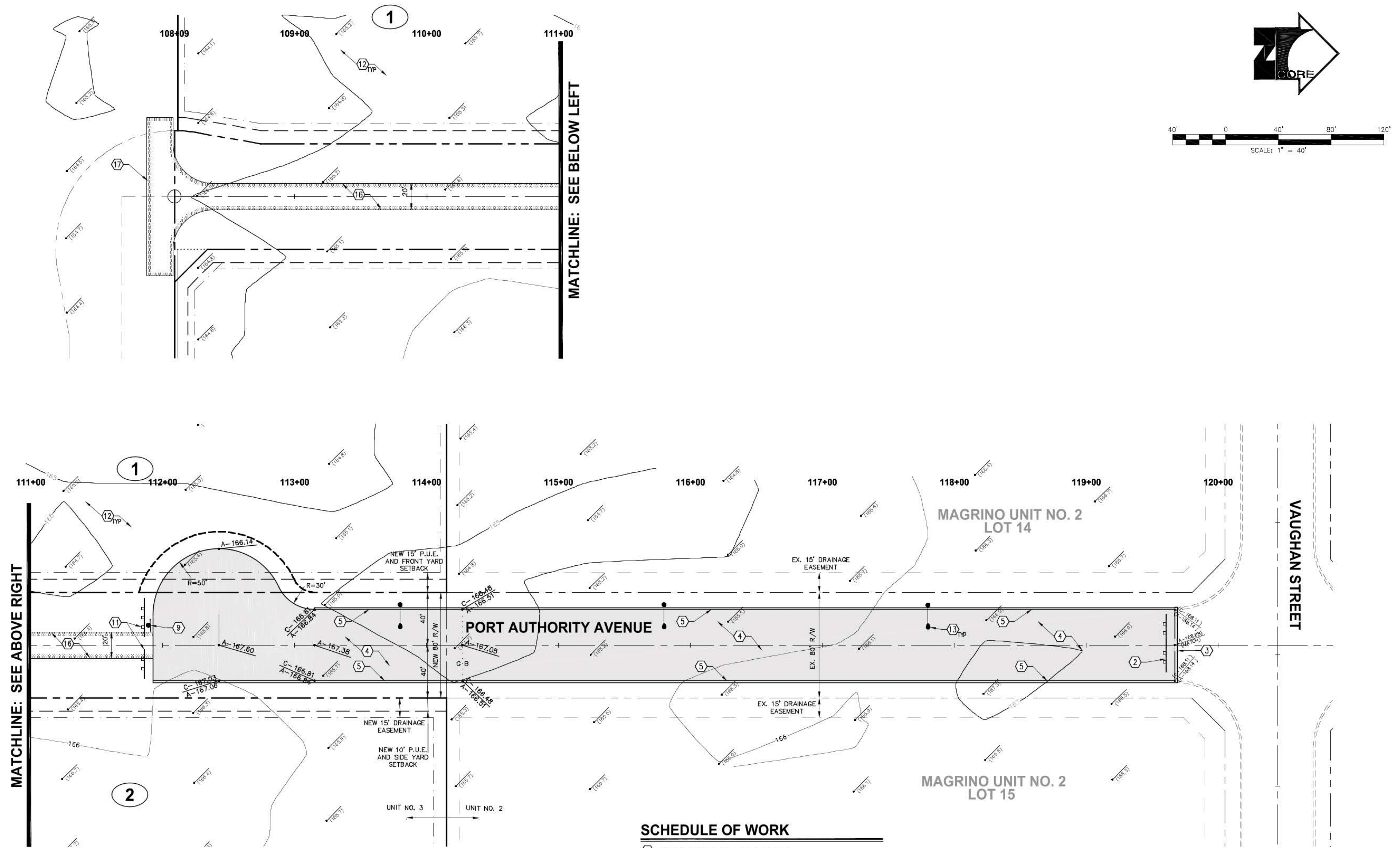

SCHEDULE OF WORK

| | |
|----------------------------------------------------------------|-----------------------|
| (2) REMOVE EXISTING SIGN AND BARRICADE | |
| (3) SAWCUT AND MATCH EXISTING | |
| (4) INDUSTRIAL STREET SECTION | -SEE DETAIL A/6 |
| (5) PAVEMENT BORDER CURB | -SEE DETAIL C/6 |
| (7) STREET NAME SIGN WITH 30"X30" R1-1 "STOP" SIGN. | -SEE DETAIL D/6 |
| (8) 30" X 30" R1-1 "STOP" SIGN | -SEE DETAIL D/6 |
| (9) 30" X 30" R5-1 "DO NOT ENTER" SIGN | -SEE DETAIL D/6 (SIM) |
| (10) 24" SOLID WHITE THERMOPLASTIC STRIPE | |
| (11) TYPE III BARRICADE | -SEE DETAILS A/7 |
| (12) ON-SITE LOT GRADING AND RETENTION BY FUTURE LOT DEVELOPER | -SEE DETAIL B/7 |
| (13) STREET LIGHT | -BY APS |
| (14) REMOVE EXISTING PAVEMENT | |
| (16) 20' WIDE ABC ACCESS ROAD | -SEE DETAIL E&F/6 |
| (17) HAMMERHEAD TURN AROUND | -COY STD NO. 3-210 |

UTILITY DISCLAIMER

THE UNDERGROUND UTILITIES SHOWN HAVE BEEN LOCATED FROM THE FIELD SURVEY INFORMATION AND EXISTING DRAWINGS. THE SURVEYOR MAKES NO GUARANTEE THAT THE UNDERGROUND UTILITIES SHOWN COMPRISE ALL SUCH UTILITIES IN THE AREA, EITHER IN SERVICE OR ABANDONED. THE SURVEYOR FURTHER DOES NOT WARRANT THAT THE UNDERGROUND UTILITIES SHOWN ARE IN THE EXACT LOCATION INDICATED ALTHOUGH HE DOES CERTIFY THAT THEY ARE LOCATED AS ACCURATELY AS POSSIBLE FROM INFORMATION AVAILABLE. THE SURVEYOR HAS NOT PHYSICALLY LOCATED THE UNDERGROUND UTILITIES.

DRAWING RECORD:

| | |
|-----|------|
| No. | DATE |
| | |

CORE ENGINEERING GROUP, PLLC
 200 East 16th Street, Suite 150
 Yuma, AZ 85364
 V - 928-344-5931 F - 928-344-5932
 www.CoreEngineeringGroup.com
 Core@core-e-g.com

CORE
MAGRINO INDUSTRIAL PARK UNIT NO. 3
CITY OF SAN LUIS
YUMA COUNTY, ARIZONA
ROADWAY PLAN

Call at least two full working days before you begin excavation.

ARIZONA 811
Arizona Blue Stake, Inc.

Dial 8-1-1 or 1-800-STAKE-IT (782-5348)
In Maricopa County: (602) 263-1100

Professional Engineer
 CERTIFICATE NO. 32329
 DOUGLAS J. NICHOLLS
 License No. 18770
 ARIZONA, U.S.A.

Date: DEC. 2019
 Designed: K.L.B.
 Drawn: J.M.G.
 Checked: D.J.N.
 Proj. No.: 19-096

THIS DRAWING AND THE DATA CONTAINED HEREON ARE THE PROPERTY OF CORE ENGINEERING GROUP, PLLC AND SHALL NOT BE USED, REPRODUCED OR TRANSMITTED, WITHOUT THE PRIOR EXPRESS CONSENT OF THE COMPANY, NOR SHALL ANY DATA OR INFORMATION CONTAINED HEREON BE USED IN A MANNER INCONSISTENT WITH THE PRIOR EXPRESS WRITTEN AUTHORIZATION OF THE COMPANY.

2

SHEET

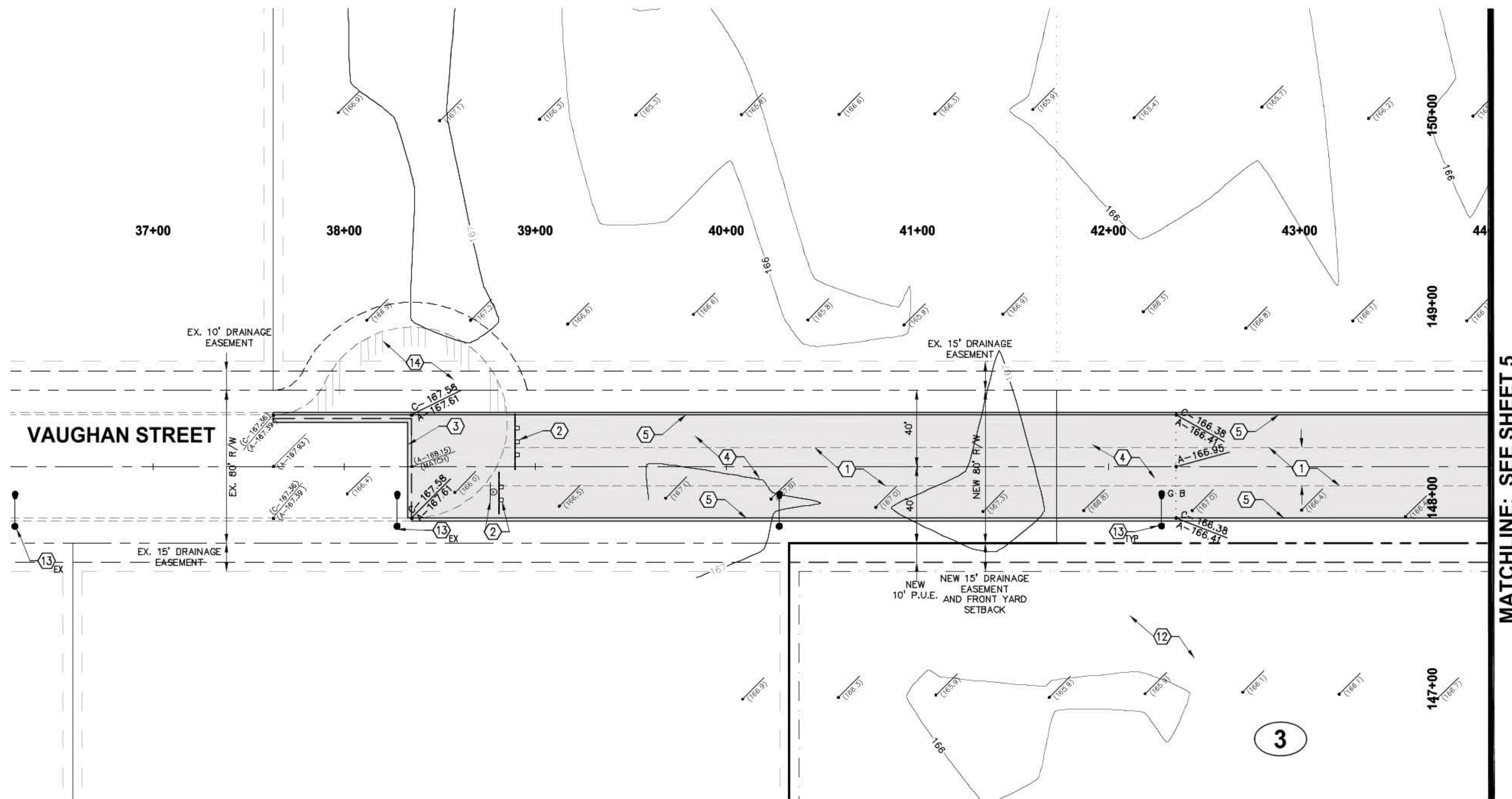

MATCHLINE: SEE SHEET 5

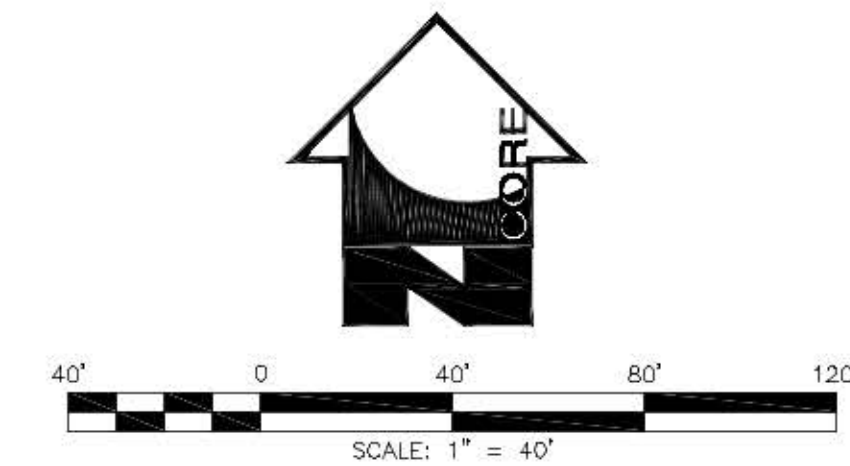

LEGEND

- FOUND SURVEY MONUMENT AS NOTED
- CENTER / SECTIONAL LINE
- - - EXISTING EASEMENT (AS NOTED)
- - - EXISTING LOT LINE
- - - EXISTING RIGHT-OF-WAY LINE
- - - EXISTING SUBDIVISION BOUNDARY
- - - EXISTING GROUND LINE
- - - EX 12\"/>
- - - EX 8\"/>
- - - EX-E-(EH)
- - - EX T-(OH)
- - - EX-E-(HG)
- - - EX T-(UG)
- - - EX-G
- - - NEW BORDER CURB
- - - EXISTING ASPHALT
- - - EXISTING CONCRETE
- - - EXISTING ABC CANAL ROAD
- - - NEW ASPHALT
- - - NEW ABC PAVEMENT FOR ACCESS ROAD
- - - EXISTING CHAIN LINK FENCE
- - - EXISTING BARBED WIRE FENCE
- - - EXISTING POWER POLE
- - - EXISTING GUY WIRE ANCHOR
- - - EXISTING WATER METER
- - - EXISTING BLOW OFF
- - - EXISTING SEWER MANHOLE
- - - EXISTING ELECTRICAL TRANSFORMER
- - - EXISTING TELEPHONE PEDESTAL
- - - EXISTING ELECTRICAL JUNCTION BOX
- - - EXISTING SIGN
- - - NEW SIGN
- - - NEW STREET NAME AND STOP SIGN
- - - NEW LIGHT POLE
- - - NEW BARRICADE
- - - EXISTING BARRICADE
- - - EXISTING FIRE HYDRANT
- - - EXISTING VALVE
- - - EXISTING GAS METER
- - - EXISTING SLOPE
- - - NEW SLOPE
- - - RIGHT-OF-WAY
- - - FINISHED FLOOR ELEVATION
- - - EXISTING GROUND ELEVATION
- - - EXISTING CURB ELEVATION
- - - EXISTING GUTTER ELEVATION
- - - EXISTING CONCRETE ELEVATION
- - - EXISTING SIDEWALK ELEVATION
- - - EXISTING ASPHALT ELEVATION
- - - EXISTING GRATE ELEVATION
- - - EXISTING INVERT ELEVATION
- - - NEW CURB ELEVATION
- - - NEW GUTTER ELEVATION
- - - NEW ASPHALT ELEVATION
- - - NEW FLDW WAY ELEVATION
- - - NEW GRADE BREAK
- - - NEW LOT NUMBER
- (M) MEASURED DATA
- (R1) RECORDED DATA PER BOOK 23 OF PLATS
PAGES 57&58, Y.C.R.
- (R2) RECORDED DATA PER COUNTY ROAD MAP
#3856
- (C) CALCULATED DATA

SCHEDULE OF WORK

- 1 REMOVE EXISTING ABC AND STOCKPILE FOR REUSE (GEN. NOTE 16, SHT 1)
- 2 REMOVE EXISTING SIGN AND BARRICADE
- 3 SAWCUT AND MATCH EXISTING
- 4 INDUSTRIAL STREET SECTION -SEE DETAIL A/6
- 5 PAVEMENT BORDER CURB -SEE DETAIL C/6
- 7 STREET NAME SIGN WITH 30"x30" R1-1 "STOP" SIGN. -SEE DETAIL D/6
- 8 30" X 30" R1-1 "STOP" SIGN -SEE DETAIL D/6
- 9 30" X 30" R5-1 "DO NOT ENTER" SIGN -SEE DETAIL D/6 (SIM)
- 10 24" SOLID WHITE THERMOPLASTIC STRIPE
- 11 TYPE III BARRICADE -SEE DETAILS A/7
- 12 ON-SITE LOT GRADING AND RETENTION BY FUTURE LOT DEVELOPER -SEE DETAIL B/7
- 13 STREET LIGHT -BY APS
- 14 REMOVE EXISTING PAVEMENT
- 15 PROVIDE COLD JOINT FOR FUTURE REMOVAL

UTILITY DISCLAIMER

THE UNDERGROUND UTILITIES SHOWN HAVE BEEN LOCATED FROM THE FIELD SURVEY INFORMATION AND EXISTING DRAWINGS. THE SURVEYOR MAKES NO GUARANTEE THAT THE UNDERGROUND UTILITIES SHOWN COMPRISE ALL SUCH UTILITIES IN THE AREA, EITHER IN SERVICE OR ABANDONED. THE SURVEYOR FURTHER DOES NOT WARRANT THAT THE UNDERGROUND UTILITIES SHOWN ARE IN THE EXACT LOCATION INDICATED ALTHOUGH HE DOES CERTIFY THAT THEY ARE LOCATED AS ACCURATELY AS POSSIBLE FROM INFORMATION AVAILABLE. THE SURVEYOR HAS NOT PHYSICALLY LOCATED THE UNDERGROUND UTILITIES.



DRAWING RECORD:

DATE:

No.:

CORE ENGINEERING GROUP, PLLC
 200 East 16th Street, Suite 150
 Yuma, AZ 85364
 V - 928-344-5931 F - 928-344-5932
 www.CoreEngineeringGroup.com
 Core@core-e-g.com

CORE

MAGRINO INDUSTRIAL PARK
 UNIT NO. 3
 CITY OF SAN LUIS
 YUMA COUNTY, ARIZONA
 ROADWAY PLAN

Date: DEC. 2019
 Designed: K.L.B.
 Drawn: J.M.G.
 Checked: D.J.N.
 Proj. No.: 19-096

THIS DRAWING AND THE DATA CONTAINED HEREON ARE THE PROPERTY OF CORE ENGINEERING GROUP, PLLC AND SHALL NOT BE USED, REPRODUCED OR TRANSMITTED WITHOUT THE PRIOR EXPRESS CONSENT OF THE COMPANY. NOR SHALL ANY DATA OR INFORMATION CONTAINED HEREON BE USED IN A MANNER INCONSISTENT WITH THE PRIOR EXPRESS WRITTEN AUTHORIZATION OF THE COMPANY.

3

SHEET

Tue, 18 Feb 2020 3:55pm Z:\2019\19-096\Drawings\Prelim\Plat\19-096 Prelim Plat\19-096 Prelim Plat.dwg. * Core Engineering Group, PLLC

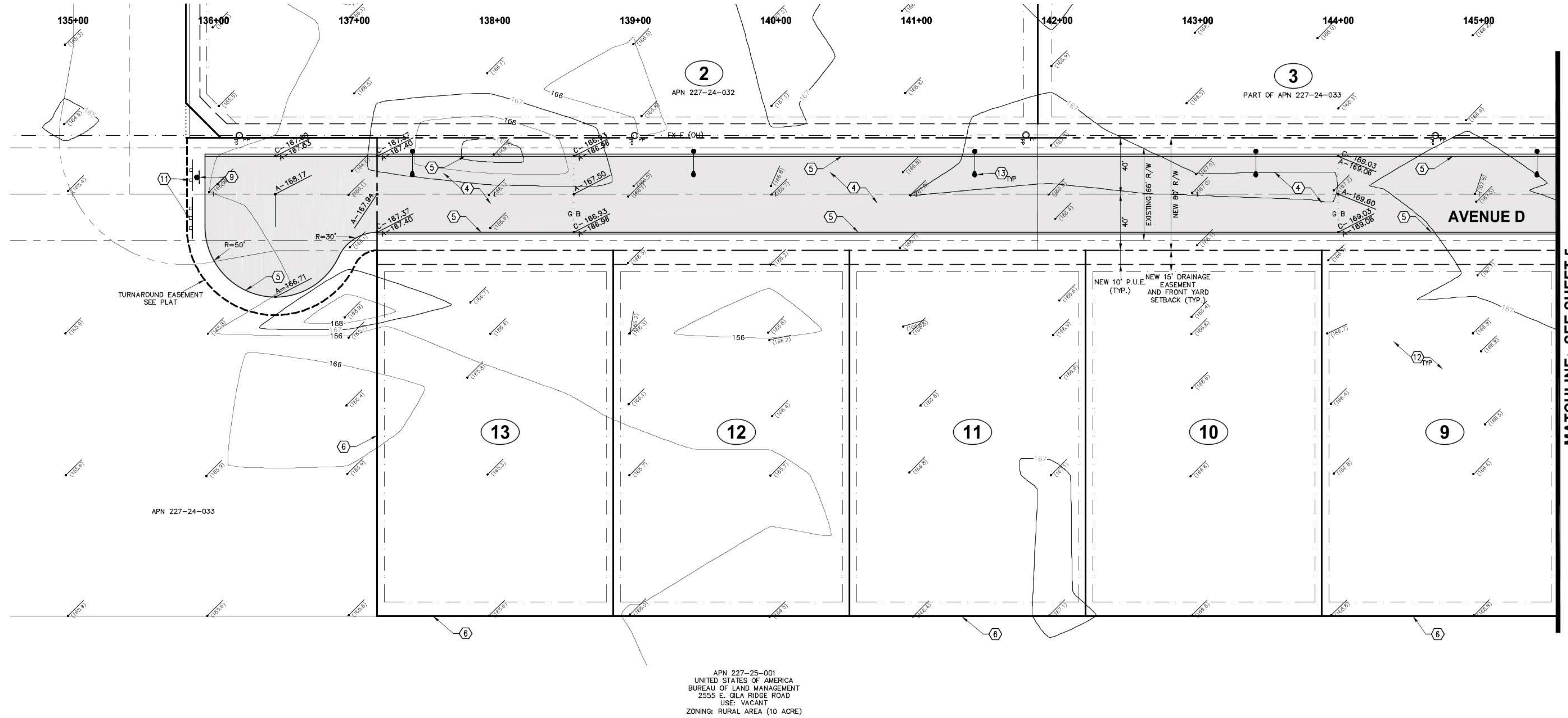

SCHEDULE OF WORK

- ① REMOVE EXISTING ABC AND STOCKPILE FOR REUSE (GEN. NOTE 16, SHEET 1)
- ② REMOVE EXISTING SIGN AND BARRICADE
- ③ SAWCUT AND MATCH EXISTING
- ④ INDUSTRIAL STREET SECTION -SEE DETAIL A/6
- ⑤ PAVEMENT BORDER CURB -SEE DETAIL C/6
- ⑥ 6' SCREEN WALL BY FUTURE LOT DEVELOPERS OR GYPA
- ⑦ STREET NAME SIGN WITH 30"x30" R1-1 "STOP" SIGN. -SEE DETAIL D/6
- ⑧ 30" X 30" R1-1 "STOP" SIGN -SEE DETAIL D/6
- ⑨ 30" X 30" R5-1 "DO NOT ENTER" SIGN -SEE DETAIL D/6 (SIM)
- ⑩ 24" SOLID WHITE THERMOPLASTIC STRIPE
- ⑪ TYPE III BARRICADE -SEE DETAILS A/7
- ⑫ ON-SITE LOT GRADING AND RETENTION BY FUTURE LOT DEVELOPER -SEE DETAIL B/7
- ⑬ STREET LIGHT -BY APS
- ⑭ REMOVE EXISTING PAVEMENT

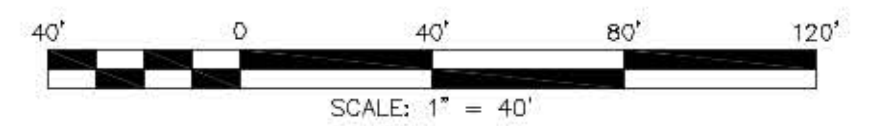

Call at least two full working days before you begin excavation.

ARIZONA 811
Arizona Blue Stake, Inc.

Dial 8-1-1 or 1-800-STAKE-IT (782-5348)
In Maricopa County: (602) 263-1100

UTILITY DISCLAIMER

THE UNDERGROUND UTILITIES SHOWN HAVE BEEN LOCATED FROM THE FIELD SURVEY INFORMATION AND EXISTING DRAWINGS. THE SURVEYOR MAKES NO GUARANTEE THAT THE UNDERGROUND UTILITIES SHOWN COMPRISE ALL SUCH UTILITIES IN THE AREA, EITHER IN SERVICE OR ABANDONED. THE SURVEYOR FURTHER DOES NOT WARRANT THAT THE UNDERGROUND UTILITIES SHOWN ARE IN THE EXACT LOCATION INDICATED ALTHOUGH HE DOES CERTIFY THAT THEY ARE LOCATED AS ACCURATELY AS POSSIBLE FROM INFORMATION AVAILABLE. THE SURVEYOR HAS NOT PHYSICALLY LOCATED THE UNDERGROUND UTILITIES.

| | |
|-----------------|--|
| DRAWING RECORD: | |
| No. | |
| DATE: | |

CORE ENGINEERING GROUP, PLLC
200 East 16th Street, Suite 150
Yuma, AZ 85364
V - 928-344-5931 F - 928-344-5932
www.CoreEngineeringGroup.com
Core@core-e-g.com

**MAGRINO INDUSTRIAL PARK
UNIT NO. 3
CITY OF SAN LUIS
YUMA COUNTY, ARIZONA
ROADWAY PLAN**

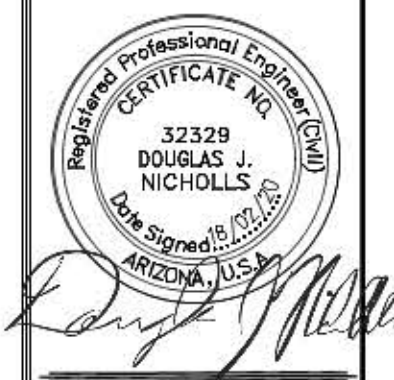

Date: DEC. 2019
Designed: K.L.B.
Drawn: J.M.G.
Checked: D.J.N.
Proj. No.: 19-096

THIS DRAWING AND THE DATA CONTAINED HEREON ARE THE PROPERTY OF CORE ENGINEERING GROUP, PLLC AND SHALL NOT BE USED, REPRODUCED OR TRANSMITTED WITHOUT THE PRIOR EXPRESS CONSENT OF THE COMPANY. NGR SHALL HAVE ANY DATA OR INFORMATION CONTAINED HEREON BE USED IN A MANNER INCONSISTENT WITH THE PRIOR EXPRESS WRITTEN AUTHORIZATION OF THE COMPANY.

Tue, 18 Feb 2020 3:35pm - 3:35pm, Z:\2019\19-096\Drawings\Final\Plat\19-096 Prelim Plat\19-096 Prelim Plat.dwg, * Core Engineering Group, PLLC

WORK PERMITTED WITH UNIT NO. 2 BUT NOT CONSTRUCTED - SEE PREVIOUS DESIGN

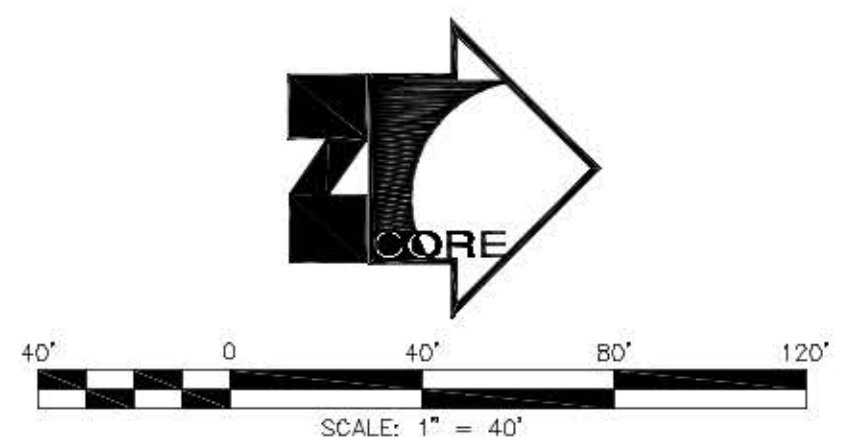

MATCHLINE: SEE SHEET 3

MATCHLINE: SEE SHEET 4

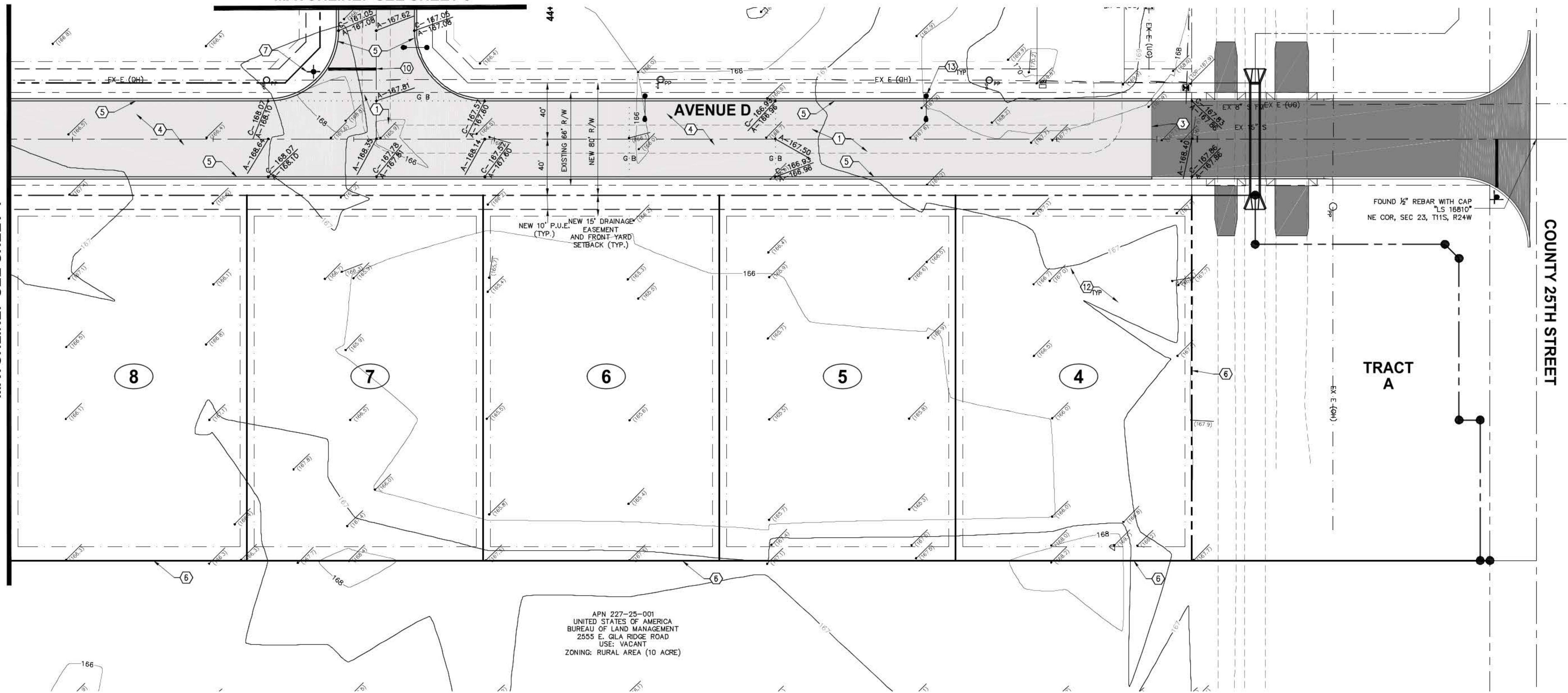

APN 227-25-001
UNITED STATES OF AMERICA
BUREAU OF LAND MANAGEMENT
2555 E. GILA RIDGE ROAD
USE: VACANT
ZONING: RURAL AREA (10 ACRE)

SCHEDULE OF WORK

- 1 REMOVE EXISTING ABC AND STOCKPILE FOR REUSE (GEN NOTE 16, PAGE 1)
- 2 REMOVE EXISTING SIGN AND BARRICADE
- 3 SAWCUT AND MATCH EXISTING
- 4 INDUSTRIAL STREET SECTION -SEE DETAIL A/6
- 5 PAVEMENT BORDER CURB -SEE DETAIL C/6
- 6 6' SCREEN WALL BY FUTURE LOT DEVELOPERS OR GYPA
- 7 STREET NAME SIGN WITH 30"x30" R1-1 "STOP" SIGN. -SEE DETAIL D/6
- 8 30" X 30" R1-1 "STOP" SIGN -SEE DETAIL D/6
- 9 30" X 30" R5-1 "DO NOT ENTER" SIGN -SEE DETAIL D/6 (SIM)
- 10 24" SOLID WHITE THERMOPLASTIC STRIPE
- 11 TYPE III BARRICADE -SEE DETAILS A/7
- 12 ON-SITE LOT GRADING AND RETENTION BY FUTURE LOT DEVELOPER -SEE DETAIL B/7
- 13 STREET LIGHT -BY APS
- 14 REMOVE EXISTING PAVEMENT

UTILITY DISCLAIMER

THE UNDERGROUND UTILITIES SHOWN HAVE BEEN LOCATED FROM THE FIELD SURVEY INFORMATION AND EXISTING DRAWINGS. THE SURVEYOR MAKES NO GUARANTEE THAT THE UNDERGROUND UTILITIES SHOWN COMPRISE ALL SUCH UTILITIES IN THE AREA, EITHER IN SERVICE OR ABANDONED. THE SURVEYOR FURTHER DOES NOT WARRANT THAT THE UNDERGROUND UTILITIES SHOWN ARE IN THE EXACT LOCATION INDICATED ALTHOUGH HE DOES CERTIFY THAT THEY ARE LOCATED AS ACCURATELY AS POSSIBLE FROM INFORMATION AVAILABLE. THE SURVEYOR HAS NOT PHYSICALLY LOCATED THE UNDERGROUND UTILITIES.



Date: DEC. 2019
Designed: K.L.B.
Drawn: J.M.G.
Checked: D.J.N.
Proj. No.: 19-096

**MAGRINO INDUSTRIAL PARK
UNIT NO. 3
CITY OF SAN LUIS
YUMA COUNTY, ARIZONA
ROADWAY PLAN**

CORE ENGINEERING GROUP, PLLC
200 East 16th Street, Suite 150
Yuma, AZ 85364
V - 928-344-5931 F - 928-344-5932
www.CoreEngineeringGroup.com
Core@core-e-g.com

No. _____
DATE: _____

DRAWING RECORD:

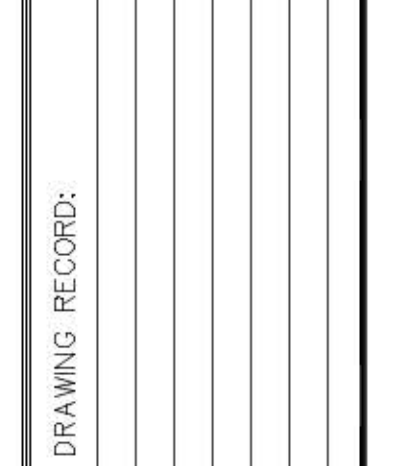

THIS DRAWING AND THE DATA CONTAINED HEREON ARE THE PROPERTY OF CORE ENGINEERING GROUP, PLLC AND SHALL NOT BE USED, REPRODUCED OR TRANSMITTED, WITHOUT THE PRIOR EXPRESS CONSENT OF THE COMPANY, NOR SHALL ANY DATA OR INFORMATION CONTAINED HEREON BE USED IN A MANNER INCONSISTENT WITH THE PRIOR EXPRESS WRITTEN AUTHORIZATION OF THE COMPANY.

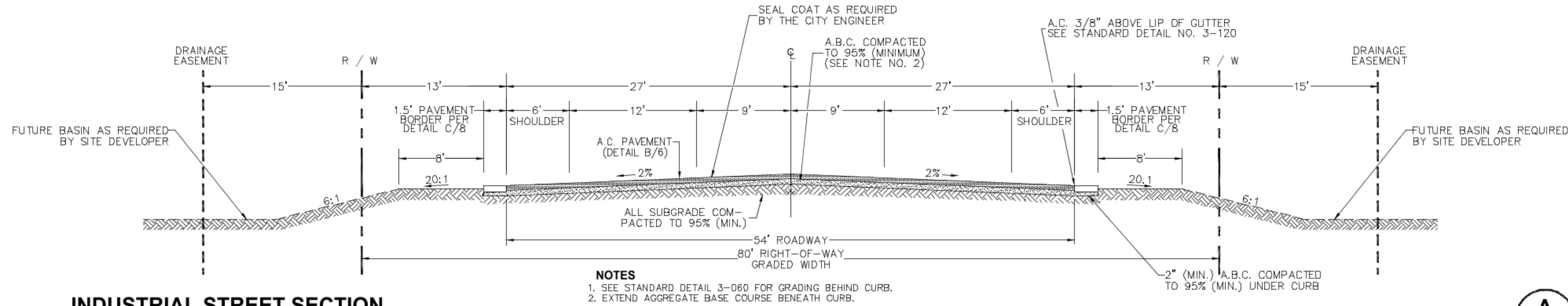

INDUSTRIAL STREET SECTION

YUMA COUNTY CONSTRUCTION STANDARD DETAIL DRAWINGS STD. NO. 2-079 (MODIFIED, NTS)

NOTES
 1. SEE STANDARD DETAIL 3-060 FOR GRADING BEHIND CURB.
 2. EXTEND AGGREGATE BASE COURSE BENEATH CURB.

A
6

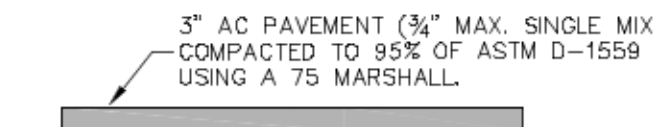

10" ABC MOISTURE CONDITIONED TO +/- 2% AND COMPACT TO 100% PER ASTM D-698

NOTES
 1. ASPHALT SHALL MEET CURRENT YUMA COUNTY STANDARD SPEC. 321 FOR 3/4 INCH MAXIMUM SINGLE COARSE.
 2. AGGREGATE BASE SHALL YUMA COUNTY SPECIFICATION SECTION 310.

PAVEMENT STRUCTURAL SECTION

B
6

8" ABC MOISTURE CONDITIONED TO +/- 2% AND COMPACT TO 100% PER ASTM D-698

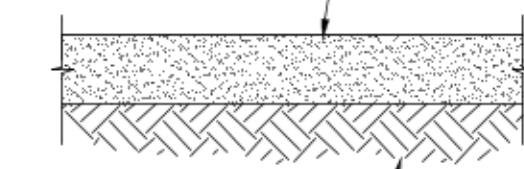

12" NATIVE SOIL SCARIFIED AND MOISTURE CONDITIONED TO +/- 2% OF OPTIMUM. COMPACT TO 95% PER ASTM D-698.

NOTES
 1. ASPHALT SHALL MEET CURRENT YUMA COUNTY STANDARD SPEC. 321 FOR 3/4 INCH MAXIMUM SINGLE COARSE.
 2. AGGREGATE BASE SHALL YUMA COUNTY SPECIFICATION SECTION 310.

ABC STRUCTURAL SECTION

E
6

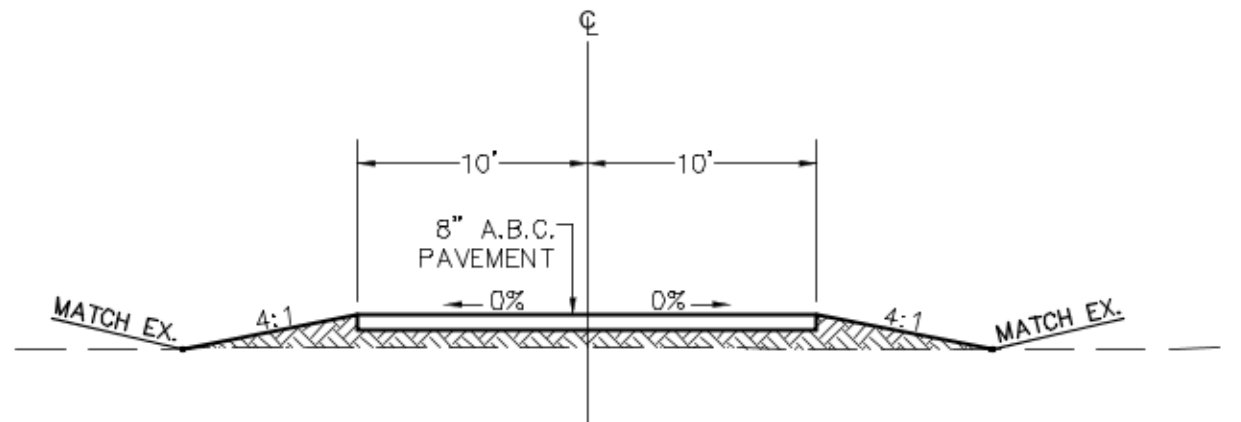

NOTE
 1. AGGREGATE BASE SHALL MEET YUMA COUNTY SPECIFICATION SECTION 310.

20' ABC ACCESS ROADWAY

F
6

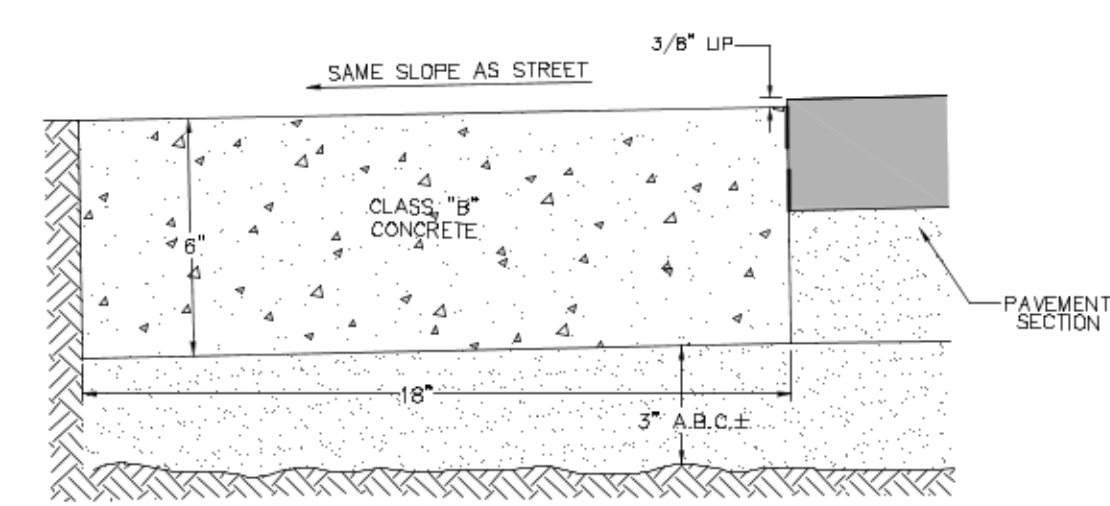

NOTES
 1. IN GROUP A SOIL CONDITIONS: 8" OF CONCRETE MAY BE SUBSTITUTED FOR 6" OF CONCRETE AND 3" A.B.C. WITH THE APPROVAL OF THE CITY ENGINEER.
 2. BROOM FINISH EXPOSED SURFACE.
 3. CONTRACTION JOINT SPACING AS PER SECTION 3.3.8 OF PUBLIC WORKS STANDARD.
 4. EXPANSION JOINT SPACING 50' MAX AS PER SECTION 3.3.8 OF PUBLIC WORKS STANDARDS.

PAVEMENT BORDER

YUMA COUNTY CONSTRUCTION STANDARD DETAIL NO. 3-160 (MODIFIED)

C
6

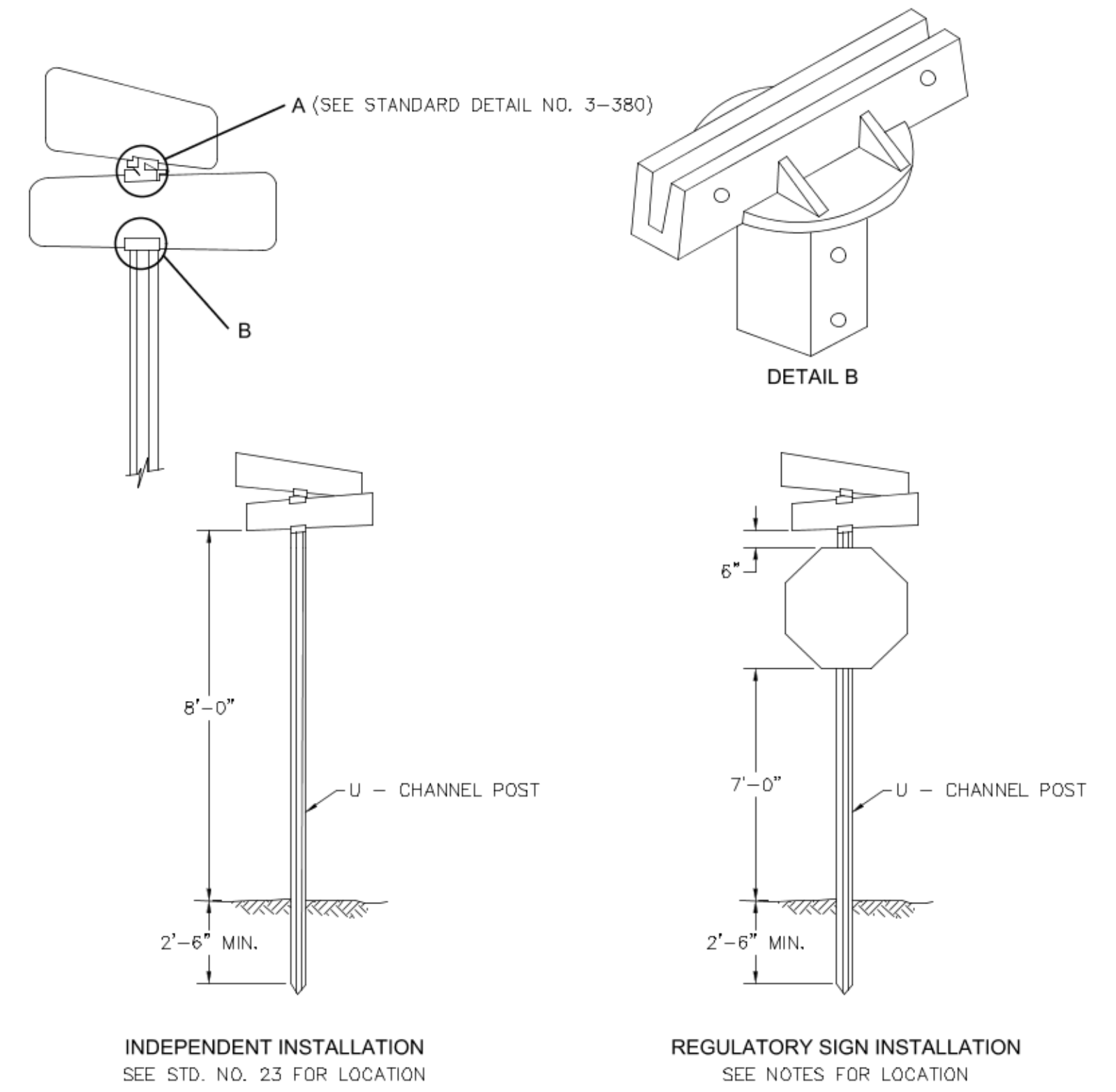

NOTES
 U-CHANNEL POSTS SHALL BE FLANGED GALVANIZED AND A MINIMUM OF 2 LB. PER FOOT IN WEIGHT.
 WHEN STREET NAME SIGNS ARE MOUNTED WITH A REGULATORY SIGN, THE LOCATION WILL BE AS PER THE M.U.T.C.D.
 SEE GENERAL NOTES ON STD. DETAIL NO. 3-380.

DOUBLE FACED STREET SIGN - STOP SIGN

YUMA COUNTY CONSTRUCTION STANDARD DETAIL NO. 3-380

D
6

Tue, 18 Feb 2020 - 3:33pm, Z:\2019\19-096\Draws\Final\19-096 Details.dwg, Core Engineering Group, PLLC

CORE ENGINEERING GROUP, PLLC
 200 East 16th Street, Suite 150
 Yuma, AZ 85364
 V - 928-344-5931 F - 928-344-5932
 www.CoreEngineeringGroup.com
 Core@core-e-g.com

MAGRINO INDUSTRIAL PARK
UNIT NO. 3
CITY OF SAN LUIS
YUMA COUNTY, ARIZONA
PAVING DETAILS

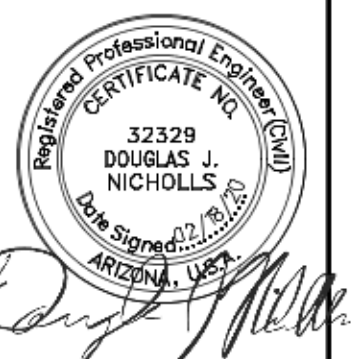

Date: DEC. 2019
 Designed: K.L.B.
 Drawn: J.M.G.
 Checked: D.J.N.
 Proj. No.: 19-096



UTILITY DISCLAIMER

THE UNDERGROUND UTILITIES SHOWN HAVE BEEN LOCATED FROM THE FIELD SURVEY INFORMATION AND EXISTING DRAWINGS. THE SURVEYOR MAKES NO GUARANTEE THAT THE UNDERGROUND UTILITIES SHOWN COMPRISE ALL SUCH UTILITIES IN THE AREA, EITHER IN SERVICE OR ABANDONED. THE SURVEYOR FURTHER DOES NOT WARRANT THAT THE UNDERGROUND UTILITIES SHOWN ARE IN THE EXACT LOCATION INDICATED ALTHOUGH HE DOES CERTIFY THAT THEY ARE LOCATED AS ACCURATELY AS POSSIBLE FROM INFORMATION AVAILABLE. THE SURVEYOR HAS NOT PHYSICALLY LOCATED THE UNDERGROUND UTILITIES.

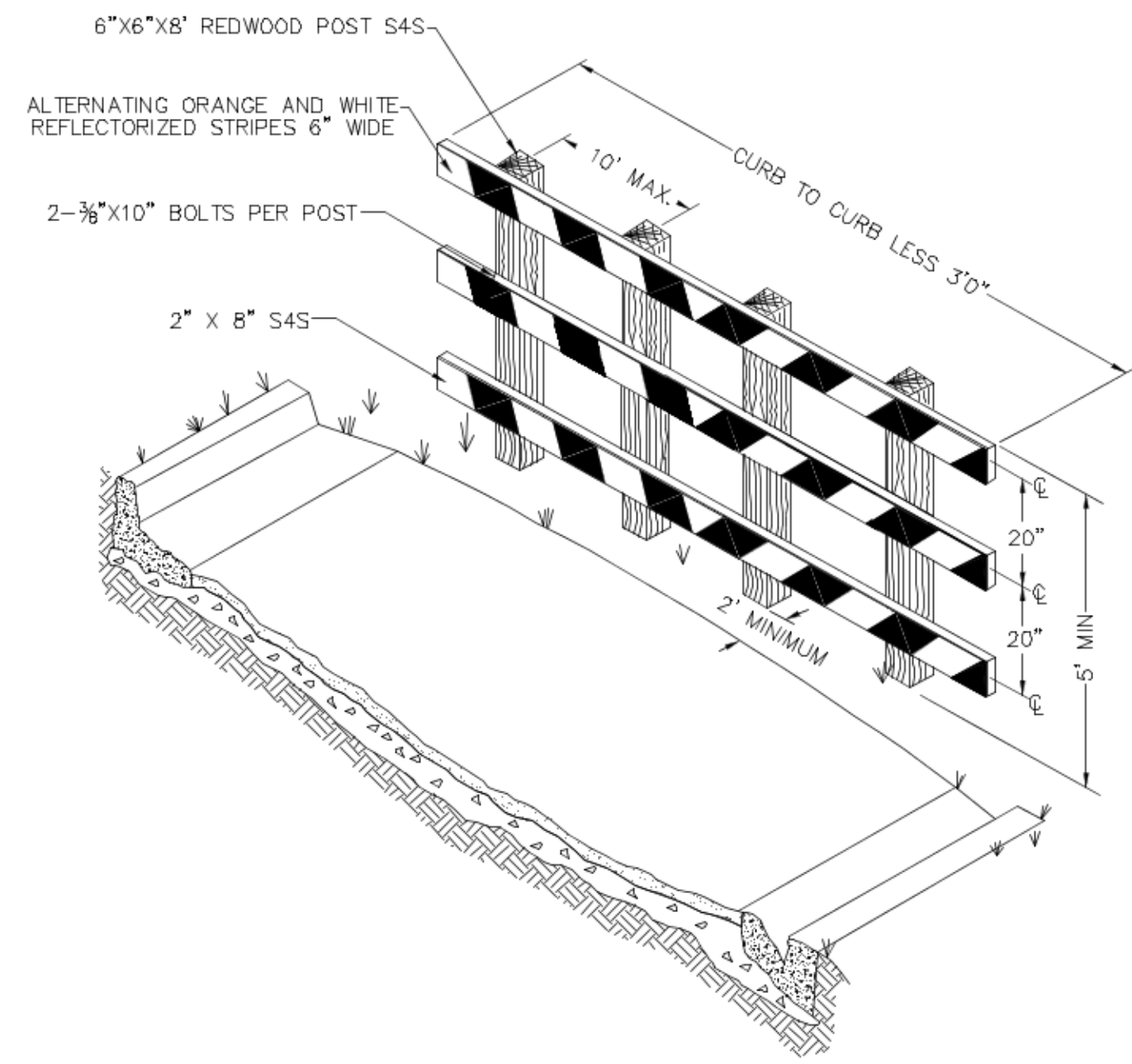

NOTES
 BARRICADE MARKINGS SHALL BE 3M ENGINEER GRADE REFLECTIVE SHEETING ON .080" THICK ALUMINUM SHEET OR EQUAL AS DIRECTED BY PUBLIC WORKS.
 RAIL TIMBER TO BE NO. 1 D.F. S4S AND TO RECEIVE 2 COATS OF OUTSIDE WHITE PAINT ON NON-REFLECTIVE SURFACES. STRIPES SHALL SLOPE TOWARD THE CENTER OF THE PAVEMENT FROM BOTH SIDES, UNLESS OTHERWISE INSTRUCTED BY THE ENGINEER.

| STREET WIDTH | NO. OF POSTS |
|--------------|--------------|
| 26' - 32' | 4 |
| 38' - 44' | 5 |
| 48' | 6 |
| 68' - 72' | 8 |

TYPE III BARRICADE

YUMA COUNTY CONSTRUCTION STANDARD DETAIL NO. 3-360

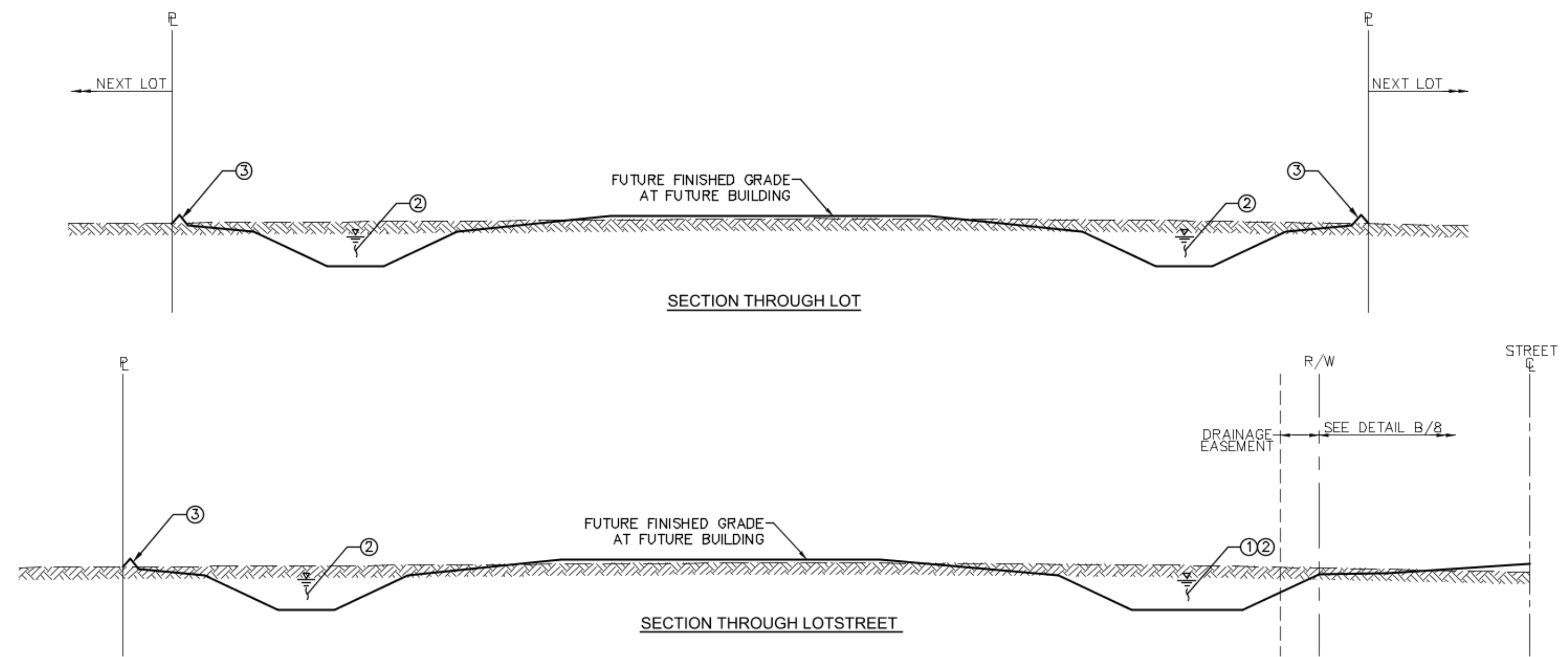
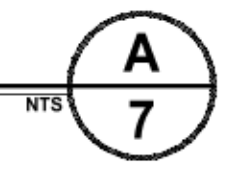

- ① ROADWAY RETENTION BASIN - SEE DETAILS B&C/B
- ② POSSIBLE ON SITE RETENTION BY LOT DEVELOPER
- ③ BERM AS REQUIRED TO PREVENT CROSS PROPERTY DRAINAGE - BY LOT DEVELOPER

NOTE
 THE INTENT OF THIS DETAIL IS TO SHOW THE LOT DRAINAGE/GRADING FUTURE CONCEPT. THIS DETAIL IS FOR REFERENCE ONLY SINCE THE LOT GRADING AND ROADSIDE DRAINAGE WILL BE BY INDIVIDUAL LOT DEVELOPER AT THE TIME OF LOT DEVELOPMENT. A STANDARD GRADING PERMIT IS STILL REQUIRED FOR THE LOT DEVELOPMENT.

CONCEPTUAL ON-SITE RETENTION AND LOT GRADING DETAIL (BY OTHERS)

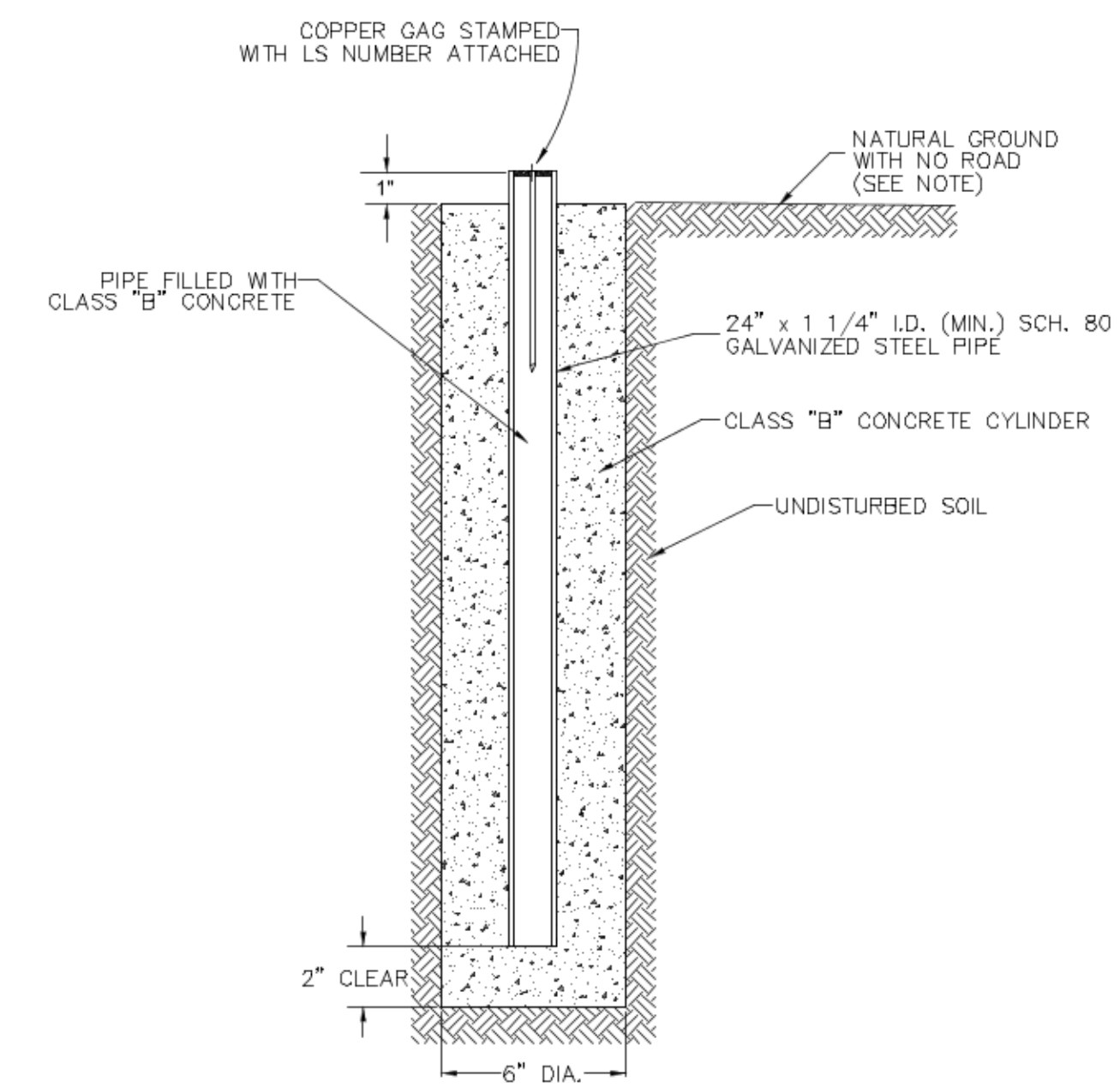
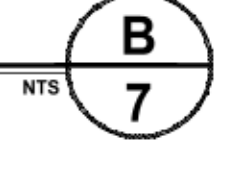

NOTE
 IF SUBDIVISION BOUNDARY MONUMENT IS LOCATED WITHIN THE ROADWAY, INSTALL STANDARD NO. 4-080.

BOUNDARY MONUMENT

YUMA COUNTY CONSTRUCTION STANDARD DETAIL DRAWING NO. 4-030

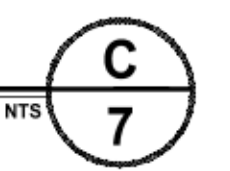

UTILITY DISCLAIMER

THE UNDERGROUND UTILITIES SHOWN HAVE BEEN LOCATED FROM THE FIELD SURVEY INFORMATION AND EXISTING DRAWINGS. THE SURVEYOR MAKES NO GUARANTEE THAT THE UNDERGROUND UTILITIES SHOWN COMPRISE ALL SUCH UTILITIES IN THE AREA, EITHER IN SERVICE OR ABANDONED. THE SURVEYOR FURTHER DOES NOT WARRANT THAT THE UNDERGROUND UTILITIES SHOWN ARE IN THE EXACT LOCATION INDICATED ALTHOUGH HE DOES CERTIFY THAT THEY ARE LOCATED AS ACCURATELY AS POSSIBLE FROM INFORMATION AVAILABLE. THE SURVEYOR HAS NOT PHYSICALLY LOCATED THE UNDERGROUND UTILITIES.



Date: DEC. 2019
 Designed: K.L.B.
 Drawn: J.M.G.
 Checked: D.J.N.
 Proj. No.: 19-096

Tue, 18 Feb 2020 - 3:32pm, Z:\2019\19-096\Draws\Final\19-096 Details.dwg, * Core Engineering Group, PLLC

CORE ENGINEERING GROUP, PLLC
 200 East 16th Street, Suite 150
 Yuma, AZ 85364
 V - 928-344-5931 F - 928-344-5932
 www.CoreEngineeringGroup.com
 core@core-e-g.com

**MAGRINO INDUSTRIAL PARK
 UNIT NO. 3
 CITY OF SAN LUIS
 YUMA COUNTY, ARIZONA**



DRAWING RECORD:
 No. _____
 DATE: _____

THIS DRAWING AND THE DATA CONTAINED HEREON ARE THE PROPERTY OF CORE ENGINEERING GROUP, PLLC AND SHALL NOT BE USED, REPRODUCED OR TRANSMITTED, WITHOUT THE PRIOR EXPRESS CONSENT OF THE COMPANY, NOR SHALL ANY DATA OR INFORMATION CONTAINED HEREON BE USED IN A MANNER INCONSISTENT WITH THE PRIOR EXPRESS WRITTEN AUTHORIZATION OF THE COMPANY.

Tue, 18 Feb 2020 - 3:37pm, Z:\2019\19-096\Draws\Finalm_Plan\19-096 Prelim Plot -Waterworks.dwg, Core Engineering Group, PLLC

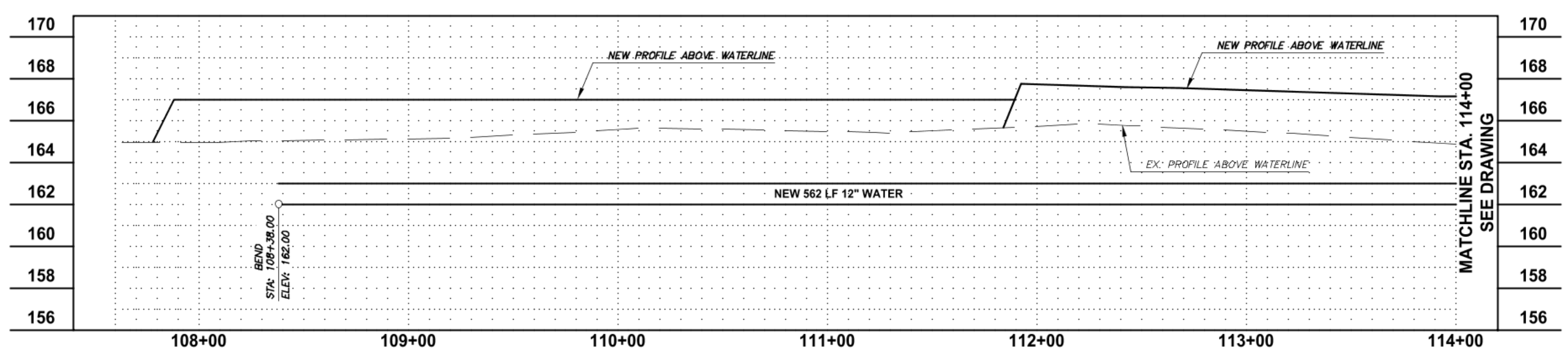
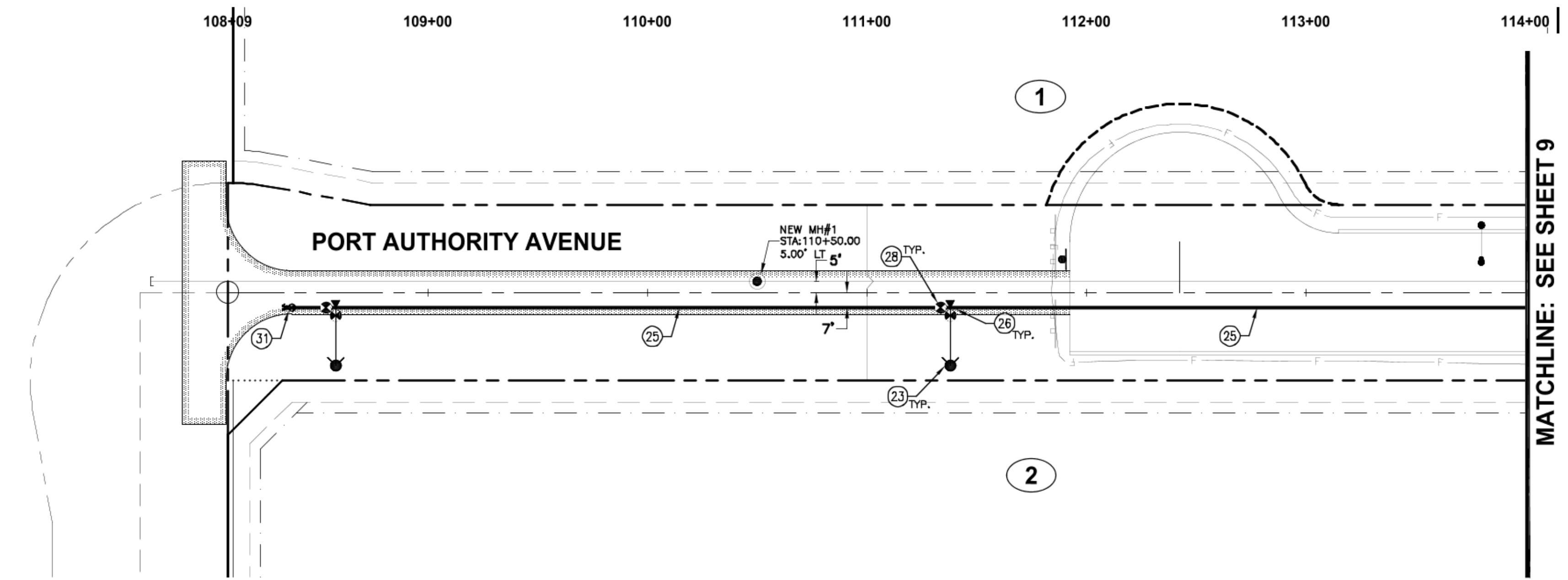
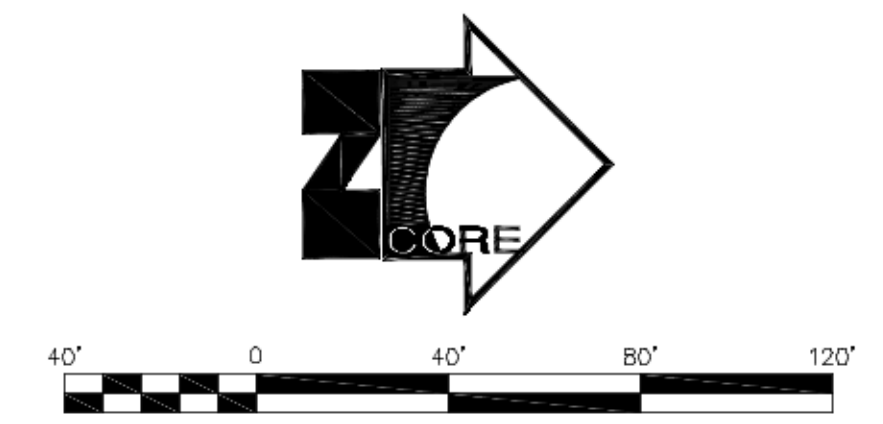

WATER SCHEDULE OF WORK

- 20 12" 45° BEND AND THRUST BLOCK (COST INCLUDED IN WATERLINE) -COY STD NO. 5-020
-COY STD NO. 5-025
- 21 1" SINGLE WATER SERVICE (COST INCLUDED IN ITEM 22) -COY STD NO. 5-035
-COY STD NO. 5-015
-SEE DETAIL A/8
- 22 1" SERVICE METER BOX -COY STD NO. 5-055
- 23 6" FIRE HYDRANT ASSEMBLY AND STREET MARKER -COY STD NO. 5-155
-COY STD NO. 5-160
- 24 6" CLASS 150 C900 PVC WATERLINE -COY STD NO. 5-010
- 25 12" CLASS 150 C900 PVC WATERLINE -COY STD NO. 5-010
- 26 12" X 12" X 6" TEE AND THRUST BLOCK (COST INCLUDED IN WATERLINE) -COY STD NO. 5-020
-COY STD NO. 5-025
- 27 6" GATE VALVE WITH ANCHOR, VALVE BOX, FRAME AND COVER -COY STD NO. 5-065
-COY STD NO. 5-075
- 28 12" GATE VALVE WITH ANCHOR, VALVE BOX, AND COVER -COY STD NO. 5-065
-COY STD NO. 5-075
- 29 CONNECT NEW 12" WATERLINE TO EXISTING
- 30 12" 90° BEND AND THRUST BLOCK (COST INCLUDED IN WATERLINE) -COY STD NO. 5-020
-COY STD NO. 5-025
- 31 WATERMAIN BLOWOFF -COY STD NO. 5-085

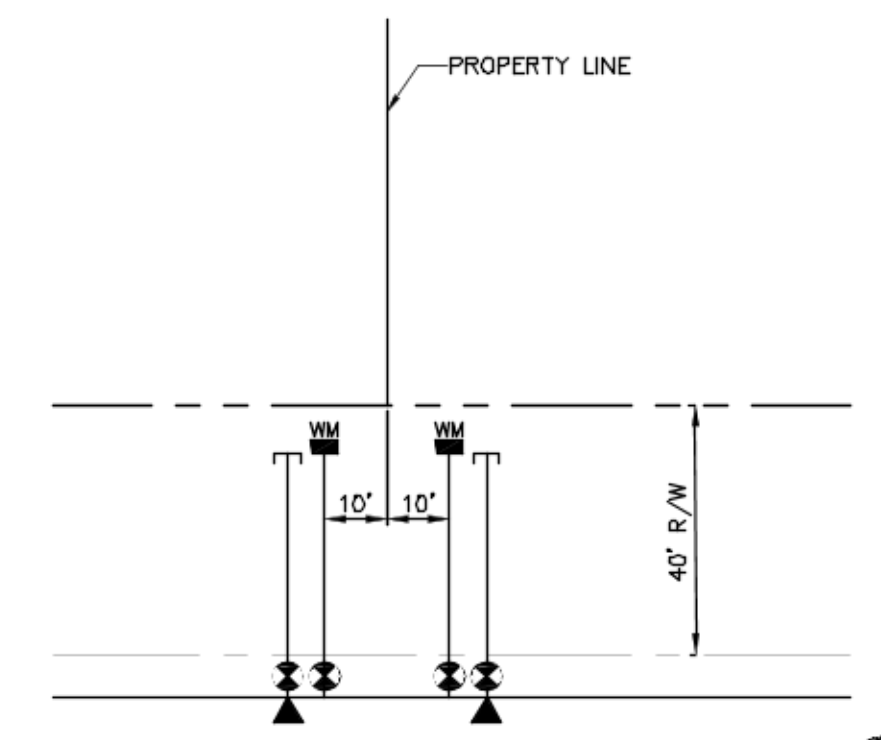

TYPICAL WATER SERVICE SPACING FROM PROPERTY LINE A
8

UTILITY DISCLAIMER

THE UNDERGROUND UTILITIES SHOWN HAVE BEEN LOCATED FROM THE FIELD SURVEY INFORMATION AND EXISTING DRAWINGS. THE SURVEYOR MAKES NO GUARANTEE THAT THE UNDERGROUND UTILITIES SHOWN COMPRISE ALL SUCH UTILITIES IN THE AREA, EITHER IN SERVICE OR ABANDONED. THE SURVEYOR FURTHER DOES NOT WARRANT THAT THE UNDERGROUND UTILITIES SHOWN ARE IN THE EXACT LOCATION INDICATED ALTHOUGH HE DOES CERTIFY THAT THEY ARE LOCATED AS ACCURATELY AS POSSIBLE FROM INFORMATION AVAILABLE. THE SURVEYOR HAS NOT PHYSICALLY LOCATED THE UNDERGROUND UTILITIES.

DRAWING RECORD:

No. _____

DATE: _____

CORE ENGINEERING GROUP, PLLC
 200 East 16th Street, Suite 150
 Yuma, AZ 85364
 V - 928-344-5931 F - 928-344-5932
 www.CoreEngineeringGroup.com
 Core@core-e-g.com

MAGRINO INDUSTRIAL PARK UNIT NO. 3
 CITY OF SAN LUIS
 YUMA COUNTY, ARIZONA

PORT AUTHORITY - WATER PLAN & PROFILE

Call at least two full working days before you begin excavation.

ARIZONA 811
 Arizona Blue Stake, Inc.
 Dial 8-1-1 or 1-800-STAKE-IT (782-5348)
 In Maricopa County: (602) 263-1100

Professional Engineer
 CERTIFICATE NO. 32329
 DOUGLAS J. NICHOLLS
 License No. 19-096
 ARIZONA, A.S.E.

Date: DEC. 2019

Designed: K.L.B.

Drawn: J.M.G.

Checked: D.J.N.

Proj. No.: 19-096

8

SHEET

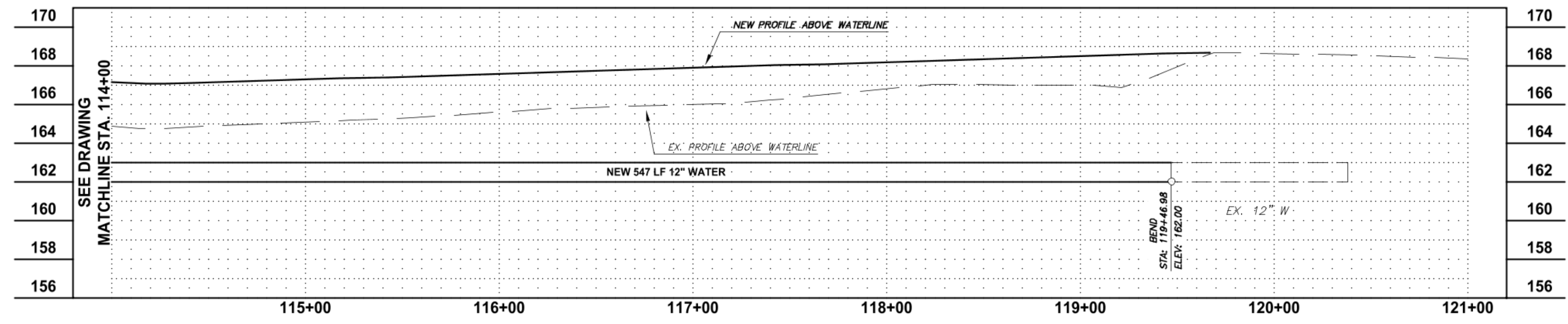
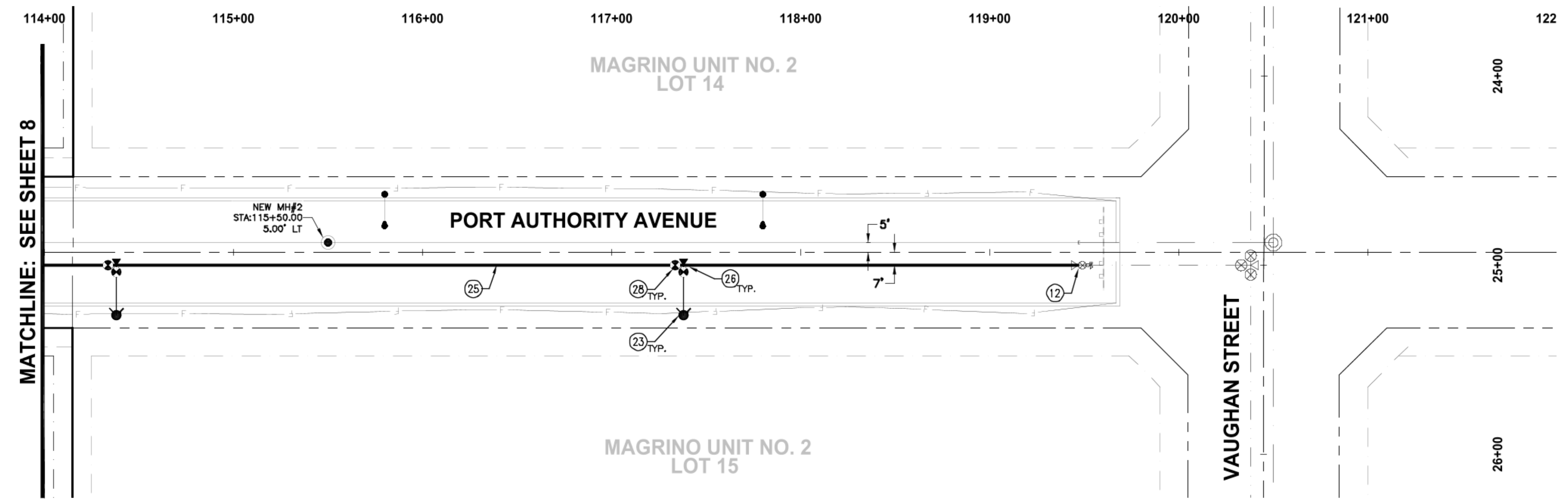
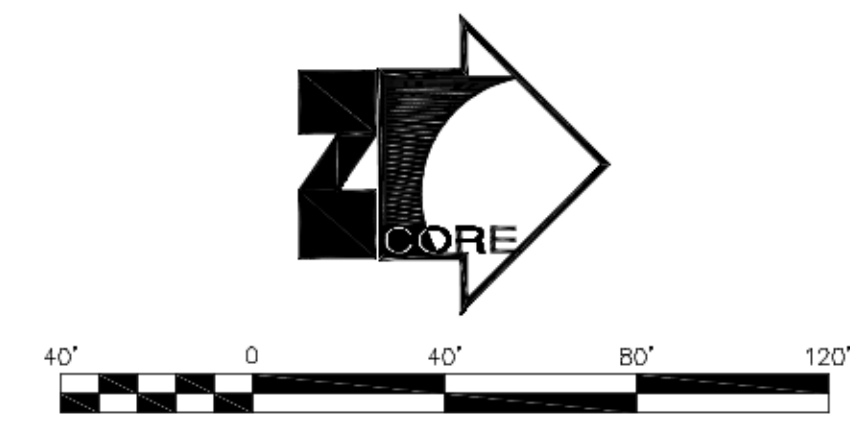

WATER SCHEDULE OF WORK

- 20 12" 45° BEND AND THRUST BLOCK (COST INCLUDED IN WATERLINE) -COY STD NO. 5-020
-COY STD NO. 5-025
- 21 1" SINGLE WATER SERVICE (COST INCLUDED IN ITEM 22) -COY STD NO. 5-035
-COY STD NO. 5-015
-SEE DETAIL A/B
- 22 1" SERVICE METER BOX -COY STD NO. 5-055
- 23 6" FIRE HYDRANT ASSEMBLY AND STREET MARKER -COY STD NO. 5-155
-COY STD NO. 5-160
- 24 6" CLASS 150 C900 PVC WATERLINE -COY STD NO. 5-010
- 25 12" CLASS 150 C900 PVC WATERLINE -COY STD NO. 5-010
- 26 12" X 12" X 6" TEE AND THRUST BLOCK (COST INCLUDED IN WATERLINE) -COY STD NO. 5-020
-COY STD NO. 5-025
- 27 6" GATE VALVE WITH ANCHOR, VALVE BOX, FRAME AND COVER -COY STD NO. 5-065
-COY STD NO. 5-075
- 28 12" GATE VALVE WITH ANCHOR, VALVE BOX, AND COVER -COY STD NO. 5-065
-COY STD NO. 5-075
- 29 CONNECT NEW 12" WATERLINE TO EXISTING
- 30 12" 90° BEND AND THRUST BLOCK (COST INCLUDED IN WATERLINE) -COY STD NO. 5-020
-COY STD NO. 5-025
- 31 WATERMAIN BLOWOFF -COY STD NO. 5-085

UTILITY DISCLAIMER

THE UNDERGROUND UTILITIES SHOWN HAVE BEEN LOCATED FROM THE FIELD SURVEY INFORMATION AND EXISTING DRAWINGS. THE SURVEYOR MAKES NO GUARANTEE THAT THE UNDERGROUND UTILITIES SHOWN COMPRISE ALL SUCH UTILITIES IN THE AREA, EITHER IN SERVICE OR ABANDONED. THE SURVEYOR FURTHER DOES NOT WARRANT THAT THE UNDERGROUND UTILITIES SHOWN ARE IN THE EXACT LOCATION INDICATED ALTHOUGH HE DOES CERTIFY THAT THEY ARE LOCATED AS ACCURATELY AS POSSIBLE FROM INFORMATION AVAILABLE. THE SURVEYOR HAS NOT PHYSICALLY LOCATED THE UNDERGROUND UTILITIES.



DRAWING RECORD:
 No. _____ DATE: _____
CORE ENGINEERING GROUP, PLLC
 200 East 16th Street, Suite 150
 Yuma, AZ 85364
 V - 928-344-5931 F - 928-344-5932
 www.CoreEngineeringGroup.com
 Core@core-e-g.com
CORE
MAGRINO INDUSTRIAL PARK UNIT NO. 3
CITY OF SAN LUIS YUMA COUNTY, ARIZONA
PORT AUTHORITY - WATER PLAN & PROFILE
 THIS DRAWING AND THE DATA CONTAINED HEREON ARE THE PROPERTY OF CORE ENGINEERING GROUP, PLLC AND SHALL NOT BE USED, REPRODUCED OR TRANSFERRED WITHOUT THE PRIOR EXPRESS CONSENT OF THE COMPANY, NOR SHALL ANY DATA OR INFORMATION CONTAINED HEREON BE USED IN A MANNER INCONSISTENT WITH THE PRIOR EXPRESS WRITTEN AUTHORIZATION OF THE COMPANY.
 Date: DEC. 2019
 Designed: K.L.B.
 Drawn: J.M.G.
 Checked: D.J.N.
 Proj. No.: 19-096
9
 SHEET

Tue, 18 Feb 2020 3:37pm, Z:\2019\19-096\Draws\Final\Plat\19-096 Prelim Plat\19-096.dwg, Core Engineering Group, PLLC

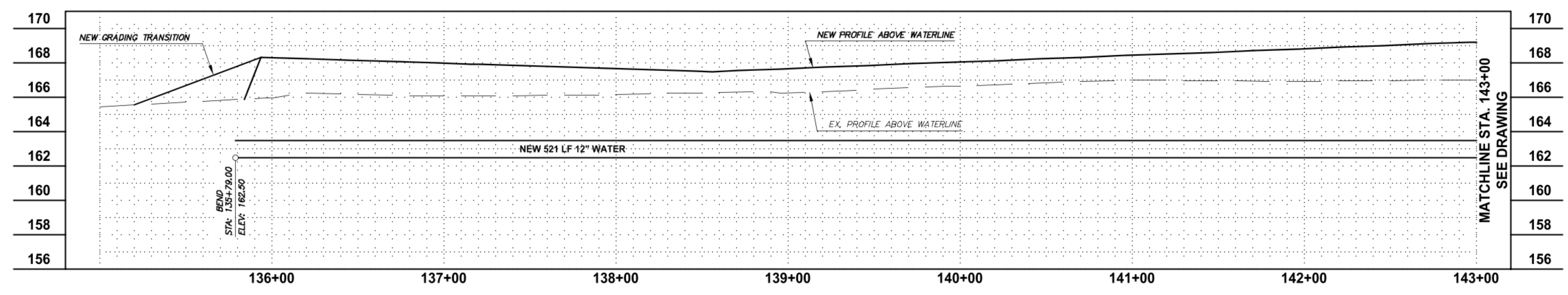
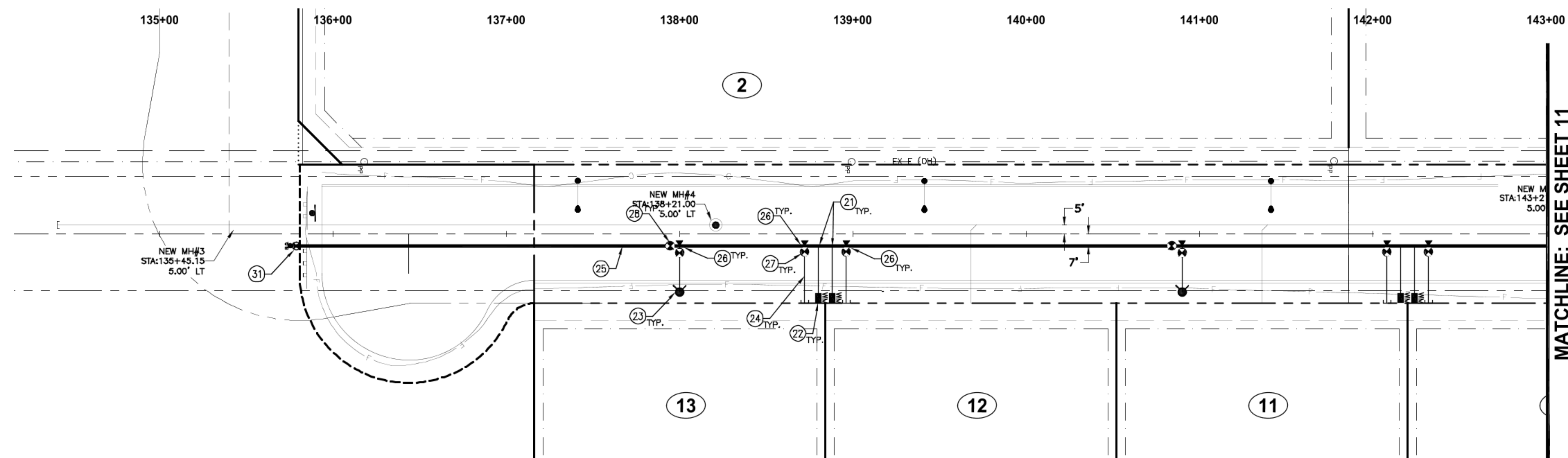
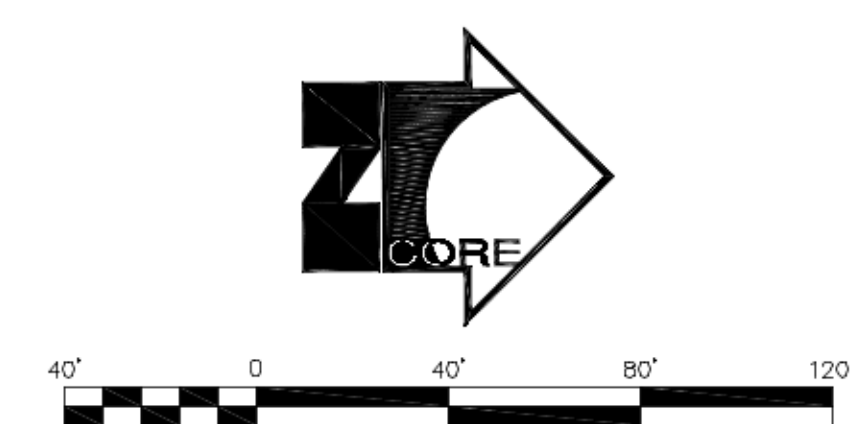

WATER SCHEDULE OF WORK

- 20 12" 45° BEND AND THRUST BLOCK (COST INCLUDED IN WATERLINE) -COY STD NO. 5-020
-COY STD NO. 5-025
- 21 1" SINGLE WATER SERVICE (COST INCLUDED IN ITEM 22) -COY STD NO. 5-035
-COY STD NO. 5-015
-SEE DETAIL A/B
- 22 1" SERVICE METER BOX -COY STD NO. 5-055
- 23 6" FIRE HYDRANT ASSEMBLY AND STREET MARKER -COY STD NO. 5-155
-COY STD NO. 5-160
- 24 6" CLASS 150 C900 PVC WATERLINE -COY STD NO. 5-010
- 25 12" CLASS 150 C900 PVC WATERLINE -COY STD NO. 5-010
- 26 12" X 12" X 6" TEE AND THRUST BLOCK (COST INCLUDED IN WATERLINE) -COY STD NO. 5-020
-COY STD NO. 5-025
- 27 6" GATE VALVE WITH ANCHOR, VALVE BOX, FRAME AND COVER -COY STD NO. 5-065
-COY STD NO. 5-075
- 28 12" GATE VALVE WITH ANCHOR, VALVE BOX, AND COVER -COY STD NO. 5-065
-COY STD NO. 5-075
- 29 CONNECT NEW 12" WATERLINE TO EXISTING
- 30 12" 90° BEND AND THRUST BLOCK (COST INCLUDED IN WATERLINE) -COY STD NO. 5-020
-COY STD NO. 5-025
- 31 WATERMAIN BLOWOFF -COY STD NO. 5-085

| | |
|-----------------|--|
| DRAWING RECORD: | |
| No. | |
| DATE: | |

CORE ENGINEERING GROUP, PLLC
 200 East 16th Street, Suite 150
 Yuma, AZ 85364
 V - 928.344.5931 F - 928.344.5932
 www.CoreEngineeringGroup.com
 Core@core-e-g.com

**MAGRINO INDUSTRIAL PARK
 UNIT NO. 3**
 CITY OF SAN LUIS
 YUMA COUNTY, ARIZONA
 AVE D - WATER PLAN & PROFILE

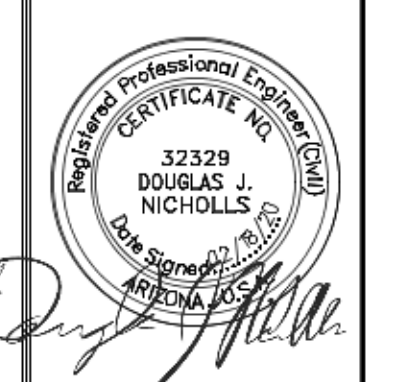

Date: DEC. 2019
 Designed: K.L.B.
 Drawn: J.M.G.
 Checked: D.J.N.
 Proj. No.: 19-096

UTILITY DISCLAIMER

THE UNDERGROUND UTILITIES SHOWN HAVE BEEN LOCATED FROM THE FIELD SURVEY INFORMATION AND EXISTING DRAWINGS. THE SURVEYOR MAKES NO GUARANTEE THAT THE UNDERGROUND UTILITIES SHOWN COMPRISE ALL SUCH UTILITIES IN THE AREA, EITHER IN SERVICE OR ABANDONED. THE SURVEYOR FURTHER DOES NOT WARRANT THAT THE UNDERGROUND UTILITIES SHOWN ARE IN THE EXACT LOCATION INDICATED ALTHOUGH HE DOES CERTIFY THAT THEY ARE LOCATED AS ACCURATELY AS POSSIBLE FROM INFORMATION AVAILABLE. THE SURVEYOR HAS NOT PHYSICALLY LOCATED THE UNDERGROUND UTILITIES.



Tue, 18 Feb 2020 3:38pm, Z:\2019\19-096\Draws\Prelim\Plat\19-096 Prelim Plat\19-096.dwg, Core Engineering Group, PLLC

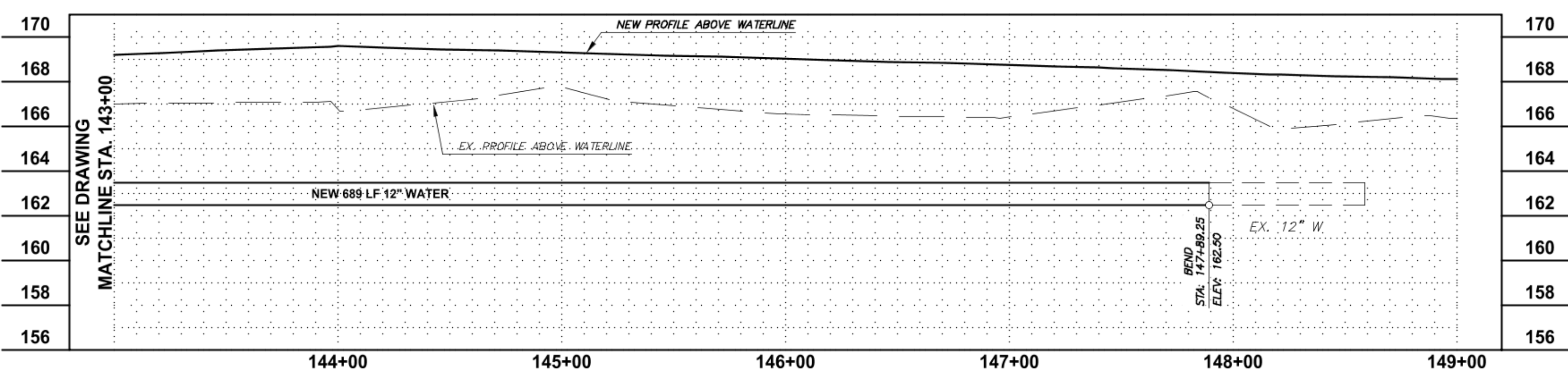
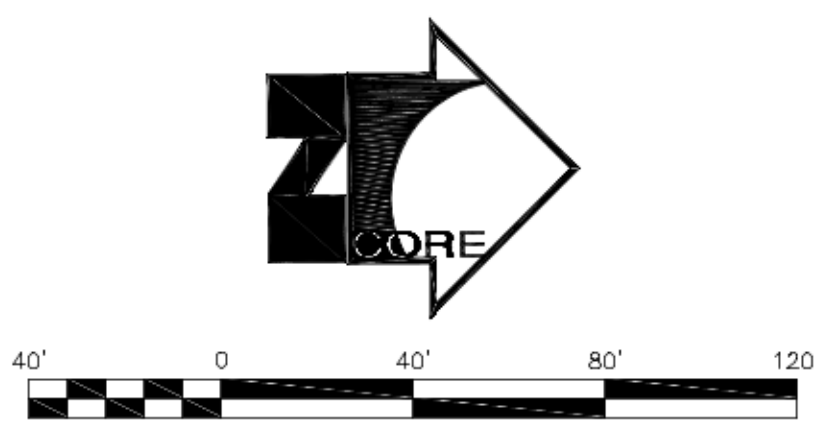
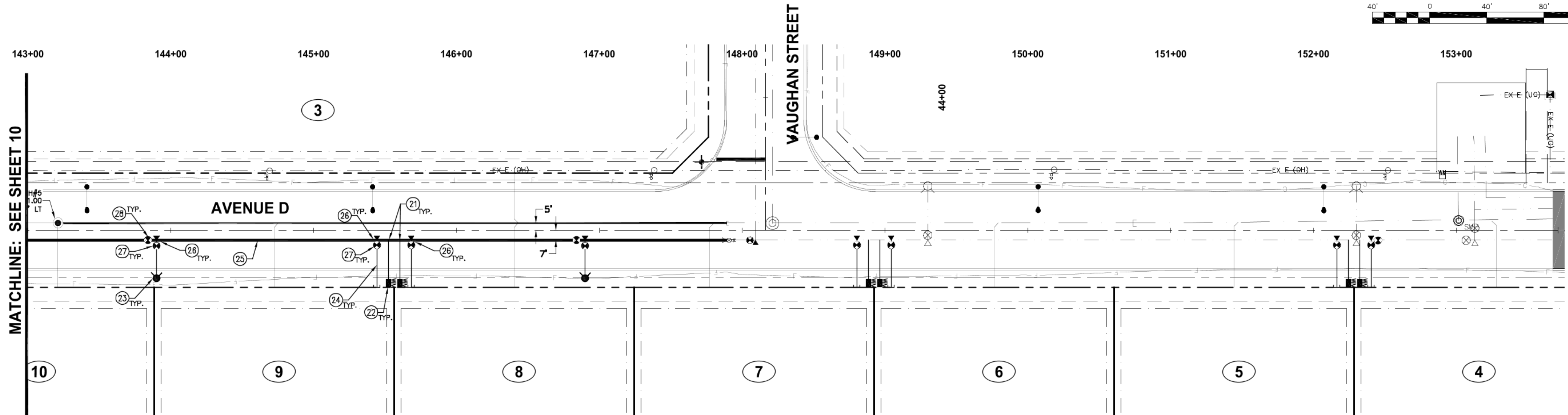

WATER SCHEDULE OF WORK

- 20 12" 45° BEND AND THRUST BLOCK (COST INCLUDED IN WATERLINE) -COY STD NO. 5-020
-COY STD NO. 5-025
- 21 1" SINGLE WATER SERVICE (COST INCLUDED IN ITEM 22) -COY STD NO. 5-035
-COY STD NO. 5-015
-SEE DETAIL A/B
- 22 1" SERVICE METER BOX -COY STD NO. 5-055
- 23 6" FIRE HYDRANT ASSEMBLY AND STREET MARKER -COY STD NO. 5-155
-COY STD NO. 5-160
- 24 6" CLASS 150 C900 PVC WATERLINE -COY STD NO. 5-010
- 25 12" CLASS 150 C900 PVC WATERLINE -COY STD NO. 5-010
- 26 12" X 12" X 6" TEE AND THRUST BLOCK (COST INCLUDED IN WATERLINE) -COY STD NO. 5-020
-COY STD NO. 5-025
- 27 6" GATE VALVE WITH ANCHOR, VALVE BOX, FRAME AND COVER -COY STD NO. 5-065
-COY STD NO. 5-075
- 28 12" GATE VALVE WITH ANCHOR, VALVE BOX, AND COVER -COY STD NO. 5-065
-COY STD NO. 5-075
- 29 CONNECT NEW 12" WATERLINE TO EXISTING
- 30 12" 90° BEND AND THRUST BLOCK (COST INCLUDED IN WATERLINE) -COY STD NO. 5-020
-COY STD NO. 5-025
- 31 WATERMAIN BLOWOFF -COY STD NO. 5-085

DRAWING RECORD:

| | |
|-----|------|
| No. | DATE |
| | |

CORE ENGINEERING GROUP, PLLC
 200 East 16th Street, Suite 150
 Yuma, AZ 85364
 V - 928-344-5931 F - 928-344-5932
 www.CoreEngineeringGroup.com
 Core@core-e-g.com

**MAGRINO INDUSTRIAL PARK
 UNIT NO. 3
 CITY OF SAN LUIS
 YUMA COUNTY, ARIZONA
 AVE D - WATER PLAN & PROFILE**

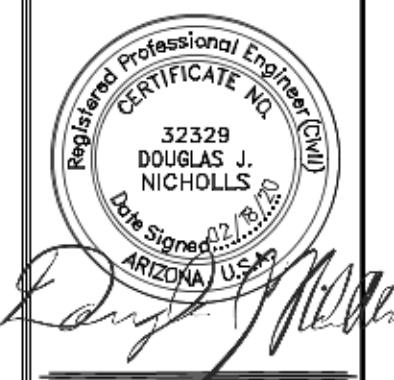

Date: DEC. 2019
 Designed: K.L.B.
 Drawn: J.M.G.
 Checked: D.J.N.
 Proj. No.: 19-096



UTILITY DISCLAIMER

THE UNDERGROUND UTILITIES SHOWN HAVE BEEN LOCATED FROM THE FIELD SURVEY INFORMATION AND EXISTING DRAWINGS. THE SURVEYOR MAKES NO GUARANTEE THAT THE UNDERGROUND UTILITIES SHOWN COMPRISE ALL SUCH UTILITIES IN THE AREA, EITHER IN SERVICE OR ABANDONED. THE SURVEYOR FURTHER DOES NOT WARRANT THAT THE UNDERGROUND UTILITIES SHOWN ARE IN THE EXACT LOCATION INDICATED ALTHOUGH HE DOES CERTIFY THAT THEY ARE LOCATED AS ACCURATELY AS POSSIBLE FROM INFORMATION AVAILABLE. THE SURVEYOR HAS NOT PHYSICALLY LOCATED THE UNDERGROUND UTILITIES.

Tue, 18 Feb 2020 - 3:38pm, Z:\2019\19-096\Draws\Final\Plat\19-096 Prelim Plat\19-096.dwg, Core Engineering Group, PLLC

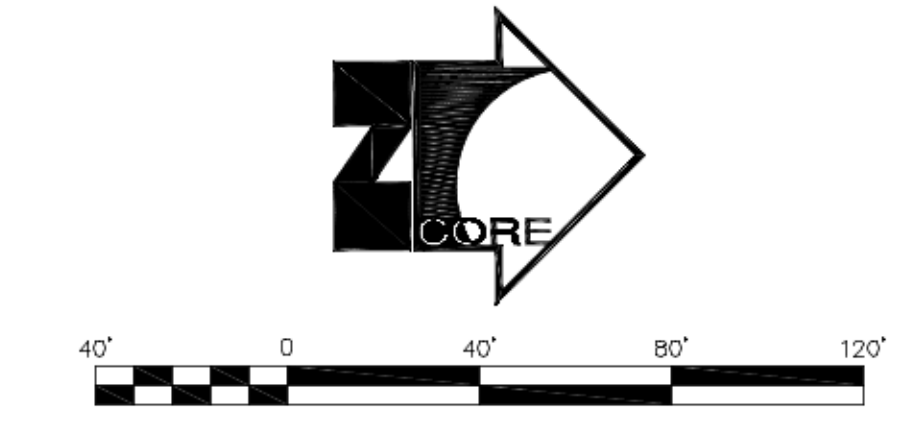
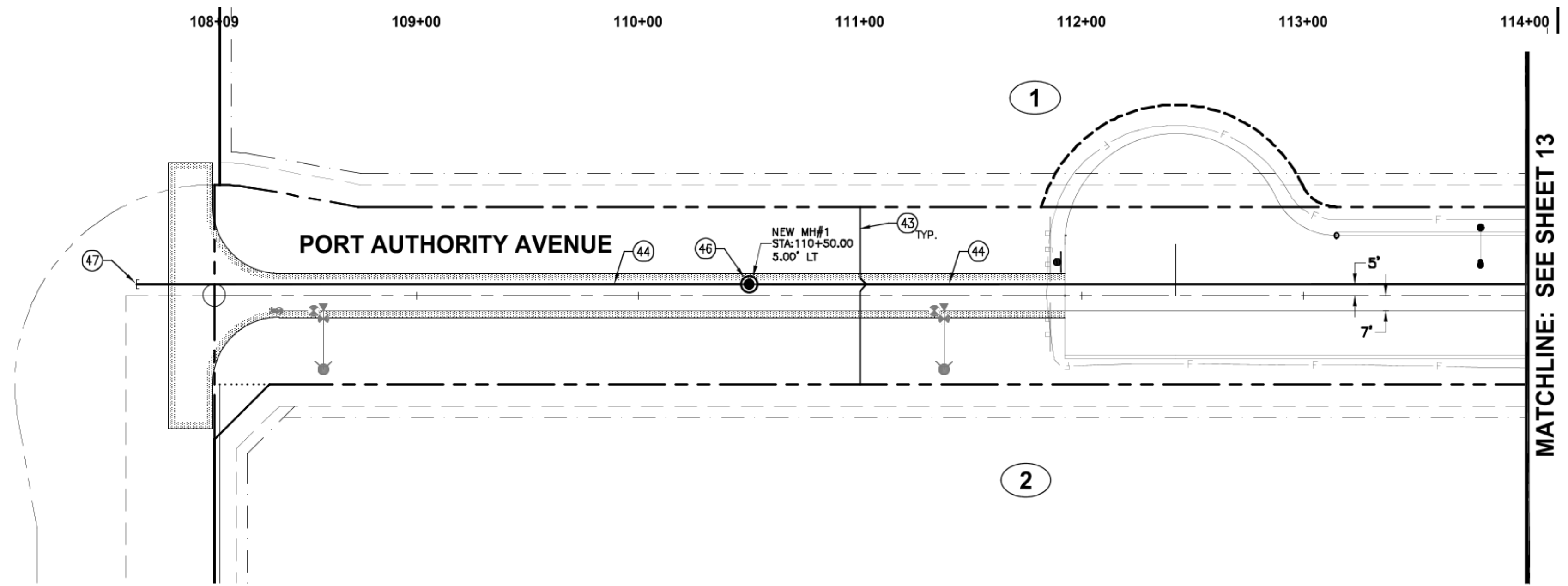

SEWER SCHEDULE OF WORK

- (1) 8" SDR 35 PVC SEWER LINE -COY STD NO. 5-010
- (2) 60" POLYMER MANHOLE -COY STD NO. 6-080
- (3) 6" SEWER SERVICE (TYP. ALL LOTS) -COY STD NO. 5-015
- (4) 10" SDR 35 PVC SEWER LINE -COY STD NO. 5-010
- (5) 8" WATER & SEWER CROSSING -COY STD NO. 5-005
- (6) 48" POLYMER MANHOLE -COY STD NO. 6-080 (SIM.)
- (7) WATERTIGHT CAP -COY STD NO. 6-090
- (8) ADJUST POLYMER MANHOLE TO FINAL GRADE -COY STD NO. 6-080

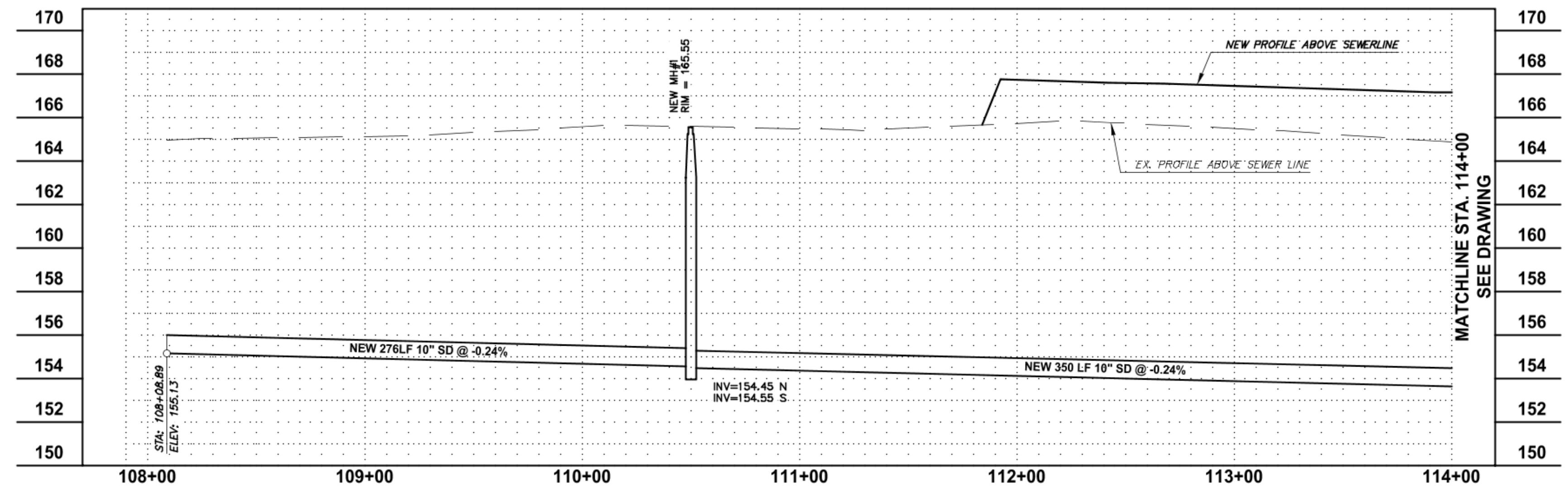

| | |
|-----------------|--|
| DRAWING RECORD: | |
| No. | |
| DATE: | |

CORE ENGINEERING GROUP, PLLC
 200 East 16th Street, Suite 150
 Yuma, AZ 85364
 V - 928-344-5931 F - 928-344-5932
 www.CoreEngineeringGroup.com
 Core@core-e-g.com

**MAGRINO INDUSTRIAL PARK
 UNIT NO. 3
 CITY OF SAN LUIS
 YUMA COUNTY, ARIZONA
 PORT AUTHORITY - SEWER PLAN & PROFILE**

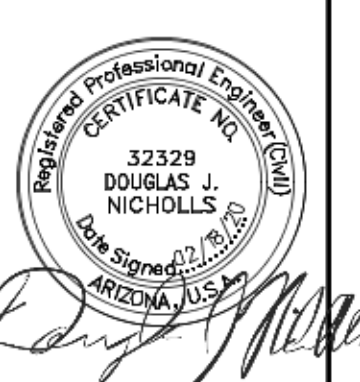

Date: DEC. 2019
 Designed: K.L.B.
 Drawn: J.M.G.
 Checked: D.J.N.
 Proj. No.: 19-096



UTILITY DISCLAIMER

THE UNDERGROUND UTILITIES SHOWN HAVE BEEN LOCATED FROM THE FIELD SURVEY INFORMATION AND EXISTING DRAWINGS. THE SURVEYOR MAKES NO GUARANTEE THAT THE UNDERGROUND UTILITIES SHOWN COMPRISE ALL SUCH UTILITIES IN THE AREA, EITHER IN SERVICE OR ABANDONED. THE SURVEYOR FURTHER DOES NOT WARRANT THAT THE UNDERGROUND UTILITIES SHOWN ARE IN THE EXACT LOCATION INDICATED ALTHOUGH HE DOES CERTIFY THAT THEY ARE LOCATED AS ACCURATELY AS POSSIBLE FROM INFORMATION AVAILABLE. THE SURVEYOR HAS NOT PHYSICALLY LOCATED THE UNDERGROUND UTILITIES.

Tue, 18 Feb 2020 - 3:39pm, Z:\2019\19-096\Draws\Frailim\Plat\19-096\Frailim_Plat\19-096.dwg, Core Engineering Group, PLLC

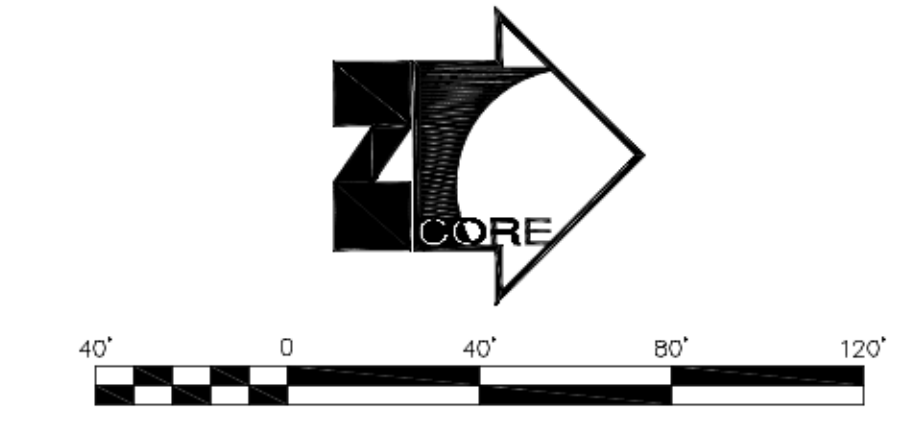
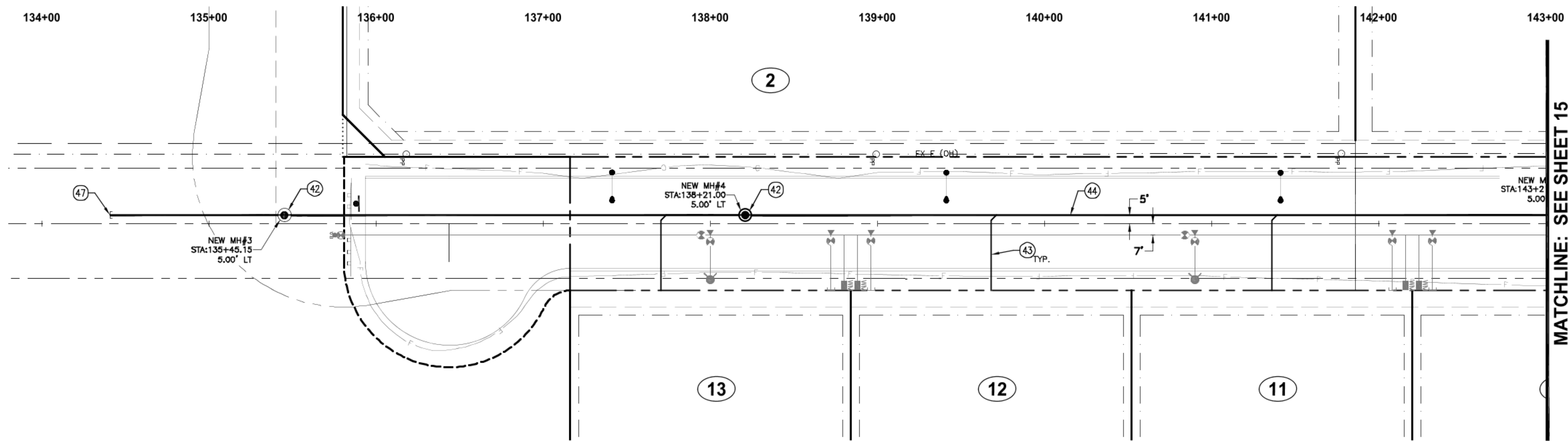

MATCHLINE: SEE SHEET 15

SEWER SCHEDULE OF WORK

- 41) 8" SDR 35 PVC SEWER LINE -COY STD NO. 5-010
- 42) 60" POLYMER MANHOLE -COY STD NO. 6-080
- 43) 6" SEWER SERVICE (TYP. ALL LOTS) -COY STD NO. 6-015
- 44) 10" SDR 35 PVC SEWER LINE -COY STD NO. 5-010
- 45) 8" WATER & SEWER CROSSING -COY STD NO. 5-005
- 46) 48" POLYMER MANHOLE -COY STD NO. 6-080 (SIM.)
- 47) WATERTIGHT CAP -COY STD NO. 6-090
- 48) ADJUST POLYMER MANHOLE TO FINAL GRADE -COY STD NO. 6-080

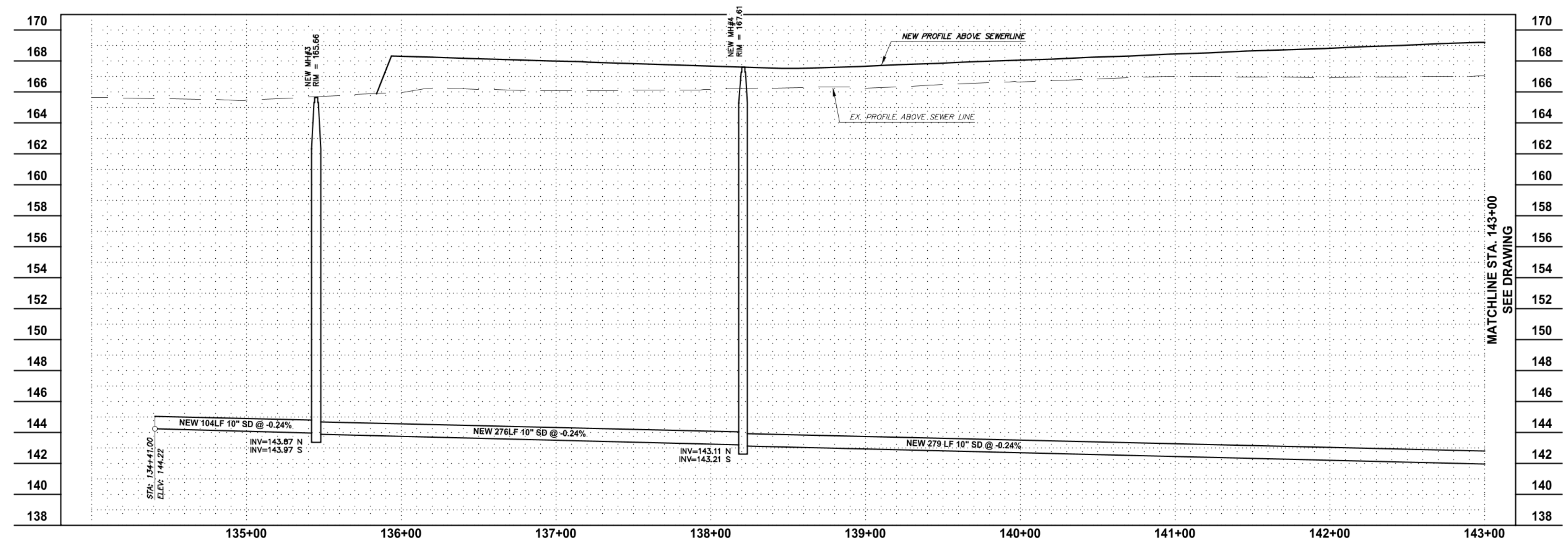

MATCHLINE STA. 143+00
SEE DRAWING

| | |
|-----------------|--|
| DRAWING RECORD: | |
| No. | |
| DATE: | |

CORE ENGINEERING GROUP, PLLC
 200 East 16th Street, Suite 150
 Yuma, AZ 85364
 V - 928-344-5931 F - 928-344-5932
 www.CoreEngineeringGroup.com
 Core@core-e-g.com

**MAGRINO INDUSTRIAL PARK
 UNIT NO. 3**
 CITY OF SAN LUIS
 YUMA COUNTY, ARIZONA
 AVE D - SEWER PLAN & PROFILE

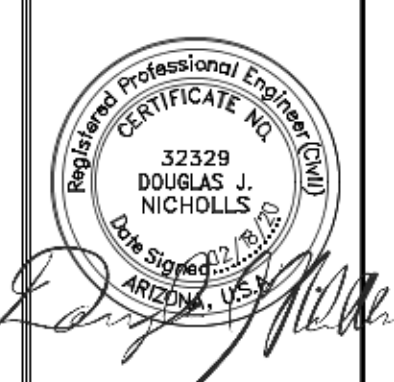

Date: DEC. 2019
 Designed: K.L.B.
 Drawn: J.M.G.
 Checked: D.J.N.
 Proj. No.: 19-096



UTILITY DISCLAIMER

THE UNDERGROUND UTILITIES SHOWN HAVE BEEN LOCATED FROM THE FIELD SURVEY INFORMATION AND EXISTING DRAWINGS. THE SURVEYOR MAKES NO GUARANTEE THAT THE UNDERGROUND UTILITIES SHOWN COMPRISE ALL SUCH UTILITIES IN THE AREA, EITHER IN SERVICE OR ABANDONED. THE SURVEYOR FURTHER DOES NOT WARRANT THAT THE UNDERGROUND UTILITIES SHOWN ARE IN THE EXACT LOCATION INDICATED ALTHOUGH HE DOES CERTIFY THAT THEY ARE LOCATED AS ACCURATELY AS POSSIBLE FROM INFORMATION AVAILABLE. THE SURVEYOR HAS NOT PHYSICALLY LOCATED THE UNDERGROUND UTILITIES.

Tue, 18 Feb 2020 3:40pm Z:\2019\19-096\Drawings\Profile Plot\Watsawk.dwg - Core Engineering Group, PLLC

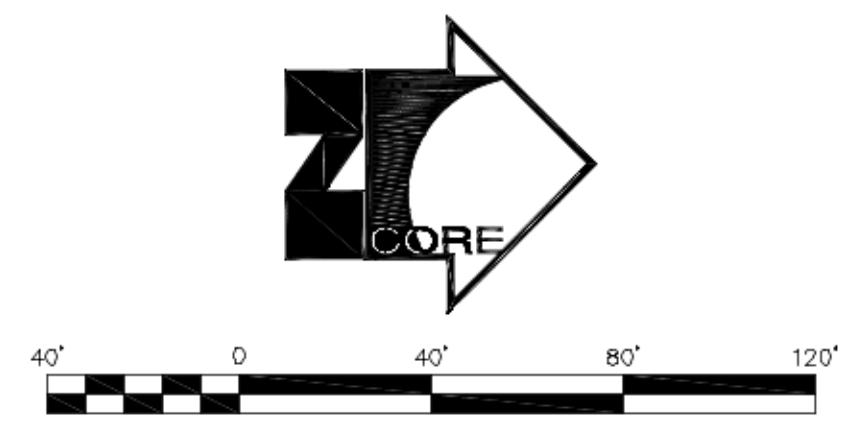
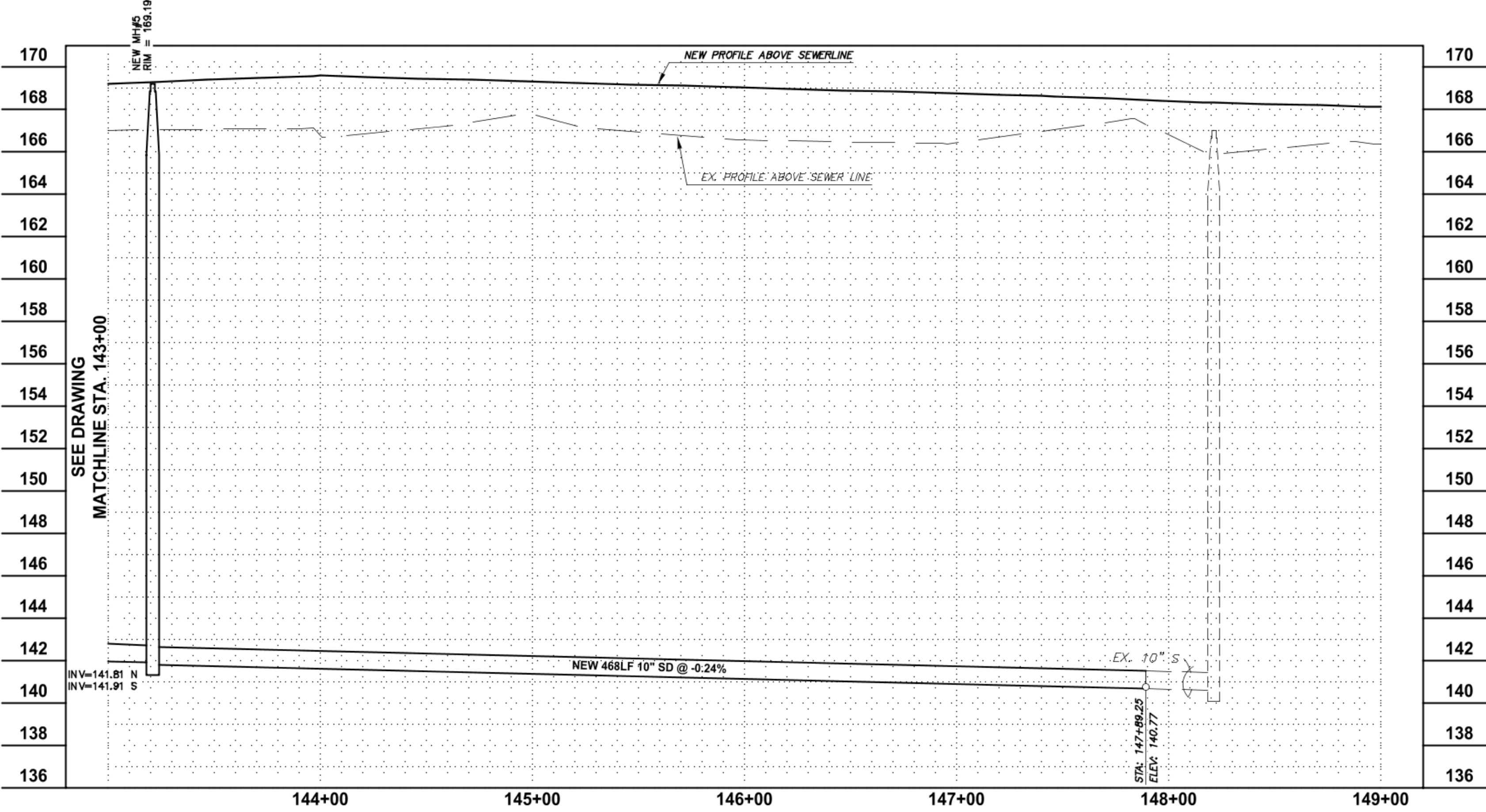
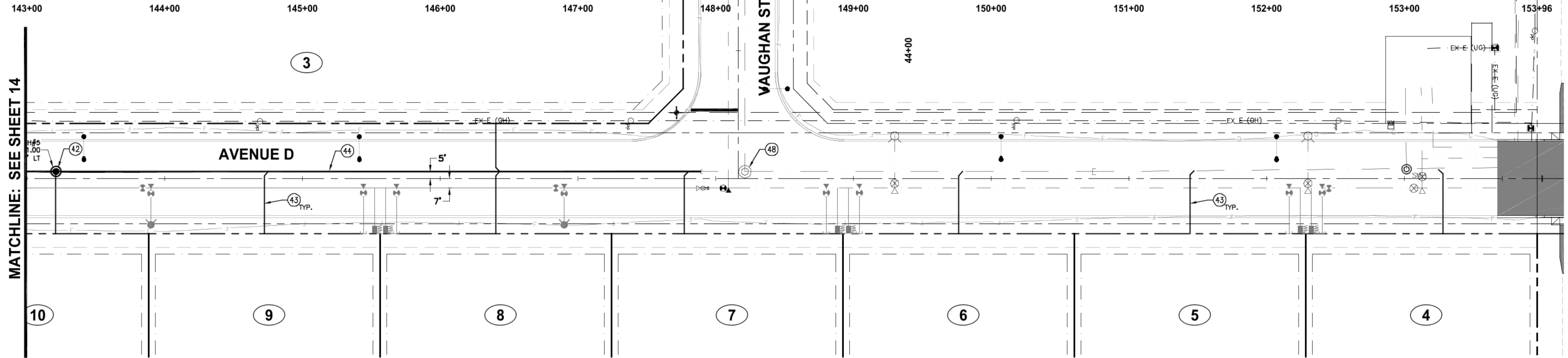

SEWER SCHEDULE OF WORK

- (41) 8" SDR 35 PVC SEWER LINE -COY STD NO. 5-010
- (42) 60" POLYMER MANHOLE -COY STD NO. 6-080
-COY STD NO. 6-090
- (43) 6" SEWER SERVICE (TYP. ALL LOTS) -COY STD NO. 6-015
-COY STD NO. 5-015
- (44) 10" SDR 35 PVC SEWER LINE -COY STD NO. 5-010
- (45) 8" WATER & SEWER CROSSING -COY STD NO. 5-005
- (46) 48" POLYMER MANHOLE -COY STD NO. 6-080 (SIM.)
-COY STD NO. 6-090
- (47) WATERTIGHT CAP
- (48) ADJUST POLYMER MANHOLE TO FINAL GRADE -COY STD NO. 6-080

UTILITY DISCLAIMER

THE UNDERGROUND UTILITIES SHOWN HAVE BEEN LOCATED FROM THE FIELD SURVEY INFORMATION AND EXISTING DRAWINGS. THE SURVEYOR MAKES NO GUARANTEE THAT THE UNDERGROUND UTILITIES SHOWN COMPRISE ALL SUCH UTILITIES IN THE AREA, EITHER IN SERVICE OR ABANDONED. THE SURVEYOR FURTHER DOES NOT WARRANT THAT THE UNDERGROUND UTILITIES SHOWN ARE IN THE EXACT LOCATION INDICATED ALTHOUGH HE DOES CERTIFY THAT THEY ARE LOCATED AS ACCURATELY AS POSSIBLE FROM INFORMATION AVAILABLE. THE SURVEYOR HAS NOT PHYSICALLY LOCATED THE UNDERGROUND UTILITIES.

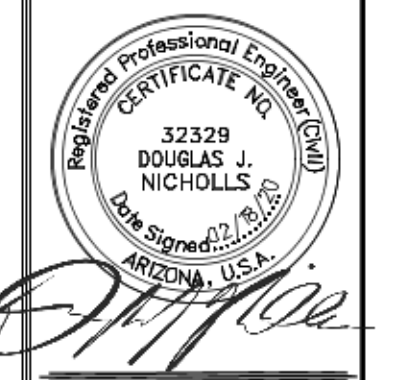

Date: DEC. 2019
 Designed: K.L.B.
 Drawn: J.M.G.
 Checked: D.J.N.
 Proj. No.: 19-096

CORE ENGINEERING GROUP, PLLC
 200 East 16th Street, Suite 150
 Yuma, AZ 85364
 V - 928-344-5931 F - 928-344-5932
 www.CoreEngineeringGroup.com
 Core@core-e-g.com

**MAGRINO INDUSTRIAL PARK
 UNIT NO. 3
 CITY OF SAN LUIS
 YUMA COUNTY, ARIZONA
 AVE D - SEWER PLAN & PROFILE**

DRAWING RECORD:
 No. _____
 DATE: _____

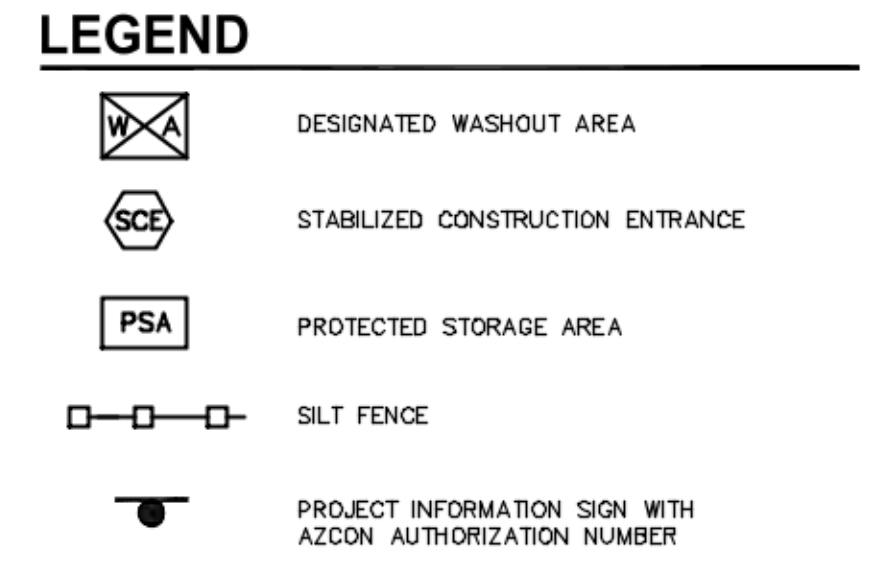
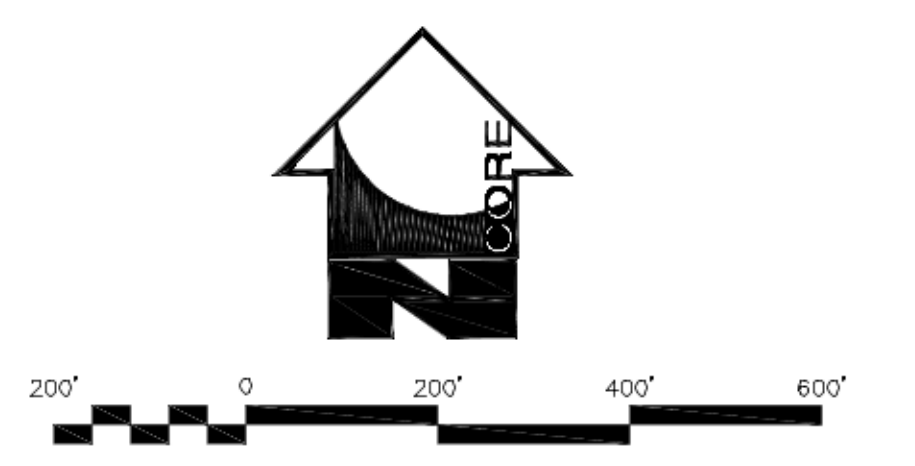

STORMWATER MANAGEMENT PLAN NOTES:

- AFTER PERMITS HAVE BEEN OBTAINED & EROSION CONTROL MEASURES INSTALLED, THE CONTRACTOR SHALL ROUGH GRADE SITE.
- CONTRACTOR SHALL PREVENT ANY SILTATION FROM ENTERING ANY STORM SEWER SYSTEM. ALL INLETS & INLET OPENINGS SHALL BE FULLY ENCLOSED WITH INLET PROTECTION DURING AND AFTER CONSTRUCTION OF INLET.
- NO LAND CLEARING OR GRADING SHALL BEGIN UNTIL ALL EROSION CONTROL MEASURES HAVE BEEN INSTALLED.
- ALL EXPOSED AREAS SHALL BE SEEDED AS SPECIFIED, WITHIN 7 DAYS OF FINAL GRADING.
- SHOULD CONSTRUCTION STOP FOR LONGER THAN 14 DAYS, THE SITE SHALL BE SEEDED AS SPECIFIED.
- MAINTAIN EROSION CONTROL MEASURES AT ALL TIMES ESPECIALLY BEFORE ANY PREDICTABLE RAIN.
- THIS PLAN SHALL NOT BE CONSIDERED ALL INCLUSIVE. AS THE CONTRACTOR SHALL TAKE ALL NECESSARY PRECAUTIONS TO PREVENT SOIL SEDIMENT FROM LEAVING THE SITE. THIS PLAN IS INTENDED TO BE UPDATED BY A QUALIFIED PERSON AS CONSTRUCTION ACTIVITIES PROCEED. METHODS OF EROSION CONTROL SHALL BE TAKEN FROM "DRAINAGE DESIGN FOR MARICOPA COUNTY, ARIZONA, VOLUME II EROSION CONTROL".
- CONTRACTOR SHALL COMPLY WITH ALL STATE AND LOCAL ORDINANCES THAT APPLY.
- ADDITIONAL EROSION AND SEDIMENT CONTROL MEASURES WILL BE INSTALLED IF DEEMED NECESSARY BY ON SITE INSPECTION.
- LAND DISTURBING ACTIVITIES SHALL NOT COMMENCE UNTIL APPROVAL TO DO SO HAS BEEN RECEIVED BY GOVERNING AUTHORITIES.
- ALL EXISTING STRUCTURES, FENCING, TREES, AND ETC., WITHIN CONSTRUCTION AREA SHALL BE REMOVED AND DISPOSED OF OFF SITE. ANY BURNING ON SITE SHALL BE SUBJECT TO LOCAL ORDINANCES.
- CONTRACTOR SHALL BE RESPONSIBLE TO TAKE WHATEVER MEANS NECESSARY TO ESTABLISH PERMANENT SOIL STABILIZATION.
- CONTRACTOR TO IDENTIFY, ON PLAN, AREAS THAT HAVE REACHED FINAL STABILIZATION.
- THE CONTRACTOR SHALL ADHERE TO THE SEQUENCE OF OPERATIONS FOR EROSION CONTROL IMPLEMENTATION HEREON. ANY DEVIATION FROM THIS SEQUENCE DEEMED NECESSARY BY THE CONTRACTOR SHALL BE APPROVED BY A QUALIFIED PERSONAL PERFORMING THE SITE SWPPP INSPECTIONS OR AS DESIGNATED IN SWPPP REPORT.
- THE GENERAL CONTRACTOR AND ALL SUBCONTRACTORS INVOLVED WITH CONSTRUCTION ACTIVITIES RELATED TO EROSION CONTROL AS SHOWN OR NOTED HEREON SHALL OBTAIN A COPY OF THE STORM WATER POLLUTION PREVENTION PLAN IN THE SITE WORK SPECIFICATIONS, AS WELL AS THE ARIZONA POLLUTANT DISCHARGE ELIMINATION SYSTEM (AZPDES) PERMIT FOR THIS SITE, AND BECOME FAMILIAR WITH THEIR CONTENTS.
- ALL WASH WATER SHALL BE DISPOSED OF IN A MANNER THAT PREVENTS CONTACT BETWEEN WASH WATER POLLUTANTS AND STORM RUNOFF DISCHARGED FROM THIS SITE.
- OIL AND GREASE ABSORBING MATERIALS SHALL BE READILY AVAILABLE ON SITE AND SHALL BE PROMPTLY USED TO CONTAIN AND/OR CLEAN UP ALL FUEL OR CHEMICAL SPILLS OR LEAKS.
- DUST CONTROL SHALL BE ACCOMPLISHED BY WATERING DRY, EXPOSED AREAS ON A REGULAR BASIS. SPRAYING OF PETROLEUM BASED OR TOXIC LIQUIDS FOR THIS IS PROHIBITED.
- DISTURBED AREAS OF THE SITE WHERE CONSTRUCTION ACTIVITIES HAVE CEASED FOR AT LEAST TWENTY-ONE DAYS SHALL BE TEMPORARILY SEEDED AND WATERED.
- DISTURBED AREAS OF THE SITE WHERE CONSTRUCTION ACTIVITIES HAVE PERMANENTLY CEASED SHALL BE PERMANENTLY SEEDED WITHIN FOURTEEN DAY PER LANDSCAPING SPECIFICATIONS.
- ALL VEHICLES SHALL BE CLEANED AT THE CONSTRUCTION EXIT POINTS ACCORDING TO NOTES SHOWN ON THE DETAIL THEREOF.
- ALL MATERIALS SPILLED, DROPPED, WASHED OR TRACKED ONTO ADJACENT ROADWAYS BY VEHICLES EXITING THE SITE SHALL BE CLEANED OR REMOVED IMMEDIATELY.
- THE CONTRACTOR SHALL BE RESPONSIBLE FOR PROMPT REMOVAL OF ALL ACCUMULATED SILT ALONG SITE PERIMETER.
- SILT FENCES SHALL BE PLACED AROUND ANY STOCKPILES USED ON THIS SITE.
- ANY ADDITIONAL EROSION CONTROL MEASURES REQUIRED TO ENSURE COMPLIANCE WITH THE ARIZONA POLLUTANT DISCHARGE ELIMINATION SYSTEM CONSTRUCTION GENERAL PERMIT REGULATIONS SHALL BE IMPLEMENTED BY THE CONTRACTOR, AT NO ADDITIONAL EXPENSE TO THE OWNER.
- ALL TEMPORARY EROSION CONTROL MEASURES SHALL BE REMOVED AND PROPERLY DISPOSED OF OFF-SITE WITHIN THIRTY DAYS AFTER STABILIZATION OF ALL SURFACES.
- THE CONTRACTOR SHALL ASSUME LIABILITY FOR DAMAGE TO ADJACENT PROPERTIES AND/OR PUBLIC RIGHT-OF-WAY RESULTING FROM FAILURE TO FULLY IMPLEMENT AND EXECUTE ALL EROSION CONTROL PROCEDURES SHOWN AND NOTED IN THESE PLANS.
- WHENEVER DIRT, ROCK, OR OTHER MATERIALS ARE EXPORTED FOR USE OFF OF THE PRIMARY CONSTRUCTION SITE, THE CONTRACTOR IS RESPONSIBLE FOR DETERMINING THAT STORM WATER PERMITTING REQUIREMENTS ARE MET, PRIOR TO ANY EXPORT OF MATERIALS. THE CONTRACTOR SHALL FURNISH THE ENGINEER WITH A WRITTEN AGREEMENT WITH ANY LANDOWNER WHO WILL RECEIVE EXPORTED MATERIALS, STATING THAT THE SITE WILL BE PROPERLY PERMITTED WHEN REQUIRED AND DESCRIBE THE EROSION CONTROL MEASURES WHICH WILL BE USED. AT A MINIMUM, EROSION CONTROL MEASURES MUST CONSIST OF PERIMETER CONTROLS (HAY BALES OR SILT FENCES) ON ALL DOWNSLOPES AND SIDESLOPE BOUNDARIES OF ANY DISTURBED AREA, PLUS PROVISIONS FOR REVEGETATION AFTER THE FILL MATERIALS ARE IN PLACE. SEE DRAINAGE DESIGN MANUAL FOR MARICOPA COUNTY, ARIZONA VOLUME II, EROSION CONTROL FOR METHODS OF STORM WATER CONTROL.
- GRADED AREAS AROUND THE PERIMETER MUST DRAIN AWAY FROM THE FACE OF SLOPE AT THE CONCLUSION OF EACH WORKING DAY SO THAT STORM WATER WILL REMAIN ONSITE. THE CONTRACTOR SHALL BE RESPONSIBLE AND SHALL TAKE NECESSARY PRECAUTIONS TO PREVENT PUBLIC TRESPASS ONTO AREAS WHERE IMPOUNDED WATER CREATES A HAZARDOUS CONDITION.

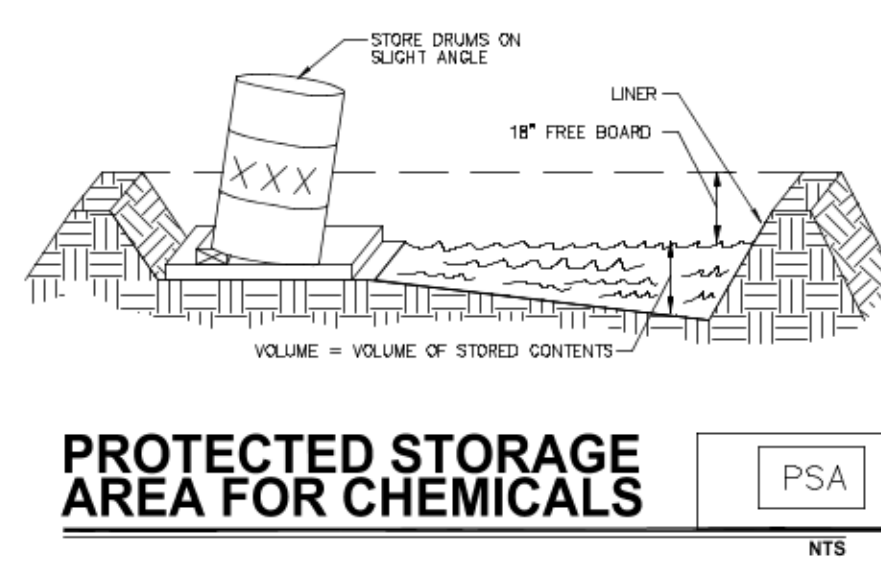

PROTECTED STORAGE AREA FOR CHEMICALS PSA

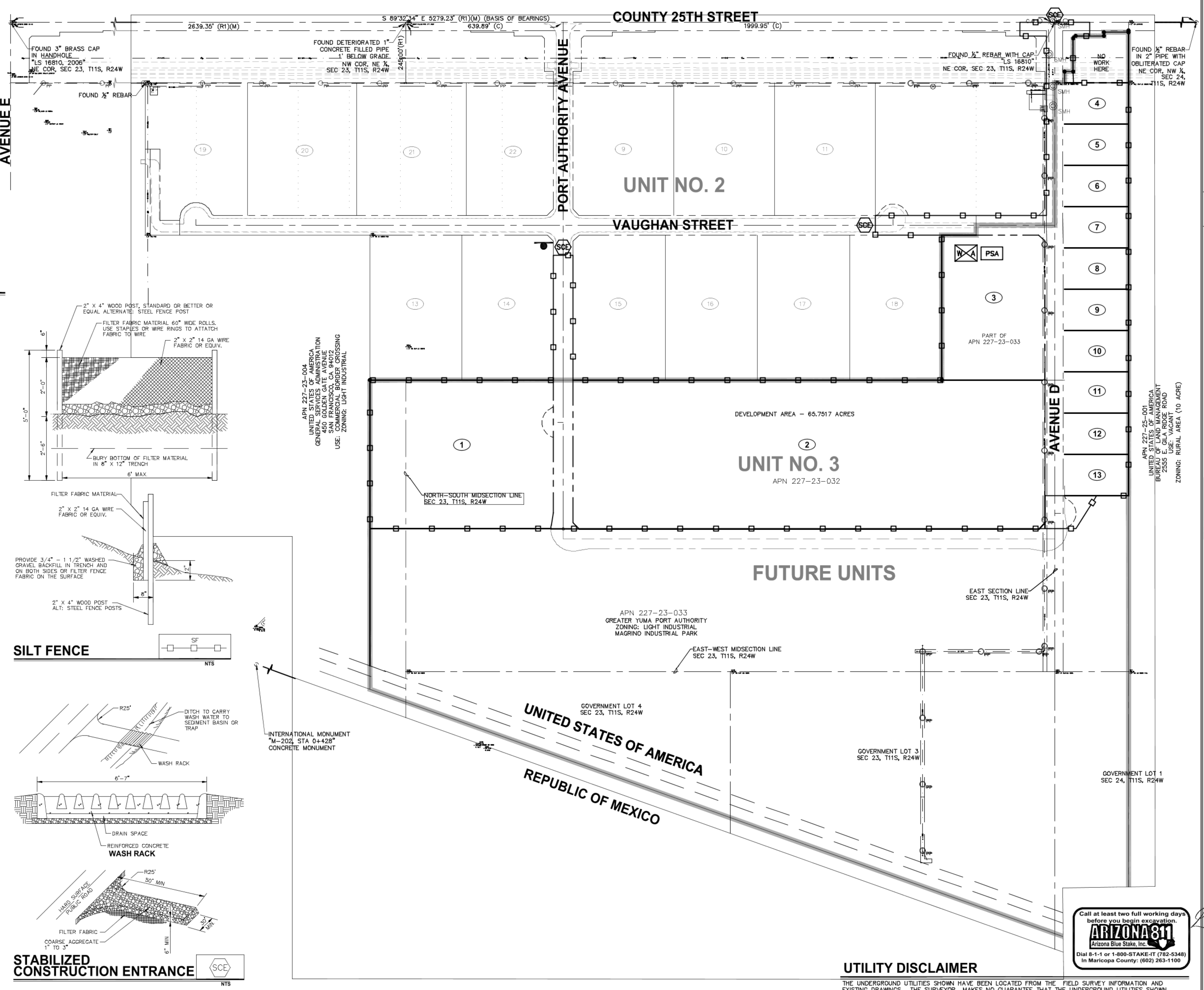

SILT FENCE NTS

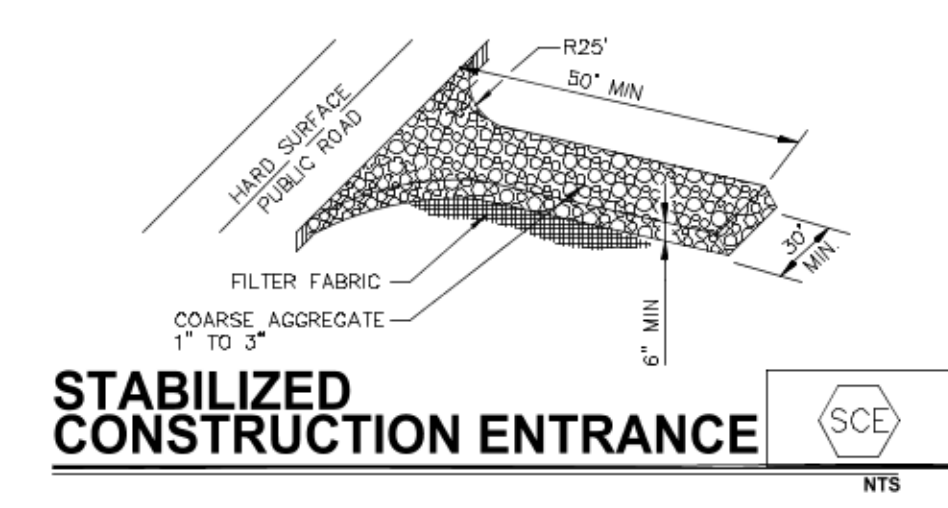
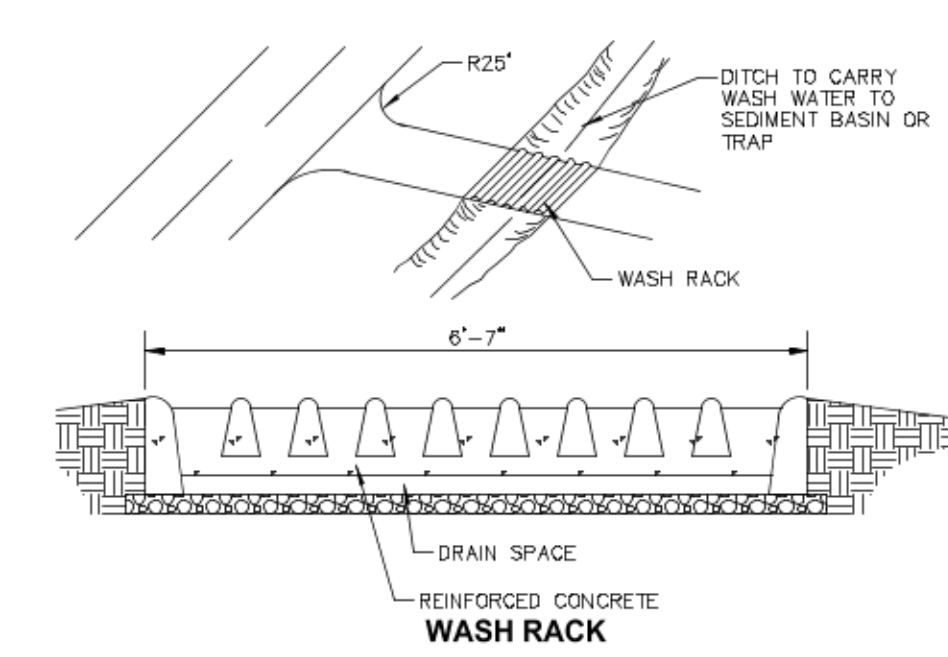

STABILIZED CONSTRUCTION ENTRANCE SCE

UTILITY DISCLAIMER

THE UNDERGROUND UTILITIES SHOWN HAVE BEEN LOCATED FROM THE FIELD SURVEY INFORMATION AND EXISTING DRAWINGS. THE SURVEYOR MAKES NO GUARANTEE THAT THE UNDERGROUND UTILITIES SHOWN COMPRISE ALL SUCH UTILITIES IN THE AREA, EITHER IN SERVICE OR ABANDONED. THE SURVEYOR FURTHER DOES NOT WARRANT THAT THE UNDERGROUND UTILITIES SHOWN ARE IN THE EXACT LOCATION INDICATED ALTHOUGH HE DOES CERTIFY THAT THEY ARE LOCATED AS ACCURATELY AS POSSIBLE FROM INFORMATION AVAILABLE. THE SURVEYOR HAS NOT PHYSICALLY LOCATED THE UNDERGROUND UTILITIES.

CORE ENGINEERING GROUP, PLLC
 200 East 16th Street, Suite 150
 Yuma, AZ 85364
 V - 928-344-5931 F - 928-344-5932
 www.CoreEngineeringGroup.com
 Core@core-eg.com

MAGRINO INDUSTRIAL PARK UNIT NO. 3
 CITY OF SAN LUIS
 YUMA COUNTY, ARIZONA
 STORMWATER POLLUTION PREVENTION PLAN

Call at least two full working days before you begin excavation.
ARIZONA 811
 Arizona Blue Stake, Inc.
 Dial 8-1-1 or 1-800-STAKE-IT (782-5348)
 In Maricopa County: (602) 263-1100

Date: DEC. 2019
 Designed: K.L.B.
 Drawn: J.M.G.
 Checked: D.J.N.
 Proj. No.: 19-096

DRAWING RECORD:
 No. _____ DATE: _____

THIS DRAWING AND THE DATA CONTAINED HEREON ARE THE PROPERTY OF CORE ENGINEERING GROUP, PLLC AND SHALL NOT BE USED, REPRODUCED OR TRANSMITTED WITHOUT THE PRIOR EXPRESS CONSENT OF THE COMPANY. NGR SHALL HAVE ANY DATA OR INFORMATION CONTAINED HEREON BE USED IN A MANNER INCONSISTENT WITH THE PRIOR EXPRESS WRITTEN AUTHORIZATION OF THE COMPANY.

32329
 DOUGLAS J. NICHOLLS
 Professional Engineer
 ARIZONA, USA

16
 SHEET

Greater Yuma EDC Regional Project Assessment System - Impact Summary
Operation of GYPA ESP Projects on San Luis

| Year | Economic and Real Estate Impacts | | | | | | Revenue Impacts | | |
|---------------|----------------------------------|-----------------|-------------|--------------------------------|----------------------|----------------------|----------------------|--------------------|--------------------|
| | Employment | Personal Income | Output | Non-Residential Square Footage | Supported Population | Supported Enrollment | Supported Households | Local Tax Revenues | State Tax Revenues |
| 2020 | 111 | \$3,449,041 | \$9,061,155 | 193,069 | 264 | 55 | 70 | \$1,818,640 | \$1,426,548 |
| Total: | | \$3,449,041 | \$9,061,155 | | | | | \$1,818,640 | \$1,426,548 |

Greater Yuma EDC Regional Project Assessment System - Project Summary

For the Years: 2020

Jobs and Payroll

| | |
|------------------------------|-------------|
| New direct jobs created | 91 |
| New direct payroll | \$2,830,282 |
| Average payroll per employee | \$31,102 |

Capital Investment

| | |
|----------------------------------|--------------|
| Value of new construction | \$24,000,000 |
| Value of new equipment purchases | \$7,500,000 |

Economic Impact*

| | |
|------------------------------|-------------|
| Total value economic impact | \$9,061,155 |
| Total new jobs supported | 111 |
| Total new payroll supported | \$3,449,041 |
| Household spending supported | \$3,035,156 |

Construction Impact

| | |
|---------------------------------|--------------|
| Total value construction impact | \$29,055,541 |
| Total new jobs supported | 215 |
| Total new payroll supported | \$9,183,389 |

New Tax Revenue (direct and indirect)***Local Taxes**

| | |
|--------------|-------------|
| Property | \$481,911 |
| Sales | \$1,224,838 |
| State Shared | \$77,761 |
| HURF | \$34,131 |

State Taxes

| | |
|---------------------|-------------|
| Sales | \$1,353,475 |
| Personal Income Tax | \$73,073 |

*** Includes jobs, payroll, output and tax revenues of companies assisted by the Greater Yuma EDC as well as secondary impacts at other local businesses. Report includes only impacts created in 2020. Additional impacts will be generated in future years.**

Greater Yuma EDC Regional Project Assessment System - Economic Impact by Type
Operation of GYPA ESP Projects on San Luis

| Impact Type | Year | Employment | Personal Income | Output |
|--------------------|---------------|-------------------|------------------------|---------------|
| Direct | 2020 | 91 | \$2,830,282 | \$6,861,205 |
| | Total: | | \$2,830,282 | \$6,861,205 |
| | <hr/> | | | |
| Supplier | 2020 | 13 | \$406,979 | \$1,162,977 |
| | Total: | | \$406,979 | \$1,162,977 |
| | <hr/> | | | |
| Consumer | 2020 | 7 | \$211,780 | \$1,036,973 |
| | Total: | | \$211,780 | \$1,036,973 |
| | <hr/> | | | |
| Total | 2020 | 111 | \$3,449,041 | \$9,061,155 |
| | Total: | | \$3,449,041 | \$9,061,155 |
| | <hr/> | | | |

**Greater Yuma EDC Regional Project Assessment System
Demographic Impact by Type**

Operation of GYPA ESP Projects in San Luis

| Impact Type | Year | Employment | Supported Population | Grade School Population | High School Population | Supported Households |
|--------------------|---------------|-------------------|-----------------------------|--------------------------------|-------------------------------|-----------------------------|
| Direct | 2020 | 91 | 216 | 34 | 10 | 57 |
| | Total: | | | | | |
| Supplier | 2020 | 13 | 32 | 5 | 2 | 8 |
| | Total: | | | | | |
| Consumer | 2020 | 7 | 16 | 3 | 1 | 4 |
| | Total: | | | | | |
| Total | 2020 | 111 | 264 | 42 | 13 | 70 |
| | Total: | | | | | |

Total Household Spending Impact**GYPA ESP Projects**

| Spending Type | Year: 2020 | Amount |
|---------------------------------------|-------------------|--------------------|
| Local Retail & Services | | \$861,984 |
| Groceries | | \$251,918 |
| Restaurants & Bars | | \$160,863 |
| Personal Services | | \$24,281 |
| Other Household Expenses | | \$36,422 |
| Housekeeping Supplies | | \$39,457 |
| Gas & Motor Oil | | \$163,898 |
| Vehicle Repairs | | \$42,492 |
| Drugs | | \$30,352 |
| Medical Supplies | | \$6,070 |
| Personal Care Products | | \$36,422 |
| Tobacco Products | | \$18,211 |
| Misc Services | | \$51,598 |
| Regional Retail & Services | | \$661,664 |
| Home repairs & maintenance | | \$69,809 |
| Home furnishings & appliances | | \$97,125 |
| Apparel & shoes | | \$109,266 |
| New cars and trucks | | \$78,914 |
| Used cars and trucks | | \$78,914 |
| Other vehicles | | \$9,105 |
| Medical services | | \$42,492 |
| Entertainment fees & admission | | \$63,738 |
| Audio visual equipment | | \$63,738 |
| Pets, toys, hobbies | | \$48,562 |
| Non-Site Based Expenditures | | \$1,511,508 |
| Mortgage expenses | | \$230,672 |
| Property taxes | | \$106,230 |
| Housing rent | | \$206,391 |
| Utilities | | \$221,566 |
| Vehicle finance charges | | \$18,211 |
| Vehicle insurance | | \$66,773 |
| Vehicle licenses | | \$27,316 |
| Public transportation | | \$30,352 |
| Health insurance | | \$100,160 |
| Life insurance | | \$18,211 |
| Education | | \$63,738 |
| Cash contributions | | \$103,195 |
| Pensions | | \$318,691 |
| TOTAL: | | \$3,035,156 |

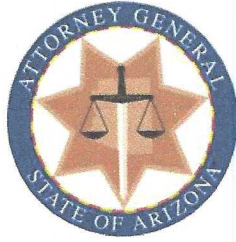

MARK BRNOVICH
ATTORNEY GENERAL

OFFICE OF THE ARIZONA ATTORNEY GENERAL
STATE GOVERNMENT DIVISION /
TRANSPORTATION SECTION

DAWN NORTHUP
DIVISION CHIEF COUNSEL
SUSAN E. DAVIS
ASSISTANT ATTORNEY GENERAL
DIRECT LINE: 602-542-8855
E-MAIL: SUSAN.DAVIS@AZAG.GOV

GRANT AGREEMENT
DETERMINATION

A.G. Contract No. P0012013003419 (MPD Agreement No. GRT-20-0008022-T), an Agreement between public agencies, the State of Arizona and the City of San Luis has been reviewed pursuant to A.R.S. § 28-7281, by the undersigned Assistant Attorney General who has determined that it is in the proper form and is within the powers and authority granted to the State of Arizona.

No opinion is expressed as to the authority of the remaining Parties, other than the State or its agencies, to enter into said Agreement.

DATED: January 21, 2021

MARK BRNOVICH
Attorney General

SUSAN E. DAVIS
Assistant Attorney General
Transportation Section

SED/sp/9232887

ADMINISTRATOR

Southwest Risk Services
14902 North 73rd Street
Scottsdale, AZ 85260
(602) 996-8810

THIS CERTIFICATE IS ISSUED AS A MATTER OF INFORMATION ONLY AND CONFERS NO RIGHTS UPON THE CERTIFICATE HOLDER. THIS CERTIFICATE DOES NOT AMEND, EXTEND OR ALTER THE COVERAGE AFFORDED BY THE POLICIES BELOW.

COMPANIES AFFORDING COVERAGE

INSURED

City of San Luis
PO Box 1170

San Luis, Arizona 85349

COMPANY
LETTER A ARIZONA MUNICIPAL RISK RETENTION POOL

COMPANY
LETTER B

COMPANY
LETTER C

COMPANY
LETTER D

COVERAGES

THIS IS TO CERTIFY THAT POLICIES OF INSURANCE LISTED BELOW HAVE BEEN ISSUED TO THE INSURED NAMED ABOVE FOR THE POLICY PERIOD INDICATED, NOT WITHSTANDING ANY REQUIREMENT, TERM OR CONDITION OF ANY CONTRACT OR OTHER DOCUMENT WITH RESPECT TO WHICH THIS CERTIFICATE MAY BE ISSUED OR PERTAIN, THE INSURANCE AFFORDED BY THE POLICES DESCRIBED HERE IN IS SUBJECT TO ALL THE TERMS, EXCLUSIONS, AND CONDITIONS OF SUCH POLICIES.

| CO LTR | TYPE OF INSURANCE | POLICY NUMBER | POLICY EFFECTIVE DATE (MM/DD/YY) | POLICY EXPIRATION DATE | LIMITS |
|--------|---------------------------------------------------------------------------------|---------------|----------------------------------|------------------------|---------------------------------------------------------------------------------------------------------------------------------------------------------------------------------------------------------|
| A | GENERAL LIABILITY X COMMERCIAL GENERAL LIABILITY X CLAIMS MADE OCCURRENCE | 2000169-4 | 7/1/2020 | 7/1/2021 | EACH WRONGFUL ACT \$2,000,000 PROD COMP/OPS AGGR \$2,000,000 GENERAL AGGREGATE \$6,000,000 PERSONAL & ADV INJURY \$2,000,000 FIRE DAMAGE(1 FIRE) \$300,000 MEDICAL EXP(1 PERSON) \$5,000 |
| A | AUTOMOBILE LIABILITY X ANY AUTO | 2000169-4 | 7/1/2020 | 7/1/2021 | COMBINED SINGLE LIMIT \$2,000,000 |
| A | EXCESS LIABILITY | 2000170-4 | 7/1/2020 | 7/1/2021 | EACH WRONGFUL ACT \$3,000,000 AGGREGATE \$3,000,000 |
| A | WORKERS' COMPENSATION AND EMPLOYERS' LIABILITY | 2000171-5 | 7/1/2020 | 7/1/2021 | STATUTORY (EACH ACCIDENT) \$1,000,000 (DISEASE-POL LMT) \$1,000,000 (DISEASE-EACH EMP) \$1,000,000 |
| A | OTHER | 2000169-4 | 7/1/2020 | 7/1/2021 | |

DESCRIPTION OF OPERATIONS/LOCATIONS/VEHICLES/SPECIAL ITEMS

State of Arizona, ADOT and its departments, agencies, boards, commissions, universities, officers, officials, agents and employees shall be named as additional insured's with respect to vicarious liability arising out of activities performed by or on behalf of the City/Town shown above as the Insured. This insurance if primary and subrogation against ADOT and the State of AZ is waived.

CERTIFICATE HOLDER

ADDITIONAL INSURED

State of Arizona
ADOT
1324 N 22nd Ave
Phoenix, Arizona 85009

CANCELLATION

SHOULD ANY OF THE ABOVE DESCRIBED POLICIES BE CANCELLED BEFORE THE EXPIRATION DATE THEREOF, THE ISSUING COMPANY WILL ENDEAVOR TO MAIL 30 DAYS WRITTEN NOTICE TO THE CERTIFICATE HOLDER NAMED TO THE LEFT BUT FAILURE TO MAIL SUCH NOTICE SHALL IMPOSE NO OBLIGATION OR LIABILITY OF ANY KIND UPON THE COMPANY, ITS AGENTS OR REPRESENTATIVES.

AUTHORIZED SIGNATURE





THIS ENDORSEMENT CHANGES THE COVERAGE AGREEMENT. PLEASE READ IT CAREFULLY.

**ARIZONA MUNICIPAL RISK RETENTION POOL
ADDITIONAL COVERED ENTITY ENDORSEMENT**

This endorsement modifies coverage provided under the following:

MUNICIPAL LIABILITY

Section V. is amended to include as a "member" any person or organization named as an Additional Member on a Certificate of Coverage on file with Southwest Risk Services, the designated administrator for the Arizona Municipal Risk Retention Pool, but only with respect to liability arising out of the operation, activity or specific contract shown.

Certificate Of Completion

Envelope Id: 9904194C0D3A4F32A04EF9B4AE3BF0CC

Status: Completed

Subject: Please DocuSign this Economic Strength Program (ESP) Agreement GRT-20-0008022-T

Source Envelope:

Document Pages: 67

Signatures: 4

Envelope Originator:

Certificate Pages: 6

Initials: 4

Sally J. Palmer

AutoNav: Enabled

206 S 17th Ave

Envelopeld Stamping: Enabled

Phoenix, AZ 85007

Time Zone: (UTC-07:00) Arizona

SPalmer@azdot.gov

IP Address: 64.207.219.137

Record Tracking

Status: Original

Holder: Sally J. Palmer

Location: DocuSign

12/22/2020 8:08:41 AM

SPalmer@azdot.gov

Signer Events

Ungyo Lynn Sugiyama

LUngyoSugiyama@azdot.gov

Security Level: Email, Account Authentication
(None)

Signature

Timestamp

Sent: 12/22/2020 8:17:34 AM

Viewed: 12/22/2020 12:29:41 PM

Signed: 12/22/2020 12:32:25 PM

Signature Adoption: Pre-selected Style

Using IP Address: 162.59.200.193

Electronic Record and Signature Disclosure:

Accepted: 12/22/2020 12:29:41 PM

ID: d15db67a-81ed-4e05-9ac8-6edd1bf6fc5b

Jenny Torres, Economic Development Manager

Jtorres@sanluisaz.gov

Security Level: Email, Account Authentication
(None)

Sent: 12/22/2020 12:32:27 PM

Resent: 1/20/2021 7:56:25 AM

Resent: 1/20/2021 8:06:26 AM

Viewed: 1/21/2021 9:29:05 AM

Signed: 1/21/2021 11:19:32 AM

Signature Adoption: Pre-selected Style

Using IP Address: 64.183.172.98

Electronic Record and Signature Disclosure:

Accepted: 1/21/2021 9:29:05 AM

ID: 7ed93ee0-82e7-4be0-8bc7-46cb83f25db1

AG Determination Processor

trncontracts@azag.gov

Security Level: Email, Account Authentication
(None)

Completed

Sent: 1/21/2021 11:19:35 AM

Viewed: 1/21/2021 12:39:20 PM

Signed: 1/21/2021 2:20:21 PM

Using IP Address: 159.87.87.61

Electronic Record and Signature Disclosure:

Accepted: 1/21/2021 12:39:20 PM

ID: c0fdbcb2b-7221-4f32-b0f1-b40bc073cd94

Kay Marion Macuil, City Attorney

Kmacuil@sanluisaz.gov

Security Level: Email, Account Authentication
(None)

DocuSigned by:
Kay Marion Macuil, City Attorney
BDF4259B52B5410...

Sent: 1/21/2021 2:20:24 PM

Viewed: 1/31/2021 7:24:38 AM

Signed: 1/31/2021 7:40:03 AM

Signature Adoption: Pre-selected Style

Using IP Address: 64.183.172.98

Electronic Record and Signature Disclosure:

Accepted: 1/31/2021 7:24:38 AM

ID: 4a327e92-3b2a-48fa-a40f-c5d37ec16fdb

Signer Events

Gerardo Sanchez, Mayor
Gsanchez@sanluisaz.gov
Mayor
Security Level: Email, Account Authentication (None)

Signature

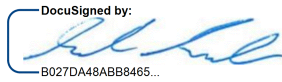

Signature Adoption: Uploaded Signature Image
Using IP Address: 64.183.172.98

Timestamp

Sent: 1/31/2021 7:40:05 AM
Viewed: 2/4/2021 3:24:05 PM
Signed: 2/4/2021 3:28:12 PM

Electronic Record and Signature Disclosure:
Accepted: 2/4/2021 3:24:05 PM
ID: 851988a1-c0b9-45d3-9f86-636db26b6c25

Maria Sabori, Risk Management Manager
msabori@sanluisaz.gov
Security Level: Email, Account Authentication (None)

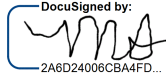

Signature Adoption: Drawn on Device
Using IP Address: 64.183.172.98

Sent: 2/4/2021 3:28:16 PM
Resent: 2/16/2021 9:01:22 AM
Viewed: 2/22/2021 9:13:12 AM
Signed: 2/23/2021 12:25:34 PM

Electronic Record and Signature Disclosure:
Accepted: 2/22/2021 9:13:12 AM
ID: a9fad93f-b62f-4525-8c22-9ca3c7252857

Gregory Byres, Division Director
GByres@azdot.gov
Multimodal Division Dir
ADOT
Security Level: Email, Account Authentication (None)



Signature Adoption: Pre-selected Style
Using IP Address: 69.244.26.97

Sent: 2/23/2021 12:25:38 PM
Viewed: 2/23/2021 12:27:15 PM
Signed: 2/23/2021 12:27:58 PM

Electronic Record and Signature Disclosure:
Not Offered via DocuSign

MPDAuthorization
mpdauthorization@azdot.gov
Security Level: Email, Account Authentication (None)



Signature Adoption: Pre-selected Style
Using IP Address: 98.165.104.128

Sent: 2/23/2021 12:28:01 PM
Viewed: 2/23/2021 2:48:05 PM
Signed: 2/26/2021 2:39:09 PM

Electronic Record and Signature Disclosure:
Accepted: 2/23/2021 2:48:04 PM
ID: d8e4afe9-f091-4880-8638-6fef86c2d256

In Person Signer Events **Signature** **Timestamp**

Editor Delivery Events **Status** **Timestamp**

Agent Delivery Events **Status** **Timestamp**

Intermediary Delivery Events **Status** **Timestamp**

Certified Delivery Events **Status** **Timestamp**

Carbon Copy Events **Status** **Timestamp**

Monica Castro, Finance Director
Mcastro@sanluisaz.gov
Security Level: Email, Account Authentication (None)



Sent: 2/26/2021 2:39:14 PM

Electronic Record and Signature Disclosure:
Not Offered via DocuSign

| Witness Events | Signature | Timestamp |
|-----------------------|------------------|------------------|
|-----------------------|------------------|------------------|

| Notary Events | Signature | Timestamp |
|----------------------|------------------|------------------|
|----------------------|------------------|------------------|

| Envelope Summary Events | Status | Timestamps |
|--------------------------------|---------------|-------------------|
|--------------------------------|---------------|-------------------|

| | | |
|---------------------|------------------|-----------------------|
| Envelope Sent | Hashed/Encrypted | 12/22/2020 8:17:34 AM |
| Certified Delivered | Security Checked | 2/23/2021 2:48:05 PM |
| Signing Complete | Security Checked | 2/26/2021 2:39:09 PM |
| Completed | Security Checked | 2/26/2021 2:39:14 PM |

| Payment Events | Status | Timestamps |
|-----------------------|---------------|-------------------|
|-----------------------|---------------|-------------------|

| Electronic Record and Signature Disclosure |
|---------------------------------------------------|
|---------------------------------------------------|

ELECTRONIC RECORD AND SIGNATURE DISCLOSURE

From time to time, Arizona Dept of Transportation (we, us or Company) may be required by law to provide to you certain written notices or disclosures. Described below are the terms and conditions for providing to you such notices and disclosures electronically through your DocuSign, Inc. (DocuSign) Express user account. Please read the information below carefully and thoroughly, and if you can access this information electronically to your satisfaction and agree to these terms and conditions, please confirm your agreement by clicking the 'I agree' button at the bottom of this document.

Getting paper copies

At any time, you may request from us a paper copy of any record provided or made available electronically to you by us. For such copies, as long as you are an authorized user of the DocuSign system you will have the ability to download and print any documents we send to you through your DocuSign user account for a limited period of time (usually 30 days) after such documents are first sent to you. After such time, if you wish for us to send you paper copies of any such documents from our office to you, you will be charged a \$0.00 per-page fee. You may request delivery of such paper copies from us by following the procedure described below.

Withdrawing your consent

If you decide to receive notices and disclosures from us electronically, you may at any time change your mind and tell us that thereafter you want to receive required notices and disclosures only in paper format. How you must inform us of your decision to receive future notices and disclosure in paper format and withdraw your consent to receive notices and disclosures electronically is described below.

Consequences of changing your mind

If you elect to receive required notices and disclosures only in paper format, it will slow the speed at which we can complete certain steps in transactions with you and delivering services to you because we will need first to send the required notices or disclosures to you in paper format, and then wait until we receive back from you your acknowledgment of your receipt of such paper notices or disclosures. To indicate to us that you are changing your mind, you must withdraw your consent using the DocuSign 'Withdraw Consent' form on the signing page of your DocuSign account. This will indicate to us that you have withdrawn your consent to receive required notices and disclosures electronically from us and you will no longer be able to use your DocuSign Express user account to receive required notices and consents electronically from us or to sign electronically documents from us.

All notices and disclosures will be sent to you electronically

Unless you tell us otherwise in accordance with the procedures described herein, we will provide electronically to you through your DocuSign user account all required notices, disclosures, authorizations, acknowledgements, and other documents that are required to be provided or made available to you during the course of our relationship with you. To reduce the chance of you inadvertently not receiving any notice or disclosure, we prefer to provide all of the required notices and disclosures to you by the same method and to the same address that you have given us. Thus, you can receive all the disclosures and notices electronically or in paper format through the paper mail delivery system. If you do not agree with this process, please let us know as described below. Please also see the paragraph immediately above that describes the consequences of your electing not to receive delivery of the notices and disclosures electronically from us.

How to contact Arizona Dept of Transportation:

You may contact us to let us know of your changes as to how we may contact you electronically, to request paper copies of certain information from us, and to withdraw your prior consent to receive notices and disclosures electronically as follows:

To advise Arizona Dept of Transportation of your new e-mail address

To let us know of a change in your e-mail address where we should send notices and disclosures electronically to you, you must send an email message to us at DocuSignRequest@azdot.gov and in the body of such request you must state: your previous e-mail address, your new e-mail address. We do not require any other information from you to change your email address.. In addition, you must notify DocuSign, Inc to arrange for your new email address to be reflected in your DocuSign account by following the process for changing e-mail in DocuSign.

To request paper copies from Arizona Dept of Transportation

To request delivery from us of paper copies of the notices and disclosures previously provided by us to you electronically, you must send us an e-mail to DocuSignRequest@azdot.gov and in the body of such request you must state your e-mail address, full name, US Postal address, and telephone number. We will bill you for any fees at that time, if any.

To withdraw your consent with Arizona Dept of Transportation

To inform us that you no longer want to receive future notices and disclosures in electronic format you may:

- i. decline to sign a document from within your DocuSign account, and on the subsequent page, select the check-box indicating you wish to withdraw your consent, or you may;
- ii. send us an e-mail to DocuSignRequest@azdot.gov and in the body of such request you must state your e-mail, full name, IS Postal Address, telephone number, and account number. We do not need any other information from you to withdraw consent.. The consequences of your withdrawing consent for online documents will be that transactions may take a longer time to process..

Required hardware and software

| | |
|----------------------------|----------------------------------------------------------------------------------------------------------------------------------------------------------------------------------------------|
| Operating Systems: | Windows2000? or WindowsXP? |
| Browsers (for SENDERS): | Internet Explorer 6.0? or above |
| Browsers (for SIGNERS): | Internet Explorer 6.0?, Mozilla FireFox 1.0, NetScape 7.2 (or above) |
| Email: | Access to a valid email account |
| Screen Resolution: | 800 x 600 minimum |
| Enabled Security Settings: | <ul style="list-style-type: none"> •Allow per session cookies •Users accessing the internet behind a Proxy Server must enable HTTP 1.1 settings via proxy connection |

** These minimum requirements are subject to change. If these requirements change, we will provide you with an email message at the email address we have on file for you at that time providing you with the revised hardware and software requirements, at which time you will have the right to withdraw your consent.

Acknowledging your access and consent to receive materials electronically

To confirm to us that you can access this information electronically, which will be similar to other electronic notices and disclosures that we will provide to you, please verify that you were able to read this electronic disclosure and that you also were able to print on paper or electronically save this page for your future reference and access or that you were able to e-mail this disclosure and consent to an address where you will be able to print on paper or save it for your future reference and access. Further, if you consent to receiving notices and disclosures exclusively in electronic format on the terms and conditions described above, please let us know by clicking the 'I agree' button below.

By checking the 'I Agree' box, I confirm that:

- I can access and read this Electronic CONSENT TO ELECTRONIC RECEIPT OF ELECTRONIC RECORD AND SIGNATURE DISCLOSURES document; and
- I can print on paper the disclosure or save or send the disclosure to a place where I can print it, for future reference and access; and
- Until or unless I notify Arizona Dept of Transportation as described above, I consent to receive from exclusively through electronic means all notices, disclosures, authorizations, acknowledgements, and other documents that are required to be provided or made available to me by Arizona Dept of Transportation during the course of my relationship with you.