



NOTICE OF REGULAR COUNCIL MEETING

In accordance with §38-431.02 of the Arizona Revised Statutes of the State of Arizona, notice is hereby given to the Members of City Council and to the general public that the Mayor and Council of the City of San Luis, Arizona will hold a Regular City Council meeting at 7:00 p.m., Wednesday, July 14, 2021. The meeting will take place at the City Council Chambers, located at 1090 E. Union Street, San Luis, Arizona, 85349. The public is invited to attend the open meeting.

In accordance with the Americans with Disabilities Act (ADA) and Section 504 of the Rehabilitation Act of 1973, the City of San Luis does not discriminate on the basis of disability in the admission of or access to, or treatment of employment in its programs, activities, or services. For information regarding rights and provisions of the ADA or Section 504, or to request reasonable accommodations for participation in City programs, activities or services contact: ADA/Section 504 Coordinator, City of San Luis Human Resources Department, 1090 E. Union Street, San Luis, Arizona, 85349; (928) 341-8520.

Notice is hereby given that pursuant to A.R.S. §1-602.A.9, subject to certain specified statutory exceptions, parents have a right to consent before the State or any of its political subdivisions make a video or audio recording of a minor child. Meetings of the City Council are audio and/or video recorded, and, as a result, proceedings in which children are present may be subject to such recordings. Parents in order to exercise their rights may either file written consent with the City Clerk to such recordings, or take personal action to ensure that their child or children are not present when a recording may be made. If a child is present at the time a recording is made, the City will assume that the rights afforded parents pursuant to A.R.S. §1-602.A.9 have been waived.

THIS NOTICE IS GIVEN BY:

/s/ Sonia Cornelio, City Clerk

AVISO DE JUNTA REGULAR

De acuerdo con los Estatutos del Estado de Arizona A.R.S. §38-431.02, se le informa a los miembros del Cabildo y al público en general que el Alcalde y el Cabildo, tendrán una Junta Regular a las 7:00 p.m., el día Miércoles, 14 de Julio del 2021. La junta se llevará a cabo en la Sala del Cabildo, ubicada en el 1090 E. Union Street, San Luis, Arizona, 85349. El público está cordialmente invitado a la junta.

De acuerdo con el Acta de Americanos con Discapacidades y la Sección 504 del Acta de Rehabilitación del 1973, la Ciudad de San Luis, Arizona no discrimina por causa de discapacidad la admisión y acceso a sus programas, actividades, servicios o en el trato en cuanto a empleo. Para más información referente a derechos y provisiones del Acta de Americanos con Discapacidades o Sección 504, o para solicitar adaptaciones que sean razonables para la participación en programas, actividades o servicios de la Ciudad, contactar al: Coordinador del Acta de Americanos con Discapacidades/Sección 504, Departamento de Recursos Humanos de la Ciudad de San Luis, Arizona, ubicado en el 1090 E. Union Street, San Luis, Arizona, 85349; (928) 341-8520.

Por medio de este aviso y de acuerdo con los Estatutos del Estado de Arizona A.R.S §1-602.A.9, sujeto a ciertas excepciones reglamentarias, los padres de familia tienen el derecho de dar el consentimiento ante el Estado o cualquiera de sus subdivisiones políticas para hacer una grabación de audio o video de su hijo menor de edad. Las juntas del Cabildo se graban en audio y/o video y como resultado, el hecho de que haya menores presentes puede ser sujeto a que sean grabados. Para que los padres de familia puedan ejercer sus derechos pueden dar el consentimiento por escrito con la Secretaria de la Ciudad a tal grabación, o tomar acción personal para asegurarse que su hijo menor no esté presente cuando la grabación se lleve a cabo. Si un menor de edad está presente en el momento de la grabación, la Ciudad asumirá que los padres de familia están cediendo los derechos sobre una posible grabación de acuerdo con los Estatutos del Estado de Arizona A.R.S. §1-602.A.9.

ESTE AVISO ES DADO POR:

/f/ Sonia Cornelio, Actuaría de la Ciudad



AMENDED AGENDA

7/13/2021

PREVIOUSLY ITEM NO. 5.B. HAS BEEN REMOVED AND RE-NUMBERED ACCORDINGLY

AGENDA

Regular Meeting

San Luis City Council

San Luis Council Chambers

1090 E. Union Street

San Luis, AZ 85349

July 14, 2021

7:00 p.m.

For the safety of the public during the COVID-19 pandemic, members of the public may attend the City Council's Regular Meeting of July 14, 2021 in person if the 6-foot distance can be maintained which is 27 people. However, members of the public may listen to the meeting's live audio stream on the City of San Luis' website <https://sanluisaz.gov/listenlive>. Recordings of the meetings will be available on the city's website <https://sanluisaz.gov/listenlive> after the meeting. Call to the Public will only be available to those attending the meeting in person.

PLEASE TAKE NOTICE THAT MEMBERS OF THE CITY COUNCIL WILL ATTEND EITHER IN PERSON, TELEPHONE, OR VIDEO CONFERENCE COMMUNICATION. THE MAYOR OR ACTING MAYOR FOR THIS MEETING MAY CHANGE THE ORDER OF THE ITEMS; IF AUTHORIZED BY LAW AND BY A MAJORITY VOTE OF A QUORUM OF CITY COUNCIL MEMBERS PRESENT, AN EXECUTIVE SESSION WILL BE HELD IMMEDIATELY FOLLOWING THE VOTE IN ACCORDANCE WITH A.R.S. §38-431.03(A) AND THE MEETING WILL BE TEMPORARILY RECESSED WHILE THE CITY COUNCIL RETIRES TO EXECUTIVE SESSION WHICH WILL NOT BE OPEN TO THE PUBLIC.

Por la seguridad del público durante la pandemia COVID-19, habrá asistencia en persona para los miembros del público en la Junta Regular del Cabildo del 14 de Julio del 2021, si la distancia de 6 pies puede mantenerse, que es de 27 personas. Sin embargo, los miembros del público pueden escuchar el audio en vivo de la reunión transmitido en el sitio web de la Ciudad de San Luis <https://sanluisaz.gov/listenlive>. Las grabaciones de las reuniones estarán disponibles en el sitio web de la ciudad <https://sanluisaz.gov/listenlive> después de la reunión. Llamado al Público estara disponible solo a quienes asistan a la junta en persona.

TENGA EN CUENTA QUE LOS MIEMBROS DEL CABILDO DE LA CIUDAD ASISTIRÁN EN PERSONA, TELÉFONO O COMUNICACIÓN POR VIDEO CONFERENCIA. EL ALCALDE O VICE-ALCALDE DE ESTA REUNIÓN PUEDE CAMBIAR EL ORDEN DE LOS TEMAS; SI ESTÁ AUTORIZADO POR LA LEY Y POR MAYORÍA DE VOTOS DE UN QUÓRUM DE MIEMBROS DEL CABILDO PRESENTES, SE LLEVARÁ A CABO UNA SESIÓN EJECUTIVA INMEDIATAMENTE DESPUÉS DE LA VOTACIÓN DE ACUERDO CON LOS ESTATUTOS DEL ESTADO DE ARIZONA A.R.S. §38-431.03 (A) Y LA REUNIÓN SERÁ TEMPORALMENTE RECESADA MIENTRAS EL CABILDO DE LA CIUDAD SE RETIRE A UNA SESIÓN EJECUTIVA QUE NO ESTARÁ ABIERTA AL PÚBLICO.

1. **CALL TO ORDER/ROLL CALL**

2. **PLEDGE OF ALLEGIANCE**

3. **INVOCATION**

4. **CONSENT AGENDA**

All matters are considered to be routine by the City Council and will be enacted by one motion. If discussion is desired, that item will be removed from the Consent Agenda and will be considered separately.

4. A. **MINUTES OF**

- Work Session held June 2, 2021
- Regular Council meeting held June 9, 2021
- Regular Council meeting held June 23, 2021

4. B. **DISBURSEMENTS FROM JUNE 15, 2021 TO JUNE 28, 2021**

Total Disbursements \$992,577.36

(Nine Hundred Ninety-Two Thousand, Five Hundred, Seventy-Seven Dollars and Thirty-Six Cents)

5. DISCUSSION AND POSSIBLE ACTION ITEMS:

5. A. Discussion and possible action on any and all matters regarding the purchase of a new 2022 Peterbilt Solid Waste Truck with Scorpion body (side-loader) for the Public Works Department's Solid Waste Division. **(James R. Einwaechter, Assistant Director of Public Works).**

5. B. Discussion and possible action on any and all matters regarding Resolution No. 2188. A resolution of the Mayor and City Council of the City of San Luis, Arizona amending section HR-4-03(A) of the City of San Luis Personnel Policies relating to holidays, adding Miguel Gonzalez Day in memory of our esteemed colleague lost due to the COVID-19 pandemic and in commemoration of the perseverance of the essential workers and first responders in continuing the services to the City of San Luis throughout the difficulties presented by the public health emergency. **(Mayor Gerardo Sanchez and Vice Mayor Africa Luna-Carrasco)**

6. SUMMARY OF CURRENT EVENTS

Events by Mayor, Council Members and/or City Manager pursuant to A.R.S. §38-431.02 (K).

7. CALL TO THE PUBLIC

This is the time for the public to comment. Members of the City Council may not discuss items that are not specifically identified on the agenda. Therefore, pursuant to A.R.S. §38-431.01 (H), action taken as a result of public comment will be limited to directing staff to study the matter, responding to any criticism or scheduling the matter for further consideration and decision at a later date.

8. ADJOURNMENT



AGENDA ITEM REVIEW FORM

Regular City Council Meeting

4. A.

Meeting Date: 07/14/2021

Summary

MINUTES OF

- Work Session held June 2, 2021
 - Regular Council meeting held June 9, 2021
 - Regular Council meeting held June 23, 2021
-

Attachments

6/2/2021 WS

6/9/2021 RCM

6/23/2021 RCM

MINUTES
Work Session
San Luis City Council
San Luis Council Chambers
1090 E. Union Street
June 2, 2021
6:30 p.m.

1. CALL TO ORDER/ROLL CALL

Mayor Gerardo Sanchez called the Work Session to order at approximately 6:46 p.m.

PRESENT: Mayor Gerardo Sanchez
Vice Mayor Africa Luna-Carrasco (remotely)
Council Member Mario Buchanan Jr.
Council Member Luis Cabrera
Council Member Jose Ponce
Council Member Matias Rosales
Council Member Gloria Torres

OTHERS PRESENT: Tadeo A. De La Hoya, City Administrator
Sonia Cornelio, City Clerk
Kay Marion Macuil, City Attorney
Axel Chayra, IT Technician
Derek Dueñas, IT Manager
Jorge Perez, Billing & Collections Manager
Jose L. Cisneros, Executive Assistant
Miguel Ramirez, Accountant
Monica Castro, Director of Finance
Richard Jessup, Chief of Police
Jesse Lopez, PPEP, Inc.
Manuel Castro, Gethsemani Food Ministry
Fernando Quiroz, Arizona Interagency Farmworkers Coalition, Inc. (remotely)
Genaro Soto, Resident
Luis Ramirez, Ramirez Advisor Inter-National (remotely)
Antonio Carrillo, Yuma County Arts and Cultural Group (remotely)
Buna George, Greater Yuma Port Authority
Julie Engel, Greater Yuma Economic Development Corporation (remotely)
Lizeth Chavez, Off-Road Expo Committee (remotely)
Nizzer Mendez, 4FrontED (remotely)
Paul Ward, Yuma Metropolitan Organization (remotely)

2. ITEMS FOR DISCUSSION ONLY:

2. Continuation of discussion, review, and possible direction to staff on any and all matters regarding the proposed City of San Luis Fiscal Year 2021-2022 Budget. (City Staff)

Mayor and City Council reviewed the budget listing for Fiscal Year 2021-2022, Contractual Services, Council Sponsorships/Pledges, and Dues and Subscriptions. Mayor and City Council proposed the following contributions. Representatives from the different agencies participated via Zoom or in-person.

Ramirez Advisors Inter-National, LLC

Mr. Tadeo A. De La Hoya, City Administrator, informed that Ramirez Advisors Inter-National, LLC, requested \$55,000.00, which is the same amount that has been proposed for fiscal year 2020-2021.

Mr. Luis Ramirez, Ramirez Advisors Inter-National, LLC, gave a brief update on the San Luis Port of Entry I Expansion.

Mayor Gerardo Sanchez and City Council thanked Mr. Ramirez for the presentation update and for advocating for the city. He directed staff to proceed with the proposed contribution as agreed by City Council.

Greater Yuma Economic Development Corporation (GYEDC)

Ms. Julie Engel, Executive Director of Greater Yuma Economic Development Corporation, explained that this year her agency is requesting an incremental increase of \$6,254.00 for a total amount of \$57,514.00.

Mayor Sanchez thanked Ms. Engel for working in conjunction with the city to bring jobs to San Luis and the entire Yuma County. He directed staff to proceed with the proposed contribution as agreed by City Council.

Greater Yuma Port Authority (GYPA)

Mayor Gerardo Sanchez stated that the same contribution to the GYPA had been paid for the last 20 years.

Ms. Buna George, GYPA Executive Director, presented the developments her organization has been working on.

Council Member Matias Rosales mentioned that he is hopeful that the cash will continue to go up; this will avoid additional requests to the city. He thanked the City of Yuma, Cocopah Indian Tribe, and the Yuma County further continued partnership.

Mayor Sanchez thanked GYPA for their contribution to the city. He directed staff to proceed with the proposed contribution as agreed by City Council.

Contractual Services

Portable Practical Educational Preparation (PPEP) Youthbuild Program

Mayor Gerardo Sanchez stated that the Youthbuild Program has proven the excellent service they provide to the community year after year, such as volunteer hours and helping with construction. He thanked Mr. Jesse Lopez, Youthbuild Program Coordinator, for his dedication and hard work. Mayor Sanchez directed staff to proceed with the proposed contribution as agreed by City Council.

Mr. Jesse Lopez, Youthbuild Program Coordinator, thanked Mayor and City Council for their continued contribution to the program.

Yuma Metropolitan Planning Organization (YMPO)

Mayor Gerardo Sanchez thanked YMPO for prioritizing city projects that are very much needed in the community.

Mr. Paul Ward, YMPO Executive Director, informed that the funding shown in the spreadsheet is not correct, as the amount has decreased. He explained that as part of the stimulus funds received from the Federal Transit Administration, CARES Act brings a zero local match. As a result, this lowers the contributions by member agencies by using as much of the funds received. He informed by decreasing said amount, the contribution will be brought down to \$7,917.26.

Mayor Gerardo Sanchez directed staff to proceed with the proposed new contribution as agreed by City Council members.

Yuma County Area Transit (YCAT)

Mayor Gerardo Sanchez mentioned that San Luis is the community that utilizes YCAT's transportation the most. He informed that throughout the pandemic YCAT was active and did not charge its users. He stated that YCAT is requesting an increase of \$17,643.25, which will bring the total proposed contribution to \$88,216.25.

Ms. Shelly Kreger, Transit Director, informed that the increase is part of the increase to Arizona Western College, silver route. She stated that to provide service in the family secret circulator and increase the entity dues needs to be done to match the federal funding to run the service.

Council Member Luis Cabrera asked if there is a possibility that a bus route to the new medical mall is added in the future.

Mr. Ralph Velez, City Consultant, replied that the board is in the process of approving a short-range transportation plan; the east of San Luis was not part of the plan for this reason, a board meeting was held. He added that the consultants were made aware of

not considering the industrial and residential growth and the medical mall. They responded that the previous consultant recommended that the route was not feasible for east San Luis. He mentioned that the board denied the study, so they will have to present it again with new recommendations. Mr. Velez added that the yellow route (San Luis) is the main route in the system. Although he mentioned that some of the routes are not feasible, the board is considering mixing routes. He stated that it is uncertain that the plan will include east San Luis; if not, then the city should have a plan b to have its own commuter system to and from the east to bring residents from that area to downtown San Luis.

Mayor Gerardo Sanchez thanked YCAT for the service to San Luis. He directed staff to proceed with the proposed contribution as agreed by City Council.

Amberly's Place

Ms. Tori Bourguignon, Executive Director, informed that there is a new crisis response advocate, which is a San Luis resident. She mentioned that the city's contribution helps the advocate and the transportation to transport victims back and forth. She added that Amberly's Place appreciates and is proud of partnering with San Luis and looks forward to continuing to provide services to the community.

Mayor Gerardo Sanchez thanked Amberly's Place for being present in the community and for the excellent job. He directed staff to proceed with the proposed contribution as agreed by City Council.

GYEDC Binational/4FrontED

Mr. Nazzer Mendez, Executive Director, mentioned that the increase of \$343.00 is part of the intergovernmental agreement with the city, stating that the increase on each entity is based on population. He added that he has been working hard in promoting the megaregion locally and internationally.

Mayor Gerardo Sanchez thanked Mr. Mendez for the excellent job. He directed staff to proceed with the proposed contribution as agreed by City Council.

Gethsemani Food Ministry

Mayor Gerardo Sanchez thanked Mr. Manuel Castro from Gethsemani Food Ministry for his work in the community. He commented that \$5,000.00 is minimal to the job is being done in the community.

Mr. Manuel Castro, Gethsemani Food Ministry, thanked Mayor, City Council, and the San Luis Police Department for their support. He informed that since the COVID-19 pandemic started, his ministry has organized 15 drive-thru to provide the community with food boxes. He stated that his ministry had distributed more than 500,000 lbs. of food every month. He added that the city's contribution had been well distributed.

Mayor Gerardo Sanchez suggested increasing \$2,000.00 to Gethsemani's contribution. The members of the City Council did not oppose Mayor Sanchez's suggested increase. He directed staff to proceed with the proposed contribution as agreed by City Council.

Agency	Approved Budget FY 2020-2021	Requested Increases by Agency FY 2021-2022	Proposed Contribution for FY 2021-2022
Ramirez Advisors Inter-National, LLC	\$55,000.00		\$55,000.00
Greater Yuma Economic Development Corporation	\$51,260.00	\$6,254.00	\$57,514.00
Greater Yuma Port Authority	\$50,000.00		\$50,000.00
Humane Society of Yuma	\$55,000.00	\$5,000.00	\$60,000.00
PPEP, Inc. (Youth Build)	\$30,000.00		\$30,000.00
Yuma Metropolitan Planning Organization	\$13,319.00	\$81.00	\$13,400.00
Yuma County Area Transit	\$70,573.00	\$17,643.25	\$88,216.25
News Paper Publications	\$25,000.00		\$25,000.00
JCG Technologies	\$6,462.00		\$6,462.00
Amberly's Place	\$42,000.00		\$42,000.00
GYEDC Binational/4FrontED	\$7,598.00	\$343.00	\$7,941.00
Gethsemani Food Ministry	\$5,000.00		\$7,000.00
TOTAL	\$411,212.00		\$437,533.25

Council Sponsorships/Pledges

ComicCon and San Luis Film Festival

Mr. Antonio Carrillo, Yuma County Arts and Cultural Group, commented that in the year 2020, the ComicCon was held virtually, just like the San Luis Film Festival and a drive-in movie for both events. He thanked the Mayor, City Council, and staff for the tremendous support that has been given to both events. He informed that this year 2021, the Film Festival will commemorate its 10th year. Furthermore, he added that vendors were present during the ComicCon event, a movie was played, and other entertainment for the participants. Mr. Carrillo commented that he would like to prepare a bigger event because of this year's celebration. Therefore, he requested an increase for the Film Festival.

Mayor Gerardo Sanchez stated that the city would match whatever amount the Film Festival collects from fundraising activities, just like the other entities do. He mentioned that entities should also show commitment. He directed staff to proceed with the proposed contribution as agreed by City Council.

Off-Road Expo

Ms. Lizeth Chavez, Off-Road Expo Committee Chair, informed that the tentative date for this year's Off-Road Expo is October 23, 2021. She mentioned that the committee has checked within Yuma County and San Luis Rio Colorado, Sonora, Mexico, if there will be any other event that will affect the participation in this event, and found that there is nothing plan around said date.

Mayor Gerardo Sanchez commented that this event had been a great success in the community and outside the community. He directed staff to proceed with the proposed contribution as agreed by City Council.

Arizona Interagency Farmworkers Coalition (AIFC)

Mr. Fernie Quiroz, Arizona Interagency Farmworker Coalition, informed that AIFC had used the funding to provide scholarships to students residing in San Luis, Arizona. During the last year, AIFC awarded \$22,000 in scholarships, from which ten (10) individuals were San Luis residents totaling \$8,000.

Mayor Gerardo Sanchez thanked Mr. Quiroz for the excellent service they provide to students in our community. He proposed increasing the contribution to \$5,000; there was no opposition from members of the City Council. He directed staff to proceed with the proposed contribution as agreed by City Council.

Yuma Regional Medical Center - Cancer Center

Mayor Gerardo Sanchez informed that the city received a letter from Yuma Regional Medical Cancer Center stating that they would not be requesting funds this year. But, this agency has reached out and asked if the city will be sponsoring one of their events. He suggested leaving the proposed contribution for this agency. City Council agreed with Mayor Sanchez; he directed staff to proceed with the proposed contribution as agreed by City Council.

Agency	Approved Budget FY 2020-2021	Requested Increases by Agency FY 2021-2022	Proposed Contribution for FY 2021-2022
Yuma Community Food Bank	\$25,000.00		\$25,000.00
Freedom Newspaper of SW AZ	\$650.00		\$650.00
Civic Donations	\$22,000.00		\$22,000.00
ComicCon	\$5,000.00		\$5,000.00
San Luis Film Festival	\$5,000.00		\$5,000.00
Off-Road Expo	\$10,000.00		\$10,000.00
Arizona Interagency Farmworkers Coalition	\$3,000.00		\$5,000.00
Yuma Regional Medical Center Cancer Center	\$5,000.00		\$5,000.00
TOTAL	\$75,650.00		\$77,650.00

Dues and Subscriptions

The Mayor and City Council agreed with the following contributions; staff was directed to proceed with the proposed contributions.

Western Arizona Economic Development District (WAEDD)

Mr. Tadeo A. De La Hoya, City Administrator, explained that this entity works in conjunction with 4FrontED and GYEDC. They are representatives for economic development in Yuma and La Paz Counties as all the tribes along with those counties. He informed that the contribution is prorated for three (3) years from 2020 through 2022 a total amount requested is \$3,569.00.

Agency	Approved Budget FY 2020-2021	Requested Increases by Agency FY 2021-2022	Proposed Contribution for FY 2021-2022
Arizona-Mexico Commission	\$1,500		\$1,500
Border Trade Alliance	\$10,000		\$10,000
Arizona League of Cities and Towns	\$22,385	\$695	\$23,080
NALEO	\$700		\$700
National League of Cities and Towns	\$849	\$1,111	\$1,960
Chamber of Commerce	\$1,500		\$1,500
The Sun	\$340	-\$170	\$170
Yuma County Chamber of Commerce	\$660		\$660
Western Arizona Economic Development District (WAEDD)	-		\$3,569
TOTAL	\$37,934		\$43,139

3. ADJOURNMENT

MOTION: Council Member Mario Buchanan Jr./Council Member Jose Ponce to adjourn the Work Session at approximately 8:30 p.m. Motion passed unanimously.

The vote was as follows:

Mayor Gerardo Sanchez	Aye
Vice Mayor Africa Luna-Carrasco	Aye
Council Member Mario Buchanan Jr.	Aye
Council Member Luis Cabrera	Aye
Council Member Jose Ponce	Aye
Council Member Matias Rosales	Aye
Council Member Gloria Torres	Aye

APPROVED:

Gerardo Sanchez, Mayor

ATTEST:

Sonia Cornelio, City Clerk

Certification

I hereby certify that the foregoing minutes are a true and correct copy of the Work Session minutes for the City Council of the City of San Luis, Arizona, held on June 2, 2021. I further certify that the meeting was duly called and held and that a quorum was present.

Sonia Cornelio, City Clerk

MINUTES
Regular Council Meeting
San Luis City Council
San Luis Council Chambers
1090 E. Union Street
June 9, 2021
7:00 p.m.

1. CALL TO ORDER/ROLL CALL

Mayor Gerardo Sanchez called the Regular City Council meeting to order at approximately 7:02 p.m.

Mayor, City Council, and some members of staff participated remotely.

PRESENT: Mayor Gerardo Sanchez
Vice Mayor Africa Luna-Carrasco
Council Member Mario Buchanan Jr.
Council Member Luis Cabrera
Council Member Jose Ponce
Council Member Matias Rosales
Council Member Gloria Torres

OTHERS PRESENT: Tadeo A. De La Hoya, City Administrator
Sonia Cornelio, City Clerk
Kay Marion Macuil, City Attorney
Angelica Roldan, Assistant Parks & Recreation Director
Derek Dueñas, I.T. Manager
Domingo Sosa, I.T. Department
Enrique Lopez, Assistant Fire Chief
Eulogio Vera, Director of Public Works
Jonathan Dumadag, I.T. Department
Jorge Perez, Billing & Collections Manager
Jose Luis Cisneros, Executive Assistant
Jose Guzman, Director of Planning & Zoning
Marco A. Santana, Police Lieutenant
Miguel Ramirez, Finance Department
Monica Castro, Director of Finance
Ralph Velez, City Consultant
Roula Encinas, Acting Assistant Director of Finance
Elizabeth Carpenter, Developer (remotely)
Esteban Rosales, Resident
Gary Snyder, Resident
Jorge Duarte, Resident
Jose Palencia, Developer (remotely)
Najeh Edais, Edais Engineering (remotely)
Vianey Vega, Vega & Vega Engineering (remotely)

2. PLEDGE OF ALLEGIANCE

Council Member Gloria Torres led the Pledge of Allegiance.

3. INVOCATION

Mr. Tadeo De La Hoya, City Administrator, led the invocation.

4. CONSENT AGENDA

4. A. MINUTES OF

MINUTES OF

- Regular Council meeting held May 12, 2021

- Special Council meeting held May 19, 2021

4. B. DISBURSEMENTS FROM MAY 18, 2021 TO JUNE 1, 2021

Total Disbursements \$1,059,434.31

(One Million, Fifty-Nine Thousand, Four Hundred Thirty-Four Dollars and Thirty-One Cents)

4. C. Discussion and possible action on any and all matters regarding the contract with Amberly's Place, Inc. for Fiscal Year 2021-2022. (Tadeo A. De La Hoya, City Manager)

4. D. Discussion and possible action on any and all matters regarding the annual contribution to the 4FrontED Binational Regional Program to promote education, infrastructure, tourism, and economic development. (Tadeo A. De La Hoya, City Manager)

4. E. Discussion and possible action on any and all matters regarding the contract with Gethsemani Food Ministry for Fiscal Year 2021-2022. (Tadeo A. De La Hoya, City Manager)

4. F. Discussion and possible action on any and all matters regarding the agreement with Greater Yuma Economic Development Corporation for Fiscal Year 2021-2022. (Tadeo A. De La Hoya, City Manager)

4. G. Discussion and possible action on any and all matters regarding the contribution to the Greater Yuma Port Authority, Inc. for Fiscal Year 2021-2022. (Tadeo A. De La Hoya, City Manager)

4. H. Discussion and possible action on any and all matters regarding the agreement with the Humane Society of Yuma for Fiscal Year 2021-2022. (Tadeo A. De La Hoya, City Manager)

4. I. Discussion and possible action on any and all matters regarding the proposed agreement with Portable Practical Education Preparation, Inc. (PPEP) for Fiscal Year 2021-2022. (Tadeo A. De La Hoya, City Manager)

4. J. Discussion and possible action on any and all matters regarding the contract with Ramirez Advisors Inter-National, LLC for Fiscal Year 2021-2022. (Tadeo A. De La Hoya, City Manager)

4. K. Discussion and possible action on any and all matters regarding a budget for a contribution to the transit fund for the Yuma County Area Transit (YCAT) Public Transportation Services. (Tadeo A. De La Hoya, City Manager)

4. L. Discussion and possible action on any and all matters regarding the dues to Yuma Metropolitan Planning Organization (YMPO) for Fiscal Year 2021-2021. (Tadeo A. De La Hoya, City Manager)

4. M. Discussion and possible action on any and all matters regarding the proposed agreement with Arizona Interagency Farmworkers Coalition, Inc for Fiscal Year 2021-2022. (Tadeo A. De La Hoya, City Manager)

4. N. Discussion and possible action on any and all matters regarding the approval of an agreement with the nonprofit corporation, Comité de Bien Estar, Incorporated for the Off-Road Expo event in San Luis, Arizona for Fiscal Year 2021-2022. (Tadeo A. De La Hoya, City Manager)

4. O. Discussion and possible action on any and all matters regarding the contract with Yuma Community Food Bank for Fiscal Year 2021-2022. (Tadeo A. De La Hoya, City Manager)

4. P. Discussion and possible action on any and all matters regarding approval of a contract with Yuma County Arts and Cultural Group for the 2022 Annual Blazing Desert ComicCon event in San Luis, Arizona for Fiscal Year 2021-2022. (Tadeo A. De La Hoya, City Manager)

4. Q. Discussion and possible action on any and all matters regarding approval of a contract with Yuma County Arts and Cultural Group for the San Luis Film Festival event in San Luis, Arizona for Fiscal Year 2021-2022. (Tadeo A. De La Hoya, City Manager)

4. R. Discussion and possible action on any and all matters regarding a budget for Yuma Regional Medical Center (YRMC) Cancer Center Hispanic Support Group, Inc., for Fiscal Year 2021-2022. (Tadeo A. De La Hoya, City Manager)

MOTION: Council Member Gloria Torres/Council Member Jose Ponce to approve the Consent Agenda as presented. Motion passed unanimously.

The vote was as follows:

Mayor Gerardo Sanchez	Aye
Vice Mayor Africa Luna-Carrasco	Aye
Council Member Mario Buchanan Jr.	Aye
Council Member Luis Cabrera	Aye
Council Member Jose Ponce	Aye
Council Member Matias Rosales	Aye
Council Member Gloria Torres	Aye

5. DISCUSSION AND POSSIBLE ACTION ITEMS:

5. A. Discussion and possible action on any and all matters regarding the waiving of formal purchase procedures under City Code-Purchasing §3.05.010 (H) for the rental of inflatable slides and related kid-friendly rentals from Poly's Party Rentals for the 4th of July Celebration. (Lizandro Galaviz, Director of Parks and Recreation)

Ms. Angelica Roldan, Assistant Parks & Recreation, stated that Poly's Party Rentals is a local company and is a sole source. This company has been working with the city for several years and provides what is needed for the event. She asked that the procurement procedures be waived.

MOTION: Council Member Jose Ponce/Vice Mayor Africa Luna-Carrasco to approve the rental of the kid-friendly attractions presented in the amount of \$6,460.64 and waive formal purchasing procedures. Motion passed unanimously.

The vote was as follows:

Mayor Gerardo Sanchez	Aye
Vice Mayor Africa Luna-Carrasco	Aye
Council Member Mario Buchanan Jr.	Aye
Council Member Luis Cabrera	Aye
Council Member Jose Ponce	Aye
Council Member Matias Rosales	Aye
Council Member Gloria Torres	Aye

5. B. Discussion and possible action on any and all matters regarding the approval to move forward with the estimate from ULTRA SHOW MAKERS, for sound, stage, and lighting for the 4th of July Celebration as well as to formally waive procurement code §3.05.010 (D). (Lizandro Galaviz, Director of Parks and Recreation)

Ms. Angelica Roldan, Assistant Parks & Recreation, mentioned that this item is for the sound, stage and lighting from Ultra Show Makers for the 4th of July celebration. Staff has worked with them in the past and asked the Mayor and City Council to waive the procurement code.

MOTION: Vice Mayor Africa Luna-Carrasco/Council Member Luis Cabrera to approve the purchase of Ultra Show Makers services in the amount of \$18,601.32 as presented and waive formal purchasing procedures. Motion passed unanimously.

The vote was as follows:

Mayor Gerardo Sanchez	Aye
Vice Mayor Africa Luna-Carrasco	Aye
Council Member Mario Buchanan Jr.	Aye
Council Member Luis Cabrera	Aye
Council Member Jose Ponce	Aye
Council Member Matias Rosales	Aye
Council Member Gloria Torres	Aye

5. C. Discussion and possible action on any and all matters regarding the contract between the City of San Luis and Sound Talent Group for a musical performance for the 4th of July Celebration event. (Lizandro Galaviz, Director of Parks & Recreation)

Ms. Angelica Roldan, Assistant Parks & Recreation Director, requested to continue this item to the next scheduled Council meeting as staff is still finalizing and working on the contract for the headliner band.

MOTION: Vice Mayor Africa Luna-Carrasco/Council member Mario Buchanan Jr. to continue this item to the next scheduled Council meeting. Motion passed unanimously.

The vote was as follows:

Mayor Gerardo Sanchez	Aye
Vice Mayor Africa Luna-Carrasco	Aye
Council Member Mario Buchanan Jr.	Aye
Council Member Luis Cabrera	Aye
Council Member Jose Ponce	Aye
Council Member Matias Rosales	Aye
Council Member Gloria Torres	Aye

5. D. Public hearing followed by discussion and possible action on any and all matters regarding the recommendation of a Special Event Liquor License application to the Arizona Department of Liquor Licenses and Control to authorize the San Luis FRONTERA Rotary Club to sell alcohol at the 4th of July Celebration to be held July 4, 2021. (Lizandro Galaviz, Director of Parks and Recreation)

A. Open public hearing

MOTION: Council Member Mario Buchanan Jr./Council Member Jose Ponce to open the public hearing. Motion passed unanimously.

The vote was as follows:

Mayor Gerardo Sanchez	Aye
Vice Mayor Africa Luna-Carrasco	Aye
Council Member Mario Buchanan Jr.	Aye
Council Member Luis Cabrera	Aye
Council Member Jose Ponce	Aye
Council Member Matias Rosales	Aye
Council Member Gloria Torres	Aye

1. Presentation by staff and/or applicant

Ms. Angelica Roldan, Assistant Parks & Recreation Director, said that the FRONTERA Rotary Club requested to sell alcohol at the 4th of July event which will be held on Sunday, July 4 from 6:00 p.m. to midnight at Joe Orduño Park.

2. Call to the public on this item

Ms. Sonia Cornelio, City Clerk, indicated she did not receive any speaker request form for this item.

B. Close public hearing

MOTION: Council Member Mario Buchanan Jr./Council Member Jose Ponce to close the public hearing. Motion passed unanimously.

The vote was as follows:

Mayor Gerardo Sanchez	Aye
Vice Mayor Africa Luna-Carrasco	Aye
Council Member Mario Buchanan Jr.	Aye
Council Member Luis Cabrera	Aye
Council Member Jose Ponce	Aye
Council Member Matias Rosales	Aye
Council Member Gloria Torres	Aye

C. Action on Special Event Liquor License Application to the Arizona Department of Liquor Licenses & Control

MOTION: Council Member Matias Rosales/Council Member Mario Buchanan Jr. to recommend approval to the Arizona Department of Liquor Licenses and Control for the Special Event Liquor License application to the San Luis FRONTERA Rotary Club as presented. Motion passed unanimously.

The vote was as follows:

Mayor Gerardo Sanchez	Aye
Vice Mayor Africa Luna-Carrasco	Aye
Council Member Mario Buchanan Jr.	Aye
Council Member Luis Cabrera	Aye
Council Member Jose Ponce	Aye
Council Member Matias Rosales	Aye
Council Member Gloria Torres	Aye

5. E. Discussion and possible action on any and all matters regarding the approval of Lighting and Retention Basin Assessment Districts Budget for Fiscal Year 2021-2022. (Roula Encinas, Acting Assistant Director of Finance)

Ms. Roula Encinas, Acting Assistant Director of Finance, explained that these assessment districts were formed to provide street lighting and retention basin maintenance services in the developments. The County of Yuma requires City Council's approval for the budget in order to levy the assessments. The amounts are based on the estimated cost the city will incur to provide these services. She also clarified that these charges are not property tax; the City of San Luis does not have property tax. There is a misconception that these charges are property tax as they are collected by the Assessor's Office through the tax statement notice of value.

Mayor Gerardo Sanchez asked if there has been an increase from last year.

Ms. Encinas replied there has been an increase of 33.27% which is \$156,435.00 due to the five (5) new subdivisions and the water consumption.

Council Member Matias Rosales asked if Comite de Bienestar 9C is part of Comite de Bienestar 9B or if it is not noted for a reason.

Council Member Luis Cabrera asked if that is the reason Comite de Bienestar 9B has a very high amount.

Mr. Jose Guzman, Director of Planning & Zoning, responded that the Comite de Bienestar 9B retention basin did not change and when the Comite de Bienestar 9C subdivisions was completed, the retention went to the same retention basin of Comite de Bienestar 9B.

MOTION: Council Member Matias Rosales/Council Member Mario Buchanan Jr. to approve the 2021-2022 Fiscal Year Budget in the amount of \$626,578.00 for the Lighting and Retention Basin Assessment Districts. Motion passed unanimously.

The vote was as follows:

Mayor Gerardo Sanchez	Aye
Vice Mayor Africa Luna-Carrasco	Aye
Council Member Mario Buchanan Jr.	Aye
Council Member Luis Cabrera	Aye
Council Member Jose Ponce	Aye
Council Member Matias Rosales	Aye
Council Member Gloria Torres	Aye

5. F. Discussion and possible action on any and all matters regarding the acceptance and approval of the Tentative Budget for Fiscal Year 2021-2022. (Monica Castro, Director of Finance)

Ms. Monica Castro, Director of Finance, stated that per state statute, the Mayor and City Council is required to adopt a tentative budget to set the maximum expenditure limit for the next fiscal year upon adoption of the budget, the Mayor and City Council can reallocate expenditures or decrease the budget but it cannot be increased. It is also required that the tentative budget be published in the local newspaper within the next two (2) weeks asking the public to submit their comments for the public hearing that is scheduled for June 23rd. She added that on April 16th and 17th the budget retreat took place and a draft of the budget was introduced to the Mayor and City Council. The Mayor and City Council were able to comment, make recommendations and staff worked on the tentative budget. Ms. Castro explained the spreadsheet and PowerPoint illustrated during the City Council meeting, which are included with the complete agenda packet at the City Clerk's Office. She briefly described the items that were added after the budget retreat which is one full-time position for the Senior Center and the Capital Projects such as the construction for Phase 1 of the Police substation, expansion and design for the City Hall west wing, matching funds for the bill grant for the Cesar Chavez Boulevard including the street lining and widening design.

Mayor Gerardo Sanchez commented that every year is a challenge, especially with the pandemic however businesses will now be opening. But the assistance by the federal government will go away.

Council Member Jose Ponce asked how the city is doing with the FEMA response in regards to the COVID-19.

Ms. Castro responded that the answer with FEMA has not been good, it has been a difficult process, if the city has been reimbursed \$20,000.00, that would be a lot. The city has used more resources than what is being received and staff is in the process of trying one (1) more time. However, this is a small city and putting in too many resources to get it, might not be worth it since there are other grants that the city can utilize.

Mayor Gerardo Sanchez said that FEMA is behind since all municipalities are applying for reimbursement. However, the city's budget does not depend on FEMA's reimbursement.

There were some discussion between some City Council members and Ms. Castro regarding the detention center and the Senior Center position requested.

MOTION: Vice Mayor Africa Luna-Carrasco/Council Member Luis Cabrera to approve the tentative budget for the Fiscal Year 2021-2022 as presented. Motion passed unanimously.

The vote was as follows:

Mayor Gerardo Sanchez	Aye
Vice Mayor Africa Luna-Carrasco	Aye
Council Member Mario Buchanan Jr.	Aye
Council Member Luis Cabrera	Aye
Council Member Jose Ponce	Aye
Council Member Matias Rosales	Aye
Council Member Gloria Torres	Aye

5. G. Discussion and possible action on any and all matters regarding the request to purchase a large volume of water meters and MXUs from Dana Kepner Company due to the shortage of supplies and the increased lead-times for products. (Jorge Perez, Billing & Collections Manager)

Mr. Jorge Perez, Billing & Collections Manager, indicated that this item is for the request of approval to purchase a large volume of water meters and MXUs which are the antennas that go along the water meters to be rented. The purchase will supply the city of water meters for a full year based on the usage of meters from previous years. During the past month of May, a notification from Xylem (Sensus) was received on the impact on current orders of water meters and all other products that they offer including MXUs (Antennas). Sensus is a worldwide manufacturer and uses distributors around the globe. The assigned distributor in the State of Arizona is Dana Kepner Company, who keep staff updated of the situation. He attempted to purchase water meters from different distributors from other states, but one kept being sent back to the local distributor in Arizona.

Dana Kepner Company just informed of lead times of up to 22 weeks on water meters coming from Sensus. Because of this reason, staff would like to place an order for water meters and MXUs that would last a year. Currently there are approximately 120 water meters in stock for new homes, which should last about three (3) months based on the average monthly installation rate. The total purchase costs \$177,026.65 and he asked that the Mayor and City Council waive the formal purchasing code as allowed in Section 3.05.10H of the City Code and to transfer funds from the Water CIP account in the amount of \$130,000.00 to the Minor Tools Equipment Supplies account and \$47,000.00 from the Salaries account.

MOTION: Council Member Gloria Torres/Council Member Luis Cabrera to approve the purchase of the water meters in the amount of \$177,026.65, to waive formal purchasing procedures and to transfer funds as presented. Motion passed unanimously.

The vote was as follows:

Mayor Gerardo Sanchez	Aye
Vice Mayor Africa Luna-Carrasco	Aye
Council Member Mario Buchanan Jr.	Aye
Council Member Luis Cabrera	Aye
Council Member Jose Ponce	Aye
Council Member Matias Rosales	Aye
Council Member Gloria Torres	Aye

5. H. Discussion and possible action on any and all matters regarding Subdivision Case No. 2021-0308F. A request by Edais Engineering, Inc, on behalf of the owner, for the final plat approval for Palencia Hills Subdivision. The property is located north of County 22nd Street and in alignment with Quintero Avenue. (Jose A. Guzman, Director of Planning and Zoning)

Mr. Jose Guzman, Director of Planning & Zoning, explained that this item is a request by Edais Engineering, Inc., on behalf of Salmos 127 1 LLC, future owner, for the approval of the final plat for Palencia Hills Subdivision. This subdivision consists of 10.51 acres to be divided into 18 lots and one (1) track for the retention. The minimum lot size is 20,000 square feet; and this subdivision is proposed to be a gated community. A Development Agreement was approved by the City Council on May 26th with Resolution No. 2180. This item was also presented to the Planning & Zoning Commission and they recommended approval. Staff is also recommending approval of the final plat with the condition that the applicant addresses comments on the letter dated June 3, 2021. The applicant already submitted revised plans and are under review by staff. Most of the conditions were part of the Planning & Zoning Commission comments. Mr. Guzman has not received comments from all the departments, he updated the letter with the comments received, therefore the letter of June 3rd will address all the comments pending.

Mayor Gerardo Sanchez asked if any of those comments interfere with the approval of the final plat.

Mr. Guzman replied no it will not interfere and added he sent the comments to the engineers and they agreed with all the comments.

MOTION: Council Member Matias Rosales/Council Member Mario Buchanan Jr. to approve Subdivision Case No. 2021-0308F with the condition that the applicant addresses comments on the letter dated June 3, 2021. Motion passed unanimously.

The vote was as follows:

Mayor Gerardo Sanchez	Aye
Vice Mayor Africa Luna-Carrasco	Aye
Council Member Mario Buchanan Jr.	Aye
Council Member Luis Cabrera	Aye
Council Member Jose Ponce	Aye
Council Member Matias Rosales	Aye
Council Member Gloria Torres	Aye

5. I. Discussion and possible action on any and all matters regarding Subdivision Case No. 2021-0181F. A request by Vega & Vega Engineering, PLC, on behalf of Sam Group Investment Co., owner, for the final plat approval for Belleza Del Desierto Phase 2 Subdivision. The property is located at the southeast corner of 20th Avenue and San Antonio Street. (Jose A. Guzman, Director of Planning and Zoning)

Mr. Jose Guzman, Director of Planning & Zoning, stated that this is request for the final plat approved for Belleza Del Desierto Phase 2 Subdivision. This subdivision is approximately 18.44 acres and will be divided into 87 lots and one (1) track for stormwater retention. The minimum lot size will be 6,000 square feet. This item was presented to the Planning & Zoning Commission and recommended approval. Staff recommends approval with the condition that the applicant addresses the review comment letter dated May 7th, 2021. The applicants submitted revised plans addressing the comments and are being reviewed by city staff. The applicant agreed to all the comments except for the requirement of a traffic study. This subdivision is part of the properties that will be contributing to the traffic signal at County 24th Street and Avenue E. As part of the condition, they have to pay \$260.00 per acre. They are claiming that if they are already contributing towards the signal light, why do they have to do a traffic study.

Council Member Matias Rosales asked if they had to do a traffic study for Belleza Del Desierto 1.

Mr. Eulogio Vera, Director of Public Works, indicated that a traffic study was submitted for Phase 1 of Belleza Del Desierto. Back then for Phase 1, staff considered that it was less than the 100 trips that is a recommendation for traffic studies. Phase 2 is a continuation of Phase 1, therefore it would exceed the 100 trips per peak hour any given day. He recommends them to demonstrate that a traffic study is not needed. Section 2-100 of the Standards provides the base guidelines for where a traffic study is required. If they establish that the access points are adequate and the traffic signal is enough, and nothing else is needed then a traffic study is not required but a traffic statement might be sufficient.

Mr. Vianey Vega, Vega and Vega Engineering, stated that they had the opportunity to respond to the comment letter of the conditions for the approval. The only condition they did not agree to is the requirement of the traffic study.

At the Planning & Zoning Commission meeting, the same item was discussed and staff was not requiring it, but they were discussing about the final decision to be made by the City Council. This project has access from County 24th Street and this street is developed to full width section road from Phase 1. In their project they are developing a full width midsection line that will have access to their development; there will be turning lanes from north and southbound. They are contributing to the traffic signal and do not feel that there is any other improvement that will require a traffic study nor prove that they have the proper access to the property on County 24th Street. The major requirement will be the traffic signal to be located at County 24th Street and Avenue E. There has also been several projects developed on this area that has not required a traffic study.

Mayor Gerardo Sanchez asked Mr. Vera how a traffic study is determined and how many of the subdivisions have not had a traffic study.

Mr. Vera responded that there is an option to do a traffic impact statement not necessarily a full traffic study, he agreed with some of the points that Mr. Vega mentioned. For example, Comite de Bienestar 11 is west of this development, if that was not to move forward, Belleza Del Desierto 1 and 2 would only have a single access to County 24th Street because there is nothing to the south or to the east. Mr. Vera believed having an impact statement or demonstrating what the routes are exiting or accessing this development would be an option and he can reference the Institute of Transportation of Engineers. An impact statement will be sufficient for staff for justifying what is needed or not needed. For the second question, Mr. Vega is the engineer doing developments for Comite de Bienestar so Mr. Vera is thinking that maybe Comite de Bienestar 10 and 11 did not require a traffic study. These are located at the intersection of County 24th Street and Avenue F and have two (2) access point to County 24th Street and they also widen and added turn lanes on County 24th Street and Avenue F. The only thing he sees that would require is a traffic signal and for the size of development which is less than 20 acres, so that was the reason a traffic study was not required.

Mayor Gerardo Sanchez asked if staff had a comment on the letter regarding the requirement of a traffic study or statement. Does staff agree that there is no need for a traffic study.

Mr. Guzman replied yes and that after Ordinance No. 392 approved in July 2019, staff has requested and added this condition to every new subdivision. Then it is routed to the Public Works Department to determine whether or not it is required.

Mr. Vera added that there is another development that the City Council approved recently, it is a small development, less than Palencia Hills. If the developer or engineer proposes something different and staff has accepted the traffic statement in lieu of the full traffic study.

Council Member Mario Buchanan Jr. stated that the city has been asking other developers for a traffic study and they have not had any problem complying with that. This is something needed for the community because that is the only way that the city can control the traffic there is in the City of San Luis. It is easy to say come and develop in this community but the city is the one that suffers the consequences with the traffic.

Ms. Elizabeth Carpenter, Developer, mentioned that when they developed Belleza Del Desierto 1, that is when they came to the agreement that they would pay towards the traffic light in lieu of a traffic study. This item was discussed at the Planning & Zoning Commission meeting last night and did not see the traffic study as a condition.

Mr. Guzman added that the items that Ms. Carpenter is referring to are for a minor amendment and rezoning not a subdivision process. Nevertheless if staff adds it as a condition on the final plat approval, the traffic study is required as set by Ordinance No. 392.

MOTION: Council Member Matias Rosales/Vice Mayor Africa Luna-Carrasco to approve Subdivision Case Number 2021-0181F with the condition that the applicant addresses review comments on the letter dated May 7, 2021 with the addition of the option of a traffic statement if approved by staff. Motion passed unanimously.

The vote was as follows:

Mayor Gerardo Sanchez	Aye
Vice Mayor Africa Luna-Carrasco	Aye
Council Member Mario Buchanan Jr.	Aye
Council Member Luis Cabrera	Aye
Council Member Jose Ponce	Aye
Council Member Matias Rosales	Aye
Council Member Gloria Torres	Aye

5. J. Discussion and possible action on any and all matters regarding Resolution No. 2181. A resolution of the Mayor and City Council of the City of San Luis, Arizona, creating a Street Lighting Improvement District and declaring its intention to purchase electricity, and maintain poles, luminaries, and underground conduit, together with a charge for the use of lighting facilities, for lighting public streets within the area described as Belleza Del Desierto Phase 2 Subdivision, San Luis, Arizona. (Jose A. Guzman, Director of Planning & Zoning)

Mr. Jose Guzman, Director of Planning & Zoning, stated that as a requirement of the subdivision regulations, a Street Lighting Improvement District is needed for any new subdivision. This resolution is the intention to create the Belleza Del Desierto Phase 2 Street Lighting Improvement District.

MOTION: Council Member Matias Rosales/Vice Mayor Africa Luna-Carrasco to approve and adopt Resolution No. 2181 as presented. Motion passed unanimously.

The vote was as follows:

Mayor Gerardo Sanchez	Aye
Vice Mayor Africa Luna-Carrasco	Aye
Council Member Mario Buchanan Jr.	Aye
Council Member Luis Cabrera	Aye
Council Member Jose Ponce	Aye
Council Member Matias Rosales	Aye
Council Member Gloria Torres	Aye

5. K. Discussion and possible action on any and all matters regarding Resolution No. 2182. A resolution of the Mayor and City Council of the City of San Luis, Arizona, declaring its intention to provide the Enhanced Municipal Services of operating, maintaining and improving certain retention basins serving the area described as Belleza del Desierto Phase 2 Subdivision, San Luis, Arizona. (Jose A. Guzman, Director of Planning & Zoning)

Mr. Jose Guzman, Director of Planning & Zoning, said this resolution is for the improvement district for the maintenance of the retention basins.

MOTION: Council Member Matias Rosales/Council Member Mario Buchanan Jr. to approve and adopt Resolution No. 2182 as presented. Motion passed unanimously.

The vote was as follows:

Mayor Gerardo Sanchez	Aye
Vice Mayor Africa Luna-Carrasco	Aye
Council Member Mario Buchanan Jr.	Aye
Council Member Luis Cabrera	Aye
Council Member Jose Ponce	Aye
Council Member Matias Rosales	Aye
Council Member Gloria Torres	Aye

5. L. Discussion and possible action on any and all matters regarding Resolution No. 2183. A resolution of the Mayor and City Council of the City of San Luis, Arizona declaring its intention of operating, maintaining, repairing and improving certain landscape improvements included within, near, and adjacent to the retention and detention basins and parking and parkways and related facilities together with appurtenant structures serving the area described as Belleza del Desierto Phase 2 Subdivision, San Luis, Arizona. (Jose A. Guzman, Director of Planning & Zoning)

Mr. Jose Guzman, Director of Planning & Zoning, stated that this resolution is for the maintenance of landscape improvements, after the approval of this resolution a second resolution is needed ordering the formation of the district.

MOTION: Vice Mayor Africa Luna-Carrasco/Council Member Luis Cabrera to approve and adopt Resolution No. 2183 as presented. Motion passed unanimously.

The vote was as follows:

Mayor Gerardo Sanchez	Aye
Vice Mayor Africa Luna-Carrasco	Aye
Council Member Mario Buchanan Jr.	Aye
Council Member Luis Cabrera	Aye
Council Member Jose Ponce	Aye
Council Member Matias Rosales	Aye
Council Member Gloria Torres	Aye

5. M. Discussion and possible action on any and all matters regarding Resolution No. 2184. A resolution of the Mayor and City Council of the City of San Luis, Arizona, authorizing and directing the city engineer to order the purchase of electricity and to order the maintenance of poles, luminaries, and underground conduit incident to the installation of street lights for lighting public streets serving the area described as Belleza Del Desierto Phase 2 Subdivision, San Luis, Arizona. (Jose A. Guzman, Director of Planning & Zoning)

Mr. Jose Guzman, Director of Planning & Zoning, indicated that once a resolution creating an improvement district is approved, a second resolution authorizing work and approving the implementation of the district is required, this resolution is for the Street Lighting Improvement District.

MOTION: Vice Mayor Africa Luna-Carrasco/Council Member Mario Buchanan Jr. to approve and adopt Resolution No. 2184 as presented. Motion passed unanimously.

The vote was as follows:

Mayor Gerardo Sanchez	Aye
Vice Mayor Africa Luna-Carrasco	Aye
Council Member Mario Buchanan Jr.	Aye
Council Member Luis Cabrera	Aye
Council Member Jose Ponce	Aye
Council Member Matias Rosales	Aye
Council Member Gloria Torres	Aye

5. N. Discussion and possible action on any and all matters regarding Resolution No. 2185. A resolution of the Mayor and City Council of the City of San Luis, Arizona, authorizing and directing the city engineer to order the operation and maintenance of certain retention basins for the area described as Belleza Del Desierto Phase 2 Subdivision, San Luis, Arizona. (Jose A. Guzman, Director of Planning & Zoning)

Mr. Jose Guzman, Director of Planning & Zoning, said that this resolution is for the implementation of the Enhanced Municipal Improvement District.

MOTION: Council Member Gloria Torres/Council Member Luis Cabrera to approve and adopt Resolution No. 2185 as presented. Motion passed unanimously.

The vote was as follows:

Mayor Gerardo Sanchez	Aye
Vice Mayor Africa Luna-Carrasco	Aye
Council Member Mario Buchanan Jr.	Aye
Council Member Luis Cabrera	Aye
Council Member Jose Ponce	Aye
Council Member Matias Rosales	Aye
Council Member Gloria Torres	Aye

5. O. Discussion and possible action on any and all matters regarding Resolution No. 2186. A resolution of the Mayor and City Council of the City of San Luis, Arizona, authorizing and ordering the operation, maintenance, and repair of certain landscape improvements included within, near, and adjacent to the retention and detention basins, parking, parkways, and related facilities together with appurtenant structures serving the area described as Belleza Del Desierto Phase 2 Subdivision, San Luis, Arizona. (Jose A. Guzman, Director of Planning & Zoning)

Mr. Jose Guzman, Director of Planning & Zoning, explained that this resolution is to implement the Landscape Improvement District.

MOTION: Council Member Luis Cabrera/Council Member Jose Ponce to approve and adopt Resolution No. 2186 as presented. Motion passed unanimously.

The vote was as follows:

Mayor Gerardo Sanchez	Aye
Vice Mayor Africa Luna-Carrasco	Aye
Council Member Mario Buchanan Jr.	Aye
Council Member Luis Cabrera	Aye
Council Member Jose Ponce	Aye
Council Member Matias Rosales	Aye
Council Member Gloria Torres	Aye

5. P. Public hearing followed by discussion and possible action on any and all matters regarding Text Amendment Case No. 2021-0293 and Ordinance No. 417. An ordinance of the Mayor and City Council of San Luis, Arizona by amending Chapter 18 Zoning Regulations Section 18.30.020(E)(7) and 18.30.030(E)(6) of the San Luis City Code to change the requirements for covered parking on Multiple Residential Zoning Districts. (Jose A. Guzman, Director of Planning & Zoning)

A. Open public hearing

MOTION: Vice Mayor Africa Luna-Carrasco/Council Member Luis Cabrera to open the public hearing. Motion passed unanimously.

The vote was as follows:

Mayor Gerardo Sanchez	Aye
Vice Mayor Africa Luna-Carrasco	Aye
Council Member Mario Buchanan Jr.	Aye
Council Member Luis Cabrera	Aye
Council Member Jose Ponce	Aye
Council Member Matias Rosales	Aye
Council Member Gloria Torres	Aye

1. Staff presentation

Mr. Jose Guzman, Director of Planning & Zoning, stated that this item was presented to the Mayor and City Council during a Work Session in April 2021 and the current regulations required that all parking spaces for multiple residence buildings have to be covered. Staff considers this requirement too restrictive and is proposing the amendment. The amendment is not a reduction of the required parking spaces but a reduction in the required cover parking spaces. This item was also presented to the Planning and Zoning Commission and they recommend approval of the text amendment. Staff recommends the approval as well for Ordinance No. 417, the change in the regulations will help staff continue being develop friendly.

2. Call to the Public on this item

Ms. Sonia Cornelio, City Clerk, indicated that the City Clerk's Office did not receive any comments or speaker request forms regarding this item.

B. Close public hearing

MOTION: Council Member Mario Buchanan Jr./Council Member Jose Ponce to close the public hearing. Motion passed unanimously.

The vote was as follows:

Mayor Gerardo Sanchez	Aye
Vice Mayor Africa Luna-Carrasco	Aye
Council Member Mario Buchanan Jr.	Aye
Council Member Luis Cabrera	Aye
Council Member Jose Ponce	Aye
Council Member Matias Rosales	Aye
Council Member Gloria Torres	Aye

C. Action on Reading of Ordinance No. 417 by title only.

MOTION: Council Member Luis Cabrera/Council Member Mario Buchanan Jr. to approve reading of Ordinance No. 417 by title only. Motion passed unanimously.

The vote was as follows:

Mayor Gerardo Sanchez	Aye
Vice Mayor Africa Luna-Carrasco	Aye
Council Member Mario Buchanan Jr.	Aye
Council Member Luis Cabrera	Aye
Council Member Jose Ponce	Aye
Council Member Matias Rosales	Aye
Council Member Gloria Torres	Aye

Ms. Sonia Cornelio, City Clerk, read Ordinance No. 417 by title only.

D. Action on Ordinance No. 417

MOTION: Council Member Luis Cabrera/Council Member Jose Ponce to approve and adopt Ordinance No. 417. Motion passed unanimously.

The vote was as follows:

Mayor Gerardo Sanchez	Aye
Vice Mayor Africa Luna-Carrasco	Aye
Council Member Mario Buchanan Jr.	Aye
Council Member Luis Cabrera	Aye
Council Member Jose Ponce	Aye
Council Member Matias Rosales	Aye
Council Member Gloria Torres	Aye

6. SUMMARY OF CURRENT EVENTS

Mayor Gerardo Sanchez reported that he has held meetings with different agencies that are dealing with the Port of Entry and trying to get the funding. It appears that the cost of the port has increased approximately 20%, the city is working with the congressional delegation and the multiple agencies in Mexico for the construction of the Port of Entry.

Vice Mayor Africa Luna-Carrasco reported she attended the Library Board of Trustees meeting, they are finalizing their budget and they are including the the air conditioning units for the San Luis Branch. They also received a grant for a traveling holocaust museum, they were one of the few libraries in the country to be awarded that grant. They have fully re-opened and are back with all the events and programs in addition they have reported that the San Luis Branch had the highest number for the program offered to adults for english classes.

7. CALL TO THE PUBLIC

Mr. Gary Snyder, PO Box 2191, San Luis, AZ, stated that he had a question for Ms. Sonia Cornelio, City Clerk or the City Attorney. He wanted to find out what would deem a City Council Member or possibly a Mayor to lose their seat. What kind of criminal act would take them off or render their position.

Ms. Kay Macuil, City Attorney, responded that she would have to study that question as this is the time for public comment not for questions.

Mr. Snyder added that he is challenging the integrity of the Oath of Office from an elected official and he wants the City Council and the Mayor to check on and find out at a later date and indicated that he had a public audio that he played. The audio played is in spanish and translated as follows:

“...and the Attorney General, one is not used to those things, two sheriffs arrived and then the attorney and that there was something against me and wanted to take my fingerprints and I asked but why, two (2) weeks ago my fingerprints were taken at the police department for the church and I told them that they are the law and they can get them from anywhere. But he said they are specific and I said I will go right now and he said no, if you refuse we can take you with an order from the judge, there is a complaint against you and we want to fingerprint you, so then I said how far can we get...”

Mr. Snyder mentioned that this is a public audio he obtained from a public records request at the police department, actually Lieutenant Marco Santana was the receiving officer, so the question he has is the integrity of oath everyone has taken as the law. He added that obviously right now, there is nothing pending but for the Attorney General and a sheriff to come down and check someone's fingerprints, he recommended as the Mayor, Vice Mayor, City Council and City Attorney to keep an eye on because San Luis is already known with the issue from of the persons from San Luis has endicments. He is not saying she is guilty or not, obviously until the court of law, but there is already a lot of negativity for San Luis and to bring an opportunity, the possibility of a further action, he wants the city to be ready for it.

Mayor Gerardo Sanchez asked Ms. Macuil to make sure there is a legal response in writing.

8. ADJOURNMENT

MOTION: Council Member Luis Cabrera/Council Member Jose Ponce to adjourn the Regular Council meeting at approximately 8:48 p.m. Motion passed unanimously.

The vote was as follows:

Mayor Gerardo Sanchez	Aye
Vice Mayor Africa Luna-Carrasco	Aye
Council Member Mario Buchanan Jr.	Aye
Council Member Luis Cabrera	Aye
Council Member Jose Ponce	Aye
Council Member Matias Rosales	Aye
Council Member Gloria Torres	Aye

APPROVED:

Gerardo Sanchez, Mayor

ATTEST:

Sonia Cornelio, City Clerk

CERTIFICATION

I hereby certify that the foregoing minutes are a true and correct copy of the minutes of the Regular City Council meeting of the City Council of the City of San Luis, Arizona, held on June 9, 2021. I further certify that the meeting was duly called and held and that a quorum was present.

Sonia Cornelio, City Clerk

MINUTES
Regular Council Meeting
San Luis City Council
San Luis Council Chambers
1090 E. Union Street
June 23, 2021
7:00 p.m.

1. CALL TO ORDER/ROLL CALL

Mayor Gerardo Sanchez called the Regular City Council meeting to order at approximately 7:01 p.m.

Mayor, City Council, and some members of staff participated remotely.

PRESENT: Mayor Gerardo Sanchez
Vice Mayor Africa Luna-Carrasco
Council Member Mario Buchanan Jr.
Council Member Luis Cabrera
Council Member Jose Ponce
Council Member Matias Rosales
Council Member Gloria Torres

OTHERS PRESENT: Tadeo A. De La Hoya, City Administrator
Sonia Cornelio, City Clerk
Kay Marion Macuil, City Attorney
Angel Ramirez, Fire Chief
Axel Chaira, I.T. Department
Eulogio Vera, Director of Public Works
Glenn Gimbut, Assistant City Attorney
Jenny Torres, Economic Development Manager
Jonathan Dumadag, I.T. Department
Jorge Perez, Billing & Collections Manager
Jose Luis Cisneros, Executive Assistant
Mary French-Jones, Grant Writer
Miguel Ramirez, Acting Assistant Director of Finance
Monica Castro, Director of Finance
Richard Jessup, Chief of Police
Rosalva Leon, Human Resources Coordinator
Roula Encinas, Acting Assistant Director of Finance
David Nuñez, Arizona State University Intern
Guadalupe Bustamante, Arizona State University Intern
Adelaida Buchanan, Resident
Buna George, Director to Greater Yuma Port Authority
Cesar Neyoy, Reporter
Christian Cuevas, Translator
Gary Snyder, Resident
Guillermina Fuentes, Resident

Paul Brierly, Executive Director to University of Arizona
Yuma Center of Excellence for Desert Agriculture

2. PLEDGE OF ALLEGIANCE

Council Member Jose Ponce led the Pledge of Allegiance.

3. INVOCATION

Mr. Richard Jessup, Chief of Police, led the invocation.

4. PRESENTATIONS

4. A. Presentation on any and all matters regarding Greater Yuma Port Authority's activities. (Buna George, Executive Director to Greater Yuma Port Authority)

Ms. Buna George, Executive Director to Greater Yuma Port Authority (GYPA), briefly presented a PowerPoint presentation providing their summary of events. She spoke about the Member Entities, GYPA's Timeline, Travel Restrictions, Collaborative Events, Magrino Industrial Park and their action items. Ms. George thanked the City of San Luis for the partnership. The presentation is filed with the City Clerk's Office with the complete agenda packet.

4. B. Presentation on any and all matters regarding the COVID-19 Sewage Testing Early Warning Program. (Paul E. Brierley, Executive Director to The University of Arizona Yuma Center of Excellence for Desert Agriculture)

Mr. Paul E. Brierley, Executive Director to The University of Arizona Yuma Center of Excellence for Desert Agriculture (YCEDA), stated that YCEDA was asked by one of the donors if there was something they could do to help Yuma County get back to work safely, specifically with the vegetable season coming up. They decided in the process utilized in Tucson at the University of Arizona to analyze wastewater and look for the virus that causes COVID-19. This can be detected a week before someone who was infected would have symptoms. Mr. Brierley provided a presentation on how the Waste-Based Epidemiology (WBE) works and its possible uses. He hopes to get a sample from the San Luis Rio Colorado, Sonora.

Mayor Gerardo Sanchez thanked Mr. Brierley for the presentation and added that this tool gave an opportunity to the residents of the City of San Luis to be inform of the virus.

CONSENT AGENDA

5. A. MINUTES OF

- Work Session held May 19, 2021**
- Regular Council meeting held May 26, 2021**

5. B. DISBURSEMENTS FROM JUNE 2, 2021 TO JUNE 14, 2021

Total Disbursements \$1,650,223.05

(One Million, Six Hundred Fifty Thousand, Two Hundred, Twenty - Three Dollars and Five Cents)

MOTION: Council Member Gloria Torres/Council Member Mario Buchanan Jr. to approve the Consent Agenda as presented. Motion passed unanimously.

The vote was as follows:

Mayor Gerardo Sanchez	Aye
Vice Mayor Africa Luna-Carrasco	Aye
Council Member Mario Buchanan Jr.	Aye
Council Member Luis Cabrera	Aye
Council Member Jose Ponce	Aye
Council Member Matias Rosales	Aye
Council Member Gloria Torres	Aye

6. DISCUSSION AND POSSIBLE ACTION ITEMS:

6. A. Discussion and possible action on any and all matters regarding an informational update on the Mesa Street Improvements project. (Jenny Torres, Economic Development Manager)

Ms. Jenny Torres, Economic Development Manager, said that a work session was held in May 2020 for a public hearing at which the City Council selected Mesa Street as one of the priority projects to be submitted to the Arizona Department of Housing for Community Development Block Grant. In August 2020, staff began the design of the project and titled it Mesa Street Improvements Phasing Project. Phase 1 includes improvement to the roads, sidewalks, curb and gutter, ADA ramps, storm draining and retaining wall. Phase 2 includes the tie-ins for C and D Streets road improvements, curb and gutter, sidewalk, pedestrian concrete steps with safety rails and private land acquisition.

Mr. Eulogio Vera, Director of Public Works, explained a graphic as shown on the PowerPoint presentation, attached to the complete Agenda Packet filed at the City Clerk's Office. He spoke about what staff thinks is the best layout and circulation for Phase 1. There was some dialogue regarding the drainage requirements/removal as well as the easements or acquisition of land on the east and west property corners to fit the sidewalk ramps and one-way/two-way width roads.

Ms. Torres mentioned that staff is negotiating with five (5) owners for the land acquisition. The staff is requesting an easement, which is an authorization for the city to perform improvement but they will still own the land. This is being done as part of the application to obtain site control and not be disqualified. But staff will go back to the City Council and recommend the purchase of the land. The acquisition of the land will improve the area and increase the value of their property.

She added that the engineer's cost estimate for Phase 1 is \$908,565.00; and Phase 2 is \$211,856.00. The final cost estimate for the private land acquisition is unknown, as it is still going through the appraisal process.

The city is applying for \$626,215.00, the city has allocated \$486,320.00 from the General Fund and the HURF account for Phase 1 and 2 but not for the land acquisition. The application is due next week and the funds/alternative award of funds will be awarded mid August. Site control of private land is for January 2022, begin construction in March 2022 and completion in September 2022. These dates are estimates and are based on the site control. Staff encountered challenges and received good news from Yuma County Water Users Association and they are willing to work with staff in regards to the drainage system. An application was submitted to Bureau of Land Management to acquire specific parts of land in downtown that would focus in parks. One of the items that residents addressed is the commercial truck traffic and access obstruction on C Street. What residents are complaining about is the traffic heading southbound and the deliveries happening as those trucks block any resident from having access to their property. Once the improvements are constructed, this will no longer be able to do that as enforcement will be stronger.

Mayor Gerardo Sanchez added that this project has been talked about for approximately six (6) years. He thanked staff for the update and looks forward for the opportunity for these improvements.

6. B. Discussion and possible action on any and all matters regarding an increase of the purchase price of an ambulance above the price City Council approved in September of 2020. (Angel Ramirez, Fire Chief)

Mr. Angel Ramirez, Fire Chief, stated that this item was presented to the City Council in September 2020. After the purchase price, during the build staff learned some material during the COVID-19 phase and added a special UV light to the ambulance. This addition increased the price in the amount of \$701.00. He requested that the Mayor and City Council ratify purchase order #2021-696 to Republic EVS in the amount of \$701.00

MOTION: Council Member Jose Ponce/Vice Mayor Africa Luna-Carrasco to ratify the \$701.00 increased price to purchase the ambulance as presented. Motion passed unanimously.

The vote was as follows:

Mayor Gerardo Sanchez	Aye
Vice Mayor Africa Luna-Carrasco	Aye
Council Member Mario Buchanan Jr.	Aye
Council Member Luis Cabrera	Aye
Council Member Jose Ponce	Aye
Council Member Matias Rosales	Aye
Council Member Gloria Torres	Aye

6. C. Public hearing followed by discussion and possible action on any and all matters regarding Resolution No. 2187. A resolution of the Mayor and City Council of the City of San Luis, Arizona, adopting the budget for Fiscal Year 2021-2022. (Monica Castro, Director of Finance)

A. Open public hearing

MOTION: Vice Mayor Africa Luna-Carrasco/Council Member Jose Ponce to open the public hearing. Motion passed unanimously.

The vote was as follows:

Mayor Gerardo Sanchez	Aye
Vice Mayor Africa Luna-Carrasco	Aye
Council Member Mario Buchanan Jr.	Aye
Council Member Luis Cabrera	Aye
Council Member Jose Ponce	Aye
Council Member Matias Rosales	Aye
Council Member Gloria Torres	Aye

1. Staff Presentation

Ms. Monica Castro, Director of Finance, explained that two (2) weeks ago, staff presented the tentative budget to the Mayor and City Council for approval, since then, the tentative budget was published in the local newspaper inviting the public to comment. After the tentative budget was approved, it was brought to staff's attention the need to add an additional position to the budget. It was the Code Enforcement position to ensure compliance for the Public Works and business activities. In order to accommodate this request, staff removed an assistant position for Public Works and reallocated some expenses. This change did not increase the budget, nor changed the positions considered in the budget; by state statute, the budget cannot be increased after it is presented and staff can only reallocate resources to make sure that the needs for the city are met. Staff recommends approval of the final budget for Fiscal Year 2022 of \$94,976,387.00.

Council Member Matias Rosales commented that in reading the newspaper it read the city was in a deficit and asked if this is incorrect.

Ms. Castro stated that the city is not in deficit and the budget is balanced. In fact, it is required by state statute, that City Council cannot adopt a budget that is not balanced, but in order to balance the budget, it is not only taking the revenues and expenditures. One has to make sure that the recurring revenues match recurring expenditures. Also, that there be carrying balances from prior years, therefore staff has to make sure that those match with one-time expenditures because those are not going to occur again, specially with COVID-19 that the city did not spend as much since travel was suspended and some projects were delayed. The city was able to accumulate a positive carryover that will be able used next year for projects.

She indicated on the spreadsheet displayed during the City Council meeting, that the balance net position shows \$28 million which include the positive balances. The bottom line demonstrates the resources available in the amount of \$142 million which is a positive carryover versus the city's projected expenditures of \$89 million that does not include the transfers out.

Council Member Luis Cabrera asked when will the projects happen and if an estimated timeline could be provided or presented to the City Council within the next two (2) upcoming work sessions.

Mayor Gerardo Sanchez added that he agrees but the city is dynamic and unfortunately with the pandemic staff is not sure. Staff can say the projects are going to be done in a particular time but if they are not, what happens then. There is a list of the projects and the presentations from the different departments, it is very difficult to commit as there might be another delay if the pandemic occurs once again as COVID-19 is not over yet. He stressed that the city is not in a deficit and projects will get done; it is important that the community knows that project need to get done.

2. Call to the public on this item

There were no comments from the public on this item.

B. Close public hearing

MOTION: Council Member Matias Rosales/Council Member Jose Ponce to close the public hearing. Motion passed unanimously.

The vote was as follows:

Mayor Gerardo Sanchez	Aye
Vice Mayor Africa Luna-Carrasco	Aye
Council Member Mario Buchanan Jr.	Aye
Council Member Luis Cabrera	Aye
Council Member Jose Ponce	Aye
Council Member Matias Rosales	Aye
Council Member Gloria Torres	Aye

C. Action on Resolution No. 2187

MOTION: Council member Mario Buchanan Jr./Council Member Luis Cabrera to approve and adopt Resolution No. 2187. Motion passed unanimously.

The vote was as follows:

Mayor Gerardo Sanchez	Aye
Vice Mayor Africa Luna-Carrasco	Aye
Council Member Mario Buchanan Jr.	Aye
Council Member Luis Cabrera	Aye
Council Member Jose Ponce	Aye
Council Member Matias Rosales	Aye
Council Member Gloria Torres	Aye

6. D. Discussion and possible action on any and all matters regarding Order No. 2021-6. An order of the Mayor and City Council of the City of San Luis, Arizona declaring the Employee Benefits Plans a public record; approving the Employee Benefits Plans for the Fiscal Year 2021-2022 for administration by the San Luis Employee Benefits Trust; providing for repeal of conflicting actions of City Council; providing for severability; and establishing an effective date for the plans. (Edgardo Carbajal, Acting Director of Human Resources)

Ms. Rosalva Leon, Human Resources Coordinator, mentioned that staff recommends approval of the Employee Benefits Plan for Fiscal Year 2021-2022. The Employee Benefits Trust approved the Employee Benefits Plan at their meeting of April 16, 2021. The final budget amount allocated for benefits plans is \$3,514,079.00 and it is to take effect July 1, 2021.

Mayor Gerardo Sanchez stated that as Chairman of the Board, the employees' premiums are not going to be increased, the city continues to offer one of the best medical plans for employees thanks to the broker. The number of claims have been higher but has managed to keep costs down in regards to the employee's premiums.

MOTION: Council Member Jose Ponce/Council Member Luis Cabrera to approve Order No. 2021-6. Motion passed unanimously.

The vote was as follows:

Mayor Gerardo Sanchez	Aye
Vice Mayor Africa Luna-Carrasco	Aye
Council Member Mario Buchanan Jr.	Aye
Council Member Luis Cabrera	Aye
Council Member Jose Ponce	Aye
Council Member Matias Rosales	Aye
Council Member Gloria Torres	Aye

7. SUMMARY OF CURRENT EVENTS

Mayor Gerardo Sanchez reported that the City of San Luis continues its internship programs, currently the city has nine (9) interns from Arizona State University (ASU).

This programs helps the interns gain experience in the various departments of how government functions. He also mentioned that the funds for the Port of Entry that is needed, supposedly it was \$90 million, now it appears that it will be over \$100 million. There is support from the Arizona Congressional Delegation, U.S. Customs and Border Protection, General Services Administration and the federal government. He also reported that the Mexican authorities are working attentively regarding Avenida Morelos and Archibald Street in fixing the problem that is created in the evenings, NADBANK has responded regarding the funding of the studies but should know within two (2) weeks. He met last week with the different organizations about the situations at the Ports of Entry and borders. The city is facilitating with the Mexican Consulate and Ms. Amanda Aguirre, vaccinations of the Johnson & Johnson at the Port of Entry 2. If this goes well, they will continue to provide vaccinations to the counterparts in Mexico, specially those in the industry.

Council Member Matias Rosales reported he was invited by ADOT to attend the back to live training sessions for the cross-border truck drivers training. In attending that meeting Officer Carbajal found the garage gate opener for the gate ADOT has at the Magrino Park. He also attend the Yuma County Planning & Zoning meeting and added that tomorrow he will attend the Greater Yuma Port Authority meeting in the morning and the Yuma Metropolitan Planning Organization in the afternoon. He also informed that the Nationals Bike Ride will take place in October 2021. He also saw city employees participating in the kickball program last night and it felt great to see them back in the park having fun.

Council Member Luis Cabrera reported that he joined the 38th Annual NALEO Conference this morning. He thanked the Department Heads for the monthly reports submitted and Parks & Recreation for the different things going on for the citizens, kids and youth of the community.

Council Member Jose Ponce reported that he continues to assist Mr. Manuel Castro, Gethsemani Food Ministry, in the distribution of food boxes to members of the community. He has been attending the Campesinos Sin Fronteras events and is very active at the Senior Center activities.

8. CALL TO THE PUBLIC

Mr. Gary Snyder, PO Box 2191, San Luis, Arizona, congratulated the Mayor and City Council for the 4th of July, adding that it is great to have it open for the community. He stated that he was going to wait a few minutes or pass because he is waiting on a legal document to go by and has not received it yet.

Ms. Guillermina Fuentes, 1630 N. 9th Avenue, San Luis, Arizona, congratulated the Mayor and City Council for the work they are doing for this community. She added that it does not matter how hard the City Council works, they will be criticized but do not feel bad because there are evil people outside who will do it. At least the City Council gets compensated and as School Board Members they do not get paid to receive all the garbage.

She recommended the City Council to not get frustrated as people chose them to represent them because they believe in them and it does not matter what two (2), three (3) or four (4) toxic people say about the City Council. She asked the Mayor and City Council to continue working hard so that they do not let citizens down.

9. EXECUTIVE SESSION

Vote to hold an Executive Session pursuant to A.R.S. § 38-431.03(A) (3)

Discussion and possible action to hold an Executive Session pursuant to A.R.S. § 38-431.03(A) (3) for legal advice with the city's attorneys regarding County 24th Street and Avenue E. (Kay Marion Macuil, City Attorney and Assistant City Attorney Glenn Gimbut)

MOTION: Council Member Matias Rosales/Council Member Mario Buchanan Jr. to go into Executive Session at approximately 8:26 p.m. Motion passed unanimously.

The vote was as follows:

Mayor Gerardo Sanchez	Aye
Vice Mayor Africa Luna-Carrasco	Aye
Council Member Mario Buchanan Jr.	Aye
Council Member Luis Cabrera	Aye
Council Member Jose Ponce	Aye
Council Member Matias Rosales	Aye
Council Member Gloria Torres	Aye

10. MOTION TO GO BACK INTO REGULAR SESSION

MOTION: Vice Mayor Africa Luna-Carrasco/Council Member Jose Ponce to go back into Regular Session at approximately 8:44 p.m. Motion passed unanimously.

The vote was as follows:

Mayor Gerardo Sanchez	Aye
Vice Mayor Africa Luna-Carrasco	Aye
Council Member Mario Buchanan Jr.	Aye
Council Member Luis Cabrera	Aye
Council Member Jose Ponce	Aye
Council Member Matias Rosales	Aye
Council Member Gloria Torres	Aye

11. ADJOURNMENT

MOTION: Vice Mayor Africa Luna-Carrasco/Council Member Jose Ponce to adjourn the Regular Council meeting at approximately 8:45 p.m. Motion passed unanimously.

The vote was as follows:

Mayor Gerardo Sanchez	Aye
Vice Mayor Africa Luna-Carrasco	Aye
Council Member Mario Buchanan Jr.	Aye
Council Member Luis Cabrera	Aye
Council Member Jose Ponce	Aye
Council Member Matias Rosales	Aye
Council Member Gloria Torres	Aye

APPROVED:

Gerardo Sanchez, Mayor

ATTEST:

Sonia Cornelio, City Clerk

CERTIFICATION

I hereby certify that the foregoing minutes are a true and correct copy of the minutes of the Regular City Council meeting of the City Council of the City of San Luis, Arizona, held on June 23, 2021. I further certify that the meeting was duly called and held and that a quorum was present.

Sonia Cornelio, City Clerk



AGENDA ITEM REVIEW FORM

Regular City Council Meeting

4. B.

Meeting Date: 07/14/2021

Summary

DISBURSEMENTS FROM JUNE 15, 2021 TO JUNE 28, 2021

Total Disbursements \$992,577.36

(Nine Hundred Ninety-Two Thousand, Five Hundred, Seventy-Seven Dollars and Thirty-Six Cents)

Attachments

Disbursements



City of San Luis

Finance Department

COUNCIL MEETING JUL 14, 2021 Disbursement Report from 06/15/2021 TO 06/28/2021

<u>Bank Accounts</u>	<u>Check Date</u>	<u>Amount</u>	<u>Schedule</u>
Accounts Payable Check Account	6/17/2021	\$ 373,114.91	Schedule A
Payroll Check Account	6/08/2021	\$ 56,002.24	Schedule B
Payroll Check Account	6/09/2021	\$ 329,561.67	Schedule C
Accounts Payable Check Account	6/10/2021	\$ 233,898.54	Schedule D

Total Disbursements: \$ 992,577.36

Please contact Ms. Monica Castro prior to the meeting if additional information is needed.

Prepared by David A. Espitia: David Espitia

Verified by Director of Finance: Monica Castro

For Council approval on: _____

Mayor: _____

Council: _____

RECEIVED

2021 JUN 28 P 5 27

CITY OF SAN LUIS
OFFICE OF THE CITY CLERK

Payment Register

From Payment Date: 6/14/2021 - To Payment Date: 6/17/2021

Number	Date	Status	Void Reason	Reconciled/ Voided Date	Source	Payee Name	Transaction Amount	Reconciled Amount	Difference
1BYPAYABLE - 1st BY Accounts Payable									
<u>Check</u>									
98529	06/14/2021	Open			Accounts Payable	AZ ASSOCIATION OF COUNTIES	\$185.00		
98530	06/14/2021	Open			Accounts Payable	VILLA, CARLOS ALBERTO	\$255.00		
98531	06/17/2021	Open			Accounts Payable	LEON, AURORA	\$169.36		
98532	06/17/2021	Open			Accounts Payable	RODRIGUEZ, ALEJANDRO	\$18.70		
98533	06/17/2021	Open			Accounts Payable	ALVAREZ, MIGUEL	\$327.00		
98534	06/17/2021	Open			Accounts Payable	ECHAVARRIA, NOHEMY	\$192.00		
98535	06/17/2021	Open			Accounts Payable	ENTERPRISE FM TRUST	\$755.68		
98536	06/17/2021	Open			Accounts Payable	FRANCO, AIDA	\$30.00		
98537	06/17/2021	Open			Accounts Payable	GAITAN, CESAR	\$327.00		
98538	06/17/2021	Open			Accounts Payable	GUEVARA, ALAN	\$192.00		
98539	06/17/2021	Open			Accounts Payable	LARA, PAULINO	\$327.00		
98540	06/17/2021	Open			Accounts Payable	MILLER, DAMIAN	\$192.00		
98541	06/17/2021	Open			Accounts Payable	RAMIREZ, ALEJANDRO	\$192.00		
98542	06/17/2021	Open			Accounts Payable	RAMIREZ, IRENE	\$60.00		
98543	06/17/2021	Open			Accounts Payable	REYNOSO, NIGEL	\$192.00		
98544	06/17/2021	Open			Accounts Payable	SOSA, DOMINGO	\$51.97		
98545	06/17/2021	Open			Accounts Payable	VALENCIA, LINO	\$327.00		
98546	06/17/2021	Open			Accounts Payable	VALENZUELA, FABIOLA	\$100.00		
98547	06/17/2021	Open			Accounts Payable	VILLEGAS, FRANCISCO	\$60.00		
98548	06/17/2021	Open			Accounts Payable	AHERN RENTALS, INC.	\$177.25		
98549	06/17/2021	Open			Accounts Payable	AIRGAS-WEST	\$280.15		
98550	06/17/2021	Open			Accounts Payable	ALSCO, INC	\$2,042.35		
98551	06/17/2021	Open			Accounts Payable	AMARO ARMENTA, ALAN	\$62.00		
98552	06/17/2021	Open			Accounts Payable	AMAZON.COM SALES, INC.	\$106.64		
98553	06/17/2021	Open			Accounts Payable	APS/CLAIM #414-1352-AH	\$50.00		
98554	06/17/2021	Open			Accounts Payable	ARIZONA CITY/COUNTY MANAGEMENT	\$245.56		
98555	06/17/2021	Open			Accounts Payable	ARIZONA EMERGENCY PRODUCTS, INC.	\$39,308.16		
98556	06/17/2021	Open			Accounts Payable	ARIZONA MEDICAL WASTE	\$74.88		
98557	06/17/2021	Open			Accounts Payable	ARIZONA MEXICO COMMISSION	\$1,500.00		
98558	06/17/2021	Open			Accounts Payable	ARIZONA STATE LAND DEPARTMENT	\$708.89		
98559	06/17/2021	Open			Accounts Payable	ARIZONA STATE TREASURER	\$56,924.77		
98560	06/17/2021	Open			Accounts Payable	ARIZONA WESTERN COLLEGE	\$277.06		
98561	06/17/2021	Open			Accounts Payable	AUTOZONE STORES, INC	\$679.33		
98562	06/17/2021	Open			Accounts Payable	B&H PHOTO & ELECTRONICS CORP.	\$543.10		
98563	06/17/2021	Open			Accounts Payable	BILL ALEXANDER FORD	\$37,502.11		
98564	06/17/2021	Open			Accounts Payable	BILL ALEXANDER FORD	\$37,502.11		
98565	06/17/2021	Open			Accounts Payable	BINGHAM EQUIPMENT CO	\$2,401.02		
98566	06/17/2021	Open			Accounts Payable	BORDER PRECAST INC.	\$410.00		
98567	06/17/2021	Open			Accounts Payable	BOUND TREE MEDICAL, LLC.	\$3,724.01		
98568	06/17/2021	Open			Accounts Payable	CAMARENA, AXEL	\$11.00		
98569	06/17/2021	Open			Accounts Payable	CDWG	\$50,142.14		
98570	06/17/2021	Open			Accounts Payable	CORDOVA LAW, PLC	\$3,800.00		
98571	06/17/2021	Open			Accounts Payable	DANA KEPNER COMPANY LLC	\$5,723.06		
98572	06/17/2021	Open			Accounts Payable	DESERT VALLEY SERVICES, INC	\$65.91		

Payment Register

From Payment Date: 6/14/2021 - To Payment Date: 6/17/2021

Number	Date	Status	Void Reason	Reconciled/ Voided Date	Source	Payee Name	Transaction Amount	Reconciled Amount	Difference
98573	06/17/2021	Open			Accounts Payable	DESERT WATER STORE INC	\$199.58		
98574	06/17/2021	Open			Accounts Payable	ESPARZA, ALAN	\$1,000.00		
98575	06/17/2021	Open			Accounts Payable	ESTRADA, LETICIA	\$41.84		
98576	06/17/2021	Open			Accounts Payable	FRESH TERRA SERVICES LLC	\$1,658.00		
98577	06/17/2021	Open			Accounts Payable	GILA ELECTRONIC	\$6,815.86		
98578	06/17/2021	Open			Accounts Payable	HANSBERGER REGRIGERATION & ELECTRIC CO	\$748.00		
98579	06/17/2021	Open			Accounts Payable	HERNANDEZ LOPEZ, SOFIA I	\$118.00		
98580	06/17/2021	Open			Accounts Payable	HUGHES FIRE EQUIPMENT, INC.	\$239.58		
98581	06/17/2021	Open			Accounts Payable	KS STATE BANK	\$236.59		
98582	06/17/2021	Open			Accounts Payable	LEON MEJIA, JOSE MARTIN	\$90.94		
98583	06/17/2021	Open			Accounts Payable	LEON, CLAUDIA LUCRECIA	\$103.00		
98584	06/17/2021	Open			Accounts Payable	MCNEECE BROS. OIL COMPANY, INC	\$33,029.19		
98585	06/17/2021	Open			Accounts Payable	O'REILLY AUTO PARTS	\$395.66		
98586	06/17/2021	Open			Accounts Payable	OFFICE NATION, INC.	\$9,274.45		
98587	06/17/2021	Open			Accounts Payable	PIONEER TITLE AGENCY, INC	\$300.00		
98588	06/17/2021	Open			Accounts Payable	POTENCIANO, GILBERT BONIFACIO	\$59.00		
98589	06/17/2021	Open			Accounts Payable	PURCELL TIRE CO.	\$479.98		
98590	06/17/2021	Open			Accounts Payable	QUINONEZ, FRANCISCO	\$150.00		
98591	06/17/2021	Open			Accounts Payable	RAMCAT ENTERPRISE	\$350.00		
98592	06/17/2021	Open			Accounts Payable	RDO EQUIPMENT CO.	\$25.87		
98593	06/17/2021	Open			Accounts Payable	REAL PURIFIED WATER LLC	\$24.17		
98594	06/17/2021	Open			Accounts Payable	REYNAGA, ANDRES	\$133.00		
98595	06/17/2021	Open			Accounts Payable	RM GRAPHICS	\$94.00		
98596	06/17/2021	Open			Accounts Payable	RUIZ, OSCAR	\$1,850.00		
98597	06/17/2021	Open			Accounts Payable	SAFETY-KLEEN SYSTEMS, INC	\$228.00		
98598	06/17/2021	Open			Accounts Payable	SAN LUIS AIR CONDITIONING LLC	\$800.00		
98599	06/17/2021	Open			Accounts Payable	SHUMAKER, JON, MICHAEL	\$4,400.00		
98600	06/17/2021	Open			Accounts Payable	SIERRA COATINGS, LLC	\$8,500.00		
98601	06/17/2021	Open			Accounts Payable	SKAGGS COMPANIES, INC	\$81.23		
98602	06/17/2021	Open			Accounts Payable	SMITH, RALPH E. SR.	\$1,650.00		
98603	06/17/2021	Open			Accounts Payable	SOUTH YUMA COUNTY LANDFILL	\$16,834.59		
98604	06/17/2021	Open			Accounts Payable	SOUTHERN TIRE MART LLC	\$1,075.86		
98605	06/17/2021	Open			Accounts Payable	SOUTHWEST ENTRANCES, INC	\$650.00		
98606	06/17/2021	Open			Accounts Payable	SPECTRUM BUSINESS	\$3,424.42		
98607	06/17/2021	Open			Accounts Payable	STANDARD PRINTING COMPANY, INC	\$1,384.19		
98608	06/17/2021	Open			Accounts Payable	SUPREME PLUMBING SOLUTIONS LLC	\$4,500.00		
98609	06/17/2021	Open			Accounts Payable	SWIFT GROUP LLC	\$1,491.47		
98610	06/17/2021	Open			Accounts Payable	TELEFLEX MEDICAL INCORPORATED	\$748.73		
98611	06/17/2021	Open			Accounts Payable	THOMAS, CHRISTOPHER SETH RONALD	\$22.00		
98612	06/17/2021	Open			Accounts Payable	TOVAR, ANGELICA	\$36.56		
98613	06/17/2021	Open			Accounts Payable	ULINE, INC.	\$93.06		
98614	06/17/2021	Open			Accounts Payable	ULTRA SHOW MAKERS LLC	\$9,300.66		
98615	06/17/2021	Open			Accounts Payable	US POST MASTER	\$2,860.29		
98616	06/17/2021	Open			Accounts Payable	USA BLUE BOOK	\$785.17		

Payment Register

From Payment Date: 6/14/2021 - To Payment Date: 6/17/2021

Number	Date	Status	Void Reason	Reconciled/ Voided Date	Source	Payee Name	Transaction Amount	Reconciled Amount	Difference
98617	06/17/2021	Open			Accounts Payable	V&L LANDSCAPING AND GREEN MAINTENANCE LLC	\$4,030.00		
98618	06/17/2021	Open			Accounts Payable	VALLEJO CUADROS, MANUEL	\$383.00		
98619	06/17/2021	Open			Accounts Payable	VAPEX ENVIRONMENTAL TECHNOLOGIES, LLC	\$64.77		
98620	06/17/2021	Open			Accounts Payable	WAXIE SANITARY SUPPLY	\$114.79		
98621	06/17/2021	Open			Accounts Payable	WESTERN SUN SYSTEMS, INC	\$315.00		
98622	06/17/2021	Open			Accounts Payable	WIZARD EDUCATION	\$595.00		
98623	06/17/2021	Open			Accounts Payable	YUMA NURSERY SUPPLY	\$756.36		
98624	06/17/2021	Open			Accounts Payable	YUMA SUN INC	\$182.01		
98625	06/17/2021	Open			Accounts Payable	YUMA TRUCK PARTS	\$266.58		
98626	06/17/2021	Open			Accounts Payable	YUMA WINLECTRIC CO.	\$88.79		
98627	06/17/2021	Open			Accounts Payable	YUMA WINNELSON CO.	\$1,820.46		
							\$373,114.91		

Type Check Totals:
1BPAYABLE - 1st BY Accounts Payable Totals

Checks	Status	Count	Transaction Amount	Reconciled Amount
	Open	99	\$373,114.91	\$0.00
	Reconciled	0	\$0.00	\$0.00
	Voided	0	\$0.00	\$0.00
	Stopped	0	\$0.00	\$0.00
	Total	99	\$373,114.91	\$0.00

All	Status	Count	Transaction Amount	Reconciled Amount
	Open	99	\$373,114.91	\$0.00
	Reconciled	0	\$0.00	\$0.00
	Voided	0	\$0.00	\$0.00
	Stopped	0	\$0.00	\$0.00
	Total	99	\$373,114.91	\$0.00

Grand Totals:

Checks	Status	Count	Transaction Amount	Reconciled Amount
	Open	99	\$373,114.91	\$0.00
	Reconciled	0	\$0.00	\$0.00
	Voided	0	\$0.00	\$0.00
	Stopped	0	\$0.00	\$0.00
	Total	99	\$373,114.91	\$0.00
All	Status	Count	Transaction Amount	Reconciled Amount
	Open	99	\$373,114.91	\$0.00
	Reconciled	0	\$0.00	\$0.00
	Voided	0	\$0.00	\$0.00
	Stopped	0	\$0.00	\$0.00
	Total	99	\$373,114.91	\$0.00

Digitally signed by:
David Espitia
DN: CN = David Espitia
email =
despitia@sanluisaz.
gov O = AD O = City of
San Luis OU = Finance
/Date: 2021.06.21 07:
09:46 -07'00'



Pay Day Register

Pay Date Range 06/16/21 - 06/16/21

Pay Batch 202106FH

Pay Batch 202106FH Total

Employees in Pay Batch 42

Female Employees in Pay Batch 2

Hours Description	Hours	Gross	Withholdings and Deductions	Gross Base	Benefits	Gross Base
705 - FIRE HOLIDAY PAYOFF	4,204.7667	76,156.03	Gross	76,156.03	PSPRS FIRE DB NORM - TIER 1	46,920.89
Total	4,204.7667	\$76,156.03	Imputed Income		PSPRS FIRE DB NORM - TIER 2	4,072.83
			FEDERAL TAX WITHHOLDING	5,200.59	PSPRS FIRE DB NORM - TIER 3	24,080.09
			SOCIAL SECURITY TAX	4,721.68	PSPRS FIRE DB UNFUND - TIER	46,920.89
			MEDICARE	1,104.29	PSPRS FIRE DB UNFUND - TIER	4,072.83
			STATE WITHHOLDING	2,211.99	PSPRS FIRE DB UNFUND - TIER	24,844.53
			PSPRS FIRE DB RATE - TIER 1a	2,866.22	PSPRS FIRE DCCN - TIER 3	764.44
			PSPRS FIRE DB RATE - TIER 1b	1,101.42	PSPRS FIRE DISABILITY - TIER	764.44
			PSPRS FIRE DB RATE - TIER 2	474.49	Total	\$13,457.60
			PSPRS FIRE DB RATE - TIER 3	2,393.53	Workers' Comp	
			PSPRS FIRE DC RATE - TIER 3	68.80	Gross Base	
			PSPRS FIRE DISABILITY RATE	10.78	FIREFIGHTERS & DRIVERS	3,335.60
			Net	\$56,002.24	Total	\$3,335.60

Monica
Castro

Digitally signed by Monica Castro
DN: cn = Monica Castro email =
/c=US/st=CA/ou=AD
Date: 2021.06.15 12:08:57 -0700

Direct Deposits	Amount
Check	\$56,002.24

Schedule B



Pay Day Register

Pay Date Range 06/05/21 - 06/18/21
Pay Batch 202113

Monica
Castro

Digitally signed by Monica Castro
DN: cn = Monica Castro email =
mcastro@sanraja.gov C = AZ
Date: 2021.06.23 06:56:52 -0700

PSPRS FIRE DB RATE - TIER 3	2,487.91	25,029.49	BUILDING- NOC OPER BY	1,125.58	31,092.95
PSPRS FIRE DC RATE - TIER 3	163.52	1,816.84	BUS COMPANY AND DRIVERS	152.32	2,759.40
PSPRS FIRE DISABILITY RATE	25.62	1,816.84	CLERICAL OFFICE/ LIBRARY/	279.66	116,520.27
PSPRS POLICE DB RATE - TIER	3,235.89	42,299.28	Electrician	59.11	1,882.40
PSPRS POLICE DB RATE - TIER	2,245.35	19,273.42	FIREFIGHTERS & DRIVERS	3,958.21	90,368.90
PSPRS POLICE DB RATE - TIER 2	995.01	8,540.87	GARBAGE/ ASH/ REFUSE	280.10	4,481.60
PSPRS POLICE DB RATE - TIER 3	2,316.63	23,305.99	Homemaker Service	17.16	749.26
STANDARD LIFE ADDTNL	979.43	.00	MUNICIPAL/ TOWN/	77.88	4,450.00
TRANSWESTERN MEXICAN	97.00	.00	PARKS- NOC ALL EMPLOYEES	605.37	19,528.05
U.S. MEX DENTAL - EE &	574.84	.00	POLICE OFFICERS	4,164.76	95,085.25
U.S. MEX DENTAL - EE &	164.24	.00	RECREATION- ALL EMPLOYEES/	235.43	17,184.47
UNITED WAY	14.00	.00	SEWAGE DISPOSAL/ PLANT	670.06	19,478.98
US & MEX DENTAL= FAMILY	691.74	.00	Street or Road Construction	1,816.81	22,624.93
US & MEX HEALTH = C	5,408.92	.00	WATERWORKS OPERATIONS	606.54	17,479.25
US & MEX HEALTH = FAMILY	6,967.68	.00	Total	<u>\$14,412.79</u>	
US & MEX HEALTH = SP	1,708.08	.00			
VSP - VISION CHILDREN	227.15	.00	Direct Deposits		Amount
VSP - VISION FAMILY	376.41	.00	1st Bank Yuma		29,015.93
VSP - VISION SPOUSE	110.33	.00	ACADEMY BANK		2,449.36
Net	<u>\$329,561.67</u>		Bank of America		2,685.19
			Bankcorp		150.00
			Charles Sch		200.00
			Chase Bank		158,999.15
			chase centro		1,036.06
			Federal Credit Union		32,727.04
			FF CREDIT UNION		1,744.01
			FIREFIGHTER FIRST CREDIT UNION		5,501.51
			FIRST NATIONAL BANK TEXAS		1,551.90
			GREEN DOT BANK		408.57
			MIT FEDERAL CREDIT UNION		365.89
			National Bank		2,949.48
			Navy Federal		17,293.69
			NetSpend Corporation DD		120.00
			NORTH ISLAND CREDIT UNION		715.16
			Sunbank		1,198.54
			THE FOOTHILLS BANK		449.43
			USAA FEDERAL SAVING		3,061.46
			WASHINGTON FEDERAL		986.84
			Wells Fargo		64,417.31
			WELLS FARGO CA		1,204.87
			Total		<u>\$329,231.39</u>
			Check		\$330.28

Schedule C

Payment Register

From Payment Date: 6/21/2021 - To Payment Date: 6/24/2021

Number	Date	Status	Void Reason	Reconciled/ Voided Date	Source	Payee Name	Transaction Amount	Reconciled Amount	Difference
1BYPAYABLE - 1st BY Accounts Payable									
Check									
98629	06/21/2021	Open			Utility Management Refund	CL TECHNOLOGIES, LLC/ HAZAEL PEREZ	\$200.77		
98630	06/21/2021	Open			Utility Management Refund	CORREA, ENRIQUE	\$150.77		
98631	06/21/2021	Open			Utility Management Refund	GAXIOLA, MARIA & JESUS	\$266.61		
98632	06/21/2021	Open			Utility Management Refund	HERNANDEZ, RAMON & DORA	\$7.95		
98633	06/21/2021	Open			Utility Management Refund	HUGHES, VERONICA	\$21.52		
98634	06/21/2021	Open			Utility Management Refund	JAIMES, MARTIN & JESSICA RAMIREZ	\$162.11		
98635	06/21/2021	Open			Utility Management Refund	JIMENEZ, MOISES & NORIEGA IRMA	\$273.85		
98636	06/21/2021	Open			Utility Management Refund	LANDEROS, LUIS, M	\$76.77		
98637	06/21/2021	Open			Utility Management Refund	MANNINGS, MARTHA, E	\$52.82		
98638	06/21/2021	Open			Utility Management Refund	MARTINEZ, PHILIP	\$6.50		
98639	06/21/2021	Open			Utility Management Refund	NUNEZ, LAURA	\$164.25		
98640	06/21/2021	Open			Utility Management Refund	PASILLAS GUSTAVO & NERY ANDRADE	\$40.29		
98641	06/21/2021	Open			Utility Management Refund	PEREZ, MARIO & BERTHA RUIZ	\$115.87		
98642	06/21/2021	Open			Utility Management Refund	RENDON, ANSELMO & ROSA	\$21.53		
98643	06/21/2021	Open			Utility Management Refund	RODRIGUEZ, JUAN & SANDRA	\$84.26		
98644	06/21/2021	Open			Utility Management Refund	ZAMUDIO, ALMA, R	\$216.62		
98645	06/22/2021	Open			Accounts Payable	BILL ALEXANDER FORD	\$37,502.11		
98646	06/23/2021	Open			Accounts Payable	BALSINO, PETER, M	\$262.49		
98647	06/23/2021	Open			Accounts Payable	CHARGO PA, GURSTEL	\$26.95		
98648	06/23/2021	Open			Accounts Payable	FOP/ALC	\$375.00		
98649	06/23/2021	Open			Accounts Payable	GARCIA & CORNEJO, SERGIO & OSCAR	\$311.10		
98650	06/23/2021	Open			Accounts Payable	SAN LUIS POLICE OFFICERS ASSOC	\$345.00		
98651	06/23/2021	Open			Accounts Payable	STANDARD INSURANCE COMPANY	\$8,813.13		
98652	06/23/2021	Open			Accounts Payable	SUPPORT PAYMENT CLEARINGHOUSE	\$3,036.72		
98653	06/23/2021	Open			Accounts Payable	UNITED WAY OF YUMA COUNTY INC.	\$14.00		
98654	06/23/2021	Open			Accounts Payable	UNITED YUMA FIRE FIGHTERS ASSOC	\$98.50		
98655	06/23/2021	Open			Accounts Payable	UNITED YUMA FIRE FIGHTERS-IAFF	\$950.00		
98656	06/24/2021	Open			Accounts Payable	24 KARAT JEWELERS	\$216.61		

Payment Register

From Payment Date: 6/21/2021 - To Payment Date: 6/24/2021

Number	Date	Status	Void Reason	Reconciled/ Voided Date	Source	Payee Name	Transaction Amount	Reconciled Amount	Difference
98657	06/24/2021	Open			Accounts Payable	ALSCO, INC	\$250.89		
98658	06/24/2021	Open			Accounts Payable	AMAO, DONNA	\$231.00		
98659	06/24/2021	Open			Accounts Payable	AMAZON.COM SALES, INC.	\$65.06		
98660	06/24/2021	Open			Accounts Payable	ANGEL'S TOWING SERVICE/AUTO SALES	\$75.00		
98661	06/24/2021	Open			Accounts Payable	APPLIED PRODUCTS GROUP LLC	\$10,911.51		
98662	06/24/2021	Open			Accounts Payable	ARIZONA AUTOMOTIVE EQUIPMENT LLC	\$1,041.00		
98663	06/24/2021	Open			Accounts Payable	ARIZONA MUNICIPAL CLERK'S ASSOCIATION	\$395.00		
98664	06/24/2021	Open			Accounts Payable	ARIZONA PUBLIC SERVICE	\$36.76		
98665	06/24/2021	Open			Accounts Payable	AUTOZONE STORES, INC	\$922.98		
98666	06/24/2021	Open			Accounts Payable	AVALOS, MARIELA	\$134.50		
98667	06/24/2021	Open			Accounts Payable	BILL ALEXANDER FORD	\$108.39		
98668	06/24/2021	Open			Accounts Payable	BINGHAM EQUIPMENT CO	\$47.06		
98669	06/24/2021	Open			Accounts Payable	BLUE STREAK SIGNS, LLC	\$60.17		
98670	06/24/2021	Open			Accounts Payable	BORREGO BROTHERS, INC	\$11,858.42		
98671	06/24/2021	Open			Accounts Payable	BUNGER STEEL, INC	\$51,604.00		
98672	06/24/2021	Open			Accounts Payable	CABLE & WIRELESS TECHNOLOGIES, INC	\$3,682.56		
98673	06/24/2021	Open			Accounts Payable	CAMPOS, LUIS ALFREDO	\$225.67		
98674	06/24/2021	Open			Accounts Payable	CDWG	\$742.74		
98675	06/24/2021	Open			Accounts Payable	CENTURYLINK	\$9,141.19		
98676	06/24/2021	Open			Accounts Payable	DANA KEPNER COMPANY LLC	\$4,882.80		
98677	06/24/2021	Open			Accounts Payable	DESERT VALLEY SERVICES, INC	\$3,325.87		
98678	06/24/2021	Open			Accounts Payable	DESERT WATER STORE INC	\$86.34		
98679	06/24/2021	Open			Accounts Payable	DESTINY SOFTWARE, INC	\$6,200.00		
98680	06/24/2021	Open			Accounts Payable	ESPINOZA, KEVIN	\$429.90		
98681	06/24/2021	Open			Accounts Payable	FISHER CHRYSLER DODGE JEEP	\$593.44		
98682	06/24/2021	Open			Accounts Payable	FNP-C & ASSOCIATES PLLC	\$90.00		
98683	06/24/2021	Open			Accounts Payable	FRESH TERRA SERVICES LLC	\$240.00		
98684	06/24/2021	Open			Accounts Payable	GIMBUT, GLENN J.	\$91.00		
98685	06/24/2021	Open			Accounts Payable	HERNANDEZ, JERRY	\$400.00		
98686	06/24/2021	Open			Accounts Payable	HILL BROTHERS CHEMICAL CO.	\$2,834.46		
98687	06/24/2021	Open			Accounts Payable	HOPPSTETTER'S OFFICE CITY	\$1,841.08		
98688	06/24/2021	Open			Accounts Payable	IMAC ROCK AND LANDSCAPE LLC	\$1,177.76		
98689	06/24/2021	Open			Accounts Payable	JAMES DAVEY AND ASSOCIATES INC	\$5,712.50		
98690	06/24/2021	Open			Accounts Payable	JESSUP, RICHARD	\$51.97		
98691	06/24/2021	Open			Accounts Payable	KIMLEY-HORN AND ASSOCIATES INC	\$14,185.50		
98692	06/24/2021	Open			Accounts Payable	LEERS	\$287.85		
98693	06/24/2021	Open			Accounts Payable	LESLIE'S POOL SUPPLY INC.	\$512.83		
98694	06/24/2021	Open			Accounts Payable	LOOMIS	\$814.81		
98695	06/24/2021	Open			Accounts Payable	LOWE'S HIW, INC.	\$1,524.56		
98696	06/24/2021	Open			Accounts Payable	MACHADO, IVAN & AIXIA GUTIERREZ	\$700.00		
98697	06/24/2021	Open			Accounts Payable	METRO FIRE EQUIPMENT INC	\$117.00		
98698	06/24/2021	Open			Accounts Payable	MOLINA, YOLANDA	\$1,014.75		
98699	06/24/2021	Open			Accounts Payable	MOTOROLA SOLUTIONS, INC	\$1,769.95		
98700	06/24/2021	Open			Accounts Payable	O'REILLY AUTO PARTS	\$8.95		

Payment Register

From Payment Date: 6/21/2021 - To Payment Date: 6/24/2021

Number	Date	Status	Void Reason	Reconciled/ Voided Date	Source	Payee Name	Transaction Amount	Reconciled Amount	Difference
98701	06/24/2021	Open			Accounts Payable	OFFICE DEPOT	\$1,229.15		
98702	06/24/2021	Open			Accounts Payable	PENN NEON SIGN CO., INC.	\$1,208.80		
98703	06/24/2021	Open			Accounts Payable	PIONEER TITLE AGENCY, INC	\$400.00		
98704	06/24/2021	Open			Accounts Payable	POLAR ICE LLC	\$316.08		
98705	06/24/2021	Open			Accounts Payable	PROFORCE LAW ENFORCEMENT	\$15.40		
98706	06/24/2021	Open			Accounts Payable	QUALIFICATION TARGETS, INC.	\$304.89		
98707	06/24/2021	Open			Accounts Payable	QUINONES TIRES LLC	\$10.00		
98708	06/24/2021	Open			Accounts Payable	QUINONEZ, FRANCISCO	\$200.00		
98709	06/24/2021	Open			Accounts Payable	REAL PURIFIED WATER LLC	\$40.14		
98710	06/24/2021	Open			Accounts Payable	RIEDEL CONSTRUCTION	\$519.25		
98711	06/24/2021	Open			Accounts Payable	RIVAS, RICARDO	\$100.00		
98712	06/24/2021	Open			Accounts Payable	RM GRAPHICS	\$123.50		
98713	06/24/2021	Open			Accounts Payable	ROACH PEST CONTROL	\$30.00		
98714	06/24/2021	Open			Accounts Payable	RODRIGUEZ, DANIEL	\$596.27		
98715	06/24/2021	Open			Accounts Payable	RODRIGUEZ, DANIEL	\$975.71		
98716	06/24/2021	Open			Accounts Payable	SAN DIEGO POLICE EQUIPMENT CO.	\$3,049.95		
98717	06/24/2021	Open			Accounts Payable	SAN LUIS AIR CONDITIONING LLC	\$820.00		
98718	06/24/2021	Open			Accounts Payable	SANCHEZ, ERIKA	\$65.50		
98719	06/24/2021	Open			Accounts Payable	SKAGGS COMPANIES, INC	\$1,419.77		
98720	06/24/2021	Open			Accounts Payable	SOUTHERN TIRE MART LLC	\$1,444.45		
98721	06/24/2021	Open			Accounts Payable	SOUTHWEST SANITATION SERVICES, LLC	\$274.00		
98722	06/24/2021	Open			Accounts Payable	SPECIALIST ID, INC	\$560.20		
98723	06/24/2021	Open			Accounts Payable	SPECTRUM BUSINESS	\$3,424.42		
98724	06/24/2021	Open			Accounts Payable	THE HOME DEPOT	\$542.79		
98725	06/24/2021	Open			Accounts Payable	THOMSON WEST PUBLISHING CO.	\$1,059.41		
98726	06/24/2021	Open			Accounts Payable	TRUCKPRO, LLC	\$3,269.98		
98727	06/24/2021	Open			Accounts Payable	TYLER TECHNOLOGIES, INC.	\$700.00		
98728	06/24/2021	Open			Accounts Payable	W.W.GRAINGER, INC	\$115.25		
98729	06/24/2021	Open			Accounts Payable	WAXIE SANITARY SUPPLY	\$1,407.24		
98730	06/24/2021	Open			Accounts Payable	YUMA CO. AIRPORT AUTHORITY INC	\$167.79		
98731	06/24/2021	Open			Accounts Payable	YUMA PRINTING COMPANY	\$209.16		
98732	06/24/2021	Open			Accounts Payable	YUMA SUN INC	\$111.00		
98733	06/24/2021	Open			Accounts Payable	YUMA TRUCK PARTS	\$12,447.12		
98734	06/24/2021	Open			Accounts Payable	RARE MEDIA INC	\$2,500.00		

Payment Register

From Payment Date: 6/21/2021 - To Payment Date: 6/24/2021

Number	Date	Status	Void Reason	Reconciled/ Voided Date	Source	Payee Name	Transaction Amount	Reconciled Amount	Difference
Type Check Totals:					106 Transactions		\$233,898.54		
1BYPAYABLE - 1st BY Accounts Payable Totals									

Checks	Status	Count	Transaction Amount	Reconciled Amount
	Open	106	\$233,898.54	\$0.00
	Reconciled	0	\$0.00	\$0.00
	Voided	0	\$0.00	\$0.00
	Stopped	0	\$0.00	\$0.00
	Total	106	\$233,898.54	\$0.00

All	Status	Count	Transaction Amount	Reconciled Amount
	Open	106	\$233,898.54	\$0.00
	Reconciled	0	\$0.00	\$0.00
	Voided	0	\$0.00	\$0.00
	Stopped	0	\$0.00	\$0.00
	Total	106	\$233,898.54	\$0.00

Grand Totals:

Checks	Status	Count	Transaction Amount	Reconciled Amount
	Open	106	\$233,898.54	\$0.00
	Reconciled	0	\$0.00	\$0.00
	Voided	0	\$0.00	\$0.00
	Stopped	0	\$0.00	\$0.00
	Total	106	\$233,898.54	\$0.00

All	Status	Count	Transaction Amount	Reconciled Amount
	Open	106	\$233,898.54	\$0.00
	Reconciled	0	\$0.00	\$0.00
	Voided	0	\$0.00	\$0.00
	Stopped	0	\$0.00	\$0.00
	Total	106	\$233,898.54	\$0.00

Digitally signed by: David Espitia
 DN: CN = David Espitia
 email = despitia@sanluisaz.gov
 C = AD O = City of San Luis OU = Finance
 Date: 2021.06.24 17:46:01 -0700



AGENDA ITEM REVIEW FORM

Regular City Council Meeting

5. A.

Meeting Date: 07/14/2021

Department Head: James Einwaechter, Assistant Director of Public Works, Public Works Department

Submitted By: James Einwaechter, Assistant Director of Public Works, Public Works Department

Action Requested: Motion

ITEM:

Discussion and possible action on any and all matters regarding the purchase of a new 2022 Peterbilt Solid Waste Truck with Scorpion body (side-loader) for the Public Works Department's Solid Waste Division. **(James R. Einwaechter, Assistant Director of Public Works).**

SUMMARY:

A new side-loading solid waste truck is required to replace an old deteriorating truck that is posing reliability/maintainability concerns and incurring increasing operation and maintenance costs for the City of San Luis. Compatible replacement parts are becoming increasingly difficult to source for our older solid waste vehicles. We received a non-competitive quote from Rush Truck Centers in the amount of \$330,587.60 for a new solid waste truck that meets the City's requirements and specifications, "mirroring" the specifications for the City's most recent solid waste truck purchase. Rush Truck Centers is the only vendor that provides both the sale and service (maintenance and repair) of new solid waste trucks in the State of Arizona. This vendor can also satisfy our requirement for a specific truck and body (side-loader) type, critical to our Fleet Services Division's ability to more efficiently and cost-effectively maintain an inventory of "like" vehicle and equipment assets. For these reasons, we recommend sole source procurement from Rush Truck Centers and the waiving of formal procurement procedures as allowed under City Code Section 3.05.010(H). This new truck was part of the Public Works Department's FY 2022 CIP request, which was recently approved by the Council in its adoption of the City's FY 2022 budget. The current quote of \$330,587.60 represents an increase to the \$312,530.86 estimate included in Public Work's FY 2022 budget request. The increase is attributable to increased manufacturing costs (particularly the price of steel). FY 2022 funds are available to transfer from multiple Solid Waste accounts to support the required \$18,056.74 budget transfer (that has already been initiated).

RECOMMENDATION / SUGGESTED MOTION:

I MOVE TO APPROVE THE PURCHASE OF A NEW SOLID WASTE TRUCK WITH SCORPION BODY IN THE AMOUNT OF \$330,587.60 FROM RUSH TRUCK CENTERS, APPROVE THE LOAN AND TRANSFER OF \$18,056.74 SHOWN ON THE FISCAL IMPACT STATEMENT AND TO WAIVE FORMAL PURCHASING PROCEDURES AS ALLOWED UNDER CITY CODE SECTION 3.05.010(H) FOR THE REASONS PRESENTED.

Fiscal Impact

IS THERE FISCAL IMPACT ASSOCIATED WITH THIS ITEM:	YES
CITY/STATE/FEDERAL FUNDS:	CITY
TOTAL:	\$330,587.60
BUDGETED AMOUNT:	\$312,530.86

AVAILABLE AMOUNT TO TRANSFER:

\$18,056.74

ACCT NAME & GL#/REMAINING BALANCE BEFORE PURCHASE: Solid Waste G/L
320-321-90000, Capital
Outlay-Equipment

FISCAL IMPACT STATEMENT (IF THIS IS A BUDGET TRANSFER, YOU MUST ATTACH THE BUDGET ADJUSTMENT FORM):

This new truck is budgeted in City's FY 2022 budget.

We are requesting council approval of budget transfer of \$18,100 as stated in the attached budget transfer form.

Staff recommends the purchase of the new solid waste truck, via a 5-year loan with 1st bank of Yuma. The City would pay 10% and the loan will cover 90% of the total cost of unit.

Capital Outlay Equipment 320-321-90000 \$ 330,587.60

Attachments

Budget Transfer Form

Updated Solid Waste Truck Quote



City of San Luis Budget Adjustment Form

Reason for Budget Adjustment: Funds transfer for purchase of new solid waste truck – Cost increase is attributable to an increase in manufacturing costs (steel) since the original March 2021 quote from vendor.

Account Number	Account Name	Approved/Amended Budget Fiscal 21/22	Budget to be revised (Add to)	Budget to be decreased (Taken from)	Available Balance Budget FY 21/22
320-321-60005	Other Supplies	\$45,000.00		\$8,000.00	\$37,000.00
320-321-70005	Gas/Oil	\$50,000.00		\$5,100.00	\$44,900.00
320-321-70025	Maintenance - Other	\$3,000.00		\$1,000.00	\$2,000.00
320-321-70040	Software Support	\$5,900.00		\$1,000.00	\$4,900.00
320-321-80000	Contractual Services	\$6,750.00		\$3,000.00	\$3,750.00
320-321-90000	Capital Outlay-Equipment	\$324,620.00	\$18,100.00		\$342,620.00
			\$18,100.00	\$18,100.00	

Department Head _____

Date _____

City Manager _____

Date _____

Finance Department _____

Date _____



Yuma AZ
 3382 E. Gila Ridge Rd.
 Yuma, AZ 85365
 928-726-9818

Customer Proposal Letter

City of San Luis
 1090 E. Union Street
 San Luis, AZ 85349
 (928) 341-8589

Salvador Sandoval, thank you for the opportunity to earn your business. We look forward to working with you on your business needs. Please accept the following proposal.

VEHICLE

Make Peterbilt Model 520 Year 2023 Stock Number To Be Determined
 Additional Vehicle and Accessories Description To be delivered on or about _____

2023 Pete 520 Per Attached Specs.
 Scorpion Body by BTE per attached Quote.
 HGAC Contract HT06-20. Delivery approximate 330 Days from receipt of order.

Quantity	1	Total
Truck Price per Unit	\$308,843.05	\$308,843.05
F.E.T. (Factory & Dealer Paid)	\$0.00	\$0.00
Net Sales Price	\$308,843.05	\$308,843.05
Optional Extended Warranty(ies)	\$150.00	\$150.00
State Sales Tax	\$20,729.55	\$20,729.55
Documentary Fee	\$250.00	\$250.00
Administration Fee		
Vehicle Inventory Tax		
Additional Taxes	\$595.00	\$595.00
Tire Recycling Program	\$20.00	\$20.00
Battery Disposal Fee		
Out of State Vehicle Fee		
Rebate(s)		
Total Sales Price (Including Rebate(s))	\$330,587.60	\$330,587.60
Trade Allowance (see DISCLAIMER Below)		\$0.00

Sales Representative Byron Haught
 Purchaser _____ signature _____ printed name _____
 _____ signature _____ printed name _____
 _____ title _____ date _____
 Accepted by Sales Manager or General Manager _____ signature _____ printed name _____

Quote good until 9/30/2021 Note: The above Customer Proposal is a quotation only. Sale terms subject to approval of Sales Manager of Dealer.

DISCLAIMER: Any order based on this Proposal subject to Customer executing Dealer's standard form Retail Purchase Order incorporating above terms. Any documentary fees, state tax, title, registration and license fees subject to adjustment and change. Actual F.E.T. to be paid by Dealer, subject to adjustment. Any F.E.T. variance will be responsibility of Dealer. Manufacturer has reserved the right to change the price to Dealer of any vehicle not currently in Dealer's stock, without notice to Dealer. If Quoted Vehicle(s) not currently in Dealer's stock, Dealer reserves right to change Quotation Total to reflect any price increases from Manufacturer. This Proposal is based upon Dealer's current and expected inventory, which is subject to change. Dealer not obligated to retain any specific vehicles in stock, nor maintain any specific inventory level. Dealer shall not be obligated to fulfill Proposal in event quoted vehicle(s) not in stock or available within requested delivery schedule at time Proposal accepted. Dealer shall not be liable for any delay in providing or inability to provide Quoted Vehicle(s), where such inability or delay is due, in whole or in part, to any cause beyond the reasonable control of Dealer or is without the gross negligence or intended misconduct of Dealer. Above listed Trade Value based upon current appraisal of Trade Vehicle(s). Dealer may adjust Trade Value of Trade Vehicle(s) to reflect changes in condition and/or mileage of Trade Vehicle(s) between date of current appraisal and acceptance of this Proposal by Customer.



Body Company, Inc.

Jason Cell:(480) 364-6028
 WWW.btebody.com

Mailing Address
 2650 N. 32nd Ave
 Phoenix, AZ 85009

Ship to Address
 2650 N 32nd Ave
 Phoenix, AZ 85009

QUOTATION

No. 20210615002

TO: Rush Truck Centers- AZ
 9600 W Roosevelt
 Tolleson, AZ 85353
 Ref: City of San Luis, AZ Public Works

<u>DATE</u> 6/15/2021	<u>INQUIRY DATE</u> 6/12/2021	<u>TO BE SHIPPED VIA</u> Bestway
<u>F.O.B.</u> Phoenix, AZ		<u>SALESMAN</u> Jason Hurst
		<u>EST. DELIVERY</u> 2nd Qtr 2022 DOOD

IN RESPONSE TO YOUR INQUIRY, WE SUBMIT THE FOLLOWING QUOTATION

QUANTITY	STOCK NUMBER / DESCRIPTION	PRICE	AMOUNT
1	Scorpion Automated Sideload 31cy capacity, 3 axle chassis only 184"-194" usable CT, 70" minimum after-frame, standard diesel Allison 4000 series PTO clutch shift dual vane hydraulic pump 60-300 gallon belt gripper, white body, chassis black, Arms Yellow RH drive, Peterbilt 520, LST Switch control, RH door mount Complete DOT LED light package, LED work lights (hopper back left corner, facing into hopper)& (Right Fender, facing arm), Dual Oval Amber strobe lights (tailgate upper light box), Triple Oval amber flashing lights (tailgate below lower light box), 2 color camara with 7" monitor (tailgate and hopper) Monitor Right hand A- Pillar, Hydraulic fluid cooler, Hydraulic oil temp sensor (Display screen cab indicator)	\$ 128,335.50	\$ 128,335.50
	Freight from Arlington, TX to Phoenix, AZ	\$ 3,800.00	3,800.00
	Steel Surcharge	\$ 12,121.00	12,121.00
	Dock Fee	\$ 100.00	\$100.00
	1 Year Warranty		
		TOTAL	\$ 144356.50

OTHER INFORMATION

Above price does not include any Fed Excise Tax, state tax or local fees
 Terms: Due upon Delivery
 Build dates, determined on order, depending on chassis delivery and
 production schedule.

ACCEPTED: THE ABOVE PRICES, SPECIFICATIONS AND CONDITIONS ARE SATISFACTORY
 AND ARE HEREBY ACCEPTED. YOU ARE AUTHORIZED TO DO THE WORK AS SPECIFIED.
 PAYMENT WILL BE MADE AS OUTLINED ABOVE. PLEASE REFER TO ABOVE QUOTATION
 NUMBER WHEN PLACING YOUR ORDER.

THIS QUOTATION IS GOOD FOR
 15 DAYS OR UNTIL MATERIALS



Rush Trk Ctrs Of Arizona (A265)
 9600 West Roosevelt St
 Tolleson, Arizona 85353

Stock

Byron Haught
 Cell Phone:
 Office Phone: (602)422-8124
 Email: haughtb@rushenterprises.com

Stock Order

Vehicle Summary

Unit		Chassis	
Model:	Model 520	Fr Axle Load (lbs):	20000
Type:	Full Truck	Rr Axle Load (lbs):	44000
Description 1:	SAN LUIS ASL	G.C.W. (lbs):	64000
Description 2:	Clone of Chassis 111486 Model 520		
	Application	Road Conditions:	
Intended Serv.:	Refuse/Landfill	Class A (Highway)	90
Commodity:	Refuse, Scrap, Recycling	Class B (Hwy/Mtn)	10
		Class C (Off-Hwy)	0
		Class D (Off-Road)	0
Type:	Body Automated Side Loader/Push-Out	Maximum Grade:	6
Length (ft):	24	Wheelbase (in):	210
Height (ft):	13.5	Overhang (in):	70
Max Laden Weight (lbs):	1000	Fr Axle to BOC (in):	0.1
		Cab to Axle (in):	209.9
		Cab to EOF (in):	279.9
No. of Trailer Axles:	0	Overall Comb. Length (in):	337.6
Type:			
Length (ft):	0	Special Req.	
Height (ft):	0		
Kingpin Inset (in):	0		
Corner Radius (in):	0		
	Restrictions		
Length (ft):	40		
Width (in):	102		
Height (ft):	13.5		

Approved by: _____

Date: _____

Note: All sales are F.O.B. designated plant of manufacture.

Price Level: April 1, 2021
 Deal: SAN LUIS ASL
 Printed On: 3/12/2021 8:06:03 AM

Date: March 12, 2021
 Quote Number: QUO-792450-X2B2K5



Sales Code	Std/Opt	Description	\$ List	Weight
Base Model				
0005201	S	Model 520 April 1, 2021 Price Level will include the VMUX architecture and new dash, older price levels will continue to be the current model 520. See TSB 21-06 for additional information. Peterbilt's Model 520 is built to withstand the harsh demands of the refuse industry. The rugged, aluminum cab delivers best-in-class durability for increased uptime and lap seam construction on a zinc-coated steel sub-frame for corrosion resistance. Bulkhead-style doors provide years of watertight performance. This low-cab forward vehicle adds a new dimension of productivity and versatility. An industry-leading, 65-degree cab tilt enhances maintenance and serviceability. Body installation is cost effective and efficient and the center console provides convenient access to body control integration points.	201,980	16,475
0091180	S	Refuse, Scrap, Recycling	0	0
0093040	O	Refuse/Landfill Truck which picks up refuse or recycled material from curbside containers in residential areas. Operation typically includes very frequent stops and starts. Unloading can be at transfer station or at landfill (may enter landfill).	0	0
0095220	O	Automated Side Loader/Push-Out A lift-equipped truck used to pick up wheeled waste containers to load waste materials into the truck body. Requires a single operator. A hydraulic ram pushes the load out of the body.	0	0
0098170	S	United States Registry Canadian Registry Package Requires Air Conditioning Excise Tax Canada, Speedometer to be KPH ipo MPH, Daytime Running Lights and Rubber Battery Pad in Bottom of Battery Box.	0	0
Configuration				
0200700	S	Not Applicable Secondary Manufacturer	0	0
Frame & Equipment				
0514160	O	10-3/4" Steel Rails 306-342" 10.75x3.5x.375 Dimension, 2,136,000 RBM; Yield Strength: 120,000 psi. Section Modulus: 17.8 cubic inches. Weight: 1.74 lbs/inch pair	144	196
0644090	S	EOF Square without Crossmember End-of-frame square without crossmember. For use with body builder installed crossmember.	0	0
0651090	S	Omit Rear Mudflaps and Hangers	0	0
0713130	O	(2) Solid Mount Cable Hooks	0	40
Front Axle & Equipment				
1011890	S	PACCAR Steer Axle 20,000 lbs. 4" Drop	0	0

Price Level: April 1, 2021
Deal: SAN LUIS ASL
Printed On: 3/12/2021 8:06:03 AM

Date: March 12, 2021
Quote Number: QUO-792450-X2B2K5



Sales Code	Std/ Opt	Description	\$ List	Weight
		<p>Axle is designed for applications with a gross axle weight rating (GAWR) of 20,000 pounds. Front axle is designed for demanding applications such as construction, heavy haul, refuse, and other vocational uses. Robust forged steel beam construction for long-lasting performance. It utilizes innovative tapered kingpin roller bearings for more efficient operation and improved steering efficiency.</p> <p>The PACCAR Steer Axle comes standard with the PACCAR warranty of 5 years, 750,000 miles.</p>		
1114030	S	Taper Leaf Springs, Shocks 20,000 lb Standard with Heavy Resistance Shocks.	0	0
1243010	S	Power Steering Sheppard M100 Dual For use with 16,000 to 20,000 lb. axle ratings. Glidekote splines on steering shaft extend service life of components.	0	0
1353540	O	PHP10 Aluminum PreSet PLUS Hubs PHP10 aluminum PreSet PLUS hubs have a fully integrated spindle nut design, an optimized wheel spacer, magnetic fill plug on drive and trailer hubs for inspection of metal particles in lubricant, with a long life oil seal and bearings are pre-adjusted. Use with Front Axle.	-659	-179
1380280	O	Bendix Air Cam Front Drum Brakes 16.5x7 For use with 16,000 lbs to 23,000 lbs steer axles or front drive axles. Includes automatic slack adjusters & outboard mounted brake drums.	757	0
1380490	O	PACCAR Wide Track IPO Standard 71in KPI IPO 69in front axle for improved turning radius.	0	0
1391410	O	Gusseted Cam Brackets, Steer Axle	28	0
1392970	O	Heavy Duty Cam Bushings, Steer Axle	31	0
Rear Axle & Equipment				
1523330	O	Dana Spicer DSH44 44,000 lb, High Performance 44 Interaxle diff lock air rocker occupies space of one gauge. 12.5 mm housing, 15.75 ring gear. Laser factory axle alignment to improve handling & reduce tire wear. Magnetic rear axle oil drain plug captures & holds any metal fragments in drive axle lube to extend service life. Parking brakes on all drive axles for optimal performance. Cognis EMGARD® FE 75W-90 synthetic axle lube provides over 1% fuel economy improvement. Reduces wear & extends maintenance intervals, resulting in increased uptime. Provides improved fluid flow to protect components in extreme cold conditions & withstand the stress from high temperatures, extending component life.	-509	-311
1616290	O	PHP10 Aluminum PreSet PLUS Hubs	-425	0
1672630	O	Differential Lock Both Axles Air Rocker Switch Occupies the Space of One Gauge	2,058	60
1680440	O	Refuse Service Brakes, Steer And Drive Axles Designed for heavy-duty applications for refuse industry, providing long brake life, safety and performance.	0	0
1680450	O	Rear Brake Camshaft Reinforcement Rear brake camshaft reinforcement helps guard against wear and corrosion.	64	9

Price Level: April 1, 2021

Deal: SAN LUIS ASL

Printed On: 3/12/2021 8:06:03 AM

Date: March 12, 2021

Quote Number: QUO-792450-X2B2K5



Sales Code	Std/Opt	Description	\$ List	Weight
1680490	O	Gusseted Cam Brackets, Drive Axle(s)	72	2
1680500	S	SBM Valve Full trucks require a spring brake modulation (SBM) system for emergency braking application. This system requires an SBM valve and a relay valve with spring brakes on the rear axles. The SBM valve allows the foot valve to operate the rear axle spring brakes if a failure exists in the rear air system.	0	0
1680745	O	Bendix ESP Electronic Stability Program With ATC - Model 520 Refuse Body	523	29
1682710	O	Anti-Lock Braking System (ABS) 6S6M ABS-6. Includes air braking system.	454	35
1684200	S	Synthetic Axle Lubricant All Axles Peterbilt heavy duty models include Fuel Efficient Cognis EMGARD FE75W-90 which provides customers performance advantages over current synthetic lubricants with reduced gear wear and extended maintenance intervals, resulting in increased uptime. In addition, the lubricant provides improved fluid flow to protect gears in extreme cold conditions and withstand the stress from high temperatures, extending component life.	0	0
1687020	O	Bendix Air Cam Rear Drum Brakes 16.5x8.6 Bendix Air Cam Rear Drum Brakes to fit all heavy haul, construction, refuse and highway truck and tractor applications. Includes Automatic Slack Adjusters & Outboard Mounted Brake Drums. Refer to TSB 11-57 for more information.	-912	0
1705570	O	Ratio 5.57 Rear Axle	0	0
1824410	O	Hendrickson HMX EX 460 46,000 LBS., 54" Haulmaax, 70K Creep Rating. Includes Traax Rod as standard, option 1920905 is not needed or available. Progressive load spring system easily adjusts to the load for an enhanced combination of empty-ride quality and loaded stability.	820	-67
1911010	S	Steel Suspension Insert Up To 77" Overhang	0	-239

Engine & Equipment

2074513	O	PACCAR PX-9 370@1900 GOV@2100 1250@1200 Performance (2021 Emissions)	2,587	0
		N21350 C121 64....Maximum Accelerator Pedal Ve		
		N21370 C128 64....Maximum Cruise Speed (P059)		
		N21460 C132 1400..Max PTO Speed (P046)		
		N21520 C133 5.....Timer Setting (P030)		
		N21610 C188 39....Low Ambient Temperature Thre		
		N21630 C190 80....High Ambient Temperature Thr		
		N21510 C225 YES...Enable Idle Shutdown Park Br		
		N21450 C231 NO....Gear Down Protection (P026)		
		N21570 C233 NO....Idle Shutdown Manual Overrul		
		N21440 C234 YES...Engine Protection Shutdown (
		N21480 C238 NO....Auto Engine Brake in Cruise		
		N21470 C239 NO....Cruise Control Auto Resume (

Price Level: April 1, 2021

Deal: SAN LUIS ASL

Printed On: 3/12/2021 8:06:03 AM

Date: March 12, 2021

Quote Number: QUO-792450-X282K5



Sales Code	Std/ Opt	Description	\$ List	Weight
		N21590 C382 YES...Enable Hot Ambient Automatic		
		N21530 C396 YES...Enable Impending Shutdown Wa		
		N21540 C397 60....Timer For Impending Shutdown		
		N21620 C189 60....Intermediate Ambient Tempera		
		N21550 C206 35....Engine Load Threshold (P516)		
		N21340 C209 120...Hard Maximum Speed Limit (P1		
		N21430 C333 0.....Reserve Speed Limit Offset (
		N21410 C334 0.....Maximum Cycle Distance (N202		
		N21500 C395 0.....Expiration Distance (N209)		
		N21320 C399 120...Standard Maximum Speed Limit		
		N21400 C400 252...Reserve Speed Function Reset		
		N21420 C401 10....Maximum Active Distance (N20		
		N21330 C402 0.....Expiration Distance (N207)		
2091130	S	VMUX Electronics Architecture	0	0
2091310	O	Engine Idle Shutdown Timer Disabled	0	0
2091315	O	Enable EIST Ambient Temp Overrule	0	0
2091372		Eff EIST NA Expiration Miles	0	0
2091640		Effective VSL Setting NA	0	0
2092016	O	Typical Operating Speed 62 MPH	0	0
2092033	O	Powertrain Optimized for Balance Best analysis for vehicles where service includes frequent start and stop cycles.	0	0
2140150	O	Remote PTO and Throttle Provision 12-pin connector on engine harness.	38	0
2140200	O	CARB Engine Idling Compliance PACCAR PX-7, PX-9 and MX, Cummins X15 and ISX diesel engines will include the required factory installed serialized sticker on the drivers door to identify them as meeting the NOx idling standard.	0	0
2140450	O	Remote PTO/Throttle, 12-Pin, Eng Bay Remote Control Provision	11	0
2147460	S	Bed Plate for PX-9, L9N Engines Designed to increase engine longevity by incorporating a stiffener bracket on the bottom side of the engine, inside the oil pan, for additional reinforcement. Required for all PX-9/L9N refuse applications and recommended for other high load 9-liter applications.	0	0
2513060	S	PACCAR 160 Amp Alternator, Brushed PACCAR 160 AMP alternator, brushed producing 160 Amps at road speed and 100 Amps at idle.	0	0
2521090	O	Immersion Type Block Heater 110-120V Standard location for 2.1M and 1.9M models is left-hand under cab, Model 520 is in bumper, and for Model 220 it is at the driver step. Plug includes a weather-proof cover that protects the receptacle. This pre-	80	2

Price Level: April 1, 2021

Deal: SAN LUIS ASL

Printed On: 3/12/2021 8:06:03 AM

Date: March 12, 2021

Quote Number: QUO-792450-X2B2K5



Sales Code	Std/ Opt	Description	\$ List	Weight
		heater keeps the coolant in the engine block from freezing when the engine is not running.		
2522110	O	PACCAR 12V Starter, N/A PACCAR MX Engines PACCAR 12-volt electrical system. With centralized power distribution incorporating plug-in style relays. Circuit protection for serviceability, 12-volt light system w/circuit protection circuits number & color coded.	0	0
2538040	S	3 PACCAR Premium 12V Dual Purpose Batt 2190 CCA Threaded stud type terminal. Stranded copper battery cables are double aught (00) or larger to reduce resistance.	0	0
2539740	O	Kissling Battery Disconnect Switch, 300 amp Mounted on battery box	160	3
2621000	S	2-Speed Fan Clutch For Frequent Start/Stops A 2-speed fan clutch is ideal for vocational applications where the fan clutch engagement time exceeds 10% of the engine run time. When the fan clutch is disengaged, the fan still rotates at 15-25% of the engine RPM. This fan rotation provides crucial airflow to the engine and draws virtually no horsepower.	0	0
2723210	S	18.7 CFM Air Compressor N/A X15. Furnished on engine. Teflon lined stainless steel braided compressor discharge line.	0	0
2921110	S	PACCAR Fuel/Water Separator Standard Service PACCAR Fuel/Water separator standard service intervals. High efficiency media protects critical engine components.	0	0
2921210	S	No Fluid Heat Option for Fuel Filter	0	0
2921310	S	No Electric Heat Option for Fuel Filter	0	0
3010400	O	Engine Protection Shutdown w/ Label Includes oil pressure, oil temperature, coolant temperature, and intake manifold temperature.	10	0
3114270	S	High Efficiency Cooling System Cooling module is a combination of steel and aluminum components, with aluminum connections to maximize performance and cooling capability. Silicone radiator & heater hoses enhance value, durability, & reliability. Constant tension band clamps reduce leaks. Chevron Delo Extended Life Coolant (NOAT) extends maintenance intervals reducing maintenance costs. Anti-freeze effective to -30 degrees F helps protect the engine. Low coolant level sensor warns of low coolant condition to prevent engine damage. Radiator Size by Model: 579/367 FEPTO 1325 sq in, 567/365/367: 1440 sq in, 365 FEPTO: 1184 sq in, 389/367 HH: 1669 sq in, 348: 1000 sq in, 520: 1242 sq in.	0	0
3120320	O	Bugscreen	140	0
3120450	S	Stainless Steel Grille	0	0
3261980	S	Heavy Duty Air Cleaner Molded rubber air intake connections with lined stainless steel clamps seal to prevent contaminants in air intake.	0	0
3281750	O	Pre-Cleaner ECG	142	13

Price Level: April 1, 2021

Deal: SAN LUIS ASL

Printed On: 3/12/2021 8:06:03 AM

Date: March 12, 2021

Quote Number: QUO-792450-X2B2K5



Sales Code	Std/Opt	Description	\$ List	Weight
3365300	S	Exhaust Vertical LH DPF/SCR LH Back of Cab Vertical.	0	0
3381860	O	Exhaust 90 Degree Diffuser	153	0

Transmission & Equipment

4052420	O	Allison 4500 RDS-P Transmission, Gen 5 Rugged Duty Series. Includes Rear Transmission Support except on MX engines, Mobil Delvac Transmission Fluid, and Water-Oil Heat Exchange. Also includes features that monitor the transmission fluid, filter and clutch condition. Will display percent life remaining for the transmission fluid, filter and clutches on the shift selector. This information may be displayed using the Mode and Up and Down buttons. A wrench icon will also be included to indicate when the transmission fluid, filter or clutches need servicing. Suited for vehicles operating on/off highway and/or requiring PTO operation. Forward ratios: 1st-4.70, 2nd-2.21, 3rd-1.53, 4th-1.00, 5th-0.76, 6th-0.67. Reverse ratios: DR-(5.55).	17,755	390
4210200	O	1760 HD Driveline, 1 Midship Bearing	231	-15
4216590	O	1710 Driveline Interaxle For tandem rear axles	-281	-5
4252170	O	Auto Neutral Activates With Parking Brake Auto Neutral helps improve jobsite safety by reducing the possibility of the truck moving due to throttle application.	19	0
4252890	O	Allison FuelSense 2.0 Not Desired	-106	0
4252950	O	Omit Allison Neutral At Stop	0	0
4256020	S	Console Mounted Push Button Shifter Allison Automatic Transmissions or LFNA Electric Vehicle	0	0
4256740	O	Allison 6-Speed Configuration, Wide Ratio Gears Allison 4500 transmission only	0	0
4256870	O	Allison Output Function S Neutral Indicator Allison output function S Neutral Indicator for PTO. Required on Refuse Packer Applications. With this configuration NEUTRAL only, PTO engagement is permitted only when the transmission is in Neutral. Once the transmission is in Neutral, the PTO is automatically engaged and fast idle is initiated when the PTO switch is on. In addition with this configuration Pack-on-the-fly, the PTO is automatically engaged and fast idle is initiated when the PTO switch is On concurrently with shifting of the transmission to Neutral.	0	0

Air & Trailer Equipment

4510210	S	Bendix AD-HF EP Air Dryer, Heater Coalescing filter, extended purge. Bendix AD-HF air filters protects the life of your engine system and components. Proven PuraGuard oil coalescing technology in the the air dryer cartridge. This oil coalescing filter ensures the removal of oil and oil aerosols before they can contaminate the moisture removing desiccant.	0	-8
---------	---	---	---	----

Price Level: April 1, 2021

Deal: SAN LUIS ASL

Printed On: 3/12/2021 8:06:03 AM

Date: March 12, 2021

Quote Number: QUO-792450-X2B2K5



Sales Code	Std/Opt	Description	\$ List	Weight
4540420	S	Nylon Chassis Hose	0	0
4542320	O	Central Location For Air Tank Drain Valves Wire braid hose to air tanks. (Not available with optional drain valves.)	339	4
4543320	S	Steel Painted Air Tanks All air tanks are steel with painted finish except when Code 4543330 Polish Aluminum Air Tanks is also selected (then exposed air tanks outside the frame rails will be polished aluminum). Peterbilt will determine the optimal size and location of required air tanks. Narratives requesting a specific air tank size or location will not be accepted for factory installation. See ECAT to determine number or location of air tanks installed.	0	0
Tires & Wheels				
5064010	S	FF: BR 20ply 315/80R22.5 M870 Efficiency Rating: Fair Diameter= 42.8 inches; SLR= 19.9 inches The Bridgestone M870 is a high scrub All-Position Radial tire designed specifically for urban waste collection.	0	0
5169830	O	RR: BR 14 PLY 11R22.5 M760 Ecopia Efficiency Rating: Poor Diameter= 42.2 inches; SLR= 19.6 inches	208	88
5190008	S	Code-rear Tire Qty 08	0	0
5220520	O	FF: Alcoa 89U637 22.5 X 9.00 High Polish Aluminum, Ultra ONE technology that saves more than 50 lbs. versus a comparable steel wheel. Built for refuse, logging, mining and other heavy haul applications that demand a tough wheel. Each wheel offers a 10,000 lbs. load rating.	235	-110
5320410	O	RR: Alcoa 885657 22.5X8.25 High Polish Aluminum wheel severe service.	1,508	-272
5390008	S	Code-rear Rim Qty 08	0	0
Fuel Tanks				
5536130	O	23" Aluminum 80 Gallon Fuel Tank LH BOC Paddle handle filler cap with threadless filler neck. Top draw fuel plumbing reduces chance of introducing air into the fuel system during low fuel level conditions due to the central placement of fuel pickup tube. Wire braid fuel lines increase durability & reduce potential for leaks.	32	13
5604080	O	Location LH BOC 80 Gallon	0	0
5650490	S	Fuel Cooler Required with single fuel tank	0	0
5652980	S	DEF To Fuel Ratio Between 1:1 And 2:1	0	0
5655069	S	DEF Tank 520	0	0

Price Level: April 1, 2021
Deal: SAN LUIS ASL
Printed On: 3/12/2021 8:06:03 AM

Date: March 12, 2021
Quote Number: QUO-792450-X2B2K5



Sales Code	Std/ Opt	Description	\$ List	Weight
Battery Box & Bumper				
6011070	O	Aluminum Battery Box LH Frame Mtd Back-of- Fender Aluminum battery box left hand frame mounted back-of-fender. 8" Below top of frame.	576	0
6121700	S	Steel Bumper Channel Painted Includes two front tow eyes with pins	0	0
Cab & Equipment				
6501090	O	53" LCF ProBilt Cab RH Drive Use with auto-trans. Includes steel frames with aluminum and fiberglass panels, all aluminum doors, dual door stops, door locks, tinted safety glass thru-out, cab and door mounted entry grab handles, 65 degree hydraulic tilt, stainless steel grille, dual rear cab fenders, service module BOC (cab tilt pump, oil fill and dipstick, coolant fill and check, fluid fill and dipstick for auto trans), door mounted armrests, power windows, doghouse full insulation, rubber floor mats, ergonomic center control console, removable instrument panel, Driver Information Display, LED backlit gauges, adjustable side flip-down interior sunvisor, 16" steering wheel with integrated horn button, tilt/telescopic adjustable column, over-door storage, driver and passenger side cup holders, USB charging port and 12VDC charging outlet, header includes HVAC controls, rear cab corner windows, 18" bolt-on step on each side, self-canceling turn signals and Front Directional and Side Mounted Turn Signals.	1,361	0
6540020	O	Key All Units Alike Please add your 3 digit key code number in the key code field.	245	0
6541275		KEY G275	0	0
6800500	S	4.5" Rubber Flares On Cab And wheel well fenders	0	0
6914160	O	Sears C2 Plus Premium Driver Seat Enhanced for operator comfort with a 1" thicker foam cushion with flat bolsters for greater surface area coverage. Countoured metal seat and back pans add to overall ergonomic design with air lumbar supprt. Comes with quick attach seat and back cushions for ease of service and replacement.	341	0
6921720	S	Peterbilt Passenger Seat	0	0
6931120	O	Seat Belt Color Orange IPO Standard Black	10	0
6939400	O	Air Ride Driver	319	43
6939430	O	Mid Back Driver	76	0
6939460	O	Fabric Driver	42	0
6939510	S	Non-Air Ride Passenger	0	0

Price Level: April 1, 2021
 Deal: SAN LUIS ASL
 Printed On: 3/12/2021 8:06:03 AM

Date: March 12, 2021
 Quote Number: QUO-792450-X2B2K5



Sales Code	Std/Opt	Description	\$ List	Weight
6939540	S	Low Back Passenger	0	0
6939560	O	Fabric Passenger	42	0
7000000	S	Gray Interior Color Includes ABS gray headliner & rear cab panel, gray vinyl engine tunnel cover. For LH, RH, and dual steer dual seated power windows are standard on both doors. For dual steer RH stand-up the LH window is power and the RH window is a manual sliding window.	0	0
7001520	S	Adjustable Steering Column - Tilt/Telescope	0	0
7001620	S	Steering Wheel With Peterbilt Logo Steering Wheel with embossed Peterbilt logo over horn button.	0	0
7040020	O	Diamond Plate Floor Covering on Driver side floor in place of Rubber Mat. In Dual Steer application RH Diamond Plate covering is standard. Single drive applications the Diamond Plate is optional.	46	6
7110680	S	Exterior Cab Entry Grabhandle Textured; NFPA compliant. Available on Day Cab specifications only.	0	0
7220150	O	Rear Window Back of Cab Dark Tint 18.5in X 54in	24	0
7230350	S	2-Piece Flat Windshield	0	0
7322010	S	Combo Fresh Air Heater/Air Conditioner With radiator mounted condenser, dedicated side window defrosters, Bi-Level Heater/Defroster Controls, 54,500 BTU/HR, and silicone heater hoses.	0	0
7410040	O	Outside Sunvisor - Stainless Steel Not available with 2.1M high roof sleeper.	366	4
7560100	O	Mirrors SSTL Each Side Heated and Motorized with Switch on Door.	-30	-7
7561400	O	Look Down Mirror Mounted Front Of Cab Opposite side of the driver position. Stainless steel.	68	0
7561450	O	(4) Convex 8 Inch SSTL Mirrors; (2) Center These optional convex mirrors provide enhanced rearward visibility by allowing the driver to see the operation of front-end loader arms or other obstacles that may interfere with operation in refuse services. The mirrors have an off-center mounting that maximizes adjustability for field of view. Dual door stops are included with these mirrors for added protection to the mirrors during cab entry and exit. Includes 4 convexed 8" stainless steel mirrors and 2 center mounted under (heated) and 2 center mounted over mirror bracket (non-heated). Includes dual door stops.	118	4
7610470	O	(1) Air Horn 24.5" Chrome - Round w/Horn Shield	66	0
7722120	O	ConcertClass, AM/FM, Weatherband, 3.5 Aux	422	10
7725740	O	Midlevel Speaker Package For Cab	135	6

Price Level: April 1, 2021
Deal: SAN LUIS ASL
Printed On: 3/12/2021 8:06:03 AM

Date: March 12, 2021
Quote Number: QUO-792450-X2B2K5



Sales Code	Std/ Opt	Description	\$ List	Weight
		(4) Speakers		
7728030	O	Radio Mute When Automatic Or Automated Transmission in reverse.	0	0
7728040	O	Bluetooth Phone and Audio	62	0
7728050	O	USB Port	62	0
7788055	S	SmartLINQ Remote Diagnostics SmartLINQ is Peterbilts proprietary remote diagnostics service which monitors the engine and aftertreatment for diagnostic codes providing real-time code analysis maximizing vehicle uptime and strengthening the fleets partnership with their dealer. SmartLINQ provides fault coverage for over 800 codes, a customizable email notification for 116 codes plus a web portal to manage your entire fleet included at no additional charge. SmartLINQ is compatible with any telematics system and doesnt require a specific fleet management system. For those whose customers utilize PeopleNet, the pre-wire with remote diagnostics will provide a more integrated solution utilizing the existing SmartLINQ modem. For those whose customers utilize other fleet services products, the existing pre-wire option for the other fleet service devices will continue to be available. Standard on Class 8 engines and available on Models 348, 337, 330 and 325 with a PX-9, PX-7 or Cummins Westport natural gas engine.	0	0
7788057	O	24 Months SmartLINQ Subscription PACCAR PX Engines.	0	0
7851330	O	Cab Tilt Pump Air Assist	512	0
7851870	O	Rain Gutters Over Driver and Passenger Doors	76	8
7852150	S	Peterbilt Pantograph Windshield Wipers With intermittent feature.	0	0
7900090	O	Triangle Reflector Kit, Ship Loose Florescent triangle emergency road flares are designed to meet and exceed all DOT standards.	20	13
7900270	O	Fire Extinguisher, Cab Mounted Hazmat approved UL listed/rated ABC	75	12
7901130	O	Backup Alarm (107 DB)	110	3
8011400	O	Main Transmission Oil Temperature Gauge Located in Driver Information Display	0	0
8011800	O	Drive Axle #1 Front Oil Temperature Gauge Located in Digital Cluster Display.	0	0
8011810	O	Drive Axle #2 Rear Oil Temperature Gauge Located in Digital Cluster Display.	0	0
8011830	O	Engine Oil Temperature Located in Digital Cluster Display.	0	0
8011850	S	Transmission Oil Temperature (Main) Located in Digital Cluster Display.	0	0
8021015	O	Air Application Gauge	0	0

Price Level: April 1, 2021

Deal: SAN LUIS ASL

Printed On: 3/12/2021 8:06:03 AM

Date: March 12, 2021

Quote Number: QUO-792450-X2B2K5



Sales Code	Std/ Opt	Description	\$ List	Weight
		Located in Driver Information Display		
8021315	S	Air Restriction Indicator Mounted on exhaust stanchion	0	0
8021800	O	Air Filter Restriction Pressure Gauge Located in Digital Cluster Display	0	0
8031120	O	Warning Light Battery Disconnect, Switch Engaged Marker light external mounted	14	0
8070260	O	Switch To Deactivate ATC Traction Control Bendix ATC is required on the specification. Switch is to temporarily disable the Traction Control in extreme conditions such as snow, ice or mud. The ATC warning light will display in a constant state.	0	0
8070390	O	Engine Hourmeter Gauge Located in Digital Cluster Display	0	0
8070450	O	Engine PTO Hourmeter Gauge Located in digital cluster display	0	0
8070810	O	Engine Manifold Pressure (Turbo Boost) Located in Digital Cluster Display	0	0
8070820	O	Engine Percent Torque Located in Digital Cluster Display	0	0
8070860	O	Main Instrumentation Panel Digital Cluster 7" Display includes: Physical (Analog) - Speedometer, Tachometer, Oil Pressure, Coolant Temp and Display Gauges - Fuel Level, DEF Level, DPF Filter Status, Fuel Economy, Volts Telltale, OAT and Primary Air Pressure, Secondary Air Pressure for air brake trucks.	0	0
8070940	O	Voltmeter Gauge (MD / 520 ONLY) Located in Digital Cluster Display	0	0
8071025	O	Manifold Pressure Gauge Located in Driver Information Display	0	0
8110090	S	Headlights Single Rectangular Halogen	0	0
8120570	S	(5) LED Clearance With (2) LED Marker Lights Includes (5) lights mounted on roof of cab and (1) cab side marker light mounted in front of each cab door	0	0
8133960	O	Daytime Running Lights The brake interlock turns the daytime running lights off when the parking brakes are engaged. This is required on all Canadian vehicles.	61	0
8134160	O	Self-Canceling Turn Signal	0	0
Paint				
8500710	S	Standard Paint Color Selection	-200	0
8530770	O	(1) Color Axalta Two Stage - Cab/Hood Base Coat/Clear Coat N85020 A- L0006EY WHITE N85700 BUMPER L0001EA BLACK N85500 CAB ROOF L0006EY WHITE N85200 FRAME L0001EA BLACK	0	0

Price Level: April 1, 2021

Deal: SAN LUIS ASL

Printed On: 3/12/2021 8:06:03 AM

Date: March 12, 2021

Quote Number: QUO-792450-X2B2K5



Sales Code	Std/ Opt	Description	\$ List	Weight
Shipping Destination				
Options Not Subject To Discount				
9400090	S	Peterbilt Class 8 Standard Coverage 1 year/100,000 Miles (160,000 km)	0	0
9400094	S	PACCAR PX-9 Standard Coverage 2 yrs/250,000 mi (402,336 km)/6,250 hrs	0	0
9402053	O	Chassis to Receive Extended Warranty 1 Year Base Vehicle Towing - US. No Additional Extended Warranty is Required.	150	0
9408982	O	Vehicle Layout Option is not subject to discount. Fleets will be split prior to build so that the charge is applied to only one unit. Quotes will not reflect this.	1,350	0
Miscellaneous				
9409831	S	2021 EPA Emissions Engine Warranty Only	0	0

Promotions

Order Comments



Total List Price (W/O Freight & Warranty & Surcharges)	\$232,706
Marketing and Service Support Fee	\$875
Prepaid Freight	\$3,225
Total Surcharge/Options Not Subject To Discount	\$1,500
Total Weight	16,255

Prices and Specifications Subject to Change Without Notice.

Unpublished options may require review/approval.
Dimensional and performance data for unpublished options may vary from that displayed in CRM.

PRICING DISCLAIMER

While we make every effort to maintain the web site to preserve pricing accuracy, prices are subject to change without notice. Although the information in this price list is presented in good faith and believed to be correct at the time of printing, we make no representations or warranties as to the completeness or accuracy of this information. We reserve the right to change, delete or otherwise modify the pricing information which is represented herein without any prior notice. We carefully check pricing specifications, but occasionally errors can occur, therefore we reserve the right to change such prices without notice. We disclaim all liability for any errors or omissions in the materials. In no event will we be responsible for any damages of any nature whatsoever from the reliance upon information from these materials. Please check your order prebills to confirm your pricing information



Shipping Destinations

Intermediate Destination: none

Final Destinations	Quantity
--------------------	----------

HORIZONTAL DIMENSIONS

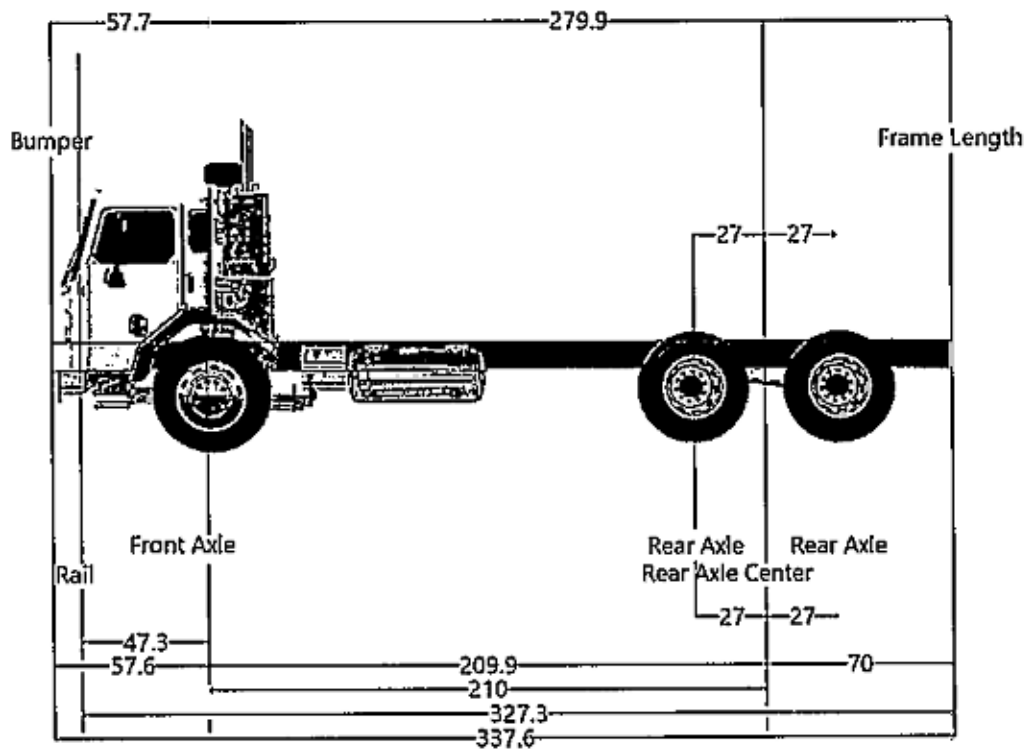

Dimension	Measurement	Start	End
Axle Spacing	54	183	237
Bumper to Back of Cab	57.7	-57.6	0.1
Bumper to Front Axle	57.6	-57.6	0
Bumper to Front Frame	10.3	-57.6	-47.3
Cab to End of Frame	279.9	0.1	280
Cab to End of Frame/Loadspace	CAB TO END OF FRAME EQUALS LOADSPACE ON THIS CONFIGURATION.		
Cab to Rear Axle	209.9	0.1	210
Effective Bumper to Back Of Cab	57.7	-57.6	0.1
Frame Length	327.3	-47.3	280
Front Axle to Back of Cab	0.1	0	0.1
Front of Frame to Axle	47.3	-47.3	0
Load Space	279.9	0.1	280
Overall Length	337.6	-57.6	280
Overhang	70	210	280
Pusher Offset #1	0	183	210
Pusher Offset #2	0	183	210
Pusher Offset #3	0	183	210
Tag Offset	0	210	237
Wheelbase	210	0	210



AGENDA ITEM REVIEW FORM

Regular City Council Meeting

5. B.

Meeting Date: 07/14/2021

Department Head: Kay Macuil, City Attorney, Attorney's Office

Submitted By: Kay Macuil, City Attorney, Attorney's Office

Action Requested: Motion
Resolution

ITEM:

Discussion and possible action on any and all matters regarding Resolution No. 2188. A resolution of the Mayor and City Council of the City of San Luis, Arizona amending section HR-4-03(A) of the City of San Luis Personnel Policies relating to holidays, adding Miguel Gonzalez Day in memory of our esteemed colleague lost due to the COVID-19 pandemic and in commemoration of the perseverance of the essential workers and first responders in continuing the services to the City of San Luis throughout the difficulties presented by the public health emergency. **(Mayor Gerardo Sanchez and Vice Mayor Africa Luna-Carrasco)**

SUMMARY:

The remembrance and commemoration day described in this item is to be observed annually by the Municipality of San Luis on the last Monday of October.

RECOMMENDATION / SUGGESTED MOTION:

I MOVE TO APPROVE RESOLUTION NO. 2188.

Fiscal Impact

IS THERE FISCAL IMPACT ASSOCIATED WITH THIS ITEM: No

CITY/STATE/FEDERAL FUNDS: N/A

TOTAL: N/A

BUDGETED AMOUNT: N/A

AVAILABLE AMOUNT TO TRANSFER: N/A

ACCT NAME & GL#/REMAINING BALANCE BEFORE PURCHASE: N/A

FISCAL IMPACT STATEMENT (IF THIS IS A BUDGET TRANSFER, YOU MUST ATTACH THE BUDGET ADJUSTMENT FORM):

There is no discernable fiscal impact associated with this item.

Attachments

Resolution No. 2179



Resolution

No. 2179

OFFICE OF THE
MAYOR
CITY OF SAN LUIS

A RESOLUTION OF THE MAYOR AND CITY COUNCIL OF THE CITY OF SAN LUIS, ARIZONA AMENDING SECTION HR-4-03(A) OF THE CITY OF SAN LUIS PERSONNEL POLICIES RELATING TO HOLIDAYS, ADDING A REMEMBRANCE DAY TO COMMEMORATE THE COVID-19 PANDEMIC.

WHEREAS, the last Monday in October would be an appropriate day of remembrance and to commemorate the historic COVID-19 pandemic; and

WHEREAS, in 2020, COVID-19 exponentially spread throughout the world; and

WHEREAS, the COVID-19 pandemic has had a disastrous impact on human life, the economy and the local San Luis community; and

WHEREAS, the impacts will continue as people mourn the loss of loved ones and survivors of the disease suffer long-term health effects; and

WHEREAS, public servants, frontline workers, essential workers, and first responders selflessly and tirelessly continued throughout the COVID-19 pandemic even when there were no treatments or vaccines to find ways to keep serving the community; and

WHEREAS, the City of San Luis took measures to prevent the spread of the disease by promoting mask-wearing and organizing vaccination events; and

WHEREAS, the lives lost and the sacrifices made shall be remembered; and

NOW, THEREFORE, BE IT RESOLVED by the Mayor and Council of the City of San Luis, State of Arizona as a demonstration of their appreciation of the perseverance of the employees of the City of San Luis through the COVID-19 pandemic:

Section 1. Section HR-4-03(A) of the City of San Luis Personnel Policies is deleted and replaced as follows:

HR-4-03 Holidays.

A. City service holidays. Holidays shall be observed on the day they occur unless the Holiday falls on a Saturday, at which time the Holiday will be observed the Friday preceding it, and if the Holiday falls on a Sunday, it will be observed the following Monday. The City observes 12 holidays as follows:

1.	January 1 st	"New Year's Day"
2.	3 rd Monday in January	"Martin Luther King, Jr. / Civil Rights Day"
3.	3 rd Monday in February	"Lincoln-Washington / Presidents' Day"
4.	March 31 st	"César Chávez Day"
5.	Last Monday in May	"Memorial Day"
6.	July 4 th	"Independence Day"
7.	1 st Monday in September	"Labor Day"
8.	2 nd Monday in October	"Columbus Day"
9.	Last Monday in October	"COVID-19 Remembrance Day"
10.	November 11th	"Veterans' Day"
11.	4 th Thursday in November	"Thanksgiving Day"
12.	December 25th	"Christmas Day"

PASSED, APPROVED and ADOPTED by the Mayor and City Council of the City of San Luis, Yuma County, Arizona, this ____ day of May 2021.

Gerardo Sanchez, Mayor

ATTEST:

APPROVED AS TO FORM:

Sonia Cornelio, City Clerk

Kay Marion Macuil, City Attorney