



NOTICE OF REGULAR COUNCIL MEETING

In accordance with § 38-431.02 of the Arizona Revised Statutes of the State of Arizona, notice is hereby given to the Members of City Council and to the general public that the Mayor and Council of the City of San Luis, Arizona will hold a Regular City Council meeting at 6:00 p.m., Wednesday, April 10, 2024. The meeting will take place at the City Council Chambers, located at 1090 E. Union Street, San Luis, Arizona, 85349. The public is invited to attend the open meeting.

In accordance with the Americans with Disabilities Act (ADA) and Section 504 of the Rehabilitation Act of 1973, the City of San Luis does not discriminate on the basis of disability in the admission of or access to, or treatment or employment in its programs, activities, or services. For information regarding rights and provisions of the ADA or Section 504, or to request reasonable accommodations for participation in City programs, activities, or services contact: ADA/Section 504 Coordinator, City of San Luis Human Resources Department, 1090 E. Union Street, San Luis, Arizona, 85349; (928) 341-8520.

Notice is hereby given that pursuant to A.R.S. § 1-602.A.9, subject to certain specified statutory exceptions, parents have a right to consent before the State or any of its political subdivisions make a video or audio recording of a minor child. Meetings of the City Council are audio and/or video recorded, and, as a result, proceedings in which children are present may be subject to such recordings. Parents in order to exercise their rights may either file written consent with the City Clerk to such recordings or take personal action to ensure that their child or children are not present when a recording may be made. If a child is present at the time a recording is made, the City will assume that the rights afforded parents pursuant to A.R.S. § 1-602.A.9 have been waived.

THIS NOTICE IS GIVEN BY:

/s/ Sonia Cornelio, City Clerk

AVISO DE JUNTA REGULAR

De acuerdo con los Estatutos del Estado de Arizona A.R.S. § 38-431.02, se le informa a los miembros del Cabildo y al público en general que el Alcalde y el Cabildo, tendrán una Junta Regular a las 6:00 p.m., el día Miércoles, 10 de Abril del 2024. La junta se llevará a cabo en la Sala del Cabildo, ubicada en el 1090 E. Union Street, San Luis, Arizona, 85349. El público está invitado a la junta.

De acuerdo con el Acta de Americanos con Discapacidades y la Sección 504 del Acta de Rehabilitación del 1973, la Ciudad de San Luis, Arizona no discrimina por causa de discapacidad la admisión y acceso a sus programas, actividades, servicios o en el trato en cuanto a empleo. Para más información referente a derechos y provisiones del Acta de Americanos con Discapacidades o Sección 504, o para solicitar adaptaciones que sean razonables para la participación en programas, actividades o servicios de la Ciudad, contactar al: Coordinador del Acta de Americanos con Discapacidades/Sección 504, Departamento de Recursos Humanos de la Ciudad de San Luis, Arizona, ubicado en el 1090 E. Union Street, San Luis, Arizona, 85349; (928) 341-8520.

Por medio de este aviso y de acuerdo con los Estatutos del Estado de Arizona A.R.S § 1-602.A.9, sujeto a ciertas excepciones reglamentarias, los padres de familia tienen el derecho de dar el consentimiento ante el Estado o cualquiera de sus subdivisiones políticas para hacer una grabación de audio o video de su hijo menor de edad. Las juntas del Cabildo se graban en audio y/o video y como resultado, el hecho de que haya menores presentes puede ser sujeto a que sean grabados. Para que los padres de familia puedan ejercer sus derechos pueden dar el consentimiento por escrito con la Secretaria de la Ciudad a tal grabación, o tomar acción personal para asegurarse que su hijo menor no esté presente cuando la grabación se lleve a cabo. Si un menor de edad está presente en el momento de la grabación, la Ciudad asumirá que los padres de familia están cediendo los derechos sobre una posible grabación de acuerdo con los Estatutos del Estado de Arizona A.R.S. § 1-602.A.9.

ESTE AVISO ES DADO POR:

/f/ Sonia Cornelio, Actuaría de la Ciudad

**AMENDED AGENDA ON 4/8/2024
PREVIOUSLY ITEM NO. 11 .B. HAS BEEN REMOVED AND
RE-NUMBERED ACCORDINGLY**



**AGENDA
Regular Meeting
San Luis City Council
Council Chambers
1090 E. Union Street
San Luis, AZ 85349
April 10, 2024
6:00 p.m.**

PLEASE TAKE NOTICE THAT MEMBERS OF THE CITY COUNCIL WILL ATTEND EITHER IN PERSON, TELEPHONE, OR VIDEO CONFERENCE COMMUNICATION. THE MAYOR OR ACTING MAYOR FOR THIS MEETING MAY CHANGE THE ORDER OF THE ITEMS; IF AUTHORIZED BY LAW AND BY A MAJORITY VOTE OF A QUORUM OF CITY COUNCIL MEMBERS PRESENT, AN EXECUTIVE SESSION WILL BE HELD IMMEDIATELY FOLLOWING THE VOTE IN ACCORDANCE WITH A.R.S. § 38-431.03(A) AND THE MEETING WILL BE TEMPORARILY RECESSED WHILE THE CITY COUNCIL RETIRES TO EXECUTIVE SESSION WHICH WILL NOT BE OPEN TO THE PUBLIC.

TENGA EN CUENTA QUE LOS MIEMBROS DEL CABILDO DE LA CIUDAD ASISTIRÁN EN PERSONA, TELÉFONO O COMUNICACIÓN POR VIDEO CONFERENCIA. LA ALCALDESA O ALCALDE INTERINO DE ESTA REUNIÓN PUEDE CAMBIAR EL ORDEN DE LOS TEMAS; SI ESTÁ AUTORIZADO POR LA LEY Y POR MAYORÍA DE VOTOS DE UN QUÓRUM DE MIEMBROS DEL CABILDO PRESENTES, SE LLEVARÁ A CABO UNA SESIÓN EJECUTIVA INMEDIATAMENTE DESPUÉS DE LA VOTACIÓN DE ACUERDO CON LOS ESTATUTOS DEL ESTADO DE ARIZONA A.R.S. § 38-431.03 (A) Y LA REUNIÓN SERÁ TEMPORALMENTE RECESADA MIENTRAS EL CABILDO DE LA CIUDAD SE RETIRE A UNA SESIÓN EJECUTIVA QUE NO ESTARÁ ABIERTA AL PÚBLICO.

1. CALL TO ORDER/ROLL CALL

2. PLEDGE OF ALLEGIANCE

3. INVOCATION

4. CALL TO THE PUBLIC

This is the time for the public to comment. Members of the City Council may not discuss items that are not specifically identified on the agenda. Therefore, pursuant to A.R.S. § 38-431.01 (H), action taken as a result of public comment will be limited to directing staff to study the matter, responding to any criticism or scheduling the matter for further consideration and decision at a later date.

5. PROCLAMATIONS

5. A. Proclamation - National Public Safety Telecommunicators Week April 14-20, 2024

5. B. Proclamation - Power Talk 21 Day April 21, 2024

5. C. Proclamation - Administrative Professionals Day April 24, 2024 and Week April 21-27, 2024

5. D. Proclamation - Denim Day April 24, 2024

- 6. CONSENT AGENDA**
All matters are considered to be routine by the City Council and will be enacted by one motion. If discussion is desired, that item will be removed from the Consent Agenda and will be considered separately.
- 6. A. MINUTES OF**
- Regular Council meeting held March 13, 2024
- 6. B. DISBURSEMENTS FROM MARCH 20, 2024 TO APRIL 3, 2024**
Total \$1,290,607.27
(One Million, Two Hundred Ninety Thousand, Six Hundred Seven Dollars and Cents)
- 7. DISCUSSION AND POSSIBLE ACTION ITEMS:**
- 7. A.** Discussion and possible action on any and all matters regarding the appointment of poll workers for the Special Election scheduled for May 21, 2024. **(Sonia Cornelio, City Clerk)**
- 7. B.** Discussion and possible action on any and all matters regarding the acceptance and award of a construction contract to DWD Construction for the Finance Wing Reconfiguration Project at City Hall. **(Edgar Juarez, Facilities Project Coordinator)**
- 7. C.** Discussion and possible action on any and all matters regarding the acceptance and award of a construction contract to Yuma Valley Contractors, Inc. for the construction of a new concrete two million gallon water storage tank at well site seven. **(Jorge Perez, Assistant Director of Public Works)**
- 7. D.** Public hearing followed by discussion and possible action on any and all matters regarding Conditional Use Permit Case No. 2024-0039 - Colibri Self Storage; a request by Riedel Holdings LLC, owner, for a Conditional Use Permit from Section 18.35.030 (C)(10) of the City of San Luis Zoning Ordinance to allow a mini storage, located at 4834 E County 24th Street in San Luis, Arizona. **(Jose A. Guzman, Director of Development Services)**
- A. Open Public Hearing
1. Presentation by staff and/or applicant
2. Call to the Public on this item
- B. Close Public Hearing
- C. Action on Conditional Use Permit Case No. 2024-0039
- 7. E.** Public hearing followed by discussion and possible action on any and all matters regarding Conditional Use Permit Case No. 2024-0040 - Rio Colorado Fueling Systems Fuel Station; a request by Core Engineering Group, on behalf of RL Jones Properties LLC, for a Conditional Use Permit from Section 18.40.20 (C)(1) and (10) of the City of San Luis Zoning Ordinance to allow a truck stop with a gas station and convenience store, located on the southwest corner of Vaughan Street and Port Authority Avenue in San Luis, Arizona. **(Jose A. Guzman, Director of Development Services)**
- A. Open Public Hearing

1. Presentation by staff and/or applicant
 2. Call to the Public on this item
- B. Close Public Hearing
C. Action on Conditional Use Permit Case No. 2024-0040

7. **F.** Discussion and possible action on any and all matters regarding Subdivision Case No. 2024-0047F - Bienestar Estates 10 Townhomes; a request by Vega & Vega, on behalf of Comite de Bienestar, Inc., for the approval of the final plat for Bienestar Estates 10 Townhome Subdivision, located at the southeast corner of Avenue F and County 24th Street in San Luis, Arizona. **(Jose A. Guzman, Director of Development Services)**

8. **BOARD OF ADJUSTMENT
MOTION TO ADJOURN AS CITY COUNCIL AND CONVENE AS BOARD OF
ADJUSTMENT**

8. **A.** Public hearing followed by discussion and possible action on any and all matters regarding Variance Case No. 2024-0086 - First Days Care; a request by Innov-R, on behalf of GPG Estates and Associates, for a variance from the City of San Luis Zoning Ordinance Section 18.75.040 - Table No. 15 to reduce the parking required from 4 to 2 and a variance from the City of San Luis Zoning Ordinance Section 18.35.040 - Table No. 7 to reduce the minimum setback from 15 feet to 10 feet in a Neighborhood Commercial (C-1), located at 648 N 4th Avenue in San Luis, Arizona. **(Jose A. Guzman, Director of Development Services)**

- A. Open Public Hearing
1. Presentation by staff and/or applicant
 2. Call to the Public on this item
- B. Close Public Hearing
C. Action on Variance Case No. 2024-0086

9. **MOTION TO ADJOURN AS BOARD OF ADJUSTMENT AND CONVENE AS CITY
COUNCIL.**

10. **SUMMARY OF CURRENT EVENTS**

Events by Mayor, Council Members and/or City Manager pursuant to A.R.S. § 38-431.02 (K).

11. Discussion and possible action to hold an Executive Session pursuant to A.R.S. §§ 38-431.03(A)(3), (4), and (7) on any and all matters regarding the lawsuit Gethsemani Food Ministry v. City of San Luis for consultation for legal advice with the city attorneys including but not limited to possible directions including contract negotiations (under subsection (4)) or land lease (under subsection (7)) allowed in executive sessions. **(Kay Marion Macuil, City Attorney, Outside Counsel Cameron Artigue and Manjula Vaz or Gammage and Burnham)**

12. **MOTION TO GO BACK INTO REGULAR SESSION**

13. DISCUSSION AND POSSIBLE ACTION ITEM:

Discussion and possible action on any and all matters regarding the approval and ratification to engage outside counsel for the lawsuit U.S. District Court for Arizona, Civil Case No. 2:24-cv-00534-ESW. **(City Council and Kay Marion Macuil, City Attorney)**

14. ADJOURNMENT



PROCLAMATION

Regular City Council Meeting

5. A.

Meeting Date: 04/10/2024

Title:

Proclamation - National Public Safety Telecommunicators Week April 14-20, 2024

Attachments

Proclamation



Proclamation

OFFICE OF THE
MAYOR
CITY OF SAN LUIS

NATIONAL PUBLIC SAFETY TELECOMMUNICATORS WEEK April 14 - 20, 2024

WHEREAS, emergencies can occur at any time that requires police, fire, or emergency medical services; and

WHEREAS, when an emergency occurs, the prompt response of police officers, firefighters, and paramedics is critical to the protection of life and preservation of property; and

WHEREAS, the safety of our police officers and firefighters is dependent upon the quality and accuracy of information obtained from citizens who telephone the City of San Luis Police Department communications center; and

WHEREAS, Public Safety Telecommunicators are the first and most critical contact our citizens have with emergency services; and

WHEREAS, Public Safety Telecommunicators are the single vital link for our police officers and firefighters by monitoring their activities by radio, providing them information and ensuring their safety; and

WHEREAS, Public Safety Telecommunicators of the City of San Luis Police Department have contributed substantially to the apprehension of criminals, suppression of fires, and treatment of patients; and

WHEREAS, each dispatcher has exhibited compassion, understanding, and professionalism during their job performance in the past year.

NOW, THEREFORE, BE IT RESOLVED, that I, Nieves Riedel, Mayor of the City of San Luis, do hereby proclaim the week of April 14 - 20, 2024, as "**National Public-Safety Telecommunicators Week**" in San Luis, in honor of the men and women whose diligence and professionalism keep our city and citizens safe.

DATED, this 10th day of April 2024.

Nieves Riedel, Mayor

ATTEST:

Sonia Cornelio, City Clerk



PROCLAMATION

Regular City Council Meeting

5. B.

Meeting Date: 04/10/2024

Title:

Proclamation - Power Talk 21 Day April 21, 2024

Attachments

Proclamation



Proclamation

OFFICE OF THE
MAYOR
CITY OF SAN LUIS

**POWERTALK 21 DAY
April 21, 2024**

WHEREAS, the City of San Luis, Arizona, recognizes the importance of parents talking with their teens about alcohol in order to reduce the risks and dangers posed to teen and communities; and

WHEREAS, high school students who use alcohol or other substances are five times more likely to drop out of school or believe good grades are not important; and

WHEREAS, 23% of middle school students try alcohol before graduating from 8th grade, significantly increasing the risk that they will develop alcohol problems later in life; and

WHEREAS, teen alcohol use kills 6,000 people each year, more than all other illegal drugs combined; and

WHEREAS, the majority of kids say their parents are their primary influence when it comes to decisions about drinking alcohol; and

WHEREAS, PowerTalk 21 Day, started by Mothers Against Drunk Driving (MADD) in 2011, is established on April 21, 2015, to encourage parents and caregivers to embrace their important role in influencing America's youth and their decisions about drinking alcohol; and

WHEREAS, in 2023, MAAD encourages parents to use PowerTalk 21, as part of the power of Parents Program to create a sustained and prolonged conversations about underage drinking and other drugs among middle school and high school students; and

WHEREAS, to equip parents to talk with their teens about alcohol, MADD Arizona invites all parents to go to www.madd.org/the-solution/power-of-parents for a free download of the Power of Parents handbooks giving parents the tools to effectively talk to their children about alcohol and other drugs to protect them; and

WHEREAS, I urge all citizens to join in the local and national efforts to raise awareness of the importance of parents and teen talking together about alcohol to reduce the risks and dangers posed to teens and communities; and

NOW, THEREFORE, BE IT RESOLVED, that, I, Nieves Riedel, Mayor of the City of San Luis, do hereby proclaim April 21st, 2024, as “**PowerTalk 21 Day**”, in the City of San Luis, Arizona.

DATED this 10th day of April 2024.

Nieves Riedel, Mayor

ATTEST:

Sonia Cornelio, City Clerk



PROCLAMATION

Regular City Council Meeting

5. C.

Meeting Date: 04/10/2024

Title:

Proclamation - Administrative Professionals Day April 24, 2024 and Week April 21-27, 2024

Attachments

Proclamation



OFFICE OF THE
MAYOR
CITY OF SAN LUIS

Proclamation

ADMINISTRATIVE PROFESSIONALS DAY
April 24, 2024; and
ADMINISTRATIVE PROFESSIONALS WEEK
April 21 to 27, 2024

WHEREAS, Administrative professionals play an essential role in coordinating the office operations of businesses, government, educational institutions and other organizations; and

WHEREAS, the work of administrative professionals today requires advanced knowledge and expertise in communications, computer software, office technology, project management, organization, customer service and other vital office management responsibilities; and

WHEREAS, Administrative Professionals Day is observed annually in workplaces around the world to recognize the important contributions of administrative support staff and is sponsored by the International Association of Administrative Professionals; and

WHEREAS, Administrative Professionals Week 2024 is focused on “honoring the office professionals who make offices work,” reflecting the integral and central role that office professionals play in modern business; and

NOW, THEREFORE, BE IT RESOLVED, that I, Nieves Riedel, Mayor of the City of San Luis, hereby proclaim April 24, 2024, as “**Administrative Professionals Day**” and the week of April 21 to April 27, 2024, as “**Administrative Professionals Week**”, saluting the valuable contributions of administrative professionals in the workplace. I call on all employers to support continued training and development for administrative staff, recognizing that a well-trained workforce is essential for success in today’s business world.

DATED this 10th day of April 2024.

Nieves Riedel, Mayor

ATTEST:

Sonia Cornelio, City Clerk



PROCLAMATION

Regular City Council Meeting

5. D.

Meeting Date: 04/10/2024

Title:

Proclamation - Denim Day April 24, 2024

Attachments

Proclamation



Proclamation

OFFICE OF THE
MAYOR
CITY OF SAN LUIS

DENIM DAY
April 24, 2024

WHEREAS, since 1999, Peace Over Violence has run an inspiring and powerful opportunity to practice solidarity and support survivors by renewing our commitment to exposing harmful behaviors and attitudes surrounding sexual violence; and

WHEREAS, Denim Day is a campaign on a Wednesday in April in honor of Sexual Assault Awareness Month; and

WHEREAS, what started as a local campaign to bring awareness to victim blaming and destructive myths that surround sexual violence has grown into a movement; and

WHEREAS, the campaign began after a ruling by the Italian Supreme Court where a rape conviction was overturned because the justices felt that since the victim was wearing tight jeans she must have helped the person who raped her remove her jeans, thereby implying consent; and

WHEREAS, as the longest running sexual violence prevention and education campaign in history, Denim Day asks community members, elected officials, businesses and students to make a social statement with their fashion statement by wearing jeans on this day as a visible means of protest against the misconceptions that surround sexual violence.

NOW, THEREFORE, BE IT RESOLVED, that I, Nieves Riedel, Mayor of the City of San Luis, do hereby proclaim April 24, 2024, as “**Denim Day**” and I further call upon the citizens of San Luis to show their support in ending sexual violence through the efforts of all of us.

DATED this 10th day of April 2024.

Nieves Riedel, Mayor

ATTEST:

Sonia Cornelio, City Clerk



AGENDA ITEM REVIEW FORM

Regular City Council Meeting

6. A.

Meeting Date: 04/10/2024

Summary

MINUTES OF

- Regular Council meeting held March 13, 2024

Attachments

Minutes 3/13/2024 RCM

MINUTES
Regular Council Meeting
San Luis City Council
San Luis Council Chambers
1090 E. Union Street
March 13, 2024
6:00 p.m.

1. CALL TO ORDER/ROLL CALL

Mayor Nieves Riedel called the Regular City Council meeting to order at approximately 6:00 p.m.

PRESENT: Mayor Nieves Riedel
Council Member Maria Cecilia Cruz
Council Member Matias Rosales
Council Member Javier Vargas
Council Member Tadeo Azael De La Hoya

ABSENT: Vice Mayor Gloria Torres
Council Member Luis E. Cabrera

OTHERS PRESENT: Jenny Torres, Acting City Manager
Kay Macuil, City Attorney
Sonia Cornelio, City Clerk
Adela Cortez, Director of Human Resources
Angel Ramirez, Fire Chief
Angelica Roldan, Director of Parks & Recreation
Antonio Maldonado, Video Production Specialist
Armando Esparza, Director of Economic Development
Edgar Esparza, Billing & Collections Manager
Fernando Corona, Acting I.T. Manager
Francia Alonso, Public Information Officer
Joel Armendariz, I.T. Help Desk Technician
Jose Guzman, Director of Development Services
Lizette Varela, Assistant Director of Parks & Recreation
Maria Sabori, Risk Manager
Miguel Ramirez, Finance Accounting Manager
Nigel Reynoso, Chief of Police
Olivia Jenkins, Operations Coordinator
Roula Encinas, Acting Director of Finance
Ruben Lopez, I.T. Technician
Cristian Cuevas, Simultaneous Translator
Alberto Leon, Resident
Emanuel Reyes, Resident
Najeh Edais, Edais Engineering
Manuel Rojas, Resident
Mark Concha, Resident

Monica Villalobos, Arizona Chamber of Commerce

2. PLEDGE OF ALLEGIANCE

Council Member Maria Cecilia Cruz, led the Pledge of Allegiance.

3. INVOCATION

Pastor Abel Garcia – Church for the City, led the invocation.

4. CALL TO THE PUBLIC

Mr. Nigel Reynoso, Chief of Police, invited the public, community members and other departments for a series of Community Forums that will be held throughout the City of San Luis. For the month of March, the Community Forums will start in the area of Avenue F and Avenue E. March 21, 2024, it will be at Sandoval Park located at Janet Napolitano Boulevard at 6:00 p.m. and March 25, 2024 at Alegria Park, located at 3571 Udall Lane at 6:00 p.m. Police Department Community Forums are for questions, concerns, feedback, and starting a Neighborhood Watch Program.

5. PROCLAMATION/PRESENTATION

5. A. Proclamation – Women’s History Month March 2024

Mrs. Sonia Cornelio, City Clerk, read the proclamation by title only.

5. B. Presentation on the Hispanic Chamber of Commerce DATOS program by Bonsal Glascock, Chair of the Mexico Committee. (Jenny Torres, Acting City Manager)

Ms. Jenny Torres, Acting City Manager, introduced Mr. Bonsal Glascock.

Mr. Glascock thanked the Mayor and City Council for allowing the Arizona Hispanic Chamber to present to them in a manner of education and collaboration between the city and the Arizona Hispanic Chamber. He introduced Ms. Monica Villalobos, Executive Director and CEO of the Arizona Hispanic Chamber of Commerce.

Ms. Villalobos provided a PowerPoint presentation sharing information and the positive impact Latinos have in the state of Arizona, county and economy. She added that the Arizona Hispanic Chamber has been in existence for 75 years. Her presentation included topics regarding key initiatives and impact areas, and economic opportunity.

Mr. Paul Padilla, Arizona Hispanic Chamber, explained the data at the state relationship and trade relationship between Mexico and Arizona. He added that Mexico is a top trading partner for Arizona on the export and import aspects.

Mayor Nieves Riedel thanked the Arizona Hispanic Chamber for the presentation and information provided.

6. CONSENT AGENDA

6. A. MINUTES OF

- Special Council meeting held February 7, 2024

6. B. DISBURSEMENTS FROM FEBRUARY 2, 2024 TO MARCH 6, 2024

Total \$1,494,612.86

(One Million, Four Hundred Ninety-Four Thousand, Six Hundred Twelve Dollars and Eighty-Six Cents)

MOTION: Council Member Javier Vargas/Council Member Tadeo Azael De La Hoya to approve the Consent Agenda as presented. Motion passed unanimously.

The vote was as follows:

Mayor Nieves Riedel	Aye
Council Member Maria Cecilia Cruz	Aye
Council Member Matias Rosales	Aye
Council Member Javier Vargas	Aye
Council Member Tadeo Azael De La Hoya	Aye

7. DISCUSSION AND POSSIBLE ACTION ITEMS:

7. A. Discussion and possible action on any and all matters regarding the acceptance and award of a construction contract to DWD Construction for the municipal pool renovation and repair project. (Lizette Varela, Assistant Director of Parks and Recreation)

Ms. Lizette Varela, Assistant Director of Parks & Recreation, explained that staff held a bid opening and received two (2) bids; one (1) from Milan Pool Spas in the amount of \$225,145.12 and the other one from DWD Construction in the amount of \$250,359.67 plus \$36,500.00 for amenities and water features. After reviewing the bids, DWC was selected as the responsive bid and staff recommends awarding the bid to DWD Construction in the amount of \$286,859.67, as the only responsible and responsive bid allowed under the Recruitment Code of the City Code Section 3.05.040.

Mayor Nieves Riedel asked how long will the construction last or when will it be ready?

Ms. Angelica Roldan, Director of Parks & Recreation, responded that staff will be working continuously with the pool contractor to open the pool as soon as possible. She added that the city pool has not been opened for over a year. Having the water drain has caused much damage to the plaster and time will be needed for the new plaster to cure. Her department will work with the contractor to maintain a timeline with a tentative date of the end of June 2024.

The contractor stated that the construction process will be done before June 30th, plus 26 to 30 days for cure time, so it will be ready by the middle of July.

Council Member Matias Rosales stated that the city is being verbally told that it will be completed by the end of June and asked if there is a penalty if it is not completed by certain time frame?

Ms. Kay Macuil, City Attorney, stated there is a liquidated damages clause for delay included on the contract.

Council Member Tadeo Azael De La Hoya asked if the building will be needing any repairs or renovation?

Ms. Varela responded that currently staff is working on the budget and some repairs will be done inside the building.

MOTION: Council Member Javier Vargas/Council Member Maria Cecilia Cruz to approve the construction contract with DWD Construction in an amount not to exceed \$286,859.67, as presented. Motion passed unanimously.

The vote was as follows:

Mayor Nieves Riedel	Aye
Council Member Maria Cecilia Cruz	Aye
Council Member Matias Rosales	Aye
Council Member Javier Vargas	Aye
Council Member Tadeo Azael De La Hoya	Aye

7. B. Discussion and possible action on any and all matters regarding Ordinance No. 447. An Ordinance of the Mayor and City Council of the City of San Luis, Arizona, repealing San Luis Ordinance No. 442 City Code 6.05.31 License Requirements, 6.05.031 License and Tags Generally, and 6.05.033 License – Vaccination Requirements. (Nigel Reynoso, Chief of Police)

Mr. Nigel Reynoso, Chief of Police, indicated that they are seeking approval for Ordinance No. 447, which repeals some sections from Ordinance No. 442. He added that in June 2023, Ordinance No. 442 was approved, amending some sections of the City Code for Animal Control as well as establishing that the city was able to issue, regulate and enforce pet licenses. However, after implementation of the ordinance, both the Police Department and the Billing & Collections Department, determined that it was unable to properly service, support and adequately enforce the program due to lack of staff and license limitations. This will allow and maintain the licensing responsibility under the county.

Mayor Nieves Riedel asked how many Police Officers is the city short?

Chief Reynoso responded that by looking at the numbers it would be one (1), but based on the population the Police Department should have over 80 Police Officers, currently there are 41 Police Officers. He clarified that the enforcement would have been done by Animal Control and there is only one (1) Animal Control Officer for the entire city.

A. Action on Ordinance No. 447 by title only

MOTION: Council Member Tadeo Azael De La Hoya/Council Member Javier Vargas to approve the reading of Ordinance No. 447 by title only. Motion passed unanimously.

The vote was as follows:

Mayor Nieves Riedel	Aye
Council Member Maria Cecilia Cruz	Aye
Council Member Matias Rosales	Aye
Council Member Javier Vargas	Aye
Council Member Tadeo Azael De La Hoya	Aye

Mrs. Sonia Cornelio, City Clerk, read Ordinance No. 447 by title only.

B. Action on Ordinance No. 447

MOTION: Council Member Tadeo Azael De La Hoya/Council Member Javier Vargas to approve and adopt Ordinance No. 447 to repeal Ordinance No. 442 on Dog Licensing as presented. Motion passed unanimously.

The vote was as follows:

Mayor Nieves Riedel	Aye
Council Member Maria Cecilia Cruz	Aye
Council Member Matias Rosales	Aye
Council Member Javier Vargas	Aye
Council Member Tadeo Azael De La Hoya	Aye

7. C. Discussion and possible action on any and all matters regarding Resolution No. 2305. A Resolution of the Mayor and Council of the City of San Luis, Arizona, repealing dog license fees under Resolution No. 2278, Repealing conflicting provisions, and providing for severability. (Nigel Reynoso, Chief of Police)

Mr. Nigel Reynoso, Chief of Police, mentioned that in addition to the ordinance, staff is also seeking approval of Resolution No. 2305, which repeals Resolution No. 2278. Resolution No. 2278 was adopted on June 2023 establishing the dog licensing fees. Staff is recommending eliminating a dog licensing fee and turn it over to Yuma County Services who will continue to provide licenses with the approval of Resolution No. 2305.

MOTION: Council Member Javier Vargas/Council Member Tadeo Azael De La Hoya to approve and adopt Resolution No. 2305, repealing Resolution No. 2278, eliminating the City Dog Licensing fee. Motion passed unanimously.

The vote was as follows:

Mayor Nieves Riedel	Aye
Council Member Maria Cecilia Cruz	Aye
Council Member Matias Rosales	Aye
Council Member Javier Vargas	Aye
Council Member Tadeo Azael De La Hoya	Aye

7. D. Public Hearing followed by discussion and possible action on any and all matters regarding Rezoning Case No. 2023-0761 - Los Mezquites Townhomes 2 and Ordinance No. 448. An Ordinance of the Mayor and City Council of the City of San Luis, Arizona, amending the Official Zoning Map of the City of San Luis by changing the zoning classification of 10.31 acres from Medium Density Residential (R1-6) to Medium-High Density Residential (R-2) located east of 24th Avenue between Ortega Street and Nadine Street; repealing any conflicting provisions; and providing for severability. (Jose A. Guzman, Director of Development Services)

Mayor Nieves Riedel declared a conflict of interest on this item and abstained from participating. She asked Council Member Javier Vargas to take over this item.

A. Open Public Hearing

MOTION: Council Member Matias Rosales/Council Member Tadeo Azael De La Hoya to open the Public Hearing. Motion passed with four (4) Ayes and one (1) Abstention by Mayor Nieves Riedel.

The vote was as follows:

Mayor Nieves Riedel	Abstained
Council Member Maria Cecilia Cruz	Aye
Council Member Matias Rosales	Aye
Council Member Javier Vargas	Aye
Council Member Tadeo Azael De La Hoya	Aye

1. Staff presentation

Mr. Jose Guzman, Director of Development Services, stated that this is a request by Edais Engineering to rezone 10.31 acres from R-1-6 to R-2; the property is located east of 24th Avenue between Ortega Street and Nadine Street. The request for the R-2 will allow the applicant to build townhomes. The project is proposing to construct 84 attached town homes units. The subdivision will be named Mezquites Town Homes 2.

This item was presented to the Planning & Zoning Commission during their regular meeting on February 13, 2024. The Commission recommended approval of the request with the condition that the applicant will submit the preliminary plat when they submit the plat approval.

2. Call to the Public on this item

There were no comments from the public on this item.

B. Close Public Hearing

MOTION: Council Member Javier Vargas/Council Member Matias Rosales to close the Public Hearing. Motion passed with four (4) Ayes and one (1) Abstention by Mayor Nieves Riedel.

The vote was as follows:

Mayor Nieves Riedel	Abstained
Council Member Maria Cecilia Cruz	Aye
Council Member Matias Rosales	Aye
Council Member Javier Vargas	Aye
Council Member Tadeo Azael De La Hoya	Aye

C. Action on Ordinance No. 448 by title only

MOTION: Council Member Matias Rosales/Council Member Tadeo Azael De La Hoya to approve the reading of Ordinance No. 448 by title only. Motion passed with four (4) Ayes and one (1) Abstention by Mayor Nieves Riedel.

The vote was as follows:

Mayor Nieves Riedel	Abstained
Council Member Maria Cecilia Cruz	Aye
Council Member Matias Rosales	Aye
Council Member Javier Vargas	Aye
Council Member Tadeo Azael De La Hoya	Aye

Mrs. Sonia Cornelio, City Clerk, read Ordinance No. 448 by title only.

D. Action on Ordinance No. 448

MOTION: Council Member Tadeo Azael De La Hoya /Council Member Maria Cecilia Cruz to approve Ordinance No. 448. Motion passed with four (4) Ayes and one (1) Abstention by Mayor Nieves Riedel.

The vote was as follows:

Mayor Nieves Riedel	Abstained
Council Member Maria Cecilia Cruz	Aye
Council Member Matias Rosales	Aye
Council Member Javier Vargas	Aye
Council Member Tadeo Azael De La Hoya	Aye

7. E. Public Hearing followed by discussion and possible action on any and all matters regarding Rezoning Case No. 2024-0002 - Bienestar Estates 10 Townhomes and Ordinance No. 449. An Ordinance of the Mayor and City Council of the City of San Luis, Arizona, amending the Official Zoning Map of the City of San Luis by changing the zoning classification of 3.47 acres from Community Commercial (C-2) to Medium-High Density Residential (R-2) on property located at the southeast corner of Avenue F and County 24th Street; repealing any conflicting provisions; and providing for severability. (Jose A. Guzman, Director of Development Services)

A. Open Public Hearing

MOTION: Council Member Matias Rosales/Council Member Tadeo Azael De La Hoya to open the Public Hearing. Motion passed unanimously.

The vote was as follows:

Mayor Nieves Riedel	Aye
Council Member Maria Cecilia Cruz	Aye
Council Member Matias Rosales	Aye
Council Member Javier Vargas	Aye
Council Member Tadeo Azael De La Hoya	Aye

1. Staff presentation

Mr. Jose Guzman, Director of Development Services, stated that this is a request by Vega & Vega Engineering to rezone 3.47 acres from C-2 to R-2 for the construction of town homes which will contain 31 attached town home units and the subdivision will be named Bienestar Estates 10 Town Homes. This item was presented to the Planning & Zoning Commission during their meeting in February and recommended approval with the condition that the applicant will submit the full preliminary plat at the time of the subdivision submittal.

2. Call to the Public on this item

There were no comments from the public on this item.

B. Close Public Hearing

MOTION: Council Member Tadeo Azael De La Hoya/Council Member Matias Rosales to close the Public Hearing. Motion passed unanimously.

The vote was as follows:

Mayor Nieves Riedel	Aye
Council Member Maria Cecilia Cruz	Aye
Council Member Matias Rosales	Aye
Council Member Javier Vargas	Aye
Council Member Tadeo Azael De La Hoya	Aye

C. Action on Ordinance No. 449 by title only

MOTION: Council Member Tadeo Azael De La Hoya/Council Member Matias Rosales to approve the reading of Ordinance No. 449 by title only. Motion passed unanimously.

The vote was as follows:

Mayor Nieves Riedel	Aye
Council Member Maria Cecilia Cruz	Aye
Council Member Matias Rosales	Aye
Council Member Javier Vargas	Aye
Council Member Tadeo Azael De La Hoya	Aye

Mrs. Sonia Cornelio, City Clerk, read Ordinance No. 449 by title only.

D. Action on Ordinance No. 449

MOTION: Council Member Tadeo Azael De La Hoya /Council Member Javier Vargas to approve Ordinance No. 449. Motion passed unanimously.

The vote was as follows:

Mayor Nieves Riedel	Aye
Council Member Maria Cecilia Cruz	Aye
Council Member Matias Rosales	Aye
Council Member Javier Vargas	Aye
Council Member Tadeo Azael De La Hoya	Aye

8. SUMMARY OF CURRENT EVENTS

Mayor Nieves Riedel congratulated and thanked the Parks & Recreation Department for organizing the Safety Event, which she attended along with Council Members Maria Cecilia Cruz and Tadeo Azael De La Hoya.

Council Member Matias Rosales reported that he, other Elected Officials and staff have attended different local schools to participate in the Read Across America event. He also mentioned that he attended the Greater Yuma Port Authority Strategic Planning Retreat with their counterparts to discuss and figure out which direction the Port Authority is going to be heading, how it benefits the City of San Luis and the region. Additionally, he will be attending the monthly Greater Yuma Economic Development meeting tomorrow and on Monday he will attend the YCIPA meeting.

9. ADJOURNMENT

MOTION: Council Member Tadeo Azael De La Hoya/Council Member Maria Cecilia Cruz to adjourn the Regular Council meeting at approximately 6:45 p.m. Motion passed unanimously.

The vote was as follows:

Mayor Nieves Riedel	Aye
Council Member Maria Cecilia Cruz	Aye
Council Member Matias Rosales	Aye
Council Member Javier Vargas	Aye
Council Member Tadeo Azael De La Hoya	Aye

APPROVED:

Nieves Riedel, Mayor

ATTEST:

Sonia Cornelio, City Clerk

CERTIFICATION

I hereby certify that the foregoing minutes are a true and correct copy of the minutes of the Regular City Council meeting of the City Council of the City of San Luis, Arizona, held on March 13, 2024. I further certify that the meeting was duly called and held and that a quorum was present.

Sonia Cornelio, City Clerk



AGENDA ITEM REVIEW FORM

Regular City Council Meeting

6. B.

Meeting Date: 04/10/2024

Summary

DISBURSEMENTS FROM MARCH 20, 2024 TO APRIL 3, 2024

Total \$1,290,607.27

(One Million, Two Hundred Ninety Thousand, Six Hundred Seven Dollars and Cents)

Attachments

Disbursements



City of San Luis

Finance Department

COUNCIL MEETING APRIL 10, 2024
Disbursement Report from 03/20/2024 TO 04/03/2024

<u>Bank Accounts</u>	<u>Check Date</u>	<u>Amount</u>	<u>Schedule</u>
Accounts Payable Check Account	03/22/2024	\$ 341,744.56	Schedule A
Payroll Check Account	03/28/2024	\$ 498,430.21	Schedule B
Accounts Payable Check Account	03/29/2024	\$ 450,432.50	Schedule C

Total Disbursements: \$ 1,290,607.27

Please contact Ms. Roula Encinas or Mr. Miguel Ramirez prior to the meeting if additional information is needed.

341,744.56+
498,430.21+
450,432.50+
1,290,607.27

Prepared by Karla Plascencia: *K. Plascencia*

Verified by Finance: *Miguel Ramirez*

For Council approval on: *April 10, 2024*

Mayor: _____

Council: _____

RECEIVED

2024 APR -4 A 8:40

CITY OF SAN LUIS
OFFICE OF THE CITY CLERK

Payment Register

From Payment Date: 3/19/2024 - To Payment Date: 3/22/2024

Number	Date	Status	Void Reason	Reconciled/ Voided Date	Source	Payee Name	Transaction Amount	Reconciled Amount	Difference
1BYPAYABLE - 1st BY Accounts Payable									
<u>Check</u>									
108478	03/21/2024	Open			Accounts Payable	BOBADILLA, YADIRA	\$295.00		
108479	03/21/2024	Open			Accounts Payable	BOTELLO, EMMANUEL	\$116.00		
108480	03/21/2024	Open			Accounts Payable	CARRASCO, DANYA, P	\$61.02		
108481	03/21/2024	Open			Accounts Payable	DUENAS, DEREK	\$500.66		
108482	03/21/2024	Open			Accounts Payable	FELIX, ADRIANA	\$116.00		
108483	03/21/2024	Open			Accounts Payable	FELIX FELIX, YESENIA	\$200.00		
108484	03/21/2024	Open			Accounts Payable	FRAGOSO, CERVANDO	\$137.50		
108485	03/21/2024	Open			Accounts Payable	GUEVARA, GABRIELA	\$295.00		
108486	03/21/2024	Open			Accounts Payable	GUTIERREZ, ISAAC	\$232.00		
108487	03/21/2024	Open			Accounts Payable	HUERTA, JOSE	\$200.00		
108488	03/21/2024	Open			Accounts Payable	OCHOA , PRISCILA	\$200.00		
108489	03/21/2024	Open			Accounts Payable	VALENCIA, LINO	\$116.00		
108490	03/21/2024	Open			Accounts Payable	STANDARD INSURANCE CO.	\$13,527.43		
108491	03/22/2024	Open			Accounts Payable	AIRGAS USA LLC	\$2,947.81		
108492	03/22/2024	Open			Accounts Payable	ARIZONA DEPARTMENT OF ENVIRONMENTAL QUALITY	\$10,988.00		
108493	03/22/2024	Open			Accounts Payable	AT&T MOBILITY LLC	\$16,555.45		
108494	03/22/2024	Open			Accounts Payable	AUTOZONE STORES, INC	\$317.81		
108495	03/22/2024	Open			Accounts Payable	BINGHAM EQUIPMENT CO	\$7,545.13		
108496	03/22/2024	Open			Accounts Payable	BOUND TREE MEDICAL, LLC.	\$1,240.89		
108497	03/22/2024	Open			Accounts Payable	BREAKTHROUGH BASKETBALL ASSOCIATION	\$1,000.00		
108498	03/22/2024	Open			Accounts Payable	CARDIO PARTNERS, INC.	\$309.99		
108499	03/22/2024	Open			Accounts Payable	CENTURYLINK	\$384.72		
108500	03/22/2024	Open			Accounts Payable	CNJ AUTO GLASS & WINDOW TINTING, LLC	\$269.00		
108501	03/22/2024	Open			Accounts Payable	CONSTRUCTION SUPPLY HOLDINGS II, LLC	\$3,044.06		
108502	03/22/2024	Open			Accounts Payable	E.I.C. INC	\$7,198.50		
108503	03/22/2024	Open			Accounts Payable	EMPIRE MACHINERY	\$4,706.48		
108504	03/22/2024	Open			Accounts Payable	ENERSPECT MEDICAL SOLUTIONS, LLC	\$290.31		
108505	03/22/2024	Open			Accounts Payable	ERFERT, RICK	\$2,608.80		
108506	03/22/2024	Open			Accounts Payable	FERGUSON WATERWORKS	\$10,740.74		
108507	03/22/2024	Open			Accounts Payable	FERRELLGAS, LP	\$134.50		
108508	03/22/2024	Open			Accounts Payable	FIRERESQ, INC	\$492.06		
108509	03/22/2024	Open			Accounts Payable	FX TACTICAL, LLC	\$306.73		
108510	03/22/2024	Open			Accounts Payable	HAJOCA CORPORATION	\$1,070.70		
108511	03/22/2024	Open			Accounts Payable	HD SUPPLY, INC.	\$218.87		
108512	03/22/2024	Open			Accounts Payable	HOWMEDICA OSTEONICS CORP	\$909.44		
108513	03/22/2024	Open			Accounts Payable	HUGHES FIRE EQUIPMENT, INC.	\$886.25		
108514	03/22/2024	Open			Accounts Payable	ID WHOLESALER	\$1,151.17		
108515	03/22/2024	Open			Accounts Payable	LA BODEGA, LLC	\$996.48		
108516	03/22/2024	Open			Accounts Payable	LAW OFFICE OF HEATHER C. VINCI PLLC	\$8,000.00		
108517	03/22/2024	Open			Accounts Payable	LAWSON PRODUCTS INC.	\$116.75		
108518	03/22/2024	Open			Accounts Payable	LOOMIS	\$3,252.92		
108519	03/22/2024	Open			Accounts Payable	PATHWAY VET ALLIANCE HOLDING LLC	\$2,105.24		

SCHEDULE A

Payment Register

From Payment Date: 3/19/2024 - To Payment Date: 3/22/2024

Number	Date	Status	Void Reason	Reconciled/ Voided Date	Source	Payee Name	Transaction Amount	Reconciled Amount	Difference
108520	03/22/2024	Open			Accounts Payable	PEACEKEEPER PRODUCTS INT'L	\$1,517.47		
108521	03/22/2024	Open			Accounts Payable	REMINGTON INDUSTRIAL SUPPLY LLC	\$356.59		
108522	03/22/2024	Open			Accounts Payable	RUSH INDEX TABS INC.	\$585.20		
108523	03/22/2024	Open			Accounts Payable	SOCIAL DEMICS LLC	\$1,200.00		
108524	03/22/2024	Open			Accounts Payable	TISCHLERBISE, INC.	\$6,170.00		
108525	03/22/2024	Open			Accounts Payable	TORNADO FENCE LLC	\$4,540.00		
108526	03/22/2024	Open			Accounts Payable	TRUCKMATES LLC	\$52.04		
108527	03/22/2024	Open			Accounts Payable	TYLER TECHNOLOGIES, INC.	\$390.00		
108528	03/22/2024	Open			Accounts Payable	US POST MASTER	\$2,579.30		
108529	03/22/2024	Open			Accounts Payable	XEROX CORPORATION	\$45.22		
108530	03/22/2024	Open			Accounts Payable	YUMA COUNTY SUPERIOR COURT	\$5,721.41		
108531	03/22/2024	Open			Accounts Payable	YUMA OVERHEAD DOOR CO. INC	\$470.00		
108532	03/22/2024	Open			Accounts Payable	YUMA WINLECTRIC CO.	\$1,309.13		
108533	03/22/2024	Open			Accounts Payable	O'REILLY AUTO PARTS	\$669.48		
Type Check Totals:									
EFT									
5118	03/22/2024	Open			Accounts Payable	4 IMPRINT	\$3,018.22		
5119	03/22/2024	Open			Accounts Payable	ALLKIOSK LLC	\$1,023.89		
5120	03/22/2024	Open			Accounts Payable	ALSCO, INC	\$2,691.83		
5121	03/22/2024	Open			Accounts Payable	AMAZON.COM SALES, INC.	\$1,651.54		
5122	03/22/2024	Open			Accounts Payable	AMBERLY'S PLACE	\$3,500.00		
5123	03/22/2024	Open			Accounts Payable	AMERICANA POLYGRAPH & PRIVATE INVESTIGATION	\$175.00		
5124	03/22/2024	Open			Accounts Payable	B&H PHOTO & ELECTRONICS CORP.	\$126.00		
5125	03/22/2024	Open			Accounts Payable	BERKLEY RISK ADMINISTRATORS COMPANY	\$6,424.20		
5126	03/22/2024	Open			Accounts Payable	BILL ALEXANDER FORD	\$3,913.10		
5127	03/22/2024	Open			Accounts Payable	BTE BODY COMPANY INC	\$28,166.67		
5128	03/22/2024	Open			Accounts Payable	CAT5 COMMERCE LLC	\$121.78		
5129	03/22/2024	Open			Accounts Payable	CDWG	\$2,233.29		
5130	03/22/2024	Open			Accounts Payable	CENTERLINE SUPPLY WEST	\$3,714.43		
5131	03/22/2024	Open			Accounts Payable	CMI INC.	\$211.00		
5132	03/22/2024	Open			Accounts Payable	CUEVAS, CHRISTIAN	\$50.00		
5133	03/22/2024	Open			Accounts Payable	DELL MARKETING L.P.	\$3,726.21		
5134	03/22/2024	Open			Accounts Payable	DESERT VALLEY SERVICES, INC	\$1,077.65		
5135	03/22/2024	Open			Accounts Payable	DESERT WATER STORE INC	\$150.07		
5136	03/22/2024	Open			Accounts Payable	FONSECA, BRIANDA	\$1,070.00		
5137	03/22/2024	Open			Accounts Payable	FRESH TERRA SERVICES LLC	\$2,692.00		
5138	03/22/2024	Open			Accounts Payable	HILL BROTHERS CHEMICAL CO.	\$21,987.14		
5139	03/22/2024	Open			Accounts Payable	HUMANE SOCIETY OF YUMA	\$4,166.67		
5140	03/22/2024	Open			Accounts Payable	JAMES DAVEY AND ASSOCIATES INC	\$17,100.00		
5141	03/22/2024	Open			Accounts Payable	JSA COMPANY	\$12,346.00		
5142	03/22/2024	Open			Accounts Payable	KINGHOSE INDUSTRY LLC	\$2,045.04		
5143	03/22/2024	Open			Accounts Payable	KTL&C, LLC.	\$265.44		
5144	03/22/2024	Open			Accounts Payable	LIFE-ASSIST, INC.	\$2,357.34		
5145	03/22/2024	Open			Accounts Payable	ODP BUSINESS SOLUTIONS LLC	\$3,683.50		

Payment Register

From Payment Date: 3/19/2024 - To Payment Date: 3/22/2024

Number	Date	Status	Void Reason	Reconciled/ Voided Date	Source	Payee Name	Transaction Amount	Reconciled Amount	Difference
5146	03/22/2024	Open			Accounts Payable	PACIFIC ADVANCED CIVIL ENGINEERING INC	\$24,798.00		
5147	03/22/2024	Open			Accounts Payable	POLAR ICE LLC	\$504.29		
5148	03/22/2024	Open			Accounts Payable	PRECISION PROTECTIVE SERVICES LLC	\$14,776.08		
5149	03/22/2024	Open			Accounts Payable	REAL PURIFIED WATER LLC	\$173.41		
5150	03/22/2024	Open			Accounts Payable	ROACH PEST CONTROL	\$910.00		
5151	03/22/2024	Open			Accounts Payable	SOUTHERN TIRE MART LLC	\$5,037.37		
5152	03/22/2024	Open			Accounts Payable	SPECTRUM BUSINESS	\$725.76		
5153	03/22/2024	Open			Accounts Payable	STANDARD PRINTING COMPANY, INC	\$1,295.19		
5154	03/22/2024	Open			Accounts Payable	THOMSON WEST PUBLISHING CO.	\$2,624.88		
5155	03/22/2024	Open			Accounts Payable	U.S. SAWS, INC.	\$6,631.25		
5156	03/22/2024	Open			Accounts Payable	ULINE, INC.	\$8,557.03		
5157	03/22/2024	Open			Accounts Payable	VAPEX ENVIRONMENTAL TECHNOLOGIES, LLC	\$116.25		
5158	03/22/2024	Open			Accounts Payable	WAXIE SANITARY SUPPLY	\$661.90		
5159	03/22/2024	Open			Accounts Payable	YUMA CO. AIRPORT AUTHORITY INC	\$167.79		
5160	03/22/2024	Open			Accounts Payable	YUMA NURSERY LLC	\$6,014.67		
5161	03/22/2024	Open			Accounts Payable	YUMA SIGN MASTERS LLC	\$4,577.74		
5162	03/22/2024	Open			Accounts Payable	YUMA WINNELSON CO.	\$598.98		
5163	03/22/2024	Open			Accounts Payable	ZOLL MEDICAL CORP	\$2,494.91		
Type EFT Totals:							\$210,353.51		
1BYPAYABLE - 1st BY Accounts Payable Totals									

Checks	Status	Count	Transaction Amount	Reconciled Amount
	Open	56	\$131,391.05	\$0.00
	Reconciled	0	\$0.00	\$0.00
	Voided	0	\$0.00	\$0.00
	Stopped	0	\$0.00	\$0.00
	Total	56	\$131,391.05	\$0.00

Payment Register

From Payment Date: 3/19/2024 - To Payment Date: 3/22/2024

Number	Date	Status	Void Reason	Reconciled/ Voided Date	Source	Payee Name	Transaction Amount	Reconciled Amount	Difference
				EFTs	Status	Count	Transaction Amount	Reconciled Amount	
					Open	46	\$210,353.51	\$0.00	
					Reconciled	0	\$0.00	\$0.00	
					Voided	0	\$0.00	\$0.00	
					Total	46	\$210,353.51	\$0.00	
				All	Status	Count	Transaction Amount	Reconciled Amount	
					Open	102	\$341,744.56	\$0.00	
					Reconciled	0	\$0.00	\$0.00	
					Voided	0	\$0.00	\$0.00	
					Stopped	0	\$0.00	\$0.00	
					Total	102	\$341,744.56	\$0.00	
Grand Totals:									
				Checks	Status	Count	Transaction Amount	Reconciled Amount	
					Open	56	\$131,391.05	\$0.00	
					Reconciled	0	\$0.00	\$0.00	
					Voided	0	\$0.00	\$0.00	
					Stopped	0	\$0.00	\$0.00	
					Total	56	\$131,391.05	\$0.00	
				EFTs	Status	Count	Transaction Amount	Reconciled Amount	
					Open	46	\$210,353.51	\$0.00	
					Reconciled	0	\$0.00	\$0.00	
					Voided	0	\$0.00	\$0.00	
					Total	46	\$210,353.51	\$0.00	
				All	Status	Count	Transaction Amount	Reconciled Amount	
					Open	102	\$341,744.56	\$0.00	
					Reconciled	0	\$0.00	\$0.00	
					Voided	0	\$0.00	\$0.00	
					Stopped	0	\$0.00	\$0.00	
					Total	102	\$341,744.56	\$0.00	

Guadalupe Canez

Digitally signed by: Guadalupe Canez
 DN: CN = Guadalupe Canez email =
 gganez@sanluisaz.gov C = AD
 Date: 2024.03.22 15:13:51 -07'00'



Pay Day Register

Pay Date Range 03/09/24 - 03/22/24

Pay Batch 202407

Pay Batch 202407 Total

Employees in Pay Batch 321

Female Employees in Pay Batch 92

Hours Description	Hours	Gross	Withholdings and Deductions	Gross Base	Benefits	Gross Base
100 - REGULAR	23,535.2000	563,565.47	Gross	683,642.66	ASRS ALTERNATE	512.34
1001 - LEAVE WITHOUT PAY	90.4600	.00	Imputed Income		AZ STATE RETIREMENT	49,078.01
1005 - BEREAVEMENT	72.0000	1,508.40	FEDERAL TAX WITHHOLDING	42,451.17	LONG TERM DISABILITY	606.39
1007 - ON CALL WORKED HOURS	22.5000	442.26	SOCIAL SECURITY TAX	42,385.85	PSPRS - ALTERNATE	270.63
1009 - PART TIME	319.8638	6,981.92	MEDICARE	9,912.97	PSPRS FIRE DB NORM - TIER 1	8,983.92
1010 - PART TIME FIREFIGHTERS	117.7500	2,322.06	STATE WITHHOLDING	13,357.35	PSPRS FIRE DB NORM - TIER 2	610.86
201 - OVERTIME	678.0000	26,333.77	AZ STATE RETIREMENT	49,078.01	PSPRS FIRE DB NORM - TIER 3	4,798.05
202 - OP STONE GARDEN- O.T.	543.0000	27,275.07	DEFERRED COMP - ROTH	350.00	PSPRS POLICE DB NORM - TIER	7,085.12
2023 - FMLA - SICK LEAVE	274.5600	7,208.43	DEFERRED COMP - ROTH	287.24	PSPRS POLICE DB NORM - TIER	1,220.80
2024 - FMLA - VACATION LEAVE	143.0500	2,732.76	DEFERRED COMPENSATION	2,865.00	PSPRS POLICE DB NORM - TIER	4,152.25
203 - DUI ABATEMENT	14.0000	607.98	DEFERRED COMPENSATION	931.82	Total	\$77,318.37
210 - SRO	73.0000	2,288.56	GARNISHMENT - CHILD	235.16		
300 - VACATION EARNED	1,237.7500	.00	LONG TERM DISABILITY	606.39	Employer Taxes	Gross Base
301 - VACATION USED	664.0900	18,192.00	MEXICO ONLY HEALTH - EE &	71.61	MEDICARE	9,912.97
400 - SICK EARNED	1,197.0550	.00	MISCELLANEOUS	65.00	SOCIAL SECURITY TAX	42,385.85
405 - SCHEDULED SICK LEAVE	354.8300	7,882.53	PS DEFERRED COMP - ROTH	320.00	SUTA/UNEMPLOYMENT	3,929.09
406 - UNSCHEDULED SICK LEAVE	560.3500	12,703.41	PS DEFERRED COMP TIAA -	112.78	Total	\$56,227.91
502 - ON CALL PAY I.T.	.0000	100.00	PS DEFERRED COMPENSATION	680.00		
503 - STAND-BY PAY	645.1200	1,290.24	PSPRS FIRE DB RATE - TIER 1a	4,344.77	Workers' Comp	Gross Base
900 - COMPENSATION EARNED	2.0000	.00	PSPRS FIRE DB RATE - TIER 1b	889.56	Ambulance EMT Search &	2,883.99
901 - COMPENSATION USED	7.4950	144.04	PSPRS FIRE DB RATE - TIER 2	355.91	ANIMAL CONTROL OFFICERS	32.92
921 - STEP OVERTIME	4.0000	218.76	PSPRS FIRE DB RATE - TIER 3	4,798.05	ATTORNEY- ALL & CLERICAL-	53.10
965 - PD - STAND-BY PAY	.0000	1,845.00	PSPRS POLICE DB RATE - TIER	4,316.30	AUTO SERVICE/ REPAIR	291.89
Total	30,556.0738	\$683,642.66	PSPRS POLICE DB RATE - TIER	1,431.43	BUILDING- NOC OPER BY	575.57
			PSPRS POLICE DB RATE - TIER 2	990.36	BUS COMPANY AND DRIVERS	90.29
			PSPRS POLICE DB RATE - TIER 3	4,152.25	CLERICAL OFFICE/ LIBRARY/	394.55
			US & MEX DENTAL= FAMILY	2.55	Electrician	68.58
			US & MEX HEALTH = C	133.22	FIREFIGHTERS & DRIVERS	3,274.03
			US & MEX HEALTH = FAMILY	37.70	GARBAGE/ ASH/ REFUSE	652.21
			US & MEX HEALTH = SP	29.09	Homemaker Service	39.97
			VSP - VISION SPOUSE	20.91	MUNICIPAL/ TOWN/	711.95
			Net	\$498,430.21	PARKS- NOC ALL EMPLOYEES	760.02
					POLICE OFFICERS	7,044.97
					RECREATION- ALL EMPLOYEES/	304.27
					SEWAGE DISPOSAL/ PLANT	1,027.53
					Street or Road Construction	2,601.70
					WATERWORKS OPERATIONS	922.64
					Total	\$21,730.18

Roula J. de Encinas

Digitally signed by: Roula J. de Encinas
DN: CN = Roula J. de Encinas
email = rencinas@sanluisaz.gov
C = US O = City of San Luis
Date: 2024.03.28 09:46:25 -0700

SCHEDULE B



Pay Day Register

Pay Date Range 03/09/24 - 03/22/24

Pay Batch 202407

<u>Direct Deposits</u>	<u>Amount</u>
1st Bank Yuma	46,669.00
ACADEMY BANK	2,607.29
Bank of America	7,711.11
Bank of America CA	1,099.99
Bankcorp	200.00
CAPITAL ONE	714.07
Charles Sch	250.00
Chase Bank	233,041.55
CHASE BANK CA	1,353.52
CHASE BANK MORGAN	2,967.79
CHASE BANK TX	2,287.86
chase centro	1,826.05
discover	400.00
Federal Credit Union	40,061.48
FF CREDIT UNION	2,431.36
FIDELITY	310.31
FIREFIGHTER FIRST CREDIT UNION	6,059.69
HUGHES FCU	2,024.13
MECHNICS BANK	1,259.81
National Bank	1,289.84
Navy Federal	26,187.46
NetSpend Corporation DD	120.00
NORTH ISLAND CREDIT UNION	844.95
PATHWARD	2,555.49
Sunbank	2,493.44
THE FOOTHILLS BANK	902.73
VANTAGE WEST	1,922.27
WASHINGTON FEDERAL	1,202.22
Wells Fargo	98,702.72
WELLS FARGO CA	3,924.32
WELLS FARGO CALE	622.61
WELLS FARGO YUMA	2,966.72
Total	<u>\$497,009.78</u>
Check	\$1,420.43

Payment Register

From Payment Date: 3/25/2024 - To Payment Date: 3/29/2024

Number	Date	Status	Void Reason	Reconciled/ Voided Date	Source	Payee Name	Transaction Amount	Reconciled Amount	Difference
1BYPAYABLE - 1st BY Accounts Payable									
Check									
108534	03/25/2024	Open			Accounts Payable	AZ DEPARTMENT OF TRANSPORTATION	\$27,172.00		
108535	03/25/2024	Open			Utility Management Refund	MACIAS, SANDRA	\$230.00		
108536	03/27/2024	Open			Accounts Payable	TACOS EL CHIPILON, LLC	\$218.88		
108537	03/29/2024	Open			Accounts Payable	AFFORDABLE TOWING AND ROAD SERVICE	\$90.00		
108538	03/29/2024	Open			Accounts Payable	ANGEL'S TOWING SERVICE/AUTO SALES	\$180.00		
108539	03/29/2024	Open			Accounts Payable	APS	\$50.00		
108540	03/29/2024	Open			Accounts Payable	BARRIENTOS, LORENZO	\$750.00		
108541	03/29/2024	Open			Accounts Payable	BILL ALEXANDER FORD	\$52,307.94		
108542	03/29/2024	Open			Accounts Payable	BOUND TREE MEDICAL, LLC.	\$5,849.80		
108543	03/29/2024	Open			Accounts Payable	CALIFORNIA ENVIRONMENTAL CONTROLS, INC	\$58,700.00		
108544	03/29/2024	Open			Accounts Payable	EMAZON, JESUS	\$336.00		
108545	03/29/2024	Open			Accounts Payable	ERFERT, RICK	\$1,892.34		
108546	03/29/2024	Open			Accounts Payable	ESPINOSA ZEREGA, LOUIS, REY	\$500.00		
108547	03/29/2024	Open			Accounts Payable	FACTOR SALES, INC.	\$54.25		
108548	03/29/2024	Open			Accounts Payable	FERGUSON WATERWORKS	\$255.18		
108549	03/29/2024	Open			Accounts Payable	FIREFIGHTER SELECTION, INC.	\$750.00		
108550	03/29/2024	Open			Accounts Payable	GARCIA, FRANCISCO	\$200.00		
108551	03/29/2024	Open			Accounts Payable	GARCIA, JESUS	\$240.00		
108552	03/29/2024	Open			Accounts Payable	GARCIA, JESUS	\$845.00		
108553	03/29/2024	Open			Accounts Payable	GARCIA, JESUS	\$150.00		
108554	03/29/2024	Open			Accounts Payable	GH MANAGEMENT, LLC	\$3,297.37		
108555	03/29/2024	Open			Accounts Payable	GROUP C MEDIA INC	\$1,850.00		
108556	03/29/2024	Open			Accounts Payable	HAJOCA CORPORATION	\$42.81		
108557	03/29/2024	Open			Accounts Payable	HD SUPPLY, INC.	\$223.12		
108558	03/29/2024	Open			Accounts Payable	LEON-CAMBREROS, ANGEL	\$1,000.00		
108559	03/29/2024	Open			Accounts Payable	LOPEZ, MARIA, JULIETA	\$500.00		
108560	03/29/2024	Open			Accounts Payable	MACHADO, IVAN & AIXIA GUTIERREZ	\$300.00		
108561	03/29/2024	Open			Accounts Payable	MALDONADO PARRA, JESUS	\$1,000.00		
108562	03/29/2024	Open			Accounts Payable	MARKETINK DESIGN AND PRINTING	\$143.92		
108563	03/29/2024	Open			Accounts Payable	MORALES, ALEJANDRO	\$87.00		
108564	03/29/2024	Open			Accounts Payable	MUNOZ, JOSHUA	\$137.50		
108565	03/29/2024	Open			Accounts Payable	NOMAR DEVELOPMENTS INC,	\$12,000.00		
108566	03/29/2024	Open			Accounts Payable	NUNO, JAVIER	\$209.00		
108567	03/29/2024	Open			Accounts Payable	PARRA, DANIEL, A.	\$200.00		
108568	03/29/2024	Open			Accounts Payable	PRIETO, ERNESTO	\$183.72		
108569	03/29/2024	Open			Accounts Payable	PVP COMMUNICATIONS INC.	\$44.00		
108570	03/29/2024	Open			Accounts Payable	QUINONEZ, FRANCISCO	\$270.00		
108571	03/29/2024	Open			Accounts Payable	ROMERO TORRES, MARIA , GUADALUPE	\$500.00		
108572	03/29/2024	Open			Accounts Payable	ROSALES, ROBERTO	\$150.00		
108573	03/29/2024	Open			Accounts Payable	RUIZ, OSCAR	\$209.00		

SCHEDULE C

Payment Register

From Payment Date: 3/25/2024 - To Payment Date: 3/29/2024

Number	Date	Status	Void Reason	Reconciled/ Voided Date	Source	Payee Name	Transaction Amount	Reconciled Amount	Difference
108574	03/29/2024	Open			Accounts Payable	RUSH TRUCK CENTERS OF ARIZONA, INC	\$16,600.00		
108575	03/29/2024	Open			Accounts Payable	SANTANA, PEDRO, LUIS	\$1,200.00		
108576	03/29/2024	Open			Accounts Payable	SILVA, MIGUEL, ANGEL	\$1,000.00		
108577	03/29/2024	Open			Accounts Payable	SOUTHWEST TURF SUPPLY	\$8,876.23		
108578	03/29/2024	Open			Accounts Payable	TENCZA, BRIAN	\$372.86		
108579	03/29/2024	Open			Accounts Payable	THE WINDOOR SHOP	\$372.33		
108580	03/29/2024	Open			Accounts Payable	TORRES, JESUS, A	\$216.00		
108581	03/29/2024	Open			Accounts Payable	VALENZUELA, JAIME	\$116.00		
108582	03/29/2024	Open			Accounts Payable	WALKER, BARBARA	\$200.00		
108583	03/29/2024	Open			Accounts Payable	YUMA WINLECTRIC CO.	\$3,100.58		
108584	03/29/2024	Open			Accounts Payable	ZARAGOZA, LETICIA	\$75.00		
108585	03/29/2024	Open			Accounts Payable	LD CONSULTING LLC	\$1,398.00		
108586	03/29/2024	Open			Accounts Payable	R.D. OFFUTT COMPANY	\$1,379.29		
108587	03/29/2024	Open			Accounts Payable	STRONG, CAMERON, T	\$1,905.00		
108588	03/29/2024	Open			Accounts Payable	SUPPORT PAYMENT CLEARINGHOUSE	\$235.16		
Type Check Totals:						55 Transactions	\$210,165.28		
EFT									
5165	03/29/2024	Open			Accounts Payable	4 IMPRINT	\$3,815.87		
5166	03/29/2024	Open			Accounts Payable	ADEMCO INC,	\$361.06		
5167	03/29/2024	Open			Accounts Payable	ARIZONA MUNICIPAL RISK RETENTION POOL P&C	\$183,344.00		
5168	03/29/2024	Open			Accounts Payable	B&H PHOTO & ELECTRONICS CORP.	\$26.63		
5169	03/29/2024	Open			Accounts Payable	BILL ALEXANDER FORD	\$1,772.10		
5170	03/29/2024	Open			Accounts Payable	CORE ENGINEERING GROUP, PLLC	\$609.20		
5171	03/29/2024	Open			Accounts Payable	DANA KEPNER COMPANY LLC	\$860.87		
5172	03/29/2024	Open			Accounts Payable	DESERT DOCUMENT SHREDDERS, LLC	\$72.75		
5173	03/29/2024	Open			Accounts Payable	DESERT WATER STORE INC	\$189.27		
5174	03/29/2024	Open			Accounts Payable	DESTINY SOFTWARE, INC	\$1,155.00		
5175	03/29/2024	Open			Accounts Payable	DICKINSON WRIGHT PLLC	\$1,015.00		
5176	03/29/2024	Open			Accounts Payable	FONSECA, BRIANDA	\$1,090.00		
5177	03/29/2024	Open			Accounts Payable	FRESH TERRA SERVICES LLC	\$382.00		
5178	03/29/2024	Open			Accounts Payable	FRUTH GROUP INC	\$455.56		
5179	03/29/2024	Open			Accounts Payable	HANSBERGER REGRIGERATION & ELECTRIC CO	\$980.00		
5180	03/29/2024	Open			Accounts Payable	HEINFELD, MEECH & CO., P.C.	\$7,725.00		
5181	03/29/2024	Open			Accounts Payable	HILL BROTHERS CHEMICAL CO.	\$10,188.02		
5182	03/29/2024	Open			Accounts Payable	JCG TECHNOLOGIES INC.	\$625.00		
5183	03/29/2024	Open			Accounts Payable	LG ON SITE LLC	\$506.37		
5184	03/29/2024	Open			Accounts Payable	LIFE-ASSIST, INC.	\$3,762.33		
5185	03/29/2024	Open			Accounts Payable	MAJCO LLC	\$179.98		
5186	03/29/2024	Open			Accounts Payable	METRO FIRE EQUIPMENT INC	\$336.00		
5187	03/29/2024	Open			Accounts Payable	NAPA AUTO PARTS	\$95.09		
5188	03/29/2024	Open			Accounts Payable	RWC INTERNATIONAL LTD	\$5,300.32		
5189	03/29/2024	Open			Accounts Payable	SOUTHERN TIRE MART LLC	\$670.85		
5190	03/29/2024	Open			Accounts Payable	SUN GRAPHICS	\$1,238.63		
5191	03/29/2024	Open			Accounts Payable	SUN RENTAL AND SALES INC.	\$9,534.60		

Payment Register

From Payment Date: 3/25/2024 - To Payment Date: 3/29/2024

Number	Date	Status	Void Reason	Reconciled/ Voided Date	Source	Payee Name	Transaction Amount	Reconciled Amount	Difference
5192	03/29/2024	Open			Accounts Payable	WESTERN SUN SYSTEMS, INC	\$516.00		
5193	03/29/2024	Open			Accounts Payable	YUMA AUTO REBUILDERS LLC	\$846.13		
5194	03/29/2024	Open			Accounts Payable	YUMA SIGN MASTERS LLC	\$227.67		
5195	03/29/2024	Open			Accounts Payable	YUMA SUN INC	\$987.02		
5196	03/29/2024	Open			Accounts Payable	YUMA WINNELSON CO.	\$395.70		
5200	03/29/2024	Open			Accounts Payable	FONSECA, BRIANDA	\$1,003.20		
33 Transactions							<u>\$240,267.22</u>		

Type EFT Totals:
1BYPAYABLE - 1st BY Accounts Payable Totals

Checks	Status	Count	Transaction Amount	Reconciled Amount
	Open	55	\$210,165.28	\$0.00
	Reconciled	0	\$0.00	\$0.00
	Voided	0	\$0.00	\$0.00
	Stopped	0	\$0.00	\$0.00
	Total	55	\$210,165.28	\$0.00

EFTs	Status	Count	Transaction Amount	Reconciled Amount
	Open	33	\$240,267.22	\$0.00
	Reconciled	0	\$0.00	\$0.00
	Voided	0	\$0.00	\$0.00
	Total	33	\$240,267.22	\$0.00

All	Status	Count	Transaction Amount	Reconciled Amount
	Open	88	\$450,432.50	\$0.00
	Reconciled	0	\$0.00	\$0.00
	Voided	0	\$0.00	\$0.00
	Stopped	0	\$0.00	\$0.00
	Total	88	\$450,432.50	\$0.00

Grand Totals:

Checks	Status	Count	Transaction Amount	Reconciled Amount
	Open	55	\$210,165.28	\$0.00
	Reconciled	0	\$0.00	\$0.00
	Voided	0	\$0.00	\$0.00
	Stopped	0	\$0.00	\$0.00
	Total	55	\$210,165.28	\$0.00

EFTs	Status	Count	Transaction Amount	Reconciled Amount
	Open	33	\$240,267.22	\$0.00
	Reconciled	0	\$0.00	\$0.00
	Voided	0	\$0.00	\$0.00
	Total	33	\$240,267.22	\$0.00

All	Status	Count	Transaction Amount	Reconciled Amount
	Open	88	\$450,432.50	\$0.00
	Reconciled	0	\$0.00	\$0.00
	Voided	0	\$0.00	\$0.00
	Stopped	0	\$0.00	\$0.00
	Total	88	\$450,432.50	\$0.00

Guadalupe Canez

Digitally signed by: Guadalupe Canez
DN: CN = Guadalupe Canez email =
gganez@sanluisaz.gov C = AD
Date: 2024.03.28 17:28:45 -07'00'



AGENDA ITEM REVIEW FORM

Regular City Council Meeting

7. A.

Meeting Date: 04/10/2024

Department Head: Sonia Cornelio, City Clerk, City Clerk's Office

Submitted By: Sonia Cornelio, City Clerk, City Clerk's Office

Action Requested: Motion

ITEM:

Discussion and possible action on any and all matters regarding the appointment of poll workers for the Special Election scheduled for May 21, 2024. **(Sonia Cornelio, City Clerk)**

SUMMARY:

The City of San Luis is preparing for the Special Election scheduled for May 21, 2024. Currently, there is an IGA with Yuma County for the provision of election services, therefore, they will be assisting the city with the special election.

A.R.S. §16-531 (C) provides that if a nonpartisan election is ordered, not less than twenty days before the election, the governing board holding the election shall appoint, without consideration for political party, a minimum of three election workers for each polling place. The election workers shall consist of at least one inspector and two judges. Whenever possible, they shall be qualified electors of the precinct located within the district, without consideration for political party.

The Vote Centers will be the Yuma County Library - San Luis Branch and the San Luis Medical Mall. The polling place will be open from 6:00 a.m. to 7:00 p.m. on the date of the Special Election.

RECOMMENDATION / SUGGESTED MOTION:

I MOVE TO APPROVE AND APPOINT THE POLL WORKERS AS PRESENTED AND TO AUTHORIZE SUBSTITUTIONS AND ADDITIONS AS MAY BE NECESSARY BY THE ELECTION SERVICES DIRECTOR FOR THE SPECIAL ELECTION ON MAY 21, 2024.

Fiscal Impact

IS THERE FISCAL IMPACT ASSOCIATED WITH THIS ITEM: N/A

CITY/STATE/FEDERAL FUNDS: N/A

TOTAL: N/A

BUDGETED AMOUNT: N/A

AVAILABLE AMOUNT TO TRANSFER: N/A

ACCT NAME & GL#/REMAINING BALANCE BEFORE PURCHASE: N/A

FISCAL IMPACT STATEMENT (IF THIS IS A BUDGET TRANSFER, YOU MUST ATTACH THE BUDGET ADJUSTMENT FORM):

N/A

Attachments

List - Election Workers 5/21/2024 Special Election

IGA - Yuma County

Sonia Cornelio

From: Kika Guzman <Kika.Guzman@yumacountyaz.gov>
Sent: Friday, March 29, 2024 11:29 AM
To: Sonia Cornelio
Cc: Melissa Lopez; Jessica Martin; Richard Colwell
Subject: Election Worker List for Special Election

Good morning Sonia,

Below this email, please find a list of workers to be appointed by your board. Please add the following language to the board's approval: "Authorize substitutions and additions as may be necessary for the May 21, 2024, Special Election by the Election Services Director".

Special Election - May 21, 2024			
Election Boards			
Medical Mall		San Luis Library	
Position	Name	Position	Name
Inspector	David Yglesias	Inspector	Virginia Guzman
Marshal	Rosy Vasquez	Marshal	Miguel Sanchez
Poll Pad Judge	Bryce Presley	Poll Pad Judge	Laura Navejar
Poll Pad Judge	Debra Pallack	Poll Pad Judge	Andrea Ramirez
Poll Pad Judge	Sandra Saucedo	Poll Pad Judge	Katie Thorson
Poll Pad Judge	Antonio D. Bustamante	Poll Pad Judge	Salome Franco
Printer Judge	Daniel Ortiz	Printer Judge	Diana Martinez
ExpressVote Clerk	Joseph Anthony Gonzalez	ExpressVote Clerk	Anamarie Escalera
Tabulator Clerk	Javier Barraza	Tabulator Clerk	Constance Muccianti
Provisional Clerk	Irene Lett	Provisional Clerk	Otilia Escalera
Provisional Clerk	Ana Maria Dueñas	Provisional Clerk	Teresa Sanders
Floater Clerk	Rachel Uresti	Floater Clerk	Maria Mendez
Early Board		Duplication Board	
Position	Name	Position	Name
Early Board Supervisor	Margarita Haro Abalos	Judge	Jodi Merrill Russell
Inspector	Carolyn Marquez	Judge	Brad Broschat
Judge	Larry Graef		
Judge	Ruth Sust		

Thank you,

Kika



Kika Guzman, CERA | Election Services Director
County Recorder Office | 102 S. Main St. Yuma, AZ 85364
T: (928) 373-1019 | Kika.Guzman@yumacountyaz.gov
www.yumacountyaz.gov/voterandelectionservices



Order

OFFICE OF THE
MAYOR
CITY OF SAN LUIS

No. 2023-13

AN ORDER OF THE MAYOR AND CITY COUNCIL OF THE CITY OF SAN LUIS, ARIZONA, AUTHORIZING AND DIRECTING THE ENTERING INTO AN INTERGOVERNMENTAL AGREEMENT WITH YUMA COUNTY ARIZONA, PROVIDING FOR ELECTION SERVICES. REPEALING CONFLICTING PROVISIONS AND PROVIDING FOR SEVERABILITY.

WHEREAS, Arizona Revised Statute § 11-952 authorizes Arizona cities and counties to enter into intergovernmental agreements; and

WHEREAS, on February 20, 2019, the City of San Luis and Yuma County entered into a five-year contract for election services, which will expire on February 20, 2024, and

WHEREAS the City of San Luis desires to continue election services through the expertise of Yuma County, and Yuma County is willing to continue services with the City of San Luis;

NOW, THEREFORE, BE IT ORDERED by the Mayor and City Council of the City of San Luis, Arizona:

Section 1: It is deemed in the best interest of the City of San Luis ("City") and its residents that an intergovernmental agreement with Yuma County be entered into for the provision of election services.

Section 2: A true copy of said intergovernmental agreement is incorporated into this Order No. 2023-13 ("Order") as if set forth in full here as Exhibit "A" ("Intergovernmental Agreement").

Section 3: The Mayor or the Mayor's designee are hereby authorized and directed to execute this Intergovernmental Agreement on behalf of the City.

Section 4: If a conflict arises between the provisions of this Order and any other ordinance, resolution, order, regulation, or policy of the City of San Luis, the conflicting provisions are amended, superseded, and replaced, and this Order shall govern.

Section 5: If any section, subsection, paragraph, sentence clause, phrase, or portion of this Order is held to be invalid or unconstitutional by the final decision of any court of

competent jurisdiction or operation of law by binding legislation, such decision or legislation shall not affect the validity of the remaining portion of this Order.

PASSED, ADOPTED, and APPROVED by the Mayor and City Council of the City of San Luis, Yuma County, Arizona, this 13 day of December 2023.

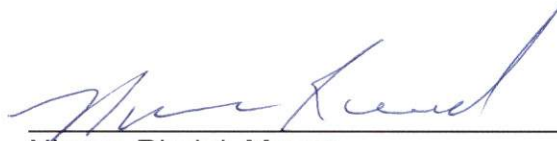

Nieves Riedel, Mayor

ATTEST:

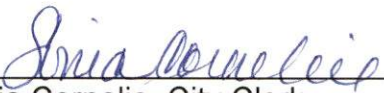

Sonia Cornelio, City Clerk

APPROVED AS TO FORM:

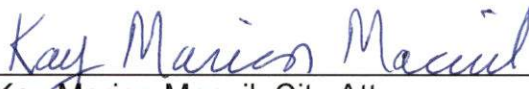

Kay Marion Macuil, City Attorney

WHEN RECORDED, MAIL TO:

**CITY OF SAN LUIS
ATTN: CITY CLERK
P.O. BOX 1170
SAN LUIS, ARIZONA 85349**

CONFORMED COPY
2024-01950 AGREEMENT
01/26/2024 11:20:40 AM Pages: 8 Fees: \$15.00
Requested By: SAN LUIS CITY CLERK'S OFFICE

Richard Colwell County Recorder, YUMA County AZ

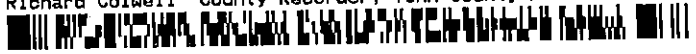

The above area is to be reserved for recording information.

CAPTION HEADING:

AGREEMENT

Intergovernmental Agreement
The County of Yuma, Yuma County Recorder
For the Provision of Elections Services



CITY OF
SAN LUIS
A R I Z O N A
WWW.SANLUISAZ.GOV

P.O. Box 1170 | 1090 E. Union Street San Luis, AZ 85349 | P: (928) 341-8520 F: (928) 341-8539

CERTIFICATION

I do hereby certify that I am a duly appointed City Clerk of the City of San Luis, Arizona, and that the attached is a true and correct copy of the **Intergovernmental Agreement – The County of Yuma, Yuma County Recorder for the Provision of Elections Services**, dated January 1, 2024, which is/are on file in the City Clerk's Office, City Hall, San Luis, Arizona.

Dated this 25th day of January 2024.

Sonia Cornelio, City Clerk

Exhibit A

Intergovernmental Agreement between

the County of Yuma,

the County Recorder

and

The City of San Luis

For the Provision of Election Services

for Calendar Years 2024-2028

INTERGOVERNMENTAL AGREEMENT
BETWEEN
THE COUNTY OF YUMA,
THE YUMA COUNTY RECORDER,
AND THE CITY OF SAN LUIS
FOR THE PROVISION OF ELECTION SERVICES
FOR CALENDAR YEARS 2024-2028

THIS AGREEMENT is entered into January 1, 2024, between the COUNTY OF YUMA (the "COUNTY"), acting by and through its duly elected governing body, the YUMA COUNTY RECORDER (the "RECORDER"), and the CITY OF SAN LUIS, (the "CITY").

I. RECITALS

1. The COUNTY owns and operates voting equipment and ballot tabulating equipment and employs certified Election Officials.
2. The CITY seeks to participate in consolidated elections and pursuant to Arizona Revised Statutes (A.R.S.) § 16-205(C), the CITY and COUNTY wish to enter into this Agreement.
3. The CITY is authorized, if it so chooses, pursuant to A.R.S. §§ 16-409 and 16-558 to conduct elections by all-mail ballot (VOTE BY MAIL).
4. The RECORDER is required by A.R.S. § 16-172 to enter into this Agreement if the CITY requests the use of County registration rolls to conduct an election, and, by seal and signature below, has resolved to enter into this Agreement.
5. The COUNTY is empowered by A.R.S. §§ 11-251 and 11-952 to enter into this Agreement and has, by appropriate Board action, determined to enter into this Agreement and has authorized the undersigned to execute this Agreement on behalf of the COUNTY.

THEREFORE, in consideration of the mutual agreements expressed herein, it is agreed as follows:

II. SCOPE

1. The COUNTY will:
 - a. Make available to the CITY support services, materials and supplies, including but not limited to: ballot cards, voting equipment, vote tallying equipment, vote center supplies, vote center personnel, vote center signature rosters, counting center personnel, early board processing personnel, and such other election materials, supplies and personnel as may be required for the conduct of the type of election called/approved by the CITY.

- b. Conduct logic and accuracy tests as required by law and publish all legal notices in connection therewith.
- c. Perform tabulation, prepare unofficial election results and transmit to the CITY or designee.
- d. Provide the RECORDER personnel necessary to effectively administer an election.
- e. At all times comply with the laws and regulations regarding the conduct of elections.
- f. Upon completion of an election, present to the CITY a detailed, itemized statement of charges incurred and billable amounts for any election type called as per the current Election Services Fee Schedule.

2. The RECORDER will:

- a. Ensure that the County registration rolls necessary for the COUNTY to conduct an election be provided to the COUNTY at least forty-five (45) days in advance of such election, with supplementation of the rolls provided at least once, as soon as possible after the twenty-ninth (29th) day preceding the election, and with further supplementation as may be necessary to conduct early voting.
- b. Handle all early balloting for the CITY, including early voting requests, early ballot mailers, on-site early voting, signature verification and other early voting supplies and services that may be necessary.
- c. FOR VOTE BY MAIL ELECTIONS: Mail ballots to every registered voter within the CITY.
- d. Upon completion of an election, present to the CITY a detailed, itemized statement of charges incurred to conduct early voting for a Vote Center OR Vote by Mail election and billable amounts for each participating CITY.
- e. Provide RECORDER personnel necessary to effectively administer early voting and other related services appropriate for type of election called/approved by the CITY.

3. The CITY will:

- a. Contact the COUNTY no later than 180 days prior to a consolidated election date notifying of intent to conduct election and advise of type of election approved by the governing body (Vote Center or Vote by Mail election).
- b. Create, translate, print and mail all publicity pamphlets.
- c. Publish all legal notices in connection with a CITY election with the exception of the logic and accuracy testing notification as described in section 1(b) of this Agreement.
- d. **FOR VOTE BY MAIL ELECTIONS:** Mail notice of election to every active registered voter for the purpose of notifying voters of the all-mail election.
- e. At all times comply with the laws and regulations regarding the conduct of elections.
- f. Reimburse the COUNTY for all charges for election materials, supplies, equipment and personnel required in direct support of the CITY election and clearly outlined in a detailed, itemized statement of charges within sixty (60) days of submittal to the CITY of a reimbursement request by the COUNTY. The CITY shall establish and maintain a budget covering the payment of all such charges.
- g. Reimburse the RECORDER for the actual additional costs incurred by the RECORDER in the preparation of any lists, electronic data compilations, early voting or Vote by Mail supplies and services under this agreement within sixty (60) days of submittal to the CITY of a reimbursement request by the RECORDER.

III. DURATION OF AGREEMENT

1. This Agreement shall be effective as of January 1, 2024 and shall remain in full force and effect for a term of FIVE (5) years from the effective date ("Initial Term"), unless terminated as otherwise provided in this Agreement. After the expiration of the Initial Term, this Agreement shall automatically renew for one (1) successive five-year term, unless (i) any party provide one-hundred and twenty (120) days' written notice to the other parties of its intent to not renew at the end of the Initial Term or (ii) this Agreement is terminated as otherwise provided in this Agreement.
2. This Agreement can be terminated at any time by any party, with or without cause, upon giving one-hundred and twenty (120) days' written notice to the other parties. Upon termination of this Agreement, all property or equipment used by the parties in the performance of their responsibilities

under this Agreement shall remain the property of the party that purchased the property or equipment.

IV. MISCELLANEOUS PROVISIONS

1. This Agreement may be canceled in accordance with the provisions A.R.S. § 38-511, regarding Conflicts of Interest.
2. The COUNTY, as a political subdivision of the State of Arizona, engaged in the performance of its mandatory statutory duties, and the RECORDER, engaged in the performance of its mandatory statutory duties, and the CITY, as a political subdivision of the State of Arizona, engaged in the performance of its mandatory statutory duties, all avow to the other that each has obtained and has in full force and effect a public entity liability policy relating to the faithful performance of duty.
3. The provisions of the Records and Disposition Schedule promulgated by Arizona State Library, Archives and Public Records, Revised October 16, 2018, pertaining to the 3-year record-retention by the RECORDER of receipts of fees are applicable to this Agreement.
4. If the parties mutually agree, claims, disputes or other matters in question may be submitted for arbitration and decided according to the Arizona Uniform Rules of Procedure for Arbitration. Demand for arbitration must be filed in writing with the other party to this Agreement.
5. All notices or demands upon any party to this Agreement, except as otherwise specified herein, shall be in writing and shall be delivered in person or sent by mail addressed as follows:

Yuma County Elections Department
102 South Main Street
Yuma, Arizona 85364

Yuma County Recorder
102 South Main Street
Yuma, Arizona 85364

City of San Luis
Office of the City Clerk
P.O. Box 1170
San Luis, AZ 85349

6. The CITY is responsible for all liability, damages or expenses involved in defending challenges to the CITY election arising out of the actions of the CITY and its officials, employees and agents.
7. E-verify requirements. To the extent applicable under A.R.S. § 41-4401, the parties warrant compliance, on behalf of themselves and any and all

subcontractors, with all federal immigration laws and regulations that relate to their employees and compliance with the E-verify requirements under A.R.S. § 23-214(A). The party's breach of the above-mentioned warranty shall be deemed a material breach of the Agreement and the non-breaching party may terminate the Agreement. The parties retain the legal right to inspect the papers of the other party to ensure that the party is complying with the above-mentioned warranty under this Agreement.

IN WITNESS WHEREOF, the parties have executed this Agreement the day and year below written, and is effective upon filing with the Office of the Yuma County Recorder.

CITY OF SAN LUIS



JENNY TORRES
Acting City Manager

Attest:

SONIA CORNELIO
City Clerk

This 13th day December, 2023.

YUMA COUNTY, ARIZONA



MARTIN PORCHAS
Chairman
Yuma County Board of Supervisors



RICHARD COLWELL
Yuma County Recorder

This 17th day January, 2024.

This 19th day JANUARY, 2024.

Attest:

IAN McGAUGHEY
Yuma County Clerk of the Board

INTERGOVERNMENTAL AGREEMENT DETERMINATION
BETWEEN
THE COUNTY OF YUMA,
THE YUMA COUNTY RECORDER
AND THE CITY OF SAN LUIS
FOR THE PROVISION OF ELECTION SERVICES
FOR CALENDAR YEARS 2024-2028

Pursuant to Arizona Revised Statutes § 11-952, the foregoing Agreement has been submitted to the Administrator for the CITY OF SAN LUIS Arizona. The undersigned has determined that this Agreement is in proper form and is within the powers and authority granted under the laws of the State of Arizona to the CITY OF SAN LUIS.

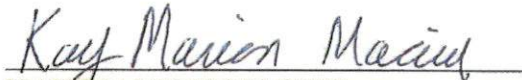
KAY MARION MACUIL
City of San Luis Attorney

INTERGOVERNMENTAL AGREEMENT DETERMINATION
BETWEEN
THE COUNTY OF YUMA,
THE YUMA COUNTY RECORDER
AND THE CITY OF SAN LUIS
FOR THE PROVISION OF ELECTION SERVICES
FOR CALENDAR YEARS 2024-2028

Pursuant to Arizona Revised Statutes § 11-952, the foregoing Agreement has been submitted to the undersigned Attorney for the County of Yuma, Arizona. The undersigned has determined that this Agreement is in proper form and is within the powers and authority granted under the laws of the State of Arizona to the County of Yuma.

JON R. SMITH
Yuma County Attorney



AGENDA ITEM REVIEW FORM

Regular City Council Meeting

7. B.

Meeting Date: 04/10/2024

Department Head: Jenny Torres, Acting City Manager, Administration

Submitted By: Edgar Juarez, Facilities Project Coordinator, Administration, Facilities

Action Requested: Motion

ITEM:

Discussion and possible action on any and all matters regarding the acceptance and award of a construction contract to DWD Construction for the Finance Wing Reconfiguration Project at City Hall. **(Edgar Juarez, Facilities Project Coordinator)**

SUMMARY:

The Division of Facilities is seeking Council approval to accept and award a construction contract to DWD Construction, 13461 S Ave B, Yuma, AZ 85365, for the Finance Wing Reconfiguration Project at City Hall. DWD Construction was the only bidder.

The project consists of general construction, plumbing, heating, ventilation, air conditioning, and electrical, as shown in the plans and specifications as prepared by Edais Engineering, Inc. This project is broken down into three sections. The first section involves the addition of three enclosed offices and the removal of the wall going into the old HR section. The second section involves the expansion of the conference room, and the third section involves the addition of a restroom/storage.

The Facilities Division is seeking Council approval of Construction Services from DWD Construction and the contract for this project for the amount of \$100,882.02 as permitted under the city's procurement code section 3.05.030 Bidding.

RECOMMENDATION / SUGGESTED MOTION:

I MOVE TO AWARD THE CONTRACT TO DWD CONSTRUCTION IN AN AMOUNT NOT TO EXCEED \$100,882.02.

Fiscal Impact

IS THERE FISCAL IMPACT ASSOCIATED WITH THIS ITEM:	Yes
CITY/STATE/FEDERAL FUNDS:	City
TOTAL:	\$100,882.02
BUDGETED AMOUNT:	\$80,000
AVAILABLE AMOUNT TO TRANSFER:	N/A
ACCT NAME & GL#/REMAINING BALANCE BEFORE PURCHASE:	City Hall Reconfiguration for East and West Wings GL#100-999-90015
FISCAL IMPACT STATEMENT (IF THIS IS A BUDGET TRANSFER, YOU MUST ATTACH THE BUDGET ADJUSTMENT FORM):	

The adopted budget for this project is \$80,000. The total cost for this project is \$110,882.02, which includes \$10,000 for the design. The remaining \$30,882.02 will be used from projects that will not be completed prior to June 30th, 2024, which was approved at the Regular Council meeting held March 27, 2024.

Attachments

Contract

Bid Opening Results - Clerks Office

DWD Construction Bid Documents

2024 RFB Documents Finance Wing Reconfiguration Project

Addendum #1 Finance Wing Reconfiguration Project

CONSTRUCTION CONTRACT

This construction contract ("Contract") made this ____ day of April 2024, between:

DWD Construction
13461 S Avenue B
Yuma, Arizona 85365, a sole
proprietorship of Nathaniel David
Darnell, Jr., doing business as D W D
Construction ("Contractor" or
"Vendor") and

City of San Luis
1090 E Union St. (Physical Address)
P.O. Box 3750 (Mailing Address)
San Luis, Arizona 85349, a municipal
corporation organized under the laws
of Arizona ("City" or "City of San Luis")

SECTION ONE. CONTRACT DOCUMENTS

The Contract documents include and are, by this reference, made a part of this Contract to the same extent as if fully set forth again in full here:

- the Contractor's Proposal submitted to the City, including the Bonds required by the R.F.B., documents or submittals required by the R.F.B., Certificates of Insurance and Endorsements required by the R.F.B., Change Orders, if any,
- the advertisement for bids,
- the Request for Bids ("R.F.B.") for Construction of a Municipal Complex Remodel and Reconfiguration of a portion of the Finance Wing of the administration building located at 1090 E. Union Street, San Luis, Arizona ("Project"),
- the Addenda to the RFB,
- the Plans and Specifications for the Project by Edais Engineering, and
- Part 100 General Conditions of the 2015 Maricopa Association of Governments Uniform Standard Specifications for Public Works Construction, as adopted by the City of San Luis as its Public Works Standards ("Part 100"), shall apply to this Contract. In the event of a conflict between Part 100 and the R.F.B., the terms and conditions of the R.F.B. shall control. (Note: all references to Engineer in Part 100 shall mean the San Luis Facilities Project Coordinator.)

SECTION TWO. DESCRIPTION OF WORK

The Contractor will perform the work described in the Request For Bids for the construction of a municipal complex remodel and reconfiguration of a portion of the Finance Wing (the west wing) of the San Luis City Hall located at 1090 E. Union Street, San Luis, Arizona ("Project"). The City has divided the Project into three Sections.

This Contract shall be for all Sections 1, 2, and 3 as set forth in the Proposal submitted by the Contractor. The Contractor and City shall communicate and coordinate activities so as to minimize disruption of the City's operations.

SECTION THREE. THE CONTRACT PRICE

The City shall pay the Contractor the fixed sum of \$100,882.02 (the "Contract Price") for the work to be performed under this Contract, subject to additions and deductions pursuant to change orders agreed upon in writing by the parties.

SECTION FOUR. PAYMENT SCHEDULE

The Contract Price shall be paid upon completion of the work for each Section for the Sections described above. The payment is to be made within 30 days after billing.

SECTION FIVE. START AND COMPLETION OF WORK

The work to be performed under this Contract shall be commenced on approximately **April 11, 2024**, as long as any required building permits are received and any agreed-upon funds are paid to the Contractor. The Project shall be completed by approximately **June 20, 2024**, subject to permissible delays as defined in this Contract. Substantial commencement of the work shall be deemed to occur when the Contractor first supplies workers to the Project who actually commence construction operations.

SECTION SIX. PERMITS AND TESTS

Unless otherwise agreed in writing by the parties, the City shall be responsible for the cost of all permits required for the Project. The City shall also be responsible for the cost of any testing or inspection of the Project which may be required.

SECTION SEVEN. PERMISSIBLE DELAYS

- A. The Contractor shall be excused from any delay in the completion of the work to be performed under this Contract caused by acts of public bodies or inspectors (unless related to defects in the Contractor's performance), extra work, or changes requested by City, failure by City to make payments promptly, or other circumstances or contingencies unforeseen by Contractor and beyond Contractor's reasonable control.
- B. Force Majeure Event. A "Force Majeure Event" means any action or event that occurs outside the City's and Contractor's reasonable control and without the fault or negligence of either party that prevents, prohibits, or materially interferes with the ability to progress on the Project. Examples that might have this effect on the Project are natural disasters, man-made disasters, a governmental enactment that prohibits or materially interferes with the Project, public health emergencies, biological or chemical contamination, interruption in

electric power, or other events beyond the control of the parties. In a *Force Majeure* Event that impacts the Project's schedule, the Contractor shall only be entitled to an extension of time and shall not be entitled to any compensation or any increase in the Contract compensation, except to the extent that a *Force Majeure* Event causes damage to the Project work in place. The costs for damage to the Project's work in place may be recoverable by insurance applicable to the Project. However, if the costs to correct the work damaged by a *Force Majeure* Event are not covered by insurance, then the Contractor shall be entitled to recover only its actual direct costs for damages to work in place. Actual direct costs for purposes of this section are limited to the actual direct costs for performing the work as opposed to indirect costs and expenses, such as loss of use, loss of profits, consequential damages, cost of capital, loss of wages, pain and suffering, loss of productivity, financing charges, increased or extended office overhead, loss of interest on retainage, loss of interest on anticipated income, loss of bonding capacity, loss of use, decrease in value, or interest on debt financing. A *Force Majeure* Event shall not release the Parties from their obligations under this Contract, nor shall it be construed to discharge any surety. In the event of a *Force Majeure* Event that impacts the Project's schedule, the Contractor shall only be entitled to an extension of time and shall not be entitled to any compensation or any increase in the Contract compensation, except to the extent that a *Force Majeure* Event causes damage to Project work in place. No recovery on any basis shall be allowed unless the CONTRACTOR has satisfied all the following conditions:

- The Contractor has given immediate written notice within four (4) calendar days of the *Force Majeure* Event and documented the anticipated impact on the Contractor's ability to perform. The Contractor shall provide updates to its assessment of the impacts on its ability to perform under the Contract on an ongoing basis at appropriate intervals.
- The Contractor is not in default under the Contract.
- The Contractor has documented all its direct costs for the City and any insurance carrier (for example, photographs, videos, receipts, and other credible documentation).
- The Contractor has used reasonable and diligent efforts to avoid and minimize delays, regardless of cause.
- The Contractor has cooperated with the City to mitigate the impact of any delays encountered by the Contractor that would entitle it to an extension of time.

SECTION EIGHT. EXTRA WORK

No extra work is to be performed without a written change order approved by the City. Prior to approval of such change order, the Contractor shall provide an

estimate of cost for such extra work, and at no time shall the cost for such extra work exceed said estimate.

SECTION NINE. RELEASE OF MECHANICS' LIENS

Upon satisfactory payment being made for any portion of the work performed, Contractor shall, prior to any further payment being made, furnish to City a full, complete, and unconditional release from any claim or mechanic's lien pursuant to A.R.S. 33-993 for that portion of the work for which payment has been made.

SECTION TEN. INDEMNIFICATION AND INSURANCE

Contractor or subcontractors or both shall procure and maintain until all of their obligations have been discharged, including any warranty periods under this Contract are satisfied, insurance against claims for injury to persons or damage to property which may arise from or in connection with the performance of the work hereunder by the Contractor, his agents, representatives, employees, or subcontractors.

The insurance requirements herein are minimum requirements for the Contract and in no way limit the indemnity covenants contained in the Contract.

The City in no way warrants that the minimum limits contained herein are sufficient to protect the Contractor from liabilities that might arise out of the performance of the work under this Contract by the Contractor, his agents, representatives, employees, or subcontractors. The Contractor is free to purchase such additional insurance as necessary.

Additional Insurance Requirements: The policies shall include, or be endorsed to include, the following provisions:

1. On insurance policies where the City of San Luis is named as an additional insured, the City of San Luis shall be an additional insured to the full limits of liability purchased by the Contractor even if those limits of liability are in excess of those required by this Contract.

Additional Insured:

City of San Luis
1090 E Union Street
P.O. Box 1170
San Luis, Arizona 85349

2. The Contractor's insurance coverage shall be primary insurance and non-contributory with respect to all other available sources.

All certificates required by this Contract shall be emailed directly to msabori@sanluisaz.gov and ejuarez@sanluisaz.gov. The Project shall be noted on

the certificate of insurance as the Finance Wing Reconfiguration Project at San Luis City Hall. The City reserves the right to require complete, certified copies of all insurance policies required by this Contract at any time. Any Renewal of insurance certificates with endorsements will need to be emailed to the above emails at least two weeks prior to expiration attention, "Finance Wing Reconfiguration Project at San Luis City Hall." The City reserves the right to require complete, certified copies of all insurance policies required by this Contract at any time. Any Renewal of insurance certificates with endorsements will need to be emailed to msabori@sanluisaz.gov and ejuarez@sanluisaz.gov at least two weeks prior to expiration.

Notice of Cancellation: With the exception of a ten (10) day notice of cancellation for nonpayment of premium, any changes to the insurance policies above shall require thirty (30) days written notice.

Acceptability of Insurers: Insurance is to be placed with insurers with a current A.M. Best's rating of no less than A-VII unless otherwise approved by the City of San Luis Risk Management Division.

Verification of Coverage: The Contractor shall furnish the City with certificates of insurance (ACORD form or equivalent approved by the City) as required by this Contract. The certificates for each insurance policy are to be signed by a person authorized by that insurer to bind coverage on its behalf.

All certificates and any required endorsements are to be received and approved by the City before work commences. Each insurance policy required by this Contract must be in effect at or prior to the commencement of work under this Contract and remain in effect for the duration of the Contract. Failure to maintain the insurance policies as required by this Contract or to provide evidence of renewal is a material breach of the Contract.

Insurance Limit Requirements – The Contractor shall provide coverage with limits of liability not less than those stated below. An excess liability policy or umbrella liability policy may be used to meet the minimum liability requirements provided that the coverage is written on a following form basis.

Commercial General Liability – Occurrence Form:

The policy shall include bodily injury, property damage, personal injury, and broad-form contractual liability coverage.

- General Aggregate \$ 2,000,000
- Products-Completed Operations Aggregate \$ 1,000,000 (if applicable)
- Personal and Advertising Injury \$ 1,000,000 (if applicable)
- Each Occurrence \$ 1,000,000

- Fire Legal Liability (Damage to Rented Premises) \$ 100,000 (if applicable)

The policy shall be endorsed to include the following additional insured language:
“The City of San Luis shall be named as an additional insured with respect to liability arising out of the activities performed by, or on behalf of, the Vendor.”

Business Automobile Liability: Bodily Injury and Property Damage for any owned, hired, and/or non-owned vehicles used in the performance of this Contract.

Combined Single Limit (C.S.L.) \$ 1,000,000

The policy shall be endorsed to include the following additional insured language:
“The City of San Luis shall be named as an additional insured with respect to liability arising out of the activities performed by, or on behalf of the Vendor.”

Worker’s Compensation and Employer’s Liability:

Workers’ Compensation Statutory Employer’s Liability

Each Accident - \$ 1,000,000

Disease – each employee - \$ 1,000,000

Disease – policy limit - \$ 1,000,000

The policy shall contain a waiver of subrogation against the City for losses arising from work performed by or on behalf of the Vendor.

All insurance required pursuant to this Contract must be written by an insurance company authorized to do business in the State of Arizona, to be evidenced by a Certificate of Authority as defined in A.R.S. § 20-217, a copy of which certificate is to be attached to each applicable bond or binder.

Prior to commencing work under this Contract, the Contractor shall provide the City with evidence that it is either a “self-insured employer” or a “carrier-insured employer” for Workers’ Compensation as required by A.R.S. § 23-901 et seq. or that it employs no persons subject to the requirement for such coverage.

SECTION ELEVEN. MISCELLANEOUS

- Survival.** All Contractor’s representations, warranties, indemnity, and hold obligations shall survive the expiration or earlier termination of this Contract.
- Safety.** The Contractor expressly agrees that it shall be solely responsible for supervising its employees: that it shall comply with all rules, regulations, orders, standards, and interpretations promulgated pursuant to the federal Occupational Safety and Health Act (known as OSHA), regulation under OSHA and any occupational safety and health act of Arizona including but not limited to training provisions of personal protective equipment; adherence to all

appropriate lockout-tagout procedures and providing all notices, safety data sheets, etc., as required by the right-to-know standard.

- C. Independent Contractor. The parties intend that this Contract will create an independent contractor relationship and not an employer-employee relationship. Neither does this Contract create an agency relationship. The City of San Luis is interested only in the results to be achieved. The conduct and control of the performance of the services contemplated in this Contract will be solely with the Contractor.
- D. Waiver. No delay in exercising any right or remedy shall constitute a waiver thereof. No waiver by the Contractor or City of the breach of any covenant of this Contract shall be construed as a waiver of any preceding or succeeding breach of the same or any other covenant or condition of this Contract.
- E. Attorneys' Fees. If any party finds it necessary to bring any action at law or other proceeding, including arbitration, against the other party to enforce any of the terms, covenants, or conditions hereof, or by reason of any breach or default of this Contract, the party prevailing in any such action or other proceeding shall be paid all reasonable costs, expert fees, and reasonable attorneys' fees by the other party. If the said prevailing party secures any judgment, all such costs, experts' fees, and attorneys' fees shall be included in the judgment. The attorneys' fees are to be set by the court and not by jury.
- F. Counterparts. This Contract may be executed in one or more counterparts, each of which shall be deemed an original, but all of which together shall constitute one and the same instrument. The signature pages from one or more counterparts may be removed from such counterparts, and such signature pages all attached to a single instrument so that the signature of all parties may be physically attached to a single document.
- G. Headings. The descriptive headings of the paragraphs of this Contract are inserted for convenience only. They shall not control or affect the meaning or construction of any of the provisions of this Contract.
- H. Further Acts. Each of the parties hereto shall execute and deliver all such documents and perform all such acts as reasonably necessary, from time to time, to carry out the matters contemplated by this Contract.
- I. Time of the Essence. Time is of the essence of this Contract. The Contractor agrees to use the utmost diligence and dispatch to complete the Project speedily and to have all the work specified in this Contract entirely completed on or before June 20, 2024.
- J. No Partnership and Third Parties. This Contract does not intend to create and nothing contained in this Contract shall create any partnership, joint venture, or other similar arrangement between Contractor or City. No term or provision of this Contract is intended to, or shall, be for the benefit of any person, firm,

organization, or corporation not a party to this Contract, and no such other person, firm, organization, or corporation shall have any right or cause of action under this Contract.

- K. Entire Agreement. This Contract constitutes the entire agreement between the parties hereto pertaining to the subject matter hereof. All prior and contemporaneous agreements, representations, and understandings of the parties, oral or written, are hereby superseded and merged into this Contract.
- L. Amendment. No change or additions are to be made to this Contract except by a written amendment executed by the parties hereto.
- M. Governing Law. This Contract is entered into in Arizona and shall be construed and interpreted under the laws of the State of Arizona.
- N. A.R.S. § 38-511 This Contract is subject to the provisions of A.R.S. § 38 511.
- O. Venue. Any legal action relating to this Contract shall be brought in either the Yuma County Superior Court or in the United States District Court for the District of Arizona at the election of the plaintiff in such legal action, provided, however, that nothing in this paragraph will be deemed to have authorized the bringing of any legal action in a court which does not otherwise have jurisdiction to adjudicate the legal action.
- P. Severability. Every provision of this Contract is and will be construed to be a separate and independent covenant. If any provision of this Contract or the application of the same is, to any extent is found to be invalid or unenforceable by a court of competent jurisdiction or controlling legislation, then the remainder of this Contract or the application of that provision to circumstances other than those to which it is invalid or unenforceable, will not be affected by that invalidity or unenforceability, and each provision of this Contract will be valid and will be enforced to the extent permitted by the law, and the parties will negotiate in good faith for such amendments of this Contract which may be necessary to achieve its intent, notwithstanding such invalidity or unenforceability.
- Q. No Personal Liability. No member, officer, elected official, or employee of the City shall be personally liable to Contractor, or any successor or assignee, (a) in the event of any default or breach by the City, (b) for any amount which may become due to Contractor or its successor or assign, or (c) pursuant to any obligation of the City under the terms of this Contract.
- R. Employment Eligibility. The Contractor hereby warrants and shall require its subcontractors to warrant that it is in compliance with all federal immigration laws and regulations that relate to its employees and with A.R.S. § 23-214 relating to verification of employment eligibility. A breach of this warranty shall be deemed a material breach of the Contract and is subject to penalties up to and including termination of this Contract. City retains the legal right to inspect

the papers of Contractor and any contractor or subcontractor employee of Contractor to ensure that Contractor and any of its contractors or subcontractors are compliant with this warranty.

- S. No Forced Labor of the Ethnic Uyghurs. Under A.R.S. § 35-394, the Contractor certifies, to the extent permitted by law, that it does not currently and agrees for the duration of this Contract that it will not use:
1. The forced labor of ethnic Uyghurs in the People's Republic of China.
 2. Any goods or services produced by the forced labor of ethnic Uyghurs in the People's Republic of China.
 3. Any contractors, subcontractors, or suppliers that use the forced labor or any goods or services produced by the forced labor of ethnic Uyghurs in the People's Republic of China.
- T. No Boycott. The Contractor hereby certifies to the extent permitted by law that the Contractor is not currently engaged in and agrees for the duration of the Contract to not engage in a boycott of goods or services from Israel.
- U. Obey All Laws. The Contractor certifies that it will comply with all federal, state, and local statutes, laws, ordinances, rules, and regulations. The Contractor will comply with the Americans with Disabilities Act (ADA) and will indemnify the City for any costs, including but not limited to damages, attorney's fees, and staff time in any action or proceeding brought alleging violation of the A.D.A. The Contractor will not discriminate against any person on the basis of race, religion, color, age, sex, or national origin in the performance of this Contract and must comply with the terms and intent of Title VII of the Civil Rights Act of 1964, P.L. 88-354 (1964). In addition, the Contractor must include similar requirements of subcontractors in any contracts entered into for the performance of the Contractor's obligations under this Contract. The Contractor agrees not to participate in or cooperate with an international boycott, as defined in Section 999 (b)(3) and (4) of the Internal Revenue Code of 1954, as amended, or engage in conduct declared to be unlawful by Arizona state law. In addition, the Contractor must include similar requirements of all subcontractors in contracts entered for the performance of the Contractor's obligations under this Contract.
- V. Assignment. The rights of each party under this Contract are personal to that party. They may not be assigned or transferred to any other person, firm, corporation, or other entity without the prior, express, and written consent of the other party.

W. Authority. The undersigned represent to each other that they have full power and authority to enter into this Contract and that all necessary actions have been taken to give full force and effect to this Contract.

IN WITNESS WHEREOF, the original AGREEMENT will be filed with the City of San Luis City Clerk.

The CONTRACTOR agrees that this AGREEMENT, as awarded, is for the stated work and understands that payment for the total work will be made on the basis of the indicated amount, as bid in the PROPOSAL. The OWNER shall pay to the CONTRACTOR, as full consideration for the faithful performance of the AGREEMENT, subject to any additions or deductions as provided in the PROJECT documents, the sum of \$286,859.67.

The Parties have executed this AGREEMENT in Yuma County, Arizona.

City of San Luis, Arizona

Nieves Riedel, Mayor

Date: _____

Attest:

Approved As to Form

Sonia Cornelio, City Clerk

Kay Marion Macuil, City Attorney

DWD Construction

Shane Darnell
For Nathaniel David Darnell, Jr.
Proprietor
Registrar of Contractors #248137

Date: _____

Witness:

Signature

Print Name: _____

City of San Luis
Finance Wing Reconfiguration Project
BID PROPOSAL
Bid Submittal Form

Bid Schedule

Section 1: Addition of 3 Enclosed Offices					
Bid Item	Item Description	Estimated Quantities	Unit	Unit Price	Total
1	Labor: Demolition of existing walls, preparation of surfaces, and installation of new improvements.	1	Lump Sum		19,000.00
2	All materials and equipment	1	Lump Sum		17,000.00
3	Taxes and Fees	1	Lump Sum		6,800.00
Subtotal					42,800.00
5% Contingency					2,140.00
Total					44,940.00

Section 2: Expansion of Conference Room					
Bid Item	Item Description	Estimated Quantities	Unit	Unit Price	Total
1	Labor: Demolition of existing walls, preparation of surfaces, and installation of new improvements.	1	Lump Sum		5,778.12
2	All materials and equipment	1	Lump Sum		3,500.00
3	Taxes and Fees	1	Lump Sum		3,000.00
Subtotal					12,278.12
5% Contingency					613.90
Total					12,892.02

Section 3: Addition of Restroom					
Bid Item	Item Description	Estimated Quantities	Unit	Unit Price	Total
1	Labor: Demolition of existing walls, preparation of surfaces, and installation of new improvements.	1	Lump Sum		18,000.00
2	All materials and equipment	1	Lump Sum		17,000.00
3	Taxes and Fees	1	Lump Sum		6,000.00
Subtotal					41,000.00
5% Contingency					2,050.00
Total					43,050.00

GRAND

TOTAL 100,882.02 (Bidder understands that City reserves the right to award a Contract for each section separately and may award a contract for one, two, or all sections in its discretion and may award different Sections to different Bidders.)

THIS PROPOSAL IS SUBMITTED BY DWD CONSTRUCTION

A corporation organized under the laws of the State of _____,

or a partnership consisting of _____,

or individual trading as DWD CONSTRUCTION

of the City of YUMA, AZ (City, State) and is the holder of Arizona State Contractor's license(s): ROC 248137 (type) Classification KB-01 License No. 248137.

The bidder hereby certifies that as of the below date, the bond amount posted with the Arizona Registrar of Contractors is \$ 24,000 and the Bidder's actual volume of work has not exceeded the contemplated gross volume pursuant to Arizona Administrative Code, Title 4 Chapter 9 [Authority: ARS 32-1101 et seq.]

Respectfully submitted,

Bidders Firm DWD CONSTRUCTION

Address 13461 S. Avenue B

City, State, ZIP Yuma AZ 85365

By [Signature] 3/6/24
[Signature] [Date]

Name SHANE DARNELL

Title MANAGER

ATTEST:
[If Bidder is an individual]

Witness: [Signature] 3/6/24
[Signature] [Date]

ESTIMATE

DWD construction
13461 S AVE B
Yuma, AZ 85365

SHANE.DWDCONSTRUCTION@OU
TLOOK.COM
+1 (928) 581-1011

WEST WING

Bill to
WEST WING

Ship to
WEST WING

Estimate details

Estimate no.: 1355
Estimate date: 03/05/2024

#	Date	Product or service	SKU	Qty	Rate	Amount
1.		1000 DEMO		1	\$3,570.00	\$3,570.00
2.		1000 FRAMING		1	\$8,840.00	\$8,840.00
3.		1000 DRYWALL TAPE AND TEXTURE		1	\$6,500.00	\$6,500.00
4.		1000 T-BAR		1	\$3,750.00	\$3,750.00
5.		1000 ELECTRICAL		1	\$11,500.00	\$11,500.00
6.		1000 INSULATION		1	\$2,100.00	\$2,100.00
7.		1000 HVAC		1	\$5,128.00	\$5,128.00
8.		1000 PLUMBING		1	\$7,800.00	\$7,800.00
9.		1000 DOORS AND WINDOWS		1	\$14,300.00	\$14,300.00
10.		1000 TILE AND FLOORING		1	\$5,750.00	\$5,750.00

11.	1000 PAINT	1	\$4,880.00	\$4,880.00
12.	101 PROFIT AND OVER HEAD	1	\$22,235.40	\$22,235.40
13.	SUB FOR PROJECT CONFIGURATION AIR/HVAC DESERT INSULATION LLC/ INSULATION NU-WAVE INNOVATIONSLLC/ ELECTRICAL DESERT DOORS/ DOORS SUPREME PLUMBING/ PLUMBING			\$0.00

Subtotal \$96,353.40

Sales tax \$4,528.62

Total \$100,882.02

STATUTORY PROPOSAL BOND
PURSUANT TO TITLE 34, CHAPTER 2, ARTICLE 1
OF THE ARIZONA REVISED STATUTES (Penalty of this bond must not be
less than 100% of the Proposal amount)

KNOW ALL MEN BY THESE PRESENTS:

That _____ we, DWD Construction (hereinafter referred to as "Principal") as Principal, and Philadelphia Indemnity Insurance Company (hereinafter called the Surety) a corporation organized and existing under the laws of the State of Pennsylvania with its principal offices in the County of _____, as Surety, are held and firmly bound unto Yuma County (hereinafter "Obligee") in the amount of Dollars (\$100882.02) for the payment whereof, the said Principal and Surety bind themselves, and their heirs, administrators, successors and assigns, jointly and severally, firmly by these presents.

WHEREAS, the said Principal has submitted a Proposal for: CITY OF SAN LUIS FINANCE WING RECONFIGURATION PROJECT AT SAN LUIS CITY HALL

NOW, THEREFORE, if the Obligee shall accept the proposal of the Principal and the Principal shall enter into a contract with the Obligee in accordance with the terms of the proposal and give the Bonds and Certificates of Insurance as specified in the Standard Specifications with good and sufficient Surety for the faithful performance of the Contract and for the prompt payment of labor and material furnished in the prosecution of the contract, or in the event of the failure of the Principal to enter into such contract and give the Bonds and Certificates of Insurance, if the Principal pays to the Obligee the difference not to exceed the penalty of the bond between the amount specified in the Proposal and such larger amount for which the Obligee may in good faith contract with another party to perform the work covered by the Proposal, then this obligation is void. Otherwise, it remains in full force and effect provided, however, that this bond is executed pursuant to the provisions of Section 34-201, Arizona Revised Statutes, and all liabilities on this bond shall be determined in accordance with the provisions of the section to the extent as if it were copied at length herein.

Witness our hands this 5th day of MARCH, 20 24 .

PRINCIPAL SEAL

By: _____

SURETY SEAL

AGENCY OF RECORD



FAITHFUL PERFORMANCE BOND

Whereas, CITY OF SAN LUIS , State of ARIZONA, and DWD CONSTRUCTION (hereinafter designated as Principal") have entered into an agreement whereby principal agrees to install and complete certain designated public improvements, which said agreement, dated, 3/5/2024 , and identified as project WHEREA, CITY OF SAN LUIS FINANCE WING RECONFIGURATION PROJECT AT SAN LUIS CITY HALL , is hereby referred to and made a part hereof; and

Whereas, said Principal is required under the terms of said agreement to furnish a bond for the faithful performance of said agreement.

Now, therefore, we, the Principal and PHILADELPHIA INDEMNITY INSURANCE COMPANY, as surety, are held and firmly bound unto the CITY OF SAN LUIS WEST WING(hereinafter called ("City")), in the penal sum of. (\$ 100,882.02) lawful money of the United States, for the payment of which sum well and truly to be made, we bind ourselves, our heirs, successors, executors and administrators, jointly and severally, firmly by these presents.

The condition of this obligation is such that if the above-bounded Principal, his or its heirs, executors, administrators, successors or assigns, shall in all things stand to and abide by, and well and truly keep and perform the covenants, conditions and provisions in the said agreement and any alteration thereof made as therein provided, on his or their part, to be kept and performed at the time and in the manner therein specified, and in all respects according to their true intent and meaning, and shall indemnify and save harmless CITY OF SAN LUYIS WEST WING, its officers, agents and employees, as therein stipulated, then this obligation shall become null and void; otherwise it shall be and remain in full force and effect.

As a part of the obligation secured hereby and in addition to the face amount specified therefor, there shall be included costs and reasonable expenses and fees, including reasonable attorney's fees, incurred City in successfully enforcing such obligation, all to be taxed as costs and included in any judgment rendered.

The surety hereby stipulates and agrees that no change, extension of time, alteration or addition to the terms of the agreement or to the work to be performed thereunder or the specifications accompanying the same shall in anywise affect its obligations on this bond, and it does hereby waive notice of any such change, extension of time, alteration or addition to the terms of the agreement or to the work or to the specifications.

In witness whereof, this instrument has been duly executed by the principal and surety above named, on

5th day of MARCH, 20 24.

PRINCIPAL SEAL

By: _____

SURETY SEAL

AGENCY OF RECORD



ENGINEERING CONSULTANTS SECTION
NON-COLLUSION AFFIDAVIT

Project Name: Finance wing Reconfiguration
Project No. _____

NON-COLLUSION AFFIDAVIT

State of Arizona)) ss
County of _____)

DWD construction / Shane Darnell
(Affiant)

the manager
(Title)

of DWD construction
(Contractor)

the persons, corporation, or company who makes the accompanying Proposal, having first been duly sworn, deposes and says:

That such Proposal is genuine and not sham or collusive, nor made in the interest or behalf of any person not herein named, and that the Bidder has not directly or indirectly induced or solicited any other Bidder to put in a sham bid, or any other person, firm, or corporation to refrain from bidding, and that the Bidder has not in any manner sought by collusion to secure for itself an advantage over any other Bidder.

[Signature]
(Signature)

manager
(Title)

Subscribed and sworn to before me this

March Day of 5, 2020
[Signature]

Signature of Notary Public in and for
the County of Yuma



Yuma Carpets
aarons@yumacarpets.com
(928)-328-1045

Supreme Plumbing Solutions
supremeplumbingsolutions@outlook.com
(928)-920-5683

Nu-Wave Innovations LLC
Work Phone: (928) 580-4066
Work Email: josh@nu-waveinnovations.com

Lighthouse Painting
lhousepaint@aol.com
(928)-627-5871

Configuration Air LLC
o.configurationair@gmail.com
(928)-726-9886

Desert Insulation LLC
desertinsulationllc@gmail.com
(928) 941-2272

Desert Door & Building Supply
sales@desertbuilding.com
(928)783-8333

Carlson Glass Inc
jeff@carlsonglass.com
(520)661-6866

Benji Drywall LLC
benjidrywall_llc@hotmail.com
(928)446-0608



City of San Luis

Department of Facilities

CITY OF SAN LUIS

FINANCE WING RECONFIGURATION PROJECT AT CITY HALL

Bid Addendum #1

This Addendum Changes/Updates the following:

Date Issued: 2/22/24

To: **All prospective bidders**

Addition 1: Any surface where walls will be removed must be replaced with carpet to match existing carpet color and height. Replacement of the carpet area must be kept to a minimum. We are replacing the flooring soon; however, we want to prevent tripping hazards from this construction until new flooring is installed. This will be required for the two walls that will be removed. Section 1: wall demolition going into old HR section. Section 2: conference room expansion where wall will be removed.

Addition 2: City staff will be responsible for moving partitions, cubicles, desks, and paperwork prior to construction. After construction, city staff is responsible for returning materials.

Addition 3: Colors for walls and trim will be provided to the lowest responsible bidder. Two different color tones: 1 for walls, and 1 for trims.

Addition 4: New offices shall have their own light switches and work independently.

Addition 5: Wall going into old HR's section that will be removed, must be removed as later as possible in the project. This will serve as a separation from construction area to existing area.

Question 1: Will any fire sprinklers need to be relocated?

Response 1: Fire sprinklers will not need to be replaced or relocated.

Question 2: Can existing door frames and doors be used in new locations? This will save some cost.

Response 2: Yes, doors and door frames can be utilized to save cost if doors swing in the same direction and follow code. Doors can be re-purposed in the following order: (See diagram below)

- Section 1: Existing office door that will be sealed (West wall of office) relocated to north wall of same office.
- Section 1: Door of wall that will be removed to be relocated to one of the three new offices.
- Section 3: Door in current office to be relocated in new storage room.

(3) New doors will be needed at: 2 new offices at section 1 and restroom door at section 3. Contractor to match door by Oshkosh Door, Oshkosh Series. If unable to find the exact door, the new door must be approved by City staff/coordinator.



City of San Luis

Department of Facilities

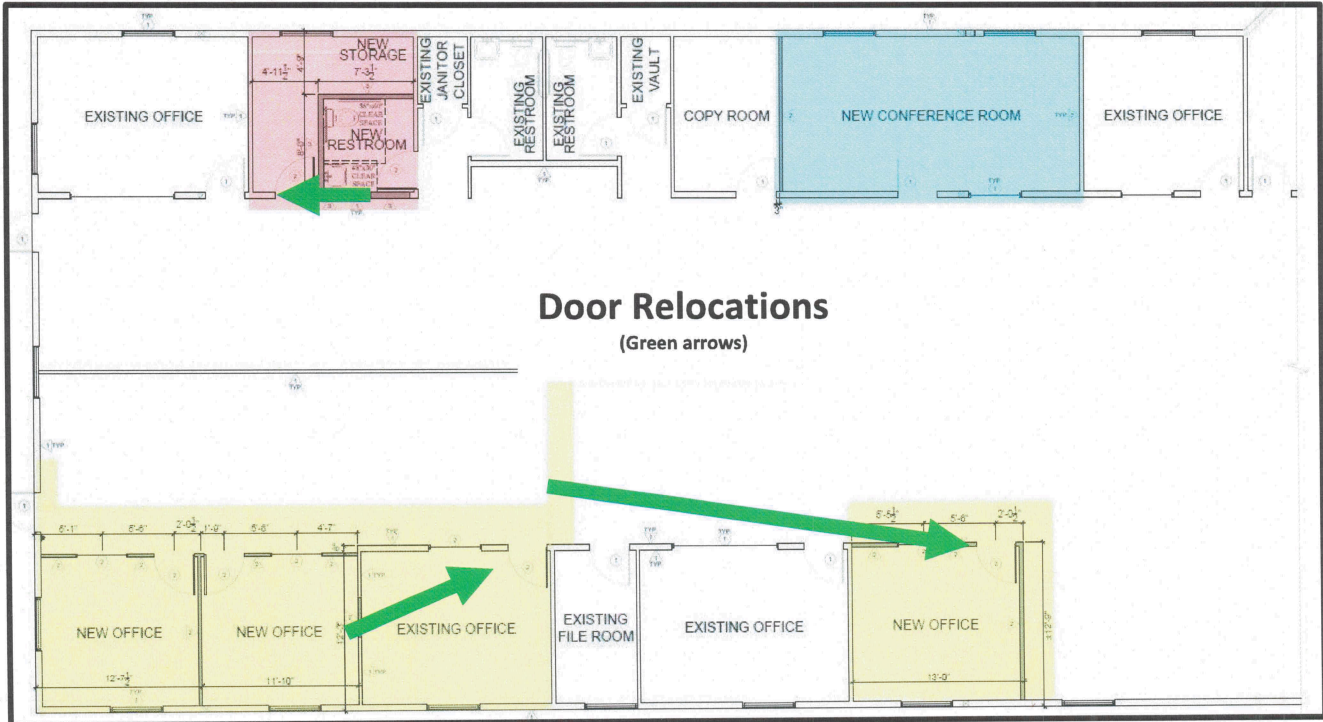

Question 3: Will there be someone present after hours to open, close, and supervise?

Response 3: Assigned city staff will be at location only to open facility. There will be no physical supervision other than remote camera access by City staff. On call staff will be available over the phone for any questions. The contractor is responsible for closing facilities once they are done with daily work.

Question 4: Will we need to isolate electricity where partitioners will be removed?

Response 4: Practitioners for this project do not have any electricity going through them. Any reconfigurations must follow Edais Engineering plans.

This Addendum is incorporated into the contract documents. Please acknowledge receipt of this addendum as part of the submittal of bid. All other terms and conditions remain the same.

Edgar Juarez
Facilities Project Coordinator

PRODUCER Stampede Insurance Services, Inc. N. Altadena Drive, Ste. 205 Pasadena, CA 91107	THIS CERTIFICATE IS ISSUED AS A MATTER OF INFORMATION ONLY AND CONFERS NO RIGHTS UPON THE CERTIFICATE HOLDER. THIS CERTIFICATE DOES NOT AMEND, EXTEND OR ALTER THE COVERAGE AFFORDED BY THE POLICIES BELOW.		
	INSURERS AFFORDING COVERAGE	NAIC #	
INSURED W D Construction Nathaniel Darnell S. Avenue B Yuma, AZ 85365	INSURER A:	Third Coast Insurance Company	10713
	INSURER B:	United Financial Casualty Company	11770
	INSURER C:		
	INSURER D:	Clear Spring Property & Casualty	15563
	INSURER E:		

COVERAGES
 THE POLICIES OF INSURANCE LISTED BELOW HAVE BEEN ISSUED TO THE INSURED NAMED ABOVE FOR THE POLICY PERIOD INDICATED. NOTWITHSTANDING ANY REQUIREMENT, TERM OR CONDITION OF ANY CONTRACT OR OTHER DOCUMENT WITH RESPECT TO WHICH THIS CERTIFICATE MAY BE ISSUED OR MAY PERTAIN, THE INSURANCE AFFORDED BY THE POLICIES DESCRIBED HEREIN IS SUBJECT TO ALL THE TERMS, EXCLUSIONS AND CONDITIONS OF SUCH POLICIES. AGGREGATE LIMITS SHOWN MAY HAVE BEEN REDUCED BY PAID CLAIMS.

INSR LTR	ADD'L INSRD	TYPE OF INSURANCE	POLICY NUMBER	POLICY EFFECTIVE DATE (MM/DD/YY)	POLICY EXPIRATION DATE (MM/DD/YY)	LIMITS	
A	<input checked="" type="checkbox"/>	GENERAL LIABILITY <input checked="" type="checkbox"/> COMMERCIAL GENERAL LIABILITY <input type="checkbox"/> CLAIMS MADE <input checked="" type="checkbox"/> OCCUR <input type="checkbox"/> _____ <input type="checkbox"/> _____ GEN'L AGGREGATE LIMIT APPLIES PER: <input checked="" type="checkbox"/> POLICY <input type="checkbox"/> PROJECT <input type="checkbox"/> LOC	GLSISTC005713624	03/01/2024	03/01/2025	EACH OCCURENCE	\$1,000,000
						DAMAGE TO RENTED PREMISES (Ea occurrence)	\$50,000
						MED EXP (Any one person)	\$5,000
						PERSONAL & ADV INJURY	\$1,000,000
						GENERAL AGGREGATE	\$2,000,000
						PRODUCTS - COMP/OP AGG	\$2,000,000
							\$
B	<input type="checkbox"/>	AUTOMOBILE LIABILITY <input type="checkbox"/> ANY AUTO <input type="checkbox"/> ALL OWNED AUTOS <input checked="" type="checkbox"/> SCHEDULED AUTOS <input type="checkbox"/> HIRED AUTOS <input type="checkbox"/> NON-OWNED AUTOS <input type="checkbox"/> _____ <input type="checkbox"/> _____	971496840	07/13/2023	07/13/2024	COMBINED SINGLE LIMIT (Each Occurrence)	\$1,000,000
						BODILY INJURY (Per person)	\$
						BODILY INJURY (Per accident)	\$
						PROPERTY DAMAGE (Per accident)	\$
	<input type="checkbox"/>	GARAGE LIABILITY <input type="checkbox"/> ANY AUTO <input type="checkbox"/> _____				AUTO ONLY - EA ACCIDENT	\$
						OTHER THAN AUTO ONLY: EA ACC	\$
						AGG	\$
	<input type="checkbox"/>	EXCESS/UMBRELLA LIABILITY <input type="checkbox"/> OCCUR <input type="checkbox"/> CLAIMS MADE <input type="checkbox"/> DEDUCTIBLE <input type="checkbox"/> RETENTION \$_____				EACH OCCURRENCE	\$
						AGGREGATE	\$
							\$
							\$
							\$
D	<input type="checkbox"/>	WORKERS COMPENSATION AND EMPLOYERS' LIABILITY ANY PROPRIETOR/PARTNER/EXECUTIVE OFFICER/MEMBER EXCLUDED? If yes, describe under SPECIAL PROVISIONS below	CWC02035300	05/22/2023	05/22/2024	<input checked="" type="checkbox"/> WC STATUTORY LIMITS <input type="checkbox"/> OTHER	
						E.L. EACH ACCIDENT	\$1,000,000
						E.L. DISEASE - EA EMPLOYEE	\$1,000,000
						E.L. DISEASE - POLICY LIMIT	\$1,000,000
	<input type="checkbox"/>	OTHER					

DESCRIPTION OF OPERATIONS / LOCATIONS / VEHICLES / EXCLUSIONS ADDED BY ENDORSEMENT / SPECIAL PROVISIONS
 Certificate Holder is listed as an Additional Insured.
 The City of San Luis it's officers and employees are added as additional insureds.

CERTIFICATE HOLDER

CANCELLATION

City of San Luis

EXPIRATION DATE THEREOF, THE INSURER AFFORDING COVERAGE WILL ENDEAVOR TO MAIL 30 DAYS WRITTEN NOTICE TO THE CERTIFICATE HOLDER NAMED TO THE LEFT, BUT FAILURE TO DO SO SHALL IMPOSE NO OBLIGATION OR LIABILITY OF ANY KIND UPON THE INSURER, ITS AGENTS OR REPRESENTATIVES.

AUTHORIZED REPRESENTATIVE



Rene Rebollo

ACORD 25 (2001/08)

© ACORD CORPORATION 1988

IMPORTANT

If the certificate holder is an ADDITIONAL INSURED, the policy(ies) must be endorsed. A statement on this certificate does not confer rights to the certificate holder in lieu of such endorsement(s).

If SUBROGATION IS WAIVED, subject to the terms and conditions of the policy, certain policies may require an endorsement. A statement on this certificate does not confer rights to the certificate holder in lieu of such endorsement(s).

DISCLAIMER

The Certificate of Insurance on the reverse side of this form does not constitute a contract between the issuing insurer(s), authorized representative or producer, and the certificate holder, nor does it affirmatively or negatively amend, extend or alter the coverage afforded by the policies listed thereon.

STATE OF ARIZONA

Office of the
Registrar of Contractors

License No. ROC248137

This is to Certify That

D W D CONSTRUCTION (INDIV.)

having been shown to possess all the necessary qualifications, and having complied with all the requirements of the law,
is by order of the Registrar of Contractors duly licensed and admitted to engage in and pursue the business of

KB-01

DUAL BUILDING CONTRACTOR

Contractor in the State of Arizona. Given under my hand and the seal of the Registrar of Contractors

in my office, City of Phoenix, this 3RD day of SEPTEMBER, 2008.

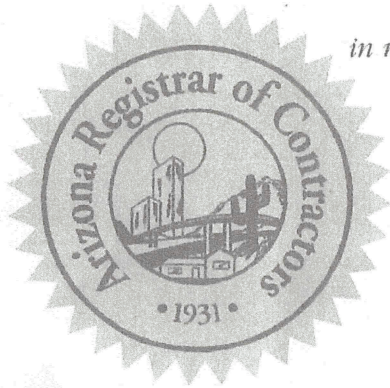

Fidelis V. Garcia

DIRECTOR

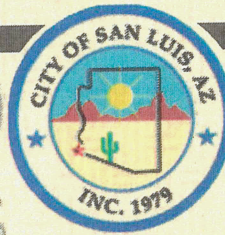

NO: 30731

City of San Luis 2024 Business License

13461 S. AVE. B YUMA, AZ 85365

IN CONSIDERATION OF: \$100.00 Dollars, Receipt of which is hereby acknowledged
The firm listed below is licensed to engage in and carry on business in the City of San Luis at the address indicated.

PERIOD ENDING: 12/31/2024

DWD CONSTRUCTION
NATHANIEL DAVID DARNELL
13461 S. AVE. B
YUMA, AZ 85365

Edgar Espinoza

THIS LICENSE MUST BE DISPLAYED IN A CONSPICUOUS PLACE SO AS TO BE EASILY VISIBLE TO THE PUBLIC AT ALL TIMES

**Request for Taxpayer
 Identification Number and Certification**

Give form to the requester. Do not send to the IRS.

Name (as shown on your income tax return) **D.W.D. Construction**

Business name, if different from above

Check appropriate box: Individual/Sole proprietor Corporation Partnership
 Limited liability company. Enter the tax classification (D: disregarded entity, C: corporation, P: partnership): Exempt payee
 Other (see instructions)

Address number, street, and apt. or suite no.: **13461 S. AVE B**

City, state, and ZIP code: **Yuma, AZ 85365**

List account number(s) here (optional)

Requester's name and address (optional)

Part I Taxpayer Identification Number (TIN)

Enter your TIN in the appropriate box. If the provided TIN matches the name given or, to avoid backup withholding, for individuals, this is your social security number (SSN). However, for a resident alien, proprietor, or disregarded entity, see the "Part I" instructions on page 3. If you do not have a TIN, see "Get a TIN" on page 3. Note: if the account is in your name, see the chart on page 10 for guidelines on whose number to enter.

Social security number

Employer identification number **86 0753622** mbr

Part II Certification

Under penalties of perjury, I certify that:

- The number shown on this form is my correct taxpayer identification number (or am waiting for a number to be issued to me and am not subject to backup withholding because: (a) I am exempt from backup withholding or have not been notified by the Internal Revenue Service (IRS) that I am subject to backup withholding as a result of a failure to report all interest or dividends, or (c) the IRS has notified me that I am no longer subject to backup withholding, and
- I am not subject to backup withholding because: (a) I am exempt from backup withholding or have not been notified by the Internal Revenue Service (IRS) that I am subject to backup withholding as a result of a failure to report all interest or dividends, or (c) the IRS has notified me that I am no longer subject to backup withholding, and
- I am a U.S. citizen or other U.S. person (defined below).

Certification instructions: You must check out item 2 above if you have been notified by the IRS that you are currently subject to backup withholding because you have failed to report all interest and dividends on your tax return. If you have real estate transactions, 2 does not apply to your mortgage interest paid acquisition or abandonment of secured property, cancellation debt, contributions to an individual retirement arrangement and generally, payments other than interest and dividends, you are not required to sign the Certification, but you must

provide your correct TIN. See the instructions on page 10.

Sign Here: Signature of **[Signature]** U.S. person Date **3/5/2024**

General Instructions

Section references are to the Internal Revenue Code unless otherwise noted.

Purpose of Form

A person who is required to file an information return with the IRS must file this form with the return if the payee is a U.S. person (other than a foreign estate), or a nonresident alien individual, or a foreign estate, or a partnership, corporation, or other entity organized in the United States or under the laws of the United States.

CITY OF SAN LUIS



REQUEST FOR BIDS (R.F.B.)

FINANCE WING RECONFIGURATION PROJECT AT SAN LUIS CITY HALL 1090 UNION ST, SAN LUIS, AZ 85349

MAILING ADDRESS:
P.O. Box 1170
SAN LUIS, AZ 85349

APPROVED BY:

ACTING CITY MANAGER:
JENNY TORRES

MAYOR:
NIEVES RIEDEL

VICE MAYOR:
GLORIA TORRES

COUNCIL MEMBERS:
MARIA CECILIA CRUZ
TADEO AZAEL DE LA HOYA
MATIAS ROSALES
LUIS E. CABRERA
JAVIER VARGAS

FEBRUARY 4, 2024

TABLE OF CONTENTS

1.	SUMMARY AND BACKGROUND	2
2.	BID GUIDELINES	2
3.	PROJECT DESCRIPTION	7
4.	REQUEST FOR BIDS PROJECT TIMELINE	9
5.	TERMS AND CONDITIONS	9
6.	MAP LAYOUT.....	11
7.	PROJECT IMAGES.....	11-15
8.	SEQUENCE OF CONSTRUCTION.....	16
9.	BID SCHEDULE.....	17
10.	BIDS SUBMITTAL FORM.....	18
11.	ADVERTISEMENT	19
12.	BID SURETY BOND FORM.....	20
13.	NON-COLLUSION AFFIDAVIT.....	21
14.	BIDDERS PARTICIPATION/SUBCONTRACTORS/SUPPLIERS LIST FORM.....	22
15.	SAMPLE CONTRACT/AGREEMENT	23-30

1. SUMMARY AND BACKGROUND

Sealed bids will be received by the City of San Luis (“City”), 1090 E. Union Street, P.O. Box 1170, San Luis, Arizona 85336, at the Office of City Clerk until 11:00 A.M., Arizona Time, Tuesday March 5th, 2024, and at that time publicly opened and read aloud, on the following:

Construction of a Municipal Complex Remodel and Reconfiguration of a portion of the Finance Wing of the administration building located at 1090 E. Union Street, San Luis, Arizona (“Project”).

General contract proposals will be received for the following scope of work: general construction; plumbing; heating, ventilating, and air conditioning; and electrical, as shown on the plans and specifications as prepared by Edais Engineering, Inc.

Sealed bids will be received by City of San Luis Clerk by hand or by mail:

City of San Luis Clerk
1090 Union St., PO Box 1170
San Luis, AZ 85336

Site visits and construction services will be coordinated through Facilities Project Coordinator.

Edgar Juarez
Facilities Project Coordinator
720 N 2nd Ave, P.O. Box 1170
San Luis, AZ 85336
(928) 341-8590, Ext. 1414
ejuarez@sanluisaz.gov

2. BID SUBMITTAL GUIDELINES

2.1 This Request for Bids represents the requirements for an open and competitive process. Bids will be accepted until **Tuesday March 5th, 2024**, 11a.m., Arizona Time. All bids must be signed by an official agent or representative of the company submitting the bid (“Bidder”).

2.2 Bids must be turned in a sealed envelope, directed to City of San Luis Clerk, with **“Bid for Finance Wing Reconfiguration Project at San Luis City Hall”**.

2.3 The City has divided the Project into three Sections. The Proposal submitted by Bidder shall make a proposal for each Section. The City reserves the right to award a Contract for each section separately and may award a contract for one, two, or all Sections in its discretion. The City reserves the right to award different Sections to different Bidders.

2.4 Non-disclosure of the data within a proposal cannot be guaranteed because of Public Records Laws.

- 2.5 No proposal may be withdrawn without the consent of the City for a period of ninety (90) days after the time for opening bids has passed.
- 2.6 The right is reserved to reject all bids or to waive any informalities in any bids and to accept any considered advantage to the City of San Luis.
- 2.7 If the bidder submitting a bid outsources or contracts any work to meet the requirements contained herein, this must be clearly stated in the bid. Any bid which calls for outsourcing or subcontracting work must include the name and description of the organizations being contracted. The amount of compensation being paid for said outsourced or subcontracted work must also be included.
- 2.8 The bidder shall include in the contract the sum of all applicable taxes, permit fees, and other costs to the bidder.
- 2.9 No bid shall be considered which is deemed as an irregular bid or which fails to conform in all material respects to the Plans, Specifications, and contract Documents. Bids may be deemed irregular and may be considered non-responsive for any of the following reasons:
 - A. If the bid is incomplete.
 - B. If the bidder does not supply or has improper or inadequate state contractor's license(s) to perform the work.
 - C. If there are unauthorized additions, statements, interlineations, alterations, conditional or alternate bids, or irregularities of any kind.
 - D. If the bidder adds any provisions reserving the right to accept or reject an award or to enter into a contract pursuant to an award.
 - E. If the bidder fails to submit any required document, including but not limited to any document attached as an exhibit hereto, or submit any information as required herein.
- 2.10 Bidders shall familiarize themselves with the provisions of the laws, codes, and regulations of the State of Arizona, City of San Luis, Yuma County, local agencies, and any entity or authority that has jurisdiction at the location of the site of this project. Contractors shall comply with, and require all subcontractors to comply with, all state and local contractor's license laws, including but not limited to City business license laws.
- 2.11 The following information shall be completed and submitted with the bid:
 - A. Addenda Form (if applicable)
 - B. AZ Bid Bond
 - C. Bid Proposal
 - D. No Collusion Affidavit
 - E. Subcontractor and Material Providers (Questionnaire)
- 2.12 Any bidder may withdraw or revise their bid by written request to the City at any time prior to the deadline for bid submittal as set forth in this Request for Bids. Any withdrawal or revision must be signed by a duly authorized representative of the bidder. If a bidder withdraws a bid after the time set for opening bids, the Bid Bond is subject to forfeiture as liquidated damages.
- 2.13 Any Addenda issued during the time of bidding shall become part of the documents used by the bidder for the preparation of his bid, shall be covered by the bid, and shall be made a part of the contract Documents. It is the sole responsibility of the bidder to ensure that they have received and reviewed all Addenda and submit the signed

and dated Addendum Acknowledgment Form.

- 2.14 The contract will be awarded to the lowest responsive and responsible bidder determined from the Bid Proposal, which complies with these instructions and with the Request for Bids. The City reserves the right to award a Contract for each section separately and may award a contract for one, two, or all sections in its discretion and may award different Sections to different Bidders and may enter into separate contracts for each Section. The City reserves the right to accept or reject any or all bids, to waive any informality or irregularity in the bids received, or to withhold the award for any reason the City, in its sole discretion, determines. Bids will be received until the time and date designated in the Request for Bids. The City will reject bids submitted after the designated deadline.
- 2.15 The City will not accept bids or award contracts to any person in arrears to the City for any debt or contract, in default on any surety bond, or otherwise deficient in any obligation to the City.
- 2.16 The City will notify the successful bidder that their bid has been accepted via a written Notice of Award to the address listed in the Bid Proposal. The form of contract that the successful bidder as the contractor will be required to execute is included in the contract Documents. The contract, bonds, insurance certificate, and other required forms shall be provided to the Facilities Project Coordinator of the City within ten (10) days after receipt of the Notice of Award, or the Bid Security shall be forfeited as provided elsewhere herein.
- 2.17 No binding contract will be formed until and unless all contract Documents have been fully executed.
- 2.18 The successful bidder, simultaneously with the execution of the contract, will be required to furnish the following documents:

A. Bonds: A Performance Bond in an amount equal to one hundred percent (100%) of the contract sum and a Materials and Labor (Payment) Bond equal to one hundred percent (100%) of the contract sum. Bonding companies and insurance carriers shall be “Best Rated B++ or better by A, M. Best Company or comparable rating as determined at the sole discretion of City. Each bond shall be executed by a surety (bonding company) duly licensed in and possessing a certificate of authority to transact surety business in the State of Arizona issued by the Arizona Department of Insurance and acceptable to the City. The Surety Bond shall not be executed by an individual surety or sureties. The bonds shall be written or countersigned by an authorized representative of the surety who is either a resident of the State of Arizona or whose principal office is maintained in the State of Arizona. The Bonds shall have attached thereto a certified copy of Power of Attorney for the signed official executing the bonds.

B. Insurance: bidder and/or subcontractors shall procure and maintain until all of their obligations have been discharged, including any warranty periods under this contract are satisfied, insurance against claims for injury to persons or damage to property which may arise from or in connection with the performance of the work hereunder by the bidder, his agents, representatives, employees, or subcontractors.

The insurance requirements herein are minimum requirements for the contract and in no way limit the indemnity covenants contained in the contract.

The City in no way warrants that the minimum limits contained herein are sufficient to protect the bidder from liabilities that might arise out of the performance of the work under this contract by the bidder, his agents, representatives, employees, or subcontractors.

Bidder is free to purchase such additional insurance as may be determined necessary.

Additional Insurance Requirements: The policies shall include, or be endorsed to include the following provisions:

1. On insurance policies where the City of San Luis is named as an additional insured, the The City of San Luis shall be an additional insured to the full limits of liability purchased by the bidder, even if those limits of liability are in excess of those required by this contract.

Additional Insured:

City of San Luis

1090 E Union Street

San Luis, AZ 85349

2. The vendor's insurance coverage shall be primary insurance and non-contributory with respect to all other available sources.

All certificates required by this contract shall be emailed directly to msabori@sanluisaz.gov and ejuarez@sanluisaz.gov. The City contract number and project description shall be noted on the certificate of insurance. The City reserves the right to require complete, certified copies of all insurance policies required by this contract at any time. Any Renewal of insurance certificates with endorsements will need to be emailed to the above emails at least two weeks prior to expiration.

Notice of Cancellation: With the exception of a ten (10) day notice of cancellation for nonpayment of premium, any changes to material to compliance with this contract in the insurance policies above shall require thirty (30) days written notice.

Acceptability of Insurers: Insurance is to be placed with insurers with a current A.M. Best's rating of no less than A-VII unless otherwise approved by the City of San Luis Risk Management Division.

Verification of Coverage: The vendor shall furnish the City with certificates of insurance (ACORD form or equivalent approved by the City) as required by this contract. The certificates for each insurance policy are to be signed by a person authorized by that insurer to bind coverage on its behalf.

All certificates and any required endorsements are to be received and approved by the City before work commences. Each insurance policy required by this contract must be in effect at or prior to the commencement of work under this contract and remain in effect for the

duration of the contract. Failure to maintain the insurance policies as required by this contract or to provide evidence of renewal is a material breach of contract.

Insurance Limit Requirements – The vendor shall provide coverage with limits of liability not less than those stated below. An excess liability policy or umbrella liability policy may be used to meet the minimum liability requirements provided that the coverage is written on a following form basis.

Commercial General Liability – Occurrence Form:

The policy shall include bodily injury, property damage, personal injury, and broad form. Contractual liability coverage.

- General Aggregate \$ 2,000,000
- Products – Completed Operations Aggregate \$ 1,000,000 (if applicable)
- Personal and Advertising Injury \$ 1,000,000 (if applicable)
- Each Occurrence \$ 1,000,000
- Fire Legal Liability (Damage to Rented Premises) \$ 100,000 (if applicable)

The policy shall be endorsed to include the following additional insured language: “The City of San Luis shall be named as an additional insured with respect to liability arising out of the activities performed by, or on behalf of, the vendor. “

Business Automobile Liability: Bodily Injury and Property Damage for any owned, hired, and/or non-owned vehicles used in the performance of this contract.

- Combined Single Limit (CSL) \$ 1,000,000

The policy shall be endorsed to include the following additional insured language: “The City of San Luis shall be named as an additional insured with respect to liability arising out of the activities performed by, or on behalf of the vendor.

Worker’s Compensation and Employer’s Liability:

Workers’ Compensation Statutory Employer’s Liability

- Each Accident - \$ 1,000,000
- Disease – each employee - \$ 1,000,000
- Disease – policy limit - \$ 1,000,000

The policy shall contain a waiver of subrogation against the City of San Luis for losses arising from work performed by or on behalf of the vendor.

All insurance required pursuant to this Agreement must be written by an insurance company authorized to do business in the State of Arizona, to be evidenced by a Certificate of Authority as defined in ARS Section 20-217, a copy of which certificate is to be attached to each applicable bond or binder.

Prior to commencing work under this Agreement, the vendor shall provide City with evidence that it is either a “self-insured employer” or a “carrier-insured employer” for Workers’ Compensation as required by ARS 23-901 et seq. or that it employs no persons subject to the requirement for such coverage.

C. Other: A current, fully complete W-9.

2.19 No Assignment by a bidder or contractor of any contract to be entered into hereunder, or any part thereof, or of funds to be received thereunder by the contractor, will be

recognized by the City unless such assignment has had prior written approval of the City; and the surety has been given due notice of such assignment in writing and has consented thereto in writing.

2.20 The contractor shall achieve the final completion of work on or before June 27, 2024.

2.21 Each bidder shall deposit with his or her proposal a certified check or bank draft by a responsible bank, payable to the order of the City, or a satisfactory bid bond executed by the bidder with a surety acceptable to the City in an amount equal to ten percent (10%) of the bid. The bid bond or certified check shall be forfeited in case the contractor fails to enter into a contract with good and sufficient bond within fourteen (14) days after notification by the City.

2.22 The successful bidder will be required to furnish satisfactory performance bond and labor and material payment bond in a sum equal to the contract price, in form and with surety satisfactory to the City.

2.23 The successful bidder shall obtain and provide all necessary permits as part of the proposal.

3. PROJECT DESCRIPTION

3.1 The City of San Luis is seeking cost proposals to remodel the finance wing at City Hall. The following are the estimated tasks associated with this project. A Project Map is attached as an exhibit hereto and, by this reference is incorporated herein.

3.2 Description of work: The remodeling of the finance wing will be broken down into three sections. Section 1 will be an addition of three enclosed offices, section 2 will be an expansion of a conference room, and section 3 will be an addition of one restroom and storage room. Each of these sections involves demolition/removal of existing walls, new openings in walls for doors, the addition of walls to matching texture and color, the addition of matching doors, addition of matching windows, electrical work, replacement of lighting fixtures, replacement/relocation of HVAC, and other improvements as in the engineering plans. Divisions within the construction location will take care of removing personal decorations and paperwork. The City's I.T. division will remove computers and electronics prior to moving furniture and install them after work is performed. The contractor is responsible for removing furniture to an allocated area by City staff and replacing it after a section is completed. The proposal for each section must be quoted individually. Before initiating a section, the contractor must close/barricade the section without limiting emergency exits to minimize closing facility and essential functions. Improvements to these sections must follow the engineering plans provided.

Section 1 – Addition of three enclosed offices.

- Removal of furniture, cubicles, and obstructions.
- Demolition of wall into old H.R. section.
- Addition of walls for three new offices. Drywall, texture, and color to match existing.
- Removal of wall sections to add door and window to existing office of old H.R. director.
- Sealing of old H.R. director's door.
- Addition of (4) doors, (4) windows, and hardware to match existing.

- Addition of electrical and data ports.
- Acoustical ceiling relocated and/or replaced.
- HVAC supply relocated and/or replaced.
- Fire pull box relocated and/or replaced.
- Ceiling lighting relocated and/or replaced to match existing.
- Addition of light switches and working independently in each office.
- Moving/Returning furniture to its original space.

Section 2 – Expansion of conference Room

- Removal of furniture and obstructions.
- Demolition of wall
- Addition of wall with drywall, texture, and color to match existing walls.
- Acoustical ceiling relocated and/or replaced.
- HVAC supply relocated and/or replaced.
- Ceiling lighting relocated and/or replaced to match existing.
- Addition of strobe for fire emergency.
- Moving/Returning furniture to its original space.

Section 3 – Addition of restroom/storage

- Removal of furniture and obstructions.
- Removal of existing carpet and baseboards for new restroom flooring. Save carpet for other sections if needed.
- Plumbing for new restroom
- Preparation of surfaces.
- Installation of new restroom flooring (floor tile) to match other restrooms.
- Removal of walls and window to add doors to match existing. Door 1 into restroom access and door 2 into storage area.
- Addition of electrical ports and light switch.
- Acoustical ceiling relocated and/or replaced.
- HVAC supply relocated and/or replaced.
- Addition of strobe for fire emergency in restroom.
- Moving/Returning furniture to its original space.
- FRP Walls

General: Contractor shall:

3.3 Coordinate with Facilities Project Coordinator in sequence of events of all work to minimize impact to services. The owner will request for floor to be installed in sections to prevent closing of facility and essential functions.

3.4 Follow proposed schedule provided by the “City” with areas phased in so staff can clear spaces to complete work.

3.5 Be responsible for removal and disposal of existing materials, trash, and debris.

3.6 Be responsible for all fees associated with disposal.

- 3.7 Be responsible for preparation of surfaces for construction including leveling, scraping of substrate to remove debris, subfloor preparation, drywall patching and paint overspray, filling cracks and holes.
- 3.8 Be responsible for final cleanup of all surfaces once construction is complete.
- 3.9 Site Visit: Contractor must coordinate a site visit through Facilities Project Coordinator listed above for proposal to be considered responsive.

4. REQUEST FOR BIDS PROJECT TIMELINE (ALL IN ARIZONA TIME)

- **February 4th and February 11th, 2024, at 8 a.m.** – Advertisement dates, Start Project Timeline
- **February 21st, 2024, at 1:00 p.m.** - A Pre-bid meeting will be held at Pedro Julian Multipurpose Room at City Hall.
- **March 5th, 2024, at 11:00 a.m.** - All bids in response to this RFP are due.
- **March 5th, 2024, at 11:00 a.m.** – Bid Opening
- **March 5th – 7th, 2024** - Evaluation of bids will be conducted. If additional information or discussions are needed with any bidders during this window, the bidder(s) will be notified.
- **March 7th, 2024** – The staff recommendation to present to City Council for the lowest responsible bidder is expected to be made.
- **March 27th, 2024** – City Council selection of lowest bidder.
- **March 28th – April 2nd, 2024** – Contract negotiation with the winning bidder.
- **April 3rd, 2024 – June 27th, 2024** – Project completion time frame.

4.1 This project requires recommendation by the City of San Luis Facilities Department and approval for award by the City of San Luis Council. It is anticipated that this work would be recommended and approved at a **March 27th, 2024**, Council meeting.

4.2. Construction work on this project is allowed Monday to Thursday, 6 p.m. – 6 a.m., Friday to Sunday all day, excluding holidays. Additional hours may be granted by Facilities Project Coordinator, if the project phase does not consist of loud noises, dust, debris, and distractions to city staff.

4.3 Completion is to occur no later than **June 27th, 2024**.

4.4 Questions for the city will be gathered into one email communication from the prospective bidders and submitted to Edgar Juarez, Facility Project Coordinator at ejarez@sanluisaz.gov. All inquiries must be received by **February 23rd, 2024**. All inquiries made by prospective bidders will be answered by the City by **February 27th, 2024** and will be submitted to all interested parties to ensure that all parties are operating with the same information.

5. Terms and Conditions

7.1 If for any reason, the firm selected shall fail to fulfill the obligations agreed to in a timely manner, the City shall have the right to terminate the contract by specifying the date of termination in a written notice to the firm at least (7) days before the termination date. In this event, the firm shall be entitled to just and equitable compensation for the work satisfactorily completed.

7.2 “Provider agrees to indemnify, defend and hold harmless the City and its officers, officials, employees and agents from and against any and all liability, loss, damage expense, costs, (including attorney fees) arising out of this agreement, caused in whole or in part by the Provider or anyone for whose acts any of them may be liable, except where caused by the sole negligence or willful misconduct of the City.”

- 7.3 The contract resulting from the award of this RFB shall commence upon execution after award by the City Council.
- 7.4 All costs associated with preparation, submittal and presentation of bids shall be borne by the bidder.
- 7.5 Work shall be completed by technicians who are qualified in their area of work.
- 7.6 Contractors shall provide submittals for all materials prior to start of construction. The owner shall approve materials prior to installation.
- 7.7 If in the course of work, the contractor damages, marks, or misplaces anything they will replace it or restore it to its original condition. Based on the contractor's proposed fixes, the owner shall decide the best course of action to repair any damage done by the contractor.
- 7.8 The City of San Luis will notify the successful respondent by telephone, followed by written confirmation. Each respondent whose bid is not accepted will receive notification by mail. The City of San Luis will authorize the award of a contract to the successful respondent. If a contract cannot be finalized within fifteen (15) days of the award, the City reserves the right to enter into negotiations with another respondent.
- 7.9 Respondents not selected have ten business days from email delivery notification to initiate a written protest. The City of San Luis reserves the right to reject any or all responses; to make modifications to, or waive irregularities of information in any RFB, if city staff deems this to be in the best interest of the City of San Luis. The City of San Luis may decide to readvertise the RFB and/or to take any steps determined prudent to resolve the protest.

Project Map

- * Electronic copy of plans may be requested to Facilities Project Coordinator at ejvarez@sanluisaz.gov.
- * The project sections are highlighted in yellow, blue, and red.

San Luis City Hall

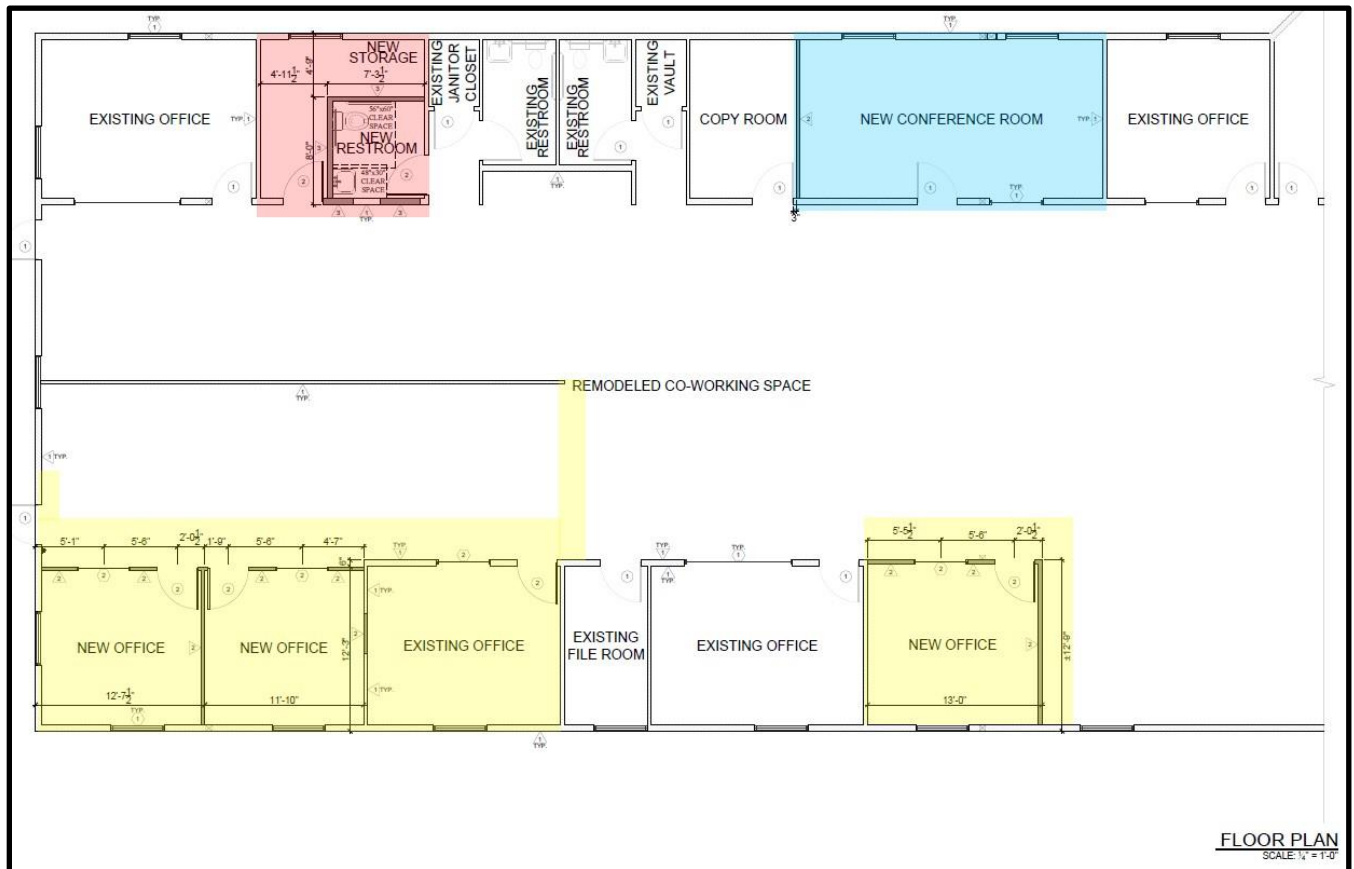

Section 1: Yellow
Section 2: Blue
Section 3: Red

Project Images



Section 1: Addition of 2 enclosed offices



Section 1: Addition of 1 enclosed office



Section 1: Removal of wall into old HR division.



Section 2: Expansion of office to new conference room.



Section 2: Extension of Conference Room, Image of copy room that will decrease in size.



Section 3: Installation of new restroom. On the left: Office will turn into restroom and storage.



Section 3: Office into new restroom and storage.

CITY HALL FINANCE WING IMPROVEMENTS

Sequence of Construction

Preparation Phase:

Obtain necessary permits and approvals from local authorities.
Notify employees about upcoming construction activities.
Secure the site with appropriate dust and debris control barriers and signage.
Disconnect electrical system on the area.

Demolition Plan:

Survey the building to identify areas for demolition and modifications in the designated areas.
Develop a detailed demolition plan outlining which walls, fixtures, and other elements need to be removed based on the approved plans.
Arrange for the removal of hazardous materials by certified professionals. (If Any)
Implement safety measures to protect office employees and minimize disruption to surrounding areas.

Demolition Execution:

Begin demolition work according to the approved plan, including removal of walls and existing light fixtures in designated areas.
Remove T-grid ceiling sections adjacent to the new office wall before construction begins.

Construction Execution:

Begin construction of new office spaces according to the approved plans.
Begin framing construction of the new walls as per the design.
Coordinate with subcontractors for electrical work, including relocation of receptacle outlets and installation/replacement of light fixtures.
Apply drywall texture and paint to match existing wall finishes, maintaining consistency throughout the building.
Ensure compliance with building codes and safety regulations throughout the construction process.
Implement quality control measures to maintain construction standards.
Minimize construction waste in the building during construction.

Interior Finishing:

Install interior finishes such as flooring, paint, doors, and trim according to the design specifications, to match existing finishes.
Adjust T-grid ceiling to match the rest of the building ceilings, ensuring uniformity.
Coordinate installation of electrical outlets, light fixtures, AC return ducts, data ports, and other fixtures in the new offices.
Conduct final inspections to ensure that the new offices meet quality standards and comply with regulations.

Testing and Commissioning:

Test all electrical systems, HVAC systems, and fixtures to ensure functionality and safety.
Conduct thorough inspections of the new offices and common areas to identify any defects or issues.
Address any deficiencies promptly to ensure the project meets the required standards.

Final Touches:

Complete any remaining finishing touches, such as cleaning the premises and removing construction debris.

City of San Luis
Finance Wing Reconfiguration Project
BID PROPOSAL
Bid Submittal Form

Bid Schedule

Section 1: Addition of 3 Enclosed Offices					
Bid Item	Item Description	Estimated Quantities	Unit	Unit Price	Total
1	Labor: Demolition of existing walls, preparation of surfaces, and installation of new improvements.	1	Lump Sum		
2	All materials and equipment	1	Lump Sum		
3	Taxes and Fees	1	Lump Sum		
				Subtotal	
				5% Contingency	
				Total	

Section 2: Expansion of Conference Room					
Bid Item	Item Description	Estimated Quantities	Unit	Unit Price	Total
1	Labor: Demolition of existing walls, preparation of surfaces, and installation of new improvements.	1	Lump Sum		
2	All materials and equipment	1	Lump Sum		
3	Taxes and Fees	1	Lump Sum		
				Subtotal	
				5% Contingency	
				Total	

Section 3: Addition of Restroom					
Bid Item	Item Description	Estimated Quantities	Unit	Unit Price	Total
1	Labor: Demolition of existing walls, preparation of surfaces, and installation of new improvements.	1	Lump Sum		
2	All materials and equipment	1	Lump Sum		
3	Taxes and Fees	1	Lump Sum		
				Subtotal	
				5% Contingency	
				Total	

GRAND

TOTAL _____ (Bidder understands that City reserves the right to award a Contract for each section separately and may award a contract for one, two, or all sections in its discretion and may award different Sections to different Bidders.)

THIS PROPOSAL IS SUBMITTED BY _____,

A corporation organized under the laws of the State of _____,

or a partnership consisting of _____,

or individual trading as _____,

of the City of _____ (City, State) and is the holder of Arizona State Contractor's license(s): _____ (type) Classification _____ License No. _____.

The bidder hereby certifies that as of the below date, the bond amount posted with the Arizona Registrar of Contractors is \$ _____ and the Bidder's actual volume of work has not exceeded the contemplated gross volume pursuant to Arizona Administrative Code, Title 4 Chapter 9 [Authority: ARS 32-1101 et seq.]

Respectfully submitted,

Bidders Firm _____

Address _____

City, State, ZIP _____

By _____
[Signature] [Date]

Name _____

Title _____

ATTEST:
[If Bidder is an individual]

Witness: _____
[Signature] [Date]



Request for Proposals City of San Luis, Arizona

Finance Wing Reconfiguration Project at San Luis City Hall

NOTICE IS HEREBY GIVEN THAT sealed proposals or bids will be received in the Office of City Clerk, City Hall, 1090 E Union Street, City of San Luis, Arizona **until 11:00 A.M. (Arizona Time) on Tuesday February 27th, 2024**, for furnishing all labor, materials, equipment, tools and performing all services required for the **Finance Wing Reconfiguration Project at San Luis City Hall**. Proposals will then be publicly opened and read aloud. Each bid should be submitted in the proposal form and be accompanied by a certified check or bid bond in the amount of ten percent of the total amount of the bid.

The proposed work is located at the San Luis City Hall, 1090 Union St., in San Luis, Arizona, 85349. The work consists of remodeling Finance Wing in three different sections: Section 1 consists of addition of 3 new offices, section 2 consists of conference room expansion, and section 3 consists of addition of a restroom. Work will be performed per specifications in the Request for Proposal package and Project Plans.

The project shall be completed from the dates March 18th, 2024, and finished no later than June 20th, 2024. Site visits, RFP documents, and further information can be obtained at the office of:

Edgar Juarez, Facilities Project Coordinator, 720 N 2nd Avenue, San Luis, Arizona 85349, ej Suarez@sanluisaz.gov, 928-341-8590, Ext: 1414.

A non-mandatory pre-bid conference will be held at the City of San Luis Pedro Julian Conference Room in City Hall on **Tuesday, February 13th, 2024, at 1pm (Arizona Time)** to discuss specifications and any questions bidders may have.

All bids must be in a sealed envelope and plainly marked: **“Proposal for Finance Wing Reconfiguration Project at San Luis City Hall.”**

The City of San Luis reserves the right to cancel this procurement, and/or to reject any or all bids, and/or to waive any informality in any bid. No bidder may withdraw his bid for a period of sixty (60) days after the date set for the bid opening thereof:

City of San Luis, Arizona

JENNY TORRES, Acting City Manager
Yuma Sun: 2/4/24 & 2/11/24

BID SURETY BOND

Project Name:

For: City of San Luis, Arizona

KNOWN ALL MEN BY THESE PRESENTS:

That we, _____, as Principal, (hereinafter call the Principal), and the _____, a corporation duly organized under the laws of the State of _____

And duly licensed and possessing a certificate of authority to transact surety business in the State of Arizona, as Surety, (hereinafter called the Surety), are held and firmly bound unto City of San Luis, Arizona [hereinafter called City] as Obligee, in the sum of ten percent (10%) of the total amount of the bid of Principal, submitted by him to the City of the work described below, for the payment of which sum, well and truly to be made, the said Principal and the said surety bind ourselves, our heirs, executors, and administrators, successors, and assigns, jointly and severally, firmly by these presents, and in conformance with Arizona Revised Statutes [ARS].

WHEREAS, the said Principal is herewith submitting its PROPOSAL for:

Project Name: _____

NOW, THEREFORE, if the City shall accept the PROPOSAL of the Principal and the Principal shall enter into a CONTRACT with the City in accordance with the terms of the proposal and give the Bonds and Certificates of Insurance as specified in the Standard Specifications with good and sufficient Surety for the faithful performance of the CONTRACT and for the prompt payment of labor and materials furnished in the prosecution of the CONTRACT, or in the event of the failure of the Principal to enter into the CONTRACT and give the Bonds and Certificates of Insurance, if the Principal pays to the City the difference not to exceed the penalty of the bond between the amount specified in the PROPOSAL and such larger amount for this the Obligee may in good faith contract with another party to perform the work covered by the PROPOSAL then this is void. Otherwise, it remains in full force and effect provided, however, that this bond is executed pursuant to the provisions of Section 34-201, ARS, and all liabilities of this bond shall be determined in accordance with the provisions of the section to the extent as if it were copied at length herein.

Signed and sealed this _____ day of _____, 2024

Principal Firm [Seal]

Surety Firm [Seal]

Principal Signature

Surety Signature

Name and Title

Name and Title

Agency of Record

Address

NOTE: Attach current power of attorney}

NON-COLLUSION AFFIDAVIT

Project Name:

To: City of San Luis, Arizona

That pursuant to Section 1128 of Title 23 USC, the undersigned in submitting a PROPOSAL for performing the following work by CONTRACT, being duly sworn, disposes and says that he has not, nor anyone associated with the business identified below, either directly or indirectly, entered into any agreement, participated in any collusion or otherwise taken any action in restraint of free competitive bidding in connection with this CONTRACT.

Signature of Bidder

Title

Business Name

Address

Subscribed and sworn to before me this _____ day of _____, 20____.

Notary Public

Notary Public in and for the County of _____, State _____.

My Commission Expires _____, 20____.

**BIDDER'S PARTICIPATION,
SUBCONTRACTOR AND SUPPLIERS LIST**

Project Name:

For: City of San Luis, Arizona

This form shall be submitted along with the PROPOSAL in the same sealed envelope.

The BIDDER must list below the names and addresses of all qualified subcontractors and major suppliers to be employed on the various portions of the work indicated.

BIDDER AN ALL CONTRACTORS SHALL BE DULY LICENSED IN ACCORDANCE WITH ARIZONA REVISED STATUTES AT THE TIME OF THE BID OPENING

BIDDER,

**SUBCONTRACTOR
AND/OR SUPPLIER**

**CURRENT AZ LICENSE
[CONTRACTOR/SUB CONTRACTOR]**

1. _____

2. _____

3. _____

4. _____

5. _____

CONSTRUCTION CONTRACT

This Construction Contract (this “Contract”) made this ____ day of _____, 2024, between _____, having its principal office at _____ (“Contractor”), and the City of San Luis, Arizona, a municipal corporation, 1090 E. Union Street, San Luis, Arizona 85336 (“City”).

SECTION ONE.

CONTRACT DOCUMENTS

The advertisement for bids, the Request for Bids (“RFB”) for Construction of a Municipal Complex Remodel and Reconfiguration of a portion of the Finance Wing of the administration building located at 1090 E. Union Street, San Luis, Arizona (“Project”), the Plans and Specifications for Project, the Proposal, Addenda, Bonds required by the RFB, documents or submittals required by the RFB, Certificates of Insurance required by the RFB, Change Orders, if any, are, by this reference made a part of this Contract to the same extent as if fully set forth again in full. Part 101 of the 2015 Maricopa Association of Governments Uniform Standard Specifications for Public Works Construction as adopted by the City of San Luis as its Public Works Standards (“Part 101”), shall apply to this Contract. In the event of a conflict between Part 101 and the RFB, the terms and conditions of the RFB shall control. All references to Engineer in Part 101 shall refer to the Facilities Project Coordinator.

SECTION TWO.

DESCRIPTION OF WORK

Contractor will perform the work described in the Request For Bids for Construction of a Municipal Complex Remodel and Reconfiguration of a portion of the Finance Wing of the Administration Building located at 1090 E. Union Street, San Luis, Arizona (“Project”). City has divided the Project into three Sections.

This contract shall be for Section(s) _____ as set forth in the Proposal submitted by Contractor.

SECTION THREE.

THE CONTRACT PRICE

City shall pay Contractor the fixed sum of \$ _____ (the “Contract Price”) for the work to be performed under this Contract, subject to additions and deductions pursuant to change orders agreed upon in writing by the parties.

SECTION FOUR.

PAYMENT SCHEDULE

The Contract Price shall be paid upon completion of the work for each Section for the Section or Sections described above. Payment to be made within 30 days after billing.

**SECTION FIVE.
START AND COMPLETION OF WORK**

The work to be performed under this Contract shall be commenced on approximately _____, as long as any required building permits are received and any agreed upon funds are paid to Contractor. The Project shall be completed by approximately June 20, 2024, subject to permissible delays as defined in this Contract. Substantial commencement of the work shall be deemed to occur when Contractor first supplies workers to the Project who actually commence construction operations.

**SECTION SIX.
PERMITS AND TESTS**

Unless otherwise agreed in writing by the parties, City shall be responsible for the cost of all permits required for the Project. City shall also be responsible for the cost of any testing or inspection of the Project which may be required.

**SECTION SEVEN.
PERMISSIBLE DELAYS**

Contractor shall be excused from any delay in the completion of the work to be performed under this Contract caused by acts of nature, inclement weather, acts or omissions of City or of City's agents, employees or independent contractors, material shortages, strikes or other labor troubles, acts of public utilities, acts of public bodies or inspectors (unless related to defects in Contractor's performance), extra work, changes requested by City, failure by City to make payments promptly, or other circumstances or contingencies unforeseen by Contractor and beyond Contractor's reasonable control.

**SECTION EIGHT.
EXTRA WORK**

No extra work is to be performed without a written change order approved by City. Prior to approval of such change order, Contractor shall provide an estimate of cost for such extra work, and at no time shall the cost for such extra work exceed said estimate.

**SECTION NINE.
RELEASE OF MECHANICS' LIENS**

Upon satisfactory payment being made for any portion of the work performed, Contractor shall, prior to

any further payment being made, furnish to City a full and unconditional release from any claim or mechanic's lien pursuant to *[citation of statute]*, for that portion of the work for which payment has been made.

SECTION TEN.

INSURANCE

Bidder and/or subcontractors shall procure and maintain until all of their obligations have been discharged, including any warranty periods under this Contract are satisfied, insurance against claims for injury to persons or damage to property which may arise from or in connection with the performance of the work hereunder by the Bidder, his agents, representatives, employees, or subcontractors.

The insurance requirements herein are minimum requirements for the Contract and in no way limit the indemnity covenants contained in the Contract.

The City in no way warrants that the minimum limits contained herein are sufficient to protect the Bidder from liabilities that might arise out of the performance of the work under this Contract by the Bidder, his agents, representatives, employees, or subcontractors. Bidder is free to purchase such additional insurance as may be determined necessary.

Additional Insurance Requirements: The policies shall include, or be endorsed to include the following provisions:

1. On insurance policies where the City of San Luis is named as an additional insured, the City of San Luis shall be an additional insured to the full limits of liability purchased by the Bidder even if those limits of liability are in excess of those required by this Contract.

Additional Insured:

City of San Luis

1090 E Union Street

San Luis, AZ 85349

2. The Vendor's insurance coverage shall be primary insurance and non-contributory with respect to all other available sources.

All certificates required by this Contract shall be emailed directly to msabori@sanluisaz.gov and ejarez@sanluisaz.gov. The City contract number and project description shall be noted on the certificate of insurance. The City reserves the right to require complete, certified copies of all insurance policies required by this Contract at any time. Any Renewal of insurance certificates with endorsements will need to be emailed to the above emails at least two weeks prior to expiration.

Notice of Cancellation: With the exception of a ten (10) day notice of cancellation for nonpayment of premium, any changes to material to compliance with this contract in the insurance policies above shall require thirty (30) days written notice.

Acceptability of Insurers: Insurance is to be placed with insurers with a current A.M. Best's rating of no less than A-VII, unless otherwise approved by the City of San Luis Risk Management Division.

Verification of Coverage: Vendor shall furnish the City with certificates of insurance (ACORD form or equivalent approved by the City) as required by this Contract. The certificates for each insurance policy are to be signed by a person authorized by that insurer to bind coverage on its behalf.

All certificates and any required endorsements are to be received and approved by the City before work commences. Each insurance policy required by this Contract must be in effect at or prior to commencement of work under this Contract and remain in effect for the duration of the contract. Failure to maintain the insurance policies as required by this Contract or to provide evidence of renewal is a material breach of contract.

Insurance Limit Requirements - Vendor shall provide coverage with limits of liability not less than those stated below. An excess liability policy or umbrella liability policy may be used to meet the minimum liability requirements provided that the coverage is written on a following form basis.

Commercial General Liability – Occurrence Form:

Policy shall include bodily injury, property damage, personal injury, broad form.

contractual liability coverage.

- General Aggregate \$ 2,000,000
- Products – Completed Operations Aggregate \$ 1,000,000 (if applicable)
- Personal and Advertising Injury \$ 1,000,000 (if applicable)
- Each Occurrence \$ 1,000,000
- Fire Legal Liability (Damage to Rented Premises) \$ 100,000 (if applicable)

The policy shall be endorsed to include the following additional insured language: "The City of San Luis shall be named as an additional insured with respect to liability arising out of the activities performed by, or on behalf of, the Vendor".

Business Automobile Liability: Bodily Injury and Property Damage for any owned, hired, and/or non-owned vehicles used in the performance of this Contract.

- Combined Single Limit (CSL) \$ 1,000,000

The policy shall be endorsed to include the following additional insured language: "The City of San Luis shall be named as an additional insured with respect to liability arising out of the activities performed by, or on behalf of the Vendor".

Worker's Compensation and Employer's Liability:

Workers' Compensation Statutory Employer's Liability

- Each Accident - \$ 1,000,000
- Disease – each employee - \$ 1,000,000

· Disease – policy limit - \$ 1,000,000

Policy shall contain a waiver of subrogation against the City of San Luis for losses arising from work performed by or on behalf of the Vendor.

All insurance required pursuant to this Agreement must be written by an insurance company authorized to do business in the State of Arizona, to be evidenced by a Certificate of Authority as defined in ARS Section 20-217, a copy of which certificate is to be attached to each applicable bond or binder.

Prior to commencing work under this Agreement, the Vendor shall provide City with evidence that it is either a “self-insured employer” or a “carrier insured employer” for Workers’ Compensation as required by ARS 23-901 et seq., or that it employs no persons subject to the requirement for such coverage.

SECTION ELEVEN. MISCELLANEOUS

A. Waiver. No delay in exercising any right or remedy shall constitute a waiver thereof, and no waiver by the Contractor or City of the breach of any covenant of this agreement shall be construed as a waiver of any preceding or succeeding breach of the same or any other covenant or condition of this contract.

B. Attorneys’ Fees. In the event any party finds it necessary to bring any action at law or other proceeding, including arbitration, against the another party to enforce any of the terms, covenants or conditions hereof, or by reason of any breach or default hereunder, the party prevailing in any such action or other proceeding shall be paid all reasonable costs and reasonable attorneys’ fees by the other party, and in the event any judgment is secured by said prevailing party, all such costs and attorneys’ fees shall be included therein, such fees to be set by the court and not by jury.

C. Counterparts. This agreement may be executed in one or more counterparts, each of which shall be deemed an original, but all of which together shall constitute one and the same instrument. The signature pages from one or more counterparts may be removed from such counterparts and such signature pages all attached to a single instrument so that the signature of all parties may be physically attached to a single document.

D. Headings. The descriptive headings of the paragraphs of this agreement are inserted for convenience only and shall not control or affect the meaning or construction of any of the provisions hereof.

E. Further Acts. Each of the parties hereto shall execute and deliver all such documents and perform all such acts as reasonably necessary, from time to time, to carry out the matters contemplated by this contract.

F. Time of the Essence. Time is of the essence of this contract.

G. No Partnership and Third Parties. It is not intended by this agreement to, and nothing contained in this agreement shall, create any partnership, joint venture or other similar arrangement between Contractor or City. No term or provision of this agreement is intended to, or shall, be for the benefit of any person, firm, organization, or corporation not a party hereto, and no such other person, firm, organization, or corporation shall have any right or cause of action hereunder.

H. Entire Agreement. This agreement constitutes the entire agreement between the parties hereto pertaining to the subject matter hereof. All prior and contemporaneous agreements, representations, and understandings of the parties, oral or written, are hereby superseded and merged herein.

I. Amendment. No change or additions are to be made to this agreement except by a written amendment executed by the parties hereto.

J. Governing Law. This agreement is entered into in Arizona and shall be construed and interpreted under the laws of the State of Arizona. In particular, this agreement is subject to the provisions of A.R.S. § 38 511.

K. Reformation. Should any term, provision, covenant, or condition of this agreement be held to be void or invalid, the parties shall reform this agreement to conform as closely as possible to the original intent thereof.

L. Venue. Any legal action relating to this agreement shall be brought in either the Yuma County Superior Court or in the United States District Court for the District of Arizona at the election of the plaintiff in such legal action, provided, however, that nothing in this paragraph will be deemed to have authorized the bringing of any legal action in a court which does not otherwise have jurisdiction to adjudicate the legal action.

M. Severability. Every provision of this agreement is, and will be construed to be, a separate and independent covenant. If any provision of this agreement or the application of the same is, to any extent, found to be invalid or unenforceable, then the remainder of this agreement or the application of that provision to circumstances other than those to which it is invalid or unenforceable, will not be affected by that invalidity or unenforceability, and each provision of this agreement will be valid and will be enforced to the extent permitted by the law, and the parties will negotiate in good faith for such amendments of this agreement which may be necessary to achieve its intent, notwithstanding such invalidity or unenforceability.

N. No Personal Liability. No member, official or employee of the City shall be personally liable to CONTRACTOR, or any successor or assignee, (a) in the event of any default or breach by the City, (b) for any amount which may become due to CONTRACTOR or its successor or assign, or (c) pursuant to any obligation of the City under the terms of this contract.

O. Employment Eligibility. CONTRACTOR hereby warrants, and shall require its subcontractors to warrant, that it is in compliance with all federal immigration laws and regulations that relate to its employees and with A.R.S. §23-214 relating to verification of employment eligibility. A breach of this warranty shall be deemed a material breach of the agreement and is subject to penalties up to and including termination of this agreement. City retains the legal right to inspect the papers of CONTRACTOR and any contractor or subcontractor employee of CONTRACTOR to ensure that CONTRACTOR and any of its contractors or subcontractors are compliant with this warranty.

P. Sudan/Iran Investments and Business Operations. By entering into this agreement, Licensee certifies that it does not have scrutinized business operations in Iran or Sudan as those terms are defined in A.R.S. §35-391 et seq. and §35-393 et seq.

Q. No Forced Labor of the Ethnic Uyghurs. Under A.R.S. § 35-394 Contractor certifies, to the extent permitted by law, that it does not currently, and agrees for the duration of this Contract that it will not, use:

1. The forced labor of ethnic Uyghurs in the People's Republic of China.
2. Any goods or services produced by the forced labor of ethnic Uyghurs in the People's Republic of China.
3. Any contractors, subcontractors or suppliers that use the forced labor or any goods or services produced by the forced labor of ethnic Uyghurs in the People's Republic of China.

R. No Israel Boycott. Contractor hereby certifies that the Contractor is not currently engaged in and agrees for the duration of the contract to not engage in, a boycott of goods or services from Israel.

S. Compliance with Law. Contractor that it will comply with all federal, state, and local statutes, laws, ordinances, rules, and regulations. The Contractor will comply with the Americans with Disabilities Act (ADA) and will indemnify the City for any costs, including but not limited to, damages, attorney's fees, and staff time in any action or proceeding brought alleging violation of the ADA. The Contractor will not discriminate against any person on the basis of race, religion, color, age, sex, or national origin in the performance of this Contract, and must comply with the terms and intent of Title VII of the Civil Rights Act of 1964, P.L. 88-354 (1964). In addition, the Contractor must include similar requirements of subcontractors in any contracts entered into for performance of the Contractor's obligations under this Contract. The Contractor agrees not to participate in or cooperate with an international boycott, as defined in Section 999 (b)(3) and (4) of the Internal Revenue Code of 1954, as

amended, or engage in conduct declared to be unlawful by Arizona state law. In addition, the Contractor must include similar requirements of all subcontractors in contracts entered for performance of the CONTRACTOR's obligations under this Contract.

T. Assignment. The rights of each party under this agreement are personal to that party and may not be assigned or transferred to any other person, firm, corporation, or other entity without the prior, express, and written consent of the other party.

The parties have executed this Construction Contract at San Luis, Arizona the day and year first set forth above.

CONTRACTOR

By: _____

THE CITY OF SAN LUIS, an Arizona municipal corporation

By: _____

ATTEST:

By: _____

City Clerk

APPROVED AS TO FORM:

City Attorney



CITY OF SAN LUIS
FINANCE WING RECONFIGURATION PROJECT AT CITY HALL
Bid Addendum #1

This Addendum Changes/Updates the following:

Date Issued: **2/22/24**

To: **All prospective bidders**

Addition 1: Any surface where walls will be removed must be replaced with carpet to match existing carpet color and height. Replacement of the carpet area must be kept to a minimum. We are replacing the flooring soon; however, we want to prevent tripping hazards from this construction until new flooring is installed. This will be required for the two walls that will be removed. Section 1: wall demolition going into old HR section. Section 2: conference room expansion where wall will be removed.

Addition 2: City staff will be responsible for moving partitions, cubicles, desks, and paperwork prior to construction. After construction, city staff is responsible for returning materials.

Addition 3: Colors for walls and trim will be provided to the lowest responsible bidder. Two different color tones: 1 for walls, and 1 for trims.

Addition 4: New offices shall have their own light switches and work independently.

Addition 5: Wall going into old HR's section that will be removed, must be removed as later as possible in the project. This will serve as a separation from construction area to existing area.

Question 1: Will any fire sprinklers need to be relocated?

Response 1: Fire sprinklers will not need to be replaced or relocated.

Question 2: Can existing door frames and doors be used in new locations? This will save some cost.

Response 2: Yes, doors and door frames can be utilized to save cost if doors swing in the same direction and follow code. Doors can be re-purposed in the following order: (See diagram below)

- Section 1: Existing office door that will be sealed (West wall of office) relocated to north wall of same office.
- Section 1: Door of wall that will be removed to be relocated to one of the three new offices.
- Section 3: Door in current office to be relocated in new storage room.

(3) New doors will be needed at: 2 new offices at section 1 and restroom door at section 3. Contractor to match door by Oshkosh Door, Oshkosh Series. If unable to find the exact door, the new door must be approved by City staff/coordinator.



City of San Luis

Department of Facilities

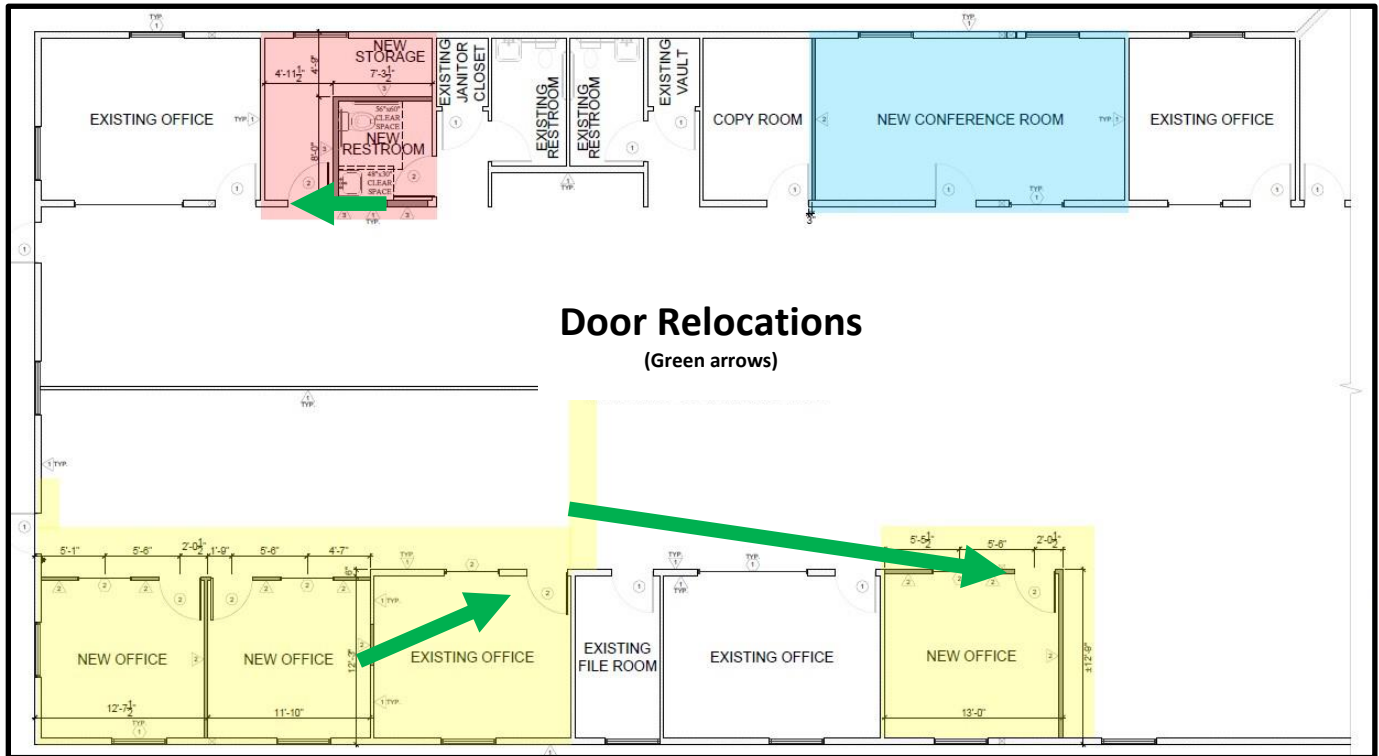

Door Relocations (Green arrows)

Question 3: Will there be someone present after hours to open, close, and supervise?

Response 3: Assigned city staff will be at location only to open facility. There will be no physical supervision other than remote camera access by City staff. On call staff will be available over the phone for any questions. The contractor is responsible for closing facilities once they are done with daily work.

Question 4: Will we need to isolate electricity where partitioners will be removed?

Response 4: Practitioners for this project do not have any electricity going through them. Any reconfigurations must follow Edais Engineering plans.

This Addendum is incorporated into the contract documents. Please acknowledge receipt of this addendum as part of the submittal of bid. All other terms and conditions remain the same.

Edgar Juarez
Facilities Project Coordinator



AGENDA ITEM REVIEW FORM

Regular City Council Meeting

7. C.

Meeting Date: 04/10/2024

Department Head: Eulogio Vera, Director of Public Works, Public Works Department

Submitted By: Jorge Perez, Assistant Director of Public Works, Public Works Department

Action Requested: Motion

ITEM:

Discussion and possible action on any and all matters regarding the acceptance and award of a construction contract to Yuma Valley Contractors, Inc. for the construction of a new concrete two million gallon water storage tank at well site seven. **(Jorge Perez, Assistant Director of Public Works)**

SUMMARY:

The Department of Public Works is seeking Council approval for accepting and awarding a construction contract to Yuma Valley Contractors, Inc., 1334 S. 5th Avenue, Yuma, Arizona 85364, for the construction of a new concrete two million gallon water storage tank at well site seven. Yuma Valley Contractors was the lowest responsible bidder for this project under the tank alternative #2 (Concrete Tank) at \$4,145,983.78. Under alternative #1 (Steel Tank), the lowest bidder was Taylor Engineering at \$4,090,234.05. Public Works and its Water Department evaluated both alternatives, and with the bid tabulation of our engineering consultant, staff is recommending to move forward with the alternative #2 of a concrete tank.

Constructing a concrete tank was more expensive in the past than building a steel tank. By comparing both alternatives (concrete and steel), there is a difference of \$55,749.70. The concrete is slightly higher, but the savings will come from the long-term maintenance. From very recent experience, the Department of Public Works had to rehabilitate two steel tanks, one of them costing around \$600,000.00 and the second one being estimated at close to \$1,000,000.00 due to major roof repairs needed. On the other hand, concrete tanks and structures, in general, will require much less maintenance. Maintenance will be limited to power washing, structural and/or appurtenances upgrades, and periodic engineering testing and inspections (upgrades and inspections are also applicable to steel tanks). Otay Mesa Water District did a comparison/evaluation of periodic maintenance every 15 years for a 2 million gallon on steel and concrete reservoirs/tanks on a 50-year life cycle cost. As a result of that evaluation, the concrete tank maintenance takes only 15% of what it will cost to maintain a steel tank over the 50-year period.

Public Works is seeking Council approval to accept Construction Services from Yuma Valley Contractors, Inc. for this project in the amount of \$4,145,983.78. This purchase falls under the provisions of City Code 3.05.030 Bidding. A 5% contingency is included in the bid.

RECOMMENDATION / SUGGESTED MOTION:

I MOVE TO ACCEPT AND AWARD THE SUCCESSFUL BID TO YUMA VALLEY CONTRACTORS, INC. FOR THE CONCRETE TWO MILLION GALLON WATER STORAGE TANK CONSTRUCTION PROJECT AT WELL SITE #7 NOT TO EXCEED \$4,145,983.78 AND DIRECT STAFF TO FINALIZE THE CONTRACT.

Fiscal Impact

IS THERE FISCAL IMPACT ASSOCIATED WITH THIS ITEM: Yes
CITY/STATE/FEDERAL FUNDS: City
TOTAL: \$4,145,983.78
BUDGETED AMOUNT: See Fiscal Impact
AVAILABLE AMOUNT TO TRANSFER: N/A
ACCT NAME & GL#/REMAINING BALANCE BEFORE PURCHASE: See Fiscal Impact
FISCAL IMPACT STATEMENT (IF THIS IS A BUDGET TRANSFER, YOU MUST ATTACH THE BUDGET ADJUSTMENT FORM):

The department of Public Works has a FY24 budget for this project of \$1,500,000.00. Out of this amount, the full project design and bidding services have been expensed, and the department plans to use about \$300,000.00 before the end of the fiscal year. The remaining balance budgeted for fiscal year 2024 has been reallocated to other projects and purchases with council approval. Public Works is requesting the remaining project balance to be funded for fiscal year 2025.

Attachments

2MG Concrete Water Storage Tank - Bid Tabulation
Proposed Contract

BID TABULATION - WELL SITE 7 - NEW 2 MILLION GALLON WATER STORAGE TANK - ALTERNATIVE 2 - CONCRETE WATER STORAGE TANK

Bid Item	Description	Unit of Measure	Quantities	Bidder No. 1		Bidder No. 2		Bidder No. 3		Bidder No. 4		Bidder No. 5	
				Taylor Engineering		Revolution Industries		Yuma Valley Contractors		Preload LLC		Gutierrez Canales	
				Unit Cost	Total Cost	Unit Cost	Total Cost	Unit Cost	Total Cost	Unit Cost	Total Cost	Unit Cost	Total Cost
1	2.0 Million Gallon AWWA D110 Prestressed Water Storage Tank including Foundation Preparation and Appurtenances	LS	1	\$ 3,148,969.00	\$ 3,148,969.00	\$ 3,009,326.00	\$ 3,009,326.00	\$ 3,160,735.71	\$ 3,160,735.71	\$ 4,127,611.00	\$ 4,127,611.00	\$ 3,577,210.00	\$ 3,577,210.00
2	6" ABC Pavement and Site Grading	SY	917	\$ 38.00	\$ 34,846.00	\$ -	\$ -	\$ 45.97	\$ 42,154.49	\$ 37.00	\$ 33,929.00	\$ 34.23	\$ 31,388.91
3	Sawcut, Remove, and Replace Ex. AC Pavement (4" AC/12" ABC)	SY	20	\$ 431.00	\$ 8,620.00	\$ -	\$ -	\$ 303.44	\$ 6,068.80	\$ 660.00	\$ 13,200.00	\$ 396.60	\$ 7,932.00
4	Sawcut, Remove, and Replace Ex. Vertical Curb and Gutter	LF	6	\$ 1,109.00	\$ 6,654.00	\$ -	\$ -	\$ 505.73	\$ 3,034.38	\$ 1,100.00	\$ 6,600.00	\$ 306.50	\$ 1,839.00
5	Sawcut, Remove, and Replace Ex. Sidewalk	SF	30	\$ 165.00	\$ 4,950.00	\$ -	\$ -	\$ 174.78	\$ 5,243.40	\$ 160.00	\$ 4,800.00	\$ 54.60	\$ 1,638.00
6	10" Dia. C-900 PVC Watermain	LF	764	\$ 74.00	\$ 56,536.00	\$ -	\$ -	\$ 107.18	\$ 81,885.52	\$ 70.00	\$ 53,480.00	\$ 110.93	\$ 84,750.52
7	10" NRS Gate Valve	EA	2	\$ 5,459.00	\$ 10,918.00	\$ -	\$ -	\$ 4,307.99	\$ 8,615.98	\$ 5,300.00	\$ 10,600.00	\$ 4,975.50	\$ 9,951.00
8	10" Dia. 90-Degree DIP Elbow	EA	1	\$ 1,405.00	\$ 1,405.00	\$ -	\$ -	\$ 1,310.53	\$ 1,310.53	\$ 1,300.00	\$ 1,300.00	\$ 2,156.00	\$ 2,156.00
9	10" x 8" DIP Reducer	EA	1	\$ 871.00	\$ 871.00	\$ -	\$ -	\$ 1,144.00	\$ 1,144.00	\$ 800.00	\$ 800.00	\$ 1,911.00	\$ 1,911.00
10	12" Dia. C-900 PVC Watermain	LF	201	\$ 232.00	\$ 46,632.00	\$ -	\$ -	\$ 195.11	\$ 39,217.11	\$ 230.00	\$ 46,230.00	\$ 175.71	\$ 35,317.71
11	12" Dia. Class 53 Ductile Iron Pipe	LF	35	\$ 860.00	\$ 30,100.00	\$ -	\$ -	\$ 231.44	\$ 8,100.40	\$ 830.00	\$ 29,050.00	\$ 196.35	\$ 6,872.25
12	12" NRS Gate Valve	EA	3	\$ 6,150.00	\$ 18,450.00	\$ -	\$ -	\$ 5,244.46	\$ 15,733.38	\$ 6,000.00	\$ 18,000.00	\$ 6,384.00	\$ 19,152.00
13	12" Dia. 22.5-Degree DIP Elbow	EA	2	\$ 1,520.00	\$ 3,040.00	\$ -	\$ -	\$ 2,088.37	\$ 4,176.74	\$ 1,500.00	\$ 3,000.00	\$ 1,660.50	\$ 3,321.00
14	12" DIP Tee	EA	3	\$ 3,220.00	\$ 9,660.00	\$ -	\$ -	\$ 2,599.20	\$ 7,797.60	\$ 3,000.00	\$ 9,000.00	\$ 2,618.67	\$ 7,856.01
15	12" x 12" DIP Cross	EA	2	\$ 3,753.00	\$ 7,506.00	\$ -	\$ -	\$ 3,047.86	\$ 6,095.72	\$ 3,600.00	\$ 7,200.00	\$ 3,248.50	\$ 6,497.00
16	12" x 10" DIP Tee	EA	1	\$ 2,853.00	\$ 2,853.00	\$ -	\$ -	\$ 3,007.45	\$ 3,007.45	\$ 2,800.00	\$ 2,800.00	\$ 3,633.00	\$ 3,633.00
17	12" x 10" DIP Reducer	EA	2	\$ 1,017.00	\$ 2,034.00	\$ -	\$ -	\$ 1,460.70	\$ 2,921.40	\$ 1,000.00	\$ 2,000.00	\$ 1,784.00	\$ 3,568.00
18	12" Blind Flange	EA	1	\$ 854.00	\$ 854.00	\$ -	\$ -	\$ 1,326.44	\$ 1,326.44	\$ 800.00	\$ 800.00	\$ 1,462.00	\$ 1,462.00
19	16" Dia. C-900 PVC Watermain	LF	190	\$ 241.00	\$ 45,790.00	\$ -	\$ -	\$ 335.47	\$ 63,739.30	\$ 230.00	\$ 43,700.00	\$ 291.07	\$ 55,303.30
20	16" Dia. Class 53 Ductile Iron Pipe	LF	31	\$ 1,240.00	\$ 38,440.00	\$ -	\$ -	\$ 455.86	\$ 14,131.66	\$ 1,200.00	\$ 37,200.00	\$ 279.65	\$ 8,669.15
21	16" Rising Stem OS&Y Gate Valve	EA	3	\$ 38,431.00	\$ 115,293.00	\$ -	\$ -	\$ 27,153.65	\$ 81,460.95	\$ 38,000.00	\$ 114,000.00	\$ 43,133.34	\$ 129,400.02
22	16" Dia. 90-Degree DIP Elbow	EA	7	\$ 3,078.00	\$ 21,546.00	\$ -	\$ -	\$ 2,703.10	\$ 18,921.70	\$ 3,000.00	\$ 21,000.00	\$ 2,827.43	\$ 19,792.01
23	16" Dia. 45-Degree DIP Elbow	EA	1	\$ 2,861.00	\$ 2,861.00	\$ -	\$ -	\$ 2,352.51	\$ 2,352.51	\$ 2,800.00	\$ 2,800.00	\$ 5,782.00	\$ 5,782.00
24	16" Dia. 22-1/2-Degree DIP Elbow	EA	2	\$ 2,947.00	\$ 5,894.00	\$ -	\$ -	\$ 2,407.82	\$ 4,815.64	\$ 2,800.00	\$ 5,600.00	\$ 2,352.00	\$ 4,704.00
25	16" DIP Tee	EA	1	\$ 5,550.00	\$ 5,550.00	\$ -	\$ -	\$ 5,255.11	\$ 5,255.11	\$ 5,300.00	\$ 5,300.00	\$ 3,893.00	\$ 3,893.00
26	16" x 12" DIP Reducer	EA	4	\$ 2,405.00	\$ 9,620.00	\$ -	\$ -	\$ 2,494.22	\$ 9,976.88	\$ 2,400.00	\$ 9,600.00	\$ 3,019.75	\$ 12,079.00

- Continued -

BID TABULATION - WELL SITE 7 - NEW 2 MILLION GALLON WATER STORAGE TANK - ALTERNATIVE 2 - CONCRETE WATER STORAGE TANK

				<i>Bidder No. 1</i>		<i>Bidder No. 2</i>		<i>Bidder No. 3</i>		<i>Bidder No. 4</i>		<i>Bidder No. 5</i>	
				<i>Taylor Engineering</i>		<i>Revolution Industries</i>		<i>Yuma Valley Contractors</i>		<i>Preload LLC</i>		<i>Gutierrez Canales</i>	
27	Transition Coupling, any size	EA	2	\$ 2,465.00	\$ 4,930.00		\$ -	\$ 2,811.87	\$ 5,623.74	\$ 2,400.00	\$ 4,800.00	\$ 8,561.00	\$ 17,122.00
28	16" Dia. Flex Tend Double Ball Flexible Expansion Joint	EA	2	\$ 7,213.00	\$ 14,426.00		\$ -	\$ 24,871.61	\$ 49,743.22	\$ 7,000.00	\$ 14,000.00	\$ 10,104.00	\$ 20,208.00
29	Hydrostatic Pressure Instrument	EA	1	\$ 9,479.00	\$ 9,479.00		\$ -	\$ 2,477.14	\$ 2,477.14	\$ 8,000.00	\$ 8,000.00	\$ 13,244.00	\$ 13,244.00
30	Concrete Drain & Tank Overflow Box	LS	1	\$ 17,406.00	\$ 17,406.00		\$ -	\$ 11,530.56	\$ 11,530.56	\$ 17,000.00	\$ 17,000.00	\$ 42,931.00	\$ 42,931.00
31	20" Dia. C-900 PVC Watermain	LF	380	\$ 246.00	\$ 93,480.00		\$ -	\$ 214.08	\$ 81,350.40	\$ 240.00	\$ 91,200.00	\$ 261.58	\$ 99,400.40
32	20" Dia. Class 53 Ductile Iron Pipe	LF	7	\$ 2,590.00	\$ 18,130.00		\$ -	\$ 1,642.32	\$ 11,496.24	\$ 2,500.00	\$ 17,500.00	\$ 1,366.43	\$ 9,565.01
33	20" Rising Stem OS&Y Gate Valve	EA	1	\$ 54,165.00	\$ 54,165.00		\$ -	\$ 39,843.35	\$ 39,843.35	\$ 53,000.00	\$ 53,000.00	\$ 62,075.00	\$ 62,075.00
34	20" Dia. 90-Degree DIP Elbow	EA	4	\$ 4,697.00	\$ 18,788.00		\$ -	\$ 3,747.50	\$ 14,990.00	\$ 4,500.00	\$ 18,000.00	\$ 3,967.00	\$ 15,868.00
35	20" Dia. 45-Degree DIP Elbow	EA	3	\$ 3,755.00	\$ 11,265.00		\$ -	\$ 4,625.34	\$ 13,876.02	\$ 3,600.00	\$ 10,800.00	\$ 3,547.34	\$ 10,642.02
36	20" DIP Tee	EA	1	\$ 7,712.00	\$ 7,712.00		\$ -	\$ 5,878.73	\$ 5,878.73	\$ 7,500.00	\$ 7,500.00	\$ 6,117.00	\$ 6,117.00
37	20" x 16" DIP Reducer	EA	1	\$ 3,551.00	\$ 3,551.00		\$ -	\$ 3,899.56	\$ 3,899.56	\$ 3,500.00	\$ 3,500.00	\$ 3,288.00	\$ 3,288.00
38	20" Dia. DIP Blind Flange	EA	1	\$ 2,706.00	\$ 2,706.00		\$ -	\$ 2,881.01	\$ 2,881.01	\$ 2,600.00	\$ 2,600.00	\$ 2,436.00	\$ 2,436.00
39	20" Dia. Flex Tend Double Ball Flexible Expansion Joint	EA	1	\$ 46,876.00	\$ 46,876.00		\$ -	\$ 34,618.06	\$ 34,618.06	\$ 45,000.00	\$ 45,000.00	\$ 45,732.00	\$ 45,732.00
40	Electrical and Instrumentation	LS	1	\$ 64,723.00	\$ 64,723.00		\$ -	\$ 52,648.22	\$ 52,648.22	\$ 55,000.00	\$ 55,000.00	\$ 195,160.00	\$ 195,160.00
41	Storm Water Pollution Prevention Plan	LS	1	\$ 2,586.00	\$ 2,586.00		\$ -	\$ 6,460.88	\$ 6,460.88	\$ 2,500.00	\$ 2,500.00	\$ 15,896.00	\$ 15,896.00
42	Construction Staking and Layout	LS	1	\$ 24,989.00	\$ 24,989.00		\$ -	\$ 12,016.05	\$ 12,016.05	\$ 16,000.00	\$ 16,000.00	\$ 13,860.00	\$ 13,860.00
Subtotal				\$ 4,035,104.00				\$ 3,948,555.98		\$ 4,976,000.00		\$ 4,619,622.31	
5% Contingency				\$ 201,755.20				\$ 197,427.80		\$ 248,800.00		\$ 230,981.12	
Total Bid				\$ 4,236,859.20				\$ 4,145,983.78		\$ 5,224,800.00		\$ 4,850,603.43	



City of San Luis

Department of Public Works

• Administration • Streets • Water • Wastewater • Solid Waste • Fleet Services •

AGREEMENT

For the Construction of

**City of San Luis
WELL SITE 7
NEW 2 MILLION GALLON WATER STORAGE TANK**

This agreement (“AGREEMENT”) is made and entered into this ____ day of April 2024, by and between:

Yuma Valley Contractors, Inc. 1334 S. 5 th Avenue Yuma, Arizona 85364 An Arizona for-profit limited liability company (“CONTRACTOR”) and	City of San Luis 1090 East Union Street (Physical Address) P.O. Box 3750 (Mailing Address) San Luis, Arizona 85349 An Arizona municipal corporation organized (“OWNER”)
---	--

The CONTRACTOR and OWNER may be referred to individually as the Party and collectively as the Parties.

In consideration of the OWNER paying the sum of \$4,145,983.78 to the CONTRACTOR, and the CONTRACTOR constructing a new 2 million gallon water storage tank with appurtenances and piping at the City’s Well Site 7 and other work incidental to the project in the manner and at the time provided in this AGREEMENT, and in consideration of the other mutual benefits and obligations contained in the AGREEMENT, the parties agree as follows:

ARTICLE I – SCOPE OF WORK: The CONTRACTOR shall furnish any and all labor, materials, equipment, transportation, utilities, services, and facilities required to perform all work for the **City of San Luis – Well Site 7 New 2 Million Gallon Water Storage Tank Project** (“PROJECT”), per the CONTRACTOR’s bid alternative #2, Concrete Water Storage Tank of March 26, 2024, (“PROPOSAL”). and to completely and totally remove and install the materials therein for the OWNER, in a good and workmanlike and substantial manner and to the satisfaction of the OWNER through its engineers (“ENGINEERS”) and under the direction and supervision of the ENGINEERS, or his properly authorized agents and strictly pursuant to and in conformity with the plans and specification prepared by the ENGINEERS, and with such modifications of the same and other documents that may be made by the OWNER through the ENGINEERS or his properly authorized agents, as provided herein.

ARTICLE II – EFFECTIVE DATE: This AGREEMENT becomes effective upon the ENGINEER’S notice to proceed.

ARTICLE III – CONTRACT DOCUMENTS: The advertisement for bids, bid schedule, additive bid items, if any, specifications, general conditions, special provisions, addenda, if any, proposal, BID SURETY BOND, City of San Luis Supplemental to the MAG Uniform Standard Specifications and Details for Public Works Construction and City of Yuma Construction Standard Detail Drawings, Maricopa Association of Governments (MAG) Uniform Standard Specifications and Details for Public Works Construction, City of Yuma Construction Standard Detail Drawings – Edition 2019, CONTRACT SURETY BOND, LABOR AND MATERIALS SURETY BOND, Certificates of Insurance, and Change Orders, if any, are by this reference made a part of this CONTRACT to the same extent as if set forth herein in full.



City of San Luis

Department of Public Works

• Administration • Streets • Water • Wastewater • Solid Waste • Fleet Services •

ARTICLE IV – ARIZONA WORKERS ACT COMPLIANCE: To the extent applicable under A.R.S. § 41-4401, the CONTRACTOR and its subcontractors warrant compliance with the federal immigration laws and regulations that relate to their Employees and compliance with the E-Verify requirements under A.R.S. § 23-214(A). The CONTRACTOR or subcontractors' breach of the above-mentioned warranty shall be deemed a material breach of the AGREEMENT and may result in the termination of the Agreement by OWNER. OWNER retains the legal right to randomly inspect the papers and records of the CONTRACTOR and its subcontractors who work on the Agreement to ensure that the CONTRACTOR and its subcontractors are complying with the above-mentioned warranty. The CONTRACTOR and its subcontractors warrant to keep the papers and records open for inspection during normal business hours by OWNER and to cooperate with OWNER'S inspections.

ARTICLE V – INDEPENDENT CONTRACTOR: The parties intend that this AGREEMENT will create an independent contractor relationship and not an employer-employee relationship. The OWNER is interested only in the results to be achieved, and the conduct and control of the performance of the services contemplated under this AGREEMENT will be solely with the CONTRACTOR. CONTRACTOR's employees, agents, and subcontractors shall not be considered to be employees or agents of the OWNER for any purpose. They shall not be entitled to any of the benefits the OWNER provides for its employees. CONTRACTOR shall furnish at its own expense all materials and equipment necessary to carry out the terms of this AGREEMENT.

The rights of the CONTRACTOR as an independent contractor include but are not limited to control of the work, manner, and methods of the work, and the right to contract with other employers.

The rights of the OWNER include but are not limited to inspection and approval of the work and the right to contract with others to perform the work.

ARTICLE VI – CERTIFICATION:

- A. **SAFETY.** The CONTRACTOR expressly agrees that it shall be solely responsible for supervising its employees and that it shall comply with all rules, regulations, orders, standards, and interpretations promulgated pursuant to the federal Occupational Safety and Health Act (known as OSHA) and any occupational safety and health act of Arizona including but not limited to training provisions of personal protective equipment; adherence to all appropriate lockout-tagout procedures and providing all notices, safety data sheets, etc., as required by the right-to-know standard.
- B. **NO BOYCOTT OF ISRAEL.** The CONTRACTOR certifies, to the extent permitted by law, that it does not participate in and agrees not to participate in during the term of this AGREEMENT in a boycott of Israel under A.R.S. § 35-393.01.
- C. **NO FORCED LABOR OF THE ETHNIC UYGHURS.** Under A.R.S. § 35-394, CONTRACTOR certifies, to the extent permitted by law, that it does not currently, and agrees for the duration of this AGREEMENT that it will not, use:
 1. The forced labor of ethnic Uyghurs in the People's Republic of China.
 2. Any goods or services produced by the forced labor of ethnic Uyghurs in the People's Republic of China.
 3. Any contractors, subcontractors or suppliers that use the forced labor or any goods or services produced by the forced labor of ethnic Uyghurs in the People's Republic of China.



City of San Luis

Department of Public Works

• Administration • Streets • Water • Wastewater • Solid Waste • Fleet Services •

By signing this AGREEMENT, the CONTRACTOR certifies in writing that if the CONTRACTOR becomes aware during the term of the AGREEMENT that the CONTRACTOR is not in compliance with the written certification, the CONTRACTOR shall notify the OWNER within five business days after becoming aware of the noncompliance. If the CONTRACTOR does not provide the OWNER with a written certification that the CONTRACTOR has remedied the noncompliance within one hundred eighty days after notifying the OWNER of the noncompliance, the AGREEMENT terminates, except that if the AGREEMENT termination date occurs before the end of the remedy period, the AGREEMENT terminates on the AGREEMENT termination date.

ARTICLE VII – CONFLICT OF INTEREST: All parties hereto acknowledge that this agreement is subject to cancellation pursuant to the provisions of A.R.S. § 38-511.

ARTICLE VIII – TIME OF COMPLETION: The CONTRACTOR further covenants and agrees at his own proper cost and expense, to do all work as aforesaid for the construction of said improvements and to completely construct the same and install the material therein, as called for by this agreement free and clear of all claims, liens, and charges whatsoever, in the manner and under the conditions specified within the time, or times, stated in the PROPOSAL **270 calendar days** from date of Notice to Proceed.

ARTICLE IX – PAYMENTS: For and in consideration of the faithful performance of the work herein embraced as set forth in the CONTRACT DOCUMENTS, which are a part hereof and in accordance with the directions of the Owner, through its Engineer, and to his satisfaction, the Owner agrees to pay the said CONTRACTOR the amount earned, computed from actual quantities of work performed and accepted or materials furnished at the unit bid price on the PROPOSAL made a part hereof, and to make such payments within forty-five (45) days after final inspection and acceptance of the work.

ARTICLE X – INDEMNIFICATION: The CONTRACTOR, by this AGREEMENT, agrees to indemnify, save harmless, and defend the OWNER (the City of San Luis) and any jurisdiction or agency issuing permits for any work included in the PROJECT, their elected officials, officers, employees, agents, and representatives from all suits, action, loss, damage, expense, cost, or claims of any character or any nature brought on account of any injuries or damage sustained by any person or property arising out of the work done in fulfillment of the construction of the improvement under the terms of this AGREEMENT, or on account of any act or omission by the CONTRACTOR or his agents, or from any claims of amounts arising or recovered under Workmen's Compensation laws or any other law, bylaw, ordinance, order, or decree. This indemnification includes but is not limited to reasonable attorney fees, court costs, the costs of appellate proceedings, and all claim adjusting and handling expenses.

ARTICLE XI – SURVIVAL: All of the CONTRACTOR's representations and warranties, indemnity, hold harmless, and defense obligations shall survive the expiration or earlier termination of this AGREEMENT.

ARTICLE XII – CONTRACTOR'S INSURANCE: The limits of liability for the insurance required shall provide coverage for not less than the following amounts or greater amounts where required by laws and regulations:

A. WORKERS' COMPENSATION AND RELATED COVERAGES:

- | | |
|---------------------------|-----------|
| 1. State: | Statutory |
| 2. If Applicable, Federal | Statutory |
| 3. Employer's Liability: | \$500,000 |



City of San Luis

Department of Public Works

• Administration • Streets • Water • Wastewater • Solid Waste • Fleet Services •

B. CONTRACTOR'S GENERAL LIABILITY: CONTRACTOR's General Liability coverage shall include completed operations and product liability coverage. The CONTRACTOR's General Liability coverage shall include and eliminate the exclusion for property under the care, custody, and control of the CONTRACTOR:

1. General Aggregate	\$6,000,000
2. General Each Occurrence	\$6,000,000
3. Products and Completed Operations Aggregate	\$2,000,000
4. Personal Injury and Advertising Injury	\$2,000,000
5. Each Occurrence (Bodily Injury and Property Damage)	\$2,000,000

Property Damage liability insurance will provide Explosion, Collapse, and Underground coverages Where applicable.

6. Excess and Umbrella Coverage

C. AUTOMOBILE LIABILITY:

1. Bodily Injury:	
Each person	\$1,000,000
Each Accident	\$1,000,000
2. Property Damage:	
Each Accident	\$1,000,000
3. Combined Single Limit	\$1,000,000
4. The Contractual Liability coverage required shall provide coverage for not less than the following amounts:	
5. Bodily Injury:	
Each person	\$2,000,000
Each Accident	\$2,000,000
6. Property Damage:	
Each Accident	\$2,000,000
Annual Aggregate	\$2,000,000
7. Professional Liability Errors and Omissions	\$1,000,000

D. OTHER PERSONS OR ENTITIES TO BE INCLUDED ON THE POLICIES AS ADDITIONAL INSURED:
The CONTRACTOR shall file a certificate of insurance and endorsements compliant with this AGREEMENT naming the OWNER as an additional insured except for Workers' Compensation and Professional Liability Errors and Omissions. The Insurance the CONTRACTOR maintains under this AGREEMENT shall be primary and non-contributory. Any coverage maintained by the OWNER shall not contribute to any claims arising from the CONTRACTOR's performance of this AGREEMENT. The CONTRACTOR shall file these certificates with OWNER's Public Works Department within ten (10) days of execution of this AGREEMENT and prior to engaging in any operation or activities set forth in this AGREEMENT. The foregoing insurance policies shall provide that no cancellation, major change in coverage, or expiration by the insurance company or the insured



City of San Luis

Department of Public Works

• Administration • Streets • Water • Wastewater • Solid Waste • Fleet Services •

during the term of this AGREEMENT shall occur without thirty (30) days' written notice to the OWNER's Public Works Department prior to the effective date of such cancellation or change in coverage. The CONTRACTOR shall provide that its coverage shall provide for the following additional insureds:

1. City of San Luis, Arizona, including its elected officials, officers, employees, and agents; and
2. Pacific Advanced Civil Engineering, Inc. (a California Corporation registered in Arizona)

E. DEDUCTIBLE OR SELF-INSURED RETENTIONS

If the policies provide coverage that contains deductible or self-insured retentions, such deductible or self-insured retentions are not applicable with respect to the coverage provided to the OWNER under such policies. The CONTRACTOR is solely responsible for deductible or self-insured retention, and the OWNER

may require the CONTRACTOR to secure the payment of such deductible or self-insured retentions by a surety bond or an irrevocable and unconditional letter of credit.

ARTICLE XIII – AMENDMENT OF THE AGREEMENT: Neither Party shall change or add to this AGREEMENT except by written amendment executed by the Parties.

ARTICLE XIV – FORCE MAJEURE: If the CONTRACTOR or the OWNER or both are prevented or materially restricted from performing any of their obligations under this AGREEMENT by an event of *force majeure*, then the obligations of each Party shall be suspended or reduced to the extent made necessary by the event. As used in this section, "*force majeure*" means any act or cause not reasonably within the control of the Party whose ability to perform is impaired and which that Party could not have prevented by the exercise of reasonable diligence. *Force majeure* events include but are not limited to acts of God, fire, flood, explosions, strikes (or labor disputes) over which the affected Party has no control, sabotage, riots, civil commotion, acts of civil or military authority, wars, or material changes in applicable business laws (including but not limited to through statutes, regulations, executive orders, or emergency declarations and proclamations).

ARTICLE XV – NOTICES:

- A. All notices and communications provided for in this AGREEMENT or given in connection with this AGREEMENT shall be validly given and fully received when in compliance with all of the following:
 1. In writing,
 2. Delivered or refused delivery,
 3. By personal delivery, or by major commercial delivery courier service which requires a signature of the recipient, or by registered or certified United States Postal Service mail, return receipt requested with the signature of the recipient, postage prepaid to the addresses in the first paragraph of this AGREEMENT.
- B. Either Party may designate in writing and deliver notice of a different address in the same way as above. Any such change of address notice shall be delivered at least ten (10) days before the date on which the change is to become effective.
- C. Notices for delivery to the OWNER shall be to the attention of the Public Works Director, copies to the City Manager, City Attorney, and City Clerk.



City of San Luis

Department of Public Works

• Administration • Streets • Water • Wastewater • Solid Waste • Fleet Services •

- D. Notices for delivery to the CONTRACTOR shall be to the attention of Kyle Wade, Construction Manager, 1334 S. 5th Avenue, Yuma, Arizona 85364 (or successor statutory agent).

ARTICLE XVI – SUCCESSOR AND ASSIGNS: This AGREEMENT is not assignable unless both Parties mutually consent otherwise in writing. The requirements of this AGREEMENT are binding upon the heirs, executors, administrators, successors, and assigns of both Parties.

ARTICLE XVII – GOVERNING LAW: The laws of the State of Arizona govern this AGREEMENT in all substantive respects, including but not limited to validity, interpretation, and performance of the AGREEMENT. Arizona law shall govern all procedural aspects of enforcing or performing this AGREEMENT, including but not limited to court procedures and choice of law.

ARTICLE XVIII – WAIVER: If either Party fails to require the other Party to perform any provision of this AGREEMENT, that failure does not prevent the Party from later enforcing that provision. Neither Party is released from any responsibilities or obligations imposed by law or this AGREEMENT if the other Party fails to exercise a right or remedy.

ARTICLE XIX – SEVERABILITY: If any terms, parts, or provisions of this AGREEMENT are for any reason invalid or unenforceable, the remaining terms, parts, or provisions are nevertheless valid and enforceable.

ARTICLE XX – INTEGRATION: This AGREEMENT contains the entire agreement between the Parties, and no oral or written statement, promise, or inducement made by either Party or its agents not contained or specifically referred to in this AGREEMENT is valid or binding. All modifications to this AGREEMENT must be in writing, signed, and endorsed by the Parties.

ARTICLE XXI – NO PARTNERSHIP: Nothing in this AGREEMENT constitutes a partnership or joint venture between the Parties, and neither Party is the principal or agent of the other.

ARTICLE XXII – NO THIRD-PARTY BENEFICIARIES: There are no third-party beneficiaries to this AGREEMENT, and no person or entity, not a Party, shall have any right or cause of action under this AGREEMENT.

ARTICLE XXIII – VENUE, COSTS, AND FEES: The Parties must institute and maintain any legal actions or other judicial proceedings arising from this AGREEMENT in a court of competent jurisdiction located in Yuma County, Arizona. The Party prevailing in any such action or other proceeding to resolve a dispute shall be paid all reasonable costs, reasonable expert services fees, and reasonable attorney's fees by the other Party. In the event any judgment is secured by said prevailing Party, all such costs, expert fees, and attorney's fees shall be included in the judgment, such fees to be set by the court and not by jury.

ARTICLE XXIV – COMPLIANCE WITH ALL LAW: The CONTRACTOR must comply with all federal, state, and local laws and regulations applicable to its performance under this AGREEMENT, including but not limited to:

- A. The CONTRACTOR will comply with the Americans with Disabilities Act (A.D.A.) and will indemnify the OWNER for any costs, including but not limited to damages, attorney's fees, and staff time in any action or proceeding brought alleging violation of the A.D.A.



City of San Luis

Department of Public Works

• Administration • Streets • Water • Wastewater • Solid Waste • Fleet Services •

- B. The CONTRACTOR will not discriminate against any person on the basis of race, religion, color, age, sex, or national origin in the performance of this AGREEMENT and must comply with the terms and intent of Title VII of the Civil Rights Act of 1964, P.L. 88-354 (1964) as amended.
- C. The CONTRACTOR agrees not to participate in or cooperate with an international boycott, as defined in 26 U.S.C. § 999 (b)(3) and (4) of the Internal Revenue Code of 1954, as amended, or engage in conduct declared to be unlawful by Arizona state law.

In addition, the CONTRACTOR must include similar requirements of all subcontractors in contracts entered for the performance of the CONTRACTOR's obligations under this AGREEMENT.

ARTICLE XXV – SAN LUIS BUSINESS LICENSE. The CONTRACTOR shall obtain a San Luis Business License before commencing work.

ARTICLE XXVI – TIME OF THE ESSENCE: Time is of the essence in this AGREEMENT. Unless otherwise specifically provided, any consent to delay in the CONTRACTOR's performance of its obligation is applicable only to the particular transaction to which it relates and is not applicable to any other obligation or transaction.

ARTICLE XXVII – HEADINGS: The headings of this AGREEMENT are solely for the convenience of the Parties and shall not be used to explain, modify, simplify, or aid in the interpretation of the provisions of this AGREEMENT.

ARTICLE XXVIII – FURTHER ACTS: Each of the Parties shall execute and deliver all such documents and perform all such acts as reasonably necessary, from time to time, to carry out the matters contemplated by this AGREEMENT.

ARTICLE XXIX – COUNTERPARTS: This AGREEMENT may be executed in one or more counterparts, each of which shall be deemed an original, but all of which together shall constitute one and the same instrument. The signature pages from one or more counterparts may be removed from such counterparts. Such signature pages may all be attached to a single instrument so that the signatures of all Parties may be physically attached to a single document.

ARTICLE XXX – AUTHORITY: Each Party represents and warrants to the other Party: (i) that such Party is duly organized and validly existing under the laws of the State of Arizona and has full corporate power and authority to enter into this AGREEMENT and to carry out the provisions of this AGREEMENT; (ii) such Party is duly authorized to execute and deliver this AGREEMENT and to perform its obligations under this AGREEMENT; (iii) the person executing this AGREEMENT on such Party's behalf has been duly authorized to do so by all requisite corporate action, and (iv) this AGREEMENT is a legal and valid obligation binding upon the Parties and enforceable in accordance with its terms.

The Parties have executed this AGREEMENT in Yuma County, Arizona, on the day and year set forth above, which is the day the last Party signed this AGREEMENT. The original AGREEMENT will be filed with the City of San Luis Clerk. The CONTRACTOR agrees that this AGREEMENT, as negotiated, is for the stated work and understands that payment for the total work will be made on the basis of the indicated amount. The OWNER shall pay to the CONTRACTOR, as full consideration for the faithful performance of the AGREEMENT, subject to any additions or deductions as provided in the PROJECT documents, the sum of \$4,145,983.78.



City of San Luis

Department of Public Works

• Administration • Streets • Water • Wastewater • Solid Waste • Fleet Services •

City of San Luis, Arizona

Jenny Torres, Acting City Manager

Date: _____

Attest:

Sonia Cornelio, City Clerk

Approved As to Form:

Kay Marion Macuil, City Attorney

Yuma Valley Contractors, Inc.

Kirk Perkins, Vice-President

Date: _____



AGENDA ITEM REVIEW FORM

Regular City Council Meeting

7. D.

Meeting Date: 04/10/2024

Department Head: Jose A. Guzman, Director of Development Services, Development Services

Submitted By: Juan Tejeda, Associate Planner, Development Services, Planning & Zoning

Action Requested: Motion

Public Hearing

ITEM:

Public hearing followed by discussion and possible action on any and all matters regarding Conditional Use Permit Case No. 2024-0039 - Colibri Self Storage; a request by Riedel Holdings LLC, owner, for a Conditional Use Permit from Section 18.35.030 (C)(10) of the City of San Luis Zoning Ordinance to allow a mini storage, located at 4834 E County 24th Street in San Luis, Arizona. **(Jose A. Guzman, Director of Development Services)**

A. Open Public Hearing

1. Presentation by staff and/or applicant
2. Call to the Public on this item

B. Close Public Hearing

C. Action on Conditional Use Permit Case No. 2024-0039

SUMMARY:

The applicant is requesting the development of a self-storage complex on a property zoned Community Commercial (C-2). Section 18.35.30(C)(10) of the City of San Luis Zoning Ordinance allows mini-storage facilities, except that no outdoor open storage will be allowed. The applicant is proposing a total of 83 self-storage units ranging in sizes from 8'x15' to 10'x20'.

ANALYSIS:

The subject property is located in the Plaza Colibri Commercial Subdivision, Assessor's parcel 778-58-197.

Existing Adjacent Zoning Districts:

To the north R-2 (Los Mezquites Townhomes)

To the west C-2 (Plaza Colibri Commercial Subdivision)

To the south R-3 (Vacant Land)

To the east C-2 (Plaza Colibri Commercial Subdivision)

REVIEW(S):

As part of the review process, all land use cases are reviewed by various city and outside agencies. As required by state statute, staff sent notification letters to property owners within 300 feet of the proposed project (three (3) letters). The city has not received any other significant concerns or objections from the various review agencies or adjacent property owners.

CITIZEN REVIEW MEETING:

As required by state statute and City Code, a Citizen Review meeting was held at City Hall on March 5, 2024, at the City Hall Chambers at 6:00 p.m. The intent of this meeting was to allow the public to learn

about the project, ask questions, and express any comments. Nobody from the public was present during the meeting.

PLANNING AND ZONING COMMISSION MEETING:

The Planning and Zoning Commission held a public hearing on this item at their regular meeting on March 12, 2024, at the Council Chambers of the City of San Luis. The commission agreed with the recommendation of staff and forwarded this case to the City Council with the recommendation of approval with conditions as presented by staff.

STAFF RECOMMENDATION:

The applicant has provided the information and materials necessary for the review of the Conditional Use Permit.

Staff recommends approval of Conditional Use Permit Case No. 2024-0039 subject to the following conditions:

1. Development shall comply with the City of San Luis Zoning Regulations, Building Code Requirements, Public Works Standards, and any applicable regulations for commercial development.
2. The applicant/owner shall submit a Trip Generation Memo for the proposed development to determine if the proposed use generates 100 or more trips during the peak hour. If 100 or more trips are generated during the peak hour, the applicant/owner shall submit a traffic study during the building permit review, and all improvements recommended by the traffic study that are caused by the proposed development shall be constructed by the developer to the satisfaction of the Public Works Director.

RECOMMENDATION / SUGGESTED MOTION:

A. I MOVE TO OPEN PUBLIC HEARING

1. Presentation by staff
2. Call to the public on this item

B. I MOVE TO CLOSE THE PUBLIC HEARING

C. I MOVE TO APPROVE CONDITIONAL USE PERMIT CASE NO. 2024-0039 SUBJECT TO THE CONDITIONS OF APPROVAL AS PRESENTED BY STAFF.

Fiscal Impact

IS THERE FISCAL IMPACT ASSOCIATED WITH THIS ITEM:	n/a
CITY/STATE/FEDERAL FUNDS:	n/a
TOTAL:	n/a
BUDGETED AMOUNT:	n/a
AVAILABLE AMOUNT TO TRANSFER:	n/a
ACCT NAME & GL#/REMAINING BALANCE BEFORE PURCHASE:	n/a
FISCAL IMPACT STATEMENT (IF THIS IS A BUDGET TRANSFER, YOU MUST ATTACH THE BUDGET ADJUSTMENT FORM):	
	n/a

Attachments

Location Map
Site Plan
Applicant Narrative

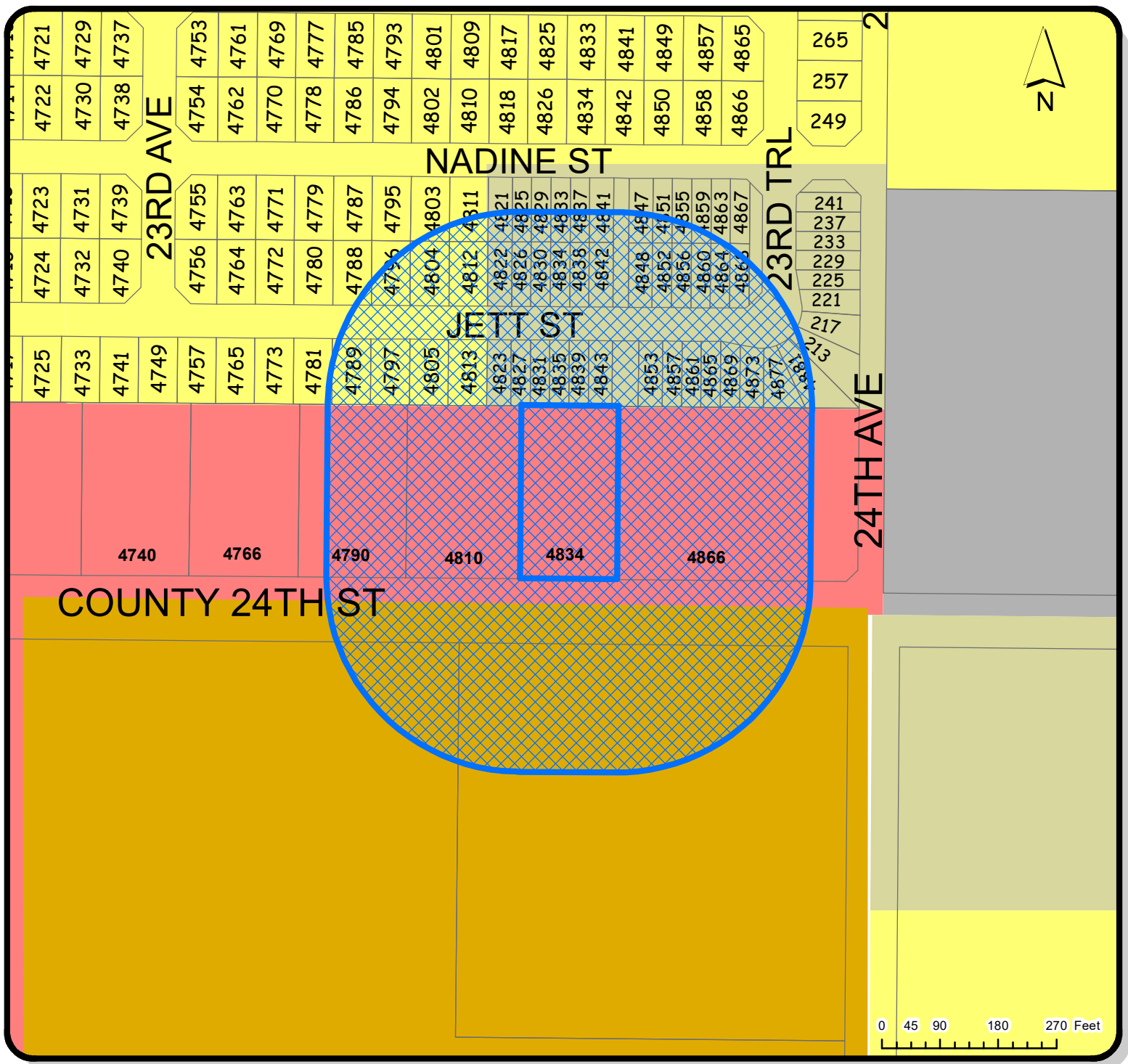











LOCATION OF SUBJECT PROPERTY

 **PARCEL ID: 77858197**
4834 E COUNTY 24TH ST

 **300ft Notification Area**

LOCATION MAP

- Legend**
-  SINGLE RESIDENCE ZONING DISTRICTS
 -  R1-6
 -  RA-10
 -  MULTIPLE RESIDENCE ZONING DISTRICTS
 -  R-2
 -  R-3
 -  COMMERCIAL ZONING DISTRICTS
 -  C-2
 -  INDUSTRIAL ZONING DISTRICTS
 -  LI

CONDITIONAL USE

CASE #
2024-0039

DATE:
2/14/2024

CHECKED BY:
JUAN TEJEDA

PLANNING & ZONING



GIS

CREATED BY:
ISAAC GUTIERREZ

APPROVED BY:
JOSE A. GUZMAN

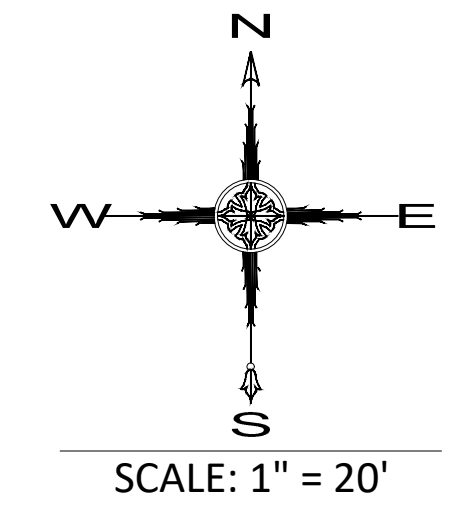
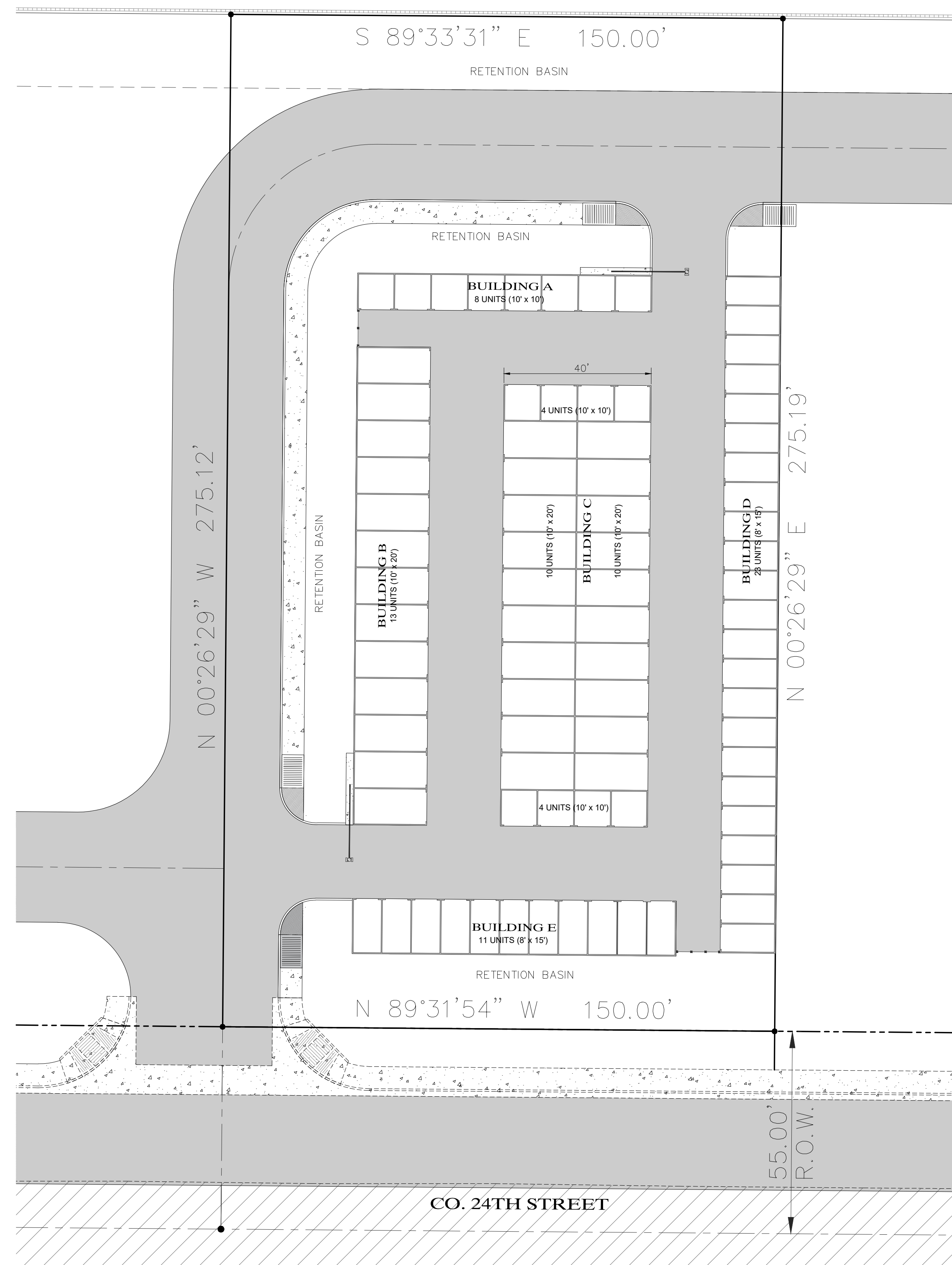

SELF STORAGE BUILDINGS COUNT	
UNIT SIZE	NO. UNITS
10' x 20'	33
10' x 10'	16
8' x 15'	34
TOTAL	83

REVISIONS	

LOT 37 PLAZA
COLIBRI
COMMERCIAL
SUBDIVISION

SITE PLAN

COLIBRI
SELF STORAGE



PRELIMINARY
NOT FOR
CONSTRUCTION

DATE:
JANUARY 2024
DRAWN:
LPR
CHECKED:
NKE
PROJECT:
24-005

SHEET NUMBER
C

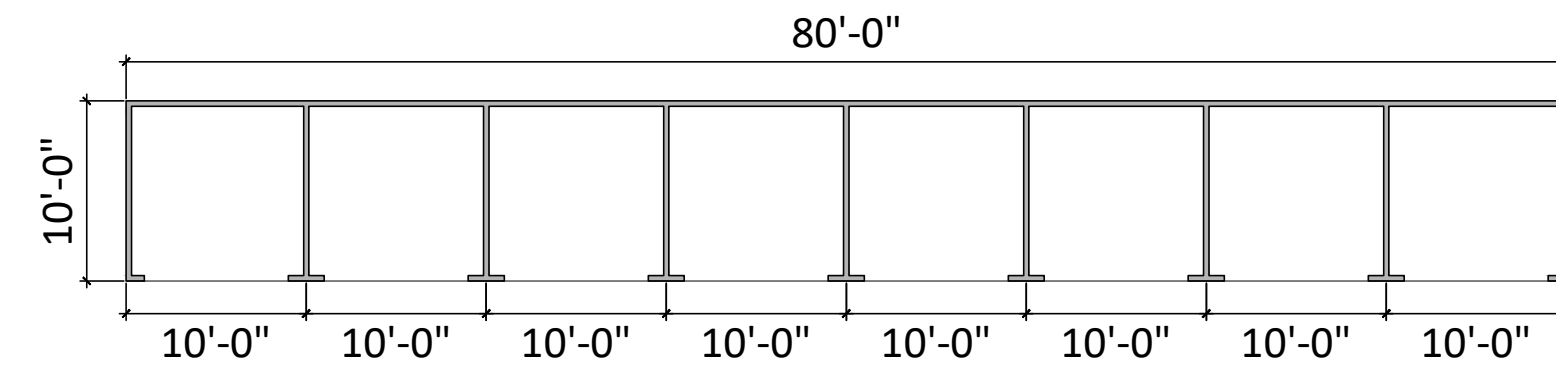

BUILDING A FLOOR PLAN
 (8) 10 x 10 UNITS SCALE: 3/32"=1'-0"

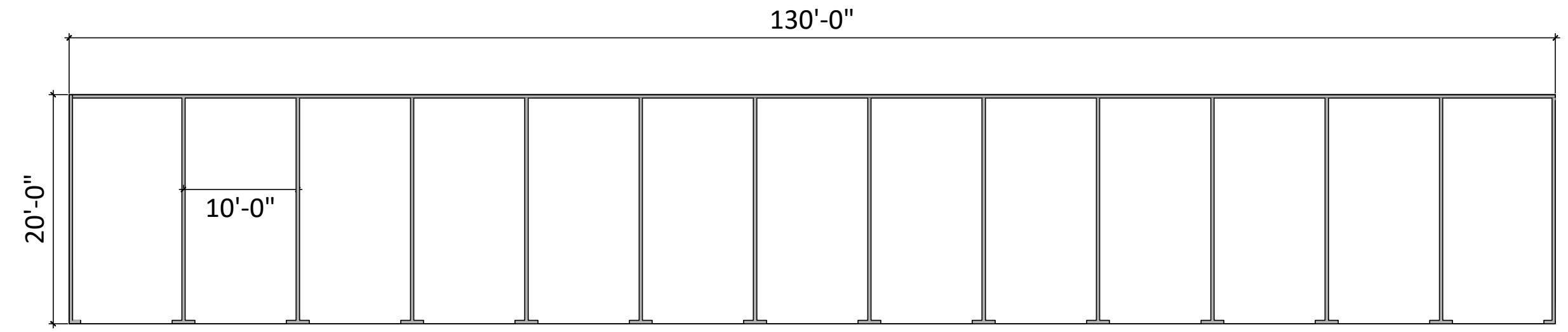

BUILDING B FLOOR PLAN
 (13) 10 x 20 UNITS SCALE: 3/32"=1'-0"

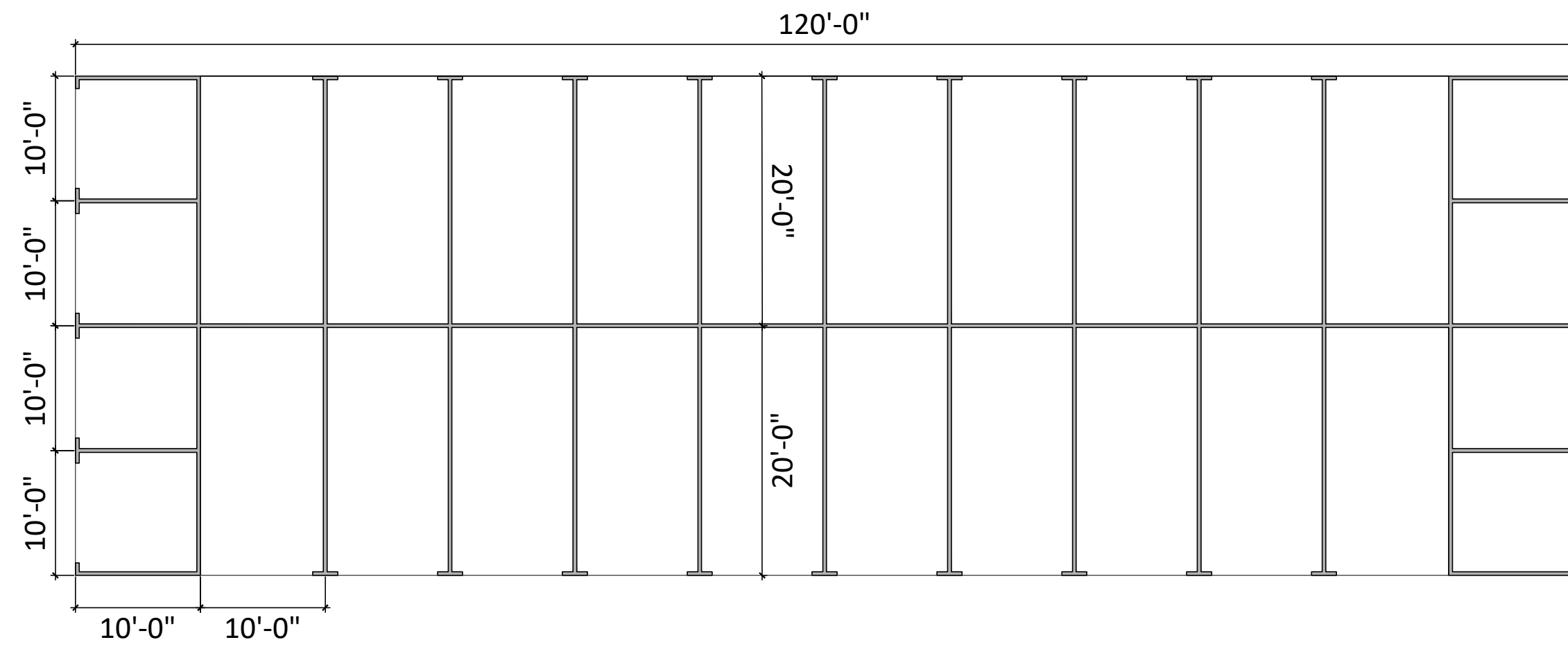

BUILDING C-F FLOOR PLAN
 (20) 10 x 20 UNITS SCALE: 3/32"=1'-0"
 (8) 10 x 10 UNITS

BUILDING FLOOR PLAN
 SCALE: 3/32"=1'-0"

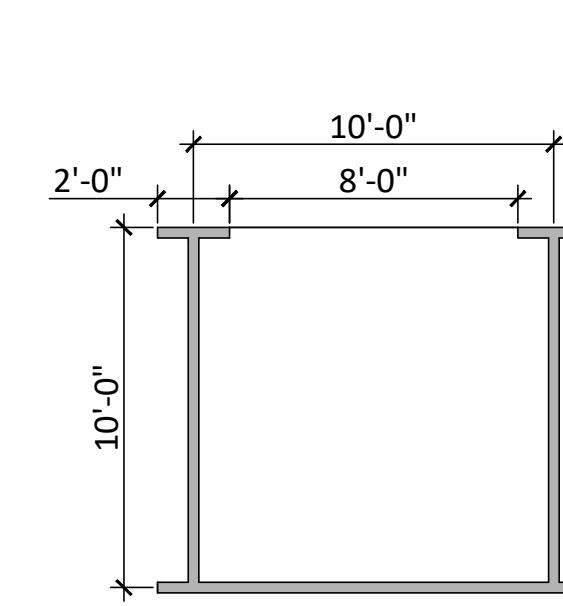

TYP. 10'X10' STORAGE UNIT
 SCALE: 3/16"=1'-0"

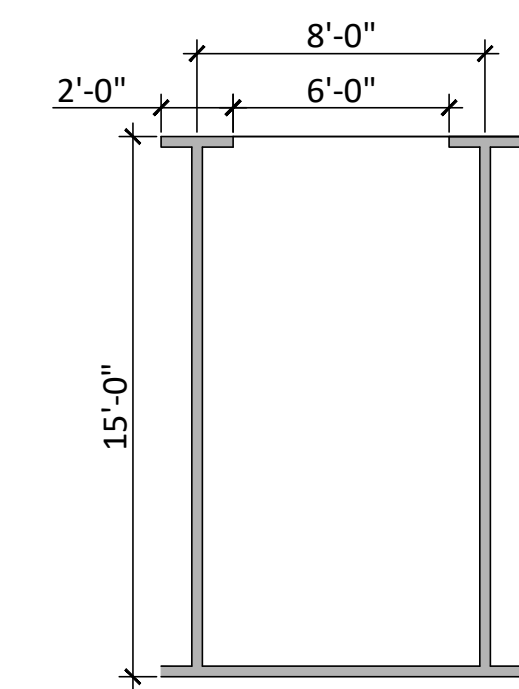

TYP. 8'X15' STORAGE UNIT
 SCALE: 3/16"=1'-0"

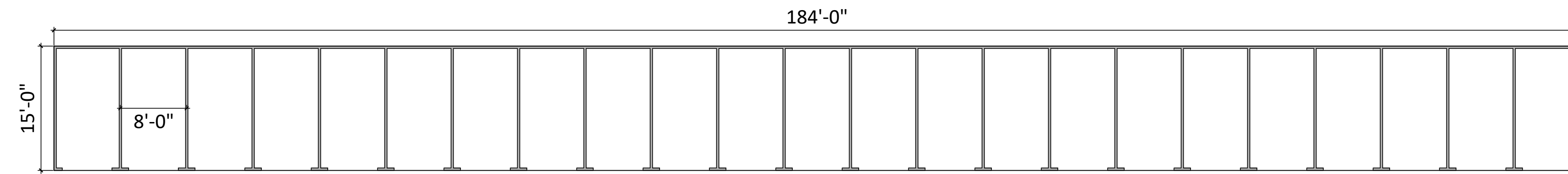

BUILDING D FLOOR PLAN
 (23) 8 x 15 UNITS SCALE: 3/32"=1'-0"

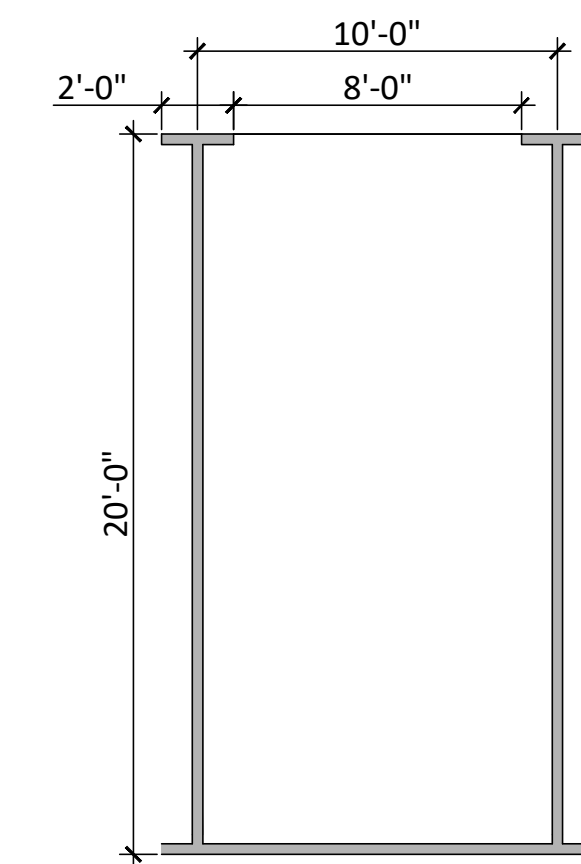

TYP. 10'X20' STORAGE UNIT
 SCALE: 3/16"=1'-0"

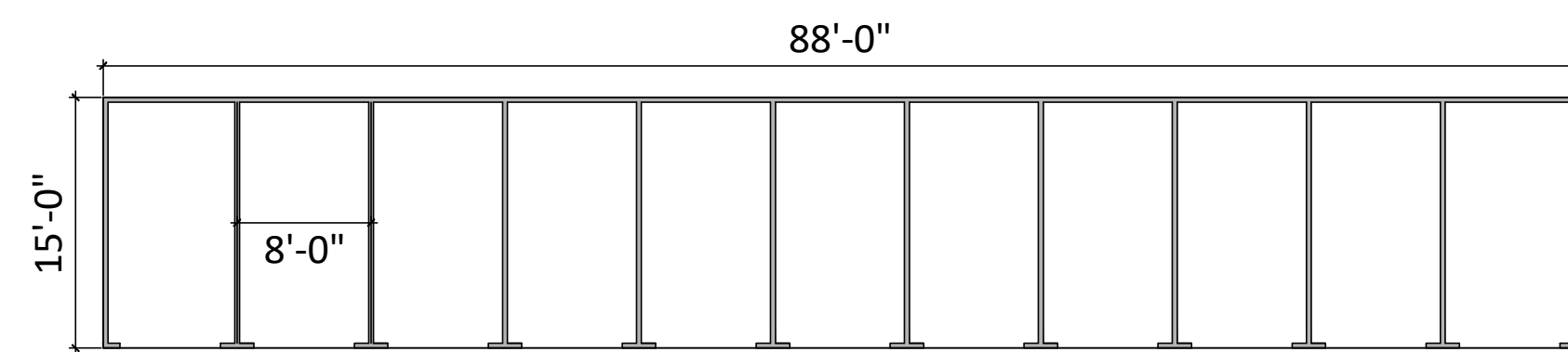

BUILDING E FLOOR PLAN
 (11) 8 x 15 UNITS SCALE: 3/32"=1'-0"

REVISIONS	
▲	
▲	
▲	
▲	
▲	

LOT 37
 PLAZA COLIBRI
 COMMERCIAL
 SUBDIVISION

FLOOR PLAN

COLIBRI SELF
 STORAGE

EDAIS
 Engineering, Inc.
 1000 W. Camelback Road, Suite 100
 Phoenix, Arizona 85008
 (602) 344-3566
 www.edaisengineering.com

DATE:
 JANUARY 2024
 DRAWN:
 LPR
 CHECKED:
 NKE
 PROJECT:
 24-005

SHEET NUMBER
 A1

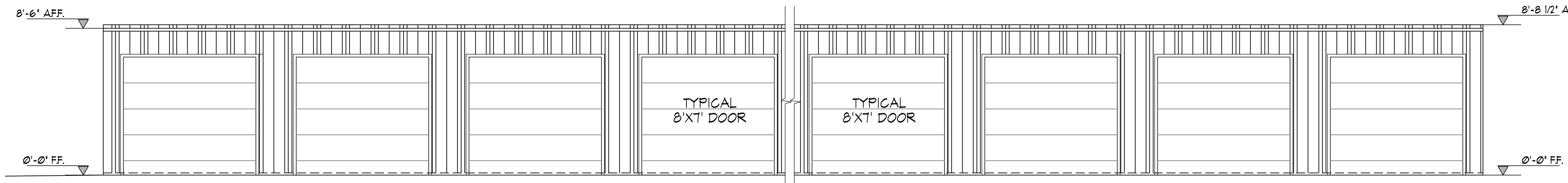

FRONT ELEVATION
(BUILDING A) SCALE: 1/4"=1'-0"

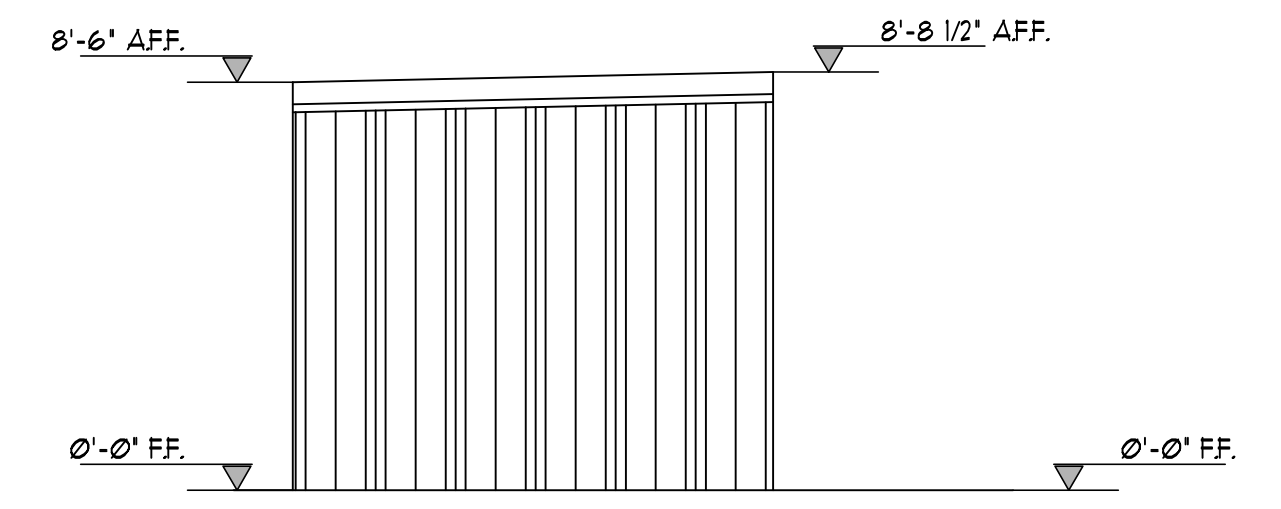

SIDE ELEVATION
(BUILDING - A) SCALE: 1/4"=1'-0"

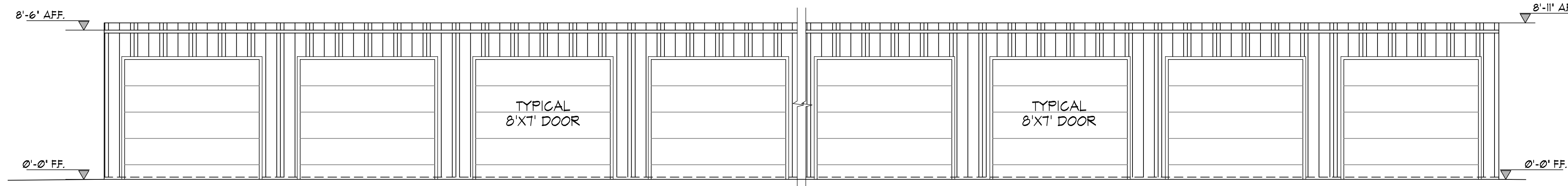

FRONT ELEVATION
(BUILDING B) SCALE: 1/4"=1'-0"

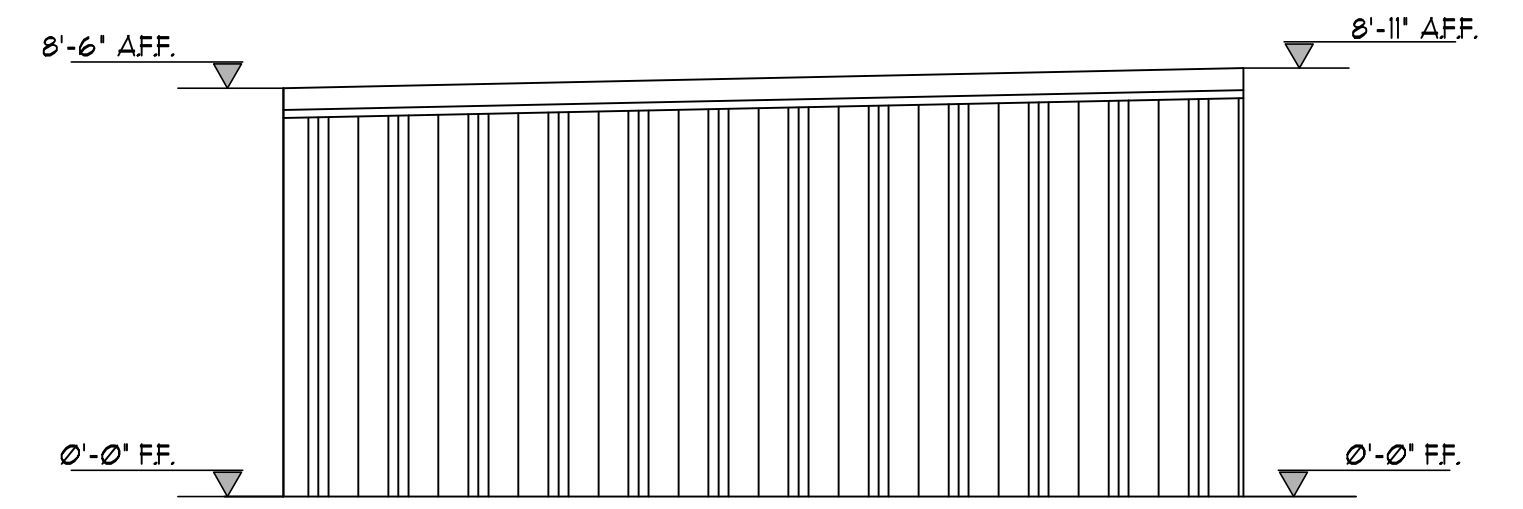

SIDE ELEVATION
(BUILDING - B) SCALE: 1/4"=1'-0"

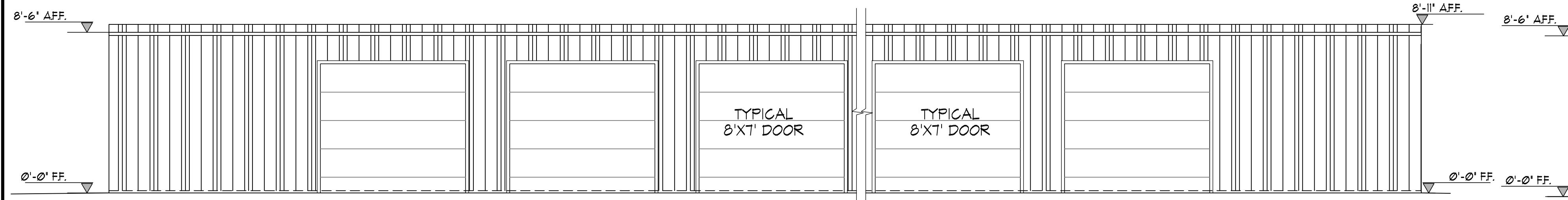

FRONT ELEVATION
(BUILDING C) SCALE: 1/4"=1'-0"

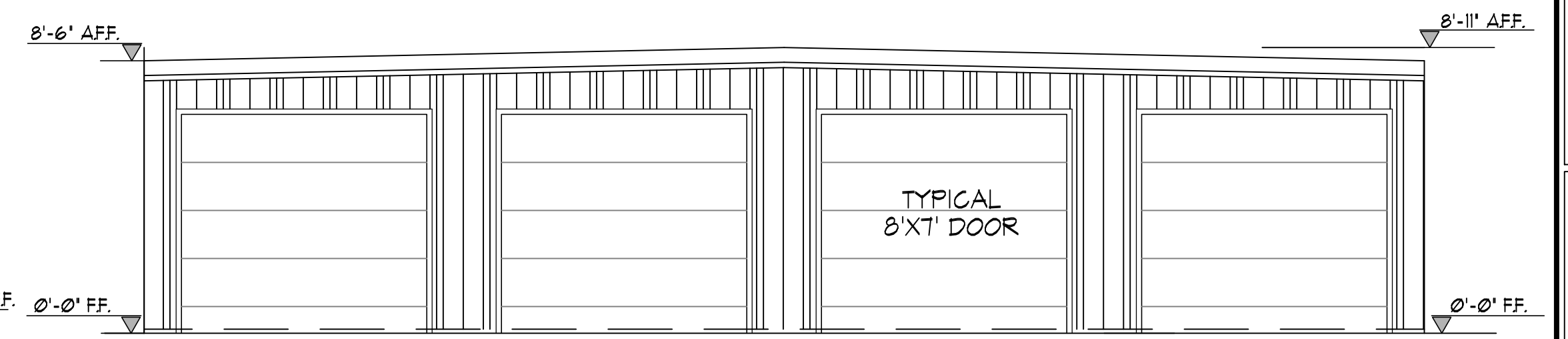

SIDE ELEVATION
(BUILDING - C) SCALE: 1/4"=1'-0"

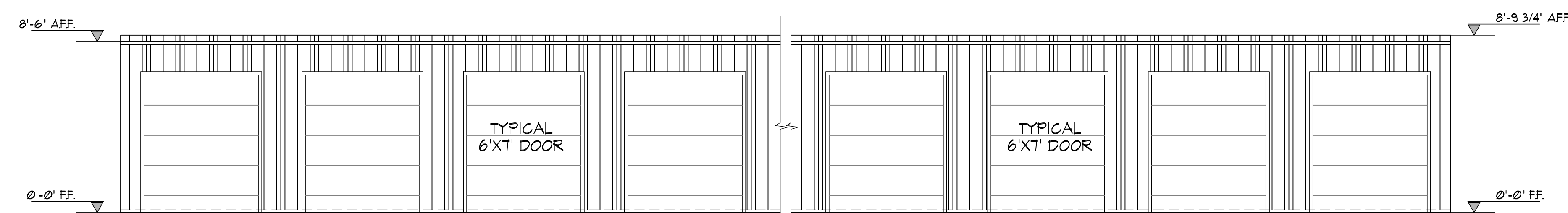

FRONT ELEVATION
(BUILDING D-E) SCALE: 1/4"=1'-0"

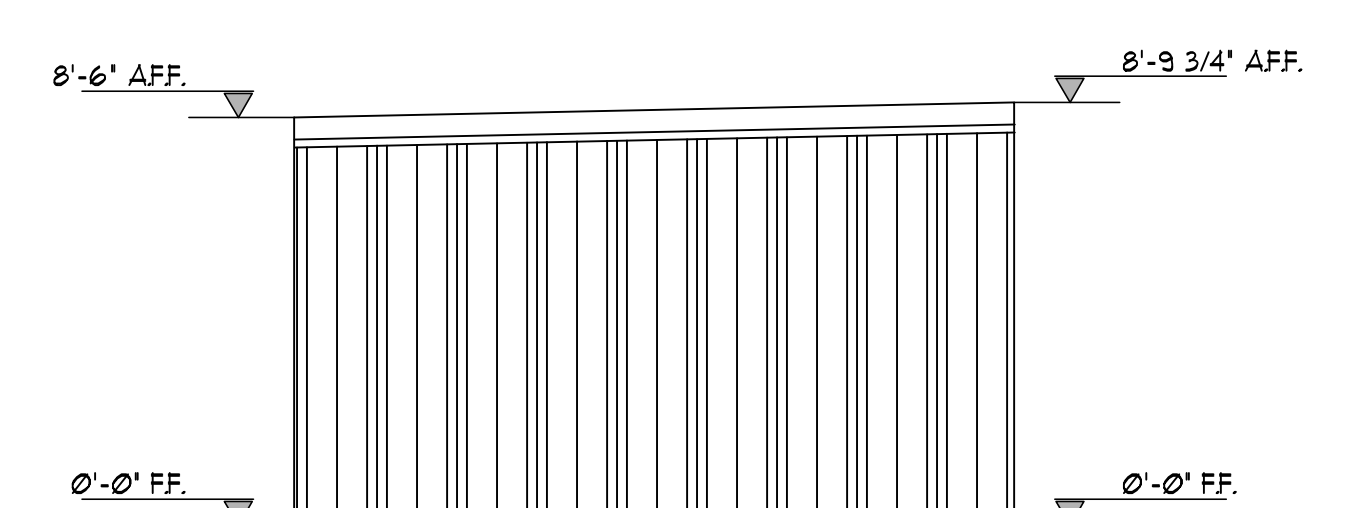

SIDE ELEVATION
(BUILDING D-E) SCALE: 1/4"=1'-0"

REVISIONS	

LOT 37
PLAZA COLIBRI
COMMERCIAL
SUBDIVISION

ELEVATIONS

COLIBRI SELF
STORAGE

EDAIS
Engineering, Inc.
Yuma, Arizona 85395
www.edaisgroup.com
www.edaisengineering.com
na.jeh@edaisgroup.com
(928) 344-3588

DATE:	JANUARY 2024
DRAWN:	LPR
CHECKED:	NKE
PROJECT:	24-005
SHEET NUMBER	

A2

Narrative Statement

We request the City of San Luis to Review and submit the conditional use permit for Lot 37 in Plaza Colibri to the planning and zoning commission and the San Luis city council. This is a storage complex that is going to at lot 37 in Plaza Colibri. The proposed Storage complex is going to be located at intersection of Avenue E and County 24 St, in San Luis AZ 85349



AGENDA ITEM REVIEW FORM

Regular City Council Meeting

7. E.

Meeting Date: 04/10/2024

Department Head: Jose A. Guzman, Director of Development Services, Development Services

Submitted By: Juan Tejeda, Associate Planner, Development Services, Planning & Zoning

Action Requested: Motion

Public Hearing

ITEM:

Public hearing followed by discussion and possible action on any and all matters regarding Conditional Use Permit Case No. 2024-0040 - Rio Colorado Fueling Systems Fuel Station; a request by Core Engineering Group, on behalf of RL Jones Properties LLC, for a Conditional Use Permit from Section 18.40.20 (C)(1) and (10) of the City of San Luis Zoning Ordinance to allow a truck stop with a gas station and convenience store, located on the southwest corner of Vaughan Street and Port Authority Avenue in San Luis, Arizona. **(Jose A. Guzman, Director of Development Services)**

A. Open Public Hearing

1. Presentation by staff and/or applicant
2. Call to the Public on this item

B. Close Public Hearing

C. Action on Conditional Use Permit Case No. 2024-0040

SUMMARY:

The applicant is requesting the development of a truck stop with a fuel station and convenience store in a property zoned Light Industrial (L-I). Section 18.40.20(C)(1) of the City of San Luis Zoning Ordinance allows truck stops within the L-I zoning district with a conditional use permit, and Section 18.40.20(C)(10) allows commercial uses compatible with the purpose of this district.

ANALYSIS:

The subject property is assessor's parcel 227-23-023, located in the Magrino Industrial Park, and all the adjacent properties are zoned L-I.

According to the site plan submitted by the applicant, the project will be developed in two phases. The first phase will be the construction of a commercial fueling station, and the second phase will be the convenience store and six private vehicle pumps. Since the project has the potential to generate a large number of traffic trips per day, staff is recommending a traffic study in accordance with the adopted Public Works Standards. The developer must provide all the necessary improvements required by the traffic study during the construction of any phase of this proposed project.

REVIEW(S):

As part of the review process, all land use cases are reviewed by various city and outside agencies. As required by state statute, staff sent notification letters to property owners within 300 feet of the proposed project (three (3) letters). The city has not received any other significant concerns or objections from the various review agencies or adjacent property owners.

CITIZEN REVIEW MEETING:

As required by state statute and City Code, a Citizen Review meeting was held at City Hall on March 5, 2024, at the City Hall Chambers at 6:00 p.m. The intent of this meeting was to allow the public to learn about the project, ask questions, and express any comments. Nobody from the public was present during the meeting.

PLANNING AND ZONING COMMISSION MEETING:

The Planning and Zoning Commission held a public hearing for this item at their regular meeting on March 12, 2024, at the Council Chambers of the City of San Luis. The commission agrees with the recommendation of staff and forwards this case to the City Council with the recommendation of approval with conditions.

STAFF RECOMMENDATION:

The applicant has provided the information and materials necessary for the review of this Conditional Use Permit request.

Staff recommends approval of Conditional Use Permit Case No. 2024-0040 subject to the following conditions:

1. Development shall comply with the City of San Luis Zoning Regulations, Building Code Requirements, Public Works Standards, and any applicable regulations for industrial development.
2. The applicant/owner shall submit a Trip Generation Memo for the proposed development to determine if the proposed use generates 100 or more trips during the peak hour. If 100 or more trips are generated during the peak hour, the applicant/owner shall submit a traffic study during the building permit review, and all improvements recommended by the traffic study that are caused by the proposed development shall be constructed by the developer to the satisfaction of the Public Works Director.

RECOMMENDATION / SUGGESTED MOTION:

A. I MOVE TO OPEN PUBLIC HEARING

1. Presentation by staff
2. Call to the public on this item

B. I MOVE TO CLOSE THE PUBLIC HEARING

C. I MOVE TO APPROVE CONDITIONAL USE PERMIT CASE NO. 2024-0040 SUBJECT TO THE CONDITIONS OF APPROVAL AS PRESENTED BY STAFF.

Fiscal Impact

IS THERE FISCAL IMPACT ASSOCIATED WITH THIS ITEM:	n/a
CITY/STATE/FEDERAL FUNDS:	n/a
TOTAL:	n/a
BUDGETED AMOUNT:	n/a
AVAILABLE AMOUNT TO TRANSFER:	n/a
ACCT NAME & GL#/REMAINING BALANCE BEFORE PURCHASE:	n/a
FISCAL IMPACT STATEMENT (IF THIS IS A BUDGET TRANSFER, YOU MUST ATTACH THE BUDGET ADJUSTMENT FORM):	n/a

Attachments

Location Map
Site Plan

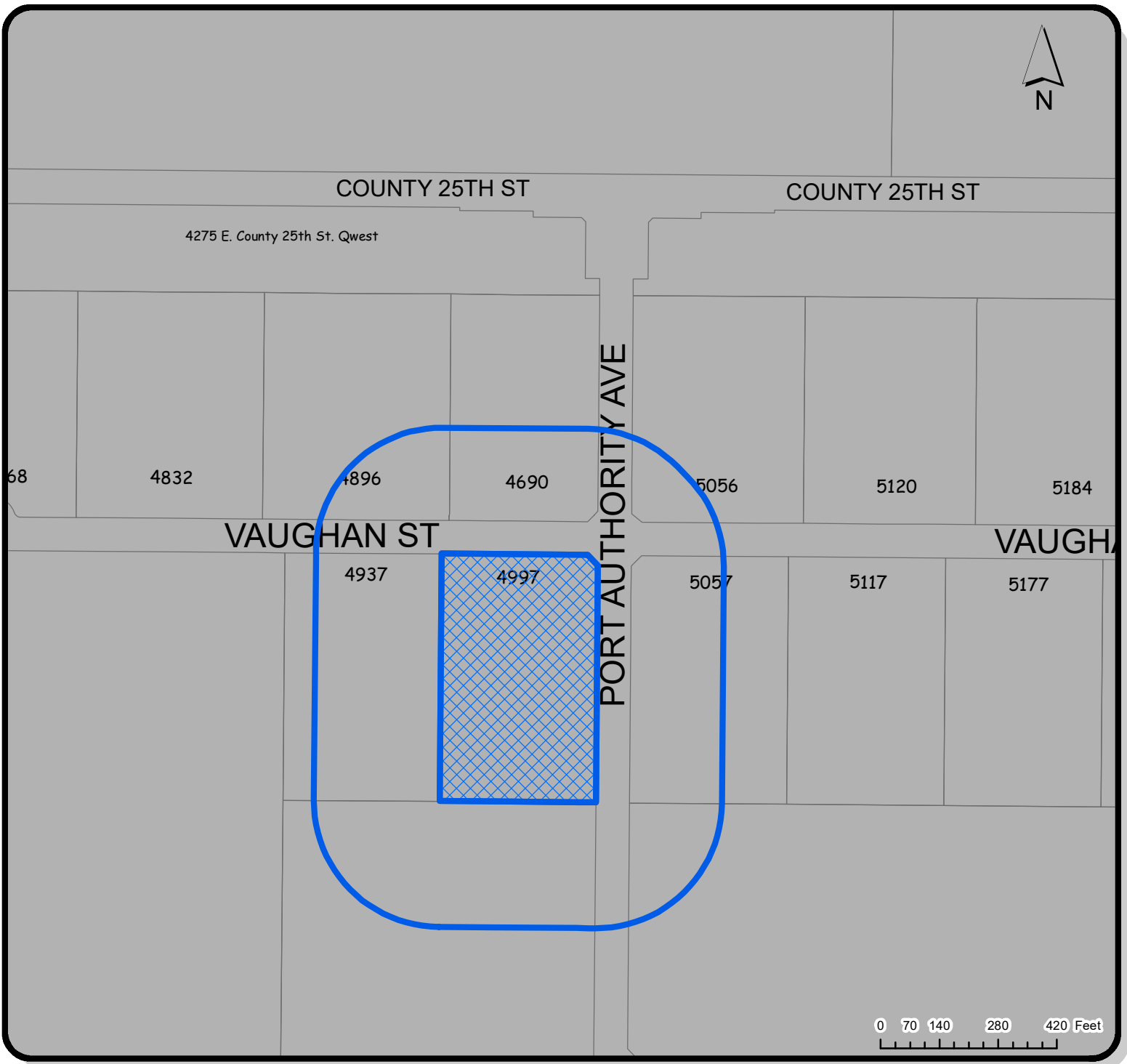

LOCATION OF SUBJECT PROPERTY

LOCATION MAP

CONDITIONAL USE

 PARCEL ID: 22723023
4997 E VAUGHAN ST

Legend
INDUSTRIAL ZONING DISTRICTS
 LI

CASE #
2024-0040

 300ft Notification Area

DATE:
2/6/2024

PLANNING & ZONING



GIS

CREATED BY:
ISAAC GUTIERREZ

CHECKED BY:
JUAN TEJEDA

APPROVED BY:
JOSE A. GUZMAN

Tue, 12 Mar 2024 4:38pm Z:\2021\21-099\Drawings\Drawings\21-099 Base Layout.dwg - Core Engineering Group, PLLC

30' 0' 30' 60'
SCALE: 1" = 30'

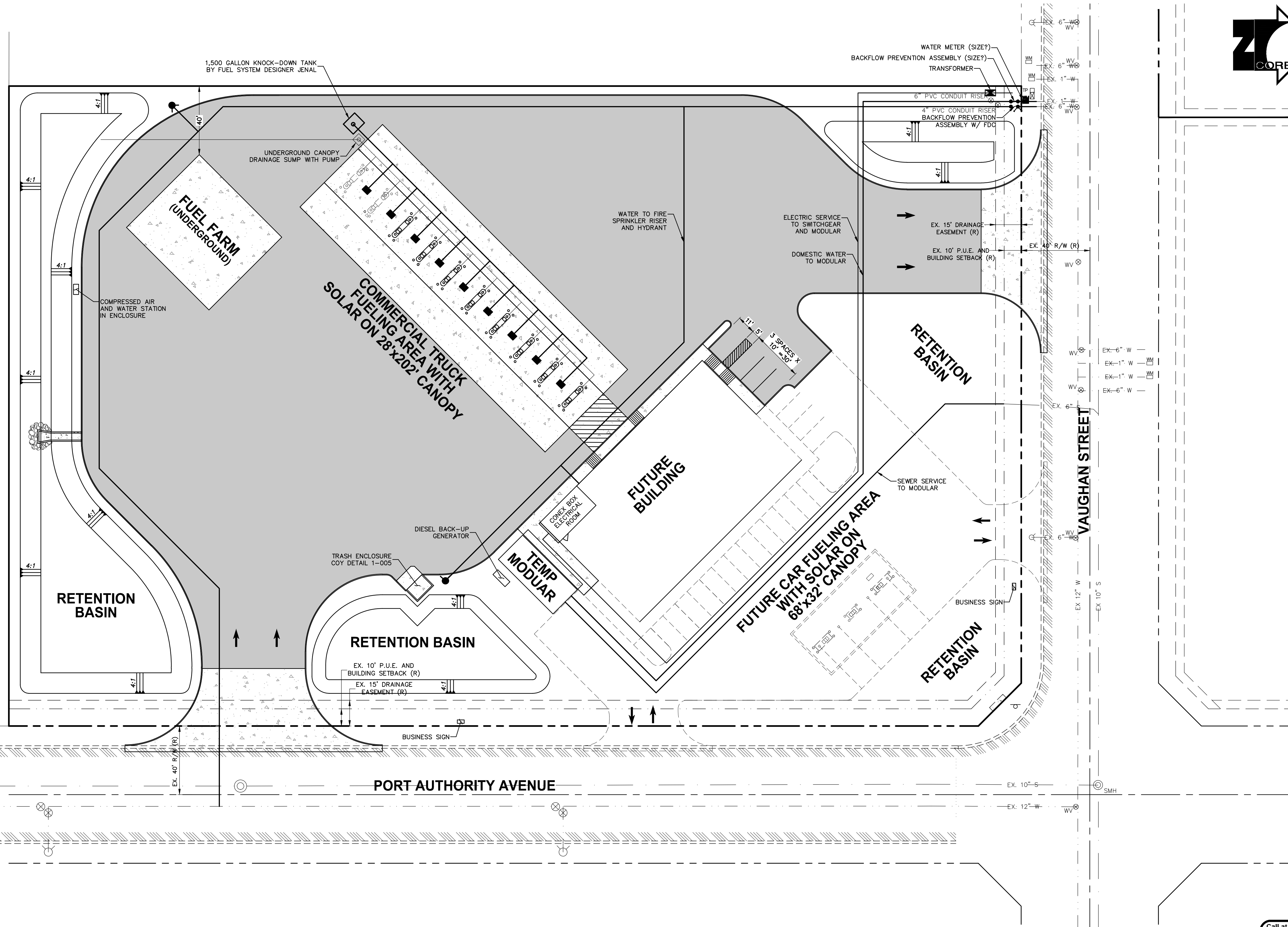
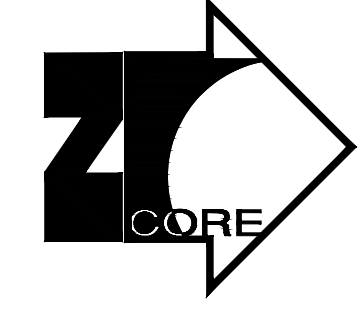

EX-6" W
EX-1" W
EX-1" W
EX-6" W

VAUGHAN STREET

PORT AUTHORITY AVENUE

UTILITY DISCLAIMER

THE UNDERGROUND UTILITIES SHOWN HAVE BEEN LOCATED FROM THE FIELD SURVEY INFORMATION AND EXISTING DRAWINGS. THE SURVEYOR MAKES NO GUARANTEE THAT THE UNDERGROUND UTILITIES SHOWN COMPRISE ALL SUCH UTILITIES IN THE AREA, EITHER IN SERVICE OR ABANDONED. THE SURVEYOR FURTHER DOES NOT WARRANT THAT THE UNDERGROUND UTILITIES SHOWN ARE IN THE EXACT LOCATION INDICATED ALTHOUGH HE DOES CERTIFY THAT THEY ARE LOCATED AS ACCURATELY AS POSSIBLE FROM INFORMATION AVAILABLE. THE SURVEYOR HAS NOT PHYSICALLY LOCATED THE UNDERGROUND UTILITIES.



PRELIMINARY PLAN
NOT FOR CONSTRUCTION

Date: MARCH 2024
Designed: D.J.N.
Drawn: J.R.K.
Checked: J.A.L.
Proj. No.: 21-099

C1.0
SHEET

MAGRINO INDUSTRIAL PARK
APN 227-23-023
CITY OF SAN LUIS
YUMA COUNTY, ARIZONA
PRELIMINARY SITE PLAN

CORE ENGINEERING GROUP, PLLC
200 East 16th Street, Suite 150
Yuma, AZ 85364
V - 928.344.5931 F - 928.344.5932
www.CoreEngineeringGroup.com
Core@core-e-g.com

DRAWING RECORD:

No.	DATE:

THIS DRAWING AND THE DATA CONTAINED HEREON ARE THE PROPERTY OF CORE ENGINEERING GROUP, PLLC AND SHALL NOT BE USED, REPRODUCED OR TRANSMITTED, WITHOUT THE PRIOR EXPRESS CONSENT OF THE COMPANY, NOR SHALL ANY DATA OR INFORMATION CONTAINED HEREON BE USED IN A MANNER INCONSISTENT WITH THE PRIOR EXPRESS WRITTEN AUTHORIZATION OF THE COMPANY.



Core Engineering Group, PLLC

200 E. 16th Street, Suite #150

Yuma, Arizona 85364

voice 928-344-5931

fax 928-344-5932

www.CoreEngineeringGroup.com

Conditional Use Permit Narrative for Rio Colorado Fuel Station

Date: March 12, 2024

To: City of San Luis

From: Douglas J. Nicholls, PE, RLS

The proposed commercial fuel station project is located in Magrino Industrial Park and is designed to serve the growing trucking and employee base projected for the park. The design of the overall industrial park anticipated the development of an internal commercial fueling station to provide convenience for the industry and encourage economic development and investment. This anticipation precludes the need for a traffic study as the roadway network accommodates this traffic; however, Core Engineering Group will comply with the City of San Luis staff proposed conditions to include the production of a trip generation memo.

The facility is located on a Light Industrial (L-I), 5-acre parcel at the southwest corner of Port Authority Avenue and Vaughn Street. It will provide up to nine (9) fuel pumps for diesel tractor trailers in phase one, and up to six (6) pumps for private vehicles along with a convenience store (C-store) in phase two. The C-store will provide restrooms, showers, and consumables. The traffic associated with the different types of pumps will have separate driveways, safely controlling the flow of traffic.

The first phase will include a small site-built permanent structure or Conex structure within the footprint of the planned phase two building to accommodate the fueling infrastructure along with the seven active commercial fueling spaces with space to accommodate two more under the solar topped canopy. In phase one operations will be run from a modular building which will remotely monitor the fueling infrastructure, and contain the public restroom facility. The second phase will include the remainder of the convenience store and the six private vehicle pumps. The convenience store and private vehicle pumps are a commercial use compatible with surrounding Light Industrial district uses, and are a natural commercial endeavor associated with typical truck stop developments nationwide. The timing of construction of the second phase will be dependent upon market demand. As this facility is designed to serve the industrial park and traffic that passes naturally rather than attracting commercial and passenger vehicles that would not be on a natural route, the timing of the development of phase two is dependent on the development of the industrial park; therefore, it is requested that Council amend the typical one year expiration of this Conditional Use Permit to be valid for three years to allow for the development of the industrial park in order for the potential customer base to grow to a point where the convenience store and passenger vehicle fueling might be required in this location.



AGENDA ITEM REVIEW FORM

Regular City Council Meeting

7. F.

Meeting Date: 04/10/2024

Department Head: Jose A. Guzman, Director of Development Services, Development Services

Submitted By: Juan Tejada, Associate Planner, Development Services, Planning & Zoning

Action Requested: Motion

ITEM:

Discussion and possible action on any and all matters regarding Subdivision Case No. 2024-0047F - Bienestar Estates 10 Townhomes; a request by Vega & Vega, on behalf of Comite de Bienestar, Inc., for the approval of the final plat for Bienestar Estates 10 Townhome Subdivision, located at the southeast corner of Avenue F and County 24th Street in San Luis, Arizona. **(Jose A. Guzman, Director of Development Services)**

SUMMARY:

This subdivision will contain approximately 3.47 acres and will consist of 31 residential lots. The residential lots range in size from approximately 2,900 square feet to 3,520 square feet. Assessor's Parcel Number 783-05-162. Access to the subdivision will be through the north side from County 24th Street; access from Avenue F will be reserved for emergency vehicle access only.

Rezoning of said parcel from Community Commercial (C-2) to Medium-High Density Residential (R-2) was approved by the City Council on March 13, 2024, which allows the applicant to increase the residential density with smaller lots for townhomes.

The applicant has provided the information and materials necessary for the review of the final plat for Bienestar Estates 10 Townhome Subdivision.

STAFF RECOMMENDATION:

Staff recommends approval of Subdivision Case No. 2024-0047F with the following conditions:

1. Applicant must address comments from Comment Letter dated 3-8-2024

RECOMMENDATION / SUGGESTED MOTION:

I MOVE TO APPROVE SUBDIVISION CASE NO. 2024-0047F WITH CONDITIONS AS PRESENTED BY STAFF.

Fiscal Impact

IS THERE FISCAL IMPACT ASSOCIATED WITH THIS ITEM:	n/a
CITY/STATE/FEDERAL FUNDS:	n/a
TOTAL:	n/a
BUDGETED AMOUNT:	n/a
AVAILABLE AMOUNT TO TRANSFER:	n/a

ACCT NAME & GL#/REMAINING BALANCE BEFORE PURCHASE: n/a

FISCAL IMPACT STATEMENT (IF THIS IS A BUDGET TRANSFER, YOU MUST ATTACH THE BUDGET ADJUSTMENT FORM):

n/a

Attachments

Location Map

Final Plat

Comment Letter 3-8-24

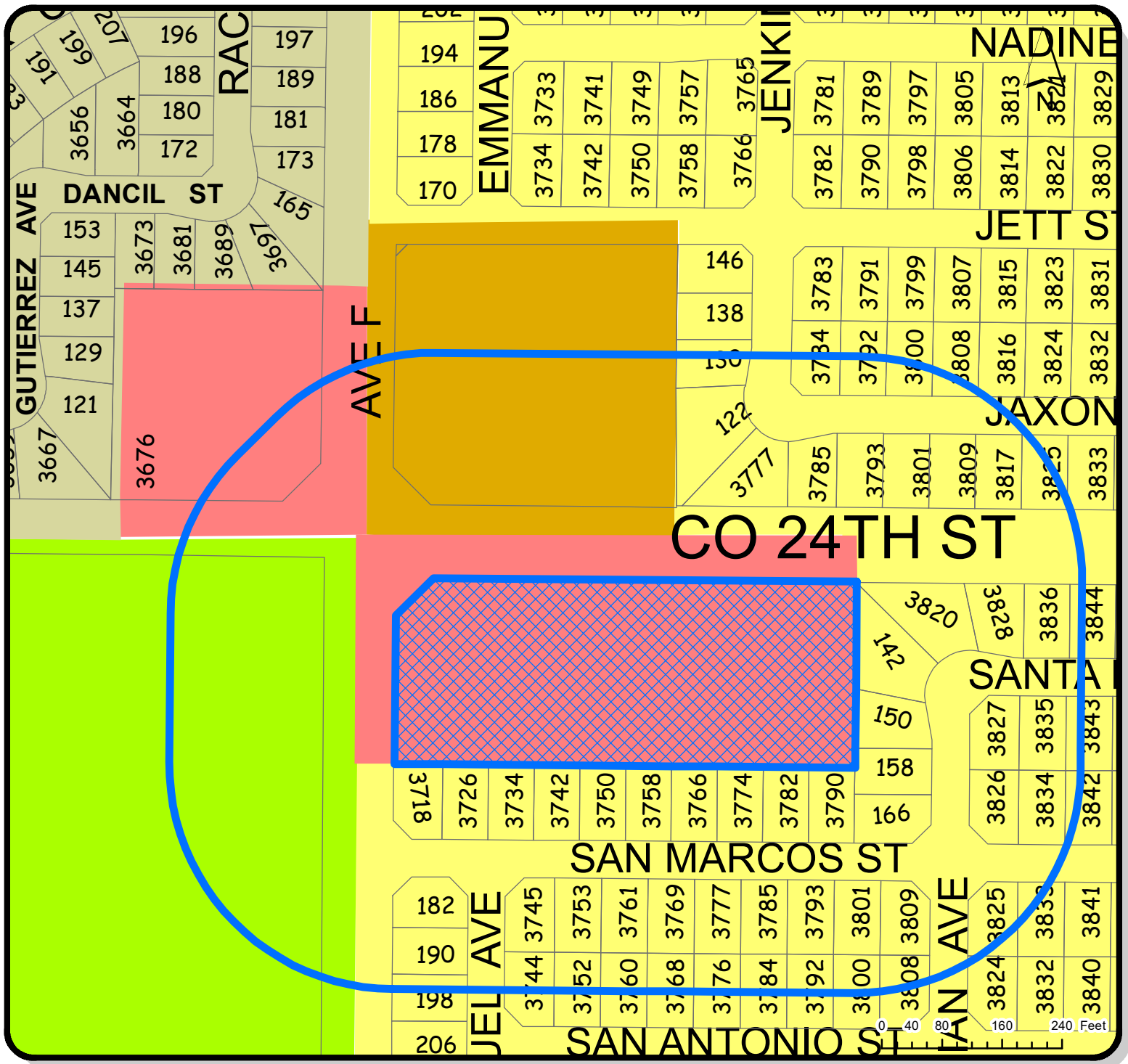

LOCATION OF SUBJECT PROPERTY

 **PARCEL ID: 783-05-162**

 **300ft Notification Area**

LOCATION MAP

- Legend**
- SINGLE RESIDENCE ZONING DISTRICTS**
 - R1-6
 - RA-10
 - MULTIPLE RESIDENCE ZONING DISTRICTS**
 - R-2
 - R-3
 - COMMERCIAL ZONING DISTRICTS**
 - C-2
 - INDUSTRIAL ZONING DISTRICTS**
 - I-1

SUBDIVISION

CASE #
2024-0047F

DATE:
1/12/2024

CHECKED BY:
JUAN TEJEDA

PLANNING & ZONING



GIS

CREATED BY:
ISAAC GUTIERREZ

APPROVED BY:
JOSE A. GUZMAN

BE 10 TOWNHOME SUBDIVISION

A SUBDIVISION OF OF TRACT "B" OF BIENESTAR ESTATES 10 SUBDIVISION, AS RECORDED IN BK. 31, OF PLATS, PG. 22 - 23, YUMA COUNTY RECORDERS OFFICE, YUMA COUNTY, AZ., ALSO BEING A PORTION OF THE NW¹/₄ OF NW¹/₄ OF THE NW¹/₄ OF SECTION 15, T11S, R24W, G.&S.R.B.&M., YUMA COUNTY, ARIZONA. APRIL OF 2024 ACREAGE: 3.47 AC (NET)

FINAL PLAT



SCALE: 1"=30'

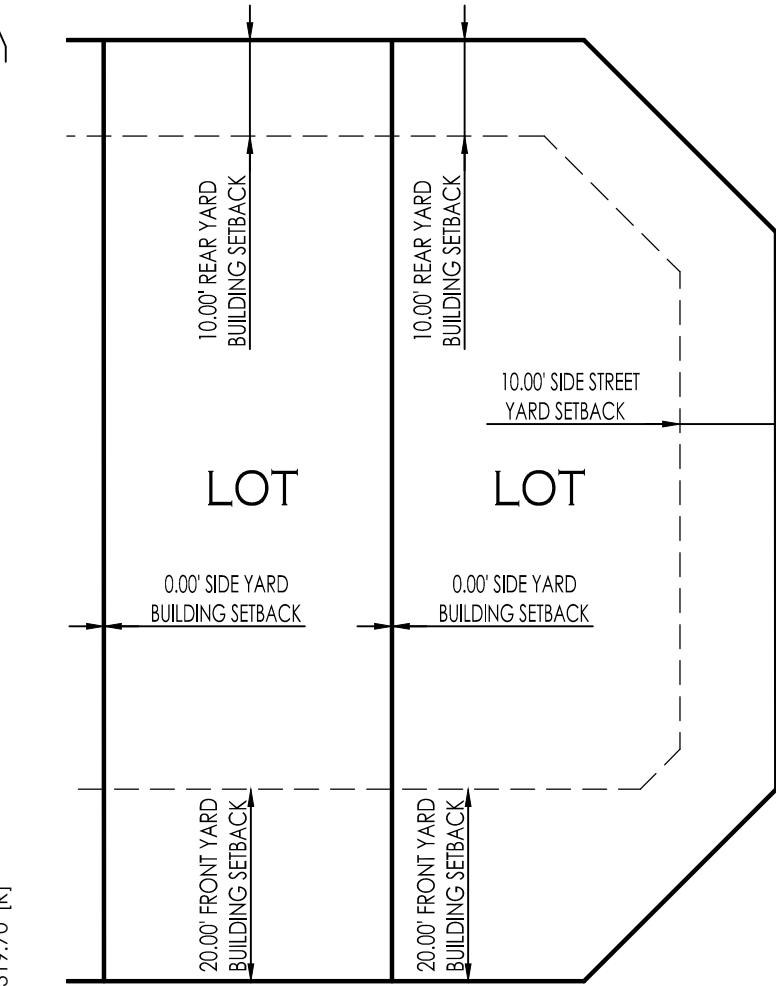
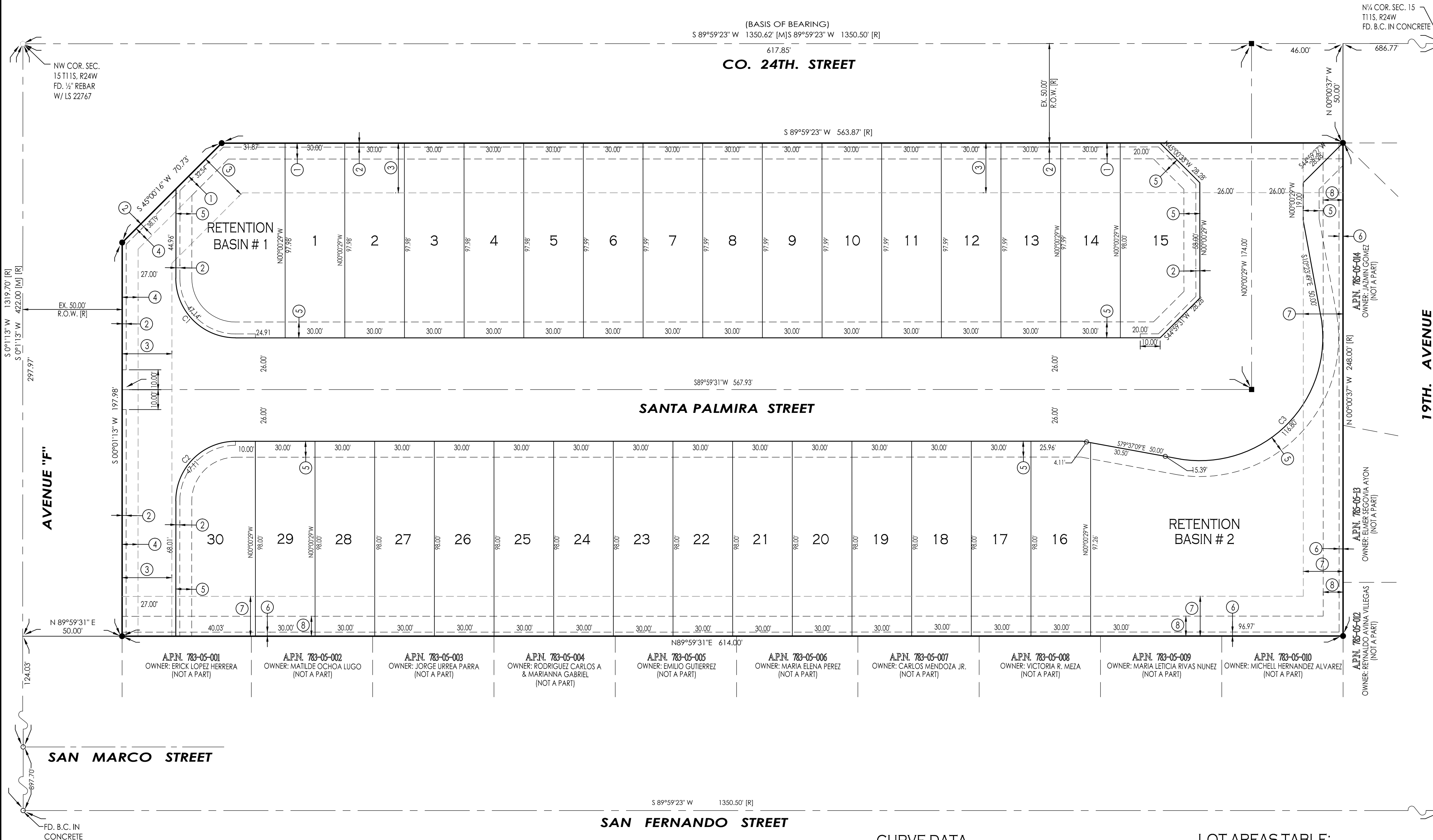

TYP. LOT BUILDING SETBACKS LAYOUT NORTH BLOCK

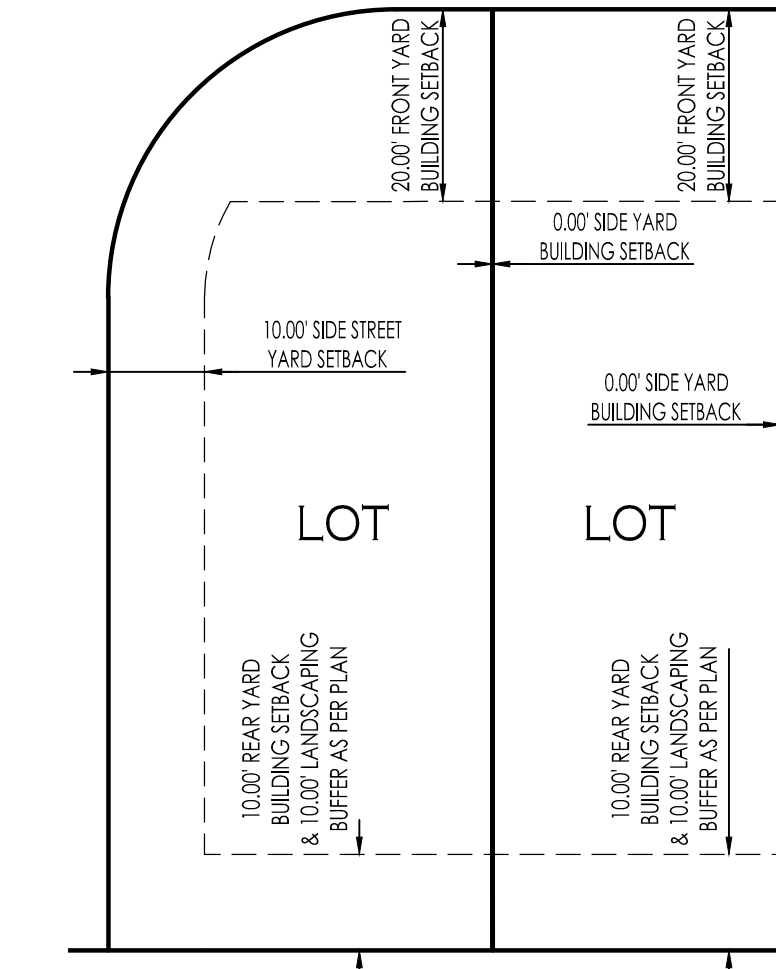

TYP. LOT BUILDING SETBACKS LAYOUT SOUTH BLOCK

LEGEND

- INDICATES BOUNDARY LINE
- - - INDICATES CENTERLINE
- - - INDICATES RIGHT-OF-WAY LINE
- - - INDICATES EASEMENT LINE
- SET PROPERTY CORNER: TO BE MARKED BY 1/2" DIA. REBAR WITH CAP L.S. 16528 (UNLESS OTHERWISE NOTED)
- NEW YUMA COUNTY STD. DETAIL No. 4-080 STREET MONUMENT
- EXISTING MONUMENT (TYPE AS SHOWN)
- INDICATES BRASS CAP
- Y.C.R. INDICATES YUMA COUNTY RECORDERS
- A.P.N. INDICATES ASSESSOR'S PARCEL NUMBER
- (M) INDICATES MEASURED DATA
- (R) DATA REFERS TO BIENESTAR ESTATES 10 SUBDIVISION, AS RECORDED IN BOOK 31 OF PLATS, PAGES 22 & 23, YUMA COUNTY RECORDERS OFFICE, YUMA COUNTY ARIZONA

OWNER OF RECORD:

COMITE DE BIENESTAR INC. AZ CORP.
963 E. 'B' STREET
PO BOX 7170
SAN LUIS, AZ. 85349

BASIS OF BEARING

THE NORTH SECTION LINE OF SECTION 15, T11S, R24W, G.&S.R.B.&M., YUMA COUNTY, ARIZONA (BEING THIS LINE THE CENTERLINE OF Co. 24th STREET), AS SHOWN ON BORDER RANCHES SUBDIVISION, AS RECORDED IN BOOK 27 OF PLATS, PAGES 9 & 10, YUMA COUNTY RECORDERS OFFICE, YUMA COUNTY ARIZONA.

BEARING S89°59'23"W

NOTES:

- * THIS PROJECT IS LOCATED IN FLOOD ZONE "X" AS DETERMINED BY THE FIRM MAPS
- * ZONING: R-2

PREPARED BY:

VrV23-100
VEGA & VEGA
ENGINEERING, PLLC
2619 S. Ave. 2-1/2 E 928-329-0000 Tel
Yuma, Az. 85365 928-247-6232 Fax
www.vegaandvega.com

KEYNOTES

- ① EXISTING 8' UTILITY EASEMENT TO REMAIN
- ② NEW 1' NON-ACCESS EASEMENT
- ③ EXISTING 25' DRAINAGE EASEMENT TO BE ABANDON UPON RECORDATION OF THIS PLAT TO BE REPLACE WITH RETENTION BASINS.
- ④ EXISTING 8' UTILITY EASEMENT TO BE ABANDON UPON RECORDATION OF THIS PLAT TO BE REPLACE WITH NEW LOCATION
- ⑤ NEW 8' UTILITY EASEMENT
- ⑥ EXISTING 1' NON-ACCESS EASEMENT TO REMAIN
- ⑦ EXISTING 20' LANDSCAPING BUFFER EASEMENT TO BE ELIMINATED UPON RECORDATION OF THIS PLAT TO BE REPLACE WITH NEW LOCATION
- ⑧ NEW 10' LANDSCAPING BUFFER EASEMENT TO BE WITHIN THE 10 FT. REAR YARD SETBACK.

LAND SURVEYOR'S CERTIFICATE:

I HEREBY CERTIFY THAT I AM A LAND SURVEYOR LISTED ON THE ROSTER OF ACTIVE REGISTRANTS BY THE STATE BOARD OF TECHNICAL REGISTRATION OF ARIZONA AND THAT THIS MAP CONSISTING OF TWO (2) SHEETS CORRECTLY REPRESENTS A SURVEY MADE UNDER MY SUPERVISION DURING DECEMBER OF 2018 THAT ALL MONUMENTS SHOWN HEREON ACTUALLY EXIST AND THEIR POSITIONS ARE CORRECTLY SHOWN, OR WILL BE IN PLACE WITHIN ONE YEAR FROM RECORDATION OF THIS MAP. THE MONUMENTS WILL BE SUFFICIENT TO ENABLE THE SURVEY TO BE RETRACED. THE SURVEY IS TRUE AND COMPLETE AS SHOWN. ALL DISTANCES ARE SHOWN IN FEET AND DECIMAL PARTS.

BY: *John C. English II*
JOHN C. ENGLISH II R.L.S. No. 16528
ARIZONA, U.S.A.

CURVE DATA

NUMBER	DELTA ANGLE	CHORD DIRECTION	CHORD LENGTH	TANGENT	RADIUS	ARC LENGTH
C1	90°01'42"	S 44°59'38" E	42.44'	30.01'	30.00'	47.14'
C2	89°58'18"	N 45°02'22" E	42.42'	29.99'	30.00'	47.11'
C3	108°17'6"	S 44°59'31" W	100.18'	85.51'	61.80'	116.80'

LOT AREAS TABLE:

LOT #	AREA (SF)	LOT #	AREA (SF)	LOT #	AREA (SF)
1	2939.40 SF.	13	2939.83 SF.	25	2940.00 SF.
2	2939.44 SF.	14	2939.87 SF.	26	2940.00 SF.
3	2939.47 SF.	15	3519.87 SF.	27	2940.00 SF.
4	2939.44 SF.	16	2835.28 SF.	28	2940.00 SF.
5	2939.54 SF.	17	2938.50 SF.	29	2940.00 SF.
6	2939.58 SF.	18	2940.00 SF.	30	2940.00 SF.
7	2939.62 SF.	19	2940.00 SF.	31	3728.00 SF.
8	2939.65 SF.	20	2940.00 SF.	RET #1	4920.75 SF.
9	2939.69 SF.	21	2940.00 SF.	RET #2	11482.99 SF.
10	2939.73 SF.	22	2940.00 SF.		
11	2939.76 SF.	23	2940.00 SF.		
12	2939.80 SF.	24	2940.00 SF.		



City of San Luis

Planning and Zoning Department

Development Services · GIS · Building Safety · Code Enforcement

March 8, 2024

Vianey Vega

Vega & Vega Engineering, P.L.C.

2619 S Ave. 2½ E, Ste #3

Yuma, AZ 85364

Re: Subdivision Case No. 2024-0046P & 2024-0047F BE 10 Townhome Subdivision

City staff has reviewed the 1st Submittal of BE 10 Townhome Subdivision and have the following comments:

City Engineer:

Plat

1. Show "Ex 25' Drainage Easement" as to be abandoned (as it will be replaced by the retention basins.)

Improvement Plans

Paving and Grading Plan

1. Add cross section for 'street' parallel to Avenue F.
2. Provide full drainage report. Note that offsite flow areas should match Reach A and Reach B per the Bienestar 10 Drainage Report (the drainage map shown does not show all of Reach B.)

Water and Sewer Plan

1. Keynotes 10 and 11 should call out ductile iron pipe elbows (not PVC.)

Planning and Zoning Department:

Plat

1. Provide CCR's and Title Report.
2. Please show existing drainage easements as per Fee No. 2019-27117.
3. 8' Utility Easement is an existing easement as per Fee no. 2019-27117.
4. As per Zoning Ordinance Section 18.90.030(B)(3) All "R-2" zoned developments that abut a single residence zoned property shall provide and maintain a landscaped buffer area, a minimum width of ten feet, along the common property line. This landscaped area shall contain a minimum of one tree and two shrubs every 30 feet, or portion thereof, to provide a visual screening between adjacent uses.
5. Please show owners name and assessors number of adjoining parcel (north and west).
6. Extend the north property line to its total of 563.87'.
7. Please show recorded information for [R] and [R3], only [R1] is shown but no used on plat.
8. Please provide building setbacks.

9. Please show Open Space calculations and call out on plan. A 5% of open space is required for R-2 Zoning Districts.
10. Revise APPROVED section " Director of Planning and Zoning" to "Director of Development Services".
11. Increase font size (dimensions and bearing) to be more legible.

Improvement Plans

1. Add reference or location of demolition callouts/enlargements on plan.
2. Call out storm drain pipe for Avenue F runoff.
3. Please provide fire hydrant street markers as per COY Standard.
4. Townhomes will require fire sprinkler system, please provide fire line.
5. Please provide landscaping plans as per Section 18.90 on the City of San Luis Zoning Ordinance.
6. Submit complete Drainage Report.
7. Submit Engineer Design Report for water and sewer facilities.
8. Submit ADEQ permits.

Public Works:

1. Confirm adequate visibility is achieved on driveway onto Co. 24th Street.

Please be advised that the comments made here are tentative in nature. Until all documentation, information, and drawings are submitted and approved in final form, and all permits for construction are approved and issued, the City of San Luis reserves the right to make further comments or require further information or submissions. Any construction which occurs prior to issuance of proper permits is occurring in contravention of the ordinances of the City and is occurring at the risk of the Developer.

If you have any questions on these comments, please contact the Planning and Zoning Department at 928-341-8563 extension 2064.

Thank you,

Juan Tejeda
Associate Planner



AGENDA ITEM REVIEW FORM

Regular City Council Meeting

8. A.

Meeting Date: 04/10/2024

Department Head: Jose A. Guzman, Director of Development Services, Development Services

Submitted By: Juan Tejeda, Associate Planner, Development Services, Planning & Zoning

Action Requested: Board of Adjustment

Motion

Public Hearing

ITEM:

Public hearing followed by discussion and possible action on any and all matters regarding Variance Case No. 2024-0086 - First Days Care; a request by Innov-R, on behalf of GPG Estates and Associates, for a variance from the City of San Luis Zoning Ordinance Section 18.75.040 - Table No. 15 to reduce the parking required from 4 to 2 and a variance from the City of San Luis Zoning Ordinance Section 18.35.040 - Table No. 7 to reduce the minimum setback from 15 feet to 10 feet in a Neighborhood Commercial (C-1), located at 648 N 4th Avenue in San Luis, Arizona. **(Jose A. Guzman, Director of Development Services)**

A. Open Public Hearing

1. Presentation by staff and/or applicant
2. Call to the Public on this item

B. Close Public Hearing

C. Action on Variance Case No. 2024-0086

SUMMARY:

The property in question is located at 648 North 4th Avenue, parcel number 775-46-225, and is zoned as Neighborhood Commercial (C-1). The request is to reduce the parking space required from 4 to 2 from the City of San Luis Ordinance Section 18.75.040 - Table No. 15 and to reduce the minimum front setback from 15 feet to 10 feet from the City of San Luis Ordinance Section 18.35.040 - Table No. 7.

The parcel contains 3,018 sq. ft., while the minimum lot size in commercial zoning districts is 8,000 sq. ft. with a minimum lot width of 60 feet. It is unknown when the property was divided or by which property owner. The property was purchased by the current owner in 2023.

AGENCY REVIEW:

As with all variance requests, this was distributed to various review agencies. We have received comments from the following agencies:

1. City of San Luis Fire Department (3-18-24)

As required by State Statute, staff sent notification letters to property owners within 300 feet of the proposed project (51 letters).

CRITERIA FOR APPROVAL:

All requests for a variance from the City of San Luis Zoning Ordinance must meet the criteria for a variance as set forth in the City of San Luis Zoning Ordinance. A variance is not a right. It may be

granted to an applicant only if the applicant establishes compliance with all of the hardship criteria established in A.R.S. §9-462.06 and is Section 18.15.060 (C) of the Zoning Ordinance. In all cases, the application shall address all the following hardship criteria:

1. There exist special circumstances or conditions regarding the land or building referred to in the application, which do not apply to other properties in the zoning district.
2. The above special circumstances or conditions are preexisting and are not created or self-imposed by the owner or applicant.
3. The variance is necessary for the preservation of substantial property rights. Without a variance, the property cannot be used for purposes otherwise allowed in this zoning district.
4. The authorizing of the variance will not be materially detrimental to persons residing or working in the vicinity, to adjacent property, or to the neighborhood or the public welfare.

The Arizona Revised Statutes (§9-462.069-462.06. Board of adjustment) further state that the Board may not:

1. Make any changes in the uses permitted in any zoning classification or zoning district.
2. Grant a variance if the special circumstances applicable to the property are self-imposed by the property owner.

ANALYSIS:

1. There exist special circumstances or conditions regarding the land or building referred to in the application, which do not apply to other properties in the zoning district. There are no special circumstances or conditions. The conditions creating the request were created by the property owner.

The parcel contains 3,018 sq. ft. when the minimum lot size in commercial zoning districts is 8,000 sq. ft. However, this property is located in the downtown area where many lots have been modified over the years and are smaller in size. However, the circumstances that prompt the request are the result of choices made by the property owner, and they can be addressed by reducing the size of the proposed building.

2. The above special circumstances or conditions are preexisting and are not created or self-imposed by the owner or applicant.

The lot size is preexisting and was not created by the owner or applicant. However, the circumstances that prompt the request are the result of choices made by the property owner, and they can be addressed by reducing the size of the proposed building.

3. The variance is necessary for the preservation of substantial property rights. Without a variance, the property cannot be used for purposes otherwise allowed in this zoning district.

The variance is not necessary for the preservation of substantial property rights. The property is currently used as Neighborhood Commercial (C-1) and the owner can construct any permitted use in this district. However, the dimensions of the proposed project will have to be modified. If the variance is not granted, the property owner retains the ability to use the lot as any permitted use in the district or modify the proposed child care by reducing the building size to meet zoning requirements.

4. The authorizing of the variance will not be materially detrimental to persons residing or working in the vicinity, to adjacent property, or to the neighborhood or the public welfare.

The authorization of the variance will not be materially detrimental to persons residing or working in the vicinity. However, it would potentially increase the issue of off-street parking that currently exists in this neighborhood. There is currently a problem in this area regarding limited off-street parking availability due to existing businesses and agricultural workers parking their cars in this area all day. By allowing less on-site parking, more customers will have to use the limited off-street parking.

STAFF RECOMMENDATION:

Staff has reviewed this request and has determined that it does not meet the required criteria, therefore staff recommends denial of Variance Case No. 2024-0086.

RECOMMENDATION / SUGGESTED MOTION:

A. I MOVE TO OPEN PUBLIC HEARING.

- 1. Presentation by staff and/or applicant
- 2. Call to the Public on this item

B. I MOVE TO CLOSE PUBLIC HEARING.

C. I MOVE TO DENY VARIANCE CASE NO. 2024-0086 BECAUSE THE APPLICATION DOES NOT MEET THE CRITERIA FOR A VARIANCE.

Fiscal Impact

IS THERE FISCAL IMPACT ASSOCIATED WITH THIS ITEM: n/a
CITY/STATE/FEDERAL FUNDS: n/a
TOTAL: n/a
BUDGETED AMOUNT: n/a
AVAILABLE AMOUNT TO TRANSFER: n/a
ACCT NAME & GL#/REMAINING BALANCE BEFORE PURCHASE: n/a
FISCAL IMPACT STATEMENT (IF THIS IS A BUDGET TRANSFER, YOU MUST ATTACH THE BUDGET ADJUSTMENT FORM):
n/a

Attachments

Location Map
Site Plan
Applicants Narrative
Fire Department Comments

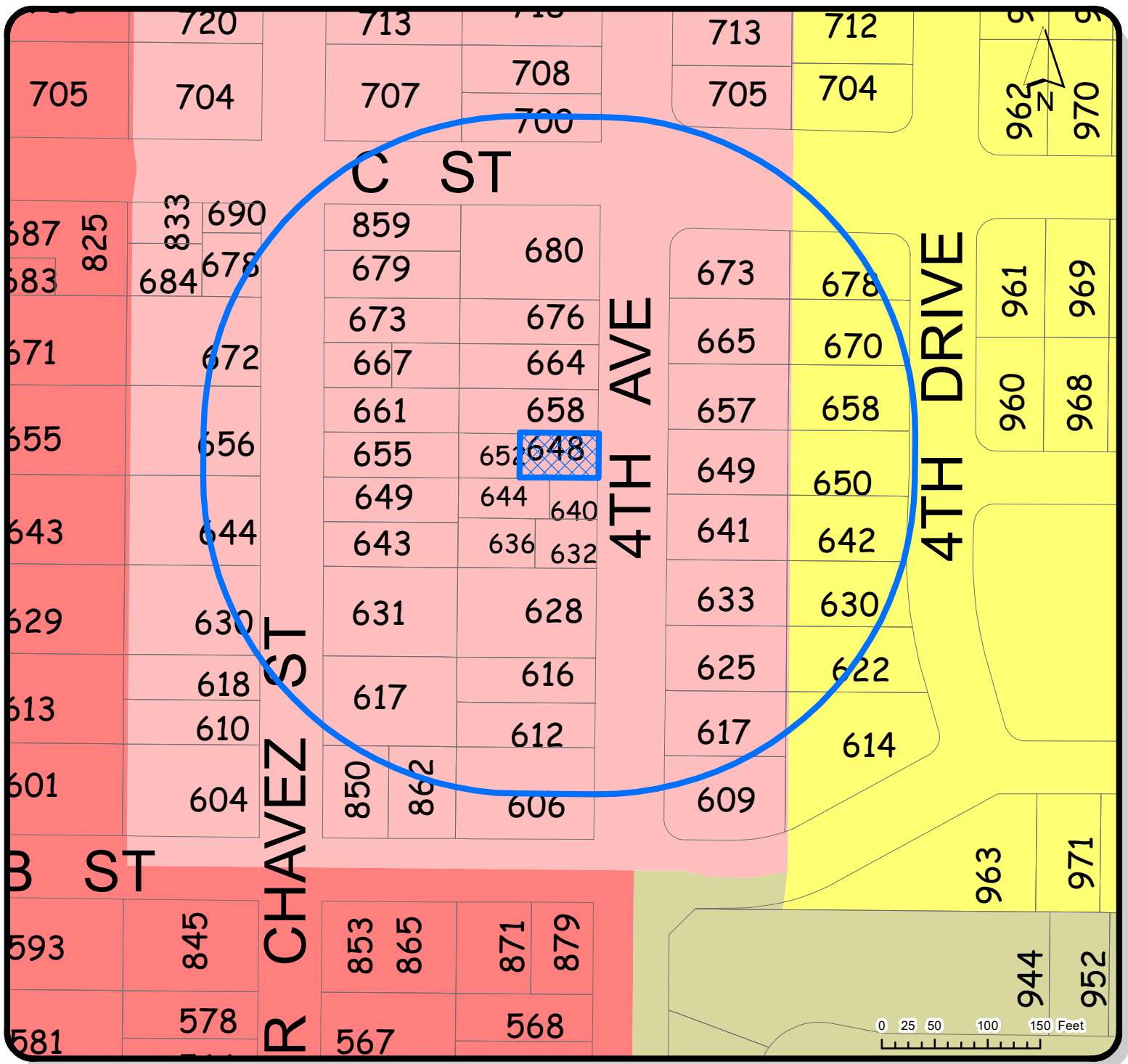

LOCATION OF SUBJECT PROPERTY

LOCATION MAP

VARIANCE

 **PARCEL ID: 775-46-225**
648 N 4TH AVE

 **300ft Notification Area**

Legend
 SINGLE RESIDENCE ZONING DISTRICTS
 R-1-6
 MULTIPLE RESIDENCE ZONING DISTRICTS
 R-2
 COMMERCIAL ZONING DISTRICTS
 C-1
 C-2

CASE #
2024-0086

DATE:
3/12/2024

PLANNING & ZONING



GIS

CREATED BY:
ISAAC GUTIERREZ

CHECKED BY:
JUAN TEJEDA

APPROVED BY:
JOSE A. GUZMAN

PROPERTY LINE: 42.50'

PROPERTY LINE: 71.00'

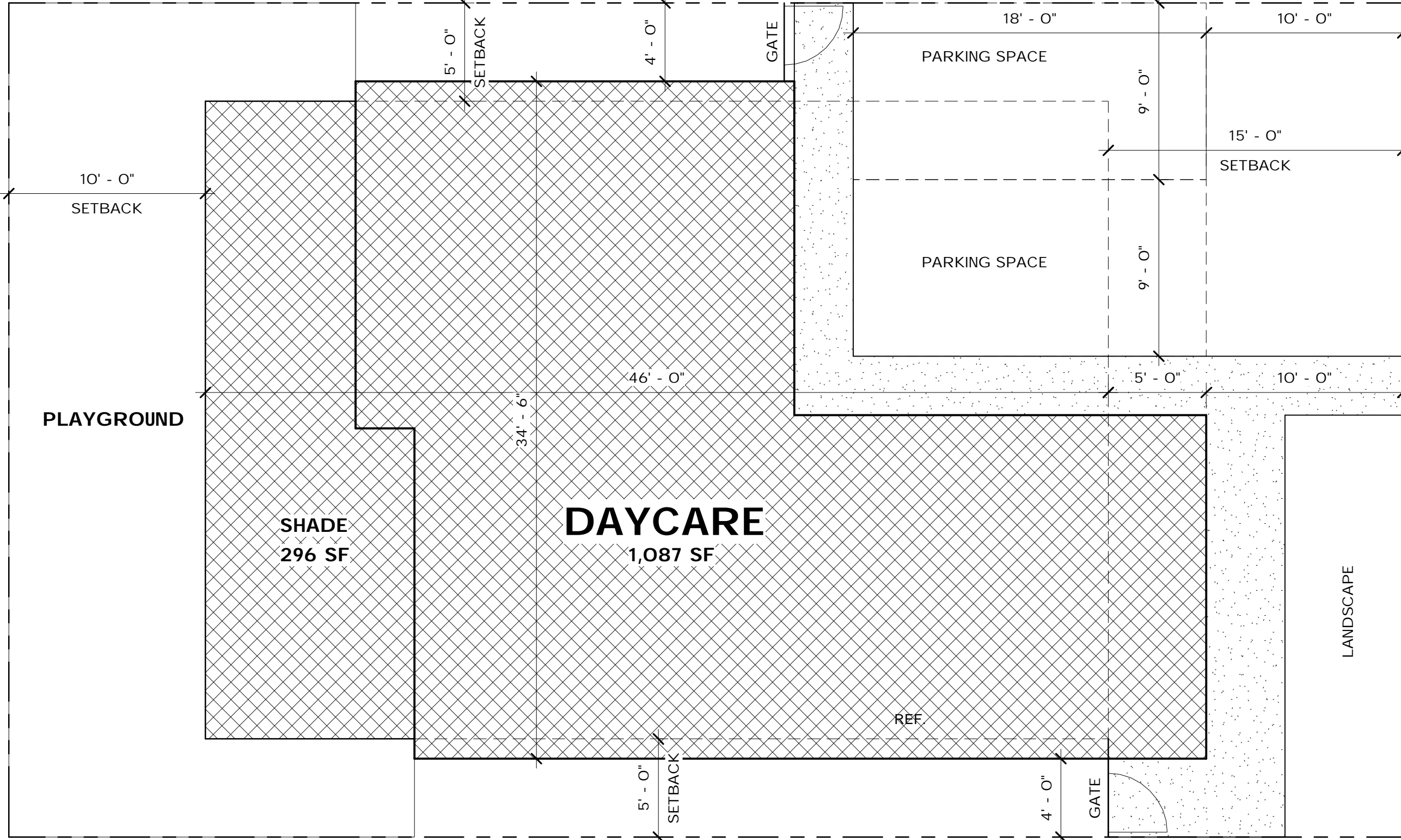

4TH AVENUE

1 Site Plan
 3/16" = 1'-0"

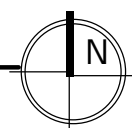

A0

First Steps Daycare
 648 N 4th Ave
 San Luis, AZ 85349
 APN: 775-46-225

JOB NO: 023-0041
 ISSUE DATE: 01/22/24
 Site Plan

INNOV-R
 ARCHITECTURE + ENGINEERING + CONSTRUCTION

928.920.4053
 victor@innov-r-llc.com
 670 E. 32nd St. Suite #11
 Yuma, AZ 85365

PROJECT INFORMATION

JURISDICTION: SAN LUIS ARIZONA

ZONING: C-1

MAX. LOT COVERAGE: 50%

MAX BUILDING HEIGHT: 35'

SETBACKS FRONT= 15'
SIDES= 5'
REAR= 10'
STREET= 10'

LOT AREA: 3,017.05 SF

NOTE: ZERO SETBACK LINES MAY BE APPLIED IF THE FIREWALL REGULATIONS OF THE BUILDING CODE ARE MET.

AREAS

MAX LOT COVERAGE ALLOWED: 1,508.525 SF

DAYCARE: 1,087 SF

SHADE: 296 SF

TOTAL: 1,383 SF < 1,508.525 OK

PARKING REQUIREMENTS

DAYCARE: 1,087 S.F. / 300 S.F. = 3.62 = 4 SPACES

REQUIRED: 4 PARKING SPACES

PROVIDED: 2 PARKING SPACES

A1

First Steps Daycare

648 N 4th Ave
San Luis, AZ 85349
APN: 775-46-225

Parking Count

ISSUE DATE: 02/13/24

JOB NO: 023-0041

INNOV-R
ARCHITECTURE + ENGINEERING + CONSTRUCTION

928.920.4053
Victor@innov-r-llc.com
670 E. 32nd St. Suite #11
Yuma, AZ 85365

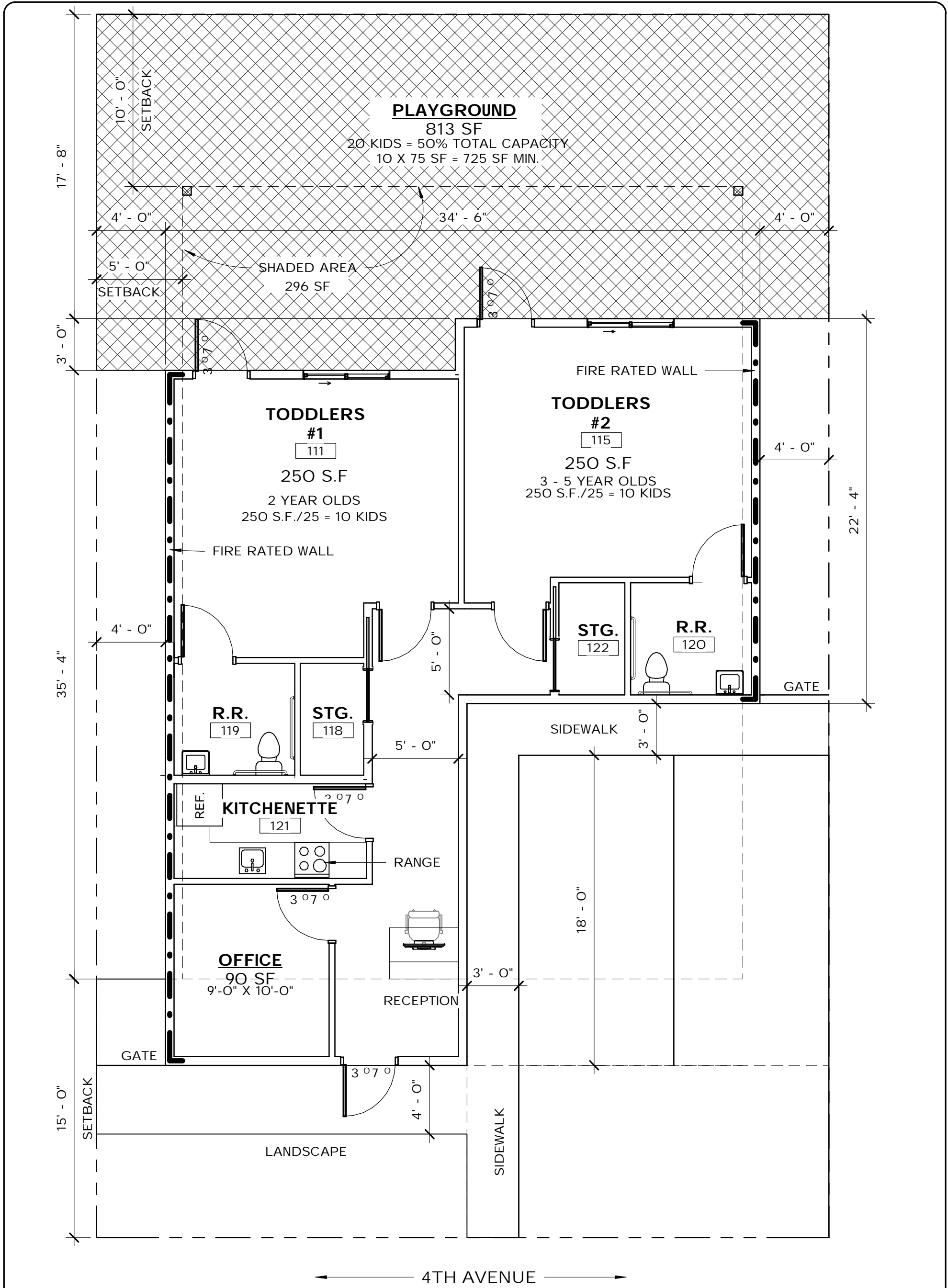

1

Architectural Floor Plan

3/16" = 1'-0"

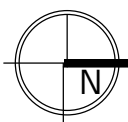

VARIANCE NARRATIVE STATEMENT

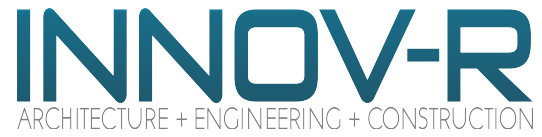

670 E. 32nd. St., Ste #11
Yuma, AZ 85365
www.innov-r-llc.com

Project:

**First Steps Daycare
648 North 4th Ave
San Luis, AZ 85349
APN# 775-46-225**

a) There exists special circumstances or conditions regarding the land or building referred to in the application, which do not apply to other properties in the zoning district.

The whole area was previously designed to host residential use, but was then converted to commercial, not taking into consideration that most properties are not designed to host parking lots and commercial buildings in them due to their dimensions.

This particular plot's size is 42.5 feet wide by 71 feet long, making it very short and narrow compared to most of the nearby commercial properties in the area. The required setbacks per zoning and parking requirements on this particular property limits any possible commercial use.

b) The above special circumstances or conditions are preexisting and are not created or self-imposed by the owner or applicant.

This property was purchased as is, and has not been modified. The whole area was previously designed to host residential use, but was then converted to commercial, not taking into consideration that most properties are not designed to host parking lots and commercial buildings in them due to their dimensions.

c) The variance is necessary for the preservation of substantial property rights. Without a variance the property cannot be used for purposes otherwise allowed in this zoning district.

When it comes to establishing a project involving child care facilities in the State of Arizona, there are a list of design requirements established by the Arizona Administrative Code and Arizona Revised Statutes for Child Care Facilities. Per this code, a minimum of 25 square feet of classroom area needs to be provided per child, and a minimum of 75 square feet of outdoor recreational area for half of the total child occupancy. In order for this project to be financially feasible, a minimum occupancy of 20 children is necessary. Currently the outdoor area for 20 children is 813 square feet and classroom area is 500 square feet, which does not include areas for restrooms, reception area, office and storage.

A zero side setback, as allowed by current Zoning Ordinance, would not be possible due to the need to provide safe egress for the children and staff from rear outdoor recreational area. The minimum

parking requirements per City of San Luis Arizona Zoning Ordinance would take up about half of the permitted buildable area, outside of setbacks, thus making it unfeasible to build anything usable.

d) The authorizing of the variance will not be materially detrimental to persons residing or working in the vicinity, to adjacent property, or to the neighborhood or the public welfare, because a Daycare use is much needed within the city. It would be a benefit for the people within the surrounding residential area and businesses.

The two proposed parking spaces are to be used by staff. Parents would only be dropping off or picking up their children throughout the day, therefore no additional parking is needed.



March 15, 2024

VARIANCE CASE NUMBER: 2024-0086

CASE SUMMARY: A request by Innov-R on behalf of GPG Estates and Associates, for a variance from The City of San Luis Zoning Ordinance Section 18.75.040 Table No.15 to reduce the parking space required from 4 to 2 and a variance from The City of San Luis Zoning Ordinance Section 18.35.040 Table No. 7 to reduce the minimum front setback from 15 feet to 10 feet from in a Neighborhood Commercial District (C-1). The parcel is located at 648 N 4th Avenue in San Luis, Arizona.

PUBLIC HEARING: April 10, 2024

COMMENTS DUE: March 22, 2024

Your comments on this case will help us prepare an accurate and timely staff report. Your comments on this case will be inserted “as is” into the staff report with your name, department, and telephone number, should the applicant have any questions. Your comments are a public record and will be available to the public, media, and the applicant, in addition to the Commission hearing this case. Please complete the section below and return via e-mail. For additional information, please contact Development Services at (928) 341-8563 or at P&Z@sanluisaz.gov.

Thank you,

Juan Tejeda
Associate Planner
Attachments: Location Map and Site Plan

COMMENTS NO COMMENTS

.....
Enter Comments below:

The City of San Luis Fire Department have no comments at this time but reserves the right to comment upon subsequent submittals. Final decisions regarding this request are best made by the Planning and Zoning Department.

Date:

03/18/2024

Agency:

City of San Luis Fire Department

Phone:

928/341-8550

Return to: P&Z@sanluisaz.gov



AGENDA ITEM REVIEW FORM

Regular City Council Meeting

11.

Meeting Date: 04/10/2024

Department Head: Kay Macuil, City Attorney, Attorney's Office

Submitted By: Kay Macuil, City Attorney, Attorney's Office

Action Requested: Motion

ITEM:

Discussion and possible action to hold an Executive Session pursuant to A.R.S. §§ 38-431.03(A)(3), (4), and (7) on any and all matters regarding the lawsuit Gethsemani Food Ministry v. City of San Luis for consultation for legal advice with the city attorneys including but not limited to possible directions including contract negotiations (under subsection (4)) or land lease (under subsection (7)) allowed in executive sessions. **(Kay Marion Macuil, City Attorney, Outside Counsel Cameron Artigue and Manjula Vaz or Gammage and Burnham)**

SUMMARY:

The city's attorneys can properly advise the Council by holding an Executive Session for the purposes described in the agenda item.

RECOMMENDATION / SUGGESTED MOTION:

I MOVE TO HOLD AN EXECUTIVE SESSION PURSUANT TO A.R.S. §§ 38-431.03(A)(3), (4) and (7).

Fiscal Impact

IS THERE FISCAL IMPACT ASSOCIATED WITH THIS ITEM: N/A

CITY/STATE/FEDERAL FUNDS: N/A

TOTAL: N/A

BUDGETED AMOUNT: N/A

AVAILABLE AMOUNT TO TRANSFER: N/A

ACCT NAME & GL#/REMAINING BALANCE BEFORE PURCHASE: N/A

FISCAL IMPACT STATEMENT (IF THIS IS A BUDGET TRANSFER, YOU MUST ATTACH THE BUDGET ADJUSTMENT FORM):

Fiscal impact is not applicable to this agenda item. Under A.R.S. §38-431.03(D), legal action involving a final vote or decision is not permitted to be taken at an executive session.



AGENDA ITEM REVIEW FORM

Regular City Council Meeting

13.

Meeting Date: 04/10/2024

Department Head: Kay Macuil, City Attorney, Attorney's Office

Submitted By: Kay Macuil, City Attorney, Attorney's Office

Action Requested: Motion

ITEM:

DISCUSSION AND POSSIBLE ACTION ITEM:

Discussion and possible action on any and all matters regarding the approval and ratification to engage outside counsel for the lawsuit U.S. District Court for Arizona, Civil Case No. 2:24-cv-00534-ESW. **(City Council and Kay Marion Macuil, City Attorney)**

SUMMARY:

On March 21, 2024, the city received a lawsuit from the law firm of Snell and Wilmer (which has more than 500 attorneys and 16 locations throughout the western United States and an office in Mexico) regarding Gethsemani Baptist Church. This item is to ratify the engagement of Outside Counsel, the firm of Gammage & Burnham, which has attorneys with expertise in federal court litigation and the federal RLUIPA statute (Religious Land Use and Institutionalized Persons Act).

RECOMMENDATION / SUGGESTED MOTION:

I MOVE TO RATIFY AND APPROVE THE ENGAGEMENT AND RETAINER OF GAMMAGE AND BRUNHAM IN THE AMOUNT OF \$50,000.00 UNDER THE TERMS OF THE ATTACHED MARCH 22, 2024, ENGAGEMENT LETTER TO REPRESENT AND DEFEND THE CITY OF SAN LUIS, ITS OFFICIALS AND EMPLOYEES (INCLUDING, WITHOUT LIMITATION, MAYOR NIEVES RIEDEL, ACTING CITY MANAGER JENNY TORRES, AND CODE ENFORCER ALEXIS GOMEZ) IN ANY AND ALL MATTERS IN THE U.S. FEDERAL COURT, ARIZONA, DISTRICT CASE NO. 2:24-CV-00534-ESW .

Fiscal Impact

IS THERE FISCAL IMPACT ASSOCIATED WITH THIS ITEM:

Yes

CITY/STATE/FEDERAL FUNDS:

City

TOTAL:

\$50,000 estimated cost for retainer

BUDGETED AMOUNT:

\$130,000 for all legal contingencies for 2024-2025 Budget Year

AVAILABLE AMOUNT TO TRANSFER:

N/A

ACCT NAME & GL#/REMAINING BALANCE BEFORE PURCHASE: GL 100-12100 & 100-117-80003

FISCAL IMPACT STATEMENT (IF THIS IS A BUDGET TRANSFER, YOU MUST ATTACH THE BUDGET ADJUSTMENT FORM):

Gammage & Burnham have estimated an initial budget of \$50,000. Litigation is unpredictable; therefore, the final costs may be lower or higher. Staff requests that the \$50,000 be paid as a retainer for legal fees within this fiscal year. This initial payment will be allocated to the General Fund Prepaid Services General Ledger account 100-12100. Against this account, subsequent invoices received for services rendered will be posted on the General Ledger expense account 100-117-80003, under Legal Services for the City Attorney department. It is important to note that the final costs associated with these litigation services may vary, potentially being lower than or exceeding the initial retainer fee. Should the litigation extend into the next fiscal year, it could impact next year's budget.

Attachments

Engagement Letter

GAMMAGE & BURNHAM

A PROFESSIONAL LIMITED LIABILITY COMPANY

ATTORNEYS AT LAW

40 NORTH CENTRAL AVENUE

20TH FLOOR

PHOENIX, ARIZONA 85004

TELEPHONE (602) 256-0566
FACSIMILE (602) 256-4475

March 22, 2024

WRITER'S DIRECT LINE
(602) 256-4461
mvaz@gblaw.com

Via Email:(kmacuil@sanluisaz.gov)

Ms. Kay Macuil
San Luis City Attorney

Re: Gammage & Burnham Representation—Gethsemani Baptist Church v City of San Luis

Dear Ms. Macuil:

This letter will confirm that the City of San Luis (“The City”) wishes to employ the law firm of Gammage & Burnham, PLC to assist with a response to the complaint and motion for preliminary injunction filed by the Gethsemani Baptist Church against the City of San Luis, several members of the city staff and the Mayor.

Generally, this Firm bills on an hourly basis; we will bill for our services monthly. Our hourly government rates are as follows:

\$450.00 for partners
\$325-for associates
\$225 for paralegals

My partner, Cameron Artigue and I, will be primarily responsible for such services and representation, although we may delegate matters to other attorneys, and/or paralegals to serve the City’s best interests in the most productive and cost-effective manner. All attorneys and/or paralegals who serve and represent the City shall bill their time on an hourly basis. For this matter, we have agreed to use our discounted government billing rates. The partner billing rate on this matter will be \$450.00.

We will send you a bill on approximately the 15th of the month for work done in the preceding month. Since this is a litigation matter, which can be intensive, we request a retainer of \$50,000.00. We will bill our services against the retainer. We will send you a monthly invoice which shows the work for the month and the payment applied to the retainer.

Although we will perform our professional services on your behalf to the best of our ability, we cannot make (and have not made) any promises regarding the outcome of your matter. You have the right to terminate our services at any time. Similarly, the firm may withdraw from the representation if you fail to promptly pay invoices, fail to disclose material facts, fail to effectively communicate, act in a manner contrary to the advice given, or anything else occurs that, in our opinion, impairs an effective attorney-client relationship.

In addition to attorneys’ fees, we will bill you for costs and expenses such as court costs, long distance telephone calls, photocopying and facsimile transmissions, travel expenses and other expenses incurred in connection with our representation. All of these expenses will be billed to you at our cost with the exception of photocopying and outgoing facsimile transmissions which we do mark up. Other costs such as office supplies, parking and incoming facsimile transmissions will not be billed to you. A copy of the memorandum explaining

firm policy as to billing costs is enclosed. We anticipate that the rates listed in this letter will apply for the duration of this matter. If you ever have any questions concerning our statements, please call me immediately.

Our relationship is covered by the lawyer-client privilege and our ethical duty of confidentiality. Our communications with you are privileged.

Once this representation has been completed, we will close the file and maintain electronic records for five years, at which time the file may be destroyed in accordance with our policies. You must keep us advised regarding any changes of address, email or phone numbers, or of changes regarding key personnel so that we will be able to communicate with you during the course of representation and in the event the need arises even after the file is closed.

We look forward to working with you. If you have any questions, comments or concerns, please do not hesitate to contact me.

Best regards,
GAMMAGE & BURNHAM, PLC

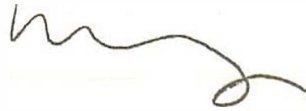

By
Manjula M. Vaz

MMV/bbb
Attachment

ACCEPTED and AGREED:

CITY OF SAN LUIS

By: Kay Marion Macuil
Name: Kay Marion Macuil
Title: City Attorney
March 25, 2025

MEMORANDUM
GAMMAGE & BURNHAM, PLC
A Professional Limited Liability Company

TO: Gammage & Burnham Clients
FROM: Management Committee
RE: Firm Policy as to Billing of Costs

An ethics opinion from The American Bar Association indicates that clients must agree to pay "mark-up" on costs incurred on their behalf. Our practice is to add mark-up to on-site document reproduction costs and outgoing facsimile transmissions. In addition, payments made via credit card will incur a non-refundable service fee, not to exceed 3% of the total amount, which will be added to each transaction.

Other costs are either passed through directly with no mark-up or absorbed in our general overhead – these include:

Costs Charged to Clients Without Mark-Up Costs Not Charged to Clients

- | | |
|---------------------------------|-----------------------|
| ■ computer research | ■ incoming facsimiles |
| ■ depositions | ■ normal postage |
| ■ express mail | ■ office supplies |
| ■ filing fees | ■ parking |
| ■ investigative services | |
| ■ messenger service | |
| ■ outside professional services | |
| ■ publications | |
| ■ recording fees | |
| ■ search fees | |
| ■ secretarial overtime | |
| ■ service of process | |
| ■ sheriff's fees | |
| ■ special postage | |
| ■ title reports | |
| ■ travel expense | |
| ■ witness fees | |

If you have any questions regarding our policy, please feel free to call. If we do not hear from you, we will assume you agree to our policies regarding costs.