

ACREAGE SUMMARY
 EXISTING: 1.4 AC M-1 ZONING, 4.5 AC GB ZONING
 PROPOSED: 4.3 AC M-1 ZONING, 1.6 AC GB ZONING

NOTE:
 NO 100-YR FLOODPLAIN EXISTS ON THE PROPERTY AS DEFINED BY THE COMAL COUNTY, TEXAS COMMUNITY PANEL NUMBER 48091C0485F, AS PREPARED BY THE FEDERAL EMERGENCY MANAGEMENT AGENCY, EFFECTIVE DATE SEPTEMBER 2, 2009.

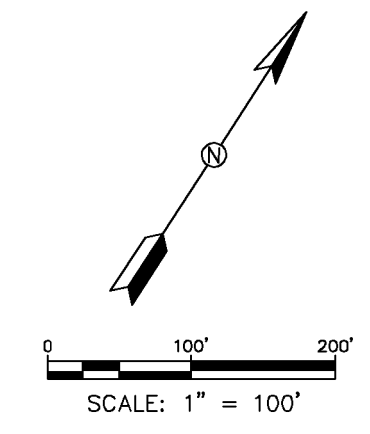

LEGEND

- 200-FT NOTIFICATION BOUNDARY
- M-1 ZONING
- GB ZONING
- PROPERTY #, SEE TABLE FOR ADDITIONAL INFORMATION

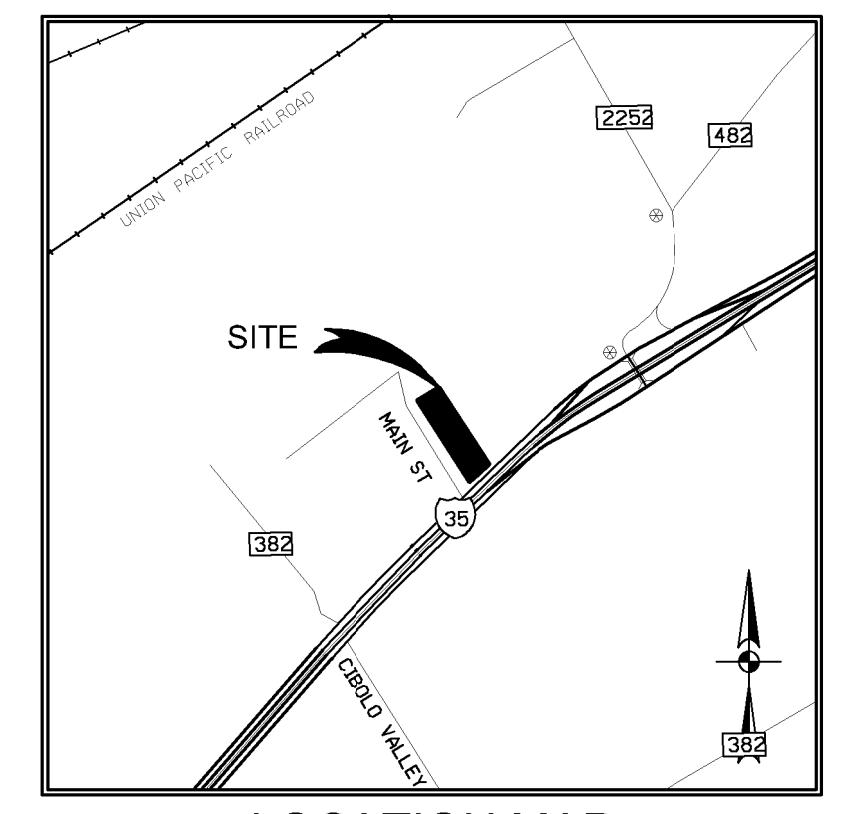

200-FT NOTIFICATION AREA PROPERTY INFORMATION							
PROPERTY #	LAND USE	ZONING	SUBDIVISION NAME	OWNER NAME	PROPERTY ADDRESS	PROPERTY ID#	RECORDING INFORMATION
1	UNDEVELOPED	GB	N/A	EDNA E - ESTATE & ROMAN KRAFT	N IH 35 SCHERTZ, TX 78154	R34178	VOL. 2868 PG. 1009
2	UNDEVELOPED	GB/M-1	N/A	ESTATE OF EDNA KRAFT	18691 IH 35 N SCHERTZ, TX 78154	R78049	DOC. 142-08-144368
3	UNDEVELOPED	M-1	N/A	PAUL DANIELS	IH 35 SCHERTZ, TX 78154	R400975	DOC. 201606037258
4	ACCESS ROAD	GB/MHP	N/A	VIOLA S BUECHE	18711 IH 35 N SCHERTZ, TX 78154	R146387	N/A
5	MOBILE HOME PARK	MHP	N/A	RICHARD & GUADALUPE BARTLETT	18701 IH 35 N SCHERTZ, TX 78154	R78043	DOC. 201406010219
6	STORAGE	GB/M-1	N/A	LOCK AWAY STORAGE SCHERTZ LLC	18913 IH 35 N SCHERTZ, TX 78154	R389410	DOC. 201406042727
7	UNDEVELOPED	GB/M-1	N/A	FRANCES MUEHL	S IH 35 SCHERTZ, TX 78154	R78032	VOL. 356 PG. 729

OWNER/DEVELOPER:
 FEDERICO MARTINEZ
 BEDSTONE LLC
 3736 BEE CAVES RD. #1159
 WEST LAKE HILLS, TX 78746
 512-632-9828

ENGINEER/SURVEYOR:
 MOELLER & ASSOCIATES
 SHANE KLAR, P.E. - ENGINEER
 2021 SH 46W, STE 105.
 NEW BRAUNFELS, TX. 78132
 (830) 358-7127

ACE SURVEYING, INC
 RHONDA K. BUTLER - SURVEYOR
 P.O. BOX 597
 DEVINE, TEXAS 78016
 (830) 334-7264

ZONE CHANGE EXHIBIT

MARTIN & WALKER SURVEY
 113, ABS #414

PREPARED: April 7, 2021

MOELLER & ASSOCIATES
 Engineering Solutions
 2021 SH 46W, Ste. 105
 New Braunfels, TX 78132
 ph: (830) 358-7127
 www.ma-tx.com TBPE FIRM F-13351