

ARTICLE 10. PARKING STANDARDS

Sec. 21.10.1. Purpose.

The purpose of this Article is to establish the number of required off-street vehicular parking spaces so as to provide for the needs of occupants, customers, visitors or others involved in the use or occupancy of any building or structure, to eliminate the undue use of the surface street system for parking purposes, to require allocation of sufficient off-street/on-site loading facilities by business and industry which ensures that the loading and unloading of vehicles will not interfere with traffic flow or block roadways and/or fire lanes, to promote and protect the public health, safety, comfort, convenience and general welfare, and to grant and define the administrative powers and duties necessary to enforce this Article.

Sec. 21.10.2. General provisions.

- A. Required off-street parking in residential districts shall be provided on the same site, lot or tract as the main use for which the parking is provided.
- B. Required off-street parking in nonresidential districts may be located on the same site, lot or tract as the main use for which the parking is provided or on a site, lot or tract located within the same zoning district and within 150 feet of the main use.
- C. If specific requirements for off-street parking result in a fraction of a parking space, the next larger whole number of spaces is required.
- D. Whenever a building or use ~~constructed or established after the effective date of this UDC~~ is changed or enlarged in floor area, number of dwelling units, seating capacity or otherwise, to create a need for an increase in the minimum number of required parking spaces, such spaces shall be provided at 50% of the required rate to accommodate the enlargement or change.
- E. All driveways and all required off-street parking spaces shall be on a paved concrete or asphalt surface. All drive approaches shall be of paved concrete.
- F. Parking spaces provided within a public right-of-way shall not be counted as meeting the minimum requirements of this Article.
- G. In the event of the construction of a phased development, the minimum number of parking spaces provided shall apply to each phase as it is developed.
- H. In computing the parking requirements for any building or development with multiple uses, the total parking requirements shall be the sum of the specific parking requirements for each individual use included in the building or development.
- I. *Residential curb cuts.*
 - 1. *Straight driveways.* Curb cuts for residential driveway aprons shall be not less than ten feet (10') in width, and not more than twelve feet (12') in width for a single driveway apron nor more than twenty-four feet (24') in width for a double driveway apron. Curb cuts will be permitted only for driveway aprons providing access to a garage, carport or hardstand. Not more than one curb cut will be permitted for each residential parcel of land except as follows for circular driveways.

- 2. *Circular driveways.* Circular driveways are allowed for lots with a minimum of one hundred feet (100') of frontage. Circular driveways shall have a maximum of two sixteen-foot curb cuts with a minimum of thirty feet (30') between each cut.
 - J. Detached accessory, ancillary or storage structures in commercial and manufacturing districts shall not be located in a manner that decreases the minimum number of parking spaces required.
 - K. Areas intended for outdoor displays and general outdoor storage shall not be allowed in designated off-street parking areas or fire lanes and shall not be located in a manner that decreases the minimum number of parking spaces required.
 - L. Parking and storage, including vehicles awaiting repair, employee, customers and vendors, for automobile repairs and service located on Main Street, cannot occur in the public right-of-way.
- (Ord. No. 22-S-19 , § 1(Exh. A), 4-26-2022)

Sec. 21.10.3. Size of space.

- A. Each standard off-street surface parking space shall measure not less than ~~nine (9)~~ten feet by ~~eighteen (18)~~20 feet, exclusive of access drives and aisles, and shall be of usable shape and condition.
- B. *Wheel stops.* ~~Wheel stops shall be required for all areas of head-in parking adjacent to a landscaped area required in section 21.9.7. Wheel stops shall be designed so that the overhang of vehicles is contained totally within the parking space.~~ If wheel stops are not provided at locations where vehicles extend over the sidewalk areas, a minimum of five feet (5') of free walking area, exclusive of vehicle over hang, width must be provided.
- C. Each parking space designed for parallel parking shall have a minimum dimension of eight feet by twenty-two feet (8' x 22').
- D. Each standard parking space located in a parking garage shall measure not less than ~~nineteen~~ feet by eighteen feet (~~9~~10' x 18'), exclusive of access drives or aisles.
- E. *Handicap accessible parking.*
 - 1. The number and size of the handicap parking spaces required must follow the Federal Americans with Disabilities Act and Texas Accessibility Standards. The number of handicap parking spaces required is based on the total number of spaces provided. Accessible spaces for cars must have at least a sixty inch (60") wide access aisle located adjacent to the designated parking space. Van parking spaces need to have a wider access aisle of ninety-six inches (96") to accommodate a wheelchair lift and vertical clearance to accommodate van height.

Table 21.10.3 Minimum Number of Handicap Accessible Parking Spaces	
Total number of parking spaces provided (per lot)	Total minimum number of accessible parking spaces
1 to 25	1
26 to 50	2
51 to 75	3
76 to 100	4
101 to 150	5
151 to 200	6
201 to 300	7
301 to 400	8
401 to 500	9

501 to 1,000	2% of total parking provided in lot
1,001 and over	20 plus 1 for each 100 over 1,000

2. *Location.*

- a. Accessible parking spaces must be located on the shortest accessible route of travel to an accessible facility entrance. Where buildings have multiple accessible entrances with adjacent parking, the accessible parking spaces must be dispersed and located closest to the accessible entrances and at the most level ground close to the accessible entrance.
 - b. An accessible route must always be provided from the accessible parking to the accessible entrance. An accessible route never has curbs or stairs, must be at least three feet (3') wide, and has a firm, stable, slip-resistant surface. The slope along the accessible route should not be greater than 1:12 in the direction of travel.
 - c. Accessible parking spaces may be clustered in one or more lots if equivalent or greater accessibility is provided in terms of distance from the accessible entrance, parking fees, and convenience. Van-accessible parking spaces located in parking garages may be clustered on one floor (to accommodate the ninety-eight inch (98") minimum vertical height requirement).
3. *Signage.* A sign with the international symbol of accessibility must be mounted in accordance with applicable state and federal laws to see marking each disabled parking space. Van accessible spaces must have a sign with "van accessible" on it in addition to the international symbol of accessibility.

Sec. 21.10.4. Schedule of off-street parking requirements.

- A. Off-street parking shall be provided in sufficient quantities to provide the following ratio of vehicle spaces for the uses specified in the districts designated:

Table 21.10.4 Schedule of Off-Street Parking Requirements	
Use Type	Parking Requirement
Amusement, Commercial (Indoor)	1 space for each 200 square feet of gross floor area
Amusement, Commercial (Outdoor)	1 space per 500 square feet of outdoor site area plus 1 space per each 4 fixed spectator seats
Assisted Care, Living Facility, Care Facility	1 parking space for each 2 beds
Bank, Savings And Loan, Or Other Financial Institution	1 space for each 250 square feet of gross floor area
Bar Or Night Club	1 space for each 50 square feet of gross floor area
Bed And Breakfast	1 space for each guest room plus 1 space per employee
Bowling Alley	5 parking spaces for each lane
Car Wash	1 space for each 200 Square feet of floor area
Day Care Center	1 space per 250 square feet of gross floor area
Fitness Center/Gym	1 space for each 250 square feet of gross floor area
Convenience Store/Gas Station	1 space for each 250 square feet of gross floor area. Spaces provided for fueling at the pump stations shall not be considered parking spaces.
Group Home	4 spaces
Hospital	1 parking space for each bed
Hotel Or Motel	1 space for each sleeping room or suite plus 1 space for every 200 square feet of common area not designated as sleeping rooms

Lodging Houses And Boarding Houses	1 parking space for each bedroom
Manufacturing, Processing Or Repairing	1 space for each 2 employees or 1 space for each 1,000 square feet of total floor area, whichever is greater
Medical Or Dental Clinic	1 space for each 200 square feet of total floor area
Mini-warehouse/Public Storage	1 space for each 300 square feet of office floor area plus 1 space for each 3,000 square feet of storage area
Mortuary/Funeral Home	1 parking space for each 50 square feet of floor space in service rooms or 1 space for each 3 seats, whichever is less based on maximum design capacity)
Multifamily, Duplex, Two-Family, Condominium Or Other Similar Use	1.57 spaces per 1 bedroom unit 2 spaces per 2 bedroom unit 2.5 spaces per 3+ bedroom unit Plus additional guest parking provided at a ratio of 5% of required spaces
Nursery	1 space per 300 square feet of total sales area Wholesale nursery: 1 parking space per employee of the largest work shift, plus 1 space per 10,000 square feet of display area and 1 space per acre of growing areas
Offices	1 space for each 250 square feet of gross floor area
Outdoor Facilities (Outdoor Recreational Fields i.e. Football, Soccer, etc.)	20 spaces per designated field or 1 per 4 person design capacity
Public Use	Parking shall be provided at a ratio approved by City staff based on a parking study provided by the applicant
Residence Halls, Fraternity Buildings And Sorority Buildings	1 space per person capacity of permanent sleeping facilities
Residential Subdivision Mailbox Kiosk	2 spaces—these may be in the right-of-way but not in the traffic lane—an expansion of the road surface is required and the kiosk must be covered to provide shelter for people using the kiosk
Restaurants	1 parking space for each 100 square feet of gross floor area, or 1 space for each 4 seats, whichever is less (based on maximum design capacity)
Retail Sales And Service	1 space for each 250 square feet of gross floor area
School, High School, Vocational, All Other Schools	Parking shall be provided at a ratio approved by City staff based on a parking study provided by the applicant that shall include vehicle stacking requirements
Single Family Attached And Detached Dwelling Units	2 parking spaces per dwelling unit
Theaters, Auditoriums, Churches, Assembly Halls, Sports Arenas, Stadiums, Conference Center, Convention Center, Dance Hall, Exhibition Halls, Or Other Place Of Public Assembly	1 space for each 4 seats or 1 space for every 100 square feet of gross floor area, whichever is less (based on maximum design capacity)
Automobile Sales Or Rental	1 space for each 3,000 square feet of sales area (open and enclosed) devoted to the sale, display or rental of vehicles
Automobile Service, Repair, Garage	1 space for each 200 square feet of total floor area

Warehouse	1 space for each 1,000 square feet of total floor area
-----------	--

B. *New and Unlisted Uses.* When a proposed land use is not classified in this section or a single use which have varying parking needs depending on the function of that specific single use, an applicant may submit a parking ratio based on best/current planning and transportation practices.

1. A best/current parking ratio application should include the following:

- a. An application shall fully cite the sources used to derive the applicant-submitted parking ratio, possible resources include parking standards material from the Institute of Transportation Engineers (ITE) or the American Planning Association (APA).
- b. The City Manager or his/her designee shall review the applicant submitted parking ratio to confirm best/current planning practices for a use.
- c. The City Manager or his/her designee shall approve, modify, or deny the applicant submitted parking ratio.

2. Parking ratio determination where no application is submitted

- a. If the applicant does not submit a parking ratio, then the City Manager or his/her designee shall determine the parking ratio based on the best/current planning and transportation practices.

C. *Mixed uses.* In the event that several users occupy a single structure, or parcels of land, the total requirements for off street parking shall be the sum of the requirements for the several uses computed separately unless it can be shown that the peak parking demands are offset, for example with retail and residential, or theater and office uses. In such case the City Manager or his/her designee may reduce the total requirements accordingly, but not more than twenty-five percent (25%).

D. *Joint use of facilities.* Required parking facilities of two (2) or more uses, structures, or parcels of land may be satisfied by the same parking facility used jointly, to the extent that it can be shown by the owners or operators that the need for the facilities does not materially overlap and provided that such right of joint use is evidenced by a deed, lease, contract, or similar written instrument establishing the joint use.

E. *Properties zoned main street mixed-use.* Properties zoned Main Street Mixed-Use shall only be required to provide two (2) on-site parking spaces but must still provide the minimum required number of handicapped spaces on site.

(Ord. No. 14-S-47 , § 5, 11-18-2014; Ord. No. 16-S-27 , § 7, 8-30-2016; Ord. No. 18-S-03 , § 1(Exh. A), 1-23-2018; Ord. No. 22-S-19 , § 1(Exh. A), 4-26-2022)

Sec. 21.10.5. Striping.

- A. All parking lots shall be striped in a manner that will clearly delineate parking spaces, fire lanes and pedestrian crosswalks.
- B. Directional arrows shall be provided in all drive lanes and driveways.

Sec. 21.10.6. Shared access and cross lot access easements.

Notwithstanding any other provisions of this UDC, unless otherwise approved by the City, to reduce the number of curb cuts and access driveways, the dedication of joint-use, private access driveway easements and cross lot access easements shall be required for all commercial development.

Sec. 21.10.7. Stacking requirement for drive-through facilities.

- A. A stacking space shall be an area on a site measuring eight feet by twenty feet (8' x 20') with direct forward access to a service window or station of a drive-through facility which does not constitute space for any other circulation driveway, parking space, or maneuvering area.
- B. All stacking spaces shall be located entirely within the lot and shall be outside of any right-of-way, fire lane or similar access.
- C. For financial institutions with drive-through facilities, each teller window or station, human or mechanical, shall be provided with a minimum of ~~three (3)~~ **five** stacking spaces.
- D. For each service window of a drive-through restaurant, a minimum of seven stacking spaces shall be provided.
- E. For kiosks, a minimum of three (3) stacking spaces for each service window shall be provided.

Sec. 21.10.8. Off-Street loading/unloading requirements.

All retail, commercial, industrial and service structures shall provide and maintain off-street facilities for receiving and loading merchandise, supplies and materials within a building or on the lot or tract. All public schools shall provide adequate stacking for vehicles based on a parking study approved by City Staff. Such off-street loading space may be adjacent to a public alley or private service drive or may consist of a truck berth within the structure. Such off-street loading space or truck berth shall consist of a minimum area of ten feet (10') by forty feet (40') and the spaces or berths shall be provided in accordance with the following schedule:

Square Feet of Gross Floor Area in Structure	Minimum Required Spaces or Berths
0—5,000	None
5,000—15,000	1
15,000—50,000	2
50,000—100,000	3
100,000—150,000	4
Each Additional 50,000 over 150,000	1

(Ord. No. 16-S-27 , § 8, 8-30-2016)

Sec. 21.10.9. Additional regulations and illustrations.

- A. *Handicapped ramps.*

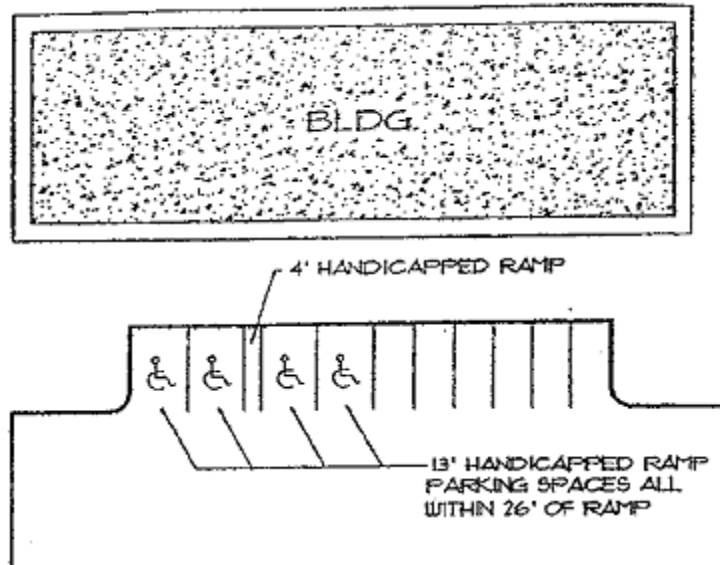

HANDICAPPED RAMP:
within 26' of Parking Spaces

The location of handicapped parking spaces should be:
 1. as close as possible to principal handicapped accessible entrance(s)
 2. Dispersed in a multi-building development or shopping center to ensure easy access and to minimize the travel distance for the handicapped.

B. *Handicapped parking space dispersal.*

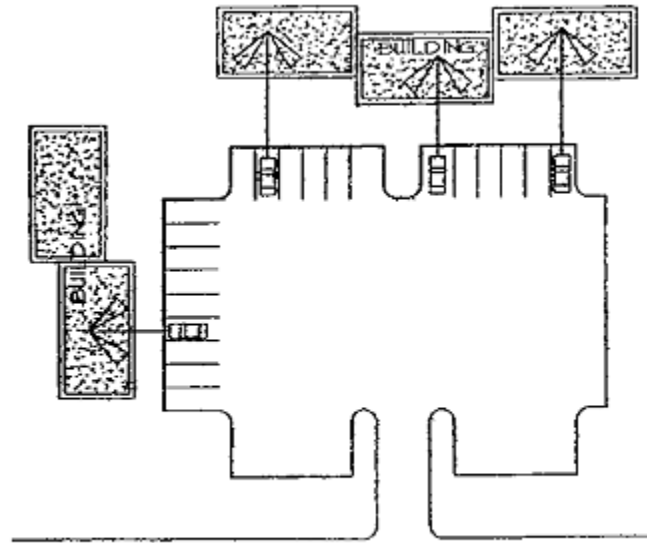

HANDICAPPED PARKING SPACE DISPERSAL

C. *90° parking dimensions.*

90° PARKING DIMENSIONS

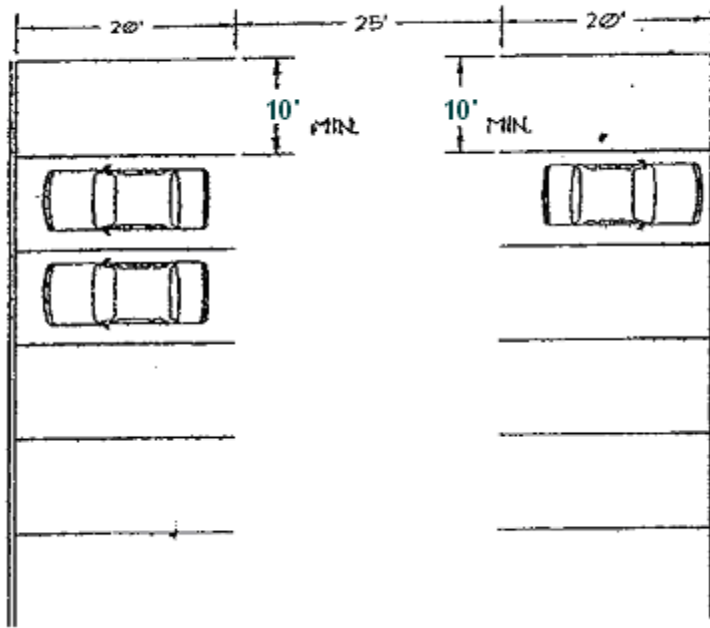

D. *Angle parking dimensions.*

ANGLE PARKING DIMENSIONS

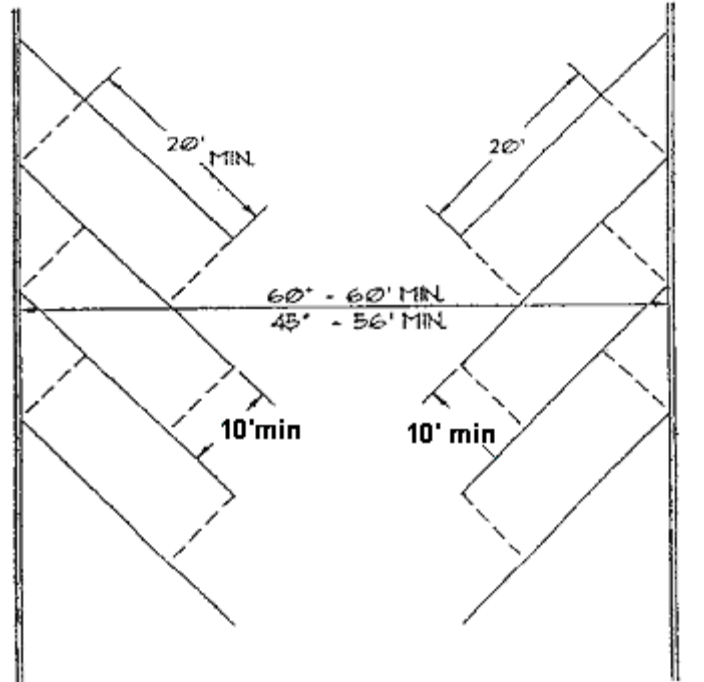

E. *Drive aisle dimensions.*

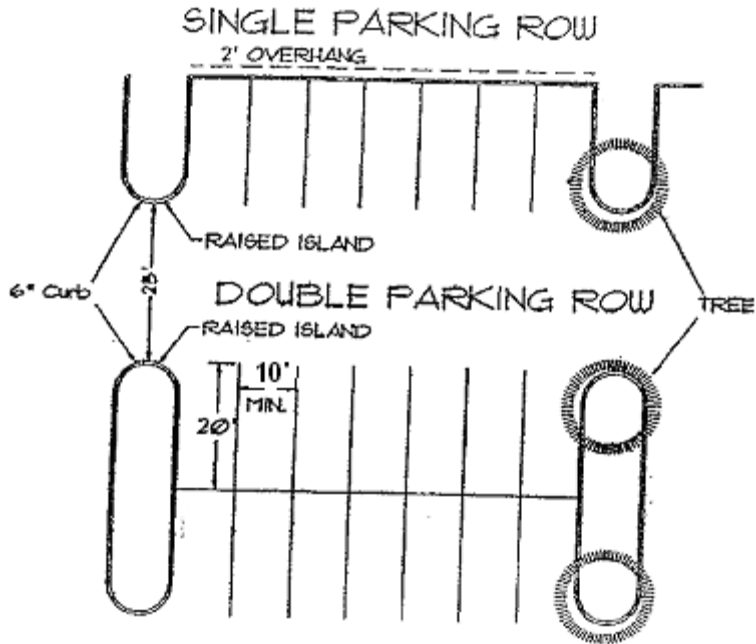

NOTES: Maximum of 20 spaces between islands on peripheral row
 Maximum of 15 spaces between islands on interior row

F. Separation of right-of way and parking areas.

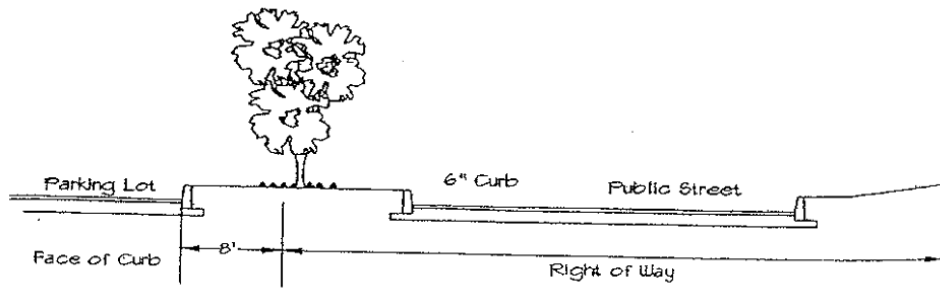

G. Landscaping and fencing.

