



**MEETING AGENDA**  
**Planning & Zoning Commission**  
**REGULAR SESSION PLANNING & ZONING COMMISSION**  
**July 2, 2025**

**HAL BALDWIN MUNICIPAL COMPLEX COUNCIL CHAMBERS**  
**1400 SCHERTZ PARKWAY BUILDING #4**  
**SCHERTZ, TEXAS 78154**

**CITY OF SCHERTZ CORE VALUES**  
**Do the right thing**  
**Do the best you can**  
**Treat others the way you want to be treated**  
**Work cooperatively as a team**

**AGENDA**  
**WEDNESDAY, JULY 2, 2025 at 6:00 p.m.**

**The Planning and Zoning Commission will hold the regularly scheduled meeting at 6:00p.m., Wednesday, July 2, 2025, at the City Council Chambers. In lieu of attending the meeting in person, residents will have the opportunity to watch the meeting via live stream on the City's YouTube Channel.**

**1. CALL TO ORDER**

**2. SEAT ALTERNATE TO ACT IF REQUIRED**

**3. HEARING OF RESIDENTS**

*This time is set aside for any person who wishes to address the Planning and Zoning Commission. Each person should fill out the Speaker's register prior to the meeting. Presentations should be limited to no more than three (3) minutes. Discussion by the Commission of any item not on the agenda shall be limited to statements of specific factual information given in response to any inquiry, a recitation of existing policy in response to an inquiry, and/or a proposal to place the item on a future agenda. The presiding officer, during the Hearing of Residents portion of the agenda, will call on those persons who have signed up to speak in the order they have registered.*

**4. CONSENT AGENDA:**

**A.** Minutes for the June 04, 2025 Regular Meeting.

**5. PUBLIC HEARING:**

*The Planning and Zoning Commission will hold a public hearing related to zone change requests, specific use permit requests, and Unified Development Code Amendments within this agenda. The public hearing will be opened to receive a report from staff, the applicant, the adjoining property owners affected by the applicant's request, and any other interested persons. Upon completion, the public hearing will be closed. The Commission will discuss and consider the application, and may*

*request additional information from staff or the applicant, if required. After deliberation, the Commission is asked to consider and act upon the following requests and make a recommendation to the City Council if necessary.*

- A. **PLZC20250094** - Hold a public hearing and make a recommendation on a request to rezone approximately 4.64 acres of land from General Business District (GB) to General Business District-2 (GB-2), generally known as 36 Maske Road and 40 Maske Road, Lots 1 and 2, Block 1 of the Maske Road Business Park Subdivision, more specifically known as Guadalupe County Property Identification Numbers 199114, and 199115.

**6. ITEMS FOR INDIVIDUAL CONSIDERATION:**

- A. **PLVAR20250144 Sign Waiver** - Consider and act upon a request for a waiver in relation to wall signage for the Home Depot on Lot 10 Block 1 of the Schertz Station Subdivision, approximately 18.709 acres of land, located at 18541 Ripss-Kreusler Road, Schertz, Texas, 78154, more specifically known as Guadalupe County Parcel Identification Number 68313.

**7. WORKSHOP AND DISCUSSION:**

- A. Workshop and Discussion on the City of Schertz Development Process- Requested by Chairman Outlaw November 6, 2024
- B. Workshop and Discussion on distance requirements between car washes- Requested by Commissioner Wallace on May 7, 2025

**8. REQUESTS AND ANNOUNCEMENTS:**

- A. Requests by Commissioners to place items on a future Planning and Zoning Agenda
- B. Announcements by Commissioners
  - City and community events attended and to be attended
  - Continuing education events attended and to be attended
- C. Announcements by City Staff.
  - City and community events attended and to be attended.

**9. INFORMATION AVAILABLE IN THE PLANNING AND ZONING COMMISSION PACKETS- NO DISCUSSION TO OCCUR**

- A. Current Projects and City Council Status Update

**10. ADJOURNMENT OF THE REGULAR MEETING**

**CERTIFICATION**

I, Daisy Marquez, Planner, of the City of Schertz, Texas, do hereby certify that the above agenda was posted on the official bulletin boards on this the 26th day of June, 2025 at 10:30 a.m., which is a place readily accessible to the public at all times and that said notice was posted in accordance with chapter 551, Texas Government Code.



Daisy Marquez, Planner

**I certify that the attached notice and agenda of items to be considered by the Schertz Planning & Zoning Commission was removed from the official bulletin board on \_\_\_\_ day of \_\_\_\_\_, 2025. \_\_\_\_\_ title: \_\_\_\_\_**

*This facility is accessible in accordance with the Americans with Disabilities Act. Handicapped parking spaces are available. If you require special assistance or have a request for sign interpretative services or other services please call 619-1030 at least 24 hours in advance of meeting.*

The Planning and Zoning Commission for the City of Schertz reserves the right to adjourn into executive session at any time during the course of this meeting to discuss any of the matters listed above, as authorized by the Texas Open Meetings Act.

Executive Sessions Authorized: This agenda has been reviewed and approved by the City's legal counsel and presence of any subject in any Executive Session portion of the agenda constitutes a written interpretation of Texas Government Code Chapter 551 by legal counsel for the governmental body and constitutes an opinion by the attorney that the items discussed therein may be legally discussed in the closed portion of the meeting considering available opinions of a court of record and opinions of the Texas Attorney General known to the attorney. This provision has been added to this agenda with the intent to meet all elements necessary to satisfy Texas Government Code Chapter 551.144(c) and the meeting is conducted by all participants in reliance on this opinion.



**PLANNING AND ZONING COMMISSION MEETING: 07/02/2025**

**Agenda Item 4 A**

TO: Planning and Zoning Commission  
PREPARED BY: Sarah Rodriguez, Administrative Assistant  
SUBJECT: Minutes for the June 04, 2025 Regular Meeting.

---

**Attachments**

Draft Minutes for the June 04, 2025 Regular Meeting

# DRAFT

## PLANNING AND ZONING MINUTES

June 4, 2025

The Schertz Planning and Zoning Commission convened on June 4, 2025 at 6:24 p.m. at the Municipal Complex, Council Chambers, 1400 Schertz Parkway Building #4, Schertz, Texas.

Present: Glen Outlaw, Chairman; Richard Braud, Vice Chairman; Judy Goldick, Commissioner; David Hughes, Commissioner; Tamara Brown, Commissioner; John Carbon, Commissioner; Patrick McMaster, Commissioner

Absent: Roderick Hector, Commissioner; Clayton Wallace, Commissioner

Staff present: Brian James, Deputy City Manager  
Lesa Wood, Director of Planning & Community Development  
Kathy Woodlee, City Engineer  
Larry Busch, Director of Public Works  
Daisy Marquez, Planner  
Sarah Rodriguez, Administrative Assistant

### 1. CALL TO ORDER / ROLL CALL THE REGULAR PLANNING & ZONING COMMISSION MEETING

Chairman Outlaw called the meeting to order at 6:24 P.M.

### 2. SEAT ALTERNATE TO ACT IF REQUIRED

Commissioner David Hughes was seated as an alternate.

### 3. HEARING OF RESIDENTS

*This time is set aside for any person who wishes to address the Planning and Zoning Commission. Each person should fill out the Speaker's register prior to the meeting. Presentations should be limited to no more than three (3) minutes. Discussion by the Commission of any item not on the agenda shall be limited to statements of specific factual information given in response to any inquiry, a recitation of existing policy in response to an inquiry, and/or a proposal to place the item on a future agenda. The presiding officer, during the Hearing of Residents portion of the agenda, will call on those persons who have signed up to speak in the order they have registered.*

No one spoke.

### 4. CONSENT AGENDA:

#### A. Minutes for the May 7, 2025 Regular Meeting.

There was no discussion.

Motioned by Commissioner Patrick McMaster, seconded by Commissioner John Carbon to approve

**Vote:** 7 - 0 Passed

**5. PUBLIC HEARING:**

*The Planning and Zoning Commission will hold a public hearing related to zone change requests and replats within this agenda. The public hearing will be opened to receive a report from staff, the applicant, the adjoining property owners affected by the applicant's request, and any other interested persons. Upon completion, the public hearing will be closed. The Commission will discuss and consider the application, and may request additional information from staff or the applicant, if required. After deliberation, the Commission is asked to consider and act upon the following requests and make a recommendation to the City Council if necessary.*

- A. PLZC20250105** - Hold a public hearing and make a recommendation on a request to rezone approximately 19 acres of land from Single-Family Residential / Agricultural District (R-A) to Middle Density Residential District (R-5) known as Guadalupe County Property Identification Number 68302, and 68303, also known as 19018 Old Wiederstein Road, City of Schertz, Guadalupe County, Texas

Mrs. Marquez gave a presentation on PLZC20250105. The applicant, Patrick Christensen, gave a presentation.

Chairman Outlaw opened up the Public Hearing at 6:37 P.M.

- John Jasek-19108 Old Wiederstein Road
- Mark Tudick-18940 Old Wiederstein Road
- Ruben Hernandez-18967 Old Wiederstein Road
- Teresa Gomez (Brandon spoke on her behalf)-19094 Old Wiederstein Road

Chairman Outlaw closed the Public Hearing at 6:45 P.M.

Motioned by Commissioner John Carbon, seconded by Commissioner Patrick McMaster to recommend approval of PLZC20250105 to the City Council.

**Vote:** 6 - 1 Passed

NAY: Commissioner Tamara Brown

- B. PLZC20240315** - Hold a public hearing and make a recommendation on a request to rezone approximately 173 acres of land from Agricultural District (AD) and Single-Family Residential / Agricultural District (R-A) to Single-Family Residential District (R-1), Single-Family Residential District (R-2), and Single-Family Residential District (R-6), known as Bexar County Property Identification Number 310012, 309425, 309427, generally located 1,000 feet to the west of Cibolo Creek on Lower Seguin Road, City of Schertz, Bexar County, Texas

Mrs. Marquez gave a presentation on PLZC20240315. The applicant, Paul Landa, spoke.

Chairman Outlaw opened up the Public Hearing at 7:17 P.M.

No one spoke.

Chairman Outlaw closed the Public Hearing at 7:17 P.M.

Motioned by Commissioner Patrick McMaster, seconded by Commissioner John Carbon to recommend approval of PLZC20240315 to City Council.

**Vote:** 7 - 0 Passed

- C. PLUDC20250123-** Conduct a public hearing, workshop, and discussion and possible action to make a recommendation on amendments to Part III of the Schertz Code of Ordinance, Unified Development Code (UDC), to Article 8 Section 21.8.9 - Outdoor Display and Storage.

Mrs. Marquez gave a presentation on PLUD20250123.

Chairman Outlaw opened up the Public Hearing at 7:35 P.M.

No one spoke.

Chairman Outlaw closed the Public Hearing at 7:35 P.M.

Motioned by Commissioner Judy Goldick, seconded by Vice Chairman Richard Braud to recommend approval of PLUDC20250123 to City Council with conditions.

**Vote:** 7 - 0 Passed

**6. REQUESTS AND ANNOUNCEMENTS:**

- A.** Requests by Commissioners to place items on a future Planning and Zoning Agenda

No request were made.

- B.** Announcements by Commissioners

- City and community events attended and to be attended
- Continuing education events attended and to be attended

No announcements were made.

- C.** Announcements by City Staff.

- City and community events attended and to be attended.

There were announcements made by staff.

**7. INFORMATION AVAILABLE IN THE PLANNING AND ZONING COMMISSION PACKETS- NO DISCUSSION TO OCCUR**

- A.** Current Projects and City Council Status Update

**8. ADJOURNMENT OF THE REGULAR MEETING**

**Chairman Outlaw adjourned the regular meeting at 7:52 P.M.**

---

Chairman, Planning and Zoning Commission

---

Recording Secretary, City of Schertz



<b>Existing</b>	(GB)	General Business District	10,000	100	100	20	0	0	120	80%
<b>Proposed</b>	(GB-2)	General Business District-2	10,000	100	100	20	0	0	120	80%

**COMMUNITY BENEFIT**

It is the City’s desire to promote safe, orderly, efficient development and ensure compliance with the City’s vision of future growth.

**SUMMARY OF RECOMMENDED ACTION**

**1. Whether the proposed zoning change implements the policies of the adopted Comprehensive Land Plan, or any other applicable adopted plans.**

The Comprehensive Land Plan is a guiding document for the long-range vision of Schertz and designates this area as "Industrial Hub." Industrial Hub is intended for developments such as manufacturing warehouses, processing, and distribution centers, and can buffer industrial areas to transition to other land uses by developing flex buildings or research and development. The applicant is requesting a zone change from General Business District (GB) to General Business District-2 (GB-2) to develop flex industrial buildings for office-warehouse use. Office-warehouse land use is consistent with the Industrial Hub designation and thus implements the policies established by the Comprehensive Land Plan.

**2. Whether the proposed zoning change promotes the health, safety, and general welfare of the City.**

As part of promoting health, safety, and general welfare, zone change requests should align with the Unified Development Code (UDC) and city policy. The subject property is located within the Air Installation Compatible Use Zone District (AICUZ). More specifically, this property is located within the Accident Potential Zone II (APZ II). These zones are established to provide control on encroachment around a military airfield per UDC Sec. 21.5.9.A, which requires that Randolph Air Force Base (RAFB) affirmatively recommend to the City that the proposed zone change be permitted. Based upon an evaluation of noise pollution and the high risk potential of aircraft accidents, RAFB has affirmatively recommended the zone change request from General Business District (GB) to General Business District-2 (GB-2). Therefore, the proposed zone change aligns with the UDC and city policy.

**3. Whether the uses permitted by the proposed change will be consistent and appropriate with existing uses in the immediate area.**

The subject property is currently undeveloped and is located directly adjacent to an area with numerous properties zoned as General Business District-2 (GB-2). General Business District-2 (GB-2) is intended to provide suitable areas for the development of non-residential and light industrial uses that serve the entire community. Additionally, two properties in the same subdivision were approved for a similar zone change by City Council on June 3rd, 2025. Therefore, given the current conditions of the surrounding area, a rezone to General Business District-2 (GB-2) does meet the intent of the UDC and is appropriate with the existing uses in the immediate area. The land uses permitted in General Business District-2 (GB-2) are listed in UDC Section 21.5.8 -Permitted Use Table.

*Permitted Use Table (Sec. 21.5.8)\**

	<b>Existing Zoning District</b>	<b>Proposed Zoning District</b>
	<i>General Business District (GB)</i>	<i>General Business District-2 (GB-2)</i>
<b>Permitted Uses</b>	<ul style="list-style-type: none"> <li>● Appliances, Furniture and Home Furnishing Store</li> <li>● Building Material and Hardware Sales</li> <li>● Car Wash, Automated</li> <li>● Commercial Amusement, Indoor</li> </ul>	<ul style="list-style-type: none"> <li>● Appliances, Furniture and Home Furnishing Store</li> <li>● Building Material and Hardware Sales</li> <li>● Car Wash, Automated</li> <li>● Commercial Amusement, Indoor</li> <li>● Auto Repairs and Service, Major</li> <li>● Office Warehouse/Distribution Center</li> <li>● Mini-Warehouse/Public Storage (SUP)</li> </ul>

\*The permitted use table shown is a non-exhaustive list. For a complete list of permitted uses, see UDC Section 21.5.8-Permitted Use Table

**4. Whether other factors are deemed relevant and important in the consideration of the amendment.**

All UDC requirements have been met for the proposed zone change. City of Schertz Fire, EMS, and Police Departments have been notified of the zone change and have provided no objections to the request. JBSA Randolph has been notified of the zone change request by the City of Schertz and, per the 2017 Air Installations Compatible Use Zones (AICUZ) Study, JBSA finds warehousing and storage services to be permitted within this area of the Accident Potential Zone (APZ) II with a maximum Floor-to-Area Ratio (FAR) of 2.0. Per their independent review, JBSA affirmatively recommends approval of the zone change request.

**RECOMMENDATION**

Due to the character of the surrounding area, the consistency with the Comprehensive Land Plan, and the affirmative recommendation of the proposed zone change from JBSA Randolph, staff recommends approval of PLZC20250094.

---

**Attachments**

Aerial Exhibit

Public Hearing Notice Map

Public Hearing Notice Response

Zoning Exhibit

JBSA Letter

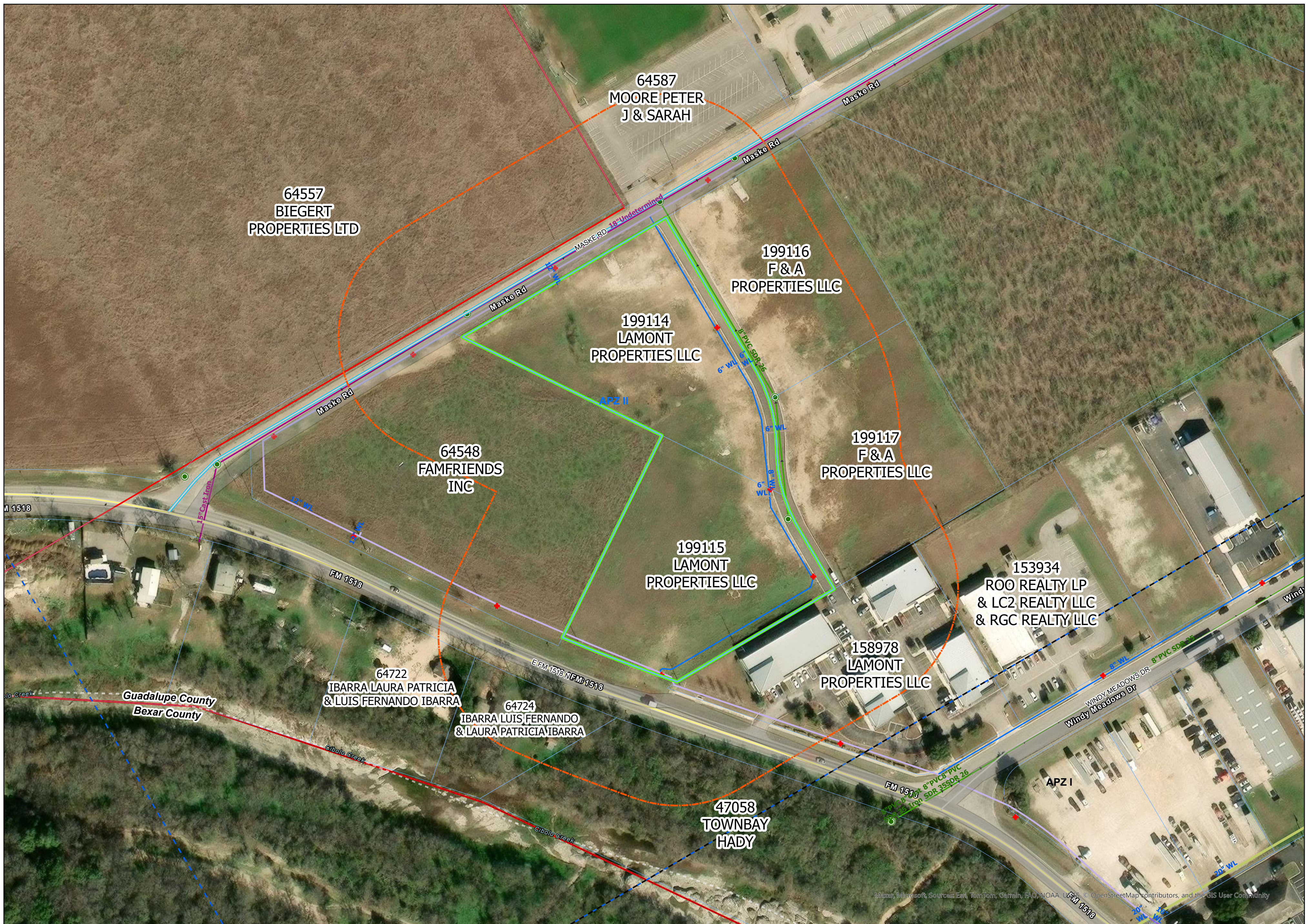

Map: Microsoft, Source: Esri, TomTom, Garmin, FAO, NOAA, USGS, OpenStreetMap contributors, and the GIS User Community

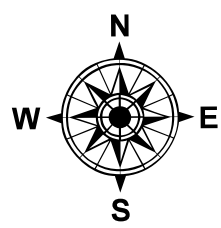

**SCHIERTZ**  
COMMUNITY • SERVICE • OPPORTUNITY

PARCEL IDs:  
199114 & 199115

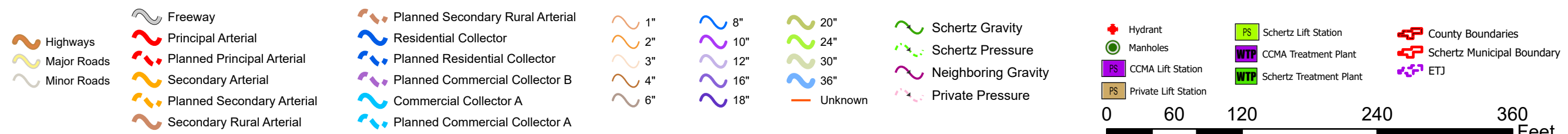



# City of Schertz

Parcel IDs:  
199114 & 199115



Project Boundary

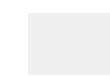

City Limits

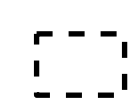

Schertz ETJ  
Boundary



200' Buffer

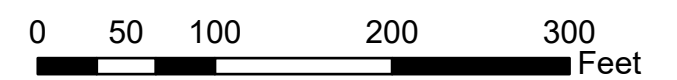
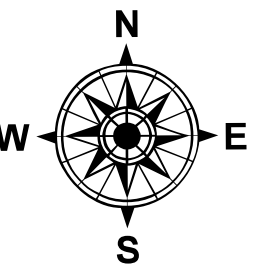

**Public Comment on Zoning Case PLZC20250094**

---

**From** [REDACTED]  
**Date** Fri 6/20/2025 4:46 PM  
**To** planning <planning@schertz.com>  
**Cc** William Willingham <wwillingham@schertz.com>; Daisy Marquez <dmarquez@schertz.com>

Dear Planning Division,

I am writing to express my support for the proposed zoning change under case PLZC20250094, scheduled for public hearing on July 2, 2025.

As the new owner of the adjacent properties located at 44 and 46 Maske Road, which I officially acquired today, I fully support the request to rezone 36 and 40 Maske Road from General Business District (GB) to General Business District-2 (GB-2). I believe this change will promote consistent and compatible development in the area and contribute positively to the ongoing growth of the Maske Road Business Park.

Please consider this note as my formal recommendation in favor of the proposed zoning change.

Best regards,  
Jesús Solana

# CURRENT

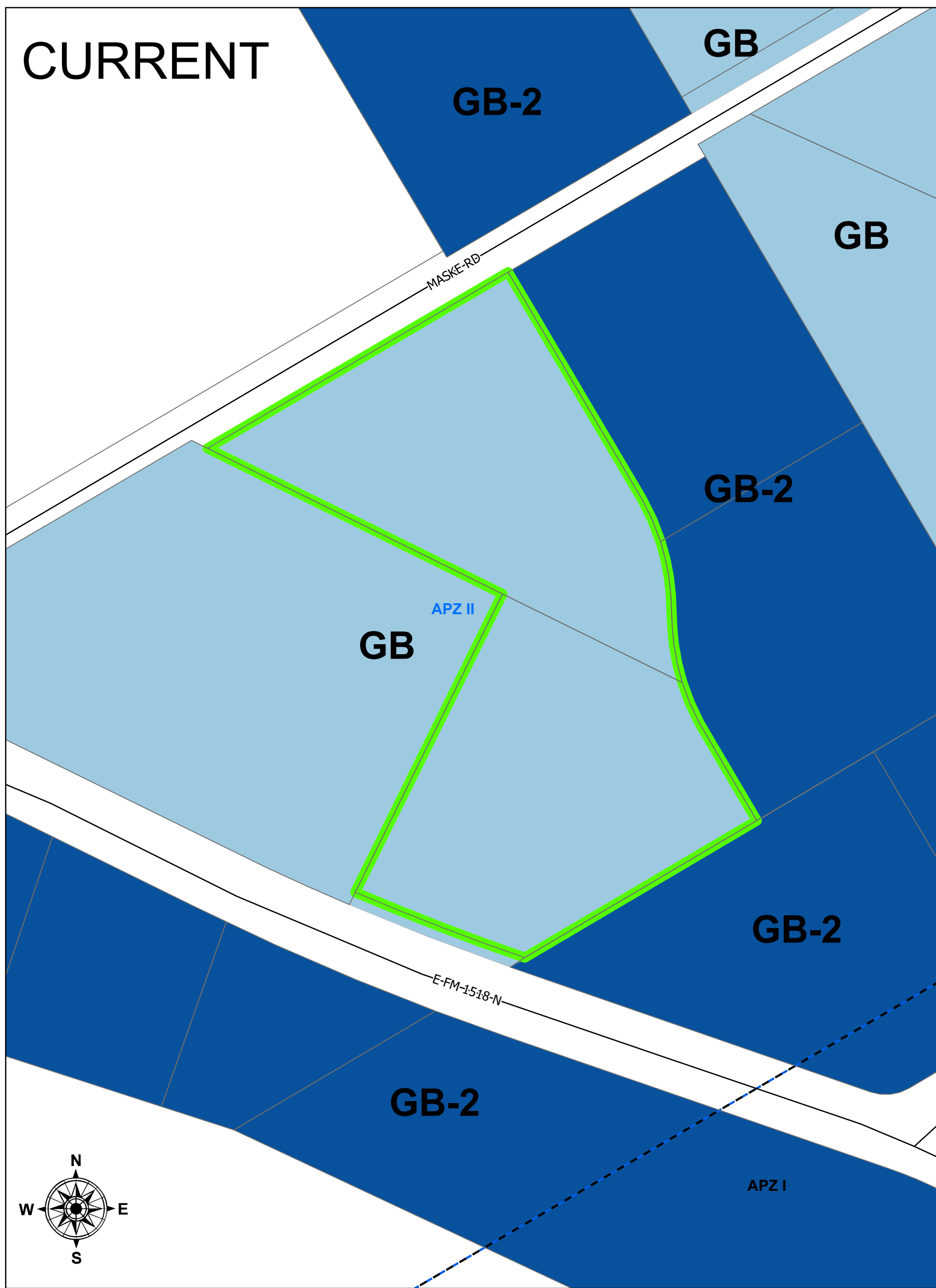

# PROPOSED

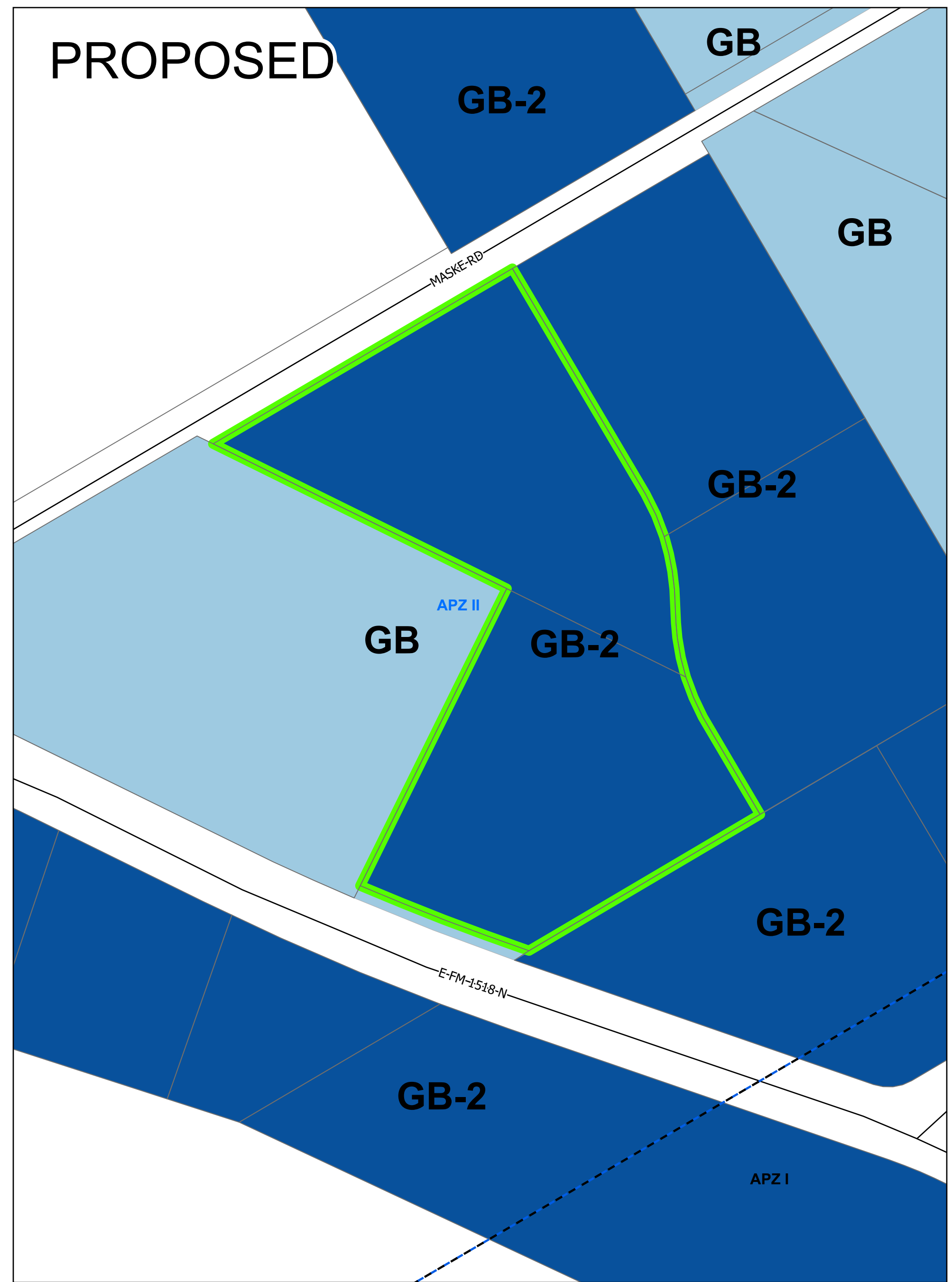

Last update: June 12th, 2025  
 City of Schertz, GIS Specialist: Alexa Venezia, [avenezia@schertz.com](mailto:avenezia@schertz.com) (210) 619-1174

\*The City of Schertz provides this Geographic Information System product "as is" without any express or implied warranty of any kind including but not limited to the implied warranties of merchantability and fitness for a particular purpose. In no event shall The City of Schertz be liable for any special, indirect, or consequential damages or any damages whatsoever arising out of or in connection with the use of or performance of these materials. Information published in this product could include technical inaccuracies or typographical errors. Periodical changes may be added to the information herein. The City of Schertz may make improvements and/or changes in the product(s) described herein at any time.\*

## PROPOSED ZONING CHANGE

### GUADALUPE COUNTY PARCEL IDs: 199114 & 199115

Classification	
	(PRE) Pre-Development
	(PDD) Planned Development
	(PUB) Public Use
	(R-A) Single-family Residential/Agricultural
	(R-1) Single-Family Residential
	(R-2) Single-Family Residential
	(R-3) Two-Family Residential
	(R-4) Apartment/Multi-Family Residential
	(R-5) Middle Density District
	(R-6) Single-family Residential
	(R-7) Single-family Residential
	(AD) Agricultural District
	(GH) Garden Home/Single-Family Residential (Zero Lot Line)
	(TH) Townhome
	(MHS) Manufactured Home Subdivision
	(MHP) Manufactured Home Parks
	(GB) General Business
	(GB-2) General Business II
	(NS) Neighborhood Services
	(OP) Office and Professional
	(MSMU) Main Street Mixed Use
	(MSMU-ND) Main Street Mixed Use New Development
	(M-1) Manufacturing (Light)
	(M-2) Manufacturing (Heavy)
	(DVL) Development Agreement (Delayed Annexation)

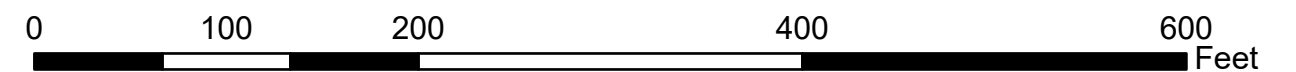



**DEPARTMENT OF THE AIR FORCE  
502D AIR BASE WING  
JOINTBASE SAN ANTONIO**



12 May 2025

MEMORANDUM FOR CITY OF SCHERTZ

FROM: 502 ABW/CMI

JBSA Installation Mission Sustainment  
2080 Wilson Way  
Fort Sam Houston, TX 78234

SUBJECT: Joint Base San Antonio review of Zone Change in APZ II PLZC20250094-Maske Road Business Park (36 & 40 Maske Road)

1. Zone Change in APZ II PLZC20250094-Maske Road Business Park (36 & 40 Maske Road) has been reviewed by JBSA-RND organizations. JBSA affirmatively recommends the proposed zoning change is permitted, however, there are additional comments for consideration in planning and development.
  - a. Subject parcel is located within Randolph AFB Accident Potential Zone II (APZ II). Per the 2017 RND Air Installations Compatible Use Zones (AICUZ) study, Warehousing and storage services, SLUCM No. 63.7, is permitted within APZ II with a maximum Floor-to-Area Ratio (FAR) of 2.0. Retail trade, SLUCM No. 50, is generally permitted within APZ II with a maximum FAR of .28. The majority of Office services, to include Misc Services (SLUCM no. 69) are permitted w/in APZ II with maximum FAR of .22. Additionally, due to the proximity to the primary approach/departure flight tracks of RND AFB, expect regular and increasing levels of noise.

<https://www.jbsa.mil/Portals/102/Documents/Environmental%20PA/FINAL%20Randolph%20AICUZ%20Study.pdf>
  - b. Recommend referencing City of San Antonio MLOD lighting standards at: [https://library.municode.com/tx/san\\_antonio/codes/unified\\_development\\_code?nodeId=ARTII\\_IZO\\_DIV4OVDI\\_S35-339.04MILIOVDI](https://library.municode.com/tx/san_antonio/codes/unified_development_code?nodeId=ARTII_IZO_DIV4OVDI_S35-339.04MILIOVDI), or most current City of San Antonio MLOD ordinance, related to development within 5-miles of a military installation and compliance with applicable City of Schertz lighting ordinances.
  - c. To mitigate potential interference with existing JBSA operational systems, please coordinate with 502 CS Spectrum Manager prior to use of any Spectrum dependent systems (i.e.: two-way radio communications, or any type of wireless technologies) during construction. If applicable, coordination requested by facility user prior to installation/use of any Spectrum dependent commercial or manufacturing equipment.
  - d. Any proposed exterior construction plans, construction or alteration projects which include vertical elements (equipment: cranes, towers: communication or water) may require FAA review to verify no hazard to flight navigation prior to issuance of any construction permits.

FAA CFR Title 14 Part 77 Notice Criteria Tool that can be utilized to aid in FAA notification requirements can be found here:

<https://oeaaa.faa.gov/oeaaa/external/gisTools/gisAction.jsp?action=showNoNoticeRequiredToofForm>

Further FAA guidance is also available here:

[https://www.faa.gov/documentLibrary/media/Form/FAA\\_Form\\_7460-1\\_042023.pdf](https://www.faa.gov/documentLibrary/media/Form/FAA_Form_7460-1_042023.pdf)

- e. The FAA recommends criteria of land-use practices in their Advisory Circular 150/5200-33C, Hazardous Wildlife Attractants on or Near Airports, which is applicable to properties within five miles of JBSA-Randolph. To reduce the exposure to aircraft-wildlife strikes, please use the link below to access this publication and use the information to help reduce wildlife-attractant features near airports. Unwavering consideration for this aviation safety hazard is vital. [https://www.faa.gov/airports/resources/advisory\\_circulars/index.cfm/go/document.current/documentnumber/150\\_5200-33](https://www.faa.gov/airports/resources/advisory_circulars/index.cfm/go/document.current/documentnumber/150_5200-33).
2. The items presented above are efforts to enhance the safety of the community and minimize noise impacts due to the proximity of low flying aircraft. Improperly managed development may create unnecessary risk to both the community and flight operations as well as affect the overall capability of the military at this location.
3. Point of contact for this action is Sean R. Greszler, AICP, 502 ABW/CMI. He can be reached at 210-808-7549 or by email at [sean.greszler.1@us.af.mil](mailto:sean.greszler.1@us.af.mil) or through the 502d ABW Community Initiatives organization email box at [502ABW.ABW.Community\\_initiative@us.af.mil](mailto:502ABW.ABW.Community_initiative@us.af.mil).

**WOLIVER.T**  
**IMOTHY.A.**  
**1076286708**

Digitally signed by  
WOLIVER.TIMOTHY.A.1076286708  
Date: 2025.05.13  
15:25:14 -05'00'

MR. TIM WOLIVER, GS-14, USAF  
Executive Director, Community and  
Mission Integration, JBSA & 502 ABW



**PLANNING AND ZONING COMMISSION MEETING: 07/02/2025**  
**Agenda Item 6 A**

TO: Planning and Zoning Commission  
PREPARED BY: Samuel Haas, Senior Planner  
CASE: PLVAR20250144  
SUBJECT: **PLVAR20250144 Sign Waiver** - Consider and act upon a request for a waiver in relation to wall signage for the Home Depot on Lot 10 Block 1 of the Schertz Station Subdivision, approximately 18.709 acres of land, located at 18541 Ripss-Kreusler Road, Schertz, Texas, 78154, more specifically known as Guadalupe County Parcel Identification Number 68313.

---

**GENERAL INFORMATION:**

Owner: Ripps Kreusler, LTD  
Applicant: Amy Noble, Kimly-Horn

**ITEM SUMMARY:**

The Schertz City Council recently passed updates to Article 11 - Signs and Advertising Devices on June 17, 2025 as Ord. 25-S-024. In these updates, is Section 21.11.15 Waivers. This section allows applicants the opportunity to request waivers from the sign standards in extenuating circumstances. These requests are then decided upon by the Schertz Planning and Zoning Commission.

The applicant intends to construct a 136,466-square-foot Home Depot on Lot 10 Block 1 of the Schertz Station subdivision, a large mixed-use subdivision consisting of multifamily housing and restaurant / retail sites on the corner of Cibolo Valley Drive and IH-35. The waiver request is in relation to the new wall sign requirements.

Wall signs under the new Article 11 updates have an allowable square footage of signage available per facade. This can be either 1 sign for the full square footage or multiple signs that add up to the maximum allowable square footage for signage. The amount of square footage is determined based off of roadway classification and the address of the site.

The address for the Home Depot is 18541 Ripps-Kreusler, which has a roadway classification as "All Others" and would give the applicant 100 square feet of available signage. Additionally, because the applicant is constructing a building over 100,000 square feet, the applicant is allowed an additional 100 square feet, for a total of 200 square feet of allowable signage. The applicant is requesting a waiver from that requirement and would like the allowable signage area to be increased to 580 square feet for the front facade facing Station Road to the north towards IH-35.

**GENERAL LOCATION AND SITE DESCRIPTION:**

The site is 18541 Ripps-Kreusler otherwise known as Lot 10 Block 1 of the Schertz Station subdivision, a large mixed-use subdivision consisting of multifamily housing and restaurant / retail sites on the corner of Cibolo Valley Drive and IH-35.

**PUBLIC IMPROVEMENTS:**

The Schertz Station subdivision is constructing a number of public improvements, including sanitary sewer, water, roadway and other utility improvements.

**STAFF ANALYSIS AND RECOMMENDATION:**

The Planning and Zoning Commission uses the criteria in 21.11.15 for sign waivers and staff use the same for our analysis.

**21.11.15.B has the the following considerations:**

**1. The nature of the proposed use of the land involved.**

The Schertz Station Subdivision is a large subdivision currently zoned Planned Development District (PDD). The subdivision as a whole consists of multifamily-style housing and several retail / restaurant sites. The site for this specific waiver is a large proposed home improvement center that is set back approximately 800 feet from IH35. Given the nature of the shopping center-style land use as a whole and the particular location of the home improvement center, staff feels that additional signage area for the front of the building is appropriate.

**2. The location of the property in relation to roadway classification.**

Several public roadways provide access to the subdivision. That being said, Schertz Station functions effectively as a regional destination center on the corner of IH-35 and Cibolo Valley Drive. Article 11 determines roadway classification based on addressing and Staff has determined that this requirement is not appropriate for this particular site. It would be more appropriate to classify Home Depot as adjacent to IH35.

**3. The existing uses of land in the vicinity.**

The land uses in the vicinity consist of the remainder of the Schertz Station subdivision which, as mentioned above, consists of multifamily-style housing and several retail / restaurant sites. Additionally, the EVO site is adjacent to the property.

**21.11.15.C has the following considerations:**

**1. That the granting of the waiver will not be detrimental to the public health, safety, or welfare, or injurious to other property in the area**

The granting of this waiver would not be detrimental to the health, safety and general welfare. Home Depot acts as an anchor tenant and would help drive commercial activity for the surrounding properties.

**2. Strict interpretation of the provisions of the section would deprive the applicant of rights commonly enjoyed by other nearby properties with the same land use that would comply with the same provisions.**

The neighboring EVO sight has a similar location and setback approximately 1000 feet from the frontage of IH35. As part of their Planned Development District zone change request (Ord.18-S-37), they were allowed to have a 478 sq. ft. front wall sign. Staff has determined that the Home Depot has a similar situation and thus a waiver would be in-line with what other properties have been allowed to do.

Staff does not support the request to increase allowable wall signage space to 580 square feet. Under the new code updates passed on June 17, 2025, properties located on interstates are allowed a maximum signage space of 250 square feet, and buildings that are over 100,000 square feet in size are allotted an additional 100 square feet. If applied to only the front-facing facade, this would provide Home Depot a maximum of 350 square feet of wall signage space, and Staff has determined this amount to be more appropriate and more in-line with the intent of the UDC. The other facades in which signage is permitted would remain capped at 200 sq. ft. of signage area, as stipulated in the UDC.

Therefore, Staff is recommending approval of the waiver request with the condition that the maximum allowable wall signage for the front-facing facade be increased to 350 square feet as the new Article 11 provides, and not to 580 square feet as the applicant has requested.

<b>Planning Department Recommendation</b>	
	Approve as submitted
<b>X</b>	Approve with conditions*
	Denial

\* While the Commission can impose conditions; conditions should only be imposed to meet requirements of the UDC.

**COMMISSIONERS CRITERIA FOR CONSIDERATION:**

**Unified Development Code Sec. 21.11.15 - Waivers**

A. The Planning and Zoning Commission may authorize waivers from the provisions of this Article when, in its opinion, undue hardship will result from requiring strict compliance. In granting a waiver, the Planning and Zoning Commission shall prescribe only conditions that it deems necessary or desirable to the public interest.

B. In making their findings, the Planning and Zoning Commission shall take into account the following:

1. The nature of the proposed use of the land involved.
2. The location of the property in relation to roadway classification.
3. The existing uses of land in the vicinity.

C. Waivers shall not be granted unless the Planning and Zoning Commission finds:

1. That the granting of the waiver will not be detrimental to the public health, safety, or welfare, or injurious to other property in the area; and
2. Strict interpretation of the provisions of the section would deprive the applicant of rights commonly enjoyed by other nearby properties with the same land use that would comply with the same provisions.

---

---

**Attachments**

Applicant Waiver Justification

Sign Waiver Exhibits

Site Plan

Ord. 25-S-024 with Exhibits



6/13/2025

City of Schertz  
Planning and Community Development  
1400 Schertz Parkway  
Schertz, TX 78154

### **Home Depot Schertz – Wall Sign Size Waiver Request**

Home Depot is proposing to build a new retail store in Schertz, TX. The Site Certification Package for this project has been submitted with the assigned reference number PLSPC20240209. This project is part of the Schertz Station Planned Development District (PDD). For this PDD, the City of Schertz Unified Development Code (UDC) adopted in June 2025 allows for wall sign size to be up to 100 SF plus an additional 100 SF because The Home Depot building is over 100,000 SF, resulting in a maximum wall sign area of 200 SF per building façade (Article 11 Sec. 21-11-9).

The Home Depot is proposing four wall signs that total approximately 580 SF on the front building façade. The 580 SF proposed is larger than the 200 SF allowed by code. Because of this, The Home Depot is requesting a waiver to increase the maximum sign area allowance from 200 SF to 580 SF for the building façade facing Station Road or IH-35.

Home Depot is requesting a waiver to increase the wall sign size due to the following reasons:

- The front building façade is 580' long and 37' tall with an approximate front area of 21,460 SF and will need a larger sign than the code allows. The total proposed wall sign square footage (580 SF) only covers 2.7% of the building front façade area.
- The Home Depot proposed store is in the Schertz Station PDD as a commercial land use and will be surrounded by other commercial land uses. No residential land uses are adjacent to the Home Depot property. The nearest residential land use is approximately 1500 feet away and does not face the Home Depot building façade with the proposed wall signs.
- The Schertz Station PDD is directly adjacent to the Interstate-35 frontage road. The UDC allows for wall sign size increases if the property is adjacent to an interstate. The Home Depot is part of the Schertz Station PDD and is requesting a wall sign size due to the proximity to the interstate.

Attachments:

- Site Plan
- Wall Sign Plan
- Project Location Exhibit

Please reach out if you have any questions.

Thank you,

A handwritten signature in black ink that reads "Austin Edelen". The signature is written in a cursive, flowing style.

Austin Edelen, PE

Kimley-Horn & Associates

Site Development Coordinator Team for The Home Depot, Inc.

## SIGN CODE WAIVER JUSTIFICATION FORM UDC 21.11.15:

The Planning and Zoning Commission may authorize waivers from the provisions of this Article when, in its opinion, undue hardship will result from requiring strict compliance. In granting a waiver, the Planning and Zoning Commission shall prescribe only conditions that it deems necessary or desirable to the public interest. Please answer the following questions below.

1. Description of waiver request and Unified Development Code (UDC) section the project or request is from:

Home Depot is proposing to build a new retail store in Schertz, TX. This project is part of the Schertz Station Planned Development District (PDD). For this PDD, the City of Schertz Unified Development Code (UDC) adopted in June 2025 allows for wall sign size to be up to 100 SF plus an additional 100 SF, because The Home Depot building is over 100,000 SF, resulting in a maximum wall sign area of 200 SF per building façade (Article 11 Sec. 21-11-9). The Home Depot is proposing four wall signs that total approximately 580 SF on the front building façade. Because of this, The Home Depot is requesting a waiver to increase the maximum sign area allowance from 200 SF to 580 SF for the building façade facing Station Road or IH-35.

2. Does the requested waiver violate the intent of the Unified Development Code or deprive the applicant of right commonly enjoyed by other properties in the same zoning district that comply with the same provisions? (YES/NO) Explain:

No it does not violate intent of code. Code intends for buildings near interstate to have larger signs and for large buildings to have larger signs. The front building facade is 580' long and 37' tall with an approximate front area of 21,460 SF. The total proposed wall sign square footage (580SF) only covers 2.7% of the building front facade area.

3. Do special conditions or restricted access, shape, topography, or physical features exist that are irregular to the subject parcel of land and not applicable to other parcels of land in the same zoning districts? (YES/NO) Explain:

Proximity to interstate without being directly adjacent. Parcels directly adjacent are allowed to increase sign size. HD is near but not directly adjacent and is therefore not allowed by code to increase wall sign size. The HD parcel is larger than other commercial parcels and is therefore, farther away from public ROW and roadways. Because of this, HD needs a larger sign to be visible to drivers.

4. Would granting this waiver be detrimental to the public welfare or injurious to the value of property in the vicinity? (YES/NO) Explain:

Granting this waiver would not be detrimental to the public welfare or injurious to the value of property in the vicinity because we are still adhering to the code section regarding materials of the sign, overall design, number of signs, etc. The increase in wall sign will only help customers see the location of the main store, garden center, lumber canopy, and tool rental area. HD is part of a commercial PDD and all surrounding properties are commercial land uses.

\\kimley-horn.com\ISO\_ALP\ALP\_PR\1000\_THD\_New Retail Stores\Sites\Schertz\_TX\CAD\Exhibits\THD\_SCHERTZ\_TX - SITE LOCATION EXHIBIT.dwg OVERALL Jun 12, 2025 9:51am by: Josemaria Espinoza



**Kimley >> Horn**  
11720 AMBER PARK DRIVE, SUITE 600, ALPHARETTA, GEORGIA 30009  
PHONE: (770) 619-4280 | www.kimley-horn.com

TITLE:  
**HD PROJECT LOCATION EXHIBIT**

PROJECT:  
**THD SCHERTZ, TX**

CLIENT:  
**THE HOME DEPOT**

JOB NUMBER: SS-02906.2001  
SCALE: 1" = 150'  
DATE: 06/12/2025  
SHEET: **EXHIBIT A**

THIS DOCUMENT, TOGETHER WITH THE CONCEPTS AND DESIGNS PRESENTED HEREIN, AS AN INSTRUMENT OF SERVICE, IS INTENDED ONLY FOR THE SPECIFIC PURPOSE AND CLIENT FOR WHICH IT WAS PREPARED. REUSE OF AND IMPROPER RELIANCE ON THIS DOCUMENT WITHOUT WRITTEN AUTHORIZATION AND ADAPTATION BY KIMLEY-HORN AND ASSOCIATES, INC. SHALL BE WITHOUT LIABILITY TO KIMLEY-HORN AND ASSOCIATES, INC. COPYRIGHT KIMLEY-HORN AND ASSOCIATES, INC. 2017

# I-35 & Cibolo Valley Road - Schertz, Texas 78108

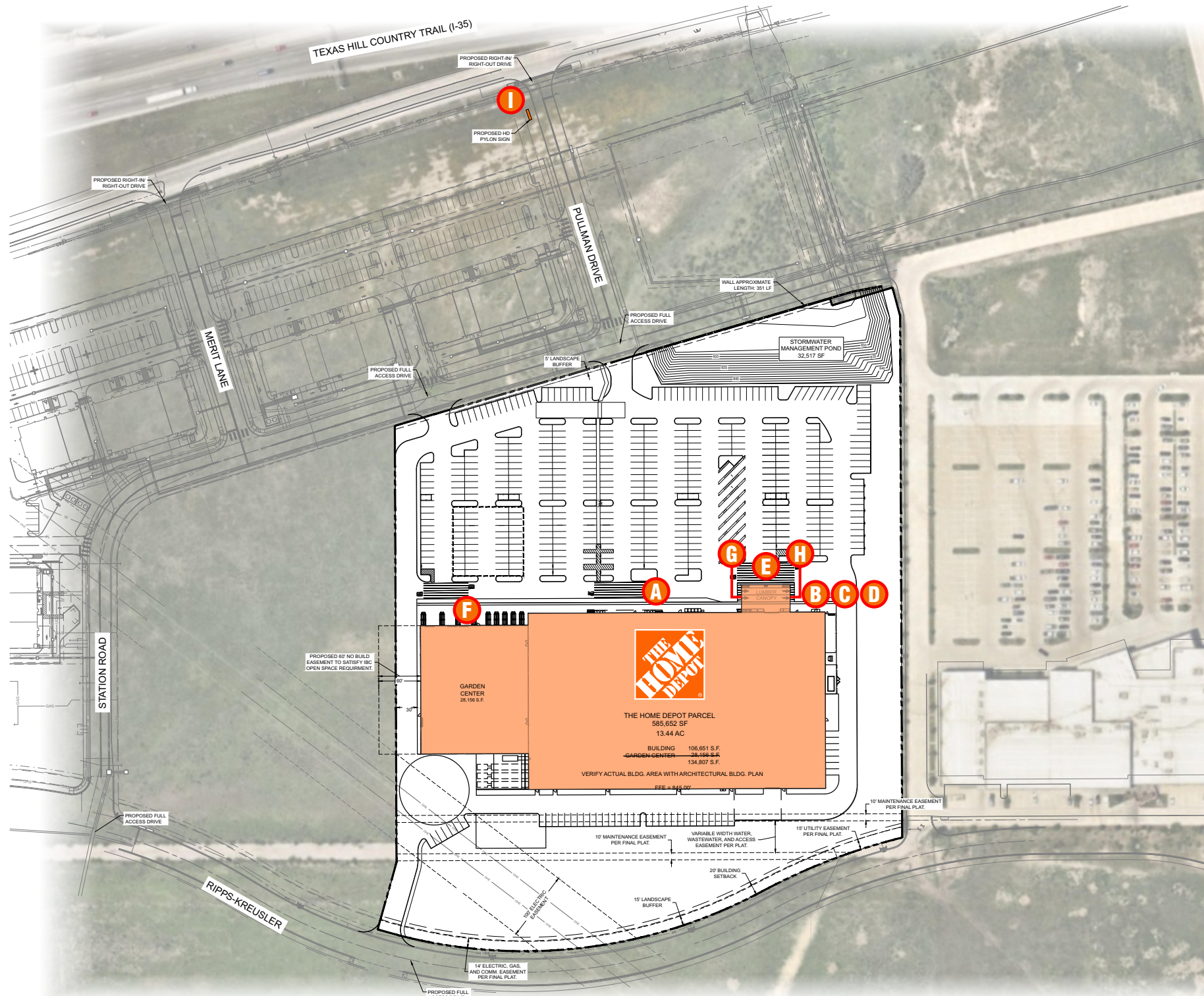

## NEW THD SIGNS

- A** 6'-0" THE HOME DEPOT LED CHANNEL LETTERS
- B** 3'-0" TOOL RENTAL LED SIGN
- C** 12" X 12" NEW TOOL RENTAL STORE HOUR SIGN
- D** 12" X 12" NEW TOOL RENTAL ENTRANCE SIGN
- E** 2'-6" LUMBER LED CHANNEL LETTERS
- F** 2'-6" GARDEN CENTER LED CHANNEL LETTERS
- G** ENTRANCE CLEARANCE PANEL (NON-ILLUMINATED)
- H** EXIT CLEARANCE PANEL (NON-ILLUMINATED)
- I** 8'-0" X 8'-0" THD MONUMENT @ 20' OAH (96 SF)



1771 Industrial Road, Dothan, Alabama 36303  
 (888) 303-5534 (334) 836-1401  
 www.idassociatesinc.com



CLIENT: THE HOME DEPOT

LOCATION: SCHERTZ, TEXAS

ACCOUNT REP: KEVIN CRAMER

DRAWING NO: THD-SCHERTZ\_TX #TBD-SIGN EXHIBIT

STORE NO: TBD

DATE: 06/10/25

DRAWN BY: JAS

REV:

REV:

REV:

REV:

REV:

REV:

REV:

REV:

REV:

EXHIBIT APPROVED BY:

# I-35 & Cibolo Valley Road - Schertz, Texas 78108

NOTE: INSTALL DIMENSIONS SUBJECT TO CHANGE WHEN SCALABLE ELEVATIONS BECOME AVAILABLE.

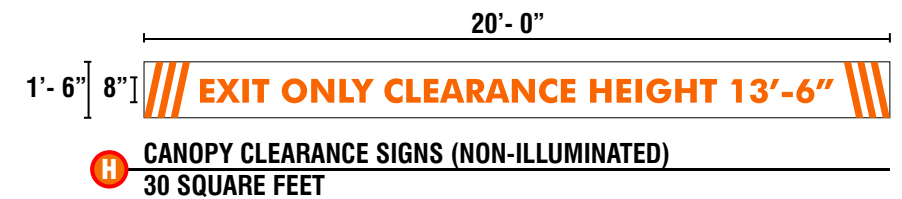
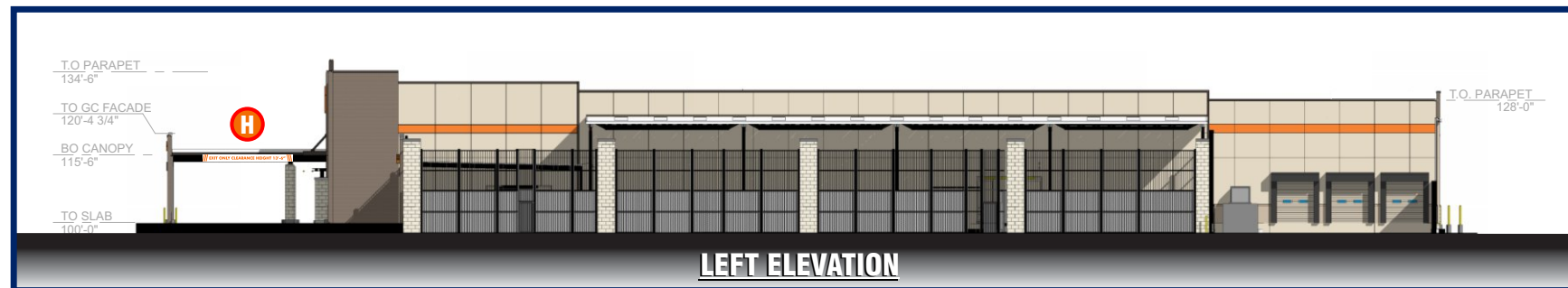
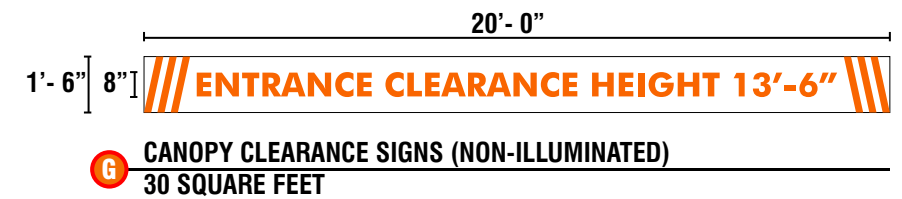
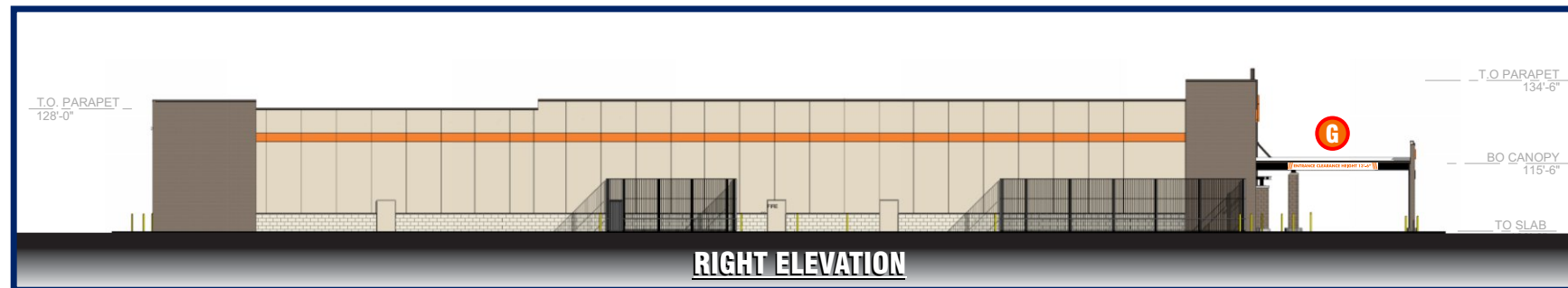
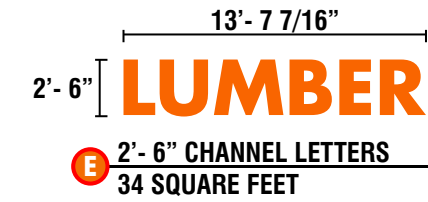
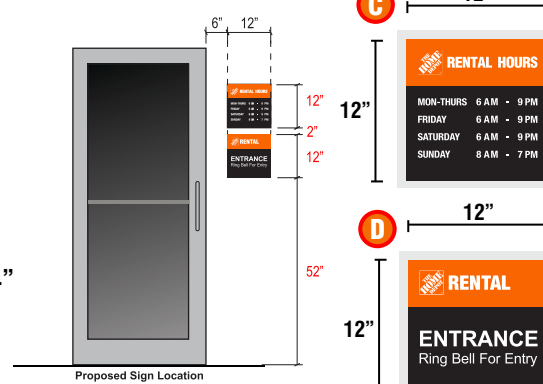
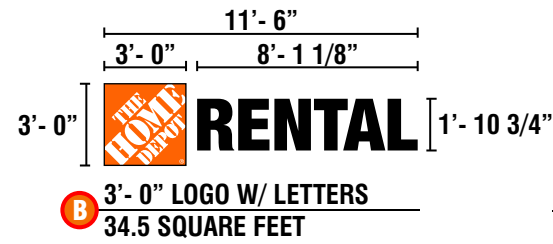
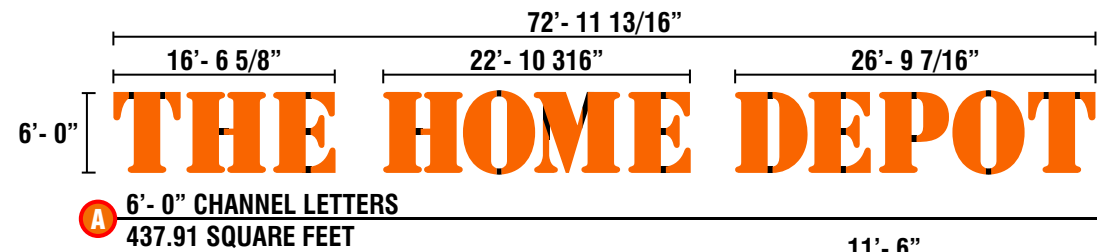
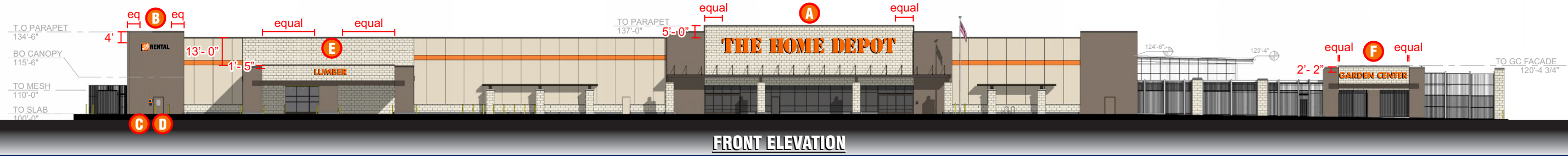

# I-35 & Cibolo Valley Road - Schertz, Texas 78108

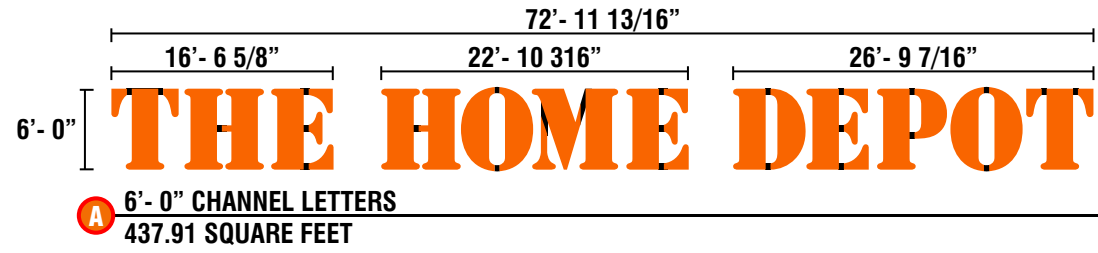

	A	B	C	D	E	A X B = SQ. FT.
1" Black Trimcap	3'-0"	36'-5 15/16"	8'-3 3/16"	11'-5 1/16"	13'-4 11/16"	109.48
	3'-6"	42'-6 7/8"	9'-7 11/16"	13'-3 15/16"	15'-7 1/2"	149.01
Aluminum Retainers	4'-0"	48'-7 7/8"	11'-0 3/16"	15'-2 3/4"	17'-10 1/4"	194.63
	4'-6"	54'-8 7/8"	12'-4 3/4"	17'-1 5/8"	20'-1 1/16"	246.33
	5'-0"	60'-9 7/8"	13'-9 1/4"	19'-0 1/2"	22'-3 13/16"	304.11
	5'-6"	66'-10 13/16"	15'-1 13/16"	20'-11 5/16"	24'-6 5/8"	367.96
	6'-0"	72'-11 13/16"	16'-6 5/16"	22'-10 3/16"	26'-9 7/16"	437.91
	6'-6"	79'-0 13/16"	17'-10 13/16"	24'-9"	29'-0 3/16"	513.94
	7'-0"	85'-1 13/16"	19'-3 3/8"	26'-7 7/8"	31'-3"	596.06

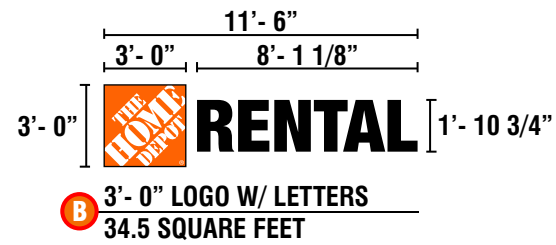

	A	B	C	D	A X D = SQ. FT.
*STANDARD SIZE	1'-0"	7 1/2"	2'-8 3/8"	3'-10"	3.8
	1'-8"	12 1/2"	4'-6"	6'-4 5/8"	10.6
	2'-0"	1'-3 3/16"	5'-4 3/4"	7'-8"	15.33
	*3'-0"	1'-10 3/4"	8'-1 1/8"	11'-6"	34.5
	4'-0"	2'-6 3/8"	10'-9 7/16"	15'-4"	61.33

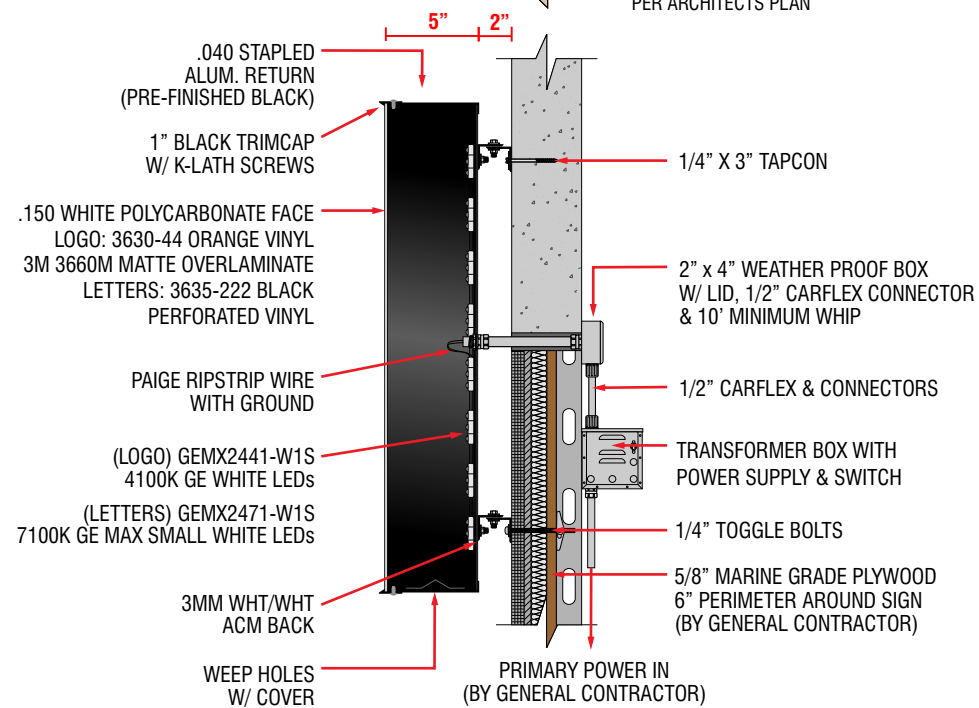
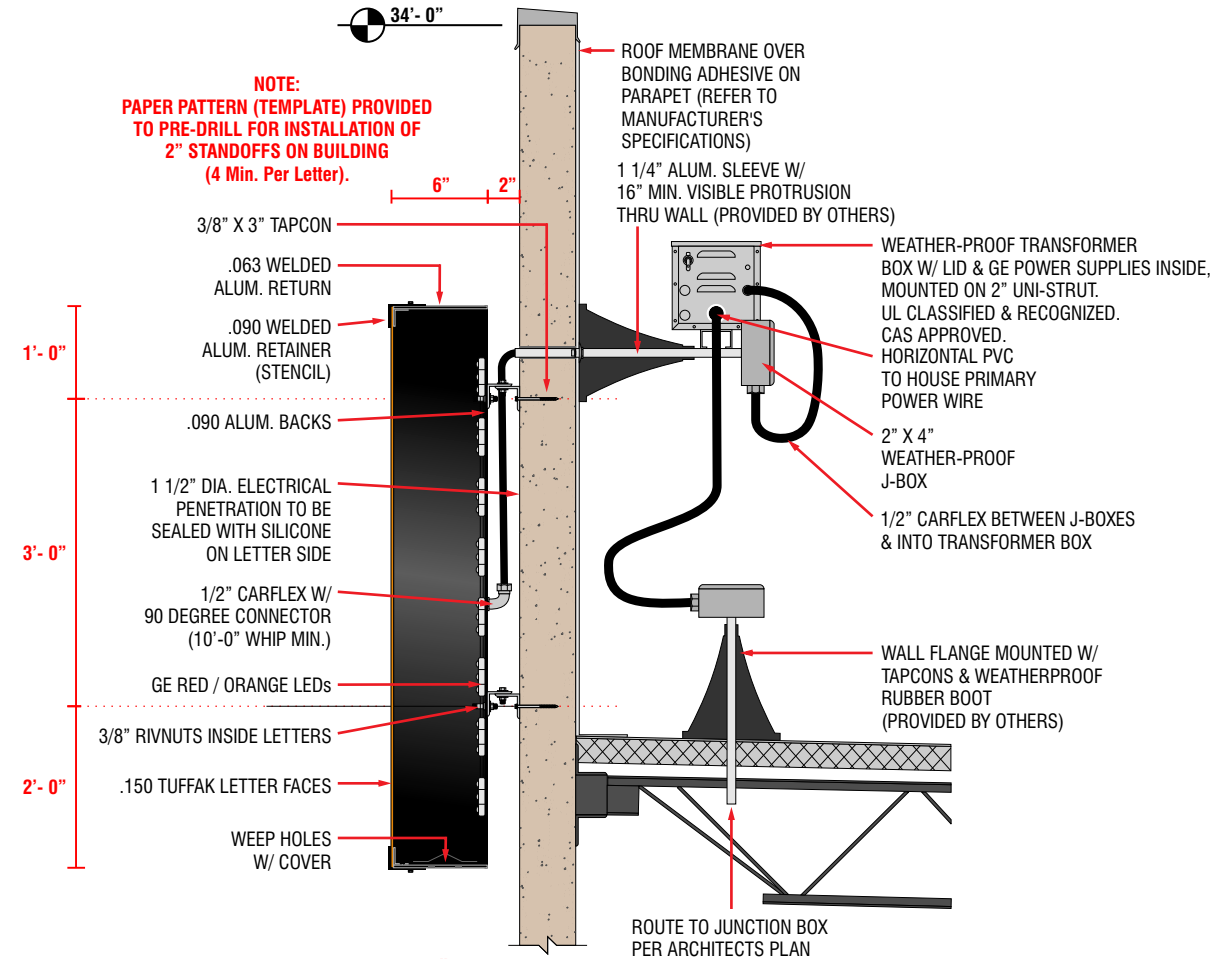

# I-35 & Cibolo Valley Road - Schertz, Texas 78108

13'- 7 7/16"  
 2'- 6"  
**LUMBER**  
 E 2'- 6" CHANNEL LETTERS  
 34 SQUARE FEET

A	B	A X B = SQ. FT.
1'- 0"	5'- 5 3/8"	5.45
1'- 6"	8'- 2 1/16"	12.26
2'- 0"	10'- 10 3/4"	21.8
*2'- 6"	13'- 7 7/16"	34
3'- 0"	16'- 4 1/8"	49

\*STANDARD SIZE

28'- 9"  
 14'- 7"      12'- 8 3/4"  
 2'- 6"  
**GARDEN CENTER**  
 F 2'- 6" CHANNEL LETTERS  
 72 SQUARE FEET

A	B	C	D	A X B = SQ. FT.
1'- 0"	11'- 6"	5'- 10"	5'- 1 3/8"	11.5
1'- 6"	17'- 3"	8'- 9"	7'- 7 11/16"	25.88
2'- 0"	23'- 0"	11'- 8"	10'- 2 3/16"	46
*2'- 6"	28'- 9"	14'- 7"	12'- 8 3/4"	71.88
3'- 0"	34'- 6"	17'- 6"	15'- 3 5/16"	103.5

\*STANDARD SIZE

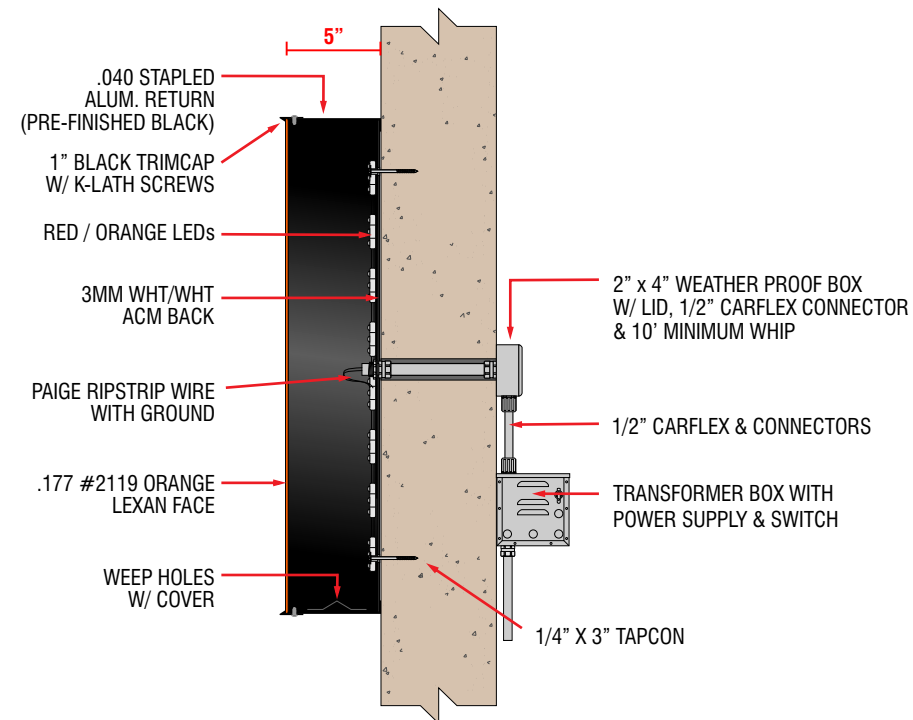
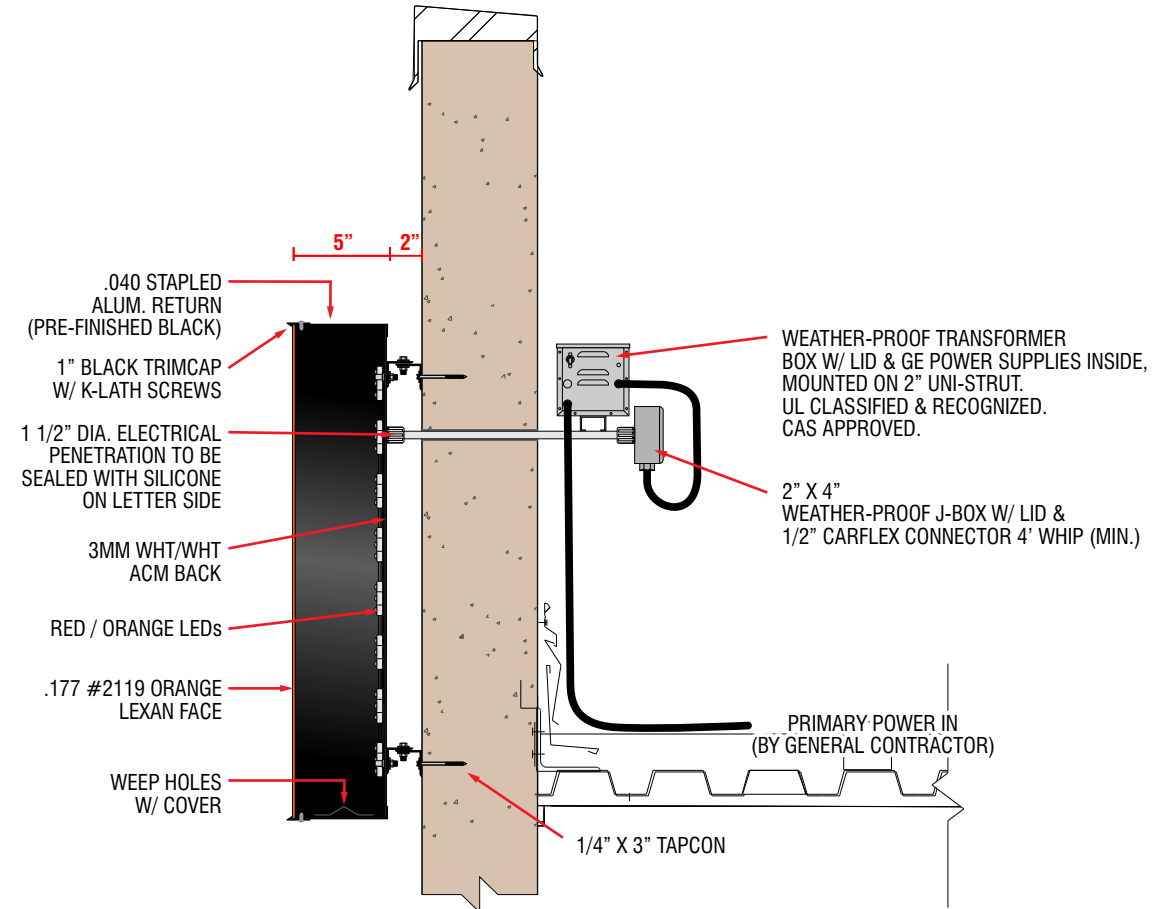

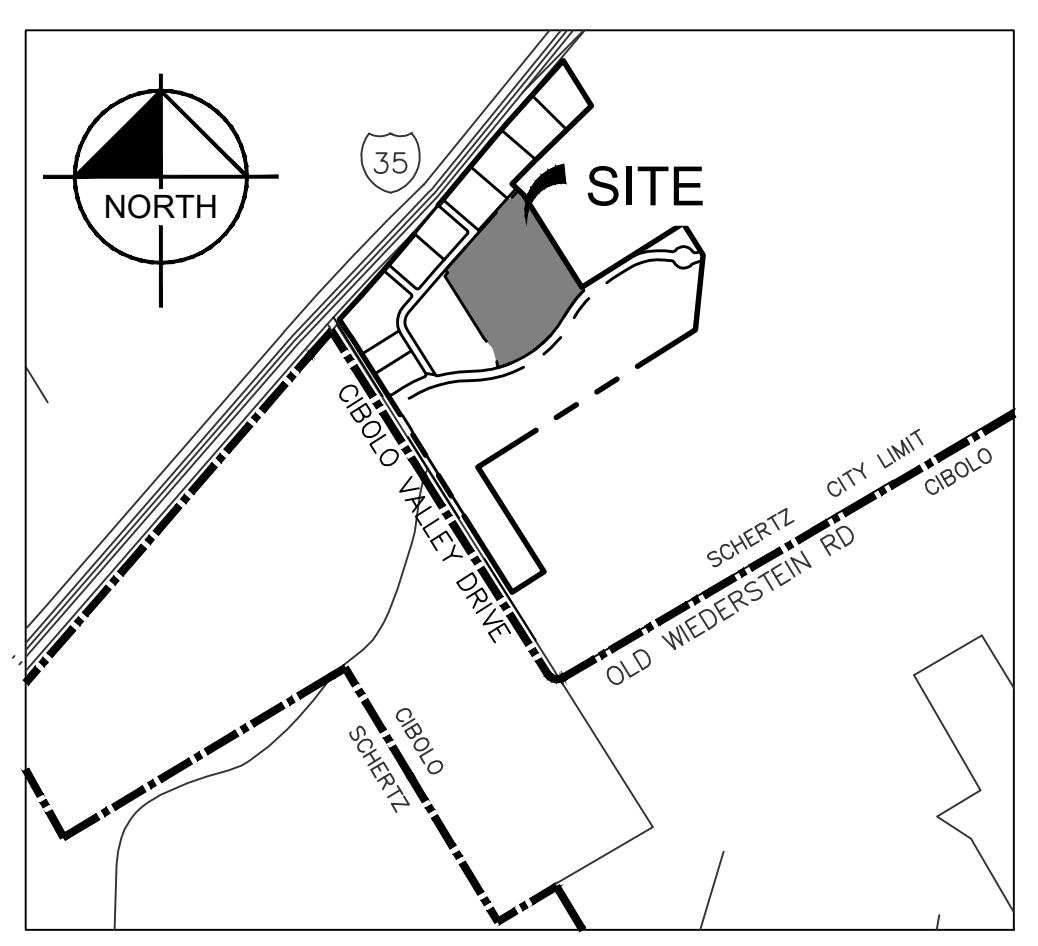

VICINITY MAP

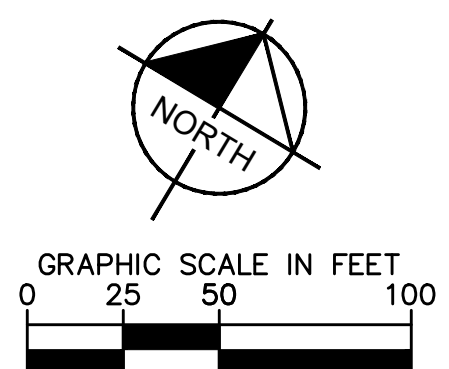

**LEGEND**

[Symbol]	PROPERTY BOUNDARY
[Symbol]	HOSE LAY
[Symbol]	PROPOSED FIRE LANE
[Symbol]	PROPOSED SANITARY SEWER MANHOLE
[Symbol]	PROPOSED ACCESSIBLE PARKING SPACE
[Symbol]	PROPOSED BARRIER FREE RAMP
[Symbol]	PROPOSED SANITARY SEWER LINE
[Symbol]	PROPOSED WATER LINE
[Symbol]	PROPOSED GAS LINE
[Symbol]	PROPOSED UNDERGROUND ELECTRIC LINE
[Symbol]	PROPOSED UNDERGROUND COMMUNICATION LINE
[Symbol]	PROPOSED STORM DRAIN LINE
[Symbol]	EXISTING SANITARY SEWER LINE
[Symbol]	EXISTING WATER LINE
[Symbol]	EXISTING GAS LINE
[Symbol]	EXISTING OVERHEAD ELECTRIC LINE
[Symbol]	EXISTING STORM DRAIN LINE
[Symbol]	PROPOSED SANITARY SEWER MANHOLE
[Symbol]	PROPOSED CLEANOUT
[Symbol]	PROPOSED FIRE HYDRANT
[Symbol]	PROPOSED FIRE DEPARTMENT CONNECTION
[Symbol]	PROPOSED WATER METER
[Symbol]	PROPOSED BACKFLOW PREVENTER
[Symbol]	PROPOSED VALVE
[Symbol]	PROPOSED FITTING
[Symbol]	PROPOSED GAS METER
[Symbol]	PROPOSED POWER POLE
[Symbol]	PROPOSED TRANSFORMER
[Symbol]	PROPOSED CURB INLET
[Symbol]	EXISTING SANITARY SEWER MANHOLE
[Symbol]	EXISTING CLEANOUT
[Symbol]	EXISTING FIRE HYDRANT
[Symbol]	EXISTING WATER METER
[Symbol]	EXISTING VALVE
[Symbol]	EXISTING POWER POLE
[Symbol]	GAS MANIFOLD
[Symbol]	PROPOSED PERVIOUS LANDSCAPE
[Symbol]	GOODS TRAFFIC FLOW
[Symbol]	TRAFFIC FLOW ARROWS

**FLOODPLAIN NOTE:**  
 1. ACCORDING TO FLOOD INSURANCE RATE MAP, PANEL 48187C0210F, DATED NOVEMBER 2, 2007, IS LOCATED IN ZONE(S) "AE" AND "X" AND IS WITHIN THE 100-YEAR FLOODPLAIN.  
 2. ANY DEVELOPMENT SHALL BE IN ACCORDANCE WITH FLOODPLAIN ORDINANCED IN EFFECT AT THE TIME OF CONSTRUCTION APPLICATION.

**SITE DATA TABLE**

GENERAL SITE DATA	
CURRENT DESCRIPTION	LOT 10, BLOCK 1 (SCHERTZ STATION SUBDIVISION - LOT 1-10, 12 - BLOCK 1) (VOL. 10, PG. 277-283)
CURRENT ZONING	PLANNED DEVELOPMENT DISTRICT
PROPOSED LAND USE	COMMERCIAL
SITE ACREAGE	LOT 17 PER REPLAT = 13.445 A.C. (585,657 SQFT) LOT 10 = 18,709 A.C. (814,960 SQFT)
ADDRESS	18541 RIPPS KREUSLER RD.
BUILDING DATA (PRECAST)	REFERENCE ARCHITECTURAL ELEVATION SHEETS
FLOOR AREA RATIO	0.23
BUILDING HEIGHT	37'
BUILDING SQUARE FOOTAGE	THE HOME DEPOT = 108,001 SQFT GARDEN CENTER = 28,465 SQFT TOTAL = 136,466 SQFT
IMPERVIOUS COVER (MAX 90% PER PDD)	9.4 ACRES (409,293 SQFT) ( 69.9%)
PERVIOUS COVER (MIN 10% PER PDD)	4.05 ACRES (176,364 SQFT) ( 30.1%)
<b>PARKING DATA</b>	
STANDARD SPACES PROVIDED	396 SPACES
ACCESSIBLE SPACES PROVIDED	10 SPACES
TOTAL SPACES PROVIDED	406 SPACES (SEE PARKING REDUCTION MEMO)
TOTAL SPACES REQUIRED (4 STALLS/ 1000 BLDG. SQFT)	THE HOME DEPOT (108,001 SQFT) = 433 STALLS GARDEN CENTER (28,465 SQFT) = 114 STALLS TOTAL STALLS = 547 STALLS
REFERENCE ORDINANCE NO. 22-S-44 FOR AREA I REQUIREMENTS. *AREA I SHALL COMPLY WITH CITY OF SCHERTZ GENERAL BUSINESS DISTRICT STANDARDS PER PDD CHAPTER 3, SECTION C.C. (IN SUCH CASES) THE CITY MANAGER OR HIS/HER DESIGNEE MAY REDUCE THE PARKING REQUIRED FOR USES WITHIN PDD AREA II BY UP TO TWENTY-FIVE PERCENT (25%).*	

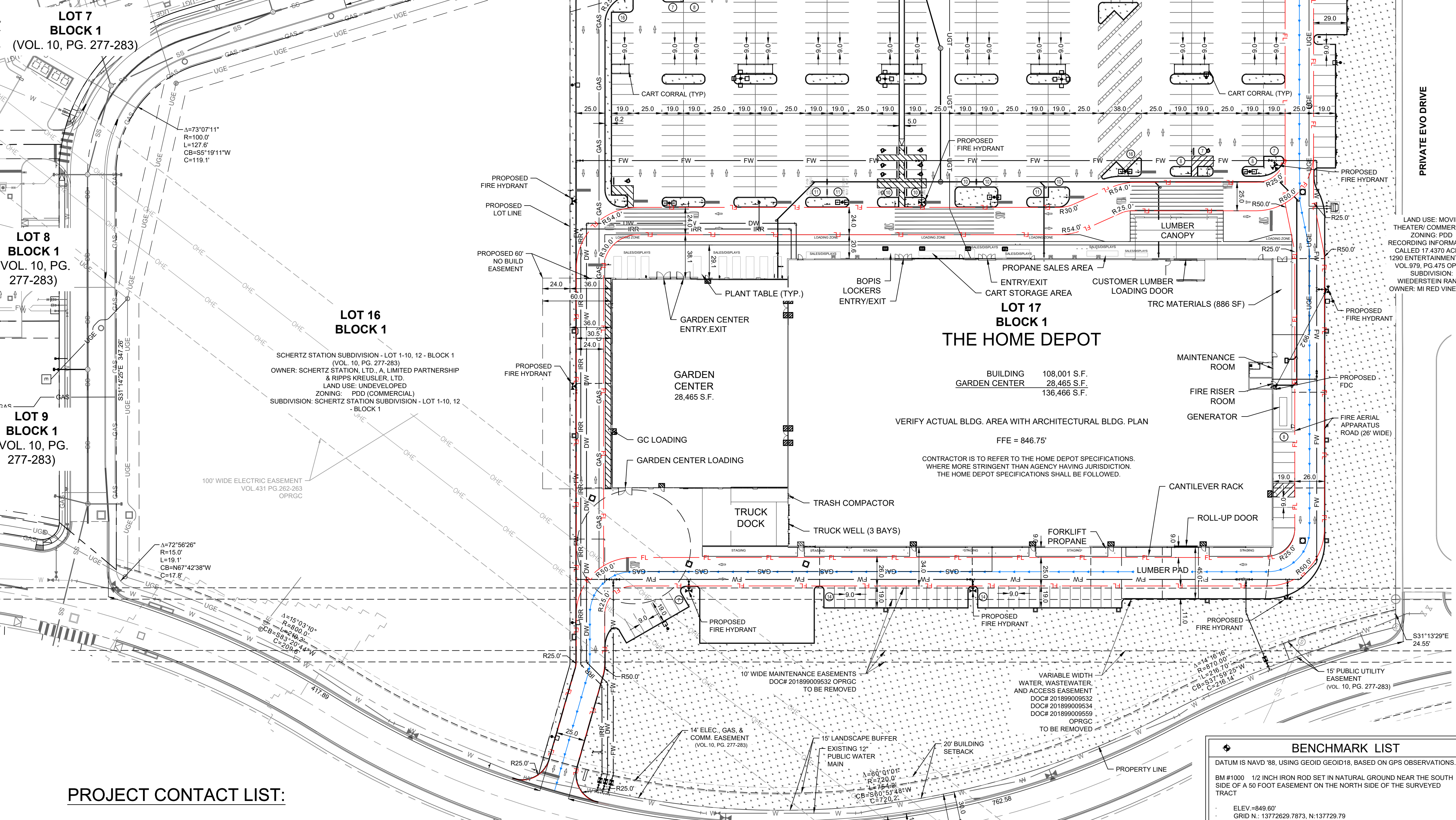

**PROJECT CONTACT LIST:**

**SURVEYOR OF RECORD**  
 KIMLEY-HORN  
 10101 REUNION PL, STE 400  
 SAN ANTONIO, TEXAS 78216  
 PHONE: 210-541-9166  
 CONTACT: JOHN GREGORY MOSIER, R.P.L.S.

**CIVIL ENGINEER**  
 KIMLEY-HORN  
 10101 REUNION PL, SUITE 400  
 SAN ANTONIO, TEXAS 78216  
 PHONE: 210-541-3421  
 CONTACT: AMY NOBLE, P.E.

**PROPERTY OWNER**  
 RIPPS KREUSLER, LTD.  
 4040 BROADWAY SUITE 600  
 SAN ANTONIO, TX 78209  
 PHONE: 210-541-2005  
 CONTACT: WILL COLLINS

**DEVELOPER**  
 THE HOME DEPOT  
 2455 PACES FERRY ROAD, C-19  
 ATLANTA, GA 30339  
 MOBILE: 678-814-9177  
 CONTACT: CORBIN ROWE



**BENCHMARK LIST**

DATUM IS NAVD '88, USING GEOID GEOID18, BASED ON GPS OBSERVATIONS.

BM #1000 1/2 INCH IRON ROD SET IN NATURAL GROUND NEAR THE SOUTH SIDE OF A 50 FOOT EASEMENT ON THE NORTH SIDE OF THE SURVEYED TRACT

- ELEV = 849.60'
- GRID N: 13772629.7873, N: 137729.79
- GRID E: 2209566.3221, E: 2209566.32

BM #1001 1/2 INCH IRON ROD SET IN NATURAL GROUND NEAR THE NORTH SIDE OF A 50 FOOT EASEMENT ON THE NORTH SIDE OF THE SURVEYED TRACT

- ELEV = 838.43'
- GRID N: 13772897.9703, N: 13772897.97
- GRID E: 2209274.3663, E: 2203274.36

BM #1947 MAG NAIL WITH WASHER SET IN CONCRETE & BRASS RIGHT-OF-WAY MONUMENT NEAR THE CENTER OF THE NORTHWEST SIDE OF THE SURVEYED TRACT

- ELEV = 828.45'
- GRID N: 1372275.2047, N: 1372275.2
- GRID E: 2202615.3898, E: 2202615.39

**CAUTION!!**  
 EXISTING UNDERGROUND UTILITIES IN THE AREA CONTRACTOR IS RESPONSIBLE FOR DETERMINING THE HORIZONTAL AND VERTICAL LOCATION OF ALL UTILITIES PRIOR TO CONSTRUCTION. CONTRACTOR SHALL BE RESPONSIBLE FOR ANY REPAIRS TO EXISTING UTILITIES DUE TO DAMAGE INCURRED DURING CONSTRUCTION. CONTRACTOR SHALL NOTIFY THE ENGINEER OF ANY DISCREPANCIES ON THE PLANS.

**Kimley-Horn**  
 © 2025 KIMLEY-HORN AND ASSOCIATES, INC.  
 10101 REUNION PLACE, SUITE 400, SAN ANTONIO, TX 78216  
 WWW.KIMLEY-HORN.COM TBE FIRM NO. 928

**FOR REVIEW ONLY**

KHA PROJECT 047096456  
 DATE 5/27/2025  
 SCALE AS SHOWN  
 DESIGNED BY OWNP  
 DRAWN BY OWP  
 CHECKED BY AEN

**THE HOME DEPOT SITE PLAN (LOT 17)**

SCHERTZ STATION SUBDIVISION  
 LOT 10A, BLOCK 1  
 PREPARED FOR  
 THE HOME DEPOT

SCHERTZ, TEXAS  
 18541 RIPPS-KREUSLER RD.

SHEET NUMBER  
**SPC1.0**

**ORDINANCE 25-S-024**

**AN ORDINANCE BY THE CITY COUNCIL OF THE CITY OF SCHERTZ, TEXAS TO AMEND PART III, SCHERTZ CODE OF ORDINANCES, THE UNIFIED DEVELOPMENT CODE (UDC) ARTICLE 11 - SIGN AND ADVERTISING DEVICES, ARTICLE 3 BOARDS, COMMISSIONS, AND COMMITTEES - SECTION 21.3.3 - PLANNING AND ZONING COMMISSION, ARTICLE 7 - NONCONFORMING USES, LOTS, AND STRUCTURES, AND ARTICLE 16 – DEFINITIONS**

**WHEREAS**, pursuant to Ordinance No. 10-S-06, the City of Schertz (the “City”) adopted and Amended and Restated Unified Development Code on April 13, 2010, as further amended (the “Current UDC”); and

**WHEREAS**, City Staff has reviewed the Current UDC and have recommended certain revision and updates to, and reorganization of, the Current UDC;

**WHEREAS**, on May 7, 2025, the Planning and Zoning Commission conducted a public hearing and thereafter recommended approval with modifications; and

**WHEREAS**, on June 17, 2025, the City Council conducted a public hearing and after considering the Criteria and recommendation by the Planning and Zoning Commission, determined that the proposed amendments are appropriate and in the interest of the public safety, health, and welfare.

**BE IT ORDAINED BY THE CITY COUNCIL OF THE CITY OF SCHERTZ, TEXAS: THAT:**

Section 1. The current UDC is hereby amended as set forth on Exhibit A, Exhibit B, Exhibit C, and Exhibit D hereto.

Section 2. The recitals contained in the preamble hereof are hereby found to be true, and such recitals are hereby made a part of this Ordinance for all purposes and are adopted as a part of the judgment and findings of the Council.

Section 3. All ordinances and codes, or parts thereof, which are in conflict or inconsistent with any provision of this Ordinance are hereby repealed to the extent of such conflict, and the provisions of this Ordinance shall be and remain controlling as to the matters resolved herein.

Section 4. This Ordinance shall be construed and enforced in accordance with the laws of the State of Texas and the United States of America.

Section 5. If any provision of this Ordinance or the application thereof to any person or circumstance shall be held to be invalid, the remainder of this Ordinance and the application of such provision to other persons and circumstances shall nevertheless be valid, and the City hereby declares that this Ordinance would have been enacted without such invalid provision.

Section 6. It is officially found, determined, and declared that the meeting at which this Ordinance is adopted was open to the public and public notice of the time, place, and subject matter of the public business to be considered at such meeting, including this Ordinance, was given, all as required by Chapter 551, as amended, Texas Government Code.

Section 7. This Ordinance shall be effective upon the date of final adoption hereof and any publication required by law.

PASSED and ADOPTED, this \_\_\_\_ day of \_\_\_\_\_ 2025.

CITY OF SCHERTZ, TEXAS

---

Ralph Gutierrez, Mayor

ATTEST:

---

Sheila Edmondson, City Secretary

Exhibit "A"

Proposed Unified Development Code (UDC) Amendments

Article 3 – Boards, Commissions, and Committees

Section 21.3.3 – Planning and Zoning Commission

---

### Sec. 21.3.3. Planning and Zoning Commission.

- A. *Structure of the Commission.* The Planning and Zoning Commission is established in accordance with the City Charter and Commission members are appointed by the City Council.
- B. *Duties and Approval Authority.*
1. The Planning and Zoning Commission shall have the authority to review and make a recommendation to the City Council on the following applications:
    - a. amendment to the Comprehensive Land Plan;
    - b. establish or amend a zoning district map classification, including creation or amendment of an overlay district;
    - c. rezoning requests including an application for a Specific Use Permit.
    - d. amendment to the UDC; and
    - e. a Development Agreement as set forth in the LGC and this UDC;
  2. The Planning and Zoning Commission shall have final approval authority on the following applications:
    - a. Subdivision Master Plan, if forwarded by the City Manager or his/her designee.
    - b. Site Plan; if forwarded by the City Manager or his/her designee.
    - c. preliminary plat; if forwarded by the City Manager or his/her designee.
    - d. final plat; if forwarded by the City Manager or his/her designee.
    - e. amending plat; if forwarded by the City Manager or his/her designee.
    - f. minor plat; if forwarded by the City Manager or his/her designee.
    - g. replat; if forwarded by the City Manager or his/her designee.
    - h. waivers relating to Article 11, Signs and Advertising Devices, and
    - i. waivers relating to Article 12, Subdivisions.
  3. The Planning and Zoning Commission shall have the authority to make final determinations relating to appeals of staff determinations on the following items:
    - a. Required Conditions for Home Occupations and denial of a Home Occupation permit.
    - b. Site Design Standards including Tree Preservation & Mitigation, Revisions to Approved Site Plans.
    - c. Signs & Advertising Devices including general requirements, removal of signs.
    - d. Additional Design Requirements including off street parking, building setback lines, and landscape buffers.
    - e. An appeal of a driveway waiver determination.

(Ord. No. 17-S-40, § 1(Exh. A), 10-24-2017; Ord. No. 19-S-22, § 1(Exh. A), 9-3-2019; Ord. No. 23-S-29, § 1(Exh. A), 12-5-2023)

Exhibit "B"

Proposed Unified Development Code (UDC) Amendments

Article 7 - Nonconforming Uses, Lots, and Structure

## ARTICLE 7. NONCONFORMING USES, LOTS AND STRUCTURES

### Sec. 21.7.1. Purpose and intent.

- A. Within the districts established by this UDC or amendments thereto, there may exist lots, structures, uses of land and structures, and characteristics of use which were lawfully in existence and operating before this UDC was enacted, amended or otherwise made applicable to such lots, structures or uses, but which do not now conform to the regulations of the district in which they are located. It is the intent of this UDC to permit such nonconforming uses to continue, as long as the conditions within this section and other applicable sections of this UDC are met.
- B. It is further the intent of this UDC that nonconforming uses, lots and structures shall not be enlarged upon, expanded or extended, and shall not be used as a basis for adding other structures or uses prohibited elsewhere in the same district.
- C. Nonconforming uses are hereby declared to be incompatible with the permitted uses in the districts involved.

(Ord. No. 24-S-20, § 1(Exh. A), 6-18-2024)

### Sec. 21.7.2. Nonconforming status.

- A. Except as provided in section 21.7.9 below, any use, platted lot or structure that does not conform with the regulations of this UDC on the effective date hereof or any amendment hereto, shall be deemed a nonconforming use, platted lot or structure provided that:
  - 1. Such use, platted lot or structure was in existence under, and in compliance with, the provisions of the immediately prior UDC or code;
  - 2. Such use, platted lot or structure was a lawful, nonconforming use, platted lot or structure under the immediately prior UDC or code; or
  - 3. Such use, platted lot or structure was in existence at the time of annexation into the City, was a legal use of the land at such time, and has been in regular and continuous use since such time.
- B. Except as provided in section 21.7.9 below, any other use, platted lot or structure which does not conform with the regulations of the zoning district in which it is located on the effective date of this UDC or any amendment hereto, shall be deemed to be in violation of this UDC, and the City shall be entitled to enforce fully the terms of this UDC with respect to such use, platted lot or structure.

(Ord. No. 24-S-20, § 1(Exh. A), 6-18-2024)

### Sec. 21.7.3. Continuing lawful use of land and structures.

- A. A nonconforming use or structure may continue to be used, operated or occupied in accordance with the terms of the zoning regulations by which it was established, or in the case of annexed property, in accordance with the regulations under which it was created.
- B. A nonconforming structure occupied by a nonconforming use may be re-occupied by a conforming use, following abandonment of the nonconforming use.

---

(Ord. No. 24-S-20, § 1(Exh. A), 6-18-2024)

**Sec. 21.7.4. Expansion of nonconforming uses and structures.**

- A. A nonconforming use may be extended throughout the structure in which it is located, provided that:
  - 1. The structure or its premises shall not be enlarged or increased in height, in floor area or in land area to accommodate extension of the nonconforming use;
  - 2. No alteration shall be made to the structure occupied by the nonconforming use, except those alterations that are required by law to preserve the integrity of the structure and alterations that would upgrade the quality, safety or aesthetic appeal of the structure; and
  - 3. The number of dwelling units occupying the structure shall not exceed the number of dwelling units existing at the time the use became nonconforming.
- B. A nonconforming use occupying a structure shall not be extended to occupy land outside the structure.
- C. A nonconforming use or structure shall not be enlarged, increased or extended to occupy a greater area of land than was occupied at the time the use or structure became nonconforming, except to provide additional off-street parking or loading areas required by this UDC.

(Ord. No. 24-S-20, § 1(Exh. A), 6-18-2024)

**Sec. 21.7.5. Abandonment of nonconforming uses and structures, and cessation of use of structures or land.**

- A. If a nonconforming use or structure is abandoned, any future use of the premises shall be in conformity with the provisions of this UDC, as amended, and with any other applicable City codes, ordinances or regulations that are in effect at the time the use is resumed or the structure is re-occupied.
- B. A nonconforming use or structure shall be deemed "abandoned" in the following circumstances:
  - 1. The use ceases to operate for a continuous period of 180 calendar days;
  - 2. The structure remains vacant for a continuous period of 180 calendar days; or
  - 3. In the case of a temporary use, the use is moved from the premises for any length of time.
- C. If the use of any lot, tract or property that does not have a building on it and that is used for open/outside storage as of the effective date of this UDC is made nonconforming by this UDC, as amended on the effective date, then such storage use shall cease within 180 calendar days following the effective date of this UDC. The lot, tract or property shall be cleaned up and all trash, debris, stored items and vehicles, and other materials shall be removed from the premises such that the property is not a physical or visual nuisance to the public or to surrounding property owners.

(Ord. No. 24-S-20, § 1(Exh. A), 6-18-2024)

**Sec. 21.7.6. Substitution of nonconforming uses.**

- A. A nonconforming use shall not be changed to another nonconforming use.
- B. A nonconforming use may be changed to a conforming use provided that, once such change is made, the use shall not be changed back to a nonconforming use.

---

(Supp. No. 9)

Created: 2024-11-27 10:11:33 [EST]

- C. A conforming use located in a nonconforming structure may be changed to another conforming use, but shall not be changed to another nonconforming use.
- D. Notwithstanding any of the provisions of this section, a nonconforming HUD-Code manufactured home may be exchanged or replaced by another HUD-Code manufactured home, provided the newly located residential unit is owner-occupied.

(Ord. No. 24-S-20, § 1(Exh. A), 6-18-2024)

**Sec. 21.7.7. Reconstruction or repair of nonconforming structure.**

- A. If more than fifty percent (50%) of the total appraised value of a nonconforming structure, as determined by the applicable county appraisal district, is destroyed by fire, the elements, or some other cause, then the structure may be rebuilt only in conformity with the standards of this UDC.
- B. If less than fifty percent (50%) of the total appraised value of a nonconforming structure, as determined by the applicable county appraisal district, is destroyed by fire, the elements, or some other cause, then the structure may be reconstructed as it was before the partial destruction but only to its original dimensions and floor area, and provided that such reconstruction is completed within 365 calendar days following the event that caused the partial destruction. If reconstruction is delayed by contested insurance claims, litigation, or some other similar cause, then the 365 calendar day reconstruction period may be extended by the City Manager or his/her designee, at his/her sole discretion.
- C. If a nonconforming structure that is totally or partially destroyed was occupied by a nonconforming use at the time of such destruction, then the nonconforming use may be re-established subject to the limitations on expansion set forth in section 21.7.4 above.
- D. Any conforming structure that is totally or partially destroyed shall be reconstructed only in conformity with the standards of this UDC.
- E. Nothing in this UDC shall be construed to prohibit the upgrading, strengthening, repair or maintenance of any part of any structure, conforming or nonconforming, that is declared unsafe or uninhabitable by the proper authority, unless such repairs or maintenance exceeds fifty percent (50%) of the structure's appraised value, as determined by the applicable county appraisal district.

(Ord. No. 24-S-20, § 1(Exh. A), 6-18-2024)

**Sec. 21.7.8. Relocation of nonconforming structure.**

No nonconforming structure or building shall be moved in whole or in part to any other location on the lot, or to any other location or lot, unless every portion of such structure is in compliance with all the regulations of the zoning district in which the structure is to be relocated. Such building relocation shall also require a structure relocation permit from the City, and may also require platting of the intended building site as well as Site Plan approval pursuant to this UDC.

(Ord. No. 24-S-20, § 1(Exh. A), 6-18-2024)

**Sec. 21.7.9. Nonconforming lots.**

- A. The following types of platted lots shall be deemed in conformance with the provisions of this UDC, notwithstanding the fact that such lot does not meet the standards of this UDC in the zoning district in which it is located:

1. Any vacant lot that conformed to the City's zoning district regulations at the time that it was platted; or
  2. Any lot occupied by a single-family dwelling authorized under the zoning district regulations in which the lot is located.
- B. Nothing in this UDC shall be construed to prohibit the use of a lot that does not meet the minimum lot standards of the zoning district in which it is located, provided that the lot is zoned for the land use(s) intended and the lot was platted as a lot of record prior to the effective date of this UDC.
- C. A lot of record located within the RA zoning district that is nonconforming may be occupied by a single-family dwelling provided that all applicable zoning standards with regard to building setbacks, building size and design criteria are met.

(Ord. No. 24-S-20, § 1(Exh. A), 6-18-2024)

### **Sec. 21.7.10. Validation.**

- A. Within the City, there exist on the following subdivisions: Belmont Park; Kramer Farm; Whisper Meadows; Northcliffe II; Tanglewood; Wynn Brook; Jonas Woods Unit 1 Lots 1-18, Block 3; Jonas Woods Unit 1 Lots 1-29, Block 2; Jonas Woods Unit 1 Lots 1-18 and 51-65, Block 1; Jonas Woods Unit 4; The Ridge at Scenic Hills; Fairhaven; The Links at Scenic Hills; and The Fairways at Scenic Hills (the "Subdivisions"), which include structural encroachments onto platted setbacks; plats with improperly designated setbacks or improper lot sizes; and improper master plans. It is the intent of this section to validate such improper encroachments, plats, and master plans in the subdivisions and to determine that such improper encroachments, plats, and master plans are deemed not to be in violation of this UDC, but only so long as the conditions within this section 21.7.10 of this UDC are met. The provisions of this section shall be limited to validate only the improper encroachments, plats, and master plans on February 24, 2009 in the subdivisions.
- B. The portions of existing structures encroaching onto platted setbacks in any of the subdivisions on the effective date of this UDC (validated encroaching structures) shall not be enlarged upon, expanded, or extended into the platted setback area.
- C. If more than fifty percent (50%) of (i) the total square footage of a validated encroaching structure or (ii) the total appraised value of the validated encroaching structure, as determined by the applicable county appraisal district, is destroyed by fire, the elements, or some other cause, the validated encroaching structure may not be rebuilt within the platted setback, except as may otherwise be permitted by this UDC (other than this section). If fifty percent (50%) or less of (i) the total square footage of a validated encroaching structure or (ii) the total appraised value of the validated encroaching structure, as determined by the applicable county appraisal district, is destroyed by fire, the elements, or some other cause, the validated encroaching structure may be reconstructed as it was before the partial destruction but only to its original dimensions and footprint area within the platted setback, and provided that such reconstruction is completed within 365 calendar days following the event that caused the partial destruction. If reconstruction is delayed by contested insurance claims, litigation, or some other similar cause, the three hundred sixty-five calendar day reconstruction period may be extended by the City Manager or his/her designee, at his/her sole discretion.
- D. No validated encroaching structure encroaching onto a platted setback shall be moved in whole or in part to any other location on the lot, unless every portion of such structure after such relocation is out of the platted setback and is in compliance with all the requirements of the zoning district for such lot and all other applicable requirements of this UDC and other applicable codes, ordinances or regulations of the City in effect at such time.
- E. If application is made to have plats with improper setbacks, plats with improper lot sizes, and/or existing master plans for any of the subdivisions replatted or amended, any such replats or amendments shall be

---

required to be in conformity with the provisions of this UDC (other than this section) and with all other applicable City codes, ordinances or regulations that are in effect at the time application for amendment or replatting is made.

- F. This section is subject in all events to the property owner's rights set forth in Local Government Code Chapter 245.

(Ord. No. 24-S-20, § 1(Exh. A), 6-18-2024)

### **Sec. 21.7.11 Agricultural Operations.**

- A. Within the City of Schertz, there exists properties that have been utilized for Agricultural Operations prior to being annexed into the City of Schertz. Agricultural Operations per H.B. No 1750 include cultivating the soil, producing crops or growing vegetation for human food, animal feed, livestock forage, forage for wildlife management, planting seed or fiber, floriculture, viticulture, horticulture, silviculture, wildlife management, raising or keeping livestock or poultry, including veterinary services, and planting cover crops or leaving land idle for the purpose of participating in any governmental program or normal crop of livestock rotation procedures. Per Texas Agriculture Code Chapter 251 Section 251.0055 a city may not impose a governmental requirement that directly or indirectly prohibits the use of a generally accepted agricultural practice.
- B. In order to ensure that properties within the City of Schertz that have been utilized for Agricultural Operations can continue the following are applicable:
- a. Land Use: Properties can be utilized for Agricultural Operations including alternating between growing crops and raising livestock regardless of the zoning designation for the property.
  - b. Expansion of Agricultural Operations: Existing Agricultural Operations can expand to include:
    - i. Increase of field crop area or increase of livestock or change in livestock species
    - ii. Construction of Maintenance Buildings or Equipment Sheds, Barns, Accessory Buildings, Animal Cages or Corrals, Feeders or Grain Storage, or any other miscellaneous Agricultural related structure.
      1. Issuance of building permits will not be required for any Maintenance Buildings or Equipment Sheds, Barns, Accessory Buildings, Animal Cages or Corrals, Feeders or Grain Storage, or any other miscellaneous Agricultural related structure that is less than 2,000 square feet.
      2. Platting of the property and connection to sanitary sewer will not be required for construction of Maintenance Buildings or Equipment Sheds, Barns, Accessory Buildings, Animal Cages or Corrals, Feeders or Grain Storage, or any other miscellaneous Agricultural related structure.
      3. This does not negate the requirement to obtain any necessary building permits or any Certificate of Occupancy requirements for a commercial business that will be occupied by or serves those that do not own or work for the agricultural operation.
    - iii. Construction of additional single family detached residential dwelling units which shall only be utilized for family members or employees of the Agricultural Operations on the same property with a minimum of 5 acres per unit, up to an additional four (4) units per property.
      1. Issuance of building permits will be required for any additional single family detached residential dwelling units.
      2. Platting of the property and connection to sanitary sewer will not be required for construction of additional single family detached residential dwelling units.

- iv. Construction of new, or repair of existing agricultural fencing in conjunction with agricultural operations, including utilizing barbed wire, is permitted without obtaining a building permit as long as the proposed fencing is within the property boundaries and does not impede sight visibility.
- c. Development Process: Agricultural Operations are subject to all City of Schertz development regulations and processes to include but not limited to Platting, Site Plan, and Building Permits and Inspections with the exceptions provided within this section.

(Ord. No. 24-S-20, § 1(Exh. A), 6-18-2024)

**Sec. 21.7.12 Nonconforming Signs.**

- A. *General.* A sign, including its supporting structure, shall be considered nonconforming when it does not conform to all or part of the provisions of this Article and
  - 1. was in existence and lawfully located and used in accordance with the provisions of the prior law, ordinance, code or regulation applicable thereto or which was considered legally nonconforming there under and has since been in continuous or regular use;
  - 2. was in existence, located and used on the premises at the time it was annexed into the City and has since been in continuous use; or
  - 3. was in existence and lawfully located and used as an off-premise sign prior to or on February 19, 2008.
- B. Signs shall lose nonconforming status when:
  - 1. it is removed from the premises for any reason;
  - 2. it has been blown down or otherwise destroyed or dismantled for any purpose other than maintenance operations or for changing the letters, symbols, or other matter on the sign;
    - a. a sign or substantial part of it is considered to have been destroyed only if the cost of repairing the sign is more than 60 percent of the cost of erecting a new sign of the same type at the same location
  - 3. it has become an abandoned sign, a sign that no longer serves to direct attention to an event, person, product, good, service, or activity, which is no longer conducted; or
  - 4. any structural changes are made not related to repair.

Exhibit "C"

Proposed Unified Development Code (UDC) Amendments

Article 11 - Sign and Advertising Devices

## ARTICLE 11. SIGNS AND ADVERTISING DEVICES

### Sec. 21.11.1. Purpose.

The City recognizes the safety, commercial, emergency, and informational needs for signs. This Article has been adopted to protect the health, safety, and welfare of the citizens in accordance with LGC Chapter 216. The City Manager or his/her designee is hereby authorized and directed to enforce and interpret the provisions of this Article and other laws, ordinances, codes and regulations applicable thereto in the City.

### Sec. 21.11.2. Applicability.

All signs shall be erected, displayed, altered or reconstructed in conformity with this Article. Where there is a conflict between a general requirement and a specific requirement, the specific requirement shall be applicable.

### Sec. 21.11.3. Administration.

- A. *Applications.* The City Manager or his/her designee shall receive applications, review plans and documentation and issue permits for the erection, installation, enlargement, alteration, and repair of all signs within the City and its ETJ.
- B. *Inspection.* The City Manager or his/her designee shall make all inspections necessary to ensure compliance with all state and local requirements governing signage.
- C. *Notices and Orders.* The City Manager or his/her designee shall issue all necessary citations, notices or orders to ensure compliance with this Article.
- D. *Liability.* The City Manager or his/her designee, members of the Planning and Zoning Commission, or other City employees charged with the enforcement of this Article, while acting for the City in good faith and without malice in the discharge of the duties required by this Article or other pertinent laws, ordinances, codes or regulations shall not be rendered liable personally and are hereby relieved of personal liability for any damage accruing to persons or property as a result of any act or by reason of an act or omission in the discharge of official duties. Any suit instituted against an officer or employee because of an act performed by that officer or employee in the lawful discharge of duties and under the provisions of this Article shall be defended by a legal representative of the City until the final termination of the proceedings.

### Sec. 21.11.4. General Requirements.

- A. *Permit Required.*
  1. No person shall erect, alter or display any sign without first obtaining a sign permit to do so from the City Manager or his/her designee. No sign permit shall be released by the City Manager or his/her designee until after the building permit for the principal building on the site has been issued.
  2. *Electrical Permit Required.* No person shall install and connect electrical systems for a sign within the City or its ETJ without first obtaining an electrical permit from the City Manager or his/her designee. The the City Manager or his/her designee shall not issue an electrical permit for a sign until after the principal sign permit for such work has been issued.
- B. *Application.* The following information shall be required for each application for a permit:
  1. Completed building permit application;

- 
2. Sign Plan Exhibits which include:
    - a. location of all buildings, structures or tracts to which or upon which the sign is to be attached or erected; and
    - b. position of the sign in relation to rights-of-way, property lines, easements, buildings or structures and other existing signs; and
    - c. plans that illustrate height, length, width and all other dimensions associated with the sign including all electrical elements of the sign.
  3. A copy of a contract with construction costs signed by the owner of the property stating that the applicant has permission to erect such sign.
- C. *Fees.* All fees for a sign permit shall be in accordance with the current fee schedule adopted by City Council.
1. A permit shall not be valid until such fee has been paid. An amendment to a permit shall not be released until the additional fees, if any, have been paid.
  2. An additional fee shall be assessed in accordance with the current fee schedule for work beginning prior to obtaining a permit as required by this Article. Payment of such fees shall not relieve any person(s) from any other penalties prescribed by this UDC or any other law, ordinance, code or regulation applicable thereto.
- D. *Action on Application.* The City Manager or his/her designee shall examine applications for permits and amendments in accordance with state law after a complete application is filed. If the application or the construction documents do not conform to the requirements of this Article and other pertinent laws, ordinances, codes or regulations, the City Manager or his/her designee shall reject such application in writing, stating the reasons therefore. If the City Manager or his/her designee is satisfied that the proposed work conforms to the requirements of this Article and other laws, ordinances, codes and regulations applicable thereto, the City Manager or his/her designee shall issue a permit.
- E. *Time Limitation of Application.* An application for a permit for any proposed work for which a permit has not been issued shall be deemed abandoned six (6) months after the date of filing. The City Manager or his/her designee may, at his/her discretion, grant one extension for additional time not exceeding ninety (90) days. The extension shall be requested in writing and justifiable cause demonstrated. Permits issued under this Article are non-transferable from one person to another.
- F. *Condition of Permit.* A permit issued under this Article shall be construed to be a license to proceed with the work and not as authority to violate, cancel, alter, or set aside any of the provisions of this Article or other law, ordinances, codes and regulations applicable thereto. Nor shall issuance of a permit prevent the City Manager or his/her designee from thereafter requiring correction of errors in plans, construction, or removing violations of this Article or other laws, ordinances, codes or regulations applicable thereto. Every permit issued shall become invalid six (6) months after its issuance if the work is not completed unless otherwise stated in this Article.
- G. *Suspension or Revocation.* The City Manager or his/her designee is authorized to suspend or revoke a permit issued under this Article whenever the permit is issued in error or on the basis of incorrect, inaccurate or incomplete information, or in violation of this Article or any other laws, ordinances, codes or regulations applicable thereto.
- H. *Public Rights-of-Way, Alleys and Easements.* A permit shall not be issued by the City Manager or his/her designee for the placement of a sign that will encroach upon any public right-of-way, alley or utility or drainage easement.
- I. *Placement of Permit.* The permit or copy thereof shall be kept on the site until the work permitted is completed.

- J. *Appeal*. An individual who has been denied a permit or had a permit revoked may appeal in writing along with the established filing fee to the Planning and Zoning Commission within ten (10) days after the date of denial or revocation.

### Sec. 21.11.5. Exempted Signs.

The following types of signs or sign work are exempt from the permit requirements of this Article provided exemptions does not violate any other provisions of this Article or this UDC:

- A. *Governmental Signs*. Any sign indicating public facilities, public works projects, public services, or other places, events, persons, products, goods, programs, activities or institutions conducted by the Federal, State or any local government.
- B. *Political Signs*. A sign pertaining to any national, state, county or local election, or issue and erected for the purpose of announcing a political candidate, political party or ballot measure, or a position on a political issue.
- C. *Railway Signs*. Any sign within the railway right-of-way placed and maintained in reference to the operation of such railway.
- D. *Utility Signs*. Any sign marking utility or underground communications or transmission lines.
- E. *Vehicle Signs*. Any sign placed on or affixed to vehicles and/or trailers where the sign is incidental to the primary use of the vehicle or trailer as a form of transportation and which identifies the business, products, or services with which the vehicle and/or trailer is related.
- F. *Flags*. Official flags of governmental jurisdictions or non-profit organizations. Nothing in this Article shall be construed to prevent the display of a national or state flag or to limit flags, insignias, or legal notices or informational, directional or traffic signs which are legally required and necessary to the essential functions of governmental agencies. Flag poles shall not exceed thirty-five (35) feet in height.
- G. *Warning Signs*. Signs warning the public of the existence of danger but containing no advertising material.
- H. *Street Address Signs*. Address signs containing only numeric addresses and street names.
- I. *Holiday Signs*. Any temporary sign promoting the celebration of a holiday and containing no commercial advertising.
- J. *Plaques*. Any commemorative sign of a recognized historical society or organization.
- K. *Menu Board Signs*. A maximum of two (2) menu board signs, each with a maximum of thirty-two (32) square feet in area, shall be allowed per drive through service restaurant or restaurant drive-up window or similar drive through business. Structural and electrical elements will still require review from the City Manager or his/her designee.
- L. *Minor Repairs and Maintenance*. Minor repair work to any sign, including the replacement of lamps or the connection of approved portable electrical equipment to approved permanently installed receptacles, painting or other similar exterior maintenance of a sign structure so long as no structural alterations are made to the sign.
- M. *Murals*. A graphic displayed on the exterior of a building for decoration or artistic expression. Shall not include text, logos, or images advertising or indicating a service or product.
- N. *Directional Signs*: Any on-premise sign that directs the movement of traffic on private property within developments. Directional signs shall be located in a manner where they will not interfere with the safe movement of vehicles or pedestrians and shall not be located within any visibility triangle. Cannot be greater than twelve (12) square feet in area.

---

**Sec. 21.11.6. Prohibited Signs.**

- A. *Obscene Signs.* No person shall erect or display a sign in which the dominant theme of material taken as a whole appeals to the prurient interest in sex, and is patently offensive because it affronts current community standards relating to the description or representation of sexual matters, and is utterly without redeeming social literary, artistic, political, and scientific value, according to contemporary community standards.
- B. *Obstructing Doors, Windows or Fire Escapes.* No person shall erect or display any sign that prevents free ingress to or egress from any door, window or fire escape.
- C. *Obstructing Vision/Sight Triangle.* No person shall erect or display any sign in such a manner as to obstruct free and clear vision of moving vehicles at any location, street intersection, or driveway. All signs placed at any intersection shall prevent such problem by observing a visibility triangle (see definition of visibility triangle).
- D. *Interference With Traffic.* No sign shall be permitted which interferes with vehicular or pedestrian traffic as a result of the position, size, shape, movement, color, fashion, manner, or intensity of illumination, or any other characteristics causing such interference. No person shall erect or allow to be displayed any sign in such a manner as to interfere with, obstruct the view of, or be confused with any authorized traffic sign, signal, or device, including, signs making use of the words "stop", "go", "look", "slow", "danger", or any other similar word, phrase, symbol or character. No person shall employ any red, yellow, green, or other colored lamp or light in such a manner as to cause confusion or otherwise interfere with vehicular or pedestrian traffic.
- E. *Over Public Property or Public Right-of-Way.* It shall be prohibited to erect or display any type of sign on or over public ROW or other public property, unless the same is erected by the City, County, State or other authorized governmental agency, or with the permission of the City (in its sole discretion), for public purposes.
- F. *Signs on Utility Poles.* No person shall erect or display any sign except as specifically authorized by section 21.11.5 on any utility pole located upon any public right-of-way or utility easement.
- G. *Private Property.* No sign shall be located on private property without the consent of the owner of the premises, including signs located on trees, light poles or mail boxes.
- H. *Dilapidated Signs.* No sign shall be allowed which is deteriorated, dilapidated or in danger of falling or otherwise unsafe.
- I. *Signs in Violation.* No sign shall be allowed that does not comply with any applicable provisions of the building code, this UDC, or any other applicable laws, ordinances, codes or regulations of the City.
- J. *Home Occupation Signs.* No exterior home occupation signs shall be permitted.
- K. *Off Premise Signs.* Except as set forth elsewhere in this Article, all off premise signs are prohibited except that the following signs may be permitted provided they otherwise meet the applicable requirements of this Article:
  - 1. Community Service Signs;
  - 2. Garage Sale Signs;
  - 3. Official Government Signs;
  - 4. Historical Markers and Plaques;
  - 5. Political Signs;
  - 6. Real Estate Signs;

- 
- 7. Temporary Signs;
  - 8. Traffic Signs;
  - L. *Bandit Signs.*
  - M. *Painted Signs.* No sign advertising or indicating a service or product with text, logos, or images shall be permitted which is painted on the wall of any building or on any part of a building.
  - N. Balloon Signs including inflatable signs are prohibited regardless of size. Feather Flags are the only type of wind driven signs allowed.
  - O. *Other Signs.* Except as set forth elsewhere in this Article, any signs not specifically permitted by this Article are prohibited within the City.

**Sec. 21.11.7. Removal of Signs.**

- A. *Damaged Signs.* Signs which are determined by the City Manager or his/her designee to be a public hazard or in a state of disrepair shall be repaired or removed within ten (10) days after written notification to the property owner.
- B. *Abandoned Signs.* Signs which are determined by the City Manager or his/her designee to be abandoned shall be removed or otherwise painted over within thirty (30) days after written notification to the property owner by the City Manager or his/her designee.
- C. *Extensions.* The City Manager or his/her designee shall have the authority, to grant extensions as necessary to resolve a damaged or abandoned sign. The extension shall be requested in writing and justifiable cause demonstrated.
- D. *Signs in Right-of-Way and/or Public Property.* Any sign that is erected, constructed, or otherwise located within or upon public right-of-way or on public property may be removed by City personnel and disposed of immediately. The City is not required to notify the owner of the sign of its removal and disposal.
- E. *Relocation of Certain Detached On-Premise Signs.*
  - 1. Legal and non-conforming detached on-premise signs located on or overhanging a parcel of land acquired by a governmental entity may be relocated subject to the restrictions in this section. The owner of the sign and the governmental entity must sign an application requesting the relocation. The relocation must be completed within one (1) year after the date the governmental entity becomes the owner of the property. All relocated signs must fully comply with spacing, setbacks, and other restrictions in this section. All signs must relocate on the remainder of the tract from which the parcel of land was acquired unless:
    - a. There is no remainder; or
    - b. The remainder is not of sufficient size or suitable configuration to allow the relocated sign to fully comply with the spacing, setback, and other restrictions in this section.
  - 2. No relocated detached on-premise sign may have a greater effective area or increased height than it had at its original location, or contain new materials that are more than five feet (5') above grade.
  - 3. No detached on-premise sign may be relocated until demolition and other required permits have been applied for and approved by the City.
  - 4. No new electrical or mechanical properties may be added to a relocated detached on-premise sign. (For example, a non-illuminated sign may not be converted to an illuminated sign.)

- 
- F. *Illegally Erected Temporary Sign.* Any temporary sign that is erected, constructed or otherwise displayed, without a permit or in direct violation of this Article shall be removed by City personnel and disposed of immediately. The City is not required to notify the owner of the sign of its removal and disposal.
  - G. *Illegally Erected Permanent Sign.* Any permanent sign installed without a permit or in direct violation of this Article shall be removed by the owner of the sign or property within ten (10) days after written notification by the City Manager or his/her designee.
  - H. *Filing of Liens Against the Property.* The City is authorized to file a lien against any property which is not otherwise exempt to recover reasonable expenses incurred by the City for the removal of a sign or portion of a sign.
  - I. *Appeal.* Any decision rendered by the City Manager or his/her designee or other City personnel in the enforcement of this Article may be appealed to the Planning and Zoning Commission by any person, agent, or representative affected by such decision. Such appeal must be in writing and received within ten (10) days after a decision rendered along with the established fee.

### **Sec. 21.11.8. General Sign Provisions.**

The provisions of this section shall be applicable to all signs hereafter erected, constructed, displayed, altered or repaired on any premise under the jurisdiction of the City.

- A. *Height of Signs.* The vertical height of a sign shall be measured from ground level to the highest part of the sign or its structure.
- B. *Wind and Dead Load Requirements.* All signs shall be designed and constructed to withstand wind loads and to receive dead loads as required by building codes adopted by the City. The sign application must include a statement signed or a letter with an engineer's seal that states compliance with this requirement.
- C. *Location of Business/Residential.* All business and residential locations shall be identified by an address, which is clearly visible from the street.
- D. *Illumination of Signs.* No sign shall be illuminated to such intensity to exceed a maximum of one (1) footcandle measured at the property line. No lighted sign shall be erected or displayed within 150 feet of a single-family residential zoned property unless the lighting is shielded from view.
- E. *Building and Electrical Codes Applicable.* All signs shall be constructed and maintained in conformity with all applicable provisions of the building code, electrical code or other applicable laws, ordinances, codes or regulations of the City.
- F. *Maintenance of Signs.* Every sign shall be maintained in good structural condition at all times. All signs shall be kept neatly painted including all metal parts and supports that are not galvanized or of rust resistant material. On undeveloped parcels of land, the area between any sign and the street or highway to which the sign is oriented and the area within twenty-five feet (25') of such sign must be kept free and clear of debris, trash, and weeds or other refuse and shall be maintained by mowing or trimming of any vegetation.
- G. *Structural Sign Elements.* The structural elements of permanent signs shall be constructed of materials that are noncombustible and may be supported by noncombustible materials only and finished in a presentable manner. Wood or unpainted steel supports are prohibited. Heavy timber and other materials may be used only if approved by the City Manager or his/her designee.
- H. *Sign Clearance.* Notwithstanding any other provisions of this UDC, all signs shall maintain a clearance of at least ten feet (10') when located over a public sidewalk and at least fourteen feet (14') when located over a driveway.

- I. *Sign Area.* The maximum effective sign area shall be the total square footage of a single face specified for each type of sign within this Article.

**Sec. 21.11.9. Wall Signs.**

- A. Wall Sign Standards apply per façade. Wall signs may be one contiguous sign or have multiple separate components provided total allowable square footage is not exceeded.

Wall Sign Standards		
Roadway Classification	Max Area sq. ft.(per facade)	Maximum Number of façades with signage
Interstates & Farm to Market Roads	250	3 per building or tenant
All Others	100	3 per building or tenant

1. Roadway Classification is determined by the address of the building or unit and applies to each allowable sign.
2. Buildings over 100,000 square feet are allowed an additional 100 square feet of maximum signage area.
3. Wall signs shall not extend into the required building setback and may not be attached to light fixtures, poles, or trees.
4. In no case shall a wall sign project above the roofline of any building nor extend above the parapet wall if attached thereto.
5. Wall signs shall not be located on any facade (other than the main front of the building) which faces property zoned for single-family residential uses if the sign is within 150 feet of the property line of said residential property.
6. Properties on Main Street with a facade facing the railroad are allowed 250 square feet of signage facing FM 78.
  - a. Shall not exceed maximum allowable number of facades with signage.

**Sec. 21.11.10. Freestanding Signs.**

- A. Freestanding Sign Standards.

Freestanding Sign Standards				
Roadway Classification	Setback ft.	Max Area sq. ft.	Max Height ft.	Maximum Number
Interstates	15	250	50	1 per lot per frontage
Farm to Market Roads	15	250	35	1 per lot per frontage
All Others	15	150	20	1 per lot per frontage

1. Roadway Classification is determined by the adjacent frontage the sign will be placed.
2. Developments consisting of shopping centers or other multi-tenant type developments shall provide adequate sign spaces for each tenant and no tenant shall have more than 50% of the allowable area.
3. A freestanding sign may include an electronic sign as a component of the permitted sign with the following additional standards:
  - a. Limited to two (2) faces per sign.

- b. Limited to fifty (50) square feet per sign face.
- c. Electronic signage shall not exceed a maximum of one (1) footcandle illumination at the property line.
- d. Any change of pictures or information on the electronic sign shall not produce the illusion of moving objects, expanding or contracting shapes, rotation or any similar effect of animation.
- e. Any change of pictures or information on the message board sign shall not change more often than once every four (4) seconds.
- f. Any sign picture or information shall not have a solid white background between the time period of thirty (30) minutes after sunset and thirty (30) minutes before sunrise.

**Sec. 21.11.11. Price-Per-Gallon Display .**

- A. *General.* All price-per-gallon displays must be an integral part of the freestanding sign or wall sign for the site. Displays, whether electronic or manual, shall not scroll or flash.
- B. *Number of Signs.* Only one (1) price-per-gallon sign shall be permitted per site.
- C. *Illumination.* Only internal illumination may be utilized for fuel classification and price-per-gallon sign.

**Sec. 21.11.12. Subdivision Entry Signs.**

- A. Subdivision Entry Sign Standards

Subdivision Entry Sign Standards			
Roadway Classification	Max Area sq. ft.	Max Height ft.	Maximum Number
Interstates & Farm to Market Roads	50	10	2 per entry
All Others	32	6	2 per entry

- 1. *Subdivision Entry Feature.* A subdivision entry feature which incorporates masonry walls, berms and/or decorative fencing in combination with the subdivision entry sign may be constructed, however, the maximum area containing the subdivision sign shall not exceed standards.

**Sec. 21.11.13. Temporary Signs.**

- A. Temporary Sign Standards.

Temporary Sign Standards			
Setback ft.	Max Area sq. ft.	Max Height ft.	Maximum Number
15	24	6	3 per business or tenant
Feather Flag Standards			
Setback ft.	Max Area sq. ft.	Max Height ft.	Maximum Number
15	16	8	3 per business or tenant

- 1. Temporary signs shall be permitted for a maximum of 120 days per calendar year and Temporary Sign permits will be issued for thirty (30) day increments.

- a. The cumulative total number of days for which all temporary sign permits issued for a property or business shall not exceed 120 calendar days.
  - b. Each individual sign will count towards the allotted 120 calendar days.
  - c. Feather Flags shall only be permitted for 28 days per calendar year.
2. *Recurring Event Permit.* A Recurring Event Permit is for temporary signs that will be issued in two-day increments for up to fifteen (15) times per year. The applicant requesting a Recurring Event Permit must identify which 15 two day increments they intend to have the temporary signs when applying for the initial permit. The selected dates can be modified as dates change with prior approval.
3. Exceptions:
- a. Development signs may be installed at any time after the issuance of the building permit for a commercial development or after approval of the final plat for a residential subdivision. The development sign must be removed within six (6) months or upon the issuance of a certificate of occupancy for commercial developments, and within three (3) years of a residential subdivision.
  - b. Real estate signs shall be exempt from the permitting requirements of this section if they do not exceed six feet (6') in height and do not exceed thirty-two (32) square feet in area. Real estate signs shall be limited to one (1) per lot per street frontage.

#### **Sec. 21.11.14. Banners Over Public Rights-of-Way.**

- A. *General.* Banners may be erected over predetermined public rights-of-way within the City with the approval of the City Manager or his/her designee.
- B. *Restrictions.* Banners over public rights-of-way shall be permitted only for non-commercial or charitable events that are of general interest to the community as a whole and shall be restricted to non-profit or governmental entities.
- C. *Responsibility.* The applicant shall be responsible for the erection of any banner over public rights-of-way. The banner shall be inspected by the City Manager or his/her designee to ensure the banner is adequately secured. The applicant shall be responsible for removal of any banner erected over public rights-of-way.
- D. *Maximum Banner Size.* The maximum area of a banner shall not exceed 144 square feet. The standard banner size shall be four feet (4') wide by thirty-six feet (36') long. Variations to the standard banner size may be approved by the City Manager or his/her designee when differing variations are necessary to contain the entire message within the banner. In no case shall the area exceed the maximum area identified in this section.

#### **Sec. 21.11.15. Waivers**

- A. The Planning and Zoning Commission may authorize waivers from the provisions of this Article when, in its opinion, undue hardship will result from requiring strict compliance. In granting a waiver, the Planning and Zoning Commission shall prescribe only conditions that it deems necessary or desirable to the public interest.
- B. In making their findings, the Planning and Zoning Commission shall take into account the following:
  - a. The nature of the proposed use of the land involved.
  - b. The location of the property in relation to roadway classification.

- 
- c. The existing uses of land in the vicinity.
  - C. Waivers shall not be granted unless the Planning and Zoning Commission finds:
    - 1. That the granting of the waiver will not be detrimental to the public health, safety, or welfare, or injurious to other property in the area; and
    - 2. Strict interpretation of the provisions of the section would deprive the applicant of rights commonly enjoyed by other nearby properties with the same land use that would comply with the same provisions.
  - D. The Planning and Zoning Commission may establish a time period for execution of each granted waiver.
  - E. Such findings together with the specific facts on which such findings are based shall be incorporated into the official minutes of the Planning and Zoning Commission meeting at which such exception is granted.
  - F. Planning and Zoning Commission shall not authorize a waiver that would constitute a violation of a valid law, ordinance, code or regulation of the City.
  - G. Any decision of the Planning and Zoning Commission regarding waivers to the provisions of this Article may be appealed to the City Council. When considering an appeal, the City Council shall consider the same standards as the Planning and Zoning Commission as outlined above.

**Sec. 21.11.16. Violations.**

- A. *Unlawful Acts.* It shall be unlawful for any person, firm or corporation to erect, construct, alter, extend, repair, move, remove, or demolish a sign regulated by this Article, or cause the same to be done in conflict with or in violation of any of the provisions of this Article.
- B. *Notice of Violation.* The City Manager or his/her designee is authorized to serve a notice of violation or order on the person responsible for the erection, construction, alteration, extension, repair, moving, removing or demolition of a sign in violation of the provisions of this Article or in violation of a permit issued under the provisions of this Article. Such order shall direct the discontinuance of the illegal action or condition and the abatement of the violation.

Exhibit “D”

Proposed Unified Development Code (UDC) Amendments

Article 16 – Definitions

**Exhibit "D"**

**Proposed UDC Amendment**

**Article 16 - Definitions**

**Proposed changes to Article 16 - Definitions to add:**

*Façade:* The portion of any exterior elevation of the building extending from grade to the top of the roof or parapet. Does not include structural or nonstructural elements which extend beyond roof or parapet.

*Murals.* A graphic displayed on the exterior of a building for decoration or artistic expression. Shall not include text, logos, or images advertising or indicating a service or product.

*Subdivision Entry Signs:* entry signs identifying a residential or mixed-use development.

**Proposed changes to Article 16 - Definitions to replace/edit:**

*Balloon/Inflatable Signs:* One or more inflatable devices filled with lighter-than-air gas used as a temporary sign for the purpose of directing attention to any location, event, person, product, good, service, activity, institution or business.

*Bandit Sign:* An illegally placed sign often used for advertising a service, business, or product.

*Directional Signs:* Any on-premise sign that directs the movement of traffic on private property within developments. Directional signs shall be located in a manner where they will not interfere with the safe movement of vehicles or pedestrians and shall not be located within any visibility triangle. Cannot be greater than twelve (12) square feet in area

*Freestanding Sign:* A sign that is not attached to a building and which is self-supported.

*Temporary Signs:* A sign constructed of a natural or man-made flexible material including, but not limited to, cloth, canvas, vinyl, engineered wood products not rated for outside use, or fabric which can be easily folded or rolled that is mounted with or without an enclosing framework that is attached or tethered to the building or structures. These signs are intended to be displayed for a limited period of time.

*Wall Sign:* Any sign attached to or projected from the exterior wall surface or facade of a building

*Wind Sign:* Any display or series of displays, banners, flags, pennants or other such objects designed and fashioned in such a manner as to move when subjected to wind pressure. Wind signs shall only be permitted as temporary signs. Feather Flags are the only type of wind driven signs allowed.

**No other changes are proposed.**

---

**SUBJECT**

Current Projects and City Council Status Update

**DEVELOPMENT INFORMATION**

The following is being provided for information purposes only so that the Planning and Zoning Commission is aware of the current status of new site plan applications, status of applications heard by the Commission and recommended for final action by the City Council, and the status of administratively approved applications.

**NEW SITE PLAN APPLICATIONS:** No new Site Plan Applications were submitted from May 28, 2025, to June 25, 2025.

**CITY COUNCIL RESULTS:** The following development applications were recommended for final action to the City Council:

- Ordinance 25-S-022- Conduct a public hearing and consider a request to rezone approximately 20 acres of land from Pre-Development District (PRE), Agricultural District (AD), and Single-Family Residential/Agricultural District (R-A) to Single-Family Residential District (R-2), generally located approximately 4,800 feet east of the intersection of FM 1518 and Lower Seguin Road, known as 12816 Lower Seguin Rd and 12746 Lower Seguin Road, and more specifically known as Bexar County Property Identification Numbers 310027, 310026, and 310028, City of Schertz, Bexar County, Texas.
  - Approved at the City Council meeting on June 3, 2025
- Ordinance 25-S-023- Conduct a public hearing and consider a request to rezone approximately 62 acres of land from Planned Development District (PDD) and Pre-Development District (PRE) to Single-Family Residential District (R-2), generally located approximately 3,800 feet east of the intersection of FM 1518 and Trainer Hale Road, known as Bexar County Property Identification number 310054, a portion of 310053 and a portion of 310061, City of Schertz, Bexar County, Texas.
  - Recommended for Approval by the Planning and Zoning Commission on May 7, 2025
  - Approved at the City Council meeting on June 3, 2025
- Ordinance 25-S-021- Conduct a public hearing and consider a request to rezone approximately 4.15 acres of land from General Business District (GB) to General Business District-2 (GB-2), generally located approximately 900 feet east of the intersection of FM 1518 and Maske Road, known as 46 Maske Road and 44 Maske Road, Lots 3 and 4, Block 1 of the Maske Road Business Park Subdivision, more specifically known as Guadalupe County Property Identification Numbers 199116, and 199117, City of Schertz, Guadalupe County, Texas.
  - Approved at the City Council meeting on June 3, 2025
- Ordinance 25-S-026- Conduct a public hearing and consider amendments to Part III of the Schertz Code of Ordinances Unified Development Code (UDC), to Article 8 Section 21.8.9 - Outdoor Display and Storage.
  - Recommended for approval with amendments by the Planning and Zoning Commission on June 4, 2025.
  - Scheduled for the July 1, 2025, City Council Meeting.
- Ordinance 25-S-027- Conduct a public hearing and consider a request to rezone approximately 19 acres of land from Single-Family Residential / Agricultural District (R-A) to Middle Density Residential District (R-5) known as Guadalupe County Property Identification Number 68302, and 68303, also known as 19018 Old Wiederstein Road, City of Schertz, Guadalupe County, Texas.
  - Recommended for approval by the Planning and Zoning Commission on June 4, 2025.

- Scheduled for the July 1, 2025, City Council Meeting.
- Ordinance 25-S-029-Conduct a public hearing and consider on a request to rezone approximately 173 acres of land from Agricultural District (AD) and Single-Family Residential / Agricultural District (R-A) to Single-Family Residential District (R-1), Single-Family Residential District (R-2), and Single-Family Residential District (R-6), known as Bexar County Property Identification Number 310012, 309425, 309427, generally located 1,000 feet to the west of Cibolo Creek on Lower Seguin Road, City of Schertz, Bexar County, Texas.
  - Recommended for approval by the Planning and Zoning Commission on June 4, 2025.
  - Scheduled for the July 1, 2025, City Council Meeting.
- Ordinance 25-S-024- Conduct a public hearing and consider amendments to Part III of the Schertz Code of Ordinances, Unified Development Code (UDC), to Article 11 - Sign and Advertising Devices, Article 3 Boards, Commissions, and Committees - Section 21.3.3 - Planning and Zoning Commission, Article 7 - Nonconforming Uses, Lots, and Structures, and Article 16 – Definitions.
  - Scheduled for the July 17, 2025, City Council Meeting.

**ADMINISTRATIVELY APPROVED PROJECTS:**

The following projects were administratively approved from May 28, 2025, to June 25, 2025:

- Riata Lift Station Subdivision
    - An administratively approved minor plat to establish Lot 1 Block 1 of the Riata Lift Station Subdivision.
-