

NOTICE TO THE PUBLIC
WILLIAMSON COUNTY COMMISSIONER'S COURT
FEBRUARY 27TH, 2018
9:30 A.M.

The Commissioner's Court of Williamson County, Texas will meet in regular session in the Commissioner's Courtroom, 710 Main Street, in Georgetown, Texas to consider the following items:

1. Review and approval of minutes.
2. Consider noting in minutes any off right-of-way work on any County road done by Road & Bridge Division.
3. Hear County Auditor concerning invoices, bills, Quick Check Report, wire transfers and electronic payments submitted for payment and take appropriate action including, but not limited to approval for payment provided said items are found by the County Auditor to be legal obligations of the county.
4. Citizen comments. Except when public hearings are scheduled for later in the meeting, this will be the only opportunity for citizen input. The Court invites comments on any matter affecting the county, whether on the Agenda or not. Speakers should limit their comments to three minutes. Note that the members of the Court may not comment at the meeting about matters that are not on the agenda.

CONSENT AGENDA

The Consent Agenda includes non-controversial and routine items that the Court may act on with one single vote. The Judge or a Commissioner may pull any item from the consent agenda in order that the court discuss and act upon it individually as part of the Regular Agenda.
 (Items 5 – 20)

5. Discuss and consider approving a line item transfer for the Constable Precinct #1 Office.

Fiscal Impact

From/To	Acct No.	Description	Amount
From	0100-0409-004998	Non Departmental/Contingencies	\$1,397.36
To	0100-0551-001114	Const #1/Certification Pay	\$1,149.25
To	0100-0551-002010	Const #1 /FICA	\$87.91
To	0100-0551-002020	Const #1/Retirement	\$160.20

6. Discuss, consider, and take appropriate action approving a line item transfer for County Attorney's Office.

Fiscal Impact

From/To	Acct No.	Description	Amount
From	0100.0475.004902	Co Atty Leg Supp	\$2,522.76
To	0100.0475.004999	Miscellaneous	\$1,112.76
To	0100.0475.004232	Training, Conf., Seminars	\$1,410.00

7. Discuss, consider and take appropriate action on a line item transfer for the 368th District Court.

Fiscal Impact

From/To	Acct No.	Description	Amount
From	0100-0409-004988	Non-Departmental/Contingencies	\$1,128.67
To	0100-0438-003010	Computer Equip. < \$5,000	\$1,128.67

8. Discuss, consider and take appropriate action on approving compensation changes, position titles changes, position grade changes and any corresponding line item transfers.
9. Discuss, consider and take appropriate action on authorizing the disposal of various county assets through auction including (1) 2011 Chevy Tahoe and (3) Dell Optiplex computers pursuant to Tx. Local Gov't Code 263.152.
10. Discuss, consider and take appropriate action on approving property tax collections for the month of January 2018 for the Williamson County Tax Assessor/Collector.
11. Discuss, consider and take appropriate action on approving property tax refunds over \$2,500.00 for the month of January 2018 for the Williamson County Tax Assessor/Collector.
12. Discuss, consider and take any necessary action to approve order for interment of deceased Williamson County resident (James H. Coward) where there has been no inquest by the Justice of the Peace and the county has duty to inter, pursuant to Tex. Health & Safety Code § 711.002(e), and authorize Beck Funeral Home to move forward with interment.
13. Discuss, consider and take appropriate action authorizing the County Judge to execute a Certificate of Approval relating to the Capital Area Housing Finance Corporation's Multifamily Housing Revenue Bonds for the Residences at Stillwater Apartments Project.
14. Discuss, consider and take appropriate action on accepting and approving a report on the Williamson County North Campus Project; Change Order #27 in the amount of \$2,687.00 for additional roller shades and a credit for window blinds, which was executed by Dwayne Gossett, Williamson County Facilities Project Manager, pursuant to the previous grant of authority under Section 262.031 of the Local Government Code. This change order is being funded out of the Owners Contingency.
15. Discuss, consider and take appropriate action on accepting and approving a report on the Williamson County North Campus Project; Change Order #40 in the amount of (\$6,292.00) to receive credit for deleted structural concrete, which was executed by Dwayne Gossett, Williamson County Facilities Project Manager, pursuant to the previous grant of authority under Section 262.031 of the Local Government Code. This change order is being credited to the Owners Contingency.
16. Discuss, consider and take appropriate action on accepting and approving a report on the Williamson County North Campus Project; Change Order #43 in the amount of \$24,129.00 for the addition of an HVAC unit at Stairwell # 2, which was executed by Dwayne Gossett, Williamson County Facilities Project Manager, pursuant to the previous grant of authority under Section 262.031 of the Local Government Code. This change order is to be funded by the Owners Contingency.

17. Discuss, consider and take appropriate action on accepting and approving a report on the Williamson County North Campus Project; Change Order #44 in the amount of \$4,882.00 for electrical modifications at warehouse per ASI-037, which was executed by Dwayne Gossett, Williamson County Facilities Project Manager, pursuant to the previous grant of authority under Section 262.031 of the Local Government Code. This change order is to be funded by the Owners Contingency.
18. Discuss, consider and take appropriate action on accepting and approving a report on the Jail Kitchen and Plumbing Remodel Project; Change Order # 3 in the amount of \$49,389.05 for additional HVAC and plumbing work, and safety upgrades associated with unforeseen conditions and safety items that were upgraded from the original specifications, which was executed by Dale Butler, Williamson County Facilities Project Manager, pursuant to the previous grant of authority under Section 262.031 of the Local Government Code. This change order is being funded out of the Owners Contingency.
19. Discuss, consider and take appropriate action on accepting and approving a report on the Jail Kitchen and Plumbing Remodel Project; Change Order # 4 in the amount of \$37,632.70 for additional HVAC and plumbing work associated with ASI # 3, scope deletion credit and Owner requested repairs and changes at kitchen doors and ceilings, which was executed by Dale Butler, Williamson County Facilities Project Manager, pursuant to the previous grant of authority under Section 262.031 of the Local Government Code. This change order is being funded out of the Owners Contingency.
20. Discuss, consider, and take appropriate action on approval of the preliminary plat for the Ranches at Salado Brook subdivision - Pct 3.

REGULAR AGENDA

21. Discuss and take appropriate action concerning the cancellation of Commissioners Court on March 13th, 2018.
22. 10:00 AM: Conduct public hearing pursuant to Texas Local Government Code Chapter 392 regarding a resolution to declare a need for a regional housing authority that would include Williamson County due to a shortage of safe or sanitary housing in Williamson County available to low-income persons at rents that they can afford and admitting Williamson County, Texas as a member of the Texas Housing Foundation, a Texas Regional Housing Authority.
23. Discuss, consider and take appropriate action on a resolution declaring a need for a regional housing authority that would include Williamson County due to a shortage of safe or sanitary housing in Williamson County available to low-income persons at rents that they can afford and admitting Williamson County, Texas as a member of the Texas Housing Foundation, a Texas Regional Housing Authority.
24. Discuss, consider and take appropriate action on appointing a commissioner for the Texas Housing Foundation Board of Commissioners to represent Williamson County on the Texas Housing Foundation Board to serve a two (2) year term commencing on March 1, 2018 and ending on February 29, 2020, pursuant to Texas Local Government Code Section 392.033.
25. Discuss, consider and take appropriate action on the Department of Infrastructure projects and issues update.
26. Receive and acknowledge the February 2018 Construction Summary Report for the Road Bond Program.

27. Discuss, consider, and take appropriate action regarding Change Order No. 5 in the amount of -\$2,831.05 for Pearson Ranch Road, a Road Bond Project in Commissioner Pct. 1. Project: P221 Pearson Ranch Road. Funding Source: Road Bond
28. Discuss, consider, and take appropriate action regarding Change Order No. 4 in the amount of \$154,700.48 for Pearson Ranch Road, a Road Bond Project in Commissioner Pct. 1. Project: P221 Pearson Ranch Road. Funding Source: Road Bond
29. Discuss, consider and take appropriate action on new Professional Service Agreement with Doucet & Associates, Inc. to provide Smith Branch Flood Control and Drainage Engineering Services for Williamson County Road and Bridge.
30. Discuss, consider and take appropriate action on Work Authorization No. 1 in the amount of \$114,250.00 to expire on September 30, 2018 under Williamson County Contract for Engineering Services between Doucet & Associates, Inc. and Williamson County dated February 27, 2018 for Smith Branch Flood Control and Drainage Engineering Services - Williamson County Juvenile Justice Center.
31. Discuss, consider and take appropriate action on the Williamson County North Campus Project; Change Order #39 from Vaughn Construction for time extension to the contract of 15 days due to inclement weather.
32. Discuss, consider and take appropriate action on the Williamson County North Campus Project; Change Order #42 from Vaughn Construction in the amount of (\$44,494.00) to receive credit for asphalt paving that was removed from the original scope of the project. This change order is being credited back to the Owners Contingency.
33. Discuss, consider and take appropriate action on a First Amendment to an Agreement Between Owner and Contractor, by and between Williamson County and STR Constructors, LTD. relating to the Williamson County Jail Kitchen and Plumbing Remodel Project.
34. Discuss, consider and take appropriate action on the Jail Kitchen and Plumbing Remodel Project; P411, Change Order # 5 from STR Constructors, LTD. in the amount of \$83,476.43 for additional electrical work associated with ASI # 3, and additional plumbing work in the main North Jail plumbing chases. This change order is being funded out of the Owners Contingency.
35. Discuss, consider and take appropriate action on a revised Resolution for the TxDOT Advance Funding Agreement for Bridge Replacement or Rehabilitation Off the State System in regards to the CR 456 truss bridge in Coupland.
36. Discuss, consider and take appropriate action on a real estate contract with Daniel and Crystal Corbell for right of way needed on CR 200 (Parcel 22). Funding Source Road Bonds P285
37. Discuss, consider and take appropriate action on a real estate contract with Joseph and Holli Pietropaolo for right fo way needed on CR 200 (Parcel 18). Funding Source Road Bonds P285
38. Discuss, consider and take appropriate action on an escrow agreement with Chandler Creek LP regarding work to be done by the County as a part of the construction of the N. Mays project. (Parcel 7). Funding Source: General Funds
39. Discuss and take appropriate action to amend 2014 Tax Benefit Financing enrollment list to include Bar-W Ranch (formerly Wedemeyer Ranch) under Williamson County Conservation Foundation File number 20141223.

40. Discuss, consider, and take appropriate action on the use of unallocated funds on the law enforcement scale in the County Attorney's office in the amount of \$3,167.82.
41. Discuss, consider, and take appropriate action on approving a Supplemental Agreement to the Agreement for Architectural and Engineering Services, originally procured under RFQ#14RFQ00108, between Populous, Inc. and Williamson County relating to additional architectural and engineering services for construction programming, design and construction administration in the amount of \$233,000 to support the operations of the Williamson County Expo Center and authorizing execution of the agreement.
42. Discuss, consider, and take appropriate action on approving the agreements between Amarillo Junior College District and Williamson County for Technical Training (#180001 Air Generative Sweeper; #180002 Telescopic Hydraulic Excavator; and #180003 Asphalt Distributor) in the amount totaling \$13,965.00.
43. Discuss, consider, and take appropriate action on approving purchase of gym equipment from Marathon Fitness for the new Sheriff's Office Training Facility in the amount of \$101,143.68, pursuant to BuyBoard contract # 502-16.
44. Discuss, consider, and take appropriate action on approving purchase of gym equipment for the new Sheriff's Office Training Facility from Fringe Sport in the amount of \$3,821.37, and asking the Commissioners Court to waive the three (3) quote requirement as required by the Williamson County Purchasing Policy.
45. Discuss, consider, and take appropriate action on approving purchase of Ice Maker from LoneStar Restaurant Supply for the new Sheriff's Office Training Facility, in the amount of \$2,569.00, and asking the Commissioners Court to waive the three (3) quote requirement as required by the Williamson County Purchasing Policy.
46. Discuss, consider, and take appropriate action on awarding RFP# 1771-204, for Quality Assurance Evaluation for Emergency Communication Radio Traffic Services, to the only proposal, The Denise Amber Lee Foundation, INC and authorizing the execution of the agreement.

EXECUTIVE SESSION

"The Commissioners Court for Williamson County reserves the right to adjourn into executive session at any time during the course of this meeting to discuss any of the matters listed above, as authorized by Texas Government Code Sections 551.071 (Consultations with Attorney), 551.072 (Deliberations regarding Real Property), 551.073 (Deliberations regarding Gifts and Donations), 551.074 (Personnel Matters), 551.076 (Deliberations regarding Security Devices) and 551.087 (Deliberations regarding Economic Development Negotiations)."

47. Discussion regarding economic development negotiations pursuant to Texas Government Code, Section 551.087:
 - a) Business prospect(s) that may locate or expand within Williamson County.
 - b) Discuss North Woods Road District.
 - c) Project Amazon
 - d) Wolf Lakes

48. Discuss real estate matters (EXECUTIVE SESSION as per VTCA Govt. Code sec. 551.072 Deliberation Regarding Real Estate Property if deliberation in an open meeting would have a detrimental effect on the position of the governmental body in negotiations with third person.)
- A. Real Estate Owned by Third Parties
1. Preliminary discussions relating to proposed or potential purchase or lease of property owned by third parties
 - a) Discuss the acquisition of real property for right-of-way for N. Mays St. Extension
 - b) Discuss the acquisition of real property for SW 183 and SH 29 Loop.
 - c) Discuss the acquisition of real property for CR 176 at RM 2243
 - d) Discuss the acquisition of real property: CR 101
 - e) Discuss the acquisition of real property: CR 200
 - f) Discuss the acquisition of real property for CR 278 at Bagdad Rd.
 - g) Discuss the acquisition of real property for proposed CR 110 project. (All sections)
 - h) Discuss the acquisition of real property for County Facilities.
 - i) Discuss the acquisition of Easement interests for the Brushy Creek Trail Project.
 - j) Discuss the acquisition of real property and easements from San Gabriel River Ranch Subdivision.
 - k) Discuss the acquisition of real property for CR 278 @ Bagdad Rd.
 - l) Discuss the acquisition of real property for Seward Junction SE Loop.
 - m) Discuss the acquisition of real property for SH 29 @ DB Wood.
 - n) Discuss the acquisition of real property for Hairy Man Rd.
 - o) Discuss the acquisition of real property for SW Bypass.
 - p) Discuss Somerset Road Districts No. 3 & 4 reimbursements for acquisition & construction of Reagan Blvd.
 - q) Discuss Cedar Hollow low water crossings and Lost River.
- B. Property or Real Estate owned by Williamson County
- 1). Preliminary discussions relating to proposed or potential sale or lease of property owned by the County
 - a) Discuss County owned real estate containing underground water rights and interests.
 - b) Discuss wastewater easements in Berry Springs Park
 - c) Discuss sale of County property on Ronald Reagan Blvd.
 - d) Discuss possible sale of +/- 10 acres located on Chandler Road near the County Sheriff's Office Training Facility
 - e) Potential governmental uses for 8th Street downtown parking lot
- C. Consider intervention in lawsuit regarding de-listing of Bone Cave harvestman.
- D. Discuss the possible placement of agricultural-related monuments at the Williamson County Exposition Center with the participation of third parties.
- E. Discuss the San Gabriel River trail easements.
49. Discuss pending or contemplated litigation, settlement matters and other confidential attorney-client legal matters (EXECUTIVE SESSION as per VTCA Govt. Code sec. 551.071 consultation with attorney.), including the following:
- a) Litigation or claims or potential litigation or claims against the County or by the County
 - b) Status Update-Pending Cases or Claims;
 - c) Civil Action No.1:13- CV- 505, Robert Lloyd v. Lisa Birkman, et al, In The United States District Court for the Western District of Texas, Austin Division
 - d) Employee/personnel related matters
 - e) Other confidential attorney-client matters, including contracts and certain matters related to county defense issues in which the duty of the attorney to the governmental body within the attorney/client relationship clearly conflicts with Chapter 551 of the Texas Government Code.
 - f) Cause No. 15-0064-C277, Gordon v. Dollahite et al, In The District Court of Williamson County, Texas, 277th District
 - g) Civil Action No. 1:15-cv-431; Herman Crisp v. Williamson County, et al; In the USDC-WD-Austin Division
 - h) Carolyn Barnes, et al v. Texas Attorney General, et al; Cause # D-1-GN-15-000877, in the 419th Judicial District Court of Travis County
 - i) Appeal of IRS Proposed Worker Classification Changes and Proposed Tax Adjustments 2011 -2013; and Payment of Disputed Employment Taxes Pending Appeal
 - j) Discuss proposed acquisition of property for SW 183 and SH 29 Loop

- k) Civil Action; American Stewards of Liberty, et al. v. Sally Jewell, et al., In the Western District Court, Western District of Texas, Austin Division
- l) Berry Springs Park and Preserve pipeline
- m) Case No. 1:17-cv-00290, Rodney A. Hurdsmen v. Williamson County Sheriff Deputies Pokluda et al, In The United States District Court For The Western District of Texas – Austin Division.
- n) Civil Action No. 1:17-cv-153-SS, Royce Belcher v. Williamson County, Texas, In The United States District Court for the Western District of Texas, Austin Division.
- o) Tax Increment Financing Agreement between Williamson County and the City of Hutto with respect to a proposed tax increment reinvestment zone (TIRZ) in Hutto, Teexas.
- p) Williamson County Sheriff's Office Training Center construction issues.
- q) Application to Obtain New Municipal Solid Waste Permit – Proposed Permit No. 2398 (Applicant - Lealco, Inc.)
- r) LCRA TSC Leander-Round Rock 138-Kv Transmission Line Project within the Public Right-Of-Way (Row) of New Hope Road, Ronald Reagan Boulevard, and Hero Way
- s) Employment law claims of Michelle Williams, Andrenia McGowen and/or Raphaela Johnson.
- t) Civil Action No. 1:17-cv-01114-LY, Elizabeth Saucedo v. Jonathon Hodgkiss, In The United States District Court for the Western District of Texas, Austin Division.
- u) Civil Action No. 1:17-cv-01113-LY, Tettus Davis v. Jonathon Hodgkiss, In The United States District Court for the Western District of Texas, Austin Division.
- v) Farm and Grazing Lease with Mary Brett Covington dated effective March 29, 2016 on county land near County Road 131
- w) Amendment to Interlocal Lease Agreement between Williamson County and City of Georgetown relating to Williamson County's property located near Martin Luther King Boulevard and 8th Streets in Georgetown, Texas
- x) Civil Action No. 1:18-CV-49, Troy Mansfield v. Williamson County, In The United States District Court for the Western District of Texas, Austin Division.
- y) Utility damage claim from Suddenlink Communications occurring on or about 03/27/2017 at CR 366 and SH 29.

- 50. Deliberate the appointment, employment, evaluation, reassignment, duties, discipline and/or dismissal of Williamson County officers, directors, employees and/or positions, including but not limited to conducting deliberation and discussion pertaining to annual reviews of department heads and appointed officials (Executive Session as per Tex. Gov. Code Section 551.074 – Personnel Matters).
- 51. Discuss the deployment or specific occasions for implementation of security personnel or devices in relation to the Williamson County Justice Center (Executive Session as per Texas Gov't. Code § 551.076).

REGULAR AGENDA (continued)

- 52. Discuss and take appropriate action concerning economic development.
- 53. Discuss and take appropriate action concerning real estate.
- 54. Discuss and take appropriate action on pending or contemplated litigation, settlement matters and other confidential attorney-client legal matters, including the following:
 - a) Litigation or claims or potential litigation or claims against the County or by the County
 - b) Status Update-Pending Cases or Claims;
 - c) Civil Action No.1:13- CV- 505, Robert Lloyd v. Lisa Birkman, et al, In The United States District Court for the Western District of Texas, Austin Division
 - d) Employee/personnel related matters
 - e) Other confidential attorney-client matters, including contracts and certain matters related to county defense issues in which the duty of the attorney to the governmental body within the attorney/client relationship clearly conflicts with Chapter 551 of the Texas Government Code.
 - f) Cause No. 15-0064-C277, Gordon v. Dollahite et al, In The District Court of Williamson County, Texas, 277th District

- g) Civil Action No. 1:15-cv-431; Herman Crisp v. Williamson County, et al; In the USDC-WD-Austin Division
- h) Carolyn Barnes, et al v. Texas Attorney General, et al; Cause # D-1-GN-15-000877, in the 419th Judicial District Court of Travis County
- i) Discuss, consider and take appropriate action regarding possible appeal of IRS Proposed Worker Classification Changes and Proposed Tax Adjustments 2011 -2013; and approval of payment of disputed employment taxes pending appeal
- j) Discuss proposed acquisition of property for SW 183 and SH 29 Loop
- k) Civil Action; American Stewards of Liberty, et al. v. Sally Jewell, et al., In the Western District Court, Western District of Texas, Austin Division
- l) Berry Springs Park and Preserve pipeline
- m) Case No. 1:17-cv-00290, Rodney A. Hurdsman v. Williamson County Sheriff Deputies Pokluda et al, In The Unites States District Court For The Western District of Texas – Austin Division.
- n) Civil Action No. 1:17-cv-153-SS, Royce Belcher v. Williamson County, Texas, In The United States District Court for the Western District of Texas, Austin Division.
- o) Tax Increment Financing Agreement between Williamson County and the City of Hutto with respect to a proposed tax increment reinvestment zone (TIRZ) in Hutto, Texas.
- p) Williamson County Sheriff's Office Training Center construction issues.
- q) Application to Obtain New Municipal Solid Waste Permit – Proposed Permit No. 2398 (Applicant - Lealco, Inc.)
- r) LCRA TSC Leander-Round Rock 138-Kv Transmission Line Project within the Public Right-Of-Way (Row) of New Hope Road, Ronald Reagan Boulevard, and Hero Way
- s) Employment law claims of Michelle Williams, Andrenia McGowen and/or Raphaela Johnson.
- t) Civil Action No. 1:17-cv-01114-LY, Elizabeth Saucedo v. Jonathon Hodgkiss, In The United States District Court for the Western District of Texas, Austin Division.
- u) Civil Action No. 1:17-cv-01113-LY, Tettus Davis v. Jonathon Hodgkiss, In The United States District Court for the Western District of Texas, Austin Division.
- v) Farm and Grazing Lease with Mary Brett Covington dated effective March 29, 2016 on county land near County Road 131
- w) Amendment to Interlocal Lease Agreement between Williamson County and City of Georgetown relating to Williamson County's property located near Martin Luther King Boulevard and 8th Streets in Georgetown, Texas
- x) Civil Action No. 1:18-CV-49, Troy Mansfield v. Williamson County, In The United States District Court for the Western District of Texas, Austin Division.
- y) Utility damage claim from Suddenlink Communications occurring on or about 03/27/2017 at CR 366 and SH 29.

- 55. Discuss, consider and take appropriate action regarding the appointment, employment, evaluation, reassignment, duties, discipline and/or dismissal of Williamson County officers, directors or employees, including but not limited to any necessary action pertaining to conducting annual reviews of department heads and appointed officials.
- 56. Comments from Commissioners.
- 57. Recess until 1:30 PM
Budget Kickoff Workshop with Commissioners Court, Human Resources and Auditor's Office to set goals, priorities and objectives for the 2018-2019 budget.

Dan A. Gattis, County Judge

This notice of meeting was posted in the locked box located on the south side of the Williamson County Courthouse, a place readily accessible to the general public at all times, on the _____ day of _____, 2018 at _____ and remained posted for at least 72 continuous hours preceding the scheduled time of said meeting.

Commissioners Court - Regular Session

5.

Meeting Date: 02/27/2018

Line Item Transfer

Submitted By: Sarah Crain, Budget Office

Department: Budget Office

Agenda Category: Consent

Information

Agenda Item

Discuss and consider approving a line item transfer for the Constable Precinct #1 Office.

Background

A transfer came over from the SO into a vacant position in the Constable Pct #1 Office in which certification pay was not budgeted at the time since they did not know who the new hire would be. In addition, there was a second position which was recommended for certification pay but was inadvertently not linked, causing the funding not to be added to the department's budget.

Fiscal Impact

From/To	Acct No.	Description	Amount
From	0100-0409-004998	Non Departmental/Contingencies	\$1,397.36
To	0100-0551-001114	Const #1/Certification Pay	\$1,149.25
To	0100-0551-002010	Const #1 /FICA	\$87.91
To	0100-0551-002020	Const #1/Retirement	\$160.20

Attachments

No file(s) attached.

Form Review

Inbox

County Judge Exec Asst.

Form Started By: Sarah Crain

Final Approval Date: 02/21/2018

Reviewed By

Wendy Coco

Date

02/21/2018 04:25 PM

Started On: 02/21/2018 08:30 AM

Commissioners Court - Regular Session

6.

Meeting Date: 02/27/2018

Line Item Transfer

Submitted For: D. Hobbs

Submitted By: Stephanie Lloyd, County Attorney

Department: County Attorney

Agenda Category: Consent

Information

Agenda Item

Discuss, consider, and take appropriate action approving a line item transfer for County Attorney's Office.

Background

Transfer funds from CA Leg Supp to pay for Victim Advocate plaques and training expenses

Fiscal Impact

From/To	Acct No.	Description	Amount
From	0100.0475.004902	Co Atty Leg Supp	\$2,522.76
To	0100.0475.004999	Miscellaneous	\$1,112.76
To	0100.0475.004232	Training, Conf., Seminars	\$1,410.00

Attachments

No file(s) attached.

Form Review

Inbox

County Judge Exec Asst.
 Budget Office
 Form Started By: Stephanie Lloyd
 Final Approval Date: 02/22/2018

Reviewed By

Wendy Coco
 Ashlie Koenig

Date

02/22/2018 09:27 AM
 02/22/2018 09:38 AM
 Started On: 02/21/2018 08:10 PM

Commissioners Court - Regular Session

7.

Meeting Date: 02/27/2018

Line Item Transfer

Submitted By: Sarah Crain, Budget Office

Department: Budget Office

Agenda Category: Consent

Information

Agenda Item

Discuss, consider and take appropriate action on a line item transfer for the 368th District Court.

Background

Moving funds for a new computer necessary on the bench in the 368th Judicial District Court. The Judge's bench computer is having problems and cannot be repaired by IT. Funding is not available in the departmental budget for this unexpected purchase.

Fiscal Impact

From/To	Acct No.	Description	Amount
From	0100-0409-004988	Non-Departmental/Contingencies	\$1,128.67
To	0100-0438-003010	Computer Equip. < \$5,000	\$1,128.67

Attachments

Computer Replacement Quote

Form Review

Inbox

County Judge Exec Asst.

Form Started By: Sarah Crain

Final Approval Date: 02/22/2018

Reviewed By

Wendy Coco

Date

02/22/2018 11:03 AM

Started On: 02/22/2018 10:08 AM



A quote for your consideration!

Total: \$1,128.67

Based on your business needs, we put the following quote together to help with your purchase decision. Please review your quote details below, then contact your sales rep when you're ready to place your order.

Quote number: 3000022095370.1	Quote date: Feb. 8, 2018	Quote expiration: Mar. 10, 2018	Deal ID: 15464627
---	------------------------------------	---	-----------------------------

Company name: WILLIAMSON COUNTY ITS	Customer number: 10643470	Phone: (512) 943-1456
---	-------------------------------------	---------------------------------

Sales rep information: Danielle Eads Danielle_Eads@Dell.com (800) 456-3355 Ext: 5139354	Billing Information: WILLIAMSON COUNTY ITS 301 SE INNER LOOP STE 105 GEORGETOWN TX 78626-8207 US (512) 943-1456
--	---

Pricing Summary

Item	Qty	Unit Price	Subtotal
OptiPlex 7450 AIO	1	\$1,052.56	\$1,052.56
Dell OptiPlex 24 7000 Series All-in-One Articulating Stand	1	\$76.11	\$76.11
		Subtotal:	\$1,128.67
		Shipping:	\$0.00
		Environmental Fees:	\$0.00
		Non-Taxable Amount:	\$1,128.67
		Taxable Amount:	\$0.00
		Estimated Tax:	\$0.00
		Total:	\$1,128.67

Special lease pricing may be available for qualified customers. Please contact your DFS Sales Representative for details.

Dear Customer,

Your Quote is detailed below; please review the quote for product and information accuracy. If you find errors or desire certain changes please contact me as soon as possible.

Regards,
Danielle Eads

Order this quote easily online through your [Premier page](#), or if you do not have Premier, using [Quote to Order](#)

Shipping Group 1

Shipping Contact: MCCULLEY TAMMY	Shipping phone: (512) 943-1455	Shipping via: Standard Ground	Shipping Address: 301 SE INNER LOOP STE 105 GEORGETOWN TX 78626-8207 US
--	--	---	---

SKU	Description	Qty	Unit Price	Subtotal
	OptiPlex 7450 AIO	1	\$1,052.56	\$1,052.56
	Estimated delivery date: Feb. 20, 2018			
	Contract No: 75AHH			
	Customer Agreement No: DIR-TSO-3763			
210-AKMX	BASE,AIO,OPTI,7450,CTO,WW	1	-	-
338-BKYY	Intel Core i5-7500 (QC/6MB/4T/3.4GHz/65W); supports Windows 10/Linux	1	-	-
619-AHKN	Win 10 Pro 64 English, French, Spanish	1	-	-
658-BCSB	Microsoft(R) Office 30 Days Trial	1	-	-
370-ADJL	8GB (2x4GB) 2400MHz DDR4	1	-	-
400-ANPO	500GB 2.5inch Serial ATA (7,200 Rpm) Hard Drive	1	-	-
401-AADF	No Additional Hard Drive	1	-	-
817-BBBN	NO RAID	1	-	-
409-BBCF	No Intel Rapid Start or Smart Connect	1	-	-
575-BBHQ	Basic Stand for OptiPlex 7440/7450	1	-	-
490-BBFG	Intel Integrated Graphics, Dell OptiPlex	1	-	-
325-BBUB	8xDVD 9.5mm Optical Disk Drive	1	-	-
429-AAVN	8x DVD-ROM 9.5mm Optical Disk Drive	1	-	-

555-BDGO	Intel Dual Band Wireless AC 8265 (802.11ac) 2x2 + Bluetooth	1	-	-
555-BDIO	Intel Dual Band Wireless 8265 (802.11ac) Driver	1	-	-
391-BDHK	Dell Touch Liquid Crystal Display, Dell OptiPlex 7450AIO	1	-	-
329-BDHW	7450 AIO 23.8, FHD Touch with Camera, Integrated Graphics, Bronze PSU	1	-	-
461-AABV	No Accessories	1	-	-
580-ADJM	Dell KM636 Wireless Keyboard & Mouse English, Black	1	-	-
570-AADI	Mouse included with Keyboard	1	-	-
631-ABEU	No Out-of-Bands Systems Management	1	-	-
525-BBCL	SupportAssist	1	-	-
640-BBLW	Dell(TM) Digital Delivery Cirrus Client	1	-	-
658-BBMR	Dell Client System Update (Updates latest Dell Recommended BIOS, Drivers, Firmware and Apps)	1	-	-
658-BBRB	Waves Maxx Audio	1	-	-
658-BCUV	Dell Developed Recovery Environment	1	-	-
620-AALW	OS-Windows Media Not Included	1	-	-
387-BBLW	E-Star 6.1 & TCO 5.0 Driver, Service Install Module	1	-	-
332-1286	US Order	1	-	-
340-ABJI	No Diagnostic/Recovery CD media	1	-	-
340-BJWF	MOD,PLCMT,QSG,W10,7450,DAO	1	-	-
658-BBTV	CMS Essentials DVD no Media	1	-	-
450-AAOJ	System Power Cord (Philipine/TH/US)	1	-	-
329-BBJL	TPM Enabled	1	-	-
389-BCGW	No UPC Label	1	-	-
389-BRFZ	MOD,LBL,REG,JSD2,NON-GS,7450	1	-	-
340-AGIK	Safety/Environment and Regulatory Guide (English/French Multi-language)	1	-	-
340-BJWH	MOD,SHP MTL,TAR,AIO23.8,DAO	1	-	-
389-BBUU	Shipping Label for DAO	1	-	-
389-BLSV	Intel Core i5 Processor Kabylake Label	1	-	-

800-BBIO	Desktop BTO Standard shipment	1	-	-
817-BBBB	No FGA	1	-	-
997-6870	Dell Limited Hardware Warranty Plus Service	1	-	-
997-6872	Onsite/In-Home Service After Remote Diagnosis 3 Years	1	-	-

SKU	Description	Qty	Unit Price	Subtotal
	Dell OptiPlex 24 7000 Series All-in-One Articulating Stand	1	\$76.11	\$76.11
	Estimated delivery date: Feb. 14, 2018			
	Contract No: 75AHH			
	Customer Agreement No: DIR-TSO-3763			
452-BCCG	Dell OptiPlex 24 7000 Series All-in-One Articulating Stand	1	-	-

Subtotal:	\$1,128.67
Shipping:	\$0.00
Environmental Fees:	\$0.00
Estimated Tax:	\$0.00
Total:	\$1,128.67

Important Notes

Terms of Sale

Unless you have a separate written agreement that specifically applies to this order, your order will be subject to and governed by the following agreements, each of which are incorporated herein by reference and available in hardcopy from Dell at your request: Dell's Terms of Sale (www.dell.com/learn/us/en/uscop1/terms-of-sale), which include a binding consumer arbitration provision and incorporate Dell's U.S. Return Policy (www.dell.com/returnpolicy) and Warranty (for [Consumer warranties](#) ; for [Commercial warranties](#)).

If this purchase includes services: in addition to the foregoing applicable terms, the terms of your service contract will apply ([Consumer](#); [Commercial](#)). If this purchase includes software: in addition to the foregoing applicable terms, your use of the software is subject to the license terms accompanying the software, and in the absence of such terms, then use of the Dell-branded application software is subject to the Dell End User License Agreement - Type A (www.dell.com/AEULA) and use of the Dell-branded system software is subject to the Dell End User License Agreement - Type S (www.dell.com/SEULA).

If your purchase is for Mozy, in addition to the foregoing applicable terms, your use of the Mozy service is subject to the terms and conditions located at <https://mozy.com/about/legal/terms>.

You acknowledge having read and agree to be bound by the foregoing applicable terms in their entirety. Any terms and conditions set forth in your purchase order or any other correspondence that are in addition to, inconsistent or in conflict with, the foregoing applicable online terms will be of no force or effect unless specifically agreed to in a writing signed by Dell that expressly references such terms.

Pricing, Taxes, and Additional Information

All product, pricing, and other information is valid for U.S. customers and U.S. addresses only, and is based on the latest information available and may be subject to change. Dell reserves the right to cancel quotes and orders arising from pricing or other errors. Please indicate any tax-exempt status on your PO, and fax your exemption certificate, including your Customer Number, to the Dell Tax Department at 800-433-9023. Please ensure that your tax-exemption certificate reflects the correct Dell entity name: **Dell Marketing L.P.**

Note: All tax quoted above is an estimate; final taxes will be listed on the invoice.

If you have any questions regarding tax please send an e-mail to Tax_Department@dell.com.

For certain products shipped to end-users in California, a State Environmental Fee will be applied to your invoice. Dell encourages customers to dispose of electronic equipment properly.

Commissioners Court - Regular Session

8.

Meeting Date: 02/27/2018

Compensation Items

Submitted For: Tara Raymore

Submitted By: Kristy Sutton, Human Resources

Department: Human Resources

Agenda Category: Consent

Information

Agenda Item

Discuss, consider and take appropriate action on approving compensation changes, position titles changes, position grade changes and any corresponding line item transfers.

Background

See attached documentation for details.

Fiscal Impact

From/To	Acct No.	Description	Amount
---------	----------	-------------	--------

Attachments

[Merit Details 02.27.18](#)

[Merit LIT 02.27.18](#)

Form Review

Inbox

Human Resources (Originator)

County Judge Exec Asst.

Form Started By: Kristy Sutton

Final Approval Date: 02/22/2018

Reviewed By

Tammy Fennell

Wendy Coco

Date

02/22/2018 11:29 AM

02/22/2018 11:32 AM

Started On: 02/22/2018 09:47 AM

Department	Position	Emp ID Num	Current Annual Salary	Annual Merit Amt	Merit %	New Annual Salary	Pay Proposal Reason	Effective Date of Change
911 Communications	Captain.0117.001100.	4012	\$65,816.32	\$1,974.48	3.00	\$67,790.80	MERIT	2/23/2018
911 Communications	Captain.0168.001100.	4107	\$61,453.16	\$3,072.66	5.00	\$64,525.82	MERIT	2/23/2018
911 Communications	Captain.0115.001100.	4580	\$60,572.43	\$1,817.17	3.00	\$62,389.60	MERIT	2/23/2018
911 Communications	Telecom Ofcr IV.0169.001100.	5461	\$59,264.25	\$1,777.92	3.00	\$61,042.18	MERIT	2/23/2018
911 Communications	Lieutenant.0160.001100.	10358	\$59,381.23	\$1,781.44	3.00	\$61,162.67	MERIT	2/23/2018
911 Communications	Telecom Ofcr IV.0172.001100.	10377	\$54,833.31	\$1,645.01	3.00	\$56,478.32	MERIT	2/23/2018
911 Communications	Lieutenant.0163.001100.	10794	\$57,921.78	\$1,737.65	3.00	\$59,659.43	MERIT	2/23/2018
911 Communications	Telecom Ofcr IV.0122.001100	11218	\$49,970.25	\$1,499.10	3.00	\$51,469.35	MERIT	2/23/2018
911 Communications	Prof Dev Mgr.0165.001100.	11480	\$69,283.24	\$2,078.44	3.00	\$71,361.68	MERIT	2/23/2018
911 Communications	Telecom Ofcr IV.0156.001100	11859	\$44,987.47	\$1,349.63	3.00	\$46,337.10	MERIT	2/23/2018
911 Communications	Lieutenant.0161.001100.	12256	\$51,684.40	\$1,550.54	3.00	\$53,234.94	MERIT	2/23/2018
911 Communications	Telecom Ofcr III.0138.001100	13260	\$45,259.93	\$1,810.39	4.00	\$47,070.32	MERIT	2/23/2018
911 Communications	Telecom Ofcr IV.0170.001100.	13289	\$44,987.47	\$1,304.64	2.90	\$46,292.11	MERIT	2/23/2018
911 Communications	Telecom Ofcr III.0158.001100.	13492	\$41,989.36	\$1,049.73	2.50	\$43,039.09	MERIT	2/23/2018
911 Communications	Telecom Ofcr III.0130.001100	13574	\$40,766.38	\$1,223.00	3.00	\$41,989.38	MERIT	2/23/2018
911 Communications	Telecom Ofcr III.0132.001100	13602	\$40,766.38	\$1,223.00	3.00	\$41,989.38	MERIT	2/23/2018
Human Resources	Sr HR Specialist.0006.001100	14406	\$40,766.19	\$1,019.16	2.50	\$41,785.35	MERIT	2/23/2018
Juvenile Services	Juv Detn Officer.1114.001100.	14129	\$36,175.82	\$1,085.28	3.00	\$37,261.10	MERIT	3/9/2018

				(TO)	(FROM)
entity	fund	dept	object	dr	cr
01	0100	8004	001100	26,894.80	
01	0100	8004	002010	2,057.45	
01	0100	8004	002020	3,749.13	
01	0100	8004	001130		26,894.80
01	0100	8004	002010		2,057.45
01	0100	8004	002020		3,749.13
01	0100	0402	001100	1,019.16	
01	0100	0402	001130		1,019.16
01	0100	0576	001100	1,085.28	
01	0100	0576	001130		1,085.28

Commissioners Court - Regular Session

9.

Meeting Date: 02/27/2018

Asset Auction 2/27/2018

Submitted For: Randy Barker

Submitted By: Jayme Jasso, Purchasing

Department: Purchasing

Agenda Category: Consent

Information

Agenda Item

Discuss, consider and take appropriate action on authorizing the disposal of various county assets through auction including (1) 2011 Chevy Tahoe and (3) Dell Optiplex computers pursuant to Tx. Local Gov't Code 263.152.

Background

Please see attached documents for detail.

Fiscal Impact

From/To	Acct No.	Description	Amount
---------	----------	-------------	--------

Attachments

[Asset Auction 1](#)

[Asset Auction 2](#)

Form Review

Inbox

Purchasing (Originator)
County Judge Exec Asst.
Form Started By: Jayme Jasso
Final Approval Date: 02/22/2018

Reviewed By

Randy Barker
Wendy Coco

Date

02/22/2018 10:26 AM
02/22/2018 11:03 AM
Started On: 02/22/2018 09:10 AM

Vehicle Status Change

Reason for Status Change	REACHED OPERATIONAL LIFE EXPECTANCY: see comments
Department	551- Constable Pct 1
County VIN/Serial Number	1GNLC2E0XBR209499
Equipment/Door Number	1B1124
License Plate	111-0204
Year	2011
Make	CHEVROLET
Model	TAHOE
Comments	110,693 miles
Elected Official/Department Head/Authorized Staff Digital Signature	✓ Vinnie Cherrone 2/2/2018 11:47 AM
Department Transfer	
Receiving Department Signature	✗
Budget Office Signature Acknowledgement	✗
To be completed by Fleet Services Manager	
Method of Status change: This vehicle is to be considered for: (select one)	Sale at the earliest auction
Fleet Comments	110,693 miles
Authorized Fleet Staff Digital Signature	✓ Kevin Teller 2/2/2018 1:50 PM
To be completed by HR - Signature acknowledges that there all paperwork has been received and there are no pending litigations	
Authorizing HR Employee Digital Signature	✓ Heather Kirkwood 2/12/2018 10:20 AM
To be completed by Auditor's Office	
Electronic Signature indicates the Vehicle Status Change has been reviewed and approved.	
Title Approved for (Audit)	No change needed; current title is still valid
Auditor's Authorized Employee Digital Signature	✓ Angela Schmidt 2/20/2018 10:05 AM
To be completed by Purchasing Department	
Purchasing Department Signature Acknowledgement	✓ Jayme Jasso 2/22/2018 9:12 AM

Human Resources

Created by Williamson County Technology Services

Williamson County Asset Status Change Form

The following asset(s) is(are) considered for: (select one)

- | | |
|--|---|
| <input type="radio"/> TRANSFER bet ween county departments | <input type="radio"/> DONATION to a non-county entity |
| <input checked="" type="radio"/> SALE at the earliest auction * | <input type="radio"/> DESTRUCTION due to Public Health / Safety |
| <input type="radio"/> TRADE-IN for new assets of similar type for the county | <input type="radio"/> SALE to a government entity / civil or charitable organization in the county at fair market value |

Asset List:

Quantity	Description (year, make, model, etc.)	Manufacturer ID# (serial, service tag, or VIN)	County Tag#	Condition of Assets (Working, Non-Working)
1	Dell Optiplex 7010	77231, 77227, 77226 V0P0Y1, J0G0G11, J0G0G11		Working
12	Dell Optiplex 780	55538, 55541, 55540 57BT3P1 67BT3P1, 57BT3P1		Working
1	Dell Optiplex 790	G3LJHS1 57572		Working
1	Fila Bed Paper Cutter	N/A		Non-Working
2	2 hole punchers	N/A		Non-Working

Parties involved:

FROM (Transferor Department): County Clerk's Office

Transferor - Elected Official/Department Head/Authorized Staff:

Nancy E Rister

Print Name

Nancy E. Rister
Signature

Date

Contact Person:

Terri Countess

Print Name

+1 (512) 943-1976

Phone Number

TO (Transferee Department/Auction/Trade-in/Donee): Auction

Transferee - Elected Official/Department Head/Authorized Staff OR Donee - Representative: (If being approved for Sale or Trade-in, no signature is necessary.)

Contact Person:

RECEIVED

Print Name

Print Name

FEB 16 2018

Signature

Date

Phone Number

AUDITOR'S OFFICE
WILLIAMSON COUNTY, TEXAS

* If the above asset(s) is (are) listed for sale at auction and no bids are made, the Purchasing Director may dispose of or donate this (these) asset(s). A list of the (these) asset(s) to be donated or disposed of will be sent to the Auditor's Office with a date of donation or disposal.

Forward to County Auditor's Office

This Change Status was approved as agenda item # _____ in Commissioner's Court on _____

If for Sale, the asset(s) was(were) delivered to warehouse on _____ by _____

Commissioners Court - Regular Session

10.

Meeting Date: 02/27/2018

Property Tax Collections - January 2018

Submitted For: Larry Gaddes

Submitted By: Cathy Atkinson, County Tax Assessor Collector

Department: County Tax Assessor Collector

Agenda Category: Consent

Information

Agenda Item

Discuss, consider and take appropriate action on approving property tax collections for the month of January 2018 for the Williamson County Tax Assessor/Collector.

Background

Fiscal Impact

From/To	Acct No.	Description	Amount
---------	----------	-------------	--------

Attachments

[010118-013118 GWI-RFM](#)

[010118-013118 GWI-RFM Graph](#)

Form Review

Inbox

County Judge Exec Asst.

Form Started By: Cathy Atkinson

Final Approval Date: 02/21/2018

Reviewed By

Wendy Coco

Date

02/21/2018 04:25 PM

Started On: 02/15/2018 04:00 PM

YEAR TO DATE - COLLECTION REPORT
Williamson County - GWI/RFM Property Taxes
January 31, 2018

Williamson County General Fund	Tax Roll	Adjustments	Adjusted Tax Roll	Current Tax Collected	Penalty & Interest Collected	Variance	Uncollected Balance	YTD Collected	YTD Percent Collected	YTD Percent Collected w/P & I	YTD Percent Collected w/P & I & Prior Years
2017	\$244,690,088.70	\$307,582.16	\$244,997,670.86	\$77,441,846.75	\$5.46	(\$9.23)	\$9,406,482.62	\$235,591,188.24	96.16%	96.16%	96.65%
2016 & Prior Rollbacks	\$1,986,312.80	(\$105,297.51)	\$1,881,015.29	\$74,472.35	\$29,191.29	\$16.21	\$1,591,840.86	\$289,174.43	15.37%	20.73%	
	\$288,563.47	\$552,315.73	\$840,879.20	\$471,982.64	\$0.00	(\$0.18)	\$23,197.33	\$817,681.87	97.24%	97.24%	
Total All	\$246,964,964.97	\$754,600.38	\$247,719,565.35	\$77,988,301.74	\$29,196.75	\$6.80	\$11,021,520.81	\$236,698,044.54	95.55%	95.59%	

Williamson County RFM	Tax Roll	Adjustments	Adjusted Tax Roll	Current Tax Collected	Penalty & Interest Collected	Variance	Uncollected Balance	YTD Collected	YTD Percent Collected	YTD Percent Collected w/P & I	YTD Percent Collected w/P & I & Prior Years
2017	\$22,761,673.50	\$31,550.51	\$22,793,224.01	\$7,230,494.73	\$0.50	(\$1.76)	\$863,686.26	\$21,929,537.75	96.21%	96.21%	96.68%
2016 & Prior Rollbacks	\$168,664.29	(\$8,740.88)	\$159,923.41	\$6,823.92	\$2,574.36	\$1.25	\$132,781.62	\$27,141.79	16.97%	22.64%	
	\$25,120.98	\$48,830.48	\$73,951.46	\$41,429.21	\$0.00	(\$0.02)	\$2,085.69	\$71,865.77	97.18%	97.18%	
Total All	\$22,955,458.77	\$71,640.11	\$23,027,098.88	\$7,278,747.86	\$2,574.86	(\$0.53)	\$998,553.57	\$22,028,545.31	95.66%	95.70%	

2017 COMBINED MONTHLY BREAKDOWN

Oct-17	\$269,920,423.74	\$553,492.70	\$270,473,916.44	\$9,831,927.33	\$37,739.92	\$564.42	\$260,641,424.69	\$9,832,491.75			
Nov-17	\$270,473,916.44	\$412,042.93	\$270,885,959.37	\$11,909,015.73	\$18,907.00	\$570.67	\$249,143,881.22	\$21,742,078.15			
Dec-17	\$270,885,959.37	(\$14,649.56)	\$270,871,309.81	\$151,714,891.47	\$21,384.35	\$2,564.36	\$97,411,775.83	\$173,459,533.98			
Jan-18	\$270,871,309.81	(\$124,645.58)	\$270,746,664.23	\$85,267,049.60	\$31,771.61	\$6.27	\$12,020,074.38	\$258,726,589.85			

**Year to Date Collection Report
October 1 - January 31, 2018**

■ YTD Collected ■ YTD Uncollected

GWI

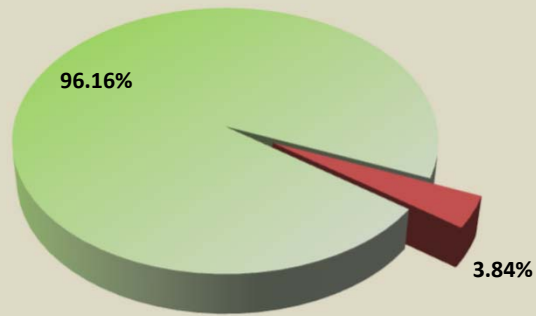

**Year to Date Collection Report
October 1 - January 31, 2018**

■ YTD Collected ■ YTD Uncollected

RFM

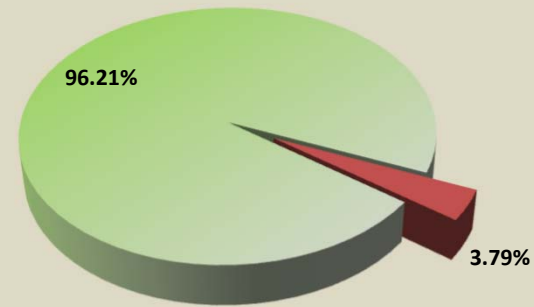

**Percent of Roll Collected Comparison
January 2014-2018**

GWI

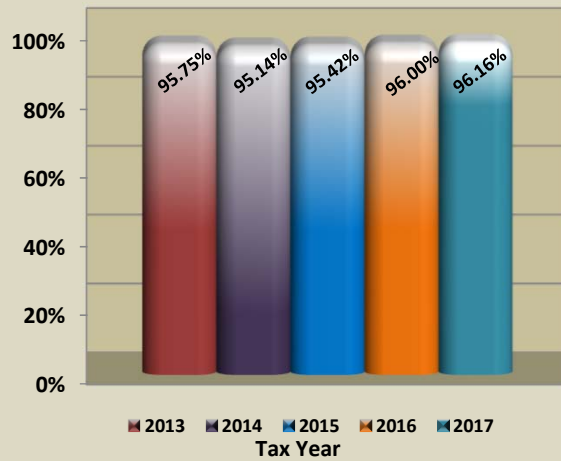

**Percent of Roll Collected Comparison
January 2014-2018**

RFM

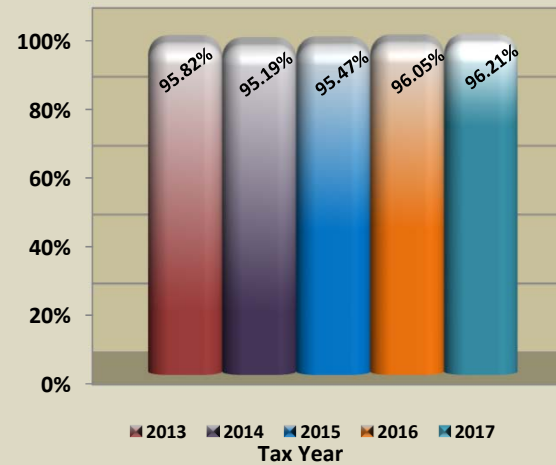

Commissioners Court - Regular Session

11.

Meeting Date: 02/27/2018

Property Tax Refunds - Over 2500 - January 2018

Submitted For: Larry Gaddes

Submitted By: Cathy Atkinson, County Tax Assessor Collector

Department: County Tax Assessor Collector

Agenda Category: Consent

Information

Agenda Item

Discuss, consider and take appropriate action on approving property tax refunds over \$2,500.00 for the month of January 2018 for the Williamson County Tax Assessor/Collector.

Background

Fiscal Impact

From/To	Acct No.	Description	Amount
---------	----------	-------------	--------

Attachments

010118-013118 Refunds Over 2500

Form Review

Inbox

County Judge Exec Asst.

Form Started By: Cathy Atkinson

Final Approval Date: 02/21/2018

Reviewed By

Wendy Coco

Date

02/21/2018 04:25 PM

Started On: 02/15/2018 04:04 PM

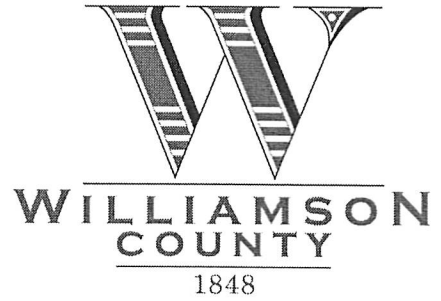

Date: February 15, 2018
To: Members of the Commissioners Court
From: Larry Gaddes PCAC, CTA
Subject: Property Tax Refunds

Larry Gaddes PCAC, C T A
Tax Assessor/Collector

In accordance with Section 31.11 of the Property Tax Code, the court needs to approve all refunds in excess of \$2,500.00. We are presenting the attached list which includes these property tax refunds for your approval.

Please contact me at (512) 943-1954, if you have any questions.

Thank you.

Main Office and Mailing Address:

904 South Main Street
Georgetown, Texas 78626
Motor Vehicle Telephone: 512.943.1602
Property Tax Telephone: 512.943.1603
www.wilco.org/tax

1801 E. Old Settler's Blvd., Ste 115
Round Rock, Texas 78664
Telephone: 512.244.8644

Annex Locations:

350 Discovery Blvd., Ste. 101
Cedar Park, Texas 78613
Telephone: 512.260.4290

412 Vance St., Ste. 1
Taylor, Texas 76574
Telephone: 512.352.4140

Property Tax
Account QuickReport
As of January 31, 2018

Type	Date	Num	Name	Memo	Amount
Check	01/03/2018	64423	STANFORD S OR LINDA TEW FADER	R414490 - Double payment	-2,759.48
Check	01/03/2018	64429	CENLAR	R518770 - Overpayment	-4,171.37
Check	01/09/2018	64450	WILLIAM OR STEPHANIE HENDRIX	Multiple Accounts - Overpayment	-9,616.53
Check	01/09/2018	64457	AVERY KADISON	R417294 - Overpayment	-2,750.00
Check	01/09/2018	64460	ANAND AND KUMUDAVALLI VALLAMSETLA	R479802 - Double payment	-11,115.64
Check	01/09/2018	64463	RICHARD GRABISH	R401834 - Overpayment	-6,996.50
Check	01/09/2018	64466	CYNTHIA BERNAL	R507637 - Double payment	-3,574.20
Check	01/10/2018	64469	DANNY & CHERIE SPIVEY	R517562 - Double payment	-5,070.99
Check	01/18/2018	64572	M/I TITLE LLC	Multiple Accounts - Overpayments	-2,511.62
Check	01/18/2018	64576	PLANET HOME LENDING	R515781 - Overpayment	-5,609.22
Check	01/18/2018	64578	FIRST UNITED BANK	Multiple Accounts - Overpayments	-26,237.84
Check	01/18/2018	64598	PENNY MAC	Multiple Accounts - Double payments	-8,929.31
Check	01/18/2018	64601	TEXAS LAND FUND NO 6 LP	Multiple Accounts - Double payment	-8,683.82
Check	01/18/2018	64603	MAXCOM SECURITIES INC	R546790 - Double payment	-5,213.68
Check	01/18/2018	64613	NISHA AGRAWAL	R540326 - Overpayment	-12,741.15
Check	01/18/2018	64615	VENKATA GOLLAPUDI	R529590 - Double payment	-11,052.65
Check	01/22/2018	64618	ANAND ILANGO	R520734 - Overpayment	-9,999.00
Check	01/22/2018	64620	BARRY HYDO	R543107 - Overpayment	-8,000.00
Check	01/22/2018	64621	BARRY HYDO	R466484 - Overpayment	-2,529.51
Check	01/22/2018	64623	CORELOGIC TAX SERVICES, LLC	Multiple Accounts - Over & Double payments	-383,913.41
Check	01/22/2018	64625	JNC DEVELOPMENT INC	Multiple Accounts - Double payments	-10,951.47
Check	01/22/2018	64634	BIDA CHEN	R372934 - Overpayment	-7,800.00
Check	01/22/2018	64635	KAMBIZ JAHADI	R358223 - Overpayment	-7,400.00
Check	01/22/2018	64636	MAHESH TODKAR OR VARSHA TAMGAVE	R506297 - Overpayment	-10,000.00
Check	01/22/2018	64637	QINGDE WANG OR MI DONG	R529602 - Overpayment	-11,000.00
Check	01/22/2018	64638	RAMESH RAMANI OR ARCHANA K RAO	R506314 - Overpayment	-7,000.00
Check	01/22/2018	64639	JAY OR HEATHER MASON	R470601 - Overpayment	-8,700.00
Check	01/22/2018	64640	NATARAJAN ANNAMALAI OR BHARATHY NATARAJAN	R520651 - Overpayment	-10,500.00
Check	01/22/2018	64641	SAURABH OR VINI P GUPTA	Multiple Accounts - Overpayments	-12,000.00
Check	01/22/2018	64642	BERNARD ROBINSON	Multiple Accounts - Overpayments	-21,282.02
Check	01/22/2018	64643	VIKAS VASISHT OR CHINMAYIE D VASISHT	R520751 - Overpayment	-10,116.00
Check	01/22/2018	64644	DENNIS OR SHARON PRATT	R483179 - Overpayment	-2,585.35

Property Tax
Account QuickReport
As of January 31, 2018

Type	Date	Num	Name	Memo	Amount
Check	01/22/2018	64645	MINH TRAN OR KIM B NGUYEN	R525050 - Overpayment	-7,000.00
Check	01/22/2018	64646	ROBERT OR SANDEE LAMBERT	R518176 - Overpayment	-8,773.71
Check	01/22/2018	64647	BALASUBRAMANIAN SIVASUBRAMANIAN	R529582 - Overpayment	-6,000.00
Check	01/22/2018	64648	GANESH AND SIVA LAKSHMI BOTLA	R533377 - Double payment	-11,000.00
Check	01/22/2018	64649	LIANG WANG	R466641 - Double payment	-10,000.00
Check	01/22/2018	64650	SOMASEKHAR B & DEEPIKA MAHANTHESH ATLURI	R529870 - Double payment	-7,528.11
Check	01/22/2018	64651	JERRY SULLIVAN	R491195 - Double payment	-11,000.00
Check	01/22/2018	64652	NAVEEN KUMAR GAJAVADA	R527942 - Double payment	-10,900.00
Check	01/22/2018	64653	DIVYANSU D & FALGUNI J PATEL	R304242 - Double payment	-6,300.00
Check	01/22/2018	64654	DAVID & CHRISTINA SCHWERDTFEGGER	R515996 - Double payment	-10,800.00
Check	01/22/2018	64655	ANURANJAN GULATI	R498413 - Double payment	-15,000.00
Check	01/22/2018	64656	SIDHI VEERESHAM KANDUKURI	R528010 - Double payment	-7,500.00
Check	01/22/2018	64658	VINEETHA SHENOY	R479201 - Double payment	-7,226.15
Check	01/22/2018	64659	KARTIK PATEL	R511313 - Double payment	-11,250.43
Check	01/22/2018	64660	KEITH AND DAVID HAWLEY	R471211 - Double payment	-7,144.80
Check	01/22/2018	64661	NATALIA BROOKS	R427598 - Double payment	-7,633.36
Check	01/22/2018	64662	JIANWEN SUN	R391217 - Double payment	-7,224.93
Check	01/22/2018	64666	GRAYSTONE TITLE COMPANY LLC	R405196 - Overpayment	-31,390.13
Check	01/22/2018	64668	NATIONSTAR MORTGAGE LLC	Multiple Accounts - Double payments	-14,427.31
Check	01/25/2018	64687	PRASHANTH R KONDA	R487679 - Double payment	-8,055.71
Check	01/25/2018	64688	RAMESH CHANDRA BANAIYA	R538430 - Double payment	-5,000.00
Check	01/25/2018	64694	SANTA RITA KC, LLC.	Multiple Accounts - Double payments	-3,590.92
Check	01/25/2018	64696	AUSTIN TITLE COMPANY	R102946 - Overpayment	-3,812.65
Check	01/25/2018	64704	WENDY K OR MICHAEL M MOOSAVI	R549615 - Overpayment	-4,000.00
Check	01/25/2018	64713	WILLIAMSON COUNTY TAX OFFICE	R448360 - Overpayment - Pay back	-5,972.08
Check	01/25/2018	64715	CENLAR	Multiple Accounts - Double payments	-50,359.14
Check	01/25/2018	64717	SWEET TOOTH CANDY & CAFE	P478445 - Overpayment	-4,439.71
Check	01/25/2018	64719	LUKE OR NINA SEDDELMAYER	R546621 - Overpayment	-11,000.00
Check	01/25/2018	64720	JIDONG WANG	R511026 - Overpayment	-11,453.00
Check	01/25/2018	64730	DAVID STEPHEN OR MARY COCO	R091702 - Overpayment	-5,316.81
Check	01/25/2018	64731	ROD OR JESSICA F PADDOCK	R492835 - Overpayment	-5,000.00
Check	01/25/2018	64736	AIHUA DONG	R340350 - Double payment	-6,747.06
Check	01/25/2018	64737	NORMA YAU-CHEE LEBEN	R063754 - Double payment	-4,256.69

**Property Tax
Account QuickReport**
As of January 31, 2018

Type	Date	Num	Name	Memo	Amount
Check	01/25/2018	64738	NANCY P & MAURY P & BRIAN L TARVIN	R359069 - Double payment	-3,196.56
Check	01/25/2018	64745	FREDRICKSON BUILDERS II LTD	Multiple Accounts - Double payments	-9,376.33
Check	01/25/2018	64748	CLAUDIA WAGNER	R305529 - Overpayment	-2,500.00
Check	01/25/2018	64749	TERESA T VO	R423437 - Double payment	-6,970.82
Check	01/25/2018	64751	OLD TAYLOR HIGH	Multiple Accounts - Double payments	-13,698.90
Check	01/25/2018	64754	LYDA HOLDINGS LLC	R009919 - Double payment	-10,271.85
Check	01/25/2018	64763	DAVOUD OR AFSON SAFARI	R099044 - Overpayment	-13,000.00
Check	01/26/2018	64780	KAREN OR GARY FIERST	R518144 - Overpayment	-17,641.09
Check	01/30/2018	64789	HARRY GEORGE OR GWENDOLYN E DUNN	R358887 - Double payment	-2,966.39
Total Refunds Payable - Taxpayers					-1,057,535.40
					<u>-1,057,535.40</u>

Commissioners Court - Regular Session

12.

Meeting Date: 02/27/2018

indigent

Submitted By: Rebecca Clemons, County Judge

Department: County Judge

Agenda Category: Consent

Information

Agenda Item

Discuss, consider and take any necessary action to approve order for interment of deceased Williamson County resident (James H. Coward) where there has been no inquest by the Justice of the Peace and the county has duty to inter, pursuant to Tex. Health & Safety Code § 711.002(e), and authorize Beck Funeral Home to move forward with interment.

Background

Fiscal Impact

From/To	Acct No.	Description	Amount
---------	----------	-------------	--------

Attachments

order

hospice

Form Review

Inbox

County Judge Exec Asst. (Originator)
Form Started By: Rebecca Clemons
Final Approval Date: 02/21/2018

Reviewed By

Wendy Coco

Date

02/21/2018 04:25 PM
Started On: 02/21/2018 11:47 AM

STATE OF TEXAS §
 §
COUNTY OF WILLIAMSON §

**ORDER OF COMMISSIONERS COURT
OF WILLIAMSON COUNTY, TEXAS
AUTHORIZING INTERMENT
OF DECEDENT’S REMAINS**

Pursuant to the Laws and Rules of the State of Texas, the Texas Health & Safety Code, Chapter 711, Section 711.002(e), and the common law granting the County authority to regulate the public health and safety, the Commissioners Court of Williamson County finds that:

Williamson County resident, James H. Coward (SSN xxx-xx-9660) passed away on February 16, 2018 at the age of 75 with residence at 901 Discovery Blvd., Cedar Park, TX 78613.

The Court further finds that there have been numerous attempts to contact all known next of kin, but all attempts to communicate with the deceased’s family have failed to identify any known next of kin. Additionally, the deceased spent time in local hospice care without visitors and has been abandoned. An asset search has revealed no significant property of any kind.

The Court further finds that there has been no inquest ordered in this case, and there is no person with duty to inter as set forth in Chapter 711 of the Texas Health & Safety Code; therefore, the duty to inter the remains falls to Williamson

County.

IT IS THEREFORE ORDERED THAT the deceased body shall be interred (*i.e.*, permanent disposition of remains by cremation, entombment, burial, or placement in a niche).

IT IS THEREFORE ORDERED THAT Beck Funeral Home LTD is granted authority to cremate the deceased.

Signed and entered this _____ day of February, 2018.

Hon. Dan Gattis
Williamson County Judge

FACE SHEET

Sagebrook S N Health Center

JAMES H COWARD Preferred Name: JAMES 901 DISCOVERY BLVD CEDAR PARK, TX 78613	Res No.: 583 Loc: 3 313 B Ph: (512) 797-9571 Sex: M	Admit Date: 4/11/17 3:00 pm ReAdmitted: Discharged: Discharge Status: D.O.B.: 2/1943	Admitted From: Readmitted From: Discharged To: SSN: ██████████-9660
--	--	--	--

MEDICAL INFORMATION

Med Record no: 583 Height: 65 in. Admit Weight: 142.2 lbs. Primary Phys: FRY, LIAM (512) 477-4088 1108 Lavaca Street Austin, TX 78701 Alternate Phys: Referring Phys: QL Hospital stay: CEDAR PARK REGIONAL ME From/Thru: 2/14/17 thru 2/24/17 Rehab Potential:	Allergies: cyclobenzaprine	Admit Dx: K51.00 Ulcerative (chronic) pancolitis without complications Discharge Dx: Current Dx: I10 Essential (primary) hypertension N31.9 Neuromuscular dysfunction of bladder, unspecified I50.21 Acute systolic (congestive) heart failure E03.9 Hypothyroidism, unspecified See next page for additional diagnoses
---	-------------------------------	---

Admitted with: Catheter present Contractures Restraint Orders Pressure Sores (other than Stage 1)

Received pneumococcal vaccine 1/01/09 Received influenza immunization 10/19/16 In facility

<p align="center">DEMOGRAPHICS</p> Marital Status: Widowed County: WILLIAMSON Race: Caucasian Primary Lang: English Religion: None Birthplace: TEXAS Occupation: <input checked="" type="checkbox"/> U.S. Citizen <input type="checkbox"/> Military Srv.	<p align="center">SERVICE PROVIDERS and PREFERENCES</p> Pharmacy PHARMERICA (512) 443-8984
--	---

<p align="center">BILLING INFORMATION</p> A/R Type: AMC CMG: RAC Resources: 641.00 Medicare #: 464669660A Ancillary A/R Type: MRB Medicaid #: 511023317 Ancillary Co-ins A/R Type: MXB Ins Grp: Pol: Ins Grp: Recurring Room Chg: <input checked="" type="checkbox"/> Adv Bill <input type="checkbox"/> Resident is Self Responsible TrustFund: <input checked="" type="checkbox"/> Apply Interest <input checked="" type="checkbox"/> Max Balance Reminder	Hospital CEDAR PARK REGIONAL (512) 528-7000 Ambulance ACADIAN (866) 404-0911 Part D Plan: Effective: RxBIN: RxPCN: Cardholder ID: Group No: Issuer:
--	---

<p>RESPONSIBLE PARTY</p> JAMES COWARD 901 DISCOVERY BLVD CEDAR PARK TX 78613 Relationship: Self Phone: (Day) (512) 797-9571 (Eve) (Cell)	<p>SECOND CONTACT</p> BILLY SMOTHERS 2303 W RIVIERA DR CEDAR PARK TX 78613 Relationship: Son Phone: (Day) (512) 797-9571 (Eve) (Cell) (512) 803-8428	<p>THIRD CONTACT</p> BOBBY SMOTHERS Relationship: Son Phone: (Day) (512) 797-9571 (Eve) (Cell) (512) 897-3502
---	---	--

ADDITIONAL INFORMATION

LAUNDRY WILL BE DONE BY:	FAMILY
BPCI Working DRG	391
BPCI Final DRG	871

Commissioners Court - Regular Session

13.

Meeting Date: 02/27/2018

CAHFC Bonds Stillwater

Submitted For: Dan Gattis

Submitted By: Hal Hawes, County Judge

Department: County Judge

Agenda Category: Consent

Information

Agenda Item

Discuss, consider and take appropriate action authorizing the County Judge to execute a Certificate of Approval relating to the Capital Area Housing Finance Corporation’s Multifamily Housing Revenue Bonds for the Residences at Stillwater Apartments Project.

Background

This certificate is solely for the purposes of the approval requirements of Section 147(f) of the IRC. Since project is located in Williamson County, Texas (the “County”), Section 147(f) of the Internal Revenue Code states that the “highest elected official” of the jurisdiction containing the project site must approve the transaction after a public hearing is held. Bond counsel is now seeking the approval of the highest elected public official for this jurisdiction. The loan will not be a debt or liability of the County. The consent being requested herein is only for the purposes of complying with the federal tax law regarding tax-exempt financing.

Fiscal Impact

From/To	Acct No.	Description	Amount
---------	----------	-------------	--------

Attachments

[CAHFC Letter and Certif of Approval](#)

Form Review

Inbox

County Judge Exec Asst.
Form Started By: Hal Hawes
Final Approval Date: 02/21/2018

Reviewed By

Wendy Coco

Date

02/21/2018 04:25 PM
Started On: 02/15/2018 02:41 PM



February 6, 2018

The Honorable Dan A. Gattis
Williamson County Judge
Williamson County Courthouse
710 S. Main Street, Suite 101
Georgetown, Texas 78626

Re: Capital Area Housing Finance Corporation
Multifamily Housing Revenue Bonds
(Residences of Stillwater Apartments) (the “Bonds”)

Dear Judge Gattis:

The Capital Area Housing Finance Corporation (the “Corporation”) intends to issue the above-captioned Bonds in order to provide funds to finance the cost of a residential development that will provide decent, safe and sanitary housing at affordable prices for residents within the Corporation’s jurisdiction. The Bonds will be special limited obligations of the Corporation payable solely from the collateral pledged to secure the Bonds. The sponsoring local political subdivisions of the Corporation are not in any way liable for the payment of the Bonds.

In connection with the issuance by the Corporation of the Bonds, enclosed herewith are three (3) copies of the Certificate of Approval (the “Approval”) for execution by you as the County Judge of the County of Williamson. I have included below for your convenience a description of the legal requirements behind the Approval.

The Approval is required by Section 147(f) of the Internal Revenue Code of 1986, as amended (the “Code”). The Code requires that you, as the chief elected executive officer of the County of Williamson and “applicable elected representative” thereof, approve the issuance of the Bonds after a public hearing following reasonable public notice. The Corporation conducted a public hearing on December 22, 2017 at the Round Rock Public Library (the “Public Hearing”). A notice for the Public Hearing was published in the *Austin American-Statesman* on December 7, 2017. The minutes of the Public Hearing are enclosed.

Please review the Approval and call me at (512) 349-9104 with any questions or comments you may have. Otherwise, if all is in order, please execute all three (3) signature pages for the Approval and return them to Chapman and Cutler LLP, Bond Counsel to the Corporation, using the enclosed prepaid Federal Express envelope at your convenience.

CAPITAL AREA HOUSING FINANCE
CORPORATION

By 

M. John Trofa
General Counsel

Enclosure

cc: Jim Shaw, Executive Director of Capital Area HFC

**CERTIFICATE OF APPROVAL
FOR ISSUANCE OF TAX-EXEMPT MULTIFAMILY HOUSING REVENUE BONDS**

I, the chief elected executive officer of Williamson County, Texas, elected at-large by the voters of Williamson County, Texas, make this certificate solely to satisfy the requirements of Section 147(f) of the Internal Revenue Code of 1986, as amended, with respect to the proposed issuance of a series of tax-exempt multifamily housing revenue bonds by the Capital Area Housing Finance Corporation in an aggregate face amount of not more than \$30,000,000 (Residences of Stillwater Apartments) (the "*Bonds*"). The Bonds will be issued for the benefit of Pedcor Investments-2017-CLXVII, L.P., or an affiliate thereof (the "*Borrower*"), in connection with the construction of an approximately 192-unit multifamily development located at 1500 block of NE Inner Loop, Georgetown, Texas 78626 (the "*Development*"). The Borrower will own the Development and the land on which the Development is to be constructed.

A public hearing was held on behalf of Williamson County, by James E. Shaw, the designated hearing officer, as described in the attached Certificate of Hearing Officer. As the "applicable elected representative" of Williamson County, Texas, I approve the issuance of the Bonds in the amount and for the purpose described above.

This approval is not: (1) a warranty by Williamson County, Texas, the County Judge of Williamson County, Texas, or of any agency, political subdivision, or instrumentality of the State of Texas that the Bonds will be paid or that any of the obligations assumed in connection with issuance of the Bonds will in fact be performed; (2) a pledge of the faith and credit of the State of Texas or of any agency, political subdivision, or instrumentality the State of Texas; or (3) a warranty of the validity of the corporate existence of the Capital Area Housing Finance Corporation or of the Bonds themselves.

IN WITNESS WHEREOF, I have officially signed my name in the City of Georgetown, Williamson County, Texas, on the date set forth below.

Dan A. Gattis, County Judge
Williamson County, Texas

Dated: _____, 2018

CERTIFICATE OF HEARING OFFICER

I, the undersigned, acting as hearing officer (the "*Hearing Officer*"), do hereby make and execute this certificate for the benefit of all persons interested in the proposed Capital Area Housing Finance Corporation Multifamily Housing Revenue Bonds (Residences at Stillwater), Series 2018 to be issued in a principal amount not to exceed \$30,000,000 (the "*Bonds*") for the benefit of Pedcor Investments-2017-CLXVII, L.P., or an affiliate thereof, in connection with the acquisition, construction and equipping of an approximately 192-unit multifamily development located at 1500 block of NE Inner Loop, Georgetown, Texas 78626 (the "*Development*").

I hereby certify as follows:

1. That I am the duly appointed Hearing Officer for the public hearing that was held on December 22, 2017, at 1:00 p.m. at the Round Rock Public Library, Room B, 216 E. Main Street, Round Rock, Texas 78664, in connection with the issuance of the Bonds.

2. That notice of the public hearing was published no less than 14 days before the date of the public hearing in a newspaper or newspapers of general circulation available to residents of Williamson County, Texas, as described in *Exhibit A* attached hereto; the notice included the date, time and place of the public hearing, the location, a description of the Development and the maximum aggregate principal amount of the Bonds.

3. That all interested persons appearing at the public hearing were given an opportunity to comment on the proposed issuance of the Bonds and the Development. The names and comments of all interested persons appearing at the public hearing, if any, are set forth in *Exhibit A* attached hereto.

4. That after giving all interested persons an opportunity to appear and comment, the public hearing was declared closed.

5. That a copy of the Affidavit of Publication of Notice of Public Hearing is set forth in *Exhibit B* attached hereto.

[Remainder of Page Intentionally Left Blank]

WITNESS MY HAND this 16th day of January, 2018.



James E. Shaw, Hearing Officer

EXHIBIT A

MINUTES OF PUBLIC HEARING

A public hearing was held by the Capital Area Housing Finance Corporation (the "Issuer") at Round Rock Public Library, Room B, 216 E. Main Street, Round Rock, Texas 78664, on December 22, 2017, beginning at 1:00 p.m.

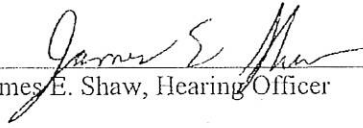
The hearing was held with respect to the proposed issuance by the Issuer of not to exceed \$30,000,000 of its Multifamily Housing Revenue Bonds (Residences at Stillwater), Series 2018 (the "Bonds") in satisfaction of the requirements of Section 147(f) of the Internal Revenue Code of 1986, as amended, regarding the public approval prerequisite to the excludability of the interest on the Bonds from gross income for federal income tax purposes.

The Notices of Public Hearing published in the *Austin American-Statesman* on December 7, 2017 indicated that the proceeds of the Bonds will be used to finance the acquisition, construction and equipping of the Residences at Stillwater Apartments (the "Development"), located within the geographic limits of Williamson County, Texas, by Pedcor Investments-2017-CLXVII, L.P., or an affiliate thereof (the "Borrower").

Present at the hearing on behalf of the Issuer were James E. Shaw, the hearing officer for the Issuer (the "Hearing Officer"), M. John Trofa, general counsel to the Issuer and Jean Latsha of Pedcor Investments, A Limited Liability Company, an affiliate of the Borrower.

The Hearing Officer called the meeting to order and asked if there were any interested persons present who wished to express their views with respect to the issuance of the Bonds, or the Development being financed.

No one expressed an interest to speak.

Whereupon the Hearing Officer closed the public hearing at 1:30 p.m.

EXHIBIT B

AFFIDAVIT OF PUBLICATION OF NOTICE OF PUBLIC HEARING

CHAPMAN & CUTLER LLP
111 WEST MONROE ST
CHICAGO, IL 60603

Invoice/Order Number: 0000269495
Ad Cost: \$663.97
Paid: \$663.97
Balance Due: \$0.00

**CAPITAL AREA HOUSING FINANCE CORPORATION
NOTICE OF PUBLIC HEARING**

In accordance with Section 147(f) of the Internal Revenue Code of 1986, as amended (the "Code"), notice is hereby given that the Capital Area Housing Finance Corporation (the "Corporation") will hold a public hearing at 1:00 p.m. on Friday, December 22, 2017, at at the Round Rock Public Library, Room B, 216 E. Main Street, Round Rock, Texas 78664. The Corporation's designated hearing officer will conduct the hearing on behalf of the Texas Counties of Bastrop, Blanco, Burnet, Caldwell, Fayette, Hays, Lee, Llano, Williamson and the Texas City of San Marcos (the "Sponsoring Political Subdivisions").

The purpose of the hearing is to provide residents of the Sponsoring Political Subdivisions an opportunity to comment on the proposed issuance by the Corporation of its Multifamily Housing Revenue Bonds to be issued in one or more series (the "Bonds") in an aggregate face amount of not more than \$30,000,000. The Bonds will be issued for the benefit of Pedcor Investments-2017-CLXVII, L.P., or an affiliate thereof (the "Borrower"), in connection with the acquisition, construction and equipping of a multifamily housing development to be located at the 1500 block of NE Inner Loop, Georgetown, Texas 78626 and consisting of approximately 192 units (the "Development"). The Borrower will own the Development and the land on which the Development will be situated.

The Bonds will be limited obligations of the Corporation, payable solely from the revenues, receipts and resources of the Corporation pledged to their payment. The Bonds will not constitute an indebtedness or obligation of any of the Sponsoring Political Subdivisions (or any other city, county or other municipal or political corporation or subdivision of the State of Texas) or of the State of Texas, or a loan of credit of any of them, within the meaning of any constitutional or statutory provision.

All interested persons are invited to attend the hearing and present written or oral comments on the proposed issuance of the Bonds. Questions or written comments prior to the date of the hearing may be directed to the Capital Area Housing Finance Corporation, 4101 Parkstone Heights Drive, Suite 280, Austin, Texas 78746. Attention: James E. Shaw at (512) 347-9953.

12-7-2017
0000269495-01

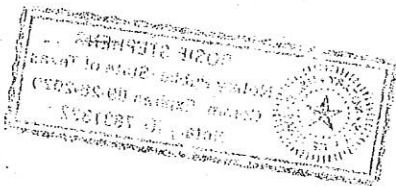

Commissioners Court - Regular Session

14.

Meeting Date: 02/27/2018

North Campus Facility P324 - Change Order 27

Submitted By: Gina Wrehsnig, Infrastructure

Department: Infrastructure

Division: Building Maintenance

Agenda Category: Consent

Information

Agenda Item

Discuss, consider and take appropriate action on accepting and approving a report on the Williamson County North Campus Project; Change Order #27 in the amount of \$2,687.00 for additional roller shades and a credit for window blinds, which was executed by Dwayne Gossett, Williamson County Facilities Project Manager, pursuant to the previous grant of authority under Section 262.031 of the Local Government Code. This change order is being funded out of the Owners Contingency.

Background

On September 6, 2016, the Williamson County Commissioners Court granted Dwayne Gossett, Williamson County Facilities Project Manager, with general authority to approve change orders for the Agreement for Construction Services with J. T. Vaughn Construction, LLC in relation to the Williamson County North Campus Project for any increase in costs up to a total maximum amount of \$30,000.00 in accordance with Section 262.031 of the Local Government Code – Changes in Plans and Specifications. This report is being provided for purposes of notifying the court of such change order and to place it in the minutes of the Commissioners Court.

Fiscal Impact

From/To	Acct No.	Description	Amount
---------	----------	-------------	--------

Attachments

[NCF Change Order 27](#)

[NCF CO27 Funds](#)

Form Review

Inbox

County Judge Exec Asst.

Form Started By: Gina Wrehsnig

Final Approval Date: 02/22/2018

Reviewed By

Wendy Coco

Date

02/22/2018 08:28 AM

Started On: 02/22/2018 07:49 AM



3171 SE Inner Loop
Georgetown, TX
78626

T: (512) 663-7461
F: (512) 681-9752

February 10, 2018

Dwayne Gossett
Williamson County, Texas
3101 SE Inner Loop
Georgetown, TX 78620

Re: North Campus Facilities
Job No: 233901

Subj: Change Proposal No. 233901-0027

Dear Sir or Madam:

We respectfully submit our proposal for an increase to our contract in the amount of \$0 (zero) dollars to provide Additional Roller Shades in Rooms h104, h107, h112 and h236 for the above referenced project.

Our price is valid for Ten (10) days

Please indicate your acceptance of this change proposal by signing and returning one copy of the attached Form B breakdown of our cost.

Very truly yours,
VAUGHN CONSTRUCTION

A handwritten signature in blue ink, appearing to read "Doug Boram".

Doug Boram

Attachments: Form B, Subcontractor Pricing Back-up

CC: Brody Harris - BLGY
Mark Brown - BLGY

FORM B

PROJECT: North Campus Facilities

CHANGE PROPOSAL NO: 233901-0027

QUOTATION :

<u>Item</u>	<u>Labor</u>	<u>Materials</u>	<u>Subs</u>	<u>Total</u>
Additional Roller Shades in Rooms h104, h107 and h236	\$0.00	\$0.00	\$2,940.00	\$2,940.00
Deduct to Remove Blinds in Room h104, h107, and h236	\$0.00	\$0.00	\$(756.00)	\$(756.00)
To Be Funded By Owners Contingency	\$0.00	\$(2,687.00)	\$0.00	\$(2,687.00)
Additional Roller Shades in Room h112	\$0.00	\$0.00	\$680.00	\$680.00
Deduct to Remove Blinds in Room h112	\$0.00	\$0.00	\$(177.00)	\$(177.00)

Totals	\$0.00	\$(2,687.00)	\$2,687.00	\$0.00
				Insurance, Tax, Benefits on Labor
				\$0.00
				Overhead
				\$0.00
				Fee on Subs
				\$0.00
				Fee on JTV
				\$0.00
				Bond
				\$0.00
				Remodel Tax
				\$0.00
TOTAL				\$0.00

TIME EXTENSION TO CONTRACT: 0 Days

Submitted Date: 2/10/2018

Accepted

VAUGHN CONSTRUCTION

By: 

By: 
Doug Boram

Date _____

Proposal Valid for 10 Days

Williamson County
 Williamson County North Campus Facilities
 Vaughn Project No. 2339-01



Funds Tracking Log

Change Proposal No.	Change Type & No.	Time Extension (Days)		GMP Breakdown						GMP #2339.01	Total Updated Contract Amount
		Pending	Approved	Cost of Work	CM Contingency	Owner Contingency	General Conditions	Buyout Savings	Construction Phase Fee		
N/A	GMP	-	-	\$18,195,395	\$406,771	\$406,772	\$1,896,522		\$625,467	\$21,530,927	\$21,530,927
1	OCO	0	0	\$3,659	\$0	(\$3,659)	\$0		\$0	\$0	\$21,530,927
2	OCO	10	10	\$114,186	\$0	(\$114,186)	\$0		\$0	\$0	\$21,530,927
3	OCO	0	0	\$1,727	\$0	(\$1,748)	\$21		\$0	\$21	\$21,530,948
4	OCO	0	0	\$19,494	\$0	(\$19,494)	\$0		\$0	\$0	\$21,530,948
5	OCO	0	0	\$19,676	(\$19,676)	\$0	\$0		\$0	\$0	\$21,530,948
6	OCO	0	0	\$14,465	(\$14,465)	\$0	\$0		\$0	\$0	\$21,530,948
7	OCO	0	0	\$2,237	\$0	(\$2,237)	\$0		\$0	\$0	\$21,530,948
8	OCO	0	0	\$3,450	\$0	(\$3,450)	\$0		\$0	\$0	\$21,530,948
9	OCO	0	0	\$832	\$0	(\$832)	\$0		\$0	\$0	\$21,530,948
10	OCO	0	0	\$285	\$0	(\$285)	\$0		\$0	\$0	\$21,530,948
11	OCO	0	0	\$22,415	\$0	(\$22,415)	\$0		\$0	\$0	\$21,530,948
12	OCO	0	0	\$11,221	\$0	(\$11,221)	\$0		\$0	\$0	\$21,530,948
13	OCO	0	0	(\$5,000)	\$0	\$5,000	\$0		\$0	\$0	\$21,530,948
14	OCO	0	0	\$0	\$0	\$0	\$0		\$0	\$0	\$21,530,948
15	OCO	0	0	\$79,584	\$0	(\$79,584)	\$0		\$0	\$0	\$21,530,948
16	OCO	0	0	\$9,930	\$0	(\$9,930)	\$0		\$0	\$0	\$21,530,948
17	OCO	0	0	\$2,450	(\$2,450)	\$0	\$0		\$0	\$0	\$21,530,948
18	OCO	0	0	\$1,747	(\$1,747)	\$0	\$0		\$0	\$0	\$21,530,948
19	OCO	0	0	(\$1,763)	\$0	\$0	\$1,763		\$0	\$0	\$21,530,948
20	OCO	0	0	\$5,784	\$0	(\$5,856)	\$72		\$0	\$72	\$21,531,020
21	OCO	0	0	\$10,364	(\$10,364)	\$0	\$0		\$0	\$0	\$21,531,020
22	OCO	0	0	\$6,410	(\$6,461)	\$0	\$51		\$0	\$0	\$21,531,020
23	OCO	0	0	\$15,825	(\$15,825)	\$0	\$0		\$0	\$0	\$21,531,020
24	OCO	0	0	\$33,487	(\$33,906)	\$0	\$419		\$0	\$0	\$21,531,020
25	OCO	0	0	\$8,854	(\$8,854)	\$0	\$0		\$0	\$0	\$21,531,020
26	OCO	0	-	(\$106)	\$0	\$106	\$0		\$0	\$0	\$21,531,020
27R	OCO	0	-	\$2,687	\$0	(\$2,687)	\$0		\$0	\$0	\$21,531,020
Current Amounts		10	10	\$18,579,295	\$293,023	\$134,294	\$1,898,848	\$0	\$625,467	\$21,362,770	\$21,362,770



89 Robert Stevens Drive
Schertz, Texas 78154
www.nextgenerationwc.com

Phone: (210) 858-8934
Fax: (210) 569-6441
Email: cs@nextgenerationwc.com
HUB Certification # 1461745109200
SBE/WBE Certification # 213071251

Authorized Distributor of MechoSystems,
SWF Contract, Hunter Douglas Contract,
Draper and Levolor Contract.

Submitted to: Vaughn Construction
Date: 9/5/2017
Proposal#: 090517A
Project Address: Georgetown, Texas

Project: WILCO - Additional Roller Shades #1

We Hereby Propose To Furnish Materials And Labor Necessary For The Complete Installation Of:

WINDOW H104 & H107
(2) Draper FlexShade Manually Operated Roller Shade With Fascia
Fabric: Avila Twilight Pewter (Blackout, 0% Openness)
Includes Side/Sill Channels

WINDOW H236 (Split Into 3 Shades)
(3) Draper FlexShade Manually Operated Roller Shade With Fascia
Fabric: Avila Twilight Pewter (Blackout, 0% Openness)
Excludes Side/Sill Channels

Includes Standard Option and Controls	Materials	\$ 2,840.00
	Installation	\$ 100.00
	Tax	\$ Excluded
	Total	\$ 2,940.00

Excludes: Wood Blocking. All material is guaranteed to be as specified, and the above work to be performed in accordance with the drawings and specifications submitted for above work and completed in a substantial workmanlike manner. Purchase order or contract required before submittals or ordering may begin. Any alteration or deviation from the above specifications involving extra costs will be executed only upon written orders and will become an extra charge over and above the estimate. All agreements are contingent upon strikes, accidents or delays beyond our control including manufacturer shortages or shipping delays. This proposal may be withdrawn or re-proposed by us if not accepted within 90 days. Accelerated progress payments for stored materials may be required by supplier. A tax exemption certificate is required if project is tax exempt. With payment to be made as follows: Draw Schedule.

Signature Printed Name Date



89 Robert Stevens Drive
Schertz, Texas 78154
www.nextgenerationwc.com

Phone: (210) 858-8934
Fax: (210) 569-6441
Email: cs@nextgenerationwc.com
HUB Certification # 1461745109200
SBE/WBE Certification # 213071251

Authorized Distributor of MechoSystems,
SWF Contract, Hunter Douglas Contract,
Draper and Levolor Contract.

Submitted to: Vaughn Construction
Date: 9/5/2017
Proposal#: 090517B
Project Address: Georgetown, Texas

Project: WILCO - Deduct Miniblinds #1

We Hereby Propose To Furnish Materials And Labor Necessary For The Complete Installation Of:

WINDOW H104 & H107
Delete Miniblinds

WINDOW H236
Delete Miniblinds

Includes Standard Option and Controls	Materials	\$ (756.00)
	Installation	\$ N/A
	Tax	\$ Excluded
	Total	\$ (756.00)

Excludes: Wood Blocking. All material is guaranteed to be as specified, and the above work to be performed in accordance with the drawings and specifications submitted for above work and completed in a substantial workmanlike manner. Purchase order or contract required before submittals or ordering may begin. Any alteration or deviation from the above specifications involving extra costs will be executed only upon written orders and will become an extra charge over and above the estimate. All agreements are contingent upon strikes, accidents or delays beyond our control including manufacturer shortages or shipping delays. This proposal may be withdrawn or re-proposed by us if not accepted within 90 days. Accelerated progress payments for stored materials may be required by supplier. A tax exemption certificate is required if project is tax exempt. With payment to be made as follows: Draw Schedule.

Signature _____ Printed Name _____ Date _____



89 Robert Stevens Drive
Schertz, Texas 78154
www.nextgenerationwc.com

Phone: (210) 858-8934
Fax: (210) 569-6441
Email: cs@nextgenerationwc.com
HUB Certification # 1461745109200
SBE/WBE Certification # 213071251

Authorized Distributor of MechoSystems,
SWF Contract, Hunter Douglas Contract,
Draper and Levolor Contract.

Submitted to: Vaughn Construction
Date: 9/5/2017
Proposal#: 090517A
Project Address: Georgetown, Texas

Project: WILCO - Additional Roller Shades #2

We Hereby Propose To Furnish Materials And Labor Necessary For The Complete Installation Of:

WINDOW H112
(1) Draper FlexShade Manually Operated Roller Shade With Fascia
Fabric: Avila Twilight Pewter (Blackout, 0% Openness)
Excludes Side/Sill Channels

Includes Standard Option and Controls	Materials	\$ 660.00
	Installation	\$ 20.00
	Tax	\$ Excluded
	Total	\$ 680.00

Excludes: Wood Blocking. All material is guaranteed to be as specified, and the above work to be performed in accordance with the drawings and specifications submitted for above work and completed in a substantial workmanlike manner. Purchase order or contract required before submittals or ordering may begin. Any alteration or deviation from the above specifications involving extra costs will be executed only upon written orders and will become an extra charge over and above the estimate. All agreements are contingent upon strikes, accidents or delays beyond our control including manufacturer shortages or shipping delays. This proposal may be withdrawn or re-proposed by us if not accepted within 90 days. Accelerated progress payments for stored materials may be required by supplier. A tax exemption certificate is required if project is tax exempt. With payment to be made as follows: Draw Schedule.

Signature	Printed Name	Date
-----------	--------------	------

NEXT GENERATION WINDOW COVERINGS

89 Robert Stevens Drive
Schertz, Texas 78154
www.nextgenerationwc.com

Phone: (210) 858-8934
Fax: (210) 569-6441
Email: cs@nextgenerationwc.com
HUB Certification # 1461745109200
SBE/WBE Certification # 213071251

Authorized Distributor of MechoSystems,
SWF Contract, Hunter Douglas Contract,
Draper and Levolor Contract.

Submitted to: Vaughn Construction
Date: 9/5/2017
Proposal#: 090517B
Project Address: Georgetown, Texas

Project: WILCO - Deduct Miniblinds #2

We Hereby Propose To Furnish Materials And Labor Necessary For The Complete Installation Of:

WINDOW H112
Delete Miniblind

Includes Standard Option and Controls

(177.00)
N/A
Excluded
(177.00)

Excludes: Wood Blocking. All material is guaranteed to be as specified, and the above work to be performed in accordance with the drawings and specifications submitted for above work and completed in a substantial workmanlike manner. Purchase order or contract required before submittals or ordering may begin. Any alteration or deviation from the above specifications involving extra costs will be executed only upon written orders and will become an extra charge over and above the estimate. All agreements are contingent upon strikes, accidents or delays beyond our control including manufacturer shortages or shipping delays. This proposal may be withdrawn or re-proposed by us if not accepted within 90 days. Accelerated progress payments for stored materials may be required by supplier. A tax exemption certificate is required if project is tax exempt. With payment to be made as follows: Draw Schedule.

Signature

Printed Name

Date

Williamson County Facilities - Job Cost Tracking Log

Project: North Campus Project # P324

Change Order #: 27

Change Order No.	Court Agenda Date	Party of Initiation	Time Ext. (Days)	GMP Breakdown						GMP Total	Total Updated Contract Amount
				Cost of Work	CM Contingency	Owner Contingency	Buyout Savings (Current)	General Conditions	Construction Phase Fee		
Contract				\$ 18,027,145.00	\$ 406,771.00	\$ 406,772.00	\$ -	\$ 1,896,522.00	\$ 625,467.00	\$ 21,362,677.00	\$ 21,362,677.00
1	03/28/17		0	\$ 3,659.00	\$ -	\$ (3,659.00)	\$ -	\$ -	\$ -	\$ -	\$ 21,362,677.00
2	03/28/17		10	\$ 114,186.00	\$ -	\$ (114,186.00)	\$ -	\$ -	\$ -	\$ -	\$ 21,362,677.00
3	05/02/17		0	\$ 1,727.00	\$ -	\$ (1,727.00)	\$ -	\$ -	\$ -	\$ -	\$ 21,362,677.00
4	05/02/17		0	\$ 19,494.00	\$ -	\$ (19,494.00)	\$ -	\$ -	\$ -	\$ -	\$ 21,362,677.00
5	05/30/17		0	\$ 19,676.00	\$ (19,676.00)	\$ -	\$ -	\$ -	\$ -	\$ -	\$ 21,362,677.00
6	05/30/17		0	\$ 14,465.00	\$ (14,465.00)	\$ -	\$ -	\$ -	\$ -	\$ -	\$ 21,362,677.00
7	05/30/17		0	\$ 2,237.00	\$ -	\$ (2,237.00)	\$ -	\$ -	\$ -	\$ -	\$ 21,362,677.00
8	05/30/17		0	\$ 3,450.00	\$ -	\$ (3,450.00)	\$ -	\$ -	\$ -	\$ -	\$ 21,362,677.00
9	06/27/17		0	\$ 832.00	\$ -	\$ (832.00)	\$ -	\$ -	\$ -	\$ -	\$ 21,362,677.00
10	06/27/17		0	\$ 285.00	\$ -	\$ (285.00)	\$ -	\$ -	\$ -	\$ -	\$ 21,362,677.00
11	06/27/17		0	\$ 22,415.00	\$ -	\$ (22,415.00)	\$ -	\$ -	\$ -	\$ -	\$ 21,362,677.00
12	06/27/17		0	\$ 11,221.00	\$ -	\$ (11,221.00)	\$ -	\$ -	\$ -	\$ -	\$ 21,362,677.00
13	06/27/17		0	\$ (5,000.00)	\$ -	\$ 5,000.00	\$ -	\$ -	\$ -	\$ -	\$ 21,362,677.00
14	06/27/17		0	\$ -	\$ -	\$ -	\$ -	\$ -	\$ -	\$ -	\$ 21,362,677.00
15	06/27/17		0	\$ 79,584.00	\$ -	\$ (79,584.00)	\$ -	\$ -	\$ -	\$ -	\$ 21,362,677.00
16	06/27/17		0	\$ 9,930.00	\$ -	\$ (9,930.00)	\$ -	\$ -	\$ -	\$ -	\$ 21,362,677.00
17	09/12/17	A&E	0	\$ 2,450.00	\$ -	\$ -	\$ (2,450.00)	\$ -	\$ -	\$ -	\$ 21,362,677.00
18	09/12/17	A&E	0	\$ 1,747.00	\$ (1,747.00)	\$ -	\$ -	\$ -	\$ -	\$ -	\$ 21,362,677.00
19	09/12/17	Owner	0	\$ 577,128.00	\$ -	\$ -	\$ (577,128.00)	\$ -	\$ -	\$ -	\$ 21,362,677.00
20	12/05/17	A&E	0	\$ 5,784.00	\$ -	\$ (5,856.00)	\$ -	\$ 72.00	\$ -	\$ -	\$ 21,362,677.00
21	10/03/17	A&E	0	\$ 10,364.00	\$ (10,364.00)	\$ -	\$ -	\$ -	\$ -	\$ -	\$ 21,362,677.00
22	10/03/17	A&E	0	\$ 6,461.00	\$ (6,461.00)	\$ -	\$ -	\$ -	\$ -	\$ -	\$ 21,362,677.00
23	12/05/17	A&E	0	\$ 15,825.00	\$ (15,825.00)	\$ -	\$ -	\$ -	\$ -	\$ -	\$ 21,362,677.00
24	10/03/17	A&E	0	\$ 33,906.00	\$ (33,906.00)	\$ -	\$ -	\$ -	\$ -	\$ -	\$ 21,362,677.00
25	10/03/17	A&E	0	\$ 8,854.00	\$ (8,854.00)	\$ -	\$ -	\$ -	\$ -	\$ -	\$ 21,362,677.00
26	02/06/18	A&E	0	\$ (106.00)	\$ -	\$ 106.00	\$ -	\$ -	\$ -	\$ -	\$ 21,362,677.00
27		A&E	0	\$ 2,687.00	\$ -	\$ (2,687.00)	\$ -	\$ -	\$ -	\$ -	\$ 21,362,677.00
28	PENDING REVIEW										\$ 21,362,677.00
29	02/06/18	A&E	0	\$ 3,647.00	\$ (3,647.00)	\$ -	\$ -	\$ -	\$ -	\$ -	\$ 21,362,677.00
30	10/24/17	Contractor		\$ (30,000.00)	\$ -	\$ 30,000.00	\$ -	\$ -	\$ -	\$ -	\$ 21,362,677.00
31	10/24/17	A&E		\$ 4,434.00	\$ -	\$ (4,434.00)	\$ -	\$ -	\$ -	\$ -	\$ 21,362,677.00
32	11/14/17	A&E		\$ 6,816.00		\$ (6,816.00)	\$ -	\$ -	\$ -	\$ -	\$ 21,362,677.00
33	PENDING REVIEW										\$ 21,362,677.00
34	11/14/17	Contractor		\$ 5,273.00	\$ (5,273.00)	\$ -	\$ -	\$ -	\$ -	\$ -	\$ 21,362,677.00
35	PENDING REVIEW										\$ 21,362,677.00
36	12/05/17	A&E	0	\$ 1,280.00	\$ (1,280.00)	\$ -	\$ -	\$ -	\$ -	\$ -	\$ 21,362,677.00
37	12/05/17	A&E	0	\$ 1,601.00	\$ (1,601.00)	\$ -	\$ -	\$ -	\$ -	\$ -	\$ 21,362,677.00
38	PENDING REVIEW										\$ 21,362,677.00
39	PENDING REVIEW										\$ 21,362,677.00
40	PENDING REVIEW										\$ 21,362,677.00
41	02/06/18	Owner	0	\$ (50,311.00)		\$ 50,311.00	\$ -	\$ -	\$ -	\$ -	\$ 21,362,677.00
							\$ -	\$ -	\$ -	\$ -	\$ 21,362,677.00
			10	\$ 18,933,146.00	\$ 283,672.00	\$ 203,376.00	\$ (579,578.00)	\$ 1,896,594.00	\$ 625,467.00	\$ 21,362,677.00	\$ 21,362,677.00

Commissioners Court - Regular Session

15.

Meeting Date: 02/27/2018

North Campus Facility P324 - Change Order 40

Submitted By: Gina Wrehsnig, Infrastructure

Department: Infrastructure

Division: Building Maintenance

Agenda Category: Consent

Information

Agenda Item

Discuss, consider and take appropriate action on accepting and approving a report on the Williamson County North Campus Project; Change Order #40 in the amount of (\$6,292.00) to receive credit for deleted structural concrete, which was executed by Dwayne Gossett, Williamson County Facilities Project Manager, pursuant to the previous grant of authority under Section 262.031 of the Local Government Code. This change order is being credited to the Owners Contingency.

Background

On September 6, 2016, the Williamson County Commissioners Court granted Dwayne Gossett, Williamson County Facilities Project Manager, with general authority to approve change orders for the Agreement for Construction Services with J. T. Vaughn Construction, LLC in relation to the Williamson County North Campus Project for any increase in costs up to a total maximum amount of \$30,000.00 in accordance with Section 262.031 of the Local Government Code – Changes in Plans and Specifications. This report is being provided for purposes of notifying the court of such change order and to place it in the minutes of the Commissioners Court.

Fiscal Impact

From/To	Acct No.	Description	Amount
---------	----------	-------------	--------

Attachments

[NCF Change Order 40](#)

[NCF CO40 Funds](#)

Form Review

Inbox

County Judge Exec Asst.

Form Started By: Gina Wrehsnig

Final Approval Date: 02/22/2018

Reviewed By

Wendy Coco

Date

02/22/2018 08:28 AM

Started On: 02/22/2018 07:52 AM



3171 SE Inner Loop
Georgetown, TX
78626

T: (512) 663-7461
F: (512) 681-9752

February 13, 2018

Dwayne Gossett
Williamson County, Texas
3101 SE Inner Loop
Georgetown, TX 78620

Re: North Campus Facilities
Job No: 233901

Subj: Change Proposal No. 233901-0040

Dear Sir or Madam:

We respectfully submit our proposal for an increase to our contract in the amount of \$0 (zero) dollars to provide Credit for Grade Beams & Pier Caps per ASI-004 for the above referenced project.

Credit for Grade Beams & Pier Caps

Our price is valid for Ten (10) days

Please indicate your acceptance of this change proposal by signing and returning one copy of the attached Form B breakdown of our cost.

Very truly yours,
VAUGHN CONSTRUCTION

Doug Boram

Attachments: Form B, Subcontractor Pricing Back-up

CC: Brody Harris - BLGY
Mark Brown - BLGY

FORM B

PROJECT: North Campus Facilities

CHANGE PROPOSAL NO: 233901-0040

QUOTATION :

Item	Labor	Materials	Subs	Total
Credit for Grade Beams & Pier Caps	\$0.00	\$0.00	\$(6,292.00)	\$(6,292.00)
To Be Credited to Owners Contingency	\$0.00	\$6,292.00	\$0.00	\$6,292.00

Totals	\$0.00	\$6,292.00	\$(6,292.00)	\$0.00
Insurance, Tax, Benefits on Labor				\$0.00
Overhead				\$0.00
Fee on Subs				\$0.00
Fee on JTV				\$0.00
Bond				\$0.00
Remodel Tax				\$0.00
TOTAL				\$0.00

TIME EXTENSION TO CONTRACT: 0 Days

Submitted Date: 2/13/2018

Accepted

VAUGHN CONSTRUCTION

By: 

By: 
Doug Boram

Date _____

Proposal Valid for 10 Days

Williamson County
 Williamson County North Campus Facilities
 Vaughn Project No. 2339-01



Funds Tracking Log

Change Proposal No.	Change Type & No.	Time Extension (Days)		GMP Breakdown						GMP #2339.01	Total Updated Contract Amount
		Pending	Approved	Cost of Work	CM Contingency	Owner Contingency	General Conditions	Buyout Savings	Construction Phase Fee		
N/A	GMP	-	-	\$18,195,395	\$406,771	\$406,772	\$1,896,522		\$625,467	\$21,530,927	\$21,530,927
1	OCO	0	0	\$3,659	\$0	(\$3,659)	\$0		\$0	\$0	\$21,530,927
2	OCO	10	10	\$114,186	\$0	(\$114,186)	\$0		\$0	\$0	\$21,530,927
3	OCO	0	0	\$1,727	\$0	(\$1,748)	\$21		\$0	\$21	\$21,530,948
4	OCO	0	0	\$19,494	\$0	(\$19,494)	\$0		\$0	\$0	\$21,530,948
5	OCO	0	0	\$19,676	(\$19,676)	\$0	\$0		\$0	\$0	\$21,530,948
6	OCO	0	0	\$14,465	(\$14,465)	\$0	\$0		\$0	\$0	\$21,530,948
7	OCO	0	0	\$2,237	\$0	(\$2,237)	\$0		\$0	\$0	\$21,530,948
8	OCO	0	0	\$3,450	\$0	(\$3,450)	\$0		\$0	\$0	\$21,530,948
9	OCO	0	0	\$832	\$0	(\$832)	\$0		\$0	\$0	\$21,530,948
10	OCO	0	0	\$285	\$0	(\$285)	\$0		\$0	\$0	\$21,530,948
11	OCO	0	0	\$22,415	\$0	(\$22,415)	\$0		\$0	\$0	\$21,530,948
12	OCO	0	0	\$11,221	\$0	(\$11,221)	\$0		\$0	\$0	\$21,530,948
13	OCO	0	0	(\$5,000)	\$0	\$5,000	\$0		\$0	\$0	\$21,530,948
14	OCO	0	0	\$0	\$0	\$0	\$0		\$0	\$0	\$21,530,948
15	OCO	0	0	\$79,584	\$0	(\$79,584)	\$0		\$0	\$0	\$21,530,948
16	OCO	0	0	\$9,930	\$0	(\$9,930)	\$0		\$0	\$0	\$21,530,948
17	OCO	0	0	\$2,450	(\$2,450)	\$0	\$0		\$0	\$0	\$21,530,948
18	OCO	0	0	\$1,747	(\$1,747)	\$0	\$0		\$0	\$0	\$21,530,948
19	OCO	0	0	(\$1,763)	\$0	\$0	\$1,763		\$0	\$0	\$21,530,948
20	OCO	0	0	\$5,784	\$0	(\$5,856)	\$72		\$0	\$72	\$21,531,020
21	OCO	0	0	\$10,364	(\$10,364)	\$0	\$0		\$0	\$0	\$21,531,020
22	OCO	0	0	\$6,410	(\$6,461)	\$0	\$51		\$0	\$0	\$21,531,020
23	OCO	0	0	\$15,825	(\$15,825)	\$0	\$0		\$0	\$0	\$21,531,020
24	OCO	0	0	\$33,487	(\$33,906)	\$0	\$419		\$0	\$0	\$21,531,020
25	OCO	0	0	\$8,854	(\$8,854)	\$0	\$0		\$0	\$0	\$21,531,020
26	OCO	0	-	(\$106)	\$0	\$106	\$0		\$0	\$0	\$21,531,020
27R	OCO	0	-	\$2,687	\$0	(\$2,687)	\$0		\$0	\$0	\$21,531,020
28	Void	0	0	\$0	\$0	\$0	\$0		\$0	\$0	\$21,531,020
29	OCO	0	-	\$3,647	(\$3,647)	\$0	\$0		\$0	\$0	\$21,531,020
30	OCO	0	0	(\$30,000)	\$0	\$30,000	\$0		\$0	\$0	\$21,531,020
31	OCO	0	0	\$4,434	\$0	(\$4,434)	\$0		\$0	\$0	\$21,531,020

32	OCO	0	0	\$6,816	\$0	(\$6,816)	\$0		\$0	\$0	\$21,531,020
33R	OCO	0	-	(\$28,265)	\$0	\$28,265	\$0		\$0	\$0	\$21,530,927
34	OCO	0	0	\$5,273	(\$5,273)	\$0	\$0		\$0	\$0	\$21,531,020
35	OCO	0	0	(\$168,250)	\$0	\$0	\$0		\$0	(\$168,250)	\$21,362,770
36	OCO	0	0	\$1,280	(\$1,280)	\$0	\$0		\$0	\$0	\$21,531,020
37	OCO	0	0	\$1,601	(\$1,601)	\$0	\$0		\$0	\$0	\$21,531,020
38R	OCO	0	-	\$4,646	(\$4,646)	\$0	\$0		\$0	\$0	\$21,531,020
39R	OCO	10	-	\$0	\$0	\$0	\$0		\$0	\$0	\$21,531,020
40R	OCO	0	-	(\$6,292)	\$0	\$6,292	\$0		\$0	\$0	\$21,531,020
Current Amounts		20	10	\$18,374,185	\$276,576	\$187,601	\$1,898,848	\$0	\$625,467	\$21,362,770	\$21,362,770



KEYSTONE
CONCRETE PLACEMENT
 35 County Rd. 150
 Georgetown, TX. 78626
 512.931.3033 / 512.931.0995 FAX

CHANGE AUTHORIZATION

To:
Doug Boran
 Vaughn Construction

Date:
 November 8, 2017

From:
 Stephen Wallace
 Keystone Concrete Placement

Project:
Williamson County N.C.F.

Change Request #06 **ASI #04**

Keystone Concrete Placement's Work:

Provide credit per ASI #04 to included grade beams and pier caps

Grade beams - 2' x 2'-7" x 54'	-3,029.94
Pier Caps (7 ea)	-3,262.00

Total Change Request: **\$ (6,292)**

Thank you,

Stephen Wallace
 Sr. Project Manager
 Keystone Concrete Placement

Williamson County Facilities - Job Cost Tracking Log

Project: North Campus Project # P324

Change Order #: 40

Change Order No.	Court Agenda Date	Party of Initiation	Time Ext. (Days)	GMP Breakdown						GMP Total	Total Updated Contract Amount
				Cost of Work	CM Contingency	Owner Contingency	Buyout Savings (Current)	General Conditions	Construction Phase Fee		
Contract				\$ 18,027,145.00	\$ 406,771.00	\$ 406,772.00	\$ -	\$ 1,896,522.00	\$ 625,467.00	\$ 21,362,677.00	\$ 21,362,677.00
1	03/28/17		0	\$ 3,659.00	\$ -	\$ (3,659.00)	\$ -	\$ -	\$ -	\$ -	\$ 21,362,677.00
2	03/28/17		10	\$ 114,186.00	\$ -	\$ (114,186.00)	\$ -	\$ -	\$ -	\$ -	\$ 21,362,677.00
3	05/02/17		0	\$ 1,727.00	\$ -	\$ (1,727.00)	\$ -	\$ -	\$ -	\$ -	\$ 21,362,677.00
4	05/02/17		0	\$ 19,494.00	\$ -	\$ (19,494.00)	\$ -	\$ -	\$ -	\$ -	\$ 21,362,677.00
5	05/30/17		0	\$ 19,676.00	\$ (19,676.00)	\$ -	\$ -	\$ -	\$ -	\$ -	\$ 21,362,677.00
6	05/30/17		0	\$ 14,465.00	\$ (14,465.00)	\$ -	\$ -	\$ -	\$ -	\$ -	\$ 21,362,677.00
7	05/30/17		0	\$ 2,237.00	\$ -	\$ (2,237.00)	\$ -	\$ -	\$ -	\$ -	\$ 21,362,677.00
8	05/30/17		0	\$ 3,450.00	\$ -	\$ (3,450.00)	\$ -	\$ -	\$ -	\$ -	\$ 21,362,677.00
9	06/27/17		0	\$ 832.00	\$ -	\$ (832.00)	\$ -	\$ -	\$ -	\$ -	\$ 21,362,677.00
10	06/27/17		0	\$ 285.00	\$ -	\$ (285.00)	\$ -	\$ -	\$ -	\$ -	\$ 21,362,677.00
11	06/27/17		0	\$ 22,415.00	\$ -	\$ (22,415.00)	\$ -	\$ -	\$ -	\$ -	\$ 21,362,677.00
12	06/27/17		0	\$ 11,221.00	\$ -	\$ (11,221.00)	\$ -	\$ -	\$ -	\$ -	\$ 21,362,677.00
13	06/27/17		0	\$ (5,000.00)	\$ -	\$ 5,000.00	\$ -	\$ -	\$ -	\$ -	\$ 21,362,677.00
14	06/27/17		0	\$ -	\$ -	\$ -	\$ -	\$ -	\$ -	\$ -	\$ 21,362,677.00
15	06/27/17		0	\$ 79,584.00	\$ -	\$ (79,584.00)	\$ -	\$ -	\$ -	\$ -	\$ 21,362,677.00
16	06/27/17		0	\$ 9,930.00	\$ -	\$ (9,930.00)	\$ -	\$ -	\$ -	\$ -	\$ 21,362,677.00
17	09/12/17	A&E	0	\$ 2,450.00	\$ -	\$ -	\$ (2,450.00)	\$ -	\$ -	\$ -	\$ 21,362,677.00
18	09/12/17	A&E	0	\$ 1,747.00	\$ (1,747.00)	\$ -	\$ -	\$ -	\$ -	\$ -	\$ 21,362,677.00
19	09/12/17	Owner	0	\$ 577,128.00	\$ -	\$ -	\$ (577,128.00)	\$ -	\$ -	\$ -	\$ 21,362,677.00
20	12/05/17	A&E	0	\$ 5,784.00	\$ -	\$ (5,856.00)	\$ -	\$ 72.00	\$ -	\$ -	\$ 21,362,677.00
21	10/03/17	A&E	0	\$ 10,364.00	\$ (10,364.00)	\$ -	\$ -	\$ -	\$ -	\$ -	\$ 21,362,677.00
22	10/03/17	A&E	0	\$ 6,461.00	\$ (6,461.00)	\$ -	\$ -	\$ -	\$ -	\$ -	\$ 21,362,677.00
23	12/05/17	A&E	0	\$ 15,825.00	\$ (15,825.00)	\$ -	\$ -	\$ -	\$ -	\$ -	\$ 21,362,677.00
24	10/03/17	A&E	0	\$ 33,906.00	\$ (33,906.00)	\$ -	\$ -	\$ -	\$ -	\$ -	\$ 21,362,677.00
25	10/03/17	A&E	0	\$ 8,854.00	\$ (8,854.00)	\$ -	\$ -	\$ -	\$ -	\$ -	\$ 21,362,677.00
26	02/06/18	A&E	0	\$ (106.00)	\$ -	\$ 106.00	\$ -	\$ -	\$ -	\$ -	\$ 21,362,677.00
27		A&E	0	\$ 2,687.00	\$ -	\$ (2,687.00)	\$ -	\$ -	\$ -	\$ -	\$ 21,362,677.00
28	PENDING REVIEW										\$ 21,362,677.00
29	02/06/18	A&E	0	\$ 3,647.00	\$ (3,647.00)	\$ -	\$ -	\$ -	\$ -	\$ -	\$ 21,362,677.00
30	10/24/17	Contractor		\$ (30,000.00)	\$ -	\$ 30,000.00	\$ -	\$ -	\$ -	\$ -	\$ 21,362,677.00
31	10/24/17	A&E		\$ 4,434.00	\$ -	\$ (4,434.00)	\$ -	\$ -	\$ -	\$ -	\$ 21,362,677.00
32	11/14/17	A&E		\$ 6,816.00		\$ (6,816.00)	\$ -	\$ -	\$ -	\$ -	\$ 21,362,677.00
33	PENDING REVIEW										\$ 21,362,677.00
34	11/14/17	Contractor		\$ 5,273.00	\$ (5,273.00)	\$ -	\$ -	\$ -	\$ -	\$ -	\$ 21,362,677.00
35	PENDING REVIEW										\$ 21,362,677.00
36	12/05/17	A&E	0	\$ 1,280.00	\$ (1,280.00)	\$ -	\$ -	\$ -	\$ -	\$ -	\$ 21,362,677.00
37	12/05/17	A&E	0	\$ 1,601.00	\$ (1,601.00)	\$ -	\$ -	\$ -	\$ -	\$ -	\$ 21,362,677.00
38	PENDING REVIEW										\$ 21,362,677.00
39		Contractor	15	\$ -	\$ -	\$ -	\$ -	\$ -	\$ -	\$ -	\$ 21,362,677.00
40		Contractor	0	\$ (6,292.00)	\$ -	\$ 6,292.00	\$ -	\$ -	\$ -	\$ -	\$ 21,362,677.00
41	02/06/18	Owner	0	\$ (50,311.00)		\$ 50,311.00	\$ -	\$ -	\$ -	\$ -	\$ 21,362,677.00
							\$ -	\$ -	\$ -	\$ -	\$ 21,362,677.00
			25	\$ 18,926,854.00	\$ 283,672.00	\$ 209,668.00	\$ (579,578.00)	\$ 1,896,594.00	\$ 625,467.00	\$ 21,362,677.00	\$ 21,362,677.00

Commissioners Court - Regular Session

16.

Meeting Date: 02/27/2018

North Campus Facility P324 - Change Order 43

Submitted By: Gina Wrehsnig, Infrastructure

Department: Infrastructure

Division: Building Maintenance

Agenda Category: Consent

Information

Agenda Item

Discuss, consider and take appropriate action on accepting and approving a report on the Williamson County North Campus Project; Change Order #43 in the amount of \$24,129.00 for the addition of an HVAC unit at Stairwell # 2, which was executed by Dwayne Gossett, Williamson County Facilities Project Manager, pursuant to the previous grant of authority under Section 262.031 of the Local Government Code. This change order is to be funded by the Owners Contingency.

Background

On September 6, 2016, the Williamson County Commissioners Court granted Dwayne Gossett, Williamson County Facilities Project Manager, with general authority to approve change orders for the Agreement for Construction Services with J. T. Vaughn Construction, LLC in relation to the Williamson County North Campus Project for any increase in costs up to a total maximum amount of \$30,000.00 in accordance with Section 262.031 of the Local Government Code – Changes in Plans and Specifications. This report is being provided for purposes of notifying the court of such change order and to place it in the minutes of the Commissioners Court.

Fiscal Impact

From/To	Acct No.	Description	Amount
---------	----------	-------------	--------

Attachments

[NCF Change Order 43](#)

[NCF CO43 Funds](#)

Form Review

Inbox

County Judge Exec Asst.

Form Started By: Gina Wrehsnig

Final Approval Date: 02/22/2018

Reviewed By

Wendy Coco

Date

02/22/2018 08:28 AM

Started On: 02/22/2018 07:58 AM



3171 SE Inner Loop
Georgetown, TX
78626

T: (512) 663-7461
F: (512) 681-9752

February 13, 2018

Dwayne Gossett
Williamson County, Texas
3101 SE Inner Loop
Georgetown, TX 78620

Re: North Campus Facilities
Job No: 233901

Subj: Change Proposal No. 233901-0043

Dear Sir or Madam:

We respectfully submit our proposal for an increase to our contract in the amount of \$0 (zero) dollars to provide Addition of Cooling to Stair No. 2 per ASI-035 for the above referenced project.

Please indicate your acceptance of this change proposal by signing and returning one copy of the attached Form B breakdown of our cost.

Very truly yours,
VAUGHN CONSTRUCTION

A handwritten signature in blue ink, appearing to read "Doug Boram".

Doug Boram

Attachments: Form B, Subcontractor Pricing Back-up

CC: Brody Harris - BLGY
Mark Brown - BLGY

FORM B

PROJECT: North Campus Facilities

CHANGE PROPOSAL NO: 233901-0043

QUOTATION :

Item	Labor	Materials	Subs	Total
Provide and install flashing boots at three (3) electrical penetrations and pads under supports.	\$0.00	\$0.00	\$1,350.00	\$1,350.00
Install power to mini-split at Stair No. 2	\$0.00	\$0.00	\$5,898.00	\$5,898.00
Provide and install mini-split, piping, controls and insulation at Stair No. 2	\$0.00	\$0.00	\$14,290.00	\$14,290.00
Unknown waterproofing repairs	\$0.00	\$0.00	\$2,500.00	\$2,500.00
To Be Funded by Owners Contingency	\$0.00	\$(24,129.00)	\$0.00	\$(24,129.00)
Vaughn Subcontract Default Insurance	\$0.00	\$0.00	\$91.00	\$91.00

Totals	\$0.00	\$(24,129.00)	\$24,129.00	\$0.00
				Insurance, Tax, Benefits on Labor
				\$0.00
				Overhead
				\$0.00
				Fee on Subs
				\$0.00
				Fee on JTV
				\$0.00
				Bond
				\$0.00
				Remodel Tax
				\$0.00
TOTAL				\$0.00

TIME EXTENSION TO CONTRACT: 0 Days

Submitted Date: 2/13/2018

Accepted

By: 

Date _____

VAUGHN CONSTRUCTION

By: 
Doug Boram

Proposal Valid for Days

Williamson County
 Williamson County North Campus Facilities
 Vaughn Project No. 2339-01



Funds Tracking Log

Change Proposal No.	Change Type & No.	Time Extension (Days)		GMP Breakdown						GMP #2339.01	Total Updated Contract Amount
		Pending	Approved	Cost of Work	CM Contingency	Owner Contingency	General Conditions	Buyout Savings	Construction Phase Fee		
N/A	GMP	-	-	\$18,195,395	\$406,771	\$406,772	\$1,896,522		\$625,467	\$21,530,927	\$21,530,927
1	OCO	0	0	\$3,659	\$0	(\$3,659)	\$0		\$0	\$0	\$21,530,927
2	OCO	10	10	\$114,186	\$0	(\$114,186)	\$0		\$0	\$0	\$21,530,927
3	OCO	0	0	\$1,727	\$0	(\$1,748)	\$21		\$0	\$21	\$21,530,948
4	OCO	0	0	\$19,494	\$0	(\$19,494)	\$0		\$0	\$0	\$21,530,948
5	OCO	0	0	\$19,676	(\$19,676)	\$0	\$0		\$0	\$0	\$21,530,948
6	OCO	0	0	\$14,465	(\$14,465)	\$0	\$0		\$0	\$0	\$21,530,948
7	OCO	0	0	\$2,237	\$0	(\$2,237)	\$0		\$0	\$0	\$21,530,948
8	OCO	0	0	\$3,450	\$0	(\$3,450)	\$0		\$0	\$0	\$21,530,948
9	OCO	0	0	\$832	\$0	(\$832)	\$0		\$0	\$0	\$21,530,948
10	OCO	0	0	\$285	\$0	(\$285)	\$0		\$0	\$0	\$21,530,948
11	OCO	0	0	\$22,415	\$0	(\$22,415)	\$0		\$0	\$0	\$21,530,948
12	OCO	0	0	\$11,221	\$0	(\$11,221)	\$0		\$0	\$0	\$21,530,948
13	OCO	0	0	(\$5,000)	\$0	\$5,000	\$0		\$0	\$0	\$21,530,948
14	OCO	0	0	\$0	\$0	\$0	\$0		\$0	\$0	\$21,530,948
15	OCO	0	0	\$79,584	\$0	(\$79,584)	\$0		\$0	\$0	\$21,530,948
16	OCO	0	0	\$9,930	\$0	(\$9,930)	\$0		\$0	\$0	\$21,530,948
17	OCO	0	0	\$2,450	(\$2,450)	\$0	\$0		\$0	\$0	\$21,530,948
18	OCO	0	0	\$1,747	(\$1,747)	\$0	\$0		\$0	\$0	\$21,530,948
19	OCO	0	0	(\$1,763)	\$0	\$0	\$1,763		\$0	\$0	\$21,530,948
20	OCO	0	0	\$5,784	\$0	(\$5,856)	\$72		\$0	\$72	\$21,531,020
21	OCO	0	0	\$10,364	(\$10,364)	\$0	\$0		\$0	\$0	\$21,531,020
22	OCO	0	0	\$6,410	(\$6,461)	\$0	\$51		\$0	\$0	\$21,531,020
23	OCO	0	0	\$15,825	(\$15,825)	\$0	\$0		\$0	\$0	\$21,531,020
24	OCO	0	0	\$33,487	(\$33,906)	\$0	\$419		\$0	\$0	\$21,531,020
25	OCO	0	0	\$8,854	(\$8,854)	\$0	\$0		\$0	\$0	\$21,531,020
26	OCO	0	-	(\$106)	\$0	\$106	\$0		\$0	\$0	\$21,531,020
27R	OCO	0	-	\$2,687	\$0	(\$2,687)	\$0		\$0	\$0	\$21,531,020
28	Void	0	0	\$0	\$0	\$0	\$0		\$0	\$0	\$21,531,020
29	OCO	0	-	\$3,647	(\$3,647)	\$0	\$0		\$0	\$0	\$21,531,020
30	OCO	0	0	(\$30,000)	\$0	\$30,000	\$0		\$0	\$0	\$21,531,020
31	OCO	0	0	\$4,434	\$0	(\$4,434)	\$0		\$0	\$0	\$21,531,020

32	OCO	0	0	\$6,816	\$0	(\$6,816)	\$0		\$0	\$0	\$21,531,020
33R	OCO	0	-	(\$28,265)	\$0	\$28,265	\$0		\$0	\$0	\$21,530,927
34	OCO	0	0	\$5,273	(\$5,273)	\$0	\$0		\$0	\$0	\$21,531,020
35	OCO	0	0	(\$168,250)	\$0	\$0	\$0		\$0	(\$168,250)	\$21,362,770
36	OCO	0	0	\$1,280	(\$1,280)	\$0	\$0		\$0	\$0	\$21,531,020
37	OCO	0	0	\$1,601	(\$1,601)	\$0	\$0		\$0	\$0	\$21,531,020
38R	OCO	0	-	\$4,646	(\$4,646)	\$0	\$0		\$0	\$0	\$21,531,020
39R	OCO	10	-	\$0	\$0	\$0	\$0		\$0	\$0	\$21,531,020
40R	OCO	0	-	(\$6,292)	\$0	\$6,292	\$0		\$0	\$0	\$21,531,020
41	OCO	0	-	(\$50,311)	\$0	\$50,311	\$0		\$0	\$0	\$21,531,020
42R	OCO	0	-	(\$44,494)	\$0	\$44,494	\$0		\$0	\$0	\$21,531,020
43R	OCO	0	-	\$24,129	\$0	(\$24,129)	\$0		\$0	\$0	\$21,531,020
Current Amounts		20	10	\$18,303,509	\$276,576	\$258,277	\$1,898,848	\$0	\$625,467	\$21,362,770	\$21,362,770



January 2, 2018

Thomas Morrill
Vaughn Construction
TMorrill@vaughnconstruction.com

P.O. Box 1299
11303 Conroy Lane
Manhaca, Texas 78652
(512) 280-1030
Fax # (512) 280-1032

RE: Wilco North Campus Facility
ASI #35

P.O. Box 271482
Corpus Christi, TX 78427
1955 Saratoga
Corpus Christi, TX 78417
(361) 289-2944
Fax # (361) 289-7163

We propose to furnish the necessary equipment, material, labor, safety, and insurance to provide the following scope of work:

Scope of Work:

Provide and install flashing boots at three (3) electrical penetrations and pads under supports.

Material	\$250.00
Labor	<u>1,100.00</u>
Total	\$1,350.00

Respectfully,

Jennifer McCauley



**INSIST ON
A PROFESSIONAL
ROOFING CONTRACTOR.**



**NATIONAL
ROOFING
CONTRACTORS
ASSOCIATION
MEMBER**



LOCHRIDGE PRIEST
HEATING • AIR CONDITIONING • PLUMBING

TACLA28343C

M-41036

Price Change Order #

016

Date: **January 4, 2018**

To: **Vaughn Construction**
3920 N. IH-35
Austin, Texas 78751

Job Name: **Williamson County North
Campus Facility**

Attn: **Doug Boram**

Job Location: 3171 SE Inner Loop
Georgetown, Texas 78626

LP Job #: **HC16-651**

Reference: **Additional Mini Split**

Please (add) the amount below per the items listed in the breakout sheet. This change proposal is for installing a new mini split in Building H Stairwell.

Base Bid Total: **\$14,290.00**

Inclusions: Additional Mini-Split, Piping, Controls and Insulation (Material and Labor)

Exclusions: Bond, overtime and original contract exclusions.

By: 

Mark Veselka
Project Manager

Please Note: Lochridge Priest has the right to reprice this change order in the event that the supplied information is incorrect or differs from the actual field situation.

Lochridge Priest

JOB NAME:		HVAC & PLUMBING SHORT RECAP				PRINT TIME: 1/4/2018 7:39		
LOCATION:		Williamson County NCF Additional Mini Split				BID DATE: 9/26/2017		
LABOR RATE: \$ 40.00		MAN HRS		EQUIP	MAT'L	LABOR	SUB-MISC	
MCA %: 100%		UNIT HRS	EXT HRS	\$	\$	\$		
P L U M B I N G	QUAN	DESCRIPTION						
	1	Condensate Piping	13	13	\$ -	\$ 472	\$ 500	\$ -
	1		0	0	\$ -	\$ -	\$ -	\$ -
	1		0	0	\$ -	\$ -	\$ -	\$ -
	1		0	0	\$ -	\$ -	\$ -	\$ -
	1		0	0	\$ -	\$ -	\$ -	\$ -
	1		0	0	\$ -	\$ -	\$ -	\$ -
	1		0	0	\$ -	\$ -	\$ -	\$ -
	1	20% ADD FOR MED. GAS. PIP	0	0	\$ -	\$ -	\$ -	\$ -
	1	10% ADD FOR DOM. WTR. PI	0	0	\$ -	\$ -	\$ -	\$ -
		- TAG & ID	-	0	\$ -	\$ -	\$ -	\$ -
		- TESTING 10.0%	-	1	\$ -	\$ -	\$ 50	\$ -
		- SUPERVISION 10.0%	-	1	\$ -	\$ -	\$ 55	\$ -
PLUMBING TOTALS			15	\$ -	\$ 472	\$ 605	\$ -	
P I P I N G	QUAN	DESCRIPTION						
	1	Refrigerant Copper	18	18	\$ -	\$ 492	\$ 720	\$ -
	1	Split System	24	24	\$ 3,895	\$ 300	\$ 960	\$ -
	1		0	0	\$ -	\$ -	\$ -	\$ -
	1		0	0	\$ -	\$ -	\$ -	\$ -
	1		0	0	\$ -	\$ -	\$ -	\$ -
	1		0	0	\$ -	\$ -	\$ -	\$ -
	1		0	0	\$ -	\$ -	\$ -	\$ -
	1	10% ADD FOR 1" & DOWN PIP	0	0	\$ -	\$ -	\$ -	\$ -
		- TAG & ID	-	0	\$ -	\$ -	\$ -	\$ -
	- SUPERVISION 10.0%	-	4	\$ -	\$ -	\$ 168	\$ -	
PIPING TOTALS			46	\$ 3,895	\$ 792	\$ 1,848	\$ 0	
S H E E T M E T A L	#'S OF DUCT:							
	LABOR RATES							
	\$ 40.00	SHOP	-	0	\$ -	\$ -	\$ -	
	\$ 40.00	HANDLING	-	0	\$ -	\$ -	\$ -	
	\$ 40.00	FIELD	-	0	\$ -	\$ -	\$ -	
	QUAN	DESCRIPTION						
	1	Sheetmetal Shop Expense			\$ -	\$ -	\$ -	\$ -
	1	20% FIELD CORR. FACTOR	0	0	\$ -	\$ -	\$ -	\$ -
	1	Wire	0	0	\$ -	\$ 20	\$ -	\$ -
	1		0	0	\$ -	\$ -	\$ -	\$ -
1		0	0	\$ -	\$ -	\$ -	\$ -	
1		0	0	\$ -	\$ -	\$ -	\$ -	
1		0	0	\$ -	\$ -	\$ -	\$ -	
1		0	0	\$ -	\$ -	\$ -	\$ -	
1		0	0	\$ -	\$ -	\$ -	\$ -	
1		0	0	\$ -	\$ -	\$ -	\$ -	
	- SUPERVISION 10.0%	-	0	\$ -	\$ -	\$ -	\$ -	
SHEETMETAL TOTALS			0	\$ -	\$ 20	\$ -	\$ -	
HVAC TOTALS			46	\$ 3,895	\$ 812	\$ 1,848	\$ -	
S U B & M I S C	LINE	DESCRIPTION	VENDOR				SUBCONTRACTOR	
	1	INSULATION	Chaparrai		\$ -	\$ -	\$ 500	
	2	TEMP CONTROLS	Atuo Logic		\$ -	\$ -	\$ 2,200	
	3	Test and Balance	PHI		\$ -	\$ -	No Price	
	4				\$ -	\$ -	\$ -	
	5				\$ -	\$ -	\$ -	
	6				\$ -	\$ -	\$ -	
	7	CLEAN UP CREW	2.0%		\$ -	\$ -	\$ 49	
	8	EQUIPMENT RENTAL			\$ -	\$ -	\$ -	
	9	SU; T & B ; G & A			\$ -	\$ -	\$ 720	
	- SMALL TOOL/MISC MTL/WARRANTY			\$ -	\$ 218	\$ 156		
SUB & MISC. TOTALS					\$ 218	\$ 769	\$ 3,191	
M I S C	STARTUP LABOR RATE:	\$ 90.00	SUMMARY					
	EQUIPMENT ADJUSTMENT:	\$ -		HVAC	SUB & MISC.	PLUMBING	TOTALS	
	WARRANTY %:	4%	EQUIP	\$ 3,895	\$ -	\$ -	\$ 3,895	
	MISC. MATERIAL %:	17%	MATL	\$ 812	\$ 218	\$ 472	\$ 1,502	
			LABOR	\$ 1,848	\$ 769	\$ 605	\$ 3,222	
	DESCRIPTION:		S/M	\$ -	\$ 3,191	\$ -	\$ 3,191	
		0.00%	TAX	\$ -	\$ -	\$ -	\$ -	
		10%	COST	\$ 6,555	\$ 4,178	\$ 1,077	\$ 11,810	
			GEN. COND.	\$ 656	\$ 418	\$ 108	\$ 1,181	
		10%	SUBTOTAL	\$ 7,211	\$ 4,596	\$ 1,184	\$ 12,991	
		FEE	\$ 721	\$ 460	\$ 118	\$ 1,299		
		BID W/O BOND	\$ 7,932	\$ 5,056	\$ 1,303	\$ 14,290		
		PERF. BOND				\$ -		
		JOB TOTAL BID				\$ 14,290		
		% M/U v LABOR	39.0%	59.8%	19.6%	40.3%		

Lochridge Priest

GENERAL ADMINISTRATIVE & MISCELLANEOUS SUMMARY							
JOB NAME:		Williamson County NCF		PRINT TIME:		1/4/2018 7:39	
LOCATION:		Additional Mini Split		BID DATE:		9/26/2017	
				EST. NO.:		LPPCO-016	
GEN & ADMIN	DESCRIPTION	UNIT COST	UNIT MEASURE	QUANTITY	TOTAL COST		
1	PROJECT MANAGER	\$ 75	Hr	4.00	\$ 300		
2	ASSISTANT PROJECT MANAGER	\$ 10,700	Month	0.00	\$ -		
3	SUPERINTENDENT	\$ 15,500	Month	0.00	\$ -		
4	SECRETARIES	\$ 35	Hr	1.00	\$ 35		
5	PROJECT OFFICE	\$ 2,062	Month	0.00	\$ -		
6	ENGINEERING	\$ 99	Hour	0.00	\$ -		
7	TELEPHONE/FAX/OFFICE SUPPLIES	\$ 1,000	Month	0.00	\$ -		
8	SHEET METAL CARTAGE	\$ 700	Trip	0.00	\$ -		
9	PICK-UP & DELIVERIES	\$ 375	Each	0.00	\$ -		
10	NEW HIRE COSTS/SAFETY TRAINING	\$ 500	Each	0.00	\$ -		
11	ESTIMATING	\$ 80	Hour	0.00	\$ -		
12	SHOP & RECORD DRAWINGS - 8% OF LABOR	\$ 45	Hour	0.00	\$ -		
GENERAL ADMINISTRATIVE SUMMARY TOTAL					\$ 335		

EQUIPMENT RENTAL				
DESCRIPTION	UNIT COST	UNIT MEASURE	QUAN.	TOTAL COST
185 CFM AIR COMP W/HOSES	\$ 2,174.00	MONTH	0	\$ -
SCISSOR LIFT -- 15 FT ELEC	\$ 300.00	Week	0	\$ -
GENERATOR - 4000 WATT	\$ 457.00	MONTH	0	\$ -
FORK LIFT -- WAREHOUSE 5000LB	\$ 1,716.00	MONTH	0	\$ -
SKYTRACK	\$ 3,457.00	MONTH	0	\$ -
WELDING MACHINE - GASOLINE	\$ 692.00	MONTH	0	\$ -
Mini-Ex	\$ 466.00	Week	0	\$ -
TRACKHOE -- 13-15 FT	\$ 5,102.00	MONTH	0	\$ -
COMPACTOR	\$ 500.00	MONTH	0	\$ -
TRENCHER	\$ 9,500.00	Week	0	\$ -
TRENCHER DELIVERY/PICKUP	\$ 750.00	LOT	0	\$ -
FUEL	\$ 1,073.00	LOT	0	\$ -
RENTAL EQUIPMENT INSURANCE	\$ -		0	\$ -
RENTAL EQUIPMENT TAX				\$ -
TOTAL EQUIP RENTAL				\$ -

BALANCE -- STARTUP									
AIR & WATER									
QUAN	DESCRIPTION	PIPING		SHEETMETAL		PIPING		SHEETMETAL	
		STRTUP UNIT	BAL UNIT	STRTUP UNIT	BAL UNIT	STRTUP EXT	BAL EXT	STRTUP EXT	BAL EXT
1	CT&S	8.00	0.00	0.00	0.00	8	0	0	0
0	-	0.00	0.00	0.00	0.00	0	0	0	0
0	-	0.00	0.00	0.00	0.00	0	0	0	0
0	-	0.00	0.00	0.00	0.00	0	0	0	0
0	-	0.00	0.00	0.00	0.00	0	0	0	0
0	-	0.00	0.00	0.00	0.00	0	0	0	0
0	-	0.00	0.00	0.00	0.00	0	0	0	0
0	-	0.00	0.00	0.00	0.00	0	0	0	0
0	G/R/D	0.00	0.00	0.00	0.50	0	0	0	0
SUB-TOTALS						8	0	0	0
						PIPING		SHT MTL	
START UP TOTALS						8 MANHRS		0 MANHRS	
BALANCE TOTALS						0 MANHRS		0 MANHRS	
MNHR						COST			
STARTUP - PIPING		8		\$		720.00			
STARTUP - SHEETMETAL		0		\$		-			
BALANCE - PIPING		0		\$		-			
BALANCE - SHEETMETAL		0		\$		-			
TOTAL		8		\$		720.00			



Date: January 2, 2018
Company: Lochridge Priest
Attn: Mark Veselka
Re: Williamson County NCF ASI-035

PROPOSAL

Chaparral insulation is pleased to submit this proposal for the above referenced project. This includes all necessary labor, materials and equipment to complete this scope of work. The system inclusions are as follows and the application procedures are held in strict accordance with the specifications and construction documents

HVAC: Insulate condensate for addition of ductless split to serve stair #2 per ASI-035.

Plumbing: None

Specification section(s): Original Specifications
Addendums Acknowledged: 0
Per plans dated: 12.21.17

EXCLUSIONS: Original project exclusions apply

Pricing Breakdown:	HVAC	Plumbing
Pricing:	\$ 500.00	

TAX: This price does not include sales tax. We will require a sales tax certificate for our files or sales tax will be added.
CLEARANCE: Pipe/Duct routing and penetrations must provide enough space and/or clearance to allow for full sizing of insulation specified.
CLEAN-UP: Chaparral will clean up their own area on a daily basis to remove any insulation scraps, debris or garbage. However, we will not provide clean-up crews directed by another company.

SCHEDULING: This proposal is based on sequencing work properly to provide sufficient time to complete our scope of work. The insulation scope of the project needs to be included when the project schedule is being created.
INSURANCE: Chaparral insulation is fully insured general liability and workers compensation coverage in excess of most contract requirements.
30-DAY PRICE: This proposal is in affect for a period of thirty (30) days. We reserve the right to withdraw this proposal and any related future pricing if both parties cannot agree on the conditions.

Thanks,

Pat Moore
 Project Manager
 Chaparral Insulation Co, Inc.



Mark Veselka

From: Yerges, Dan UTC CCS <Dan.Yerges@automatedlogic.com>
Sent: Wednesday, December 27, 2017 3:36 PM
To: Mark Veselka
Subject: Re: [External] FW: Wilco NCF Add Mini-Split System

Mark,

I'm not in the office this week, but if you need a price, use \$2200.00. This only includes monitoring the space temperature. It does not include any wiring of the mini-split.

Sent from my iPhone

On Dec 27, 2017, at 1:22 PM, Mark Veselka <mark@lochridgepriest.com> wrote:

Gentlemen,

Please send me a price for the proposed change as soon as possible.

Thanks,
Mark Veselka
Project Manager
Lochridge-Priest, Inc.
Cell: (254) 379-3059
Direct Phone: (254) 492-8158
Direct Fax: (254) 492-8258
<image001.png>

From: Stuart Baker [<mailto:sbaker@vaughnconstruction.com>]
Sent: Thursday, December 21, 2017 11:18 AM
To: Doug Boram <dougboram@vaughnconstruction.com>; Camille Carpenter <CCarpenter@vaughnconstruction.com>; Mark Veselka <mark@lochridgepriest.com>; John Bayer <jbayer@lochridgepriest.com>; Scott Schwartz <sschwartz@schmidt-electric.com>; itomastik@schmidt-electric.com
Subject: Fwd: Wilco NCF Add Mini-Split System

Please take a look at this and give me some input on routing.

Sent from my iPhone

Begin forwarded message:

From: Byron Hendrix <byronh@hceengineer.com>
Date: December 21, 2017 at 11:07:56 CST
To: "SBAKER@VAUGHNCONSTRUCTION.COM" <SBAKER@VAUGHNCONSTRUCTION.COM>
Cc: Brody Harris <BHarris@blgy.com>
Subject: FW: Wilco NCF Add Mini-Split System

STEVE,

I'm calling shortly.

Telephone is my primary form of communication, email is for information transfer only.
If it is important or needs immediate attention please call.

Thanks,

Byron J. Hendrix, P.E., C.E.A., LEED AP

Hendrix Consulting Engineers

MEP- Field Investigation - Commissioning
Energy Consulting - Energy Auditing
115 East Main ST., Round Rock, Texas 78664
(512) 218-0060 TEL ext 313
(512) 218-0077 FAX
(512) 468-6265 CELL
www.hcengineer.com

From: Ricky Davidson

Sent: Thursday, December 21, 2017 10:31 AM

To: Buck Hendrix <buckh@hcengineer.com>; Byron Hendrix
<byronh@hcengineer.com>

Subject: Wilco NCF Add Mini-Split System

Buck,

Plans to add mini-split

Respectfully,

Ricky Davidson, Mechanical Designer

www.hcengineer.com | RickyD@HCEngineer.com

Hendrix Consulting Engineers

115 East Main Street 512.218.0060 (P)
Round Rock, TX 78664 512.218.0077 (F)

<03M1.02 MINI-SPLIT SCHEDULE.pdf>

<03Ph2.02 2ND FLOOR PLAN.pdf>

<03Ph3.01 ROOF PLAN.pdf>

CONDENSATE / PIPING

Project		Waco VA CoGen						
Date		8/26/13			PRICES UPDATED			Jul-08
Item	Item names	Qty	Unit	Labor Unit	Labor Hours	Material Unit	Material Amount	
1	COPPER PIPE TYPE M							
2	3/4"	0	FT	0.04	0	\$2.00	\$0.00	
3	1"	60	FT	0.05	3	\$3.15	\$189.00	
4	1 1/4"	0	FT	0.05	0	\$4.65	\$0.00	
5	1 1/2"	0	FT	0.06	0	\$6.50	\$0.00	
6	2"	0	EA	0.07	0	\$10.15	\$0.00	
7								
8	COPPER MALE ADAPTERS							
9	3/4"	0	EA	0.21	0	\$2.53	\$0.00	
10	1"	1	EA	0.25	0.25	\$6.04	\$6.04	
11	1 1/4"	0	EA	0.27	0	\$8.82	\$0.00	
12	1 1/2"	0	EA	0.3	0	\$11.02	\$0.00	
13	2"	0	EA	0.7	0	\$18.87	\$0.00	
14								
15	COPPER FEMALE ADAPTERS							
16	3/4"	0	EA	0.21	0	\$3.26	\$0.00	
17	1"	0	EA	0.25	0	\$7.05	\$0.00	
18	1 1/4"	0	EA	0.27	0	\$11.02	\$0.00	
19	1 1/2"	0	EA	0.3	0	\$17.18	\$0.00	
20	2"	0	EA	0.7	0	\$23.29	\$0.00	
21								
22	COPPER UNIONS							
23	3/4"	0	EA	0.42	0	\$9.90	\$0.00	
24	1"	4	EA	0.5	2	\$16.48	\$65.92	
25	1 1/4"	0	EA	0.54	0	\$26.96	\$0.00	
26	1 1/2"	0	EA	0.6	0	\$35.72	\$0.00	
27	2"	0	EA	0.7	0	\$49.76	\$0.00	
28								
29	COPPER TEES							
30	3/4"	0	EA	0.63	0	\$3.15	\$0.00	
31	1"	2	EA	0.75	1.5	\$9.07	\$18.14	
32	1 1/4"	0	EA	0.81	0	\$12.35	\$0.00	
33	1 1/2"	0	EA	0.9	0	\$19.12	\$0.00	
34	2"	0	EA	1.05	0	\$29.86	\$0.00	
35								
36	COPPER ELLS							
37	3/4"	0	EA	0.42	0	\$1.76	\$0.00	
38	1"	6	EA	0.5	3	\$3.89	\$23.34	
39	1 1/4"	0	EA	0.54	0	\$5.91	\$0.00	
40	1 1/2"	0	EA	0.6	0	\$9.13	\$0.00	
41	2"	0	EA	0.7	0	\$16.87	\$0.00	
42								
43	COPPER COUPLINGS							
44	3/4"	0	EA	0.2	0	\$1.16	\$0.00	
45	1"	1	EA	0.25	0.25	\$2.17	\$2.17	
46	1 1/4"	0	EA	0.27	0	\$3.85	\$0.00	

47	1 1/2"			0	EA	0.3	0	\$5.03	\$0.00
48	2"			0	EA	0.4	0	\$8.53	\$0.00
49									
50	THREADED PLUGS 3/4" - 1 1/4"			0	EA	0.2	0	\$4.50	\$0.00
51	WELDING MATERIALS			14	FTS	0	0	\$0.50	\$7.00
52									
53	60	FT	HANGERS	10	EA	0.25	2.5	\$16.00	\$160.00
CONDENSATE / PIPING LABOR							12.5	M-TOTAL	\$471.61

TRAVEL							
				MAN HOURS PER TRAVEL	MILES PER TRAVEL	TRAVEL	
TOTAL HOURS DEVIDED BY 24 = TRIPS				TRIPS	ROUND TRIP	ME/HOU	TRIP
				1	0	0	0
							\$0.45
							\$0.00

REFIGERATION / PIPING

Project		Waco VA CoGen						
Date		8/26/13			PRICES UPDATED			Jan-13
Item	Item names	Qty	Unit	Labor Unit	Labor Hours	Material Unit	Material Amount	
COPPER PIPE HARD DRAWN								
	3/8"	60	FT	0.05	3	\$0.75	\$45.00	
	1/2"	0	FT	0.05	0	\$1.51	\$0.00	
	5/8"	60	FT	0.05	3	\$1.40	\$84.00	
	3/4"	0	FT	0.06	0	\$2.62	\$0.00	
	7/8"	0	FT	0.06	0	\$3.05	\$0.00	
	1 1/8"	0	FT	0.07	0	\$4.45	\$0.00	
	1 3/8"	0	FT	0.08	0	\$5.52	\$0.00	
	1 5/8"	0	FT	0.09	0	\$8.01	\$0.00	
	2 1/8"	0	FT	0.1	0	\$12.85	\$0.00	
COPPER COUPLINGS								
	3/8"	4	EA	0.26	1.04	\$0.75	\$3.00	
	1/2"	0	EA	0.29	0	\$0.53	\$0.00	
	5/8"	4	EA	0.33	1.32	\$1.00	\$4.00	
	3/4"	0	EA	0.36	0	\$1.24	\$0.00	
	7/8"	0	EA	0.39	0	\$0.98	\$0.00	
	1 1/8"	0	EA	0.46	0	\$1.60	\$0.00	
	1 3/8"	0	EA	0.52	0	\$2.86	\$0.00	
	1 5/8"	0	EA	0.59	0	\$3.80	\$0.00	
	2 1/8"	0	EA	0.65	0	\$6.28	\$0.00	
COPPER ELLS								
	3/8"	10	EA	0.26	2.6	\$1.70	\$17.00	
	1/2"	0	EA	0.29	0	\$3.01	\$0.00	
	5/8"	10	EA	0.33	3.3	\$2.00	\$20.00	
	3/4"	0	EA	0.36	0	\$2.49	\$0.00	
	7/8"	0	EA	0.39	0	\$3.30	\$0.00	
	1 1/8"	0	EA	0.46	0	\$5.06	\$0.00	
	1 3/8"	0	EA	0.52	0	\$8.67	\$0.00	
	1 5/8"	0	EA	0.59	0	\$11.59	\$0.00	
	2 1/8"	0	EA	0.65	0	\$32.97	\$0.00	
SIGHT GLASSES								
	3/8"	1	EA	0.38	0.38	\$14.00	\$14.00	
	1/2"	0	EA	0.38	0	\$17.00	\$0.00	
	5/8"	0	EA	0.45	0	\$18.00	\$0.00	
	3/4"	0	EA	0.45	0	\$20.00	\$0.00	
	7/8"	0	EA	0.53	0	\$22.00	\$0.00	
SOLINOID VALVES								
	3/8"	0	EA	0.38	0	\$74.60	\$0.00	
	1/2"	0	EA	0.38	0	\$84.87	\$0.00	
	5/8"	0	EA	0.45	0	\$103.08	\$0.00	
	3/4"	0	EA	0.45	0	\$120.87	\$0.00	
	7/8"	0	EA	0.53	0	\$144.83	\$0.00	
SOLINOID COILS								
	3/8" THROUGH 7/8"	0	EA	0.08	0	\$22.00	\$0.00	
HANGERS EVERY 6 FT								
	CLEVIS AND TRAPEZE	10	EA	0.15	1.5	\$16.50	\$165.00	

EXTRA FREON								
R-22			0	EA	0	0	\$4.00	\$0.00
R-410A			4	EA	0	0	\$9.75	\$39.00
SOLDER MATERIAL								
8	20	3/8" THROUGH 5/8"	28	EA	0	0	\$0.30	\$8.40
0	0	3/4" THROUGH 1 1/8"	0	EA	0	0	\$1.00	\$0.00
0	0	1 3/8" THROUGH 2 1/8"	0	EA	0	0	\$1.35	\$0.00
ARMAFLEX BY 1/2"								
3/8"			0	FT	0.01	0	\$0.33	\$0.00
1/2"			0	FT	0.01	0	\$0.29	\$0.00
5/8"			0	FT	0.01	0	\$0.29	\$0.00
3/4"			0	FT	0.01	0	\$0.27	\$0.00
7/8"			0	FT	0.01	0	\$0.33	\$0.00
1 1/8"			0	FT	0.01	0	\$0.37	\$0.00
1 3/8"			0	FT	0.01	0	\$0.56	\$0.00
1 5/8"			0	FT	0.01	0	\$0.66	\$0.00
2 1/8"			0	FT	0.01	0	\$0.83	\$0.00
ARMAFLEX BY 1"								
3/8"			60	FT	0.01	0.6	\$0.90	\$54.00
1/2"			0	FT	0.01	0	\$0.78	\$0.00
5/8"			60	FT	0.01	0.6	\$0.65	\$39.00
3/4"			0	FT	0.01	0	\$0.78	\$0.00
7/8"			0	FT	0.01	0	\$0.84	\$0.00
1 1/8"			0	FT	0.01	0	\$0.90	\$0.00
1 3/8"			0	FT	0.01	0	\$1.98	\$0.00
1 5/8"			0	FT	0.01	0	\$2.23	\$0.00
2 1/8"			0	FT	0.01	0	\$2.74	\$0.00
ARMAFLEX BY 1-1/2"								
5/8"			0	FT	0.02	0	\$2.54	\$0.00
3/4"			0	FT	0.02	0	\$2.75	\$0.00
7/8"			0	FT	0.02	0	\$3.26	\$0.00
1 1/8"			0	FT	0.02	0	\$3.86	\$0.00
1 3/8"			0	FT	0.02	0	\$3.98	\$0.00
REFRIGERATION / PIPING LABOR						17.3	M-TOTAL	\$492.40

TRAVEL						
TOTAL HOURS DEVIDED BY 24 = TRIPS	TRIPS	MAN HOURS PER ROUND TRIP	TRAVEL MILES PER ME/HOU	TRIP	TRAVEL	
	1	0	0	0		\$0.00



Vaughn Construction
 Mr. Doug Boram
 3920 North IH 35
 Austin, Texas 78751

January 5, 2018

**Reference: Williamson County North Campus Facility
 Electrical Proposal PCO- 018
 Install power for the new mini split in the North stairwell. ASI-035**

We are pleased to provide the following proposal for the additional work as requested by Vaughn Construction.

Total Cost **\$ 5,898.00**
Five-Thousand Eight-Hundred and Ninety-Eighty dollars

Inclusions:

<u>Item No.</u>	<u>Description</u>
1	Install new conduit, conductors for the mini split unit at the North stairwell.
2	Install one 30A/2P/F N3R disconnect on the roof and one motor rated switch at the inside unit.
3	Install a raceway for control wiring through the roof.

Qualifications:

Price is firm for 30 days from the date of this proposal.

Exclude all sealing of roof penetrations.

Exclude all sheetrock patching and painting.

If you have any questions, please feel free to call me at 512-369-5551.

Sincerely,

Schmidt Electric Company

Scott Schwartz
Project Manager

Accepted By

Date

cc: File



Williamson County Facilities - Job Cost Tracking Log

Project: North Campus Project # P324

Change Order #: 43

Change Order No.	Court Agenda Date	Party of Initiation	Time Ext. (Days)	GMP Breakdown						GMP Total	Total Updated Contract Amount
				Cost of Work	CM Contingency	Owner Contingency	Buyout Savings (Current)	General Conditions	Construction Phase Fee		
Contract				\$ 18,027,145.00	\$ 406,771.00	\$ 406,772.00	\$ -	\$ 1,896,522.00	\$ 625,467.00	\$ 21,362,677.00	\$ 21,362,677.00
1	03/28/17		0	\$ 3,659.00	\$ -	\$ (3,659.00)	\$ -	\$ -	\$ -	\$ -	\$ 21,362,677.00
2	03/28/17		10	\$ 114,186.00	\$ -	\$ (114,186.00)	\$ -	\$ -	\$ -	\$ -	\$ 21,362,677.00
3	05/02/17		0	\$ 1,727.00	\$ -	\$ (1,727.00)	\$ -	\$ -	\$ -	\$ -	\$ 21,362,677.00
4	05/02/17		0	\$ 19,494.00	\$ -	\$ (19,494.00)	\$ -	\$ -	\$ -	\$ -	\$ 21,362,677.00
5	05/30/17		0	\$ 19,676.00	\$ (19,676.00)	\$ -	\$ -	\$ -	\$ -	\$ -	\$ 21,362,677.00
6	05/30/17		0	\$ 14,465.00	\$ (14,465.00)	\$ -	\$ -	\$ -	\$ -	\$ -	\$ 21,362,677.00
7	05/30/17		0	\$ 2,237.00	\$ -	\$ (2,237.00)	\$ -	\$ -	\$ -	\$ -	\$ 21,362,677.00
8	05/30/17		0	\$ 3,450.00	\$ -	\$ (3,450.00)	\$ -	\$ -	\$ -	\$ -	\$ 21,362,677.00
9	06/27/17		0	\$ 832.00	\$ -	\$ (832.00)	\$ -	\$ -	\$ -	\$ -	\$ 21,362,677.00
10	06/27/17		0	\$ 285.00	\$ -	\$ (285.00)	\$ -	\$ -	\$ -	\$ -	\$ 21,362,677.00
11	06/27/17		0	\$ 22,415.00	\$ -	\$ (22,415.00)	\$ -	\$ -	\$ -	\$ -	\$ 21,362,677.00
12	06/27/17		0	\$ 11,221.00	\$ -	\$ (11,221.00)	\$ -	\$ -	\$ -	\$ -	\$ 21,362,677.00
13	06/27/17		0	\$ (5,000.00)	\$ -	\$ 5,000.00	\$ -	\$ -	\$ -	\$ -	\$ 21,362,677.00
14	06/27/17		0	\$ -	\$ -	\$ -	\$ -	\$ -	\$ -	\$ -	\$ 21,362,677.00
15	06/27/17		0	\$ 79,584.00	\$ -	\$ (79,584.00)	\$ -	\$ -	\$ -	\$ -	\$ 21,362,677.00
16	06/27/17		0	\$ 9,930.00	\$ -	\$ (9,930.00)	\$ -	\$ -	\$ -	\$ -	\$ 21,362,677.00
17	09/12/17	A&E	0	\$ 2,450.00	\$ -	\$ -	\$ (2,450.00)	\$ -	\$ -	\$ -	\$ 21,362,677.00
18	09/12/17	A&E	0	\$ 1,747.00	\$ (1,747.00)	\$ -	\$ -	\$ -	\$ -	\$ -	\$ 21,362,677.00
19	09/12/17	Owner	0	\$ 577,128.00	\$ -	\$ -	\$ (577,128.00)	\$ -	\$ -	\$ -	\$ 21,362,677.00
20	12/05/17	A&E	0	\$ 5,784.00	\$ -	\$ (5,856.00)	\$ -	\$ 72.00	\$ -	\$ -	\$ 21,362,677.00
21	10/03/17	A&E	0	\$ 10,364.00	\$ (10,364.00)	\$ -	\$ -	\$ -	\$ -	\$ -	\$ 21,362,677.00
22	10/03/17	A&E	0	\$ 6,461.00	\$ (6,461.00)	\$ -	\$ -	\$ -	\$ -	\$ -	\$ 21,362,677.00
23	12/05/17	A&E	0	\$ 15,825.00	\$ (15,825.00)	\$ -	\$ -	\$ -	\$ -	\$ -	\$ 21,362,677.00
24	10/03/17	A&E	0	\$ 33,906.00	\$ (33,906.00)	\$ -	\$ -	\$ -	\$ -	\$ -	\$ 21,362,677.00
25	10/03/17	A&E	0	\$ 8,854.00	\$ (8,854.00)	\$ -	\$ -	\$ -	\$ -	\$ -	\$ 21,362,677.00
26	02/06/18	A&E	0	\$ (106.00)	\$ -	\$ 106.00	\$ -	\$ -	\$ -	\$ -	\$ 21,362,677.00
27		A&E	0	\$ 2,687.00	\$ -	\$ (2,687.00)	\$ -	\$ -	\$ -	\$ -	\$ 21,362,677.00
28	PENDING REVIEW										\$ 21,362,677.00
29	02/06/18	A&E	0	\$ 3,647.00	\$ (3,647.00)	\$ -	\$ -	\$ -	\$ -	\$ -	\$ 21,362,677.00
30	10/24/17	Contractor		\$ (30,000.00)	\$ -	\$ 30,000.00	\$ -	\$ -	\$ -	\$ -	\$ 21,362,677.00
31	10/24/17	A&E		\$ 4,434.00	\$ -	\$ (4,434.00)	\$ -	\$ -	\$ -	\$ -	\$ 21,362,677.00
32	11/14/17	A&E		\$ 6,816.00	\$ -	\$ (6,816.00)	\$ -	\$ -	\$ -	\$ -	\$ 21,362,677.00
33	PENDING REVIEW										\$ 21,362,677.00
34	11/14/17	Contractor		\$ 5,273.00	\$ (5,273.00)	\$ -	\$ -	\$ -	\$ -	\$ -	\$ 21,362,677.00
35	PENDING REVIEW										\$ 21,362,677.00
36	12/05/17	A&E	0	\$ 1,280.00	\$ (1,280.00)	\$ -	\$ -	\$ -	\$ -	\$ -	\$ 21,362,677.00
37	12/05/17	A&E	0	\$ 1,601.00	\$ (1,601.00)	\$ -	\$ -	\$ -	\$ -	\$ -	\$ 21,362,677.00
38	PENDING REVIEW										\$ 21,362,677.00
39		Contractor	15	\$ -	\$ -	\$ -	\$ -	\$ -	\$ -	\$ -	\$ 21,362,677.00
40		Contractor	0	\$ (6,292.00)	\$ -	\$ 6,292.00	\$ -	\$ -	\$ -	\$ -	\$ 21,362,677.00
41	02/06/18	Owner	0	\$ (50,311.00)	\$ -	\$ 50,311.00	\$ -	\$ -	\$ -	\$ -	\$ 21,362,677.00
42		Contractor	0	\$ (44,494.00)	\$ -	\$ 44,494.00	\$ -	\$ -	\$ -	\$ -	\$ 21,362,677.00
43		Owner	0	\$ 24,129.00	\$ -	\$ (24,129.00)	\$ -	\$ -	\$ -	\$ -	\$ 21,362,677.00
							\$ -	\$ -	\$ -	\$ -	\$ 21,362,677.00
			25	\$ 18,906,489.00	\$ 283,672.00	\$ 230,033.00	\$ (579,578.00)	\$ 1,896,594.00	\$ 625,467.00	\$ 21,362,677.00	\$ 21,362,677.00

Commissioners Court - Regular Session

17.

Meeting Date: 02/27/2018

North Campus Facility P324 - Change Order 44

Submitted By: Gina Wrehsnig, Infrastructure

Department: Infrastructure

Division: Building Maintenance

Agenda Category: Consent

Information

Agenda Item

Discuss, consider and take appropriate action on accepting and approving a report on the Williamson County North Campus Project; Change Order #44 in the amount of \$4,882.00 for electrical modifications at warehouse per ASI-037, which was executed by Dwayne Gossett, Williamson County Facilities Project Manager, pursuant to the previous grant of authority under Section 262.031 of the Local Government Code. This change order is to be funded by the Owners Contingency.

Background

On September 6, 2016, the Williamson County Commissioners Court granted Dwayne Gossett, Williamson County Facilities Project Manager, with general authority to approve change orders for the Agreement for Construction Services with J. T. Vaughn Construction, LLC in relation to the Williamson County North Campus Project for any increase in costs up to a total maximum amount of \$30,000.00 in accordance with Section 262.031 of the Local Government Code – Changes in Plans and Specifications. This report is being provided for purposes of notifying the court of such change order and to place it in the minutes of the Commissioners Court.

Fiscal Impact

From/To	Acct No.	Description	Amount
---------	----------	-------------	--------

Attachments

[NCF Change Order 44](#)

[NCF CO44 Funds](#)

Form Review

Inbox

County Judge Exec Asst.

Form Started By: Gina Wrehsnig

Final Approval Date: 02/22/2018

Reviewed By

Wendy Coco

Date

02/22/2018 08:28 AM

Started On: 02/22/2018 07:59 AM



3171 SE Inner Loop
Georgetown, TX
78626

T: (512) 663-7461
F: (512) 681-9752

February 13, 2018

Dwayne Gossett
Williamson County, Texas
3101 SE Inner Loop
Georgetown, TX 78620

Re: North Campus Facilities

Job No: 233901

Subj: Change Proposal No. 233901-0044

Dear Sir or Madam:

We respectfully submit our proposal for an increase to our contract in the amount of \$0 (zero) dollars to provide Electrical Modifications at Warehouse per ASI-037 dated 1/5/2018 for the above referenced project.

Our price is valid for Ten (10) days

Please indicate your acceptance of this change proposal by signing and returning one copy of the attached Form B breakdown of our cost.

Very truly yours,
VAUGHN CONSTRUCTION

Doug Boram

Attachments: Form B, Subcontractor Pricing Back-up

CC: Brody Harris - BLGY
Mark Brown - BLGY

FORM B

PROJECT: North Campus Facilities

CHANGE PROPOSAL NO: 233901-0044

QUOTATION :

Item	Labor	Materials	Subs	Total
Electrical Modification at Warehouse per ASI-037	\$0.00	\$0.00	\$4,822.00	\$4,822.00
To Be Funded by Owners Contingency	\$0.00	\$(4,882.00)	\$0.00	\$(4,882.00)
Vaughn Subcontractor Default Insurance	\$0.00	\$0.00	\$60.00	\$60.00

Totals	\$0.00	\$(4,882.00)	\$4,882.00	\$0.00
				Insurance, Tax, Benefits on Labor \$0.00
				Overhead \$0.00
				Fee on Subs \$0.00
				Fee on JTV \$0.00
				Bond \$0.00
				Remodel Tax \$0.00
TOTAL				\$0.00

TIME EXTENSION TO CONTRACT: 0 Days

Submitted Date: 2/13/2018

Accepted

VAUGHN CONSTRUCTION

By: 

By: 
Doug Boram

Date _____

Proposal Valid for 10 Days

Williamson County
 Williamson County North Campus Facilities
 Vaughn Project No. 2339-01



Funds Tracking Log

Change Proposal No.	Change Type & No.	Time Extension (Days)		GMP Breakdown						GMP #2339.01	Total Updated Contract Amount
		Pending	Approved	Cost of Work	CM Contingency	Owner Contingency	General Conditions	Buyout Savings	Construction Phase Fee		
N/A	GMP	-	-	\$18,195,395	\$406,771	\$406,772	\$1,896,522		\$625,467	\$21,530,927	\$21,530,927
1	OCO	0	0	\$3,659	\$0	(\$3,659)	\$0		\$0	\$0	\$21,530,927
2	OCO	10	10	\$114,186	\$0	(\$114,186)	\$0		\$0	\$0	\$21,530,927
3	OCO	0	0	\$1,727	\$0	(\$1,748)	\$21		\$0	\$21	\$21,530,948
4	OCO	0	0	\$19,494	\$0	(\$19,494)	\$0		\$0	\$0	\$21,530,948
5	OCO	0	0	\$19,676	(\$19,676)	\$0	\$0		\$0	\$0	\$21,530,948
6	OCO	0	0	\$14,465	(\$14,465)	\$0	\$0		\$0	\$0	\$21,530,948
7	OCO	0	0	\$2,237	\$0	(\$2,237)	\$0		\$0	\$0	\$21,530,948
8	OCO	0	0	\$3,450	\$0	(\$3,450)	\$0		\$0	\$0	\$21,530,948
9	OCO	0	0	\$832	\$0	(\$832)	\$0		\$0	\$0	\$21,530,948
10	OCO	0	0	\$285	\$0	(\$285)	\$0		\$0	\$0	\$21,530,948
11	OCO	0	0	\$22,415	\$0	(\$22,415)	\$0		\$0	\$0	\$21,530,948
12	OCO	0	0	\$11,221	\$0	(\$11,221)	\$0		\$0	\$0	\$21,530,948
13	OCO	0	0	(\$5,000)	\$0	\$5,000	\$0		\$0	\$0	\$21,530,948
14	OCO	0	0	\$0	\$0	\$0	\$0		\$0	\$0	\$21,530,948
15	OCO	0	0	\$79,584	\$0	(\$79,584)	\$0		\$0	\$0	\$21,530,948
16	OCO	0	0	\$9,930	\$0	(\$9,930)	\$0		\$0	\$0	\$21,530,948
17	OCO	0	0	\$2,450	(\$2,450)	\$0	\$0		\$0	\$0	\$21,530,948
18	OCO	0	0	\$1,747	(\$1,747)	\$0	\$0		\$0	\$0	\$21,530,948
19	OCO	0	0	(\$1,763)	\$0	\$0	\$1,763		\$0	\$0	\$21,530,948
20	OCO	0	0	\$5,784	\$0	(\$5,856)	\$72		\$0	\$72	\$21,531,020
21	OCO	0	0	\$10,364	(\$10,364)	\$0	\$0		\$0	\$0	\$21,531,020
22	OCO	0	0	\$6,410	(\$6,461)	\$0	\$51		\$0	\$0	\$21,531,020
23	OCO	0	0	\$15,825	(\$15,825)	\$0	\$0		\$0	\$0	\$21,531,020
24	OCO	0	0	\$33,487	(\$33,906)	\$0	\$419		\$0	\$0	\$21,531,020
25	OCO	0	0	\$8,854	(\$8,854)	\$0	\$0		\$0	\$0	\$21,531,020
26	OCO	0	-	(\$106)	\$0	\$106	\$0		\$0	\$0	\$21,531,020
27R	OCO	0	-	\$2,687	\$0	(\$2,687)	\$0		\$0	\$0	\$21,531,020
28	Void	0	0	\$0	\$0	\$0	\$0		\$0	\$0	\$21,531,020
29	OCO	0	-	\$3,647	(\$3,647)	\$0	\$0		\$0	\$0	\$21,531,020
30	OCO	0	0	(\$30,000)	\$0	\$30,000	\$0		\$0	\$0	\$21,531,020
31	OCO	0	0	\$4,434	\$0	(\$4,434)	\$0		\$0	\$0	\$21,531,020

32	OCO	0	0	\$6,816	\$0	(\$6,816)	\$0	\$0	\$0	\$0	\$21,531,020
33R	OCO	0	-	(\$28,265)	\$0	\$28,265	\$0	\$0	\$0	\$0	\$21,530,927
34	OCO	0	0	\$5,273	(\$5,273)	\$0	\$0	\$0	\$0	\$0	\$21,531,020
35	OCO	0	0	(\$168,250)	\$0	\$0	\$0	\$0	\$0	(\$168,250)	\$21,362,770
36	OCO	0	0	\$1,280	(\$1,280)	\$0	\$0	\$0	\$0	\$0	\$21,531,020
37	OCO	0	0	\$1,601	(\$1,601)	\$0	\$0	\$0	\$0	\$0	\$21,531,020
38R	OCO	0	-	\$4,646	(\$4,646)	\$0	\$0	\$0	\$0	\$0	\$21,531,020
39R	OCO	10	-	\$0	\$0	\$0	\$0	\$0	\$0	\$0	\$21,531,020
40R	OCO	0	-	(\$6,292)	\$0	\$6,292	\$0	\$0	\$0	\$0	\$21,531,020
41	OCO	0	-	(\$50,311)	\$0	\$50,311	\$0	\$0	\$0	\$0	\$21,531,020
42R	OCO	0	-	(\$44,494)	\$0	\$44,494	\$0	\$0	\$0	\$0	\$21,531,020
43R	OCO	0	-	\$24,129	\$0	(\$24,129)	\$0	\$0	\$0	\$0	\$21,531,020
44R	OCO	0	-	\$4,882	\$0	(\$4,882)	\$0	\$0	\$0	\$0	\$21,531,020
Current Amounts		20	10	\$18,308,391	\$276,576	\$253,395	\$1,898,848	\$0	\$625,467	\$21,362,770	\$21,362,770



Vaughn Construction
 Mr. Doug Boram
 3920 North IH 35
 Austin, Texas 78751

January 12, 2018

Reference: Williamson County North Campus Facility
 Electrical Proposal PCO- 019
 ASI-37

We are pleased to provide the following proposal for the additional work as requested by Vaughn Construction.

Total Cost:	\$ 2,411.00
	Two-Thousand Four-Hundred and Eleven dollars
L6-30R receptacles in BLDG. H:	\$ 3,511.00
IR Heater deduct in BLDG. D:	(\$ 1,100.00)

Inclusions:

<u>Item No.</u>	<u>Description</u>
1	Delete conduit, conductors and 9 j-boxes for IR heaters in building D. Note: Conduit and conductors are installed from the panelboard to the j-box at the warehouse wall.
2	Install two L6-30R receptacles in the warehouse. One by room h136 and one by the coiling overhead door.

Qualifications:

Price is firm for 30 days from the date of this proposal.

Exclude all sheetrock patching and painting.

If you have any questions, please feel free to call me at 512-369-5551.

Sincerely,

Schmidt Electric Company

Scott Schwartz
Project Manager

Accepted By

Date

cc: File



Electrical Proposal
 Texas Electrical Contractors License Number 17947

Williamson County Facilities - Job Cost Tracking Log

Project: North Campus Project # P324

Change Order #: 44

Change Order No.	Court Agenda Date	Party of Initiation	Time Ext. (Days)	GMP Breakdown						GMP Total	Total Updated Contract Amount
				Cost of Work	CM Contingency	Owner Contingency	Buyout Savings (Current)	General Conditions	Construction Phase Fee		
Contract				\$ 18,027,145.00	\$ 406,771.00	\$ 406,772.00	\$ -	\$ 1,896,522.00	\$ 625,467.00	\$ 21,362,677.00	\$ 21,362,677.00
1	03/28/17		0	\$ 3,659.00	\$ -	\$ (3,659.00)	\$ -	\$ -	\$ -	\$ -	\$ 21,362,677.00
2	03/28/17		10	\$ 114,186.00	\$ -	\$ (114,186.00)	\$ -	\$ -	\$ -	\$ -	\$ 21,362,677.00
3	05/02/17		0	\$ 1,727.00	\$ -	\$ (1,727.00)	\$ -	\$ -	\$ -	\$ -	\$ 21,362,677.00
4	05/02/17		0	\$ 19,494.00	\$ -	\$ (19,494.00)	\$ -	\$ -	\$ -	\$ -	\$ 21,362,677.00
5	05/30/17		0	\$ 19,676.00	\$ (19,676.00)	\$ -	\$ -	\$ -	\$ -	\$ -	\$ 21,362,677.00
6	05/30/17		0	\$ 14,465.00	\$ (14,465.00)	\$ -	\$ -	\$ -	\$ -	\$ -	\$ 21,362,677.00
7	05/30/17		0	\$ 2,237.00	\$ -	\$ (2,237.00)	\$ -	\$ -	\$ -	\$ -	\$ 21,362,677.00
8	05/30/17		0	\$ 3,450.00	\$ -	\$ (3,450.00)	\$ -	\$ -	\$ -	\$ -	\$ 21,362,677.00
9	06/27/17		0	\$ 832.00	\$ -	\$ (832.00)	\$ -	\$ -	\$ -	\$ -	\$ 21,362,677.00
10	06/27/17		0	\$ 285.00	\$ -	\$ (285.00)	\$ -	\$ -	\$ -	\$ -	\$ 21,362,677.00
11	06/27/17		0	\$ 22,415.00	\$ -	\$ (22,415.00)	\$ -	\$ -	\$ -	\$ -	\$ 21,362,677.00
12	06/27/17		0	\$ 11,221.00	\$ -	\$ (11,221.00)	\$ -	\$ -	\$ -	\$ -	\$ 21,362,677.00
13	06/27/17		0	\$ (5,000.00)	\$ -	\$ 5,000.00	\$ -	\$ -	\$ -	\$ -	\$ 21,362,677.00
14	06/27/17		0	\$ -	\$ -	\$ -	\$ -	\$ -	\$ -	\$ -	\$ 21,362,677.00
15	06/27/17		0	\$ 79,584.00	\$ -	\$ (79,584.00)	\$ -	\$ -	\$ -	\$ -	\$ 21,362,677.00
16	06/27/17		0	\$ 9,930.00	\$ -	\$ (9,930.00)	\$ -	\$ -	\$ -	\$ -	\$ 21,362,677.00
17	09/12/17	A&E	0	\$ 2,450.00	\$ -	\$ -	\$ (2,450.00)	\$ -	\$ -	\$ -	\$ 21,362,677.00
18	09/12/17	A&E	0	\$ 1,747.00	\$ (1,747.00)	\$ -	\$ -	\$ -	\$ -	\$ -	\$ 21,362,677.00
19	09/12/17	Owner	0	\$ 577,128.00	\$ -	\$ -	\$ (577,128.00)	\$ -	\$ -	\$ -	\$ 21,362,677.00
20	12/05/17	A&E	0	\$ 5,784.00	\$ -	\$ (5,856.00)	\$ -	\$ 72.00	\$ -	\$ -	\$ 21,362,677.00
21	10/03/17	A&E	0	\$ 10,364.00	\$ (10,364.00)	\$ -	\$ -	\$ -	\$ -	\$ -	\$ 21,362,677.00
22	10/03/17	A&E	0	\$ 6,461.00	\$ (6,461.00)	\$ -	\$ -	\$ -	\$ -	\$ -	\$ 21,362,677.00
23	12/05/17	A&E	0	\$ 15,825.00	\$ (15,825.00)	\$ -	\$ -	\$ -	\$ -	\$ -	\$ 21,362,677.00
24	10/03/17	A&E	0	\$ 33,906.00	\$ (33,906.00)	\$ -	\$ -	\$ -	\$ -	\$ -	\$ 21,362,677.00
25	10/03/17	A&E	0	\$ 8,854.00	\$ (8,854.00)	\$ -	\$ -	\$ -	\$ -	\$ -	\$ 21,362,677.00
26	02/06/18	A&E	0	\$ (106.00)	\$ -	\$ 106.00	\$ -	\$ -	\$ -	\$ -	\$ 21,362,677.00
27		A&E	0	\$ 2,687.00	\$ -	\$ (2,687.00)	\$ -	\$ -	\$ -	\$ -	\$ 21,362,677.00
28	PENDING REVIEW										\$ 21,362,677.00
29	02/06/18	A&E	0	\$ 3,647.00	\$ (3,647.00)	\$ -	\$ -	\$ -	\$ -	\$ -	\$ 21,362,677.00
30	10/24/17	Contractor		\$ (30,000.00)	\$ -	\$ 30,000.00	\$ -	\$ -	\$ -	\$ -	\$ 21,362,677.00
31	10/24/17	A&E		\$ 4,434.00	\$ -	\$ (4,434.00)	\$ -	\$ -	\$ -	\$ -	\$ 21,362,677.00
32	11/14/17	A&E		\$ 6,816.00	\$ -	\$ (6,816.00)	\$ -	\$ -	\$ -	\$ -	\$ 21,362,677.00
33	PENDING REVIEW										\$ 21,362,677.00
34	11/14/17	Contractor		\$ 5,273.00	\$ (5,273.00)	\$ -	\$ -	\$ -	\$ -	\$ -	\$ 21,362,677.00
35	PENDING REVIEW										\$ 21,362,677.00
36	12/05/17	A&E	0	\$ 1,280.00	\$ (1,280.00)	\$ -	\$ -	\$ -	\$ -	\$ -	\$ 21,362,677.00
37	12/05/17	A&E	0	\$ 1,601.00	\$ (1,601.00)	\$ -	\$ -	\$ -	\$ -	\$ -	\$ 21,362,677.00
38	PENDING REVIEW										\$ 21,362,677.00
39		Contractor	15	\$ -	\$ -	\$ -	\$ -	\$ -	\$ -	\$ -	\$ 21,362,677.00
40		Contractor	0	\$ (6,292.00)	\$ -	\$ 6,292.00	\$ -	\$ -	\$ -	\$ -	\$ 21,362,677.00
41	02/06/18	Owner	0	\$ (50,311.00)	\$ -	\$ 50,311.00	\$ -	\$ -	\$ -	\$ -	\$ 21,362,677.00
42		Contractor	0	\$ (44,494.00)	\$ -	\$ 44,494.00	\$ -	\$ -	\$ -	\$ -	\$ 21,362,677.00
43		Owner	0	\$ 24,129.00	\$ -	\$ (24,129.00)	\$ -	\$ -	\$ -	\$ -	\$ 21,362,677.00
44		Owner	0	\$ 4,882.00	\$ -	\$ (4,882.00)	\$ -	\$ -	\$ -	\$ -	\$ 21,362,677.00
				\$ -	\$ -	\$ -	\$ -	\$ -	\$ -	\$ -	\$ 21,362,677.00
			25	\$ 18,911,371.00	\$ 283,672.00	\$ 225,151.00	\$ (579,578.00)	\$ 1,896,594.00	\$ 625,467.00	\$ 21,362,677.00	\$ 21,362,677.00

Commissioners Court - Regular Session

18.

Meeting Date: 02/27/2018

Jail Remodel Project P411 - Change Order 3

Submitted By: Gina Wrehsnig, Infrastructure

Department: Infrastructure

Division: Building Maintenance

Agenda Category: Consent

Information

Agenda Item

Discuss, consider and take appropriate action on accepting and approving a report on the Jail Kitchen and Plumbing Remodel Project; Change Order # 3 in the amount of \$49,389.05 for additional HVAC and plumbing work, and safety upgrades associated with unforeseen conditions and safety items that were upgraded from the original specifications, which was executed by Dale Butler, Williamson County Facilities Project Manager, pursuant to the previous grant of authority under Section 262.031 of the Local Government Code. This change order is being funded out of the Owners Contingency.

Background

On August 15, 2017, the Williamson County Commissioners Court granted Dale Butler, Williamson County Facilities Project Manager, with general authority to approve change orders for the Agreement for Construction Services with STR Constructors, Ltd. in relation to the Williamson County Jail Kitchen and Plumbing Remodel Project for any increase in costs up to a total maximum amount of \$50,000.00 in accordance with Section 262.031 of the Local Government Code – Changes in Plans and Specifications. This report is being provided for purposes of notifying the court of such change order and to place it in the minutes of the Commissioners Court.

Fiscal Impact

From/To	Acct No.	Description	Amount
---------	----------	-------------	--------

Attachments

Jail Change Order 3

Jail CO3 Funds

Form Review

Inbox

County Judge Exec Asst.

Form Started By: Gina Wrehsnig

Final Approval Date: 02/22/2018

Reviewed By

Wendy Coco

Date

02/22/2018 08:28 AM

Started On: 02/22/2018 08:07 AM



WILLIAMSON COUNTY, TEXAS
 FACILITIES DEPARTMENT
 3101 SE Inner Loop
 Georgetown, TX 78626
 512-943-1609

CHANGE ORDER

For Project: WILLIAMSON COUNTY JAIL KITCHEN & PLUMBING REMODEL
 Date of Issuance: 2/12/2018 Change Order No: 3
 Contractor: STR Constructors, LTD. PID: _____
 Project Engineer: Talex, Inc.

Explanation:

This change order is due to the following:

- PCO #7 - Add 40ea 8ft Corner Guards in Kitchen (includes removal of 14ea existing 4ft)
- PCO #10 - Add Stainless Wainscoting & bumper rail to Kitchen Knee wall near Dishwashing
- PCO-11 - Add to Upgrade Resinous Floor Surface to Anti-Slip
- PCO-13 Add for AHU-01 Duct Rerouting & associate work
- PCO-16 - Add for Epoxy Pipe "Blow-Out" Repairs, to date
- PCO-17 - Add for Kitchen Resinous Floor COLOR Upgrade (BLUE)

Description of Work:	Cost
See attached PCO #07	\$ 8,532.40
See attached PCO #10	\$ 9,759.43
See attached PCO #11	\$ 17,105.55
See attached PCO #13	\$ 6,687.44
See attached PCO #16	\$ 5,049.16
See attached PCO #17	\$ 2,255.07
Weather Days -	
Sub-Total CO #3	\$ 49,389.05

Additional Time		KITCHEN AREA	OVERALL PROJECT
0	Days	0	Days
0	Days	0	Days
2	Days	2	Days
0	Days	0	Days
0	Days	0	Days
0	Days	0	Days
			0 Days
		2 Days	2 Days

Please Refer to Attached Backup Documents:

Cost and Time Change Summary

	Cost
Original Contract:	\$ 1,781,645.00
Previous Change Order(s):	\$ 161,116.50
Contract Prior to this CO:	\$ 1,942,761.50
Net Increase from this CO:	\$ 49,389.05
Revised Contract Total:	\$ 1,992,150.55

Additional Time		KITCHEN AREA	OVERALL PROJECT
120	Days	180	Days
8	Days	18	Days
128	Days	198	Days
2	Days	2	Days
130	Days	200	Days

RECOMMENDED BY:

 Contractor Signature*
Oscar Villarreal
 Engineer Signature

T. R. Kennedy, President
 Contractor Name
 Oscar Villarreal, P.E.
 Engineer Name

02/12/18
 Signature Date
 2/13/18
 Signature Date

ACCEPTED BY:

 Owner Signature

Dale Bulter, Asst Dir - Projects
 Owners' Rep Name

2/13/18
 Signature Date

*By Signing this change order the Contractor accepts the changes herein and agrees to perform the change(s) for the price and time indicated. The prices include all costs to perform the work.
 No work shall be done until this change order is executed. No payment to the Contractor (or Consultant) shall be made for work included in this Change Order until Contractor's pay estimate is updated.
 In case of conflict between construction documents and this change order, this change order shall govern.
 Upon execution of this Change Order by all parties, the identified time and cost changes herein are made part of the contract documents.

STR CONSTRUCTORS, LTD.
CHANGE PROPOSAL

PROPOSAL ISSUED TO:		STR's PCO NO.: 07																																					
		Wilco Jail Kitchen & Plumbing Remodel 508 South Rock Street Georgetown, TX																																					
ATTENTION:		Dale Bulter Asst Director, Projects																																					
DESCRIPTION:																																							
Add for 8ft Stainless Steel Corner Guards (40ea) in accordance with ASI #2 Item #3																																							
Description	Subcontracts	Material	Labor	Total																																			
STR Constructor's Direct Costs																																							
		\$ -	\$ -	\$ -																																			
Removal of 14ea Existing 4ft Corner Guards		\$ 35.00		\$ 35.00																																			
STR Misc Labor (2men @ 1/2day)			\$ 200.00	\$ 200.00																																			
Subcontract Cost																																							
	Slater Div 10	\$7,189.20		\$ 7,189.20																																			
(prorated per the attached)																																							
<table style="width: 100%; border-collapse: collapse;"> <tr> <td style="width: 40%; padding: 2px;">DIRECT COST</td> <td style="width: 15%; padding: 2px;">\$ 7,189.20</td> <td style="width: 15%; padding: 2px;">\$ 35.00</td> <td style="width: 15%; padding: 2px;">\$ 200.00</td> <td style="width: 15%; padding: 2px;">\$ 7,424.20</td> </tr> <tr> <td style="padding: 2px;">PAYROLL TAX & INSURANCE (STR's Labor)</td> <td style="padding: 2px;">32.58%</td> <td></td> <td></td> <td style="padding: 2px;">\$ 65.16</td> </tr> <tr> <td style="padding: 2px;">STR FEE ON OWN WORK</td> <td style="padding: 2px;">15.00%</td> <td></td> <td></td> <td style="padding: 2px;">\$ 45.02</td> </tr> <tr> <td style="padding: 2px;">STR FEE ON SUBCONTRACTORS</td> <td style="padding: 2px;">10.00%</td> <td></td> <td></td> <td style="padding: 2px;">\$ 718.92</td> </tr> <tr> <td style="padding: 2px;">BOND</td> <td style="padding: 2px;">2.50%</td> <td></td> <td></td> <td style="padding: 2px;">\$ 206.34</td> </tr> <tr> <td style="padding: 2px;">INSURANCE</td> <td style="padding: 2px;">0.86%</td> <td></td> <td></td> <td style="padding: 2px;">\$ 72.76</td> </tr> <tr> <td style="padding: 2px;">TOTAL COST</td> <td></td> <td></td> <td></td> <td style="padding: 2px;">\$ 8,532.40</td> </tr> </table>					DIRECT COST	\$ 7,189.20	\$ 35.00	\$ 200.00	\$ 7,424.20	PAYROLL TAX & INSURANCE (STR's Labor)	32.58%			\$ 65.16	STR FEE ON OWN WORK	15.00%			\$ 45.02	STR FEE ON SUBCONTRACTORS	10.00%			\$ 718.92	BOND	2.50%			\$ 206.34	INSURANCE	0.86%			\$ 72.76	TOTAL COST				\$ 8,532.40
DIRECT COST	\$ 7,189.20	\$ 35.00	\$ 200.00	\$ 7,424.20																																			
PAYROLL TAX & INSURANCE (STR's Labor)	32.58%			\$ 65.16																																			
STR FEE ON OWN WORK	15.00%			\$ 45.02																																			
STR FEE ON SUBCONTRACTORS	10.00%			\$ 718.92																																			
BOND	2.50%			\$ 206.34																																			
INSURANCE	0.86%			\$ 72.76																																			
TOTAL COST				\$ 8,532.40																																			
QUALIFICATIONS & CLARIFICATIONS:																																							
<p>This change proposal becomes null & void after ten calendar days (10) and extends the contract completion date by 0 working days at \$ 1,058.40 dollars of cost for general conditions expenses per each calendar day. Work stoppage due to late acceptance of this change proposal voids this quotation and will increase the cost by the General Contractor's general conditions expenses which exceed (\$ 1,481.76) per work day. One Work day = 1.4 Calendar days.</p>																																							
STR CONSTRUCTORS, LTD.			Approved by:																																				
<i>TD Starfield</i>																																							
Project Manager	DATE:	<i>1/22/2018</i>	Date:																																				

Tom Stanfield

From: Erich <erich@slaterpainting.com>
Sent: Monday, January 08, 2018 2:52 PM
To: Tom Stanfield
Cc: James Weeks Jr
Subject: RE: WILCO Jail Renovation - ASI #2
Attachments: co-8p_mec.pdf

Follow Up Flag: Follow up
Flag Status: Flagged

26ea- Model CO8 Corner Guard, 3-1/2" x 8', Screw-On

Material and Labor= \$4,673.00 (no tax)

26ea = 179.73 EA

Erich de Bruyn
Project Manager/Estimator, Div. 10
Slater Painting Company, Inc.
9607 Gray Blvd
Austin, TX 78758
Office (512)451-4246 Ext. 212
Fax (512)452-3609
Cell (512)415-6246

X 40EA Correct Count
FIELD VERIFIED

A 7,189 20

From: Tom Stanfield [<mailto:toms@strconstructors.com>]
Sent: Friday, January 5, 2018 1:17 PM
To: Erich <erich@slaterpainting.com>
Cc: James Weeks Jr <lonewolf123@live.com>
Subject: FW: WILCO Jail Renovation - ASI #2

Erich,

Here is the ASI I texted you about.

See Scope of Work Item #3.

I come up with a count of 26ea.....the hood area is already all stainless as well as the two short walls

Tom

From: Oscar Villarreal [<mailto:oscar@talexinc.com>]
Sent: Thursday, January 04, 2018 9:23 AM
To: Dale Butler
Cc: Tom Stanfield
Subject: WILCO Jail Renovation - ASI #2

See attached ASI #2.

Oscar Villarreal, P.E., LEED AP

CORNER GUARD:
 FINISH: _____
 GAUGE: _____
 TYPE: _____
 CORNER GUARDS SUPPLIED IN STANDARD 16 GAUGE, TYPE #304 ALLOY WITH #4 SATIN FINISH.
 CORNER GUARDS ARE AVAILABLE WITH AN OPTIONAL POWDER COAT FINISH. PLEASE ADVISE OPTIONAL POWDER COAT FINISH IF REQUIRED.
 OPTIONAL GAUGE (14,18, 20) AND ALLOY TYPES (#316, #430) AVAILABLE. PLEASE ADVISE OPTIONAL GAUGE AND ALLOY TYPE IF REQUIRED.

UNITS REQ'D	UNIT HEIGHT

NOTES:

- CORNER GUARDS ARE SHIPPED WITH A PROTECTIVE STRIPPABLE COATING.

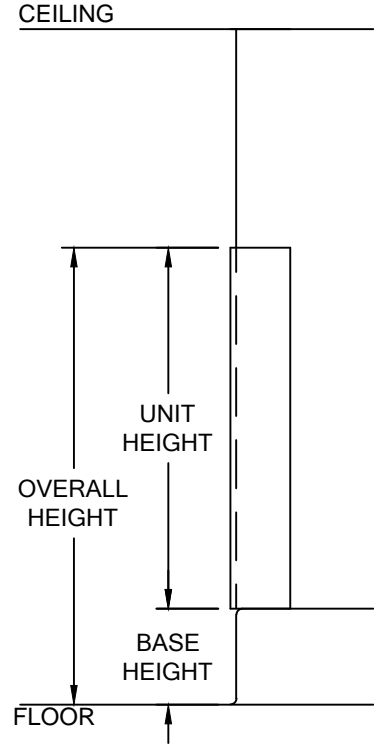
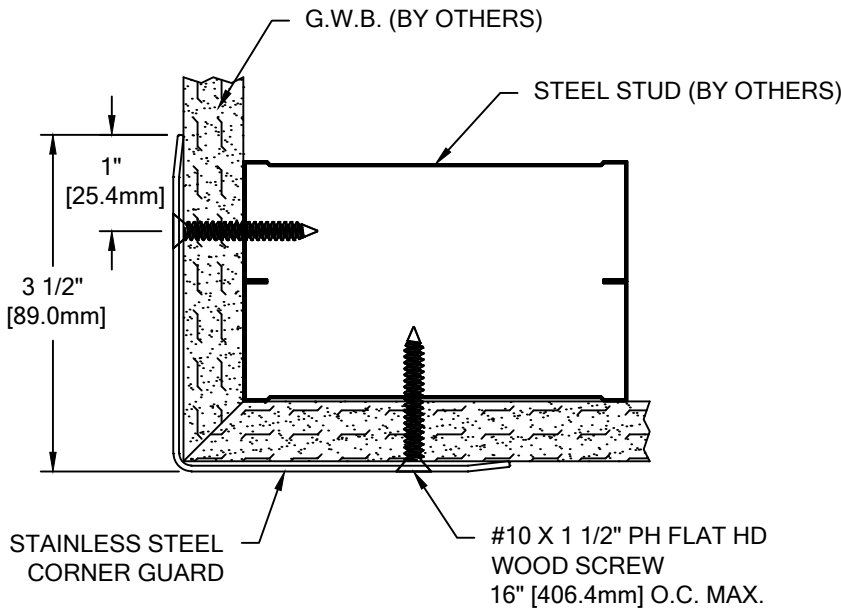

STAINLESS STEEL GUARD AT PARTIAL HEIGHT ELEVATION

CO-8 CORNER GUARD

WALL CONDITION	SPECIFIED FASTENER	DRILL DIAMETERS		C/S PART NUMBER
		WALL	RETAINER	
CONCRETE/CONCRETE BLOCK	#10 X 1 1/2" S/S PHILLIPS FLAT HEAD WOOD SCREW AF-8 PLASTIC ANCHORS	1/4"	N/A	90H009002 90H049004
STEEL STUD/GYPSUM WALL	#10 X 1 1/2" S/S PHILLIPS FLAT HEAD WOOD SCREW	N/A	N/A	90H009002
WOOD STUD/GYPSUM WALL	#10 X 1 1/2" S/S PHILLIPS FLAT HEAD WOOD SCREW	N/A	N/A	90H009002

 <p>Construction Specialties™ 6696 Route 405 Highway, Muncy PA 17756 (800) 233-8493 • Fax (570) 546-4692 • www.c-sgroup.com</p>	PROJECT:	REVISION:
	JOB NO.:	F&F:
	CUSTOMER:	
	REP:	DATE:
	DRAWN BY:	SHEET NO:

STR CONSTRUCTORS, LTD.
CHANGE PROPOSAL

PROPOSAL ISSUED TO:		STR's PCO NO.: 10		
		Wilco Jail Kitchen & Plumbing Remodel 508 South Rock Street Georgetown, TX		
ATTENTION:		Dale Bulter Asst Director, Projects		
DESCRIPTION: Add for Stainless Steel Wainscot Panels at the Dishwashing Knee Wall, per field direction in review of ASI #2 (Note: Stainless Steel only along long knee walls and DOES NOT wrap the columns at each end, per jobsite directives)				
Description	Subcontracts	Material	Labor	Total
STR Constructor's Direct Costs				
(see attached STR GC Breakdown)				
		\$ -	\$ -	\$ -
				\$ -
				\$ -
				\$ -
				\$ -
Subcontract Cost				
TX Metal Equipment - SS Wall panels	\$ 6,282.00			\$ 6,282.00
Slater Div 10 - Bump Guard	\$2,300.00			\$ 2,300.00
				\$ -
				\$ -
				\$ -
				\$ -
				\$ -
				\$ -
				\$ -
DIRECT COST	\$ 8,582.00	\$ -	\$ -	\$ 8,582.00
PAYROLL TAX & INSURANCE (STR's Labor)	32.58%			\$ -
STR FEE ON OWN WORK	15.00%			\$ -
STR FEE ON SUBCONTRACTORS	10.00%			\$ 858.20
BOND	2.50%			\$ 236.01
INSURANCE	0.86%			\$ 83.22
TOTAL COST				\$ 9,759.43
QUALIFICATIONS & CLARIFICATIONS:				
<p>This change proposal becomes null & void after ten calendar days (10) and extends the contract completion date by 0 working days at \$ 1,058.40 dollars of cost for general conditions expenses per each calendar day. Work stoppage due to late acceptance of this change proposal voids this quotation and will increase the cost by the General Contractor's general conditions expenses which exceed (\$ 1,481.76) per work day. One Work day = 1.4 Calendar days.</p>				
STR CONSTRUCTORS, LTD. <i>TD Starfield</i>			Approved by:	
Project Manager	DATE:	<i>1/25/2018</i>	Date:	



Quote

01/15/2018

Project:
PCO Williamson County Jail
Kitchen and Plumbing Rem
Add Wainscot to order

From:
Texas Metal Equipment Company
Matt Wenzel
6707 Mayard Road
Houston, TX 77041-2613
(713) 466-8722

Project Code: H6649MW

Job Reference Number: 1923

Item	Qty	Description	Sell	Sell Total
<u>6</u>	1 ea	WALL PANELING Custom Model No. WP-442 Custom Wall Paneling	\$6,282.00	\$6,282.00
	1 ea	WP-497 Custom Wall Paneling		
			ITEM TOTAL:	\$6,282.00
			Total	\$6,282.00

1) Changes detailed in this Change Order will not be made without a signed approved change order. Delay in processing this order can delay completion of this portion of work.

2) Unless otherwise accepted in writing, definitions of scope of work and responsibility of other trades listed in Base Bid apply to this change, including Final Connection by MEP Trades, and work listed as By Others will not be included in this total.

3) Pricing is valid for thirty (30) days for shipping in sixty (60) days. After lapse of thirty (30) days without written approval, pricing of change may be subject to change.

Acceptance: _____ Date: _____

Printed Name: _____

Project Grand Total: \$6,282.00

Tom Stanfield

From: Erich <erich@slaterpainting.com>
Sent: Monday, January 22, 2018 4:29 PM
To: Tom Stanfield
Subject: RE: Wilco Jail Kitchen - Wall Bumpers

79LF (3" or 4" width), 1" thick solid plastic to be used as wall bumpers

Furnish and Install= \$2,300.00

Erich de Bruyn
Project Manager/Estimator, Div. 10
Slater Painting Company, Inc.
9607 Gray Blvd
Austin, TX 78758
Office (512)451-4246 Ext. 212
Fax (512)452-3609
Cell (512)415-6246

From: Tom Stanfield [<mailto:toms@strconstructors.com>]
Sent: Monday, January 22, 2018 11:48 AM
To: Erich <erich@slaterpainting.com>
Subject: Wilco Jail Kitchen - Wall Bumpers
Importance: High

Erich,

How are you coming on the pricing for the Solid Plastic Wall bumper?

I would like to get that pricing submitted to the Owner for approval.

Tom Stanfield

Project Manager
STR Constructors, Ltd.
15500 Hwy 29 West
Liberty Hill, TX 78642
Phone (512) 515-0254, ext 223
Cell (512) 818-4180

Tom Stanfield

From: Steve Harman <steve@txmetalequip.com>
Sent: Monday, January 15, 2018 7:08 AM
To: Tom Stanfield; Stephen C. Trawnik
Cc: Jtraviolic@txmetalequip.com; Andrew Harman
Subject: RE: Wilco Jail Kitchen Remodel - Request for Proposal (Stainless Steel Wall Panels)

Tom,

Stephen will provide you a formal PCO for this work but the price will be \$6,282.00 for the two wall wainscoting as follows:

- (1) Wall 41'-6" x 4'-0 high
- (1) Wall 36'-10" x 4'-0" high

The material will be 14 ga Stainless steel with butt joints and a trim over the joints, screwed to wall. That is our typical wall panel construction for jail/prison work.

We would have to come measure for the final sizes prior to releasing to fabrication.

Lead time is around two weeks from being able to take dimensions.

Let me know if you need anything else.

Sincerely

Steve Harman

Texas Metal Equipment Company

Office (713)466-8722

Cell (832)771-4444

steve@txmetalequip.com

From: Tom Stanfield [<mailto:toms@strconstructors.com>]
Sent: Friday, January 12, 2018 2:05 PM
To: Stephen C. Trawnik <STrawnik@txmetalequip.com>
Cc: Steve Harman <steve@txmetalequip.com>; Jtraviolic@txmetalequip.com
Subject: Wilco Jail Kitchen Remodel - Request for Proposal (Stainless Steel Wall Panels)
Importance: High

Stephen

The Owner has asked us to provide a price to add Stainless Steel Wall Panels (4ft Wainscot) to both sides of the knee wall separating the Dishwashing Area from the General Kitchen

I have provided an enlarged plan of this area (see attached) with plan dimensions, but you should confirm these during your upcoming site visit to Field Verify the Cooler / Freezer Layouts.

They would like this SS to be as thick as practical (based on the install being inside a County Jail with Inmate Trustees providing the majority of the Kitchen Labor)

FYI....all the existing Freezer & Coolers have now been removed, so we are ready for your Field Verification Site Visit ASAP

Let me know if you should have any questions

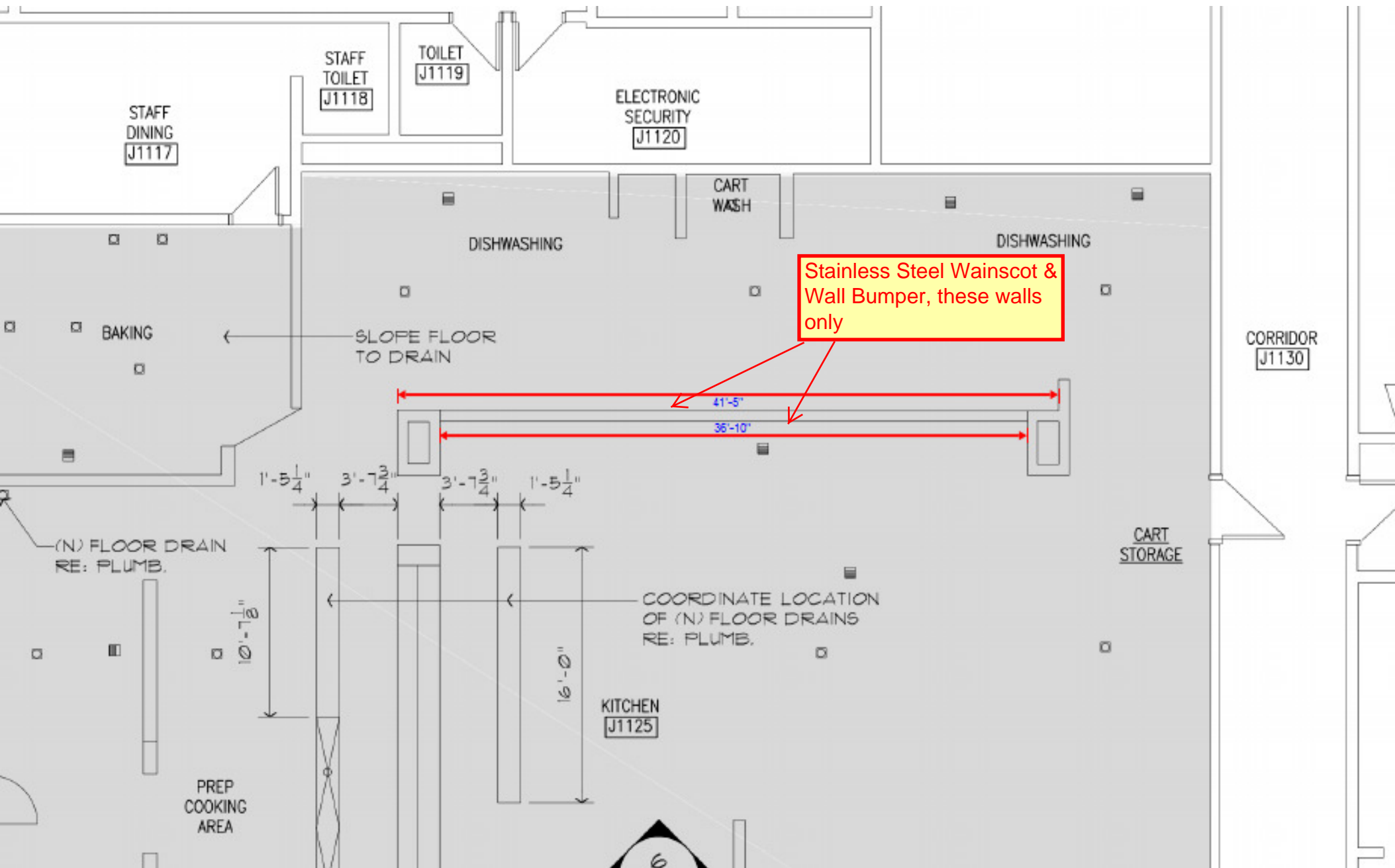

STR CONSTRUCTORS, LTD.
CHANGE PROPOSAL

PROPOSAL ISSUED TO:	STR's PCO NO.: 11			
	Wilco Jail Kitchen & Plumbing Remodel 508 South Rock Street Georgetown, TX			
ATTENTION:	Dale Bulter Asst Director, Projects			
DESCRIPTION:				
Add for kitchen Floor Surface Upgrade - to increase the Anti-Slip (Change from VerdeFloor HF previously submitted to VerdeFloor TC) Floor finish surface				
Description	Subcontracts	Material	Labor	Total
STR Constructor's Direct Costs				
(see attached STR GC Breakdown)		\$ 560.80	\$ 864.00	\$ 1,424.80
				\$ -
				\$ -
				\$ -
				\$ -
Subcontract Cost				
DLS Flooring Systems	\$ 13,258.00			\$ 13,258.00
				\$ -
				\$ -
				\$ -
				\$ -
				\$ -
				\$ -
				\$ -
				\$ -
				\$ -
DIRECT COST	\$ 13,258.00	\$ 560.80	\$ 864.00	\$ 14,682.80
PAYROLL TAX & INSURANCE (STR's Labor)	32.58%			\$ 281.49
STR FEE ON OWN WORK	15.00%			\$ 255.94
STR FEE ON SUBCONTRACTORS	10.00%			\$ 1,325.80
BOND	2.50%			\$ 413.66
INSURANCE	0.86%			\$ 145.86
TOTAL COST				\$ 17,105.55
QUALIFICATIONS & CLARIFICATIONS:				
<i>Per the attached subcontractor proposal, STR Constructors hereby also requests a <u>2 Calendar Day</u> time extension in the Kitchen Time associated with this additional work, as the flooring install is on the Project Critical Path</i>				
<p>This change proposal becomes null & void after ten calendar days (10) and extends the contract completion date by 2 working days at \$ 1,058.40 dollars of cost for general conditions expenses per each calendar day. Work stoppage due to late acceptance of this change proposal voids this quotation and will increase the cost by the General Contractor's general conditions expenses which exceed (\$ 1,481.76) per work day. One Work day = 1.4 Calendar days.</p>				
STR CONSTRUCTORS, LTD.			Approved by:	
<i>TD Starfield</i>				
Project Manager	DATE:	<i>1/30/2018</i>	Date:	



"Quality is Our Commitment"

4301 Reeder Drive, Suite 120 • Carrollton, Texas 75010 | P.O.Box 560367 • The Colony, Texas 75056
469.384.9859 Phone • 469.384.8473 Fax

CHANGE ORDER REQUEST

Company: STR Constructors, LTD
Contact: Tom Stanfield
Location: Williamson County Jail Kitchen
DLS Job Number: DLS0180315-001
Date of Change: 01/29/18
Request Submitted By: Todd Zeiler

Description of Change: Provide Increased Slip Resistance Application

Install and incorporate Verdia TC slip resistance quartz and lockcoat at 1/8" in thickness. The slip resistance for the system will increase by 200% and the final flooring thickness to an average of 3/8" or 33% more thickness. An additional 3-year warranty will be provided to Base Warranty. Application will add 2 days to our scope. Labor and materials

Total cost of expired product is \$13,258

Please call if you have any questions. We look forward to being of service.

Change Order Approved By: _____

Title: _____

Date: _____



VerdeFloor SF

Slurry Applied Heavy-Duty Polyurethane Concrete

VerdeFloor SF is a Heavy-Duty seamless flooring system typically installed at 1/4" finished thickness. VerdeFloor SF is tough and withstands thermal shock, impact, abrasion and chemical exposure. VerdeFloor SF offers various surface profiles to meet project requirements.

Recommended uses:

- Food & beverage processing facilities
- Commercial and industrial kitchens
- Bottling and packaging facilities
- Where steam and hot water is required
- Where a durable slip-resistant floor is needed

Unique features:

- Slip resistant finish, various profiles
- High temperature resistant to 200°F
- Excellent impact and abrasion resistance
- Resistant to wide range of chemicals

Benefits of VerdeFloor SF:

- Takes continuous hot-water cleaning
- Anti-slip surface, meets ADA recommendations
- Resistant to moisture vapor transmission (MVT)
- Outlasts typical epoxy overlays



Verdia Inc.

800-303-2557

info@verdia.com

Navigation

- Home
- Products
- Markets
- Bio-Based
- Contact Us

Choose the Right Flooring

- Food And Beverage Flooring
- Commercial Kitchen Flooring
- Manufacturing Flooring
- Pharmaceutical Flooring
- Aviation and Aerospace Flooring
- Warehouse Flooring

Our Products

- VerdeChem
- VerdeFloor
- VerdeCoat
- VerdeSeal
- VerdePatch

Who We Are

- Bio-Based Flooring
- Our Markets
- Contact Us

© 2017 Verdia, Inc.

STR CONSTRUCTORS, LTD.
CHANGE PROPOSAL

PROPOSAL ISSUED TO:		STR's PCO NO.: 13		
Wilco Jail Kitchen & Plumbing Remodel 508 South Rock Street Georgetown, TX				
ATTENTION:		Dale Bulter Asst Director, Projects		
DESCRIPTION:				
Add to Reroute AHU-01 supply & return ducting to avoid onsite conflicts				
Description	Subcontracts	Material	Labor	Total
STR Constructor's Direct Costs				\$ -
(see attached STR GC Breakdown)		\$ -	\$ -	\$ -
(Saw cut & wall block removal w bond beam (2men @ 12hr)		\$ 25.00	\$ 840.00	\$ 865.00
				\$ -
				\$ -
Subcontract Cost				\$ -
	Gemini Mech	\$ 3,936.00		\$ 3,936.00
				\$ -
American Drywall				\$ -
	(Addt Furr-Down above ice machines)	\$ 375.00		\$ 375.00
				\$ -
Capital Plumbing				\$ 379.20
	(Reroute water line to ice makers)			\$ -
				\$ -
				\$ -
				\$ -
DIRECT COST	\$ 4,690.20	\$ 25.00	\$ 840.00	\$ 5,555.20
PAYROLL TAX & INSURANCE (STR's Labor)	32.58%			\$ 273.67
STR FEE ON OWN WORK	15.00%			\$ 170.80
STR FEE ON SUBCONTRACTORS	10.00%			\$ 469.02
BOND	2.50%			\$ 161.72
INSURANCE	0.86%			\$ 57.03
TOTAL COST				\$ 6,687.44
QUALIFICATIONS & CLARIFICATIONS:				
<p>This change proposal becomes null & void after ten calendar days (10) and extends the contract completion date by 0 working days at \$ 1,058.40 dollars of cost for general conditions expenses per each calendar day. Work stoppage due to late acceptance of this change proposal voids this quotation and will increase the cost by the General Contractor's general conditions expenses which exceed (\$ 1,481.76) per work day. One Work day = 1.4 Calendar days.</p>				
STR CONSTRUCTORS, LTD.		Approved by:		
<i>TD Starfield</i>				
Project Manager	DATE:	<i>2/9/2018</i>	Date:	

Change Order Proposal



18 Indian Meadow Round Rock, Texas 78664 (512)244-3436 office (512) 244-3498 fax
TACLB00028659E

General Contractor: STR
Attn: Tom Stanfield

January 29, 2018

Re: AHU-1 Duct Modifications

We base our quotation attached document:

Scope of Work:

1. Extend 74 X 16" internally insulated return air ductwork from South wall of mechanical room J1124 into the large storage room J1147. Turn ductwork toward kitchen and extend to kitchen wall and terminate.
2. Add (1) 74 x 16 Titus Model 33RL heavy duty return grille at kitchen wall. Grille to be mounted using tamper proof stainless steel screws.
3. Seal ductwork
4. Reclaim refrigerant from ductless split system in J1147
5. Remove existing ductless split system and relocate approximately 5' and centered over door in storage room J1147.
6. Extend copper to new location of ductless split system
7. Extend condensate drain to relocated ductless split system.
8. Pressure test, vacuum, and recharge ductless split system.
9. Startup ductless split system
10. Clean up
11. Material handling and Trucking.
12. Labor and supervision.

Exclusions:

1. All cutting, coring, x-raying, patching or framing of walls, furrdowns, floors and roof for ductwork and piping penetrations.
2. Premium time
3. Sales tax.

<i>Materials:</i>	<i>\$2,502.00</i>
<i>Labor:</i>	<i>\$921.00</i>
<i>Sub Total:</i>	<i>\$3,423.00</i>
<i>15% O/M:</i>	<i>\$513.00</i>
<i>Total:</i>	<i>\$3,936.00</i>

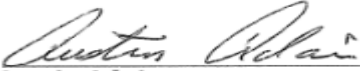
Austin Adair

Office Phone: (512) 244-3436 #213 / Mobile: (512) 999-8338
Email: ADAIR@GEMINIMECH.COM

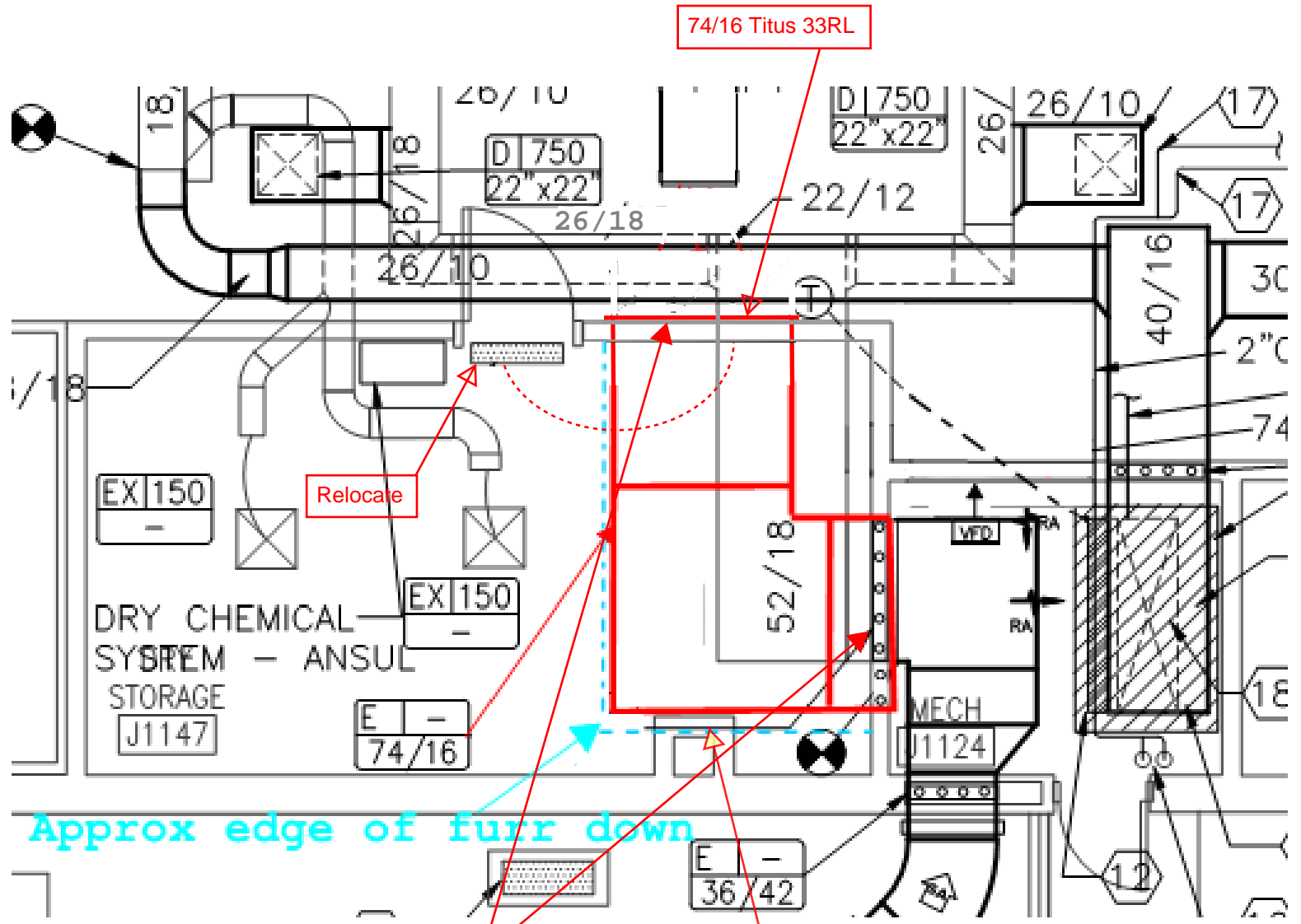

74/16 Titus 33RL

Relocate

Approx edge of furr down

76"W x 18"T Hole Locations

This added Furr-down is address in ASI 04 costs & NOT included in these costs

American Drywall Systems, Inc.

11821-A Buckner Road • Austin, Texas 78726
(512) 250-1666 Office • (512) 918-0770 Facsimile

CHANGE ORDER

Project: Williamson County Jail
Location: Georgetown, Texas
Contractor: STR Constructors
Attention: Tom Stanfield
Address: 15500 Hwy. 29 West
Liberty Hill, Texas

Date: 2-7-18
No:
Facsimile:
Deliver:
E-Mail x

Item	Description	Cost
	Price to install 2x4 Aluminum Cap Grid and 2 x 4 Ceramaguard Ceiling Tile to form a two foot drop due to duct re-routing. This is for additional furr-down required above Ice Machines, see sketch for supply duct re-route	
	Material:	\$220.00
	Labor:	\$155.00
	Total:	\$375.00

ATTENTION: THIS CHANGE ORDER MUST BE SIGNED AND RETURNED TO OUR OFFICE BEFORE ANY WORK RELATED TO IT WILL PROCEED:

AMERICAN DRYWALL SYSTEMS, INC.

We hereby agree to furnish all labor and materials for the additional work described above in accordance with the provisions of the original contract unless otherwise stipulated.

Signed:

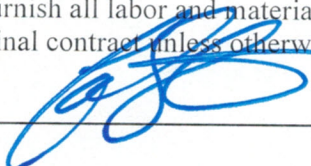

Date: 2-7-18

Accepted by:

Date:

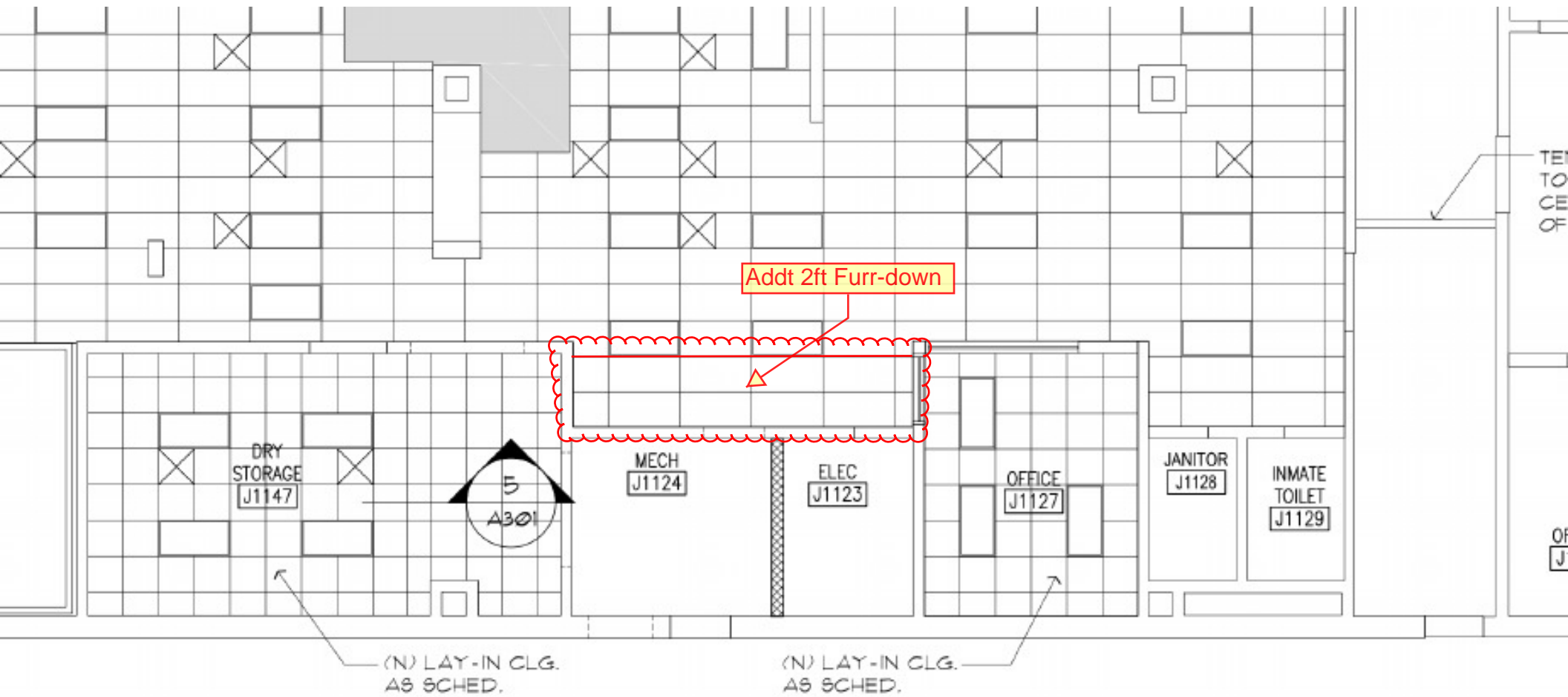

2 REFLECTED CEILING PLAN



1/8" = 1' - 0"

NOTE:
 AS AN ALTERNATE TO THE SCHEDULED LAY-IN SYSTEM FOR KITCHEN J1125. THE CONTRACTOR MAY, AT HIS DISCRETION OPT USE CERAMAGUARD FINE FISSURED 2'x4' LAY-IN TILE, PRELUDE PLUS XL ALUMINUM SUSPENSION SYSTEM W/ 414 RETENTION CLIP ARMSTRONG

Capitol Plumbing and Repair

CPR - "We bring your plumbing back to life"

401 CR 266, Georgetown TX 78628

Ph: 512-577-1262

Fax: 512-778-5554

e-mail: keith_cpr@yahoo.com

Change Order #3

To: STR Construction

Attn: Tom Stanfield

Project: Williamson County Jail

Description: Cap off and reroute water supply line for ice maker to allow ductwork to pass through cinder block wall.

Water supply line was discovered inside wall at the new duct penetration location

Materials: \$46

1 – 1/2" copper tee

1 – 1/2" copper 90

1 – 3/4" copper cap

1 – Solder, Flux, Sand, Gas

Labor: \$270.00

Plumber 3 hours @ \$90/hr

10% Overhead and Profit: \$63.20

Total: \$379.20

STR CONSTRUCTORS, LTD.
CHANGE PROPOSAL

PROPOSAL ISSUED TO:		STR's PCO NO.: 16		
Wilco Jail Kitchen & Plumbing Remodel				
508 South Rock Street				
Georgetown, TX				
ATTENTION:		Dale Bulter		
		Asst Director, Projects		
DESCRIPTION:				
Add for Misc Blowout Repairs during the Epoxy Coating Process, to Date				
Description	Subcontracts	Material	Labor	Total
STR Constructor's Direct Costs				\$ -
(see attached STR GC Breakdown)		\$ -	\$ -	\$ -
				\$ -
				\$ -
				\$ -
				\$ -
Subcontract Cost				\$ -
Specialized Plumbing Technologies				\$ -
(Add for Misc Blowout Repairs)	\$ 4,440.00			\$ 4,440.00
				\$ -
				\$ -
				\$ -
				\$ -
				\$ -
				\$ -
				\$ -
				\$ -
				\$ -
DIRECT COST	\$ 4,440.00	\$ -	\$ -	\$ 4,440.00
PAYROLL TAX & INSURANCE (STR's Labor)	32.58%			\$ -
STR FEE ON OWN WORK	15.00%			\$ -
STR FEE ON SUBCONTRACTORS	10.00%			\$ 444.00
BOND	2.50%			\$ 122.10
INSURANCE	0.86%			\$ 43.06
TOTAL COST				\$ 5,049.16
QUALIFICATIONS & CLARIFICATIONS:				
<p>This change proposal becomes null & void after ten calendar days (10) and extends the contract completion date by 0 working days at \$ 1,058.40 dollars of cost for general conditions expenses per each calendar day. Work stoppage due to late acceptance of this change proposal voids this quotation and will increase the cost by the General Contractor's general conditions expenses which exceed (\$ 1,481.76) per work day. One Work day = 1.4 Calendar days.</p>				
STR CONSTRUCTORS, LTD.			Approved by:	
<i>TD Starfield</i>				
Project Manager	DATE:	<i>2/7/2018</i>	Date:	



CHANGE ORDER

PROJECT: WILCO Prison 508 South Rock Street Georgetown, TX 78626	CHANGE ORDER NUMBER: 4 BID # 17-2648 DATE: 2/7/2018 CONTRACT DATE: 10/27/2017
CONTRACTOR: Specialized Plumbing Technologies 226 Field End Street Sarasota, florida 34240	OWNER: STR Constructors, LTD 15500 Hwy 29 West Liberty Hill, TX 78642

Change Order includes the following:

1	(17) blowouts to be replaced		\$4,440.00
	Material	1,360.00	
	Labor	1,700.00	
	Per Diem & Travel	640.00	
	Overhead & Profit	740.00	

2

Total	\$4,440.00
-------	------------

Not valid until signed by Owner and Contractor.

The original Contract Sum
 Net change by Change Order #3
 The Contract Sum prior to this Change Order was
 The Contract Sum will be increased by this Change Order in the amount of
 The Contract Sum including this Change Order

The Contract Time will be increased by _____ days.

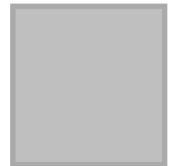

Specialized Plumbing Technologies	STR Constructors, LTD
CONTRACTOR	OWNER
226 Field End Street	1550 Hwy 29 West
ADDRESS	ADDRESS
Sarasota, FL 34240	Liberty Hill, TX 78642
By Bill Konkol	BY
DATE: 2/0719/18	DATE

STR CONSTRUCTORS, LTD.
CHANGE PROPOSAL

PROPOSAL ISSUED TO:		STR's PCO NO.: 17		
		Wilco Jail Kitchen & Plumbing Remodel 508 South Rock Street Georgetown, TX		
ATTENTION:		Dale Bulter Asst Director, Projects		
DESCRIPTION:				
Add for kitchen Floor Surface COLOR Upgrade - Premium BLUE				
Description	Subcontracts	Material	Labor	Total
STR Constructor's Direct Costs				\$ -
(see attached STR GC Breakdown)		\$ -	\$ -	\$ -
				\$ -
				\$ -
				\$ -
Subcontract Cost				\$ -
DLS Flooring Systems (Color Upgrade)	\$ 1,983.00			\$ 1,983.00
				\$ -
				\$ -
				\$ -
				\$ -
				\$ -
				\$ -
				\$ -
				\$ -
DIRECT COST	\$ 1,983.00	\$ -	\$ -	\$ 1,983.00
PAYROLL TAX & INSURANCE (STR's Labor)	32.58%			\$ -
STR FEE ON OWN WORK	15.00%			\$ -
STR FEE ON SUBCONTRACTORS	10.00%			\$ 198.30
BOND	2.50%			\$ 54.54
INSURANCE	0.86%			\$ 19.23
TOTAL COST				\$ 2,255.07
QUALIFICATIONS & CLARIFICATIONS:				
<p>This change proposal becomes null & void after ten calendar days (10) and extends the contract completion date by 0 working days at \$ 1,058.40 dollars of cost for general conditions expenses per each calendar day. Work stoppage due to late acceptance of this change proposal voids this quotation and will increase the cost by the General Contractor's general conditions expenses which exceed (\$ 1,481.76) per work day. One Work day = 1.4 Calendar days.</p>				
STR CONSTRUCTORS, LTD.			Approved by:	
<i>TD Starfield</i>				
Project Manager	DATE:	<i>2/8/2018</i>	Date:	

CHANGE ORDER REQUEST

Company: STR Constructors, LTD
Contact: Tom Stanfield
Location: Williamson County Jail Kitchen
DLS Job Number: DLS0180315-001
Date of Change: 02/08/18
Request Submitted By: Todd Zeiler

Scope Add

Add Urethane flooring and joint sealant to Premium Color Blue

Total cost of \$1,983

Please call if you have any questions. We look forward to being of service.

Change Order Approved By: _____

Title: _____

Date: _____



DLS Flooring Systems
Todd Zeiler
PO Box 560367
The Colony, TX 75056

February 5, 2018

Dear Todd,

Following our earlier conversation, I would like to confirm the following colors are premium colors for Polyurethane concrete:

Safety Yellow
Green
Blue
Custom colors

These colors are subject to additional pricing, lead time and batch sizes.

Standard colors are as follows and are subject to standard pricing:

Red
Dark Gray
Gray
Tan
Black

If you have any questions please let me know.

Sincerely,
Ann Delve

Williamson County Facilities - Job Cost Tracking Log

Project: Jail Kitchen Remodel P411

Change Order #: 3

Change Order No.	Court Agenda Date	Party of Initiation	Time Ext. (Days)	Cost of Work	Owner Contingency	Total Updated Contract Amount
Contract			180	\$ 1,781,645.00	\$ 250,000.00	\$ 2,031,645.00
1	12/12/2017	Architect	10	\$ 118,633.53	\$ (118,633.53)	\$ 2,031,645.00
2	2/20/2018		8	\$ 42,482.97	\$ (42,482.97)	\$ 2,031,645.00
3			2	\$ 49,389.05	\$ (49,389.05)	\$ 2,031,645.00
Total			200	\$ 1,992,150.55	\$ 39,494.45	

Commissioners Court - Regular Session

19.

Meeting Date: 02/27/2018

Jail Remodel Project P411 - Change Order 4

Submitted By: Gina Wrehsnig, Infrastructure

Department: Infrastructure

Division: Building Maintenance

Agenda Category: Consent

Information

Agenda Item

Discuss, consider and take appropriate action on accepting and approving a report on the Jail Kitchen and Plumbing Remodel Project; Change Order # 4 in the amount of \$37,632.70 for additional HVAC and plumbing work associated with ASI # 3, scope deletion credit and Owner requested repairs and changes at kitchen doors and ceilings, which was executed by Dale Butler, Williamson County Facilities Project Manager, pursuant to the previous grant of authority under Section 262.031 of the Local Government Code. This change order is being funded out of the Owners Contingency.

Background

On August 15, 2017, the Williamson County Commissioners Court granted Dale Butler, Williamson County Facilities Project Manager, with general authority to approve change orders for the Agreement for Construction Services with STR Constructors, Ltd. in relation to the Williamson County Jail Kitchen and Plumbing Remodel Project for any increase in costs up to a total maximum amount of \$50,000.00 in accordance with Section 262.031 of the Local Government Code – Changes in Plans and Specifications. This report is being provided for purposes of notifying the court of such change order and to place it in the minutes of the Commissioners Court.

Fiscal Impact

From/To	Acct No.	Description	Amount
---------	----------	-------------	--------

Attachments

[Jail Change Order 4](#)

[Jail CO4 Funds](#)

Form Review

Inbox

County Judge Exec Asst.

Form Started By: Gina Wrehsnig

Final Approval Date: 02/22/2018

Reviewed By

Wendy Coco

Date

02/22/2018 08:28 AM

Started On: 02/22/2018 08:12 AM

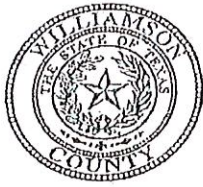

WILLIAMSON COUNTY, TEXAS

FACILITIES DEPARTMENT

3101 SE Inner Loop

Georgetown, TX 78626

512-943-1609

CHANGE ORDER

For Project: WILLIAMSON COUNTY JAIL KITCHEN & PLUMBING REMODEL

Date of Issuance: 2/12/2018

Change Order No: 4R1

Contractor: STR Constructors, LTD.

PID: _____

Project Engineer: Talex, Inc.

Explanation:

This change order is due to the following:

PCO-12 - CREDIT of the Deletion of the Wall Relocation between Mech & Elec room

PCO-14A - Add for Plumbing & Mech changes associated with ASI #3

PCO-15 - Add to Kitchen Ceiling Change per ASI 04

PCO-18 Replacment of 2ea HM Doors & Repair of 2ea HM Frames, per Owner Request

Description of Work:	Cost
See attached PCO #12	\$ (6,109.90)
See attached PCO #14A	\$ 15,530.78
See attached PCO #15	\$ 19,808.84
See attached PCO #18	\$ 8,402.98
Weather Days -	
Sub-Total CO #3	\$ 37,632.70

Additional Time	
KITCHEN AREA	OVERALL PROJECT
0 Days	0 Days
0 Days	0 Days
0 Days	0 Days
0 Days	0 Days
0 Days	0 Days
0 Days	0 Days
0 Days	0 Days
0 Days	0 Days
0 Days	0 Days
0 Days	0 Days
0 Days	0 Days
0 Days	0 Days

Please Refer to Attached Backup Documents:

Cost and Time Change Summary

Original Contract:

Previous Change Order(s):

Contract Prior to this CO:

Net Increase from this CO:

Revised Contract Total:

	Cost
Original Contract:	\$ 1,781,645.00
Previous Change Order(s):	\$ 210,505.55
Contract Prior to this CO:	\$ 1,992,150.55
Net Increase from this CO:	\$ 37,632.70
Revised Contract Total:	\$ 2,029,783.25

Additional Time	
KITCHEN AREA	OVERALL PROJECT
120 Days	180 Days
10 Days	10 20 Days
130 Days	190 Days
0 Days	0 Days
130 Days	190 200 Days

RECOMMENDED BY:

Gilbert Bolding
Contractor Signature*

Gilbert Bolding, Sr PM for
T. R. Kennedy, President
Contractor Name

T.R. Alexander
Engineer Signature

THOMAS R. ALEXANDER, P.E.
Oscar Villarreal, P.E.
Engineer Name

2/16/18
Signature Date

2/16/18
Signature Date

ACCEPTED BY:

Dale Bulter
Owner Signature

Dale Bulter, Asst Dir - Projects
Owners' Rep Name

2/20/18
Signature Date

*By Signing this change order the Contractor accepts the changes herein and agrees to perform the change(s) for the price and time indicated. The prices include all costs to perform the work.

No work shall be done until this change order is executed. No payment to the Contractor (or Consultant) shall be made for work included in this Change Order until Contractor's pay estimate is updated.

In case of conflict between construction documents and this change order, this change order shall govern.

Upon execution of this Change Order by all parties, the identified time and cost changes herein are made part of the contract documents.

STR CONSTRUCTORS, LTD.
CHANGE PROPOSAL

PROPOSAL ISSUED TO:		STR's PCO NO.: 12		
Wilco Jail Kitchen & Plumbing Remodel 508 South Rock Street Georgetown, TX				
ATTENTION:		Dale Bulter Asst Director, Projects		
DESCRIPTION:				
Credit to leave existing Wall between J1123 & J1124, and associated work				
Description	Subcontracts	Material	Labor	Total
STR Constructor's Direct Costs				
(see attached STR GC Breakdown)				
	\$	-	\$	-
				\$ -
				\$ -
				\$ -
				\$ -
				\$ -
Subcontract Cost				
Maynard Const - Demo	\$ (485.00)			\$ (485.00)
Doyle Elec	\$ (2,595.00)			\$ (2,595.00)
CD Lonestar - masonry	\$ (2,690.00)			\$ (2,690.00)
Casto Lopez - concrete	\$ (339.90)			\$ (339.90)
				\$ -
				\$ -
				\$ -
				\$ -
				\$ -
				\$ -
DIRECT COST	\$ (6,109.90)	\$ -	\$ -	\$ (6,109.90)
PAYROLL TAX & INSURANCE (STR's Labor)	32.58%			\$ -
STR FEE ON OWN WORK	15.00%			\$ -
STR FEE ON SUBCONTRACTORS	10.00%			\$ -
BOND	2.50%			\$ -
INSURANCE	0.86%			\$ -
TOTAL COST				\$ (6,109.90)
QUALIFICATIONS & CLARIFICATIONS:				
<p>This change proposal becomes null & void after ten calendar days (10) and extends the contract completion date by 0 working days at \$ 1,058.40 dollars of cost for general conditions expenses per each calendar day. Work stoppage due to late acceptance of this change proposal voids this quotation and will increase the cost by the General Contractor's general conditions expenses which exceed (\$ 1,481.76) per work day. One Work day = 1.4 Calendar days.</p>				
STR CONSTRUCTORS, LTD.			Approved by:	
<i>TD Starfield</i>				
Project Manager	DATE:	<i>2/7/2018</i>	Date:	

Maynard Construction



Services

CREDIT

To: STR Construction Ltd.
Attn: Tom Stanfield
str@strconstructors.com
512-515-0254 Ext. 223

Date: January 26, 2018

Williamson County Jail Kitchen Remodel

Description of Work Credit:

Removal of the Wall & Slab between Mech Rm J1124 & Elec Rm J1123.

EXCLUSIONS:

	Subtotal:	\$485
	20% Mark Up:	
	Change Order Amount:	\$485

Direct all inquiries to:

Kenneth Maynard
(512) 924-5279

ken@maynardcs.com

Accepted by:

Date: _____

Maynard Construction Services
P.O. Box 127
Briggs, Texas 78608
512-887-DEMO
www.maynardcs.com

Thank You For Your Business!

Item#	Description	Qty	Price	Price	Ext Price	Labor	Labor	Ext Labor
1122	Demo Panel Boards	2.00	0.00	E	0.00	1.50	E	3.00
1445	Demo 75 KVA Transformer	1.00	0.00	E	0.00	5.00	E	5.00
1545	Reconnection of existing circuits	1.00	0.00	E	200.00	18.00	E	18.00
1844	Relocate 75 KVA Transformer	1.00	250.00	E	250.00	12.00	E	12.00
2339	Install Panel Boards	2.00	50.00	E	50.00	4.50	E	9.00
TOTALS					500.00			47.00

<u>Change Order Summary</u>	
Material Total	-\$500.00
Material Subtotal	-\$500.00
Electrician Hours	-23.5
Electrician per Hour Including Burden	\$33.12
Superintendent Hours	-23.5
Superintendent per Hour Including Burden	\$56.05
Labor Subtotal	-\$2,095.50
<i>Consumables (6% of material)</i>	<i>\$0.00</i>
<i>Project Management (5% of labor)</i>	<i>\$0.00</i>
<i>Safety (\$0.50 per labor hour)</i>	<i>\$0.00</i>
<i>Equipment</i>	<i>\$0.00</i>
<i>Subcontractors</i>	<i>\$0.00</i>
Direct Costs Subtotals	\$0.00
Total Costs Subtotal	-\$2,595.50
Overhead and Profit (15%)	\$0.00
CHANGE ORDER TOTAL	-\$2,595

Doyle Electric, LLC

1108 S Lakeside Dr
Burnet, Texas 78611
Phone: 512-743-5534

Request for Change Order

1/29/18

TO:

STR Constructors, LTD
1550 HWY 29 West
Liberty Hill TX 78642

JOB:

Project: Williamson County Jail Remodel
306 W. 4th St. Georgetown TX 78628
Change Order Number: 4

CHANGE ORDER INFORMATION: Wall removal between room J1123 and J1124

WORK Description; Relocating electrical due to wall being relocated

The total amount of this Change Order is: - \$2,595.00

Sincerely,

Jeremy Denniss
Doyle Electric, LLC
512-745-0228



CASTO LOPEZ CONCRETE LLC

To: Estimating Department

Subject: Williamson County Jail ~~Freezer Credit~~ Mech / Elec Slab Credit

Reference: Cast-In-Place Concrete

Sir,

Casto Lopez Concrete will provide manpower, equipment, materials, and labor to perform the scope below.

Building Concrete Credit

Concrete Credit

Labor

- Pour 26 SF- 5 Man Hours
- Tie Rebar: 1 Man Hour

Materials

- Concrete: 1 CY
- Rebar: 50 Lbs

Subtotal: \$309.00
Overhead and Profit: \$30.90
Total Credit: \$339.90

A job Information sheet will be required for the project is awarded. Please contact Venancio Lopez if you have any questions at 512-351-6316.

Sincerely,

Venancio Lopez
CASTO LOPEZ CONCRETE LLC

512-523-8295

1955 FM 2001 Suite 200
Buda Texas 78610
clconcreteatx@gmail.com

February 7, 2018

HUB #491371/1472749211900
CITY OF AUSTIN VENDOR #V00000919820
CITY OF AUSTIN MBE CERTIFICATION
CITY OF AUSTIN RIGHT-OF-WAY CONTRACTOR #2014-043835 LC
DUNS AND BRADSTREET #023325192

Tom Stanfield

From: Tom Stanfield <toms@strconstructors.com>
Sent: Wednesday, February 07, 2018 11:15 AM
To: 'Tom Stanfield'
Subject: FW: Williamson County Jail Kitchen and Plumbing remodel

From: CD Lone Star Estimating Dept. [<mailto:estimating@cdlonestar.com>]
Sent: Friday, February 02, 2018 12:18 PM
To: Tom Stanfield
Cc: Chris Toth; CD Lone Star Estimating Dept.
Subject: RE: Williamson County Jail Kitchen and Plumbing remodel

Tom,

-Delete "new 8" CMU wall - <\$ 2,690.00>

Note: remediation of existing Masonry (brick veneer & CMU), at duct penetrations, remains.

If questions, call (512 848-5778) or email.

Chris Toth
CD Lone Star, Inc.

STR CONSTRUCTORS, LTD.
CHANGE PROPOSAL

PROPOSAL ISSUED TO:		STR's PCO NO.: 14A		
		Wilco Jail Kitchen & Plumbing Remodel 508 South Rock Street Georgetown, TX		
ATTENTION:		Dale Bulter Asst Director, Projects		
DESCRIPTION:				
Add for Mech & Plumbing Changes per ASI 03 Revised Kitchen Equipment. Elec impacts priced separately, along with associated time extension				
Description	Subcontracts	Material	Labor	Total
STR Constructor's Direct Costs				
(see attached STR GC Breakdown)		\$ -	\$ -	\$ -
(Chip down, cut, & grout abandon floor elec)		\$ 50.00	\$ 560.00	\$ 610.00
				\$ -
				\$ -
Subcontract Cost				
	Gemini Mech	\$ 12,207.00		\$ 12,207.00
	Capital Plumbing	\$ 621.60		\$ 621.60
				\$ -
				\$ -
				\$ -
				\$ -
				\$ -
				\$ -
				\$ -
				\$ -
DIRECT COST	\$ 12,828.60	\$ 50.00	\$ 560.00	\$ 13,438.60
PAYROLL TAX & INSURANCE (STR's Labor)	32.58%			\$ 182.45
STR FEE ON OWN WORK	15.00%			\$ 118.87
STR FEE ON SUBCONTRACTORS	10.00%			\$ 1,282.86
BOND	2.50%			\$ 375.57
INSURANCE	0.86%			\$ 132.43
TOTAL COST				\$ 15,530.78
QUALIFICATIONS & CLARIFICATIONS:				
<p>This change proposal becomes null & void after ten calendar days (10) and extends the contract completion date by 0 working days at \$ 1,058.40 dollars of cost for general conditions expenses per each calendar day. Work stoppage due to late acceptance of this change proposal voids this quotation and will increase the cost by the General Contractor's general conditions expenses which exceed (\$ 1,481.76) per work day. One Work day = 1.4 Calendar days.</p>				
STR CONSTRUCTORS, LTD.			Approved by:	
<i>TD Starfield</i>				
Project Manager	DATE:	<i>2/16/2018</i>	Date:	

ASI #3 Change Proposal



18 Indian Meadow Round Rock, Texas 78664 (512)244-3436 office (512) 244-3498 fax
TACLB00028659E

General Contractor: STR
Attn: Tom Stanfield

February 8, 2018

Re: Wilco Jail Kitchen Additional Fans and Duct – ASI #3

Per revised sheets: M101, ME101, M601

Scope of Work:

1. Furnish and install (1) new cook direct drive dishwasher exhaust fan and curb (DEF-1)
2. Furnish and install (1) new bakery belt driven cook exhaust fan and curb (BEF-1)
3. Hvac demolition as required to accommodate new work per ASI #3
4. Adapt new stainless steel dishwasher exhaust ductwork (welded water tight)
5. DDC controls to monitor new DEF and BEF per Oscar
6. Certified test and balance
7. Hoisting
8. Start-up of new equipment.
9. Labor and supervision.
10. Prevailing wages / certified payroll

Exclusions:

1. All cutting, coring, x-raying, patching or framing of walls, floors and roof for ductwork and piping penetrations.
2. Electrical conduit, disconnects, motor or mag starters, wiring or hook-up.
3. Roofing work of any kind
4. Sales tax.
5. Gemini Mechanical assumes no responsibility for the operations or performance of any existing equipment or systems regardless of whether our contractual scope of work relocates, modifies or connects to these existing devices or systems.

Materials:	\$9,294.00
Labor:	\$1,321.00
Sub Total:	\$10,615.00
15% O/M:	\$1,592.00
Total:	\$12,207.00

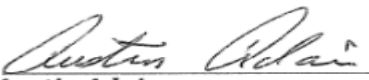
Austin Adair

Office Phone: (512) 244-3436 #213 / Mobile: (512) 999-8338
Email: ADAIR@GEMINIMECH.COM

Capitol Plumbing and Repair

CPR - "We bring your plumbing back to life"

401 CR 266, Georgetown TX 78628

Ph: 512-577-1262

Fax: 512-778-5554

e-mail: keith_cpr@yahoo.com

Change Order #2

To: STR Construction

Attn: Tom Stanfield

Project: Williamson County Jail

Description: Cap off waste and water lines for (2) hand sinks.

Materials: \$68.00

4 – ½" copper caps

2 – 1 ½" brass plugs

1 – Solder, Flux, Sand, and Gas

Labor: \$450.00

Plumber 5 hours @ \$90/hr

20% Overhead and Profit: \$103.90

Total: \$621.60

STR CONSTRUCTORS, LTD.
CHANGE PROPOSAL

PROPOSAL ISSUED TO:		STR's PCO NO.: 15		
Wilco Jail Kitchen & Plumbing Remodel				
508 South Rock Street				
Georgetown, TX				
ATTENTION:		Dale Bulter		
		Asst Director, Projects		
DESCRIPTION:				
Ceiling change to Suspended Acoustical in Kitchen Area, per ASI 04				
Description	Subcontracts	Material	Labor	Total
STR Constructor's Direct Costs				\$ -
(see attached STR GC Breakdown)				\$ -
				\$ -
				\$ -
Subcontract Cost				\$ -
American Drywall				\$ -
(Credit of Drywall Ceiling) \$ (16,770.00)				\$ (16,770.00)
(Add For Sup Ceiling) \$ 37,430.00				\$ 37,430.00
				\$ -
Slater Painting				\$ -
(Tape, Float, Paint CREDIT) \$ (3,241.00)				\$ (3,241.00)
				\$ -
				\$ -
				\$ -
				\$ -
DIRECT COST				\$ 17,419.00
PAYROLL TAX & INSURANCE (STR's Labor) 32.58%				\$ -
STR FEE ON OWN WORK 15.00%				\$ -
STR FEE ON SUBCONTRACTORS 10.00%				\$ 1,741.90
BOND 2.50%				\$ 479.03
INSURANCE 0.86%				\$ 168.91
TOTAL COST				\$ 19,808.84
QUALIFICATIONS & CLARIFICATIONS:				
<p>This change proposal becomes null & void after ten calendar days (10) and extends the contract completion date by 0 working days at \$ 1,058.40 dollars of cost for general conditions expenses per each calendar day. Work stoppage due to late acceptance of this change proposal voids this quotation and will increase the cost by the General Contractor's general conditions expenses which exceed (\$ 1,481.76) per work day. One Work day = 1.4 Calendar days.</p>				
STR CONSTRUCTORS, LTD.		Approved by:		
<i>TD Starfield</i>				
Project Manager	DATE:		Date:	
	<i>2/7/2018</i>			

American Drywall Systems, Inc.

11821-A Buckner Road • Austin, Texas 78726
(512) 250-1666 Office • (512) 918-0770 Facsimile

CHANGE ORDER

Project: Williamson County Jail
Location: Georgetown, Texas
Contractor: STR Constructors
Attention: Tom Stanfield
Address: 15500 Hwy. 29 West
Liberty Hill, Texas

Date: 2-1-18
ASI No: 4
Facsimile:
Deliver:
E-Mail x

Item	Description	Cost
	Price to install 2x4 Aluminum Cap Grid and 2 x 4 Ceramaguard Ceiling Tile in the Kitchen In leu of the drywall ceiling. This price also includes the acoustical drop in the Dry Storage Room. Material: \$22,485.00 Labor: \$14,945.00	
	Credit for drywall ceiling in Kitchen and 2 x 4 acoustical grid in Rooms Dry Storage and Office. Material: <\$6,800.00> Labor: <\$9,970.00>	
	Total:	\$20,659.00

ATTENTION: THIS CHANGE ORDER MUST BE SIGNED AND RETURNED TO OUR OFFICE BEFORE ANY WORK RELATED TO IT WILL PROCEED:

AMERICAN DRYWALL SYSTEMS, INC.

We hereby agree to furnish all labor and materials for the additional work described above in accordance with the provisions of the original contract unless otherwise stipulated.

Signed:  Date: 2-1-18

Accepted by: _____ Date: _____

Slater Painting

2/7/2018

Tom Stanfield
STR Constructors, Inc.
Liberty Hill, TX 78642

Fax: 512-515-0534

Re: Williamson County Jail

Dear Tom:

We have reviewed proposal request to deduct tape, float and painting of the gyp ceiling in Kitchen and the deduct is - \$ 3,241.00.

Attached for your review is our cost breakdown. Please advise if this change proposal is accepted.

Sincerely,

A handwritten signature in black ink, appearing to read 'Brad Jackson', with a long horizontal line extending to the right.

Brad Jackson
Project Manager

ESTIMATE RECAP

PROJECT:
 BID DATE:

WILLIAMSON COUNTY JAIL
 2/7/18

DESCRIPTION	QNTY	UNIT	LABOR		\$18.00	MATERIALS PROJECT		TOTALS
			M.H.	UNIT	MAN HOUR	TOTAL	UNIT	
T/F CEILINGS	-3700	SF	0.017	-62.90	-1132.20	0.040	-148.00	-1280
PRIME CEILING	-3748	SF	0.006	-22.49	-404.78	0.040	-149.92	-555
PAINT CEILING	-3748	SF	0.006	-22.49	-404.78	0.060	-224.88	-630
SUBTOTAL				-107.88	-1941.77		-522.80	-2465
BURDEN	40.00 %				-776.71			-777
SALES TAX	0.00 %						0.00	0
SUBTOTAL					-2718.48		-522.80	-3241
						O & P	0.00	0
						TOTAL		-3241

STR CONSTRUCTORS, LTD.
CHANGE PROPOSAL

PROPOSAL ISSUED TO:		STR's PCO NO.: 18							
		Wilco Jail Kitchen & Plumbing Remodel 508 South Rock Street Georgetown, TX							
ATTENTION:		Dale Bulter Asst Director, Projects							
DESCRIPTION:									
Remove & Replace 2ea existing Hollow Metal Doors with In-place Frame Hinge Repairs, per Owners' Request									
<table style="width: 100%; border-collapse: collapse;"> <thead> <tr> <th style="width: 45%;">Description</th> <th style="width: 15%;">Subcontracts</th> <th style="width: 15%;">Material</th> <th style="width: 15%;">Labor</th> <th style="width: 10%;">Total</th> </tr> </thead> </table>					Description	Subcontracts	Material	Labor	Total
Description	Subcontracts	Material	Labor	Total					
STR Constructor's Direct Costs									
		\$ -		\$ -					
Remove & salvage existing Dr Hrdwr		\$ -	\$ 560.00	\$ 560.00					
				\$ -					
Subcontract Cost									
Hull Supply - Frame Repairs & door Replace	\$ 6,066.00			\$ 6,066.00					
Slater Paint - Paint new doors	\$547.00			\$ 547.00					
				\$ -					
				\$ -					
				\$ -					
				\$ -					
				\$ -					
				\$ -					
				\$ -					
				\$ -					
				\$ -					
				\$ -					
DIRECT COST	\$ 6,613.00	\$ -	\$ 560.00	\$ 7,173.00					
PAYROLL TAX & INSURANCE (STR's Labor)	32.58%			\$ 182.45					
STR FEE ON OWN WORK	15.00%			\$ 111.37					
STR FEE ON SUBCONTRACTORS	10.00%			\$ 661.30					
BOND	2.50%			\$ 203.21					
INSURANCE	0.86%			\$ 71.65					
TOTAL COST				\$ 8,402.98					
QUALIFICATIONS & CLARIFICATIONS:									
<i>NOTE: The existing door hardware will be removed and reinstalled</i>									
This change proposal becomes null & void after ten calendar days (10) and extends the contract completion date by 0 working days at \$ 1,058.40 dollars of cost for general conditions expenses per each calendar day. Work stoppage due to late acceptance of this change proposal voids this quotation and will increase the cost by the General Contractor's general conditions expenses which exceed (\$ 1,481.76) per work day. One Work day = 1.4 Calendar days.									
STR CONSTRUCTORS, LTD.			Approved by:						
<i>TD Starfield</i>									
Project Manager		DATE:	Date:						
		<i>2/16/2018</i>							



■ SUPPLY ■ SERVICES ■ ACCESS CONTROLS
■ COMMERCIAL DOORS, FRAMES, & HARDWARE

www.hullsupply.com Security License #B15803

5117 East Cesar Chavez PH: 512-385-1262
Austin, TX 78702 Fax: 512-389-0031

MARK LONGORIA
marklongoria@hullservices.com
Ph: 512-439-2779

Quote



Sales Order NO:0203888
Order Date: 2/8/2018
Ship Date: **2/12/2018**
Job NO:

**S
O
L
D
TO:**

0005133
STR CONSTRUCTORS, LTD.
15500 HWY 29 WEST
LIBERTY HILL, TX 78642

ContactName: JAMES WEEKS
ContactPh: 512 - 308 - 8534
LONEwolf123@live.com

**S
H
I
P
TO:**

WILL CO JAIL - KITCHEN AREA
505 ROCK STREET
TRAILER : 650 ROCK STREET
GEORGETOWN, TX 78626

HOLLOW METAL DOOR

Customer PO	Ship Via	FOB	TERMS	Written By :				
QUOTE	SVC 8 INSTALL		Net 30 days	MARK LONGORIA				
Line NO	Ship UM Qty	Qty Picked	Qt y	ITEM NUMBER	ITEM DESCRIPTION	BIN	UnitPrice	ExtAmt

REPLACING EXISTING HOLLOW METAL DOOR.

4	1 EA			40708MULTI	DR 4070 18G MULTIFIT	Bin: HMD-1C-09	1,369.00	1,369.00
5	1 EA			SL57CLHD83	SEL SL57 FS HD GEAR HGE CLR 7'	Bin: CG-11C-C16	150.00	150.00
6	3 EA			HMFSCREWHGFILL	HMF INSTALL HINGE FILLER 4-1/2" (EACH)	Bin:	5.00	15.00
7	1 EA			L-FRA100-1212	NGP LFRA100 WB 12x12 LITE KIT	Bin: LK-1-A4	30.00	30.00
8	1 EA			WIRELITE-NT-11X	11" X 11" X 1/4" WIRELITE NT GLASS90 MIN	Bin: GL1-A-01	80.00	80.00
9	1 EA			BUTYLTAPE	TREMCO 440 BUTYL TAPE 25' ROLL 1/8" X 3/8"	Bin: WC.OFFICE	14.00	14.00
10	1 EA			4040XPAL	LCN 4040XP CLOSER RW/PA 689	Bin: CG-03A-C03	330.00	330.00

USING EXISTING HARDWARE.

TO BE FEILD PAINTED BY OTHERS.

15				/095	FIELD VERIFICATION	Bin:		95.00
16				/LABOR.REMODEL	LABOR - REMODEL	Bin:		950.00

HMD STF KEYSHOP PURCHASING
WDR ALF INSTALL SHIPPING
HMF CAGE TAGGING SERVER



SUPPLY SERVICES ACCESS CONTROLS
COMMERCIAL DOORS, FRAMES, & HARDWARE

www.hullsupply.com Security License #B15803

5117 East Cesar Chavez PH: 512-385-1262
Austin, TX 78702 Fax: 512-389-0031

MARK LONGORIA
marklongoria@hullservices.com
Ph: 512-439-2779

Quote

Sales Order NO:0203888
Order Date: 2/8/2018
Ship Date: **2/12/2018**
Job NO:

**S
O
L
D
TO:**

0005133
STR CONSTRUCTORS, LTD.
15500 HWY 29 WEST
LIBERTY HILL, TX 78642

ContactName: JAMES WEEKS
ContactPh: 512 - 308 - 8534
LONEwolf123@live.com

**S
H
I
P
TO:**

WILL CO JAIL - KITCHEN AREA
505 ROCK STREET
TRAILER : 650 ROCK STREET
GEORGETOWN, TX 78626

HOLLOW METAL DOOR

Customer PO	Ship Via	FOB	TERMS	Written By :
-------------	----------	-----	-------	--------------

QUOTE SVC 8 INSTALL Net 30 days MARK LONGORIA

Line NO	Ship UM Qty	Picked	Qt y	ITEM NUMBER	ITEM DESCRIPTION	BIN	UnitPrice	ExtAmt
---------	-------------	--------	------	-------------	------------------	-----	-----------	--------

Unless Specifically Noted Otherwise:

- (1) MATERIAL BID F.O.B. POINT OF SHIPMENT WITH FREIGHT BEING AN ADDITIONAL CHARGE AND PAID BY PURCHASER.
- (2) TAXES ARE INCLUDED UNLESS NOTED OTHERWISE.
- (3) NO INSTALLATION IS INCLUDED UNLESS NOTED OTHERWISE.
- (4) THIS PROPOSAL MUST BE ACCEPTED IN WRITING WITHIN 30 DAYS FROM THE DATE OF PROPOSAL ABOVE.
- (5) PRICES SUBJECT TO CHANGE AFTER 30 DAYS FROM DATE OF PROPOSAL.
- (6) THIS AGREEMENT IS CONTINGENT UPON STRIKES, WAR, TERRORIST ACTIVITIES, ACTS OF GOD, PRODUCT AVAILABILITY AND/OR OTHER DELAYS UNAVOIDABLE OR BEYOND OUR CONTROL.
- (7) ALL ACCOUNTS DUE AND PAYABLE IN AUSTIN, TRAVIS COUNTY, TEXAS, WHERE VENUE SHALL LIE.
- (8) PRICE & TERMS WITH APPROVED CREDIT; TERMS NET 30 DAYS-UNPAID BALANCE ON PAST DUE ACCOUNTS SUBJECT TO 18% ANNUAL SIMPLE INTEREST PER MONTH.
- (9) NO MATERIALS WILL BE SHIPPED UNLESS WE HAVE BOTH A SIGNED PROPOSAL AND A PURCHASE ORDER PROPERLY EXECUTED.
- (10) BID IS PER PLANS & SPECIFICATIONS-DEVIATIONS TO THE PLANS AND SPECS ARE ENUMERATED ABOVE.
- (11) HULL SUPPLY CO., INC. WILL NOT ENROLL IN OR REBATE MONIES FOR ANY CCIP OR OCIP INSURANCE PROGRAMS.

HULL SUPPLY REQUIRES EITHER VALID CREDIT CARD INFO ON FILE OR A CHECK ONSITE PRIOR TO DISPATCHING SERVICE TECHNICIANS FOR CUSTOMERS WITHOUT AN ACCOUNT.
WORK WILL BE DELAYED IF PAYMENT INFO CANNOT BE CONFIRMED OR OBTAINED.
CREDIT CARD PAYMENT WILL BE PROCESSED UPON COMPLETION OF THE PROJECT.

HMD STF KEYSHOP PURCHASING
WDR ALF INSTALL SHIPPING
HMF CAGE TAGGING SERVER



■ SUPPLY ■ SERVICES ■ ACCESS CONTROLS
■ COMMERCIAL DOORS, FRAMES, & HARDWARE

www.hullsupply.com Security License #B15803

5117 East Cesar Chavez PH: 512-385-1262
Austin, TX 78702 Fax: 512-389-0031

MARK LONGORIA
marklongoria@hullservices.com
Ph: 512-439-2779

Quote

Sales Order NO:0203888
Order Date: 2/8/2018
Ship Date: **2/12/2018**
Job NO:

S
O
L
D
TO:

0005133
STR CONSTRUCTORS, LTD.
15500 HWY 29 WEST
LIBERTY HILL, TX 78642

ContactName: JAMES WEEKS
ContactPh: 512 - 308 - 8534
LONEwolf123@live.com

S
H
I
P
TO:

WILL CO JAIL - KITCHEN AREA
505 ROCK STREET
TRAILER : 650 ROCK STREET
GEORGETOWN, TX 78626

HOLLOW METAL DOOR

Customer PO	Ship Via	FOB	TERMS	Written By :				
QUOTE	SVC 8 INSTALL		Net 30 days	MARK LONGORIA				
Line NO	Ship UM Qty	Qty Picked	Qt y	ITEM NUMBER	ITEM DESCRIPTION	BIN	UnitPrice	ExtAmt

Note: The Quoted price below is for ONLY ONE DOOR
therefore Total Quote is \$3,033 per each X 2ea = \$6,066.00

Note: Check shipments thoroughly. We are not responsible for shipment after delivery. Your signature here means you acknowledge receipt of material on this page and previous page(s). Keep your receipt for verification of such.

Received by _____ Date: _____

Print Name: _____

RE-STOCKING FEE 25% *SPECIAL ORDERED ITEM NOT RETURNABLE

HMD STF KEYSHOP PURCHASING
WDR ALF INSTALL SHIPPING
HMF CAGE TAGGING SERVER

Hull Supply dba: Hull Services

Net Order:	3,033.00
Less Discount:	0.00
Freight	0.00
Sales Tax:	250.22
Order Total:	3,283.22
Less Deposit:	0.00
Order Balance:	3,283.22

Page 3 of 3
Printed: 2/13/2018 9:13:28AM
SVC QUOTE\SO_SalesOrder1.rpt

Slater Painting

2/13/2018

Tom Stanfield
STR Constructors, Inc.
Liberty Hill, TX 78642

Fax: 512-515-0534

Re:

Dear Tom:

We have reviewed proposal request to paint 2 new doors and frames and the cost for this work is an add of \$ 547.00.

Attached for your review is our cost breakdown. Please advise if this change proposal is accepted.

Sincerely,



Brad Jackson
Project Manager

ESTIMATE RECAP

DOORS & FRAMES

PROJECT:

WILLIAMSON COUNTY JAIL

BID DATE:

2/7/18

DESCRIPTION	QNTY	UNIT	LABOR		\$18.00	MATERIALS PROJECT		
			M.H.UNIT	MAN HOUR	TOTAL	UNIT	TOTAL	TOTALS
PAIN T HM DOOR	2	EA	2.500	5.00	90.00	15.000	30.00	120
PAIN T HM DOORFRAME	2	EA	2.000	4.00	72.00	15.000	30.00	102
PROTECTION & CLEAN UP	1	LS	4.000	4.00	72.00	50.000	50.00	122
SUBTOTAL				13.00	234.00		110.00	344
BURDEN	40.00 %				93.60			94
SALES TAX	0.00 %						0.00	0
SUBTOTAL					327.60		110.00	438
						O & P	0.25	109
						TOTAL		547

Williamson County Facilities - Job Cost Tracking Log

Project: Jail Kitchen Remodel P411

Change Order #: 3

Change Order No.	Court Agenda Date	Party of Initiation	Time Ext. (Days)	Cost of Work	Owner Contingency	Total Updated Contract Amount
Contract			180	\$ 1,781,645.00	\$ 250,000.00	\$ 2,031,645.00
1	12/12/2017	Architect	10	\$ 118,633.53	\$ (118,633.53)	\$ 2,031,645.00
2	2/20/2018		8	\$ 42,482.97	\$ (42,482.97)	\$ 2,031,645.00
3			2	\$ 49,389.05	\$ (49,389.05)	\$ 2,031,645.00
4			0	\$ 37,632.70	\$ (37,632.70)	\$ 2,031,645.00
Total			200	\$ 2,029,783.25	\$ 1,861.75	

Commissioners Court - Regular Session

20.

Meeting Date: 02/27/2018

Discuss consider and take appropriate action on approval of the preliminary plat for the Ranches at Salado Brook subdivision - Pct 3

Submitted For: Terron Evertson

Submitted By: Adam Boatright, Infrastructure

Department: Infrastructure

Division: Road & Bridge

Agenda Category: Consent

Information

Agenda Item

Discuss, consider, and take appropriate action on approval of the preliminary plat for the Ranches at Salado Brook subdivision - Pct 3.

Background

This proposed subdivision consists of 23 lots and no new public roads.

Fiscal Impact

From/To	Acct No.	Description	Amount
---------	----------	-------------	--------

Attachments

Preliminary Plat - Ranches at Salado Brook

Form Review

Inbox

County Judge Exec Asst.
Form Started By: Adam Boatright
Final Approval Date: 02/22/2018

Reviewed By

Wendy Coco

Date

02/22/2018 11:32 AM
Started On: 02/22/2018 11:17 AM

Preliminary Plat of The Ranches at Salado Brook

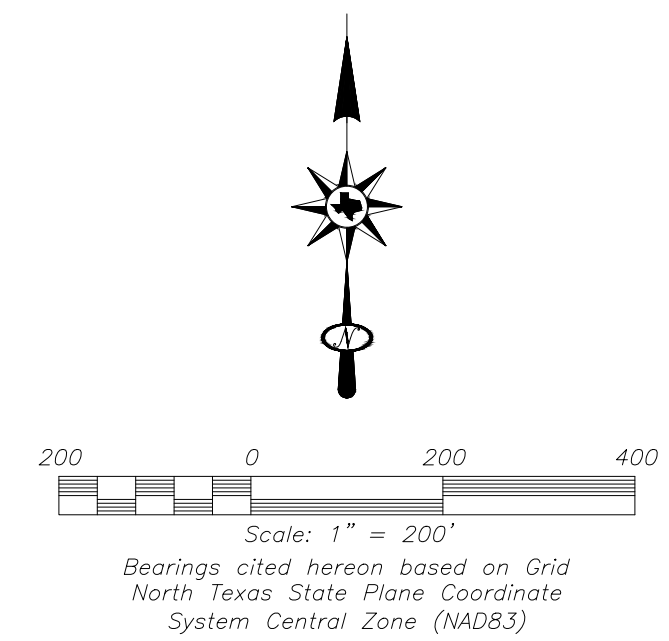
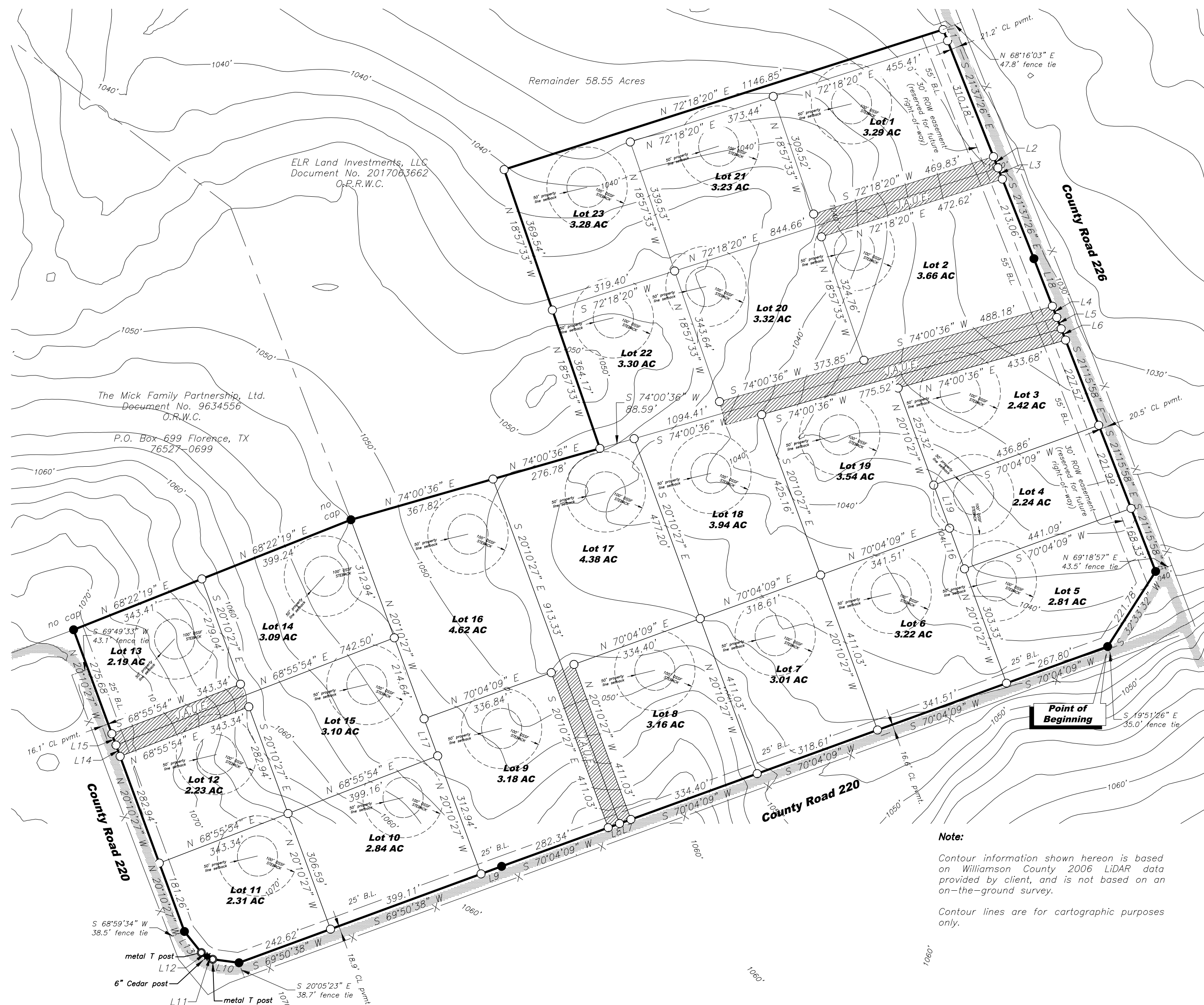

Date: November 27, 2017

- No lot in this subdivision is encroached by any special flood hazard areas inundated by 100 year flood as identified by the U.S. Federal Emergency Management Agency boundary map, (flood insurance rate map), community panel no. 48491C0100E, effective date September 26, 2008 for Williamson County, Texas. No structure or land on this plat shall hereafter be located or altered without first submitting a certificate of compliance to the Williamson County flood plain administrator.
- Lots 14-23 may not be further subdivided.

Line Table		
Line #	Bearing	Distance
L1	S 21°37'26" E	30.07'
L2	S 21°37'26" E	30.07'
L3	S 21°37'26" E	30.07'
L4	S 21°15'58" E	30.13'
L5	S 21°15'58" E	30.13'
L6	S 21°15'58" E	30.13'
L7	S 70°04'09" W	30.00'
L8	S 70°04'09" W	30.00'
L9	S 69°50'38" W	54.50'
L10	N 82°27'41" W	66.01'
L11	N 63°29'11" W	15.68'
L12	N 56°09'03" W	17.32'
L13	N 38°38'54" W	67.23'
L14	N 20°10'27" W	30.00'
L15	N 20°10'27" W	30.00'
L16	N 20°10'27" W	107.70'
L17	N 20°10'27" W	98.30'
L18	S 21°15'58" E	126.88'
L19	N 20°10'27" W	114.23'

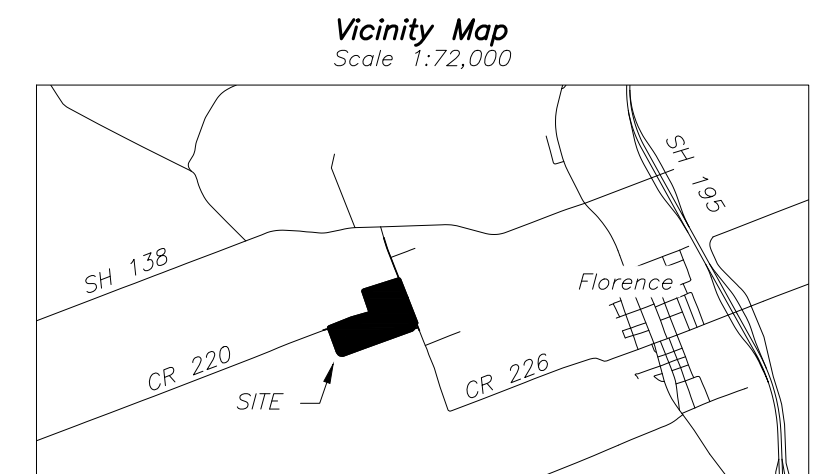

Note:
Contour information shown hereon is based on Williamson County 2006 LiDAR data provided by client, and is not based on an on-the-ground survey.
Contour lines are for cartographic purposes only.

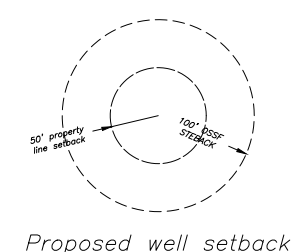

- 1/2 inch iron pin with yellow cap inscribed "WALKER 5283" found
- 1/2 inch iron pin with yellow cap inscribed "WALKER 5283" set
- X- wire fence
- O.P.R.W.C. Official Public Records Williamson County
- O.R.W.C. Official Records Williamson County
- J.A.U.E. Joint Access & Utility Easement (hatched areas)

Preliminary, this document shall not be recorded for any purpose and shall not be used or viewed or relied upon as a final survey document. This document is a "Working Sketch" to show project progress.

Charles G. Walker, RPLS #5283
Release Date December 13, 2017

Sheet 1 of 2

WALKER
TEXAS SURVEYORS
P.O. Box 324
Cedar Park, Texas 78630-0324
Phone (512) 259-3361
TBPLS Firm #10103800
Job #473003

Preliminary Plat of The Ranches At Salado Brook

STATE OF TEXAS §
 § KNOW ALL MEN BY THESE PRESENTS;
COUNTY OF WILLIAMSON §

I, Edwin Roark, manager for ELR Land Investments LLC, owner of the certain tract of land shown hereon and described in a deed recorded in Document No. 2017063662 of the Official Public Records of Williamson County, Texas, do hereby subdivide, said tract as shown hereon, and do hereby consent to all plat note requirements shown hereon, and do hereby forever dedicate to the public the roads, alleys, rights-of-way, easements and public places shown hereon for such public purposes as Williamson County may deem appropriate, and do hereby state that all public roadways and easements as shown on this plat are free of liens. This subdivision is to be known as **The Ranches At Salado Brook**.

TO CERTIFY WHICH, WITNESS by my hand this _____ day of _____, 20____.

Edwin Roark
ELR Land Investments, LLC
3910 Sequoia Trail West
Georgetown, Texas 78628

STATE OF TEXAS §
 § KNOW ALL MEN BY THESE PRESENTS;
COUNTY OF WILLIAMSON §

Before me, the undersigned, a notary public in and for said county and state, on this day personally appeared Edwin Roark, known to me to be the person whose name is subscribed to the foregoing instrument. Given under my hand and seal of office on this the _____ day of _____, 20____.

NOTARY PUBLIC in and for the State of Texas

STATE OF TEXAS §
 § KNOW ALL MEN BY THESE PRESENTS;
COUNTY OF WILLIAMSON §

I, _____, Lien Holder of the certain tract of land shown hereon and described in a deed recorded in Document No. 2017063662 of the Official Public Records of Williamson County, Texas, do hereby subdivide, said tract as shown hereon, and do hereby consent to all plat note requirements shown hereon, and do hereby forever dedicate to the public the roads, alleys, rights-of-way, easements and public places shown hereon for such public purposes as Williamson County may deem appropriate, and do hereby state that all public roadways and easements as shown on this plat are free of liens. This subdivision is to be known as **The Ranches at Salado Brook**.

TO CERTIFY WHICH, WITNESS by my hand this _____ day of _____, 20____.

Extraco Banks, N.A.

STATE OF TEXAS §
 § KNOW ALL MEN BY THESE PRESENTS;
COUNTY OF WILLIAMSON §

Before me, the undersigned, a notary public in and for said county and state, on this day personally appeared _____, known to me to be the person whose name is subscribed to the foregoing instrument. Given under my hand and seal of office on this the _____ day of _____, 20____.

NOTARY PUBLIC in and for the State of Texas

Surveyor's Certification

I, Charles G. Walker, Registered Professional Land Surveyor in the State of Texas, do hereby certify that this plat is true and correctly made from an actual survey made on the ground of the property legally described hereon, and that there are no apparent discrepancies, conflicts, overlapping of improvements, visible utility lines or roads in place, except as shown on the accompanying plat, and that the corner monuments shown thereon were properly placed under my supervision.

TO CERTIFY WHICH, WITNESS by my hand this _____ day of _____, 20____.

Charles G. Walker
Registered Professional Land Surveyor
No. 5283

Preliminary, this document shall not be recorded for any purpose and shall not be used or viewed or relied upon as a final survey document. This document is a "Working Sketch" to show project progress.

Charles G. Walker, RPLS #5283
Release Date December 13, 2017

PERIMETER DESCRIPTION

Perimeter description of a 72.34 acre tract of land, out of the James McOuld Survey, Abstract Number 243, Williamson County, Texas, and being a portion of that certain tract described as 130.856 acres in a Special Warranty Weed to ELR Land Investments, LLC, dated July 6, 2017 and recorded in Document Number 2017063662 of the Official Public Records of Williamson County, Texas, and being more particularly described by metes and bounds as follows:

BEGINNING at a 1/2 inch iron rod with cap inscribed "WALKER 5283" found near a fence corner post in the north margin of County Road 220, a 50' right-of-way, for the most southerly southeast corner of said 130.856 acre tract and this tract;

THENCE: with the north and east margin of said County Road 220, and with the south and west line of said 130.856 acre tract the following seven (7) courses:

1. S 70°04'09" W 1604.67 feet to a 1/2 inch iron rod with cap inscribed "WALKER 5283" found,
2. S 69°50'38" W 696.23 feet to a 1/2 inch iron rod with cap inscribed "WALKER 5283" found,
3. N 82°27'41" W 66.01 feet to a metal T post found,
4. N 63°29'11" W 15.68 feet to a 6 inch cedar fence post found,
5. N 56°09'03" W 17.32 feet to a metal T post found,
6. N 38°38'54" W 67.23 feet to a 1/2 inch iron rod with cap inscribed "WALKER 5283" found,
7. N 20°10'27" W 799.89 feet to a 1/2 inch iron rod found in the south line of that certain tract of described as 289.32 acres in a Warranty Deed with Vendor's Lien to The Mick Family Partnership, Ltd., dated May 6, 1996 and recorded in Document Number 9634556 of the Official Records of Williamson County, Texas, for the most westerly corner of this tract;

THENCE: N 68°22'19" E 742.64 feet with the south line of said 289.32 acre tract, and with a lower northerly line of said 130.856 acre tract to a 1/2 inch iron rod found for an interior ell corner in the west line of said 130.856 acre tract, and for an angle point in the north line of this tract;

THENCE: across said 130.856 acre tract, and continuing with the north line of this tract the following three (3) courses:

1. N 74°00'36" E 644.61 feet to a 1/2 inch iron rod with cap inscribed "WALKER 5283" set for an interior ell corner,
2. N 18°57'33" W 733.71 feet to a 1/2 inch iron rod with cap inscribed "WALKER 5283" set for an angle point,
3. N 72°18'20" E 1146.85 feet to a 1/2 inch iron rod with cap inscribed "WALKER 5283" set in the west margin of County Road 226, same being the east line of said 130.856 acre tract, for the northeast corner of this tract;

THENCE: with the west margin of county Road 226, and with the east line of said 130.856 acre tract the following two (2) courses:

1. S 21°37'26" E 613.45 feet to a 1/2 inch iron rod with cap inscribed "WALKER 5283" found,
2. S 21°15'58" E 835.15 feet to a 1/2 inch iron rod with cap inscribed "WALKER 5283" found,

THENCE: S 32°33'32" W 221.78 feet with a southeasterly line of said 130.856 acre tract to the Point of Beginning.

Bearings cited hereon based on grid north Texas State Plane Coordinate System Central Zone (NAD83).

Plat Notes:

1. Water service for this subdivision will be provided by private on-site wells.
2. Sewer service provided by onsite sewage facility.
3. A ten (10) foot public utility and drainage easement is hereby dedicated adjacent to all property lines unless otherwise noted on the plat. This easement may also be used by individual lot owners to install a water meter and/or water line as needed to access the public water system.
4. A ten (10) foot building line is located adjacent to all property lines unless otherwise noted on the plat.
5. No more than 3 lots may share use of a joint access driveway.
6. Driveway spacing along CR 220 and CR 226 shall be no closer than 100 feet measured center to center.
7. The driveway for lot 5 shall only take access to CR 220.

Williamson County 911 Addressing Coordinator

Road name and address assignments verified this the _____ day of _____, 20____ A.D.

Williamson County Addressing Coordinator

Williamson County & Cities Health District

Based upon the above representations of the engineer or surveyor whose seal is affixed hereto, and after a review of the survey as represented by the said engineer or surveyor, I find that this blue line (survey) complies with the requirements of Edwards Aquifer Regulations for Williamson County and Williamson County On-Site Sewage Facility Regulations. This certification is made solely upon such representations and should not be relied upon for verifications of the facts alleged. The Williamson County Engineer's office and Williamson County disclaim any responsibility to any member of the public for independent verification of the representations, factual or otherwise, contained in this blue line (survey) and the documents associated with it.

J. Terron Evertson, PE, DR, CFM
County Engineer

Date

STATE OF TEXAS §
 § KNOW ALL MEN BY THESE PRESENTS;
COUNTY OF WILLIAMSON §

I, Dan A. Gattis, County Judge of Williamson County, Texas, do hereby certify that this map or plat, with field notes hereon, for a subdivision having been fully presented to the Commissioner's Court of Williamson County, Texas, and by the said Court duly considered, were on this day approved and that this plat is authorized to be registered and recorded in the proper records of the County Clerk of Williamson County, Texas.

Dan A. Gattis, County Judge
Williamson County, Texas

Date

STATE OF TEXAS §
 § KNOW ALL MEN BY THESE PRESENTS;
COUNTY OF WILLIAMSON §

I, Nancy Rister, Clerk of the County Court of said County, do hereby certify that the foregoing instrument in writing, with its certificate of authentication was filed for record in my office on the _____ day of _____, 20____, A.D., at _____ o'clock, ____M., and duly recorded this the _____ day of _____, 20____, A.D., at _____ o'clock, ____M., in the Official Public Records of said County in Document No. _____.

TO CERTIFY WHICH, WITNESS my hand and seal at the County Court of said County, at my office in Georgetown, Texas, the date last shown above written.

Nancy Rister, Clerk County Court
of Williamson County, Texas

By: _____, Deputy

Sheet 2 of 2

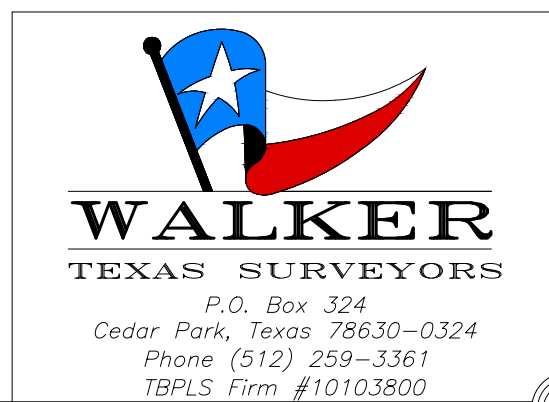

Commissioners Court - Regular Session

21.

Meeting Date: 02/27/2018

Court Cancellation

Submitted By: Wendy Coco, County Judge

Department: County Judge

Agenda Category: Regular Agenda Items

Information

Agenda Item

Discuss and take appropriate action concerning the cancellation of Commissioners Court on March 13th, 2018.

Background

Fiscal Impact

From/To	Acct No.	Description	Amount
---------	----------	-------------	--------

Attachments

No file(s) attached.

Form Review

Inbox

County Judge Exec Asst. (Originator)

Form Started By: Wendy Coco

Final Approval Date: 02/21/2018

Reviewed By

Wendy Coco

Date

02/21/2018 04:29 PM

Started On: 02/21/2018 04:27 PM

Commissioners Court - Regular Session

22.

Meeting Date: 02/27/2018

THF Pub Hearing

Submitted For: Dan Gattis

Submitted By: Hal Hawes, County Judge

Department: County Judge

Agenda Category: Regular Agenda Items

Information

Agenda Item

10:00 AM: Conduct public hearing pursuant to Texas Local Government Code Chapter 392 regarding a resolution to declare a need for a regional housing authority that would include Williamson County due to a shortage of safe or sanitary housing in Williamson County available to low-income persons at rents that they can afford and admitting Williamson County, Texas as a member of the Texas Housing Foundation, a Texas Regional Housing Authority.

Background

Fiscal Impact

From/To	Acct No.	Description	Amount
---------	----------	-------------	--------

Attachments

[THF Resolution](#)

Form Review

Inbox

County Judge Exec Asst.

Form Started By: Hal Hawes

Final Approval Date: 02/07/2018

Reviewed By

Wendy Coco

Date

02/07/2018 03:17 PM

Started On: 02/07/2018 01:32 PM

**RESOLUTION OF THE WILLIAMSON COUNTY COMMISSIONER'S COURT
ADMITTING WILLIAMSON COUNTY, TEXAS AS A MEMBER OF THE TEXAS
HOUSING FOUNDATION, A TEXAS REGIONAL HOUSING AUTHORITY**

RECITALS

WHEREAS, the Texas Housing Foundation is a Texas regional housing authority authorized under state law to provide affordable housing to lower income residents at rentals they can afford;

WHEREAS, there exists in Williamson County, Texas (the "County") a shortage of safe and sanitary housing in the County available to persons of low income at rentals they can afford;

WHEREAS, the Texas Housing Foundation ("THF") has significant experience in providing, developing, financing, and managing safe and sanitary housing developments that are affordable to lower income residents and the THF is currently active in providing affordable housing within the County;

WHEREAS, a county housing authority does not exist within the County;

WHEREAS, the THF is currently comprised of Burnet, Blanco and Llano Counties and now proposes to admit Williamson County, Texas into the THF for the purpose of planning, developing, financing, operating and managing safe and sanitary affordable housing in Williamson County for low-income families, the elderly, and the disabled;

WHEREAS, there is a need to expand the area of operation of the THF into Williamson County and a regional housing authority would be a more efficient and economical administrative unit than a county housing authority if the County is included in the area of operation of the THF, to carry out the purposes of Chapter 392 of the Texas Local Government Code and THF purposes of providing safe and sanitary housing in the County available to persons of low income at rentals they can afford;

WHEREAS, the Texas Local Government Code, Sections 392.018 and 392.033, require the commissioners of a regional housing authority, the commissioners of each county within a regional housing authority and the commissioners of a county outside the regional housing authority to each adopt a resolution declaring a need to include the county that is outside the authority to enter into the regional housing authority; and

WHEREAS, the THF Board of Commissioners has adopted a resolution allowing Williamson County to be admitted into the THF, excluding the parts of the county that are within the territorial boundaries of a municipality pursuant to Section 392.016 of the Texas Local Government Code, for the purpose of planning, developing, financing, operating and managing affordable housing and allowing the THF to exercise its powers within the County; and

WHEREAS, resolutions are or will be placed on the agendas of the County

Commissioners' Courts of Burnet, Blanco and Llano Counties to approve the admission of Williamson County into the THF.

NOW, THEREFORE, BE IT RESOLVED BY THE COUNTY COMMISSIONER'S COURT OF WILLIAMSON COUNTY, TEXAS:

That all of the recitals hereinabove stated are found to be true and correct and are incorporated herein and made a part of this resolution;

That the County Commissioner's Court for each county is the governing body of Burnet County, Blanco County, Llano County, and Williamson County respectively;

That the County Commissioner's Courts of Burnet, Blanco and Llano Counties and the County Commissioner's Court of Williamson County declare that there is a shortage of and a need for safe and sanitary housing that is affordable for lower income residents of Williamson County and that there is a need for the THF to expand its area of operation into Williamson County and to exercise its powers in Williamson County, excluding the parts of the county that are within the territorial boundaries of a municipality pursuant to Section 392.016 of the Texas Local Government Code, to provide said housing and related services to lower income residents of Williamson County at rentals they can afford;

That in accordance with the purposes of THF bylaws and associated organizational documents, as well as the laws of the State of Texas, the THF Board of Commissioners is authorized to add additional member counties to the regional housing authority in order to further its purpose of making safe and sanitary housing available to lower income residents at rentals they can afford and that pursuant to Texas Local Government Code, Section 392.018, the THF Board of Commissioners, by resolution Number 2012-0305, approved the admission of Williamson County into the THF;

That the THF has significant experience in providing, developing, financing, and managing housing developments that are affordable to lower income residents and because THF is currently active in Williamson County, the County Commissioner's Court hereby finds that it is in the best interest of the THF and Williamson County residents and is most efficient and economical to admit Williamson County, pursuant to Texas Local Government Code, Section 392.018, into the THF and resolve to amend THF bylaws to the extent necessary to add a representative member from Williamson County, Texas to the THF Board and to expedite this process in any other manner necessary;

That this County Commissioner's Court hereby resolves to admit Williamson County into the THF, thereby expanding the area of operation of the THF into Williamson County and authorizing THF to exercise its powers in Williamson County, excluding the parts of the county that are within the territorial boundaries of a municipality, for the purpose of providing safe and sanitary housing that is affordable for lower income residents in the County;

That, pursuant to Texas Local Government Code, Section 392.033, the Williamson County Commissioner's Court shall appoint a commissioner for the THF Board of Commissioners to represent Williamson County on the THF Board that is not an officer or

employee of Williamson County and the Williamson County Commissioner's Court shall appoint any successors to that commissioner;

That THF is hereby authorized to exercise its powers under the Texas Housing Authorities Law, Texas Local Government Code, Chapter 392, to assist in the planning, developing, and financing, to operate and otherwise manage affordable housing within Williamson County for low-income families, the elderly, and the disabled of the County at rentals they can afford;

That any member of this County Commissioner's Court and the THF president are authorized to execute all necessary documents between the THF and the County for the purposes stated in this resolution and may take any reasonable and necessary action to effectuate and implement the direction and intention of this resolution, subject to the authorizing resolutions approved by the remaining County Commissioner's Courts representing members of the THF;

That a public hearing was held before the 10th day before the date of this hearing and that the county clerk published notice of the time, place, and purpose of the hearing in a newspaper published in the county or, if no newspaper is published in the county, in a newspaper published in the state with general circulation in the county; and at the hearing, the Williamson County Commissioner's Court shall grant an opportunity to be heard to residents of the County and other interested persons. These actions were taken in addition to required notice provisions of the Open Meetings Act; and

That this County Commissioner's Court resolves and authorizes Williamson County to be admitted into the THF and to allow for a Commissioner residing in Williamson County who is not an officer or employee of Williamson County to be appointed by the Williamson County Commissioner's Court to sit as a commissioner of the THF.

PASSED AND APPROVED this ___ day of _____, 20__.

Williamson County Judge
Honorable Dan A. Gattis

TEXAS HOUSING FOUNDATION

By: _____
Mark Mayfield, President

ATTEST:
By: _____

Commissioners Court - Regular Session

23.

Meeting Date: 02/27/2018

THF Resol Action

Submitted For: Dan Gattis

Submitted By: Hal Hawes, County Judge

Department: County Judge

Agenda Category: Regular Agenda Items

Information

Agenda Item

Discuss, consider and take appropriate action on a resolution declaring a need for a regional housing authority that would include Williamson County due to a shortage of safe or sanitary housing in Williamson County available to low-income persons at rents that they can afford and admitting Williamson County, Texas as a member of the Texas Housing Foundation, a Texas Regional Housing Authority.

Background

Fiscal Impact

From/To	Acct No.	Description	Amount
---------	----------	-------------	--------

Attachments

[THF Resolution](#)

[THF Admitting Resolution](#)

Form Review

Inbox

County Judge Exec Asst.

Form Started By: Hal Hawes

Final Approval Date: 02/07/2018

Reviewed By

Wendy Coco

Date

02/07/2018 03:17 PM

Started On: 02/07/2018 01:42 PM

**RESOLUTION OF THE WILLIAMSON COUNTY COMMISSIONER'S COURT
ADMITTING WILLIAMSON COUNTY, TEXAS AS A MEMBER OF THE TEXAS
HOUSING FOUNDATION, A TEXAS REGIONAL HOUSING AUTHORITY**

RECITALS

WHEREAS, the Texas Housing Foundation is a Texas regional housing authority authorized under state law to provide affordable housing to lower income residents at rentals they can afford;

WHEREAS, there exists in Williamson County, Texas (the "County") a shortage of safe and sanitary housing in the County available to persons of low income at rentals they can afford;

WHEREAS, the Texas Housing Foundation ("THF") has significant experience in providing, developing, financing, and managing safe and sanitary housing developments that are affordable to lower income residents and the THF is currently active in providing affordable housing within the County;

WHEREAS, a county housing authority does not exist within the County;

WHEREAS, the THF is currently comprised of Burnet, Blanco and Llano Counties and now proposes to admit Williamson County, Texas into the THF for the purpose of planning, developing, financing, operating and managing safe and sanitary affordable housing in Williamson County for low-income families, the elderly, and the disabled;

WHEREAS, there is a need to expand the area of operation of the THF into Williamson County and a regional housing authority would be a more efficient and economical administrative unit than a county housing authority if the County is included in the area of operation of the THF, to carry out the purposes of Chapter 392 of the Texas Local Government Code and THF purposes of providing safe and sanitary housing in the County available to persons of low income at rentals they can afford;

WHEREAS, the Texas Local Government Code, Sections 392.018 and 392.033, require the commissioners of a regional housing authority, the commissioners of each county within a regional housing authority and the commissioners of a county outside the regional housing authority to each adopt a resolution declaring a need to include the county that is outside the authority to enter into the regional housing authority; and

WHEREAS, the THF Board of Commissioners has adopted a resolution allowing Williamson County to be admitted into the THF, excluding the parts of the county that are within the territorial boundaries of a municipality pursuant to Section 392.016 of the Texas Local Government Code, for the purpose of planning, developing, financing, operating and managing affordable housing and allowing the THF to exercise its powers within the County; and

WHEREAS, resolutions are or will be placed on the agendas of the County

Commissioners' Courts of Burnet, Blanco and Llano Counties to approve the admission of Williamson County into the THF.

NOW, THEREFORE, BE IT RESOLVED BY THE COUNTY COMMISSIONER'S COURT OF WILLIAMSON COUNTY, TEXAS:

That all of the recitals hereinabove stated are found to be true and correct and are incorporated herein and made a part of this resolution;

That the County Commissioner's Court for each county is the governing body of Burnet County, Blanco County, Llano County, and Williamson County respectively;

That the County Commissioner's Courts of Burnet, Blanco and Llano Counties and the County Commissioner's Court of Williamson County declare that there is a shortage of and a need for safe and sanitary housing that is affordable for lower income residents of Williamson County and that there is a need for the THF to expand its area of operation into Williamson County and to exercise its powers in Williamson County, excluding the parts of the county that are within the territorial boundaries of a municipality pursuant to Section 392.016 of the Texas Local Government Code, to provide said housing and related services to lower income residents of Williamson County at rentals they can afford;

That in accordance with the purposes of THF bylaws and associated organizational documents, as well as the laws of the State of Texas, the THF Board of Commissioners is authorized to add additional member counties to the regional housing authority in order to further its purpose of making safe and sanitary housing available to lower income residents at rentals they can afford and that pursuant to Texas Local Government Code, Section 392.018, the THF Board of Commissioners, by resolution Number 2012-0305, approved the admission of Williamson County into the THF;

That the THF has significant experience in providing, developing, financing, and managing housing developments that are affordable to lower income residents and because THF is currently active in Williamson County, the County Commissioner's Court hereby finds that it is in the best interest of the THF and Williamson County residents and is most efficient and economical to admit Williamson County, pursuant to Texas Local Government Code, Section 392.018, into the THF and resolve to amend THF bylaws to the extent necessary to add a representative member from Williamson County, Texas to the THF Board and to expedite this process in any other manner necessary;

That this County Commissioner's Court hereby resolves to admit Williamson County into the THF, thereby expanding the area of operation of the THF into Williamson County and authorizing THF to exercise its powers in Williamson County, excluding the parts of the county that are within the territorial boundaries of a municipality, for the purpose of providing safe and sanitary housing that is affordable for lower income residents in the County;

That, pursuant to Texas Local Government Code, Section 392.033, the Williamson County Commissioner's Court shall appoint a commissioner for the THF Board of Commissioners to represent Williamson County on the THF Board that is not an officer or

employee of Williamson County and the Williamson County Commissioner's Court shall appoint any successors to that commissioner;

That THF is hereby authorized to exercise its powers under the Texas Housing Authorities Law, Texas Local Government Code, Chapter 392, to assist in the planning, developing, and financing, to operate and otherwise manage affordable housing within Williamson County for low-income families, the elderly, and the disabled of the County at rentals they can afford;

That any member of this County Commissioner's Court and the THF president are authorized to execute all necessary documents between the THF and the County for the purposes stated in this resolution and may take any reasonable and necessary action to effectuate and implement the direction and intention of this resolution, subject to the authorizing resolutions approved by the remaining County Commissioner's Courts representing members of the THF;

That a public hearing was held before the 10th day before the date of this hearing and that the county clerk published notice of the time, place, and purpose of the hearing in a newspaper published in the county or, if no newspaper is published in the county, in a newspaper published in the state with general circulation in the county; and at the hearing, the Williamson County Commissioner's Court shall grant an opportunity to be heard to residents of the County and other interested persons. These actions were taken in addition to required notice provisions of the Open Meetings Act; and

That this County Commissioner's Court resolves and authorizes Williamson County to be admitted into the THF and to allow for a Commissioner residing in Williamson County who is not an officer or employee of Williamson County to be appointed by the Williamson County Commissioner's Court to sit as a commissioner of the THF.

PASSED AND APPROVED this ___ day of _____, 20__.

Williamson County Judge
Honorable Dan A. Gattis

TEXAS HOUSING FOUNDATION

By: _____
Mark Mayfield, President

ATTEST:
By: _____

**TEXAS HOUSING FOUNDATION
RESOLUTION NO. 2012-0305**

Resolving to allow the Texas Housing Foundation, a Texas regional housing authority to admit Williamson County into the Texas Housing Foundation and amend THF bylaws to the extent necessary to add a Williamson County representative to the THF Board of Commissioners

A. Declarations and Premises:

1. The Texas Housing Foundation is a Texas regional housing authority authorized under state law to provide affordable housing to lower income residents at rents they can afford;
2. There exists in Williamson County, Texas a shortage of safe and sanitary housing available to lower income residents at rents they can afford;
3. The Texas Housing Foundation ("THF") has significant experience in providing, developing, financing, and managing housing developments that are affordable to lower income residents and is currently attempting to provide affordable housing to Williamson County residents;
4. It is in the best interest of the THF to admit Williamson County into the THF and to amend THF bylaws to the extent necessary to expedite this process.

B. Resolutions of the Board of Commissioners:

1. In accordance with the purposes of the THF bylaws and associated organizational documents, as well as the laws of the State of Texas, the THF Board of Commissioners is authorized to add additional member counties to the regional housing authority in order to further its purpose of making safe and sanitary housing available to lower income residents at rents they can afford and hereby resolves to admit Williamson County;
2. The THF has formerly declared that there exists in Williamson County a need for safe and sanitary housing and hereby finds and resolves that that the admission of Williamson County into the Texas Housing Foundation will aid in making safe and sanitary housing available to lower income residents of Williamson County at rents they can afford;
3. Because the THF has significant experience in providing, developing, financing, and managing housing developments that are affordable to lower income residents, and because THF is currently active in Williamson County, the THF Board of Commissioners hereby finds that it is in the best interest of the THF and to Williamson County residents to admit Williamson County into the Texas Housing Foundation and to amend THF bylaws to the extent necessary to add a representative member from Williamson County, Texas to the THF Board and to expedite this process in any other manner necessary.
4. The Chair, President & CEO, as well as authorized representatives of the THF shall take any reasonable and necessary action to effectuate the direction and intention of this resolution.

PASSED AND APPROVED March 28th, 2012.

By: Susan C Hamm

Attest: Joe Whaley

Commissioners Court - Regular Session

24.

Meeting Date: 02/27/2018

THF Appointment

Submitted For: Dan Gattis

Submitted By: Hal Hawes, County Judge

Department: County Judge

Agenda Category: Regular Agenda Items

Information

Agenda Item

Discuss, consider and take appropriate action on appointing a commissioner for the Texas Housing Foundation Board of Commissioners to represent Williamson County on the Texas Housing Foundation Board to serve a two (2) year term commencing on March 1, 2018 and ending on February 29, 2020, pursuant to Texas Local Government Code Section 392.033.

Background

Fiscal Impact

From/To	Acct No.	Description	Amount
---------	----------	-------------	--------

Attachments

No file(s) attached.

Form Review

Inbox

County Judge Exec Asst.

Form Started By: Hal Hawes

Final Approval Date: 02/09/2018

Reviewed By

Wendy Coco

Date

02/09/2018 08:12 AM

Started On: 02/08/2018 02:42 PM

Commissioners Court - Regular Session

25.

Meeting Date: 02/27/2018

Discuss consider and take appropriate action on the Department of Infrastructure projects and issues update

Submitted For: Robert Daigh

Submitted By: Lydia Linden, Infrastructure

Department: Infrastructure

Agenda Category: Regular Agenda Items

Information

Agenda Item

Discuss, consider and take appropriate action on the Department of Infrastructure projects and issues update.

Background

Fiscal Impact

From/To	Acct No.	Description	Amount
---------	----------	-------------	--------

Attachments

No file(s) attached.

Form Review

Inbox

County Judge Exec Asst.
Form Started By: Lydia Linden
Final Approval Date: 01/23/2018

Reviewed By

Wendy Coco

Date

01/23/2018 02:22 PM
Started On: 01/23/2018 12:47 PM

Commissioners Court - Regular Session

26.

Meeting Date: 02/27/2018

Road Bond Construction Summary Report

Submitted By: Dawn Haggard, Road Bond

Department: Road Bond

Agenda Category: Regular Agenda Items

Information

Agenda Item

Receive and acknowledge the February 2018 Construction Summary Report for the Road Bond Program.

Background

Fiscal Impact

From/To	Acct No.	Description	Amount
---------	----------	-------------	--------

Attachments

[February 2018 CSR](#)

Form Review

Inbox

County Judge Exec Asst.

Form Started By: Dawn Haggard

Final Approval Date: 02/22/2018

Reviewed By

Wendy Coco

Date

02/22/2018 08:28 AM

Started On: 02/20/2018 02:23 PM



ROAD BOND PROGRAM

Construction Summary Report

County Judge
Dan Gattis

Commissioners
Terry Cook
Cynthia Long
Valerie Covey
Larry Madsen

February 2018

WWW.ROADBOND.ORG

Volume XVII - Issue No.02

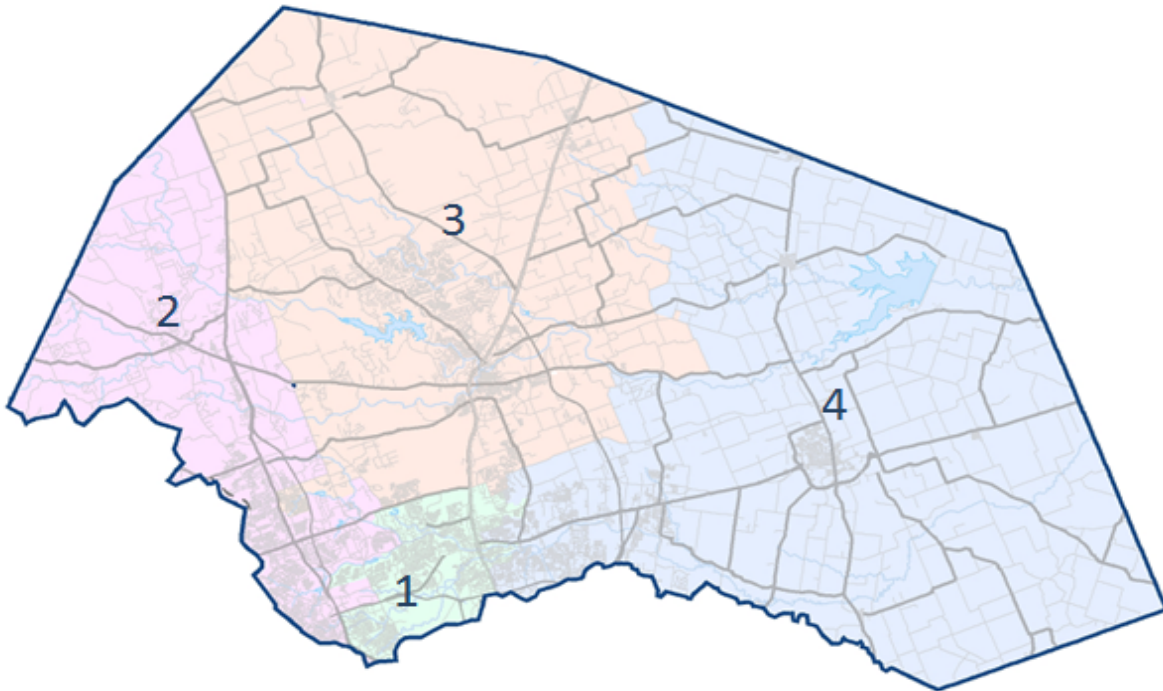

Presented By:



PRIME
STRATEGIES,
INC.

HNTB

Table of Contents



Completed Projects..... 1

PRECINCT No. 1 – Commissioner Terry Cook 4

 Forest North Drainage Phase 1 6

 Pearson Ranch Road (Iveans to SH 45 ROW) 8

 RM 620 Phase 2 (Wyoming Springs to Deep Wood) 9

PRECINCT No. 2 – Commissioner Cynthia Long 11

 CR 258 (Sunset Ridge to Ronald Reagan Blvd) 13

PRECINCT No. 3 – Commissioner Valerie Covey 15

 Arterial H Ph 1 (Sam Bass Road to existing Arterial H) 17

 Southwest Bypass Segment 1 (Southbound IH 35 to .5 miles west)..... 19

 Inner Loop Improvements (WilCo Way to Belmont Dr.) 21

 Williamson County Regional Raw Water Line..... 23

PRECINCT No. 4 – Commissioner Larry Madsen 25

 CR 110 South (US 79 to Limmer Loop)..... 27

 CR 119 (Limmer Loop to Chandler Rd) 29

WILLIAMSON COUNTY

ROAD BOND PROGRAM

COMPLETED PROJECTS

CONSTRUCTION SUBSTANTIALLY COMPLETE/OPEN TO TRAFFIC - AS OF JANUARY 2018

Precinct 1

- Pond Springs Road (signal) – Apr 2002
- McNeil Road, Phase 1 – Jan 2005
- McNeil Road, Phase 2 – Feb 2007
- RM 620, Phase 1 – Jan 2009
- Pond Springs Road – Sep 2010
- County Road 174 at Brushy Creek – Jun 2011
- O'Connor Drive Extension – Apr 2012
- King of Kings Crossing – Aug 2012
- RM 620 Safety Improvements – Dec 2014
- Pearson Ranch Road – Oct 2017
- Forest North Phase 2 – Oct 2017

Precinct 2

- RM 1869 at SH 29 (signal) – Aug 2002
- River Bend Oaks – Feb 2003
- County Road 175 – Jun 2003
- County Road 200 – Sep 2003
- Ronald Reagan Blvd, South Ph. 1 – Dec 2004
- County Road 214 – Feb 2005
- County Road 258 – Sep 2006
- San Gabriel Pkwy, Ph. 1 – Feb 2007
- Ronald Reagan Blvd North Ph. 1 – Mar 2007
- Lakeline Blvd – Jul 2007
- Ronald Reagan Blvd South Ph. 2 – Feb 2008
- US 183 at CR 274 – Feb 2008
- County Road 175 Phase 2A – Jan 2010
- US 183 at FM 3405 Traffic Signal – Mar 2010
- US 183 at FM 3405 Left Turn Lanes – May 2010
- County Road 214 Phase 2A – Jan 2011
- San Gabriel Parkway Ph. 2 – Oct 2011
- US 183 (PTF) – Apr 2012
- SH 29 TWLTL Liberty Hill – Dec 2012
- Hero Way – Feb 2013
- County Roads 260/266 – Apr 2013
- County Road 277 – Jul 2014
- Lakeline Blvd at US 183 – Nov 2014
- Lakeline Blvd Ph. 2 – Apr 2015
- County Road 258 – Jul 2017

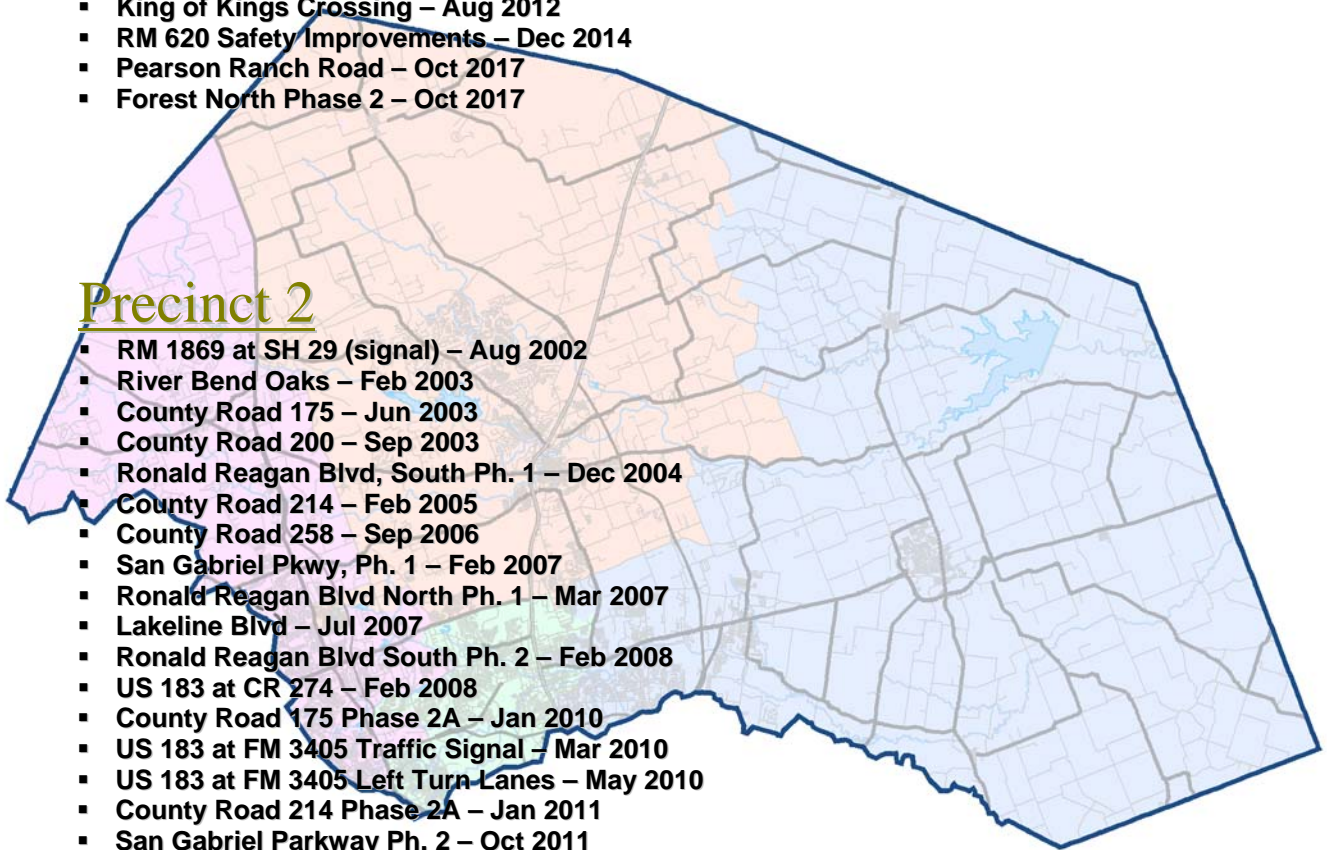

WILLIAMSON COUNTY

ROAD BOND PROGRAM

COMPLETED PROJECTS

CONSTRUCTION SUBSTANTIALLY COMPLETE/OPEN TO TRAFFIC - AS OF JANUARY 2018

Precinct 3

- Cedar Hollow at SH 29 (signal) – Aug 2002
- Georgetown Inner Loop Project 2 – Aug 2003
- Georgetown Inner Loop Project 1 – Jun 2004
- Georgetown Inner Loop East Extension – Sep 2004
- County Road 152 Bridge Replacement – Sep 2004
- Inner Loop East (CR 151 to Bus 35) – Oct 2005
- Ronald Reagan Blvd North, Ph. 2 – May 2008
- 12" Water Main Relocation for SH 29 Widening – Jun 2008
- SH 29 / CR 104, Ph. 1 – Jul 2008
- IH 35 at SH 29 Turnarounds (PTF) – Aug 2008
- SE Inner Loop at FM 1460 – Nov 2009
- County Road 111 (Westinghouse Road) – Jun 2010
- Williams Drive – Apr 2011
- County Road 104, Phase 2 – May 2011
- RM 2338 (PTF) – Jul 2011
- SH 29 at Park Pl and Jack Nicklaus – May 2012
- Ronald Reagan Blvd. North Phase 3 – Jun 2013
- Ronald Reagan Blvd. North Phase 4 – Mar 2014
- Madrid Drive Extension – Sep 2014
- CR 245 – Sep 2015
- IH 35 Northbound Frontage Road (PTF) – Oct 2015
- Ronald Reagan North Phase 4 Fencing – Jan 2016
- IH 35 Northbound Frontage Road Driveway (PTF) – Mar 2016
- Southwest Bypass Driveways – Aug 2016
- RM 2243 at Escalera Right Turn Lane – Aug 2016
- SH 29 at Cedar Hollow Right Turn Lane – Aug 2016
- Southwest Bypass Access Route – Jul 2017

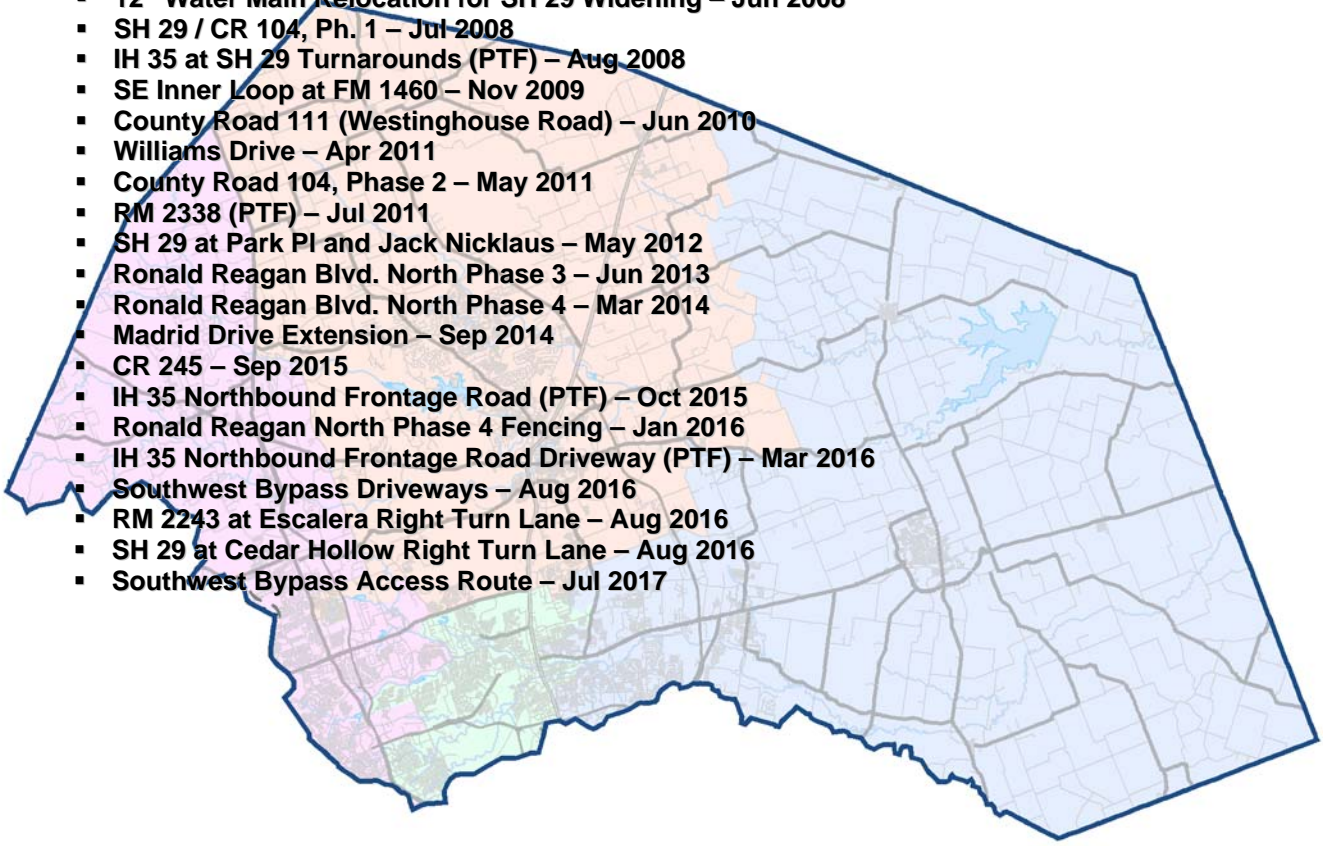

WILLIAMSON COUNTY

ROAD BOND PROGRAM

COMPLETED PROJECTS

CONSTRUCTION SUBSTANTIALLY COMPLETE/OPEN TO TRAFFIC - AS OF JANUARY 2018

Precinct 4

- **Bridge Replacements (CR 390, 406 & 427) – Nov 2002**
- **County Road 368 and 369 – Nov 2002**
- **County Road 412 – Aug 2003**
- **County Road 300 and 301 – Dec 2003**
- **County Road 424 Bridge Replacement – Jan 2004**
- **Chandler Rd. Extension, Ph. 1 – Mar 2005**
- **County Road 112, Ph. 1 – Aug 2005**
- **County Road 137 – Oct 2005**
- **Limmer Loop, Ph. 1A – Jul 2006**
- **Chandler Rd, Ph. 2 – Dec 2007**
- **Limmer Loop, Ph. 1B – Mar 2008**
- **Limmer Loop, Ph. 1C – Oct 2008**
- **US 79, Section 5B (PTF) – Aug 2010**
- **Chandler Rd, Ph. 3B – Oct 2010**
- **US 79, Section 5A (PTF) – May 2011**
- **FM1660 at Landfill Rd. – Sep 2011**
- **Second Street Drainage Improvements – Dec 2011**
- **US 79 Section 3 (PTF) – Jul 2012**
- **Chandler Rd, Ph. 3A – Dec 2012**
- **Second Street Roadway Improvements – Feb 2013**
- **County Road 138 – Jun 2013**
- **County Road 108 – Nov 2013**
- **County Road 170 – Feb 2015**
- **Multi Site Traffic Signals – Jun 2016**
- **Bill Pickett Trail (East Williamson County Expo Center Access Road) – Nov 2016**

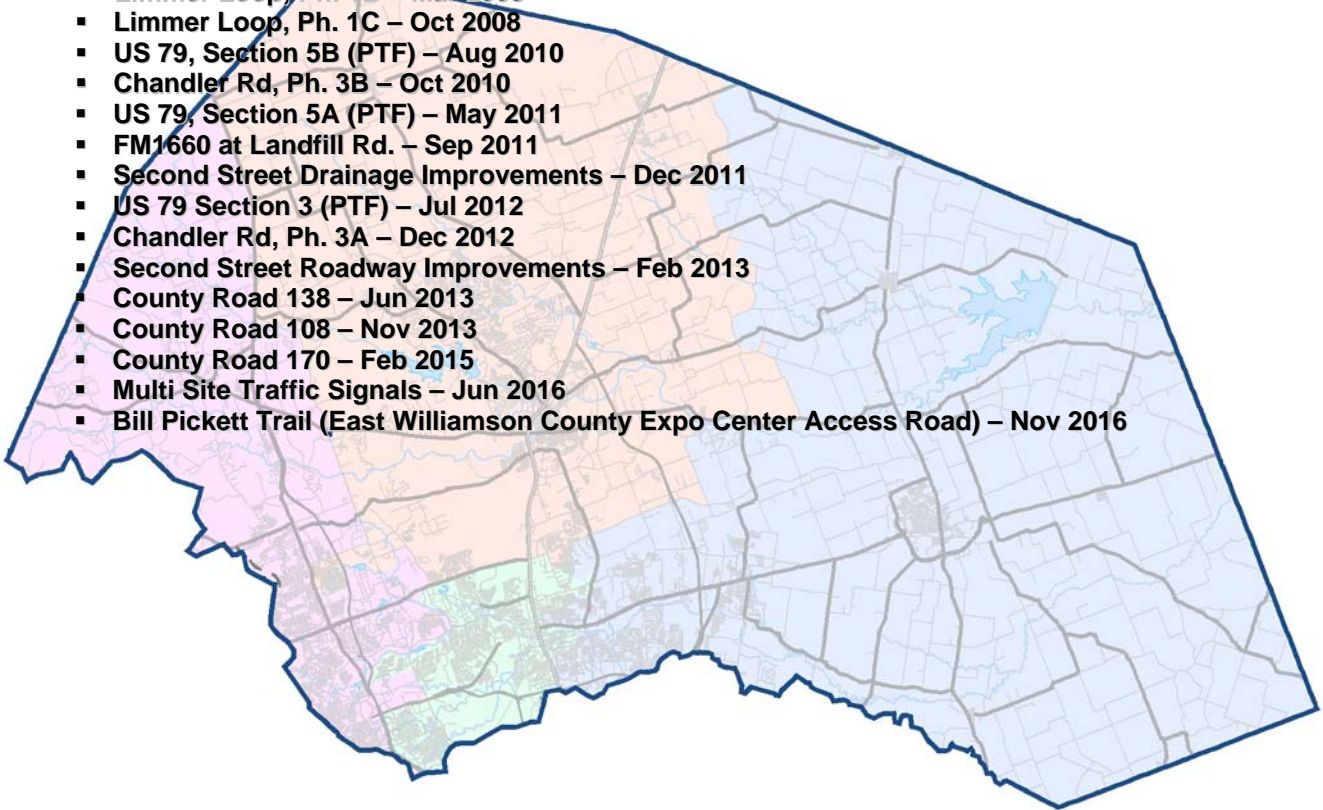

2006 ROAD BOND PROGRAM PROJECTS

PRECINCT 1 - COMMISSIONER COOK

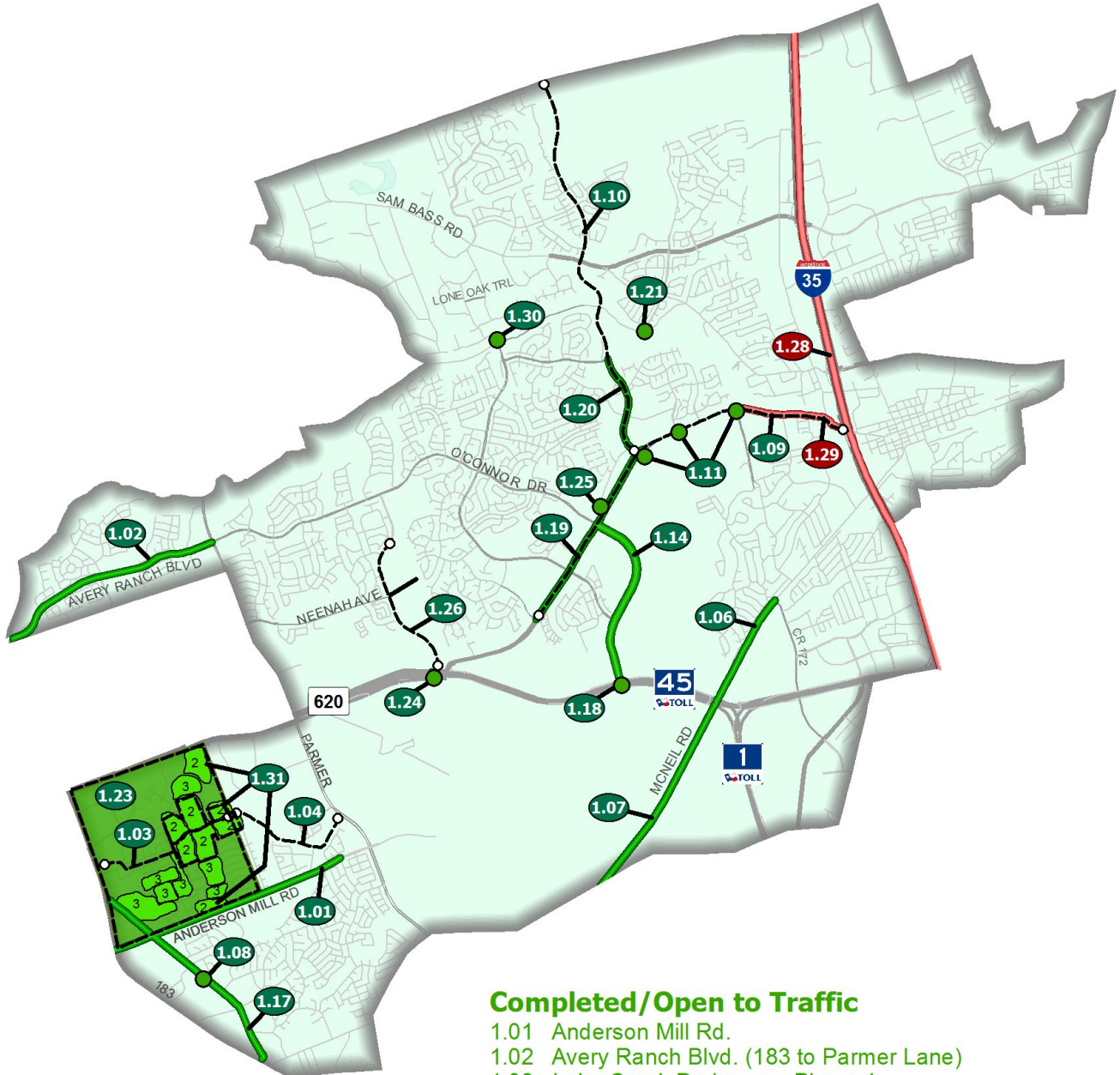

Completed/Open to Traffic

- 1.01 Anderson Mill Rd.
- 1.02 Avery Ranch Blvd. (183 to Parmer Lane)
- 1.03 Lake Creek Drainage – Phase 1 ○—○
- 1.04 Lake Creek Drainage – Phase 2 ○—○
- 1.06 McNeil Road - Phase 1
- 1.07 McNeil Road - Phase 2
- 1.08 Pond Springs at Turtle Rock Signal
- 1.09 RM 620 Feasibility Study ○—○
- 1.10 Wyoming Springs North Study ○—○
- 1.11 RM 620 Interim Improvements – Phase 1
- 1.14 O'Connor Extension
- 1.17 Pond Springs Road
- 1.18 O'Connor Overpass at SH 45
- 1.19 RM 620 (Cornerwood Dr. to Wyoming Springs)
- 1.20 Wyoming Springs (620 to Brightwater Blvd.)
- 1.21 CR 174 (Hairy Man Rd.) Bridge Rail Rehab
- 1.23 Forest North Drainage Study - Phase 1 []
- 1.25 King of Kings Crossing
- 1.26 Pearson Ranch Road (Design) ○—○
- 1.24 Pearson Ranch Underpass at SH 45/ RM 620
- 1.30 Great Oaks at Brushy Creek (design)
- 1.31 Forest North Drainage Improvements - Phase 2 (design) []
- 1.31 Forest North Drainage Improvements - Phase 3 (design) []

In Design

- 1.28 IH 35 Operational Analysis
- 1.29 RM 620 (IH 35 to Deep Wood Dr.)

2013 ROAD BOND PROGRAM PROJECTS

PRECINCT 1 - COMMISSIONER COOK

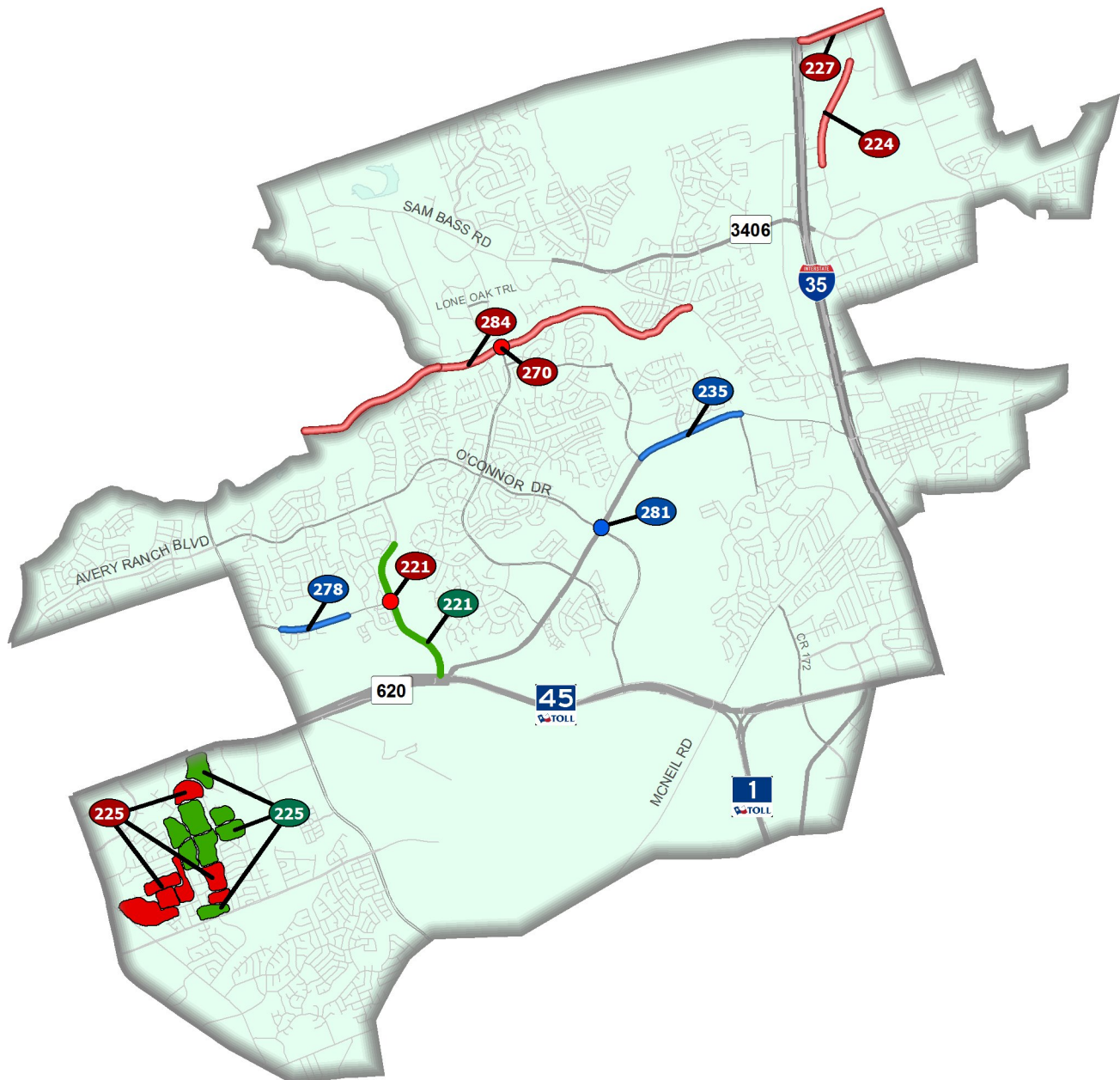

Completed/Open to Traffic

- 221 Pearson Ranch Road
- 225 Forest North Drainage Improvements - Phase 2

Under Construction/Bidding

- 235 RM 620 Phase 2 (Wyoming Springs to Deep Wood Drive)
- 278 Neenah Avenue Widening (Olive Hill Drive to end)
- 281 O'Connor Drive North of RM 620 (Traffic Signal)

In Design

- 221 Pearson Ranch Road (Signal)
- 224 North Mays Street Extension (La Paloma to Oakmont Dr.)
- 225 Forest North Drainage Improvements - Phase 3
- 227 University Blvd Widening (IH 35 to Sunrise Rd.)
- 270 Great Oaks at Brushy Creek
- 284 Hairy Man Rd/Brushy Creek Rd Safety Improvements (Arrowhead Trail to Sam Bass Road)

**Forest North Drainage Ph 1
Project No. 1604-068**

Original Contract Price = \$3,556,659.50

<u>Letting</u>	<u>Award</u>	<u>Notice To Proceed</u>	<u>Begin Work</u>	<u>Substantial Completion</u>	<u>Work Accepted</u>	<u>Total Bid Days</u>	<u>Days Added</u>	<u>Total Days</u>	
6/9/2016	7/1/2016	8/1/2016	8/11/2016	10/18/2017		600	35	635	
<u>Invoice Number</u>	<u>Beginning Date</u>	<u>Ending Date</u>	<u>Days Charged</u>	<u>Current Invoice</u>	<u>Invoice Total</u>	<u>Current Retainage</u>	<u>Total Retainage</u>	<u>% (\$ Used)</u>	<u>% Time Used</u>
1	8/11/2016	8/31/2016	21	\$152,734.50	\$152,734.50	\$16,970.50	\$16,970.50	5	3
2	9/1/2016	9/30/2016	30	\$208,685.70	\$361,420.20	\$23,187.30	\$40,157.80	11	8
3	10/1/2016	10/31/2016	31	\$266,921.68	\$628,341.88	\$29,657.96	\$69,815.76	19	13
4	11/1/2016	12/2/2016	32	\$182,471.22	\$810,813.10	\$20,274.58	\$90,090.34	24	18
5	12/3/2016	12/31/2016	29	\$177,314.98	\$988,128.08	\$19,701.67	\$109,792.01	29	23
6	1/1/2017	1/31/2017	31	\$231,302.70	\$1,219,430.78	\$25,700.30	\$135,492.31	36	27
7	2/1/2017	2/28/2017	28	\$304,664.67	\$1,524,095.45	\$33,851.63	\$169,343.94	45	32
8	3/1/2017	3/31/2017	31	\$191,005.20	\$1,715,100.65	\$21,222.80	\$190,566.74	51	37
9	4/1/2017	4/30/2017	30	\$172,795.55	\$1,887,896.20	\$19,199.50	\$209,766.24	56	41
10	5/1/2017	5/31/2017	31	\$229,295.63	\$2,117,191.83	\$25,477.30	\$235,243.54	63	46
11	6/1/2017	6/30/2017	30	\$317,805.27	\$2,434,997.10	\$35,308.69	\$270,552.23	73	51
12	7/1/2017	7/31/2017	31	\$387,533.28	\$2,822,530.38	\$43,062.26	\$313,614.49	84	56
13	8/1/2017	8/31/2017	31	\$284,111.91	\$3,106,642.29	\$31,567.98	\$345,182.47	93	61
14	9/1/2017	9/30/2017	30	\$329,371.39	\$3,436,013.68	-\$164,339.65	\$180,842.82	97	66
15	10/1/2017	10/31/2017	31	\$98,274.32	\$3,534,288.00	\$5,172.34	\$186,015.16	100	70

2/2/2018 Comments - The Close Out Documents are being reviewed.

<u>Change Order Number</u>	<u>Approved</u>	<u>Cost This CO</u>	<u>Total COs</u>
01	3/21/2017	31,806.00	31,806.00

1A: Design Error or Omission. Incorrect PS&E. This Change Order revises work along Broadmeade Ave., between Sherbrooke St. and Meadowheath Dr in the Sherbrooke zone. The original plans called for a ditch in this location but, due to the depth of the original planned ditch, which created slopes steeper than 3:1, the ditch was replaced with an underground storm sewer system with inlets. 3F: County Convenience. Additional work desired by the County. New pay items have been added to the contract to reimburse the contractor for removal of trees larger than what was called out in the original contract.

<u>Change Order Number</u>	<u>Approved</u>	<u>Cost This CO</u>	<u>Total COs</u>
02	5/23/2017	58,006.83	89,812.83

2G: Differing Site Conditions (unforeseeable). Unadjusted utility (unforeseeable). This Change Order compensates the Contractor for the removal and relocation of an existing water line that is in conflict with the proposed storm sewer line BB1 at the corner of Broadmeade Avenue and Braeburn Glen. 4B: Third Party Accommodation. Third party requested work. This change order also compensates the Contractor for completed trench repair of the asbestos line that is being removed. A portion of the trench repair quantity has been added to this change order. The remaining quantity will be added to a future change order. The City of Austin has agreed to compensate the Contractor for these costs.

<u>Change Order Number</u>	<u>Approved</u>	<u>Cost This CO</u>	<u>Total COs</u>
03	8/22/2017	91,734.95	181,547.78

3F: County Convenience. Additional work desired by the County. This Change Order revises drainage work in the Braeburn, Stillforest and Wisterwood Zones. The cost of the additional work was paid by overruling existing pay items where possible or for work not covered by an existing pay item, the cost of the work was tracked by force account (time and materials).

<u>Change Order Number</u>	<u>Approved</u>	<u>Cost This CO</u>	<u>Total COs</u>
04	8/22/2017	59,124.65	240,672.43

3F: County Convenience. Additional work desired by the County. This Change Order revises drainage work at the corner of Broadmeade and Sherbrooke Street in the Sherbrooke Zone. After review, the County requested that the open ditch design be changed to an underground pipe system due the the depth of the ditches.

<u>Change Order Number</u>	<u>Approved</u>	<u>Cost This CO</u>	<u>Total COs</u>
05	9/26/2017	65,103.79	305,776.22

3F: County Convenience. Additional work desired by the County. This Change Order revises drainage work in the Braeburn, Stillforest and Wisterwood Zones. The cost of the additional work was paid by overruling existing pay items where possible or for work not covered by an existing pay item, the cost of the work was tracked by force account (time and materials).

<u>Change Order Number</u>	<u>Approved</u>	<u>Cost This CO</u>	<u>Total COs</u>
06	9/26/2017	29,148.01	334,924.23

3F: County Convenience. Additional work desired by the County. This Change Order revises drainage work at the corner of Broadmeade and Sherbrooke Street in the Sherbrooke Zone. After review, the County requested that the open ditch design be changed to an underground pipe system due the the depth of the ditches.

<u>Change Order Number</u>	<u>Approved</u>	<u>Cost This CO</u>	<u>Total COs</u>
07	1/16/2018	-55,044.67	279,879.56

2E: Differing Site Conditions (unforeseeable). Miscellaneous difference in site conditions (unforeseeable) (Item 9). This Change Order provides the final balancing for the overrun/underrun of Contract quantities for the portion of the items paid for by Williamson County. Changes to final quantities on the project were the result of addressing field conditions not accounted for in the original plans.

Change Order Number
08

Approved
1/16/2018

Cost This CO
-108,905.22

Total COs
170,974.34

2E: Differing Site Conditions (unforeseeable). Miscellaneous difference in site conditions (unforeseeable) (Item 9). This Change Order provides the final balancing for the overrun/underrun of Contract quantities for the items paid for by the City of Austin. Changes to the final quantities on the project were the result of addressing field conditions not accounted for in the original plans. All final pay quantities were reviewed and approved by the City of Austin.

Adjusted Price = \$3,727,633.84

**Pearson Ranch Road (Iveans Way to RM 620)
Project No. 1607-102**

Original Contract Price = \$4,516,178.77

<u>Letting</u>	<u>Award</u>	<u>Notice To Proceed</u>	<u>Begin Work</u>	<u>Substantial Completion</u>	<u>Work Accepted</u>	<u>Total Bid Days</u>	<u>Days Added</u>	<u>Total Days</u>	
9/20/2016	10/11/2016	11/18/2016	11/28/2016	10/13/2017		330	0	330	
<u>Invoice Number</u>	<u>Beginning Date</u>	<u>Ending Date</u>	<u>Days Charged</u>	<u>Current Invoice</u>	<u>Invoice Total</u>	<u>Current Retainage</u>	<u>Total Retainage</u>	<u>% (\$ Used)</u>	<u>% Time Used</u>
1	11/28/2016	11/30/2016	3	\$195,710.04	\$195,710.04	\$21,745.56	\$21,745.56	5	1
2	12/1/2016	12/31/2016	31	\$243,555.13	\$439,265.17	\$27,061.68	\$48,807.24	11	10
3	1/1/2017	1/31/2017	31	\$202,139.71	\$641,404.88	\$22,459.97	\$71,267.21	16	20
4	2/1/2017	2/28/2017	28	\$508,271.85	\$1,149,676.73	\$56,474.65	\$127,741.86	29	28
5	3/1/2017	3/31/2017	31	\$369,038.84	\$1,518,715.57	\$41,004.32	\$168,746.18	38	38
6	4/1/2017	4/30/2017	30	\$330,336.72	\$1,849,052.29	\$36,704.08	\$205,450.26	46	47
7	5/1/2017	5/31/2017	31	\$492,086.42	\$2,341,138.71	-\$82,232.43	\$123,217.83	56	56
8	6/1/2017	6/30/2017	30	\$372,704.74	\$2,713,843.45	\$19,616.04	\$142,833.87	64	65
9	7/1/2017	7/31/2017	31	\$813,710.22	\$3,527,553.67	\$42,826.85	\$185,660.72	84	75
10	8/1/2017	8/31/2017	31	\$188,607.77	\$3,716,161.44	\$9,926.71	\$195,587.43	88	84
11	9/1/2017	9/30/2017	30	\$125,552.68	\$3,841,714.12	\$6,608.03	\$202,195.46	91	93
12	10/1/2017	10/31/2017	14	\$169,295.90	\$4,011,010.02	\$8,910.31	\$211,105.77	95	97
13	11/1/2017	11/30/2017	0	\$27,717.20	\$4,038,727.22	\$1,458.80	\$212,564.57	96	97

2/1/2018 Comments - The Contractor has submitted the Close-Out Documents which are under review.

<u>Change Order Number</u>	<u>Approved</u>	<u>Cost This CO</u>	<u>Total COs</u>
01	5/16/2017	-92,621.70	-92,621.70

4B: Third Party Accommodation. Third party requested work (reduction in scope). This Change Order revises the City of Austin (COA) water and wastewater (W&WW) work shown in the original plans. The COA requested that the installation of the 8" and 24" pipe and related items be deleted from the contract. The COA funded the water and wastewater work shown in the plans and will get the credit for the reduction in cost to the contract.

<u>Change Order Number</u>	<u>Approved</u>	<u>Cost This CO</u>	<u>Total COs</u>
02	6/13/2017	11,553.00	-81,068.70

2C: Differing Site Conditions (unforeseeable). New development (conditions changing after PS&E completed). This Change Order revises the pay items for the intersection tie-in work at Neenah Avenue and Pearson Ranch Road. The tie-in location was adjusted 25' to provide a smooth profile through the intersection. This change extends the limits of Neenah reconstruction west of Pearson Ranch Road.

<u>Change Order Number</u>	<u>Approved</u>	<u>Cost This CO</u>	<u>Total COs</u>
03	10/3/2017	921.34	-80,147.36

3H: County Convenience. Cost savings opportunity discovered during construction. This Change Order revises the method of pavement marking elimination that results in a cost savings to the project. 1A: Design Error or Omission. Incorrect PS&E. Changes to plan quantities are documented for various pay items.

Adjusted Price = \$4,436,031.41

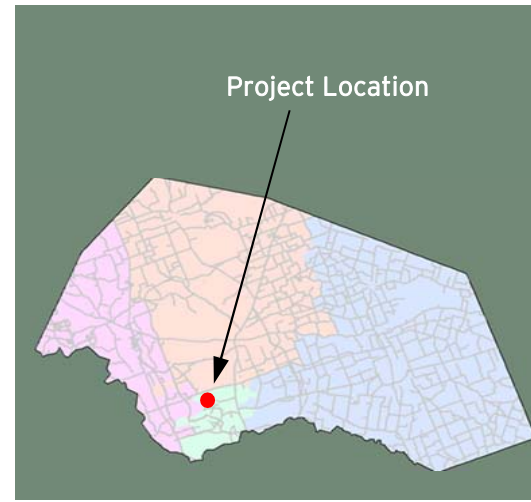

RM 620 Phase 2

(Wyoming Springs to Deep Wood Drive)

Project Length: .9 Miles

Roadway Classification: Urban Principal Arterial

Project Schedule: January 2017-March 2018

Estimated Construction Cost: \$6.1 Million



JANUARY 2018 IN REVIEW

01/05/2018: Cox Commercial Construction placed and compacted flexible base between Driveway 3 and the Hospital Emergency Entrance and at Driveway 8.

01/12/2018: Subcontractor Greater Austin formed and placed concrete walls and decks on inlets at Oaklands. Concrete was placed at Driveways 8 and 9 between Deep Wood and Oaklands. Curb was slipformed between Oakwoods and the Hospital Entrance.

01/19/2018: The Contractor backfilled behind curb at Block Walls 1 and 2 and between Driveway 3 and the Hospital Emergency Entrance. Subcontractor Greater Austin formed Driveway 10 and formed and placed concrete at Driveway 3. Subcontractor Austin Traffic Signal installed conduit from the signal box to the power pole.

01/26/2018: Sidewalk was graded at Block Wall 1 and riprap was placed and graded at Block Wall 2. Subcontractor Greater Austin placed concrete for Driveway 6 and at the Hospital Emergency Entrance. Curb and gutter was placed at the inlet transitions and the Hospital Entrance. Subcontractor Austin Traffic Signal placed the Hospital sign at the entrance.



Design Engineer: Half Associates
 Contractor: Cox Commercial Construction
 Construction Observation: Clayton Weber, HNTB

Williamson County
 Road Bond Program

**RM 620 Safety Improvements (Wyoming Springs to Deep Wood)
Project No. 1608-108**

Original Contract Price = \$6,082,225.70

<u>Letting</u>	<u>Award</u>	<u>Notice To Proceed</u>	<u>Begin Work</u>	<u>Substantially Complete</u>	<u>Work Accepted</u>	<u>Total Bid Days</u>	<u>Days Added</u>	<u>Total Days</u>
9/28/2016	11/30/2016	1/3/2017	1/13/2017			425	0	425
<u>Invoice Number</u>	<u>Beginning Date</u>	<u>Ending Date</u>	<u>Days Charged</u>	<u>Current Invoice</u>	<u>Invoice Total</u>	<u>% (\$) Used</u>	<u>% Time Used</u>	
1	1/13/2017	1/31/2017	19	\$459,169.50	\$459,169.50	7	4	
2	2/1/2017	2/28/2017	28	\$280,194.00	\$739,363.50	12	11	
3	3/1/2017	3/31/2017	31	\$389,047.00	\$1,128,410.50	18	18	
4	4/1/2017	4/30/2017	30	\$516,962.84	\$1,645,373.34	27	25	
5	5/1/2017	5/31/2017	31	\$285,725.66	\$1,931,099.00	31	33	
6	6/1/2017	6/30/2017	30	\$313,267.57	\$2,244,366.57	37	40	
7	7/1/2017	7/31/2017	31	\$274,834.20	\$2,519,200.77	41	47	
8	8/1/2017	8/31/2017	31	\$285,281.13	\$2,804,481.90	46	54	
9	9/1/2017	9/30/2017	30	\$368,485.34	\$3,172,967.24	52	61	
10	10/1/2017	10/31/2017	31	\$299,932.60	\$3,472,899.84	57	69	
11	11/1/2017	11/30/2017	30	\$234,228.72	\$3,707,128.56	60	76	
12	12/1/2017	12/31/2017	31	\$154,371.19	\$3,861,499.75	63	83	
13	1/1/2018	1/31/2018	31	\$349,918.70	\$4,211,418.45	69	90	

<u>Change Order Number</u>	<u>Approved</u>	<u>Cost This CO</u>	<u>Total COs</u>
01	10/3/2017	7,495.80	7,495.80

2E: Differing Site Conditions (unforeseeable). Miscellaneous difference in site conditions (unforeseeable). This change order adds revisions to the drainage system along Oaklands Drive, and the west end connection to the existing box culvert. 3H: County Convenience. Cost savings opportunity discovered during construction. This Change Order changed the full depth reconstruction on the east end of the project to level up with hot mix on the existing pavement which eliminated traffic control phases that results in a cost savings for the County.

<u>Change Order Number</u>	<u>Approved</u>	<u>Cost This CO</u>	<u>Total COs</u>
02	1/30/2018	49,456.20	56,952.00

2E: Differing Site Conditions (unforeseeable). Miscellaneous difference in site conditions (unforeseeable). This Change Order revises the drainage inlets along Oaklands Drive. 3E: County Convenience. Reduction of future maintenance. This Change Order revises the signal conduits and controller cabinet at Oaklands Drive and RM 620.

Adjusted Price = \$6,139,177.70

2006 ROAD BOND PROGRAM PROJECTS

PRECINCT 2 - COMMISSIONER LONG

Completed/Open to Traffic

- 2.01 Vista Ridge Blvd.
- 2.03 Brushy Creek Road
- 2.05 Cypress Creek Road
- 2.06 Lakeline Blvd. (Crystal Falls Pkwy to New Hope Dr)
- 2.07 River Bend Oaks Subdivision
- 2.08 Ronald W. Reagan South – Phase 1
- 2.09 Ronald W. Reagan North – Phase 1
- 2.10 CR 175 (RM 1431 to Regional Park)
- 2.11 CR 185
- 2.12 CR 200 (CR 201 to Lackey Creek)
- 2.13 CR 214 (SH 29 to Rolling Hills Dr.)
- 2.14 CR 258 (US 183 to Sunset Ridge)
- 2.15 RM 1869 at SH 29
- 2.16 Lakeline Blvd. (Lyndhurst to Parmer)
- 2.17 San Gabriel Parkway – Phase 1
- 2.18 US 183 Widening at CR 274
- 2.19 Ronald W. Reagan South – Phase 2
- 2.20 Kauffman Loop
- 2.21 CR 175 Extension – Phase 2A
- 2.22 CR 179
- 2.23 San Gabriel Parkway – Phase 2
- 2.24 CR 214 – Phase 2A
- 2.25 CR 214 – Phase 2B Schematic ○ - ○
- 2.26 SH 29 Improvements Study & Schematic ○ - ○
- 2.27 US 183 (PTF)
- 2.28 CR 272
- 2.31 Brushy Creek Road
- 2.32 RM 1431
- 2.34 Hero Way
- 2.35 US 183 at FM 3405 Traffic Signal
- 2.36 US 183 at FM 3405 Left Turn Lane
- 2.37 SH 29 TWLTL in Liberty Hill
- 2.38 CR 260 / CR 266 at SH 29
- 2.40 Lakeline Blvd. Phase 2 (Old Quarry Rd. to Old 2243)
- 2.41 Seward Junction Improvements Study ○ - ○
- 2.42 San Gabriel Parkway West
- 2.44 US 183 at RM 1869
- 2.45 Lakeline Blvd. at US 183
- 2.46 CR 258 (Sunset Ridge to Reagan Blvd) (Design) ○ - ○
- 2.47 Lakeline Blvd. Phase 3 (Crystal Falls Pkwy. to Old Quarry Rd.)
- 2.48 Seward Junction Schematic (SE and SW) ○ - ○
- 2.50 Bagdad Rd. North Phase 2 Schematic (CR 280 to SH 29) ○ - ○
- 2.52 RM 1431 at Parmer/ Reagan CF
- 2.53 Cypress Creek Road at US 183
- 2.54 CR 272 Overlay
- 2.55 Brushy Creek East Overlay
- 2.56 Cypress Creek Road at Lakeline
- 2.57 Brushy Creek Road at Parmer Lane

In Design

- 2.49 Lakeline Blvd. Right Turn Lanes

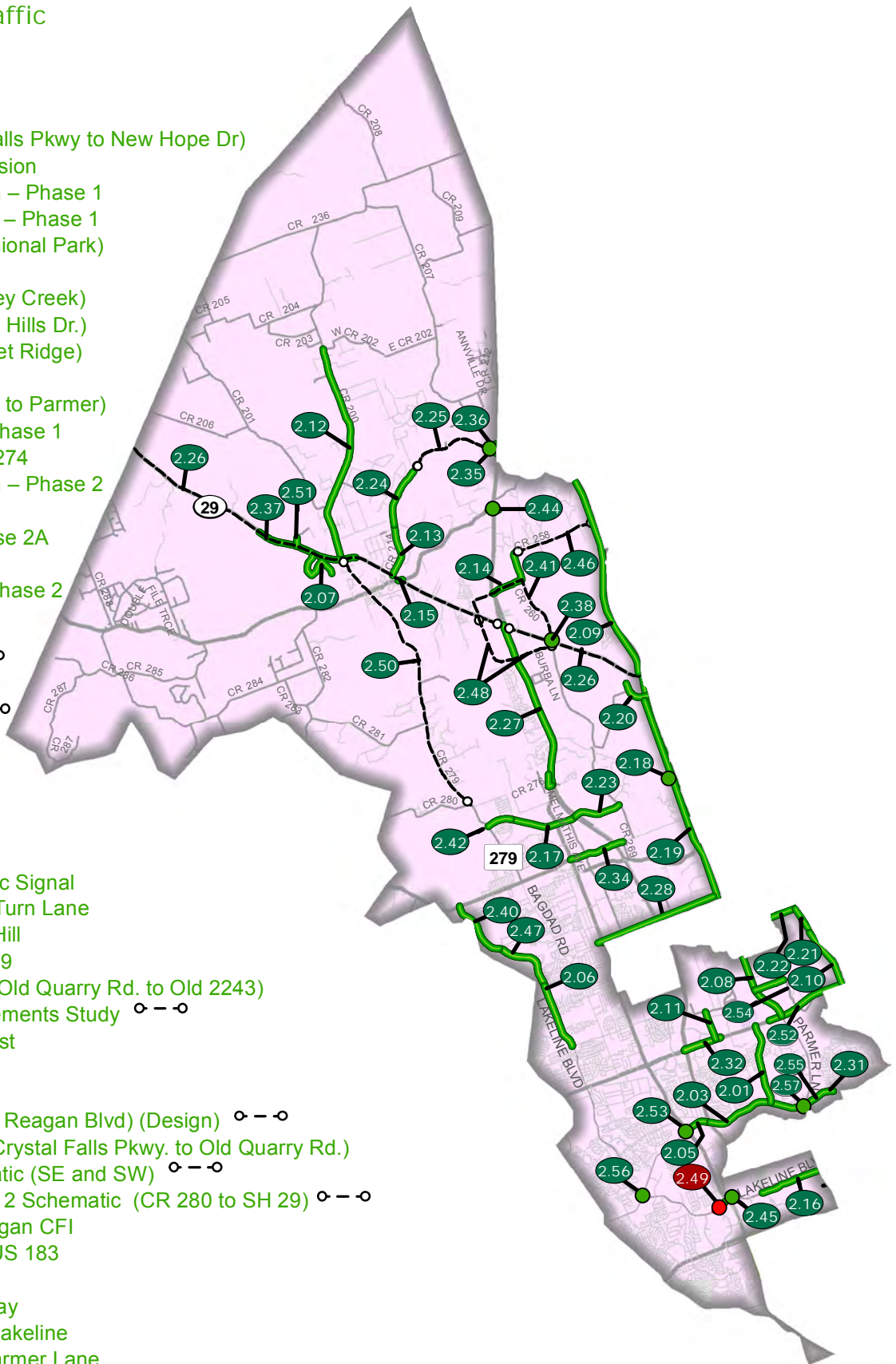

2013 ROAD BOND PROGRAM PROJECTS

PRECINCT 2 - COMMISSIONER LONG

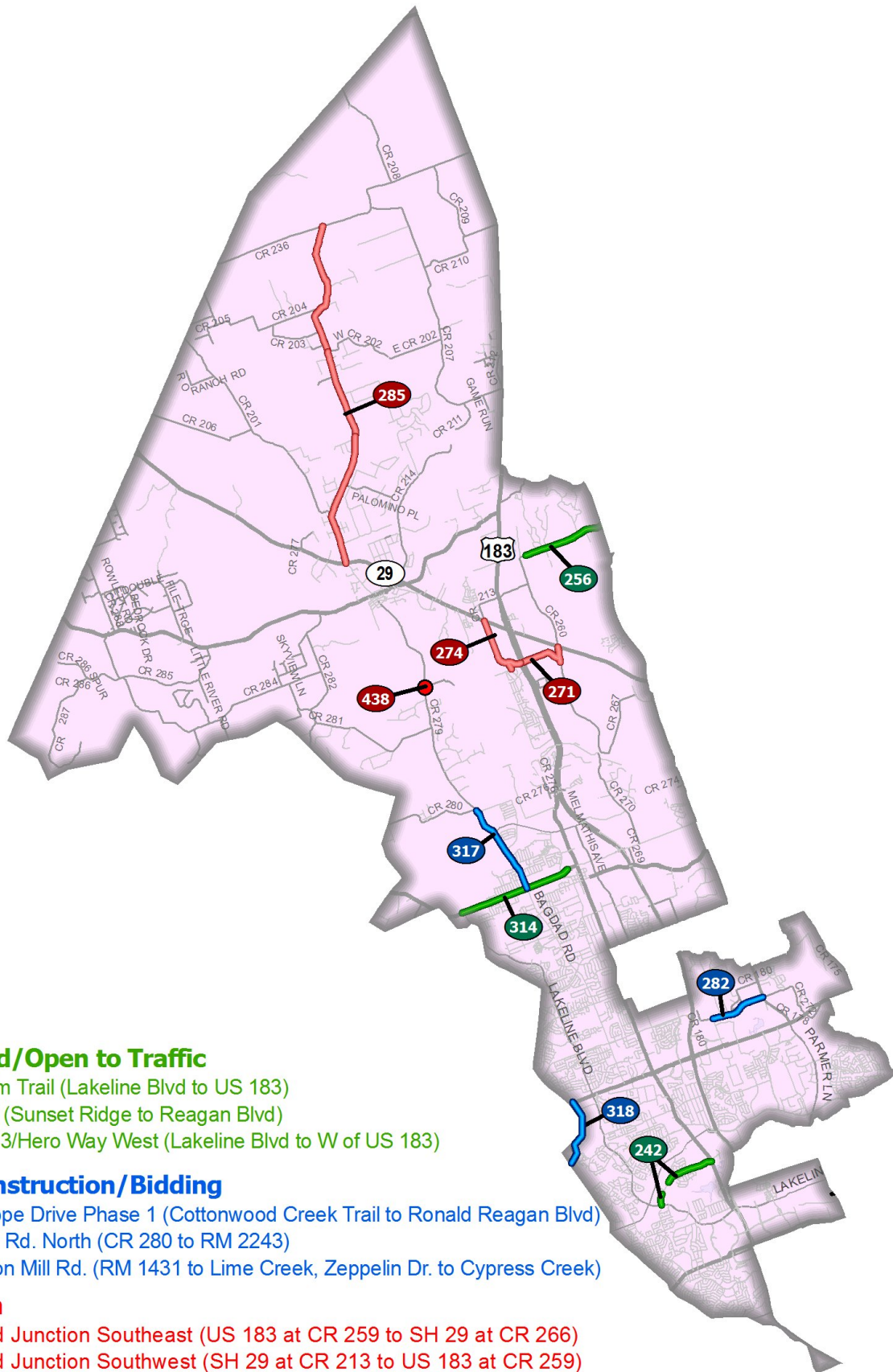

Completed/Open to Traffic

- 242 Little Elm Trail (Lakeline Blvd to US 183)
- 256 CR 258 (Sunset Ridge to Reagan Blvd)
- 314 Old 2243/Hero Way West (Lakeline Blvd to W of US 183)

Under Construction/Bidding

- 282 New Hope Drive Phase 1 (Cottonwood Creek Trail to Ronald Reagan Blvd)
- 317 Bagdad Rd. North (CR 280 to RM 2243)
- 318 Anderson Mill Rd. (RM 1431 to Lime Creek, Zeppelin Dr. to Cypress Creek)

In Design

- 271 Seward Junction Southeast (US 183 at CR 259 to SH 29 at CR 266)
- 274 Seward Junction Southwest (SH 29 at CR 213 to US 183 at CR 259)
- 285 CR 200 - Preliminary Design (SH 29 to CR 236)
- 438 Bagdad Road at CR 278

CR 258 (Sunset Ridge to Ronald Reagan)
Project No. 1603-062

Original Contract Price = \$5,808,856.58

<u>Letting</u>	<u>Award</u>	<u>Notice To Proceed</u>	<u>Begin Work</u>	<u>Substantial Completion</u>	<u>Work Accepted</u>	<u>Total Bid Days</u>	<u>Days Added</u>	<u>Total Days</u>	
4/20/2016	5/10/2016	7/29/2016	8/8/2016	7/25/2017		360	4	364	
<u>Invoice Number</u>	<u>Beginning Date</u>	<u>Ending Date</u>	<u>Days Charged</u>	<u>Current Invoice</u>	<u>Invoice Total</u>	<u>Current Retainage</u>	<u>Total Retainage</u>	<u>% (\$ Used)</u>	<u>% Time Used</u>
1	7/1/2016	7/31/2016	0	\$204,692.63	\$204,692.63	\$22,743.63	\$22,743.63	4	0
2	8/8/2016	8/31/2016	24	\$647,625.15	\$852,317.78	\$71,958.35	\$94,701.98	16	7
3	9/1/2016	9/30/2016	30	\$768,046.95	\$1,620,364.73	\$85,338.55	\$180,040.53	30	15
4	10/1/2016	10/31/2016	31	\$523,476.94	\$2,143,841.67	\$58,164.10	\$238,204.63	39	23
5	11/1/2016	11/30/2016	30	\$98,689.54	\$2,242,531.21	\$10,965.50	\$249,170.13	41	32
6	12/1/2016	12/31/2016	31	\$38,127.37	\$2,280,658.58	\$4,236.38	\$253,406.51	42	40
7	1/1/2017	1/31/2017	31	\$636,301.80	\$2,916,960.38	\$70,700.20	\$324,106.71	53	49
8	2/1/2017	2/28/2017	28	\$395,763.89	\$3,312,724.27	\$43,973.76	\$368,080.47	61	56
9	3/1/2017	3/31/2017	31	\$456,281.18	\$3,769,005.45	\$50,697.91	\$418,778.38	69	65
10	4/1/2017	4/30/2017	30	\$317,257.62	\$4,086,263.07	\$35,250.85	\$454,029.23	75	73
11	5/1/2017	5/31/2017	31	\$325,276.60	\$4,411,539.67	\$36,141.84	\$490,171.07	81	82
12	6/1/2017	6/30/2017	30	\$382,942.21	\$4,794,481.88	\$42,549.14	\$532,720.21	88	90
13	7/1/2017	7/25/2017	25	\$732,546.03	\$5,527,027.91	-\$241,824.00	\$290,896.21	96	97
14	7/26/2017	8/31/2017	0	\$153,724.56	\$5,680,752.47	-\$174,962.49	\$115,933.72	95	97
15	9/1/2017	9/30/2017	0	\$1,997.73	\$5,682,750.20	\$40.77	\$115,974.49	95	97
16	10/1/2017	10/31/2017	0	\$33,430.15	\$5,716,180.35	\$682.25	\$116,656.74	96	97
17	11/1/2017	11/30/2017	0	\$1,011.36	\$5,717,191.71	\$20.64	\$116,677.38	96	97
18	12/1/2017	12/31/2017	0	\$493.92	\$5,717,685.63	\$9.93	\$116,687.31	96	97
19	1/1/2018	1/31/2018	0	\$31,113.85	\$5,748,799.48	\$634.98	\$117,322.29	97	97

2/2/2018 Comments - Punchlist items have been completed.

<u>Change Order Number</u>	<u>Approved</u>	<u>Cost This CO</u>	<u>Total COs</u>
01	10/4/2016	9,660.00	9,660.00

4B: Third Party Accommodation. Third Party Requested Work. This Change Order adds an encasement pipe crossing for a future waterline under CR 258 at Station 160+50. The installation of the additional encasement pipe was requested by the Property owner for future water service. The additional cost of the encasement pipe will be deducted from the Right of Way acquisition agreement with the property owner.

<u>Change Order Number</u>	<u>Approved</u>	<u>Cost This CO</u>	<u>Total COs</u>
02	1/31/2017	33,848.00	43,508.00

3B: County Convenience. Public relations improvement. 3F: County Convenience. Additional work desired by the County. This Change Order changes the hot mix pavement section on CR 258 from one 3" lift of Type C HMA PG 70-22 to one 2" lift of Type C HMA PG 64-22 and one 1.5" lift of Type D HMA PG 64-22 and deletes the one course surface treatment on Ronald Reagan.

<u>Change Order Number</u>	<u>Approved</u>	<u>Cost This CO</u>	<u>Total COs</u>
03	2/28/2017	38,765.00	82,273.00

2C: Differing Site Conditions (Unforeseeable). New development (conditions changing after PS&E completed). 4B: Third Party Accommodation. Third party requested work. This change order reflects multiple driveway changes including, extending a driveway culvert to accommodate a new driveway location, relocating a proposed driveway, extending a driveway culvert to save a heritage oak tree, adding a driveway to the project and shortening the guardrail at a proposed driveway location.

<u>Change Order Number</u>	<u>Approved</u>	<u>Cost This CO</u>	<u>Total COs</u>
04	3/21/2017	14,907.69	97,180.69

6C: Untimely ROW/Utilities Utilities Not Clear: This Change Order compensates the Contractor for additional costs to locate and avoid impacts to the AT&T line and to ensure uninterrupted service to adjacent properties. Utilities AT&T and PEC were scheduled to be clear by August 31, 2016, but were not clear until February 2017. The Contractor worked to avoid impacts to the existing AT&T line during the installation of the new City of Georgetown water line.

<u>Change Order Number</u>	<u>Approved</u>	<u>Cost This CO</u>	<u>Total COs</u>
05	3/21/2017	51,199.00	148,379.69

2J: Differing Site Conditions. (unforeseeable) Other. This change order revises various erosion control measures on the project, including the addition of soil retention blanket to the contract to prevent erosion and help to establish vegetation quicker on the slopes and in the ditches. 3H: County Convenience. Cost savings opportunity discovered during construction. This change order replaces the 12" Gabion mattresses with Flexamat. The use of this product was approved by the County Road and Bridge Department. The 3' x 3' gabions were deleted due to changes at the downstream end of Culvert #2.

<u>Change Order Number</u>	<u>Approved</u>	<u>Cost This CO</u>	<u>Total COs</u>
06	5/16/2017	23,780.00	172,159.69

1A: Design Error or Omission. Incorrect PS&E. This Change Order documents the quantity/cost overrun to existing bid Item 508 Constructing Detours. 2C: Differing Site Conditions. New development (conditions changing after PS&E). This change order also includes the deletion of existing bid items; Item 403 Temporary Shoring, Item 552 Wire Fencing and Gate because these items will not be used on the project and a reduction in quantity for Item 512 Port Concrete Traffic Barrier, Ty 1 and 2.

<u>Change Order Number</u>	<u>Approved</u>	<u>Cost This CO</u>	<u>Total COs</u>
07	6/6/2017	48,426.44	220,586.13

2F: Differing Site Conditions (unforeseeable). Site conditions altered by an act of nature. Ground water was encountered at the east end of the project while excavating to subgrade on the proposed eastbound half of the project. After several days of pumping, cutting trenches, excavating, and reworking subgrade to try and dry it out a French drain was installed to relieve the ground water that was causing the issues with the subgrade.

<u>Change Order Number</u>	<u>Approved</u>	<u>Cost This CO</u>	<u>Total COs</u>
08	11/7/2017	47,221.90	267,808.03

2E: Miscellaneous difference in site conditions (unforeseeable)(Item 9). This Change Order documents payment to the Contractor for various items of additional work that include adding pipe at a driveway. 2F: Differing Site Conditions. Site conditions altered by an act of nature. Repair of storm damage on the project. 6C: Untimely ROW/Utilities. Utilities not clear. Added monthly barricades. 3F: County Convenience. Additional work desired by the County. Removal of a sign on the right of way.

Adjusted Price = \$6,076,664.61

2006 ROAD BOND PROGRAM PROJECTS

PRECINCT 3 - COMMISSIONER COVEY

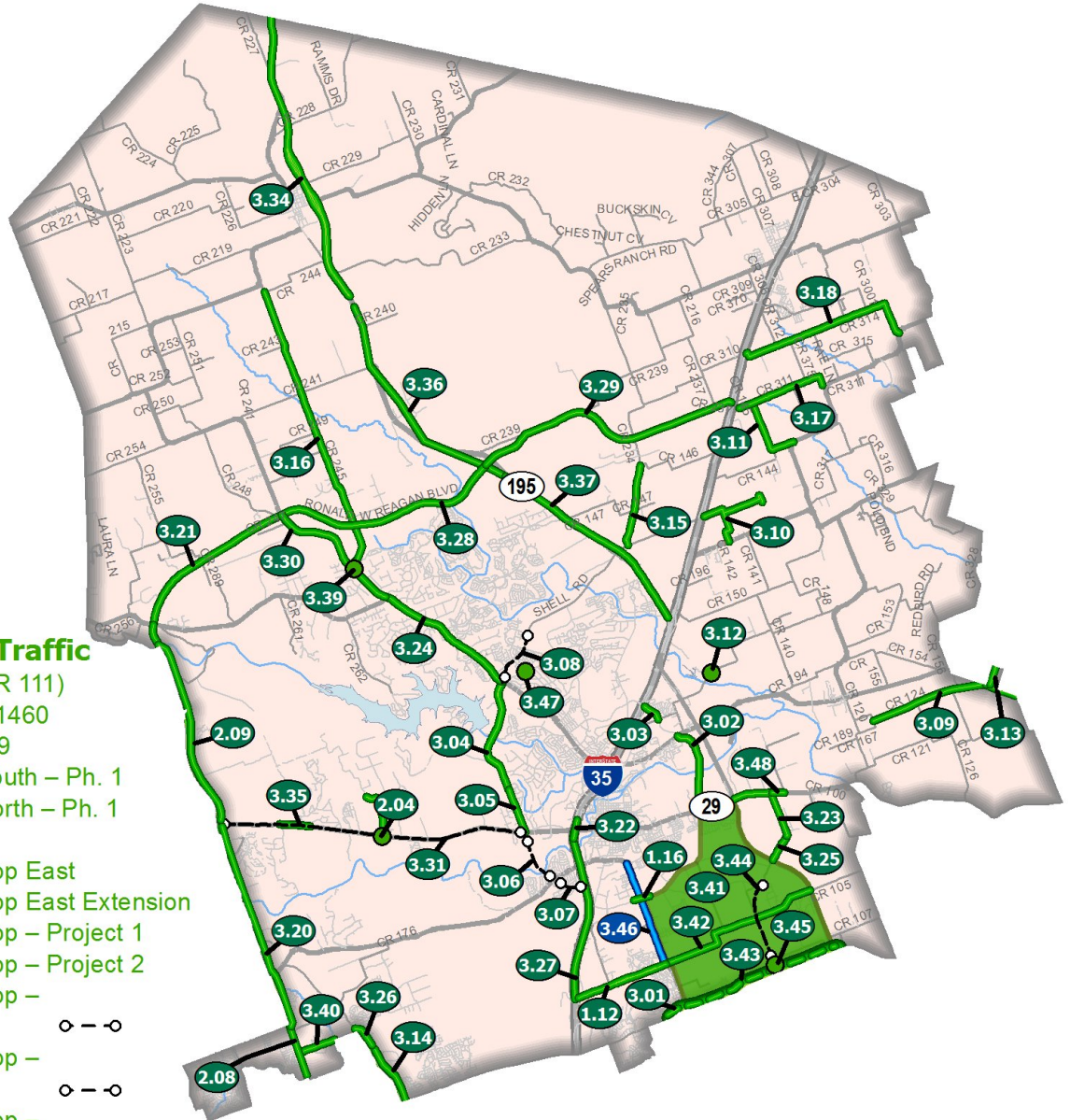

Completed/Open to Traffic

- 1.12 Westinghouse Rd. (CR 111)
- 1.16 SE Inner Loop at FM 1460
- 2.04 Cedar Hollow at SH 29
- 2.08 Ronald W. Reagan South – Ph. 1
- 2.09 Ronald W. Reagan North – Ph. 1
- 3.01 FM 1460 to CR 110
- 3.02 Georgetown Inner Loop East
- 3.03 Georgetown Inner Loop East Extension
- 3.04 Georgetown Inner Loop – Project 1
- 3.05 Georgetown Inner Loop – Project 2
- 3.06 Georgetown Inner Loop – Project 3 Study ○ - - ○
- 3.07 Georgetown Inner Loop – Project 4 Study ○ - - ○
- 3.08 Georgetown Inner Loop – Project 5 Study ○ - - ○
- 3.09 CR 124
- 3.10 CR 142
- 3.11 CR 145
- 3.12 CR 152 Bridge Replacement
- 3.13 CR 157
- 3.14 CR 175
- 3.15 CR 234
- 3.16 CR 245
- 3.17 CR 311
- 3.18 CR 314
- 3.20 Ronald W. Reagan South - Phase 2
- 3.21 Ronald W. Reagan North - Phase 2
- 3.22 IH-35 at SH 29 Turnarounds (PTF)
- 3.48 SH 29 Widening - 12" Water Main Relocation
- 3.23 SH 29/CR 104 – Phase 1
- 3.24 Williams Drive (RM 2338)
- 3.25 CR 104 – Phase 2
- 3.26 CR 175 Extension - Phase 2A
- 3.27 IH 35 Northbound Frontage Rd. and Ramps

- 3.28 Ronald W. Reagan North - Phase 3
- 3.29 Ronald W. Reagan North - Phase 4
- 3.30 RM 2338 (PTF)
- 3.31 SH 29 Improvements Study & Schematic ○ - - ○
- 3.34 SH 195 Project 1
- 3.35 SH 29 at Park Place Dr. & Jack Nicklaus Blvd.
- 3.36 SH 195 Project 2
- 3.37 SH 195 Project 3
- 3.39 CR 245 Realignment
- 3.40 CR 179
- 3.41 CR 110 / Arterial A Study (design)
- 3.42 CR 111 / CR 105 Westinghouse Rd. (FM 1460 to SH 130) (design)
- 3.43 University Blvd. (Chandler Rd) Expansion (Design)
- 3.44 CR 110 North ○ - - ○ (North of CR 107 to North of Sam Houston) (Design)
- 3.45 CR 110 Middle (North of Limmer Loop to CR 107)
- 3.47 Madrid Drive Extension

Under Construction/Bidding

- 3.46 FM 1460 North

2013 ROAD BOND PROGRAM PROJECTS

PRECINCT 3 - COMMISSIONER COVEY

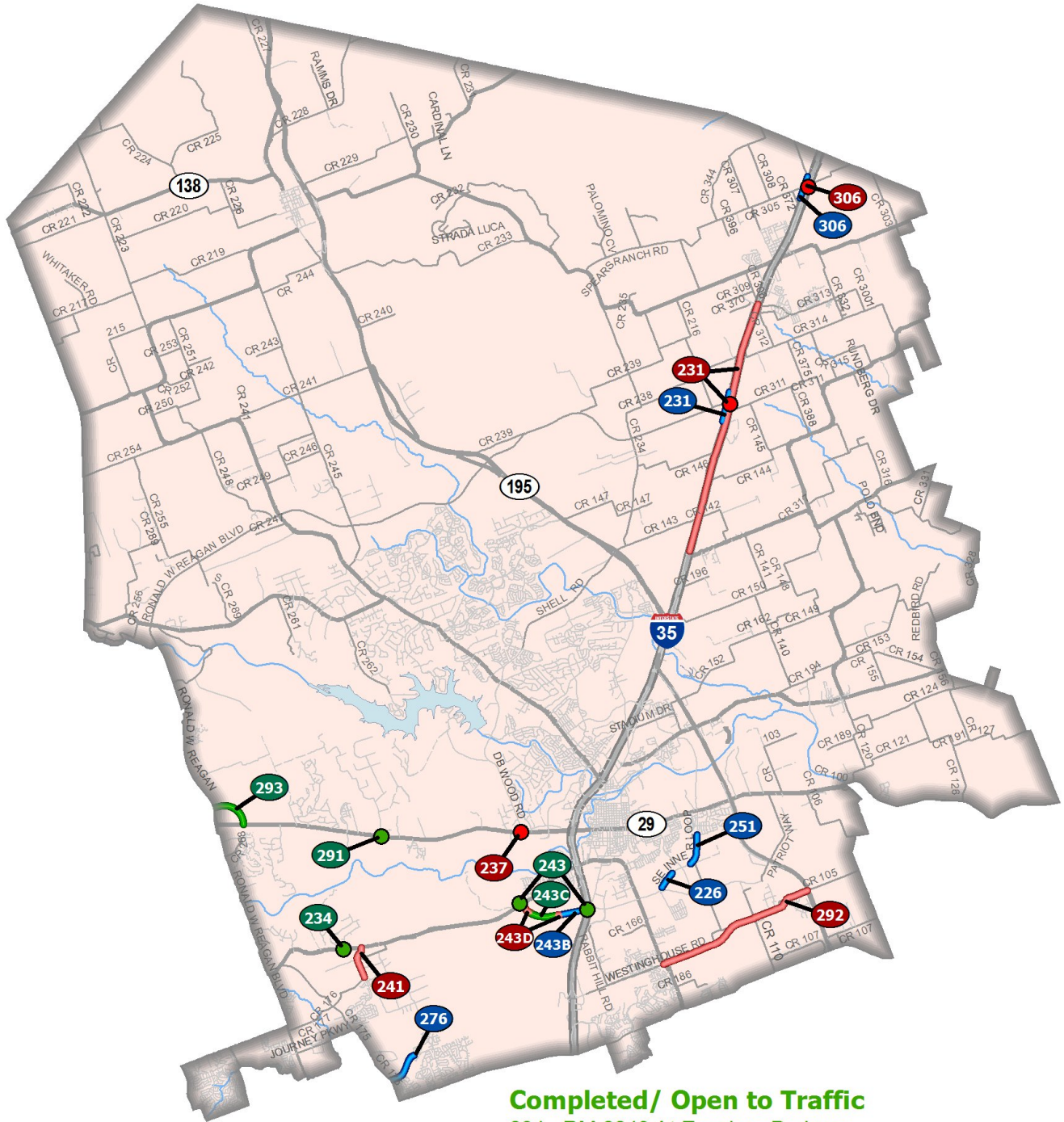

Under Construction/Bidding

- 226 Inner Loop Safety Improvements (Rockride Lane to Wilco Way)
- 231 Relocation of 48" Williamson County Regional Raw Waterline - Line B
- 243b Southwest Bypass Segment 1
- 251 Inner Loop Safety Improvements (Belmont Drive to Rockride Lane)
- 276 Arterial H Extension Phase 1 (CR 175 to Massey Way)
- 306 Relocation of 48" Williamson County Regional Raw Waterline - Line A

Completed/ Open to Traffic

- 234 RM 2243 At Escalera Parkway
- 243 Southwest Bypass Driveways
- 243c Southwest Bypass Access Route
- 291 SH 29 At Cedar Hollow
- 293 Kauffman Loop Phase 1 (NE quadrant of Reagan at SH 29)

In Design

- 231 Ronald Reagan at IH 35 (Bridge Replacement)
- 231 IH 35 Ramp Reversal and Frontage Road Conversion (FM 972 to CR 312)
- 237 DB Wood At SH 29
- 241 CR 176 at RM 2243 (Safety Improvements)
- 243d Southwest Bypass Segment 2
- 292 CR 111 / CR 105 Westinghouse Rd.(FM 1460 to SH 130)
- 306 CR 305 At IH 35 - Design (Bridge Replacement)



Arterial H
 (Sam Bass Rd to existing Arterial H)

Project Length: .83 Miles
 Roadway Classification: Minor Arterial

Project Schedule: June 2017 - March 2018
 Estimated Construction Cost: \$3.4 Million



JANUARY 2018 IN REVIEW

01/05/2018: Patin Construction finished processing the final course of flexible base from existing Arterial H (east end) to just west of Culvert A. Curb and gutter was placed from west of Culvert A to the Pedestrian Culvert along the proposed westbound lane.

01/12/2018: Curb and gutter was placed along the Pedestrian Culvert. The water line valves were adjusted behind the curb between Culvert A and the east end of the project. Grading and forming for the valley gutter at Tavarez has begun.

01/19/2018: Topsoil was graded behind the curb from CR 175 up to Culvert A. The curb from Culvert A to the east end of the project was backfilled. Concrete was placed for the valley gutter at Tavarez and the Shared Use Path. Inlet lids for curb inlets 11 and 13 were formed.

01/26/2018: Concrete for the Shared Use Path was completed. The water line valve aprons were completed. The final curb was slipformed across from Culvert B and at the ribbon curb on the transition at the east end.



Design Engineer: Randall Jones
 Contractor: Patin Construction
 Construction Observation:
 Steven Shull, HNTB

Williamson County
 Road Bond Program



**Arterial H Phase 1 (Sam Bass Rd to existing Arterial H)
Project No. 1603-064**

Original Contract Price = \$3,210,934.80

<u>Letting</u>	<u>Award</u>	<u>Notice To Proceed</u>	<u>Begin Work</u>	<u>Substantial Completion</u>	<u>Work Accepted</u>	<u>Total Bid Days</u>	<u>Days Added</u>	<u>Total Days</u>
4/20/2016	5/16/2016	2/17/2017 (Limited) 5/26/2017	6/5/2017			150	120	270

<u>Invoice Number</u>	<u>Beginning Date</u>	<u>Ending Date</u>	<u>Days Charged</u>	<u>Current Invoice</u>	<u>Invoice Total</u>	<u>Current Retainage</u>	<u>Total Retainage</u>	<u>% (\$ Used)</u>	<u>% Time Used</u>
1	6/1/2016	6/30/2016	0	\$134,198.10	\$134,198.10	\$14,910.90	\$14,910.90	4	0
2	7/1/2016	7/31/2016	0	\$182,746.89	\$316,944.99	\$20,305.21	\$35,216.11	10	0
3	8/1/2016	8/31/2016	0	\$93,893.40	\$410,838.39	\$10,432.60	\$45,648.71	13	0
4	9/1/2016	9/30/2016	0	\$206,817.21	\$617,655.60	\$22,979.69	\$68,628.40	20	0
5	6/4/2017	6/30/2017	27	\$47,340.00	\$664,995.60	\$5,260.00	\$73,888.40	22	10
6	7/1/2017	8/31/2017	62	\$587,022.75	\$1,252,018.35	\$65,224.75	\$139,113.15	41	33
7	9/1/2017	9/30/2017	30	\$320,055.75	\$1,572,074.10	\$35,561.75	\$174,674.90	51	44
8	10/1/2017	10/31/2017	31	\$158,107.95	\$1,730,182.05	\$17,567.55	\$192,242.45	57	56
9	11/1/2017	11/30/2017	30	\$140,265.17	\$1,870,447.22	\$15,585.02	\$207,827.47	61	67
10	12/1/2017	12/31/2017	31	\$186,341.94	\$2,056,789.16	\$20,704.66	\$228,532.13	67	78
11	1/1/2018	1/31/2018	31	\$412,576.91	\$2,469,366.07	\$274,374.01	\$502,906.14	87	90

<u>Change Order Number</u>	<u>Approved</u>	<u>Cost This CO</u>	<u>Total COs</u>
01	8/29/2017	132,771.00	132,771.00

4C: Third Party Accommodation. Compliance requirements of new laws and/or policies (impacting third party). Project delayed, due to TCEQ approval process for Water Quality pond design changes. 2C: Differing Site Conditions (unforeseeable). New development (conditions changing after PS&E completed). Design changes were necessary, due to unknown elevation of existing water table

<u>Change Order Number</u>	<u>Approved</u>	<u>Cost This CO</u>	<u>Total COs</u>
02	1/23/2018	58,143.87	190,914.87

3E. County Convenience. Reduction of future maintenance. This change order adds soil retention blanket to the contract to prevent erosion and to establish vegetation on the slopes and along the roadway. 1B. Design Error or Omission. This change order also adds items to the contract for work shown in the plans but not included in the summary of items and quantities. 2E: Differing Site Conditions. (unforeseeable) Miscellaneous difference in site conditions (unforeseeable)(Item 9). This Change Order deletes lime treated subgrade items due to the quality of the material encountered at subgrade elevation.

Adjusted Price = \$3,401,849.67

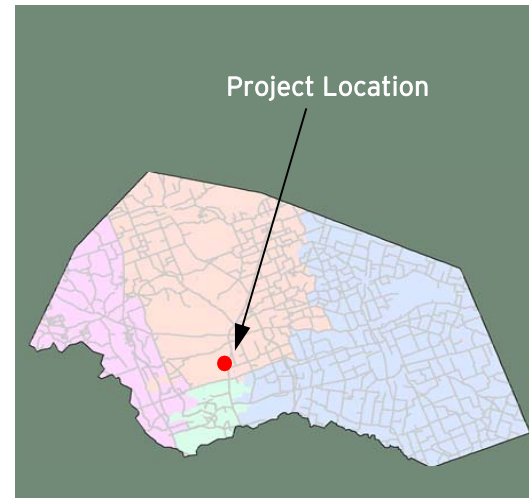

Southwest Bypass Segment One
 (IH 35 Southbound to .5 miles west)

Project Length: .5 Mile
 Roadway Classification: Collector

Project Schedule: August 2017 - July 2018
 Estimated Construction Cost: \$5.7 Million



JANUARY 2018 IN REVIEW

01/05/2018: Jordan Foster continued to place embankment for the pond and stockpile material for the roadway west of the railroad tracks. The steel cages for Bent 6 and 7 spread footings were set, graded, and the concrete was placed for these footings.

01/12/2018: The pond area continued to be graded and compacted. The steel cage for Bent 5 spread footing was set, graded, and the concrete was placed for this footing. The footings are being graded for Bent 3 and 4 spread footings. The headwalls at Culvert 2 were excavated.

01/19/2018: The headwall footing and the 36" safety end treatment at Culvert 1 were excavated, graded and concrete placed.

01/26/2018: The footings for Abutment 1 and Bent 2 were excavated and graded. Subcontractor Woolery Fence completed the permanent fencing around Karst features 1, 2, and 3. Subcontractor TX Highway Walls excavated, placed the leveling pad for RW 1 from the east end to Culvert 1, and started setting panels.



Design Engineer: HDR Engineering
 Contractor: Jordan Foster Construction
 Construction Observation: Steven Shull, HNTB

Williamson County
 Road Bond Program



**Southwest Bypass Segment 1 (southbound IH 35 to .5 miles west)
2017-0065-CIP**

Original Contract Price = \$5,599,200.86

<u>Letting</u>	<u>Award</u>	<u>Notice To Proceed</u>	<u>Begin Work</u>	<u>Substantial Completion</u>	<u>Work Accepted</u>	<u>Total Bid Days</u>	<u>Days Added</u>	<u>Total Days</u>
6/27/2017	7/26/2017	8/21/2017	8/21/2017			337	0	337

<u>Invoice Number</u>	<u>Beginning Date</u>	<u>Ending Date</u>	<u>Days Charged</u>	<u>Current Invoice</u>	<u>Invoice Total</u>	<u>Current Retainage</u>	<u>Total Retainage</u>	<u>% (\$ Used)</u>	<u>% Time Used</u>
1	8/21/2017	9/30/2017	41	\$481,587.30	\$481,587.30	\$25,346.70	\$25,346.70	9	12
2	10/1/2017	10/31/2017	31	\$939,731.93	\$1,421,319.23	\$24,112.88	\$49,459.58	26	21
3	11/1/2017	11/30/2017	30	\$165,940.58	\$1,587,259.81	\$8,733.71	\$58,193.29	29	30
4	12/1/2017	12/31/2017	31	\$175,883.70	\$1,763,143.51	\$9,257.04	\$67,450.33	32	39
5	1/1/2018	1/31/2018	31	\$568,442.13	\$2,331,585.64	\$97,363.96	\$164,814.29	44	49

<u>Change Order Number</u>	<u>Approved</u>	<u>Cost This CO</u>	<u>Total COs</u>
01	12/12/2017	114,077.58	114,077.58

3F: County Convenience. Additional work desired by the County. This Change Order adds a stub-out of 380 feet to the east end of the Southwest Bypass for future connection to the Southeast Inner Loop at the IH-35 frontage road. All related items and quantities will be overruns or underruns of current Contract items.

Adjusted Price = \$5,713,278.44

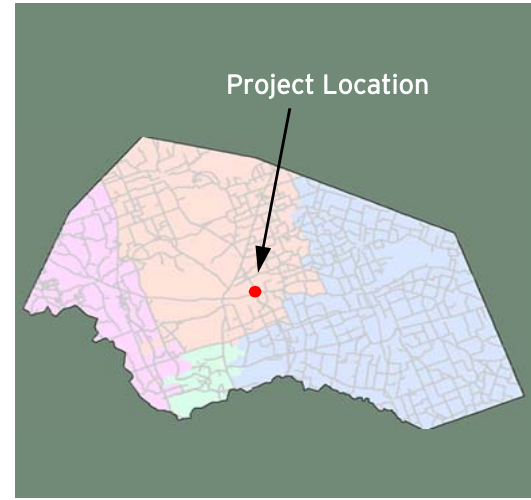

Inner Loop Improvements
 (WilCo Way to Belmont Drive)

Project Length: 4.4 Miles
 Roadway Classification: Urban Arterial

Project Schedule: September 2017 - June 2018
 Estimated Construction Cost: \$5.3 Million



JANUARY 2018 IN REVIEW

01/05/2018: Chasco Contractors continued prepping flexible base on the east side of Inner Loop for asphalt placement. The relocation of the Contractor's staging area began in preparation to grade side slopes for topsoil.

01/12/2018: Sidewalk excavation began on the west side of Inner Loop. Concrete for the footing and sidewalk culvert boxes was poured. Subcontractor Wheeler placed asphalt for pavement repairs and the sub surface course between Rockride and Belmont.

01/19/2018: Subcontractor DIJ striped and switched traffic to Phase 2. The headwalls and deck for the sidewalk culvert boxes were formed west of Culvert 1. The 5'x2' box culvert installation for Culvert 2 resumed.

01/26/2018: The upstream headwall footing was formed for Culvert #2. Riprap was formed and poured north and south of Culvert 2 and the 5'x2' box culvert installation was completed for Culvert 2. The northern County Maintenance Facility driveway was closed and excavated. The ditch and roadway along the southbound lanes were excavated between Culvert 1 and the north end of the project. A 24" RCP was installed for two Maintenance Facility driveways.



Design Engineer: Rodriguez
 Transportation Group / Bridgefarmer
 Contractor: Chasco Contractors
 Construction Observation:
 Seth Turvey, HNTB

Williamson County
 Road Bond Program



**Inner Loop Improvements (WilCo Way to Belmont Dr.)
Project No. 1706-168**

Original Contract Price = \$5,352,969.00

<u>Letting</u>	<u>Award</u>	<u>Notice To Proceed</u>	<u>Begin Work</u>	<u>Substantial Completion</u>	<u>Work Accepted</u>	<u>Total Bid Days</u>	<u>Days Added</u>	<u>Total Days</u>	
8/9/2017	8/30/2017	9/18/2017	9/28/2017			300	0	300	
<u>Invoice Number</u>	<u>Beginning Date</u>	<u>Ending Date</u>	<u>Days Charged</u>	<u>Current Invoice</u>	<u>Invoice Total</u>	<u>Current Retainage</u>	<u>Total Retainage</u>	<u>% (\$ Used)</u>	<u>% Time Used</u>
1	9/28/2017	10/31/2017	34	\$324,036.00	\$324,036.00	\$36,004.00	\$36,004.00	6.7	11
2	11/1/2017	11/30/2017	30	\$429,129.00	\$753,165.00	\$47,681.00	\$83,685.00	15.6	21
3	12/1/2017	1/31/2018	62	\$460,398.44	\$1,213,563.44	\$51,155.38	\$134,840.38	25.2	42

<u>Change Order Number</u>	<u>Approved</u>	<u>Cost This CO</u>	<u>Total COs</u>
01	12/5/2017	6,050.40	6,050.40

3E: County Convenience. Reduction of future maintenance. This Change Order revises the hot mix asphalt (HMAC) pavement section on the Inner Loop from one 2" lift of Type C HMAC to one 2" lift of Type D HMAC.

Adjusted Price = \$5,353,017.00

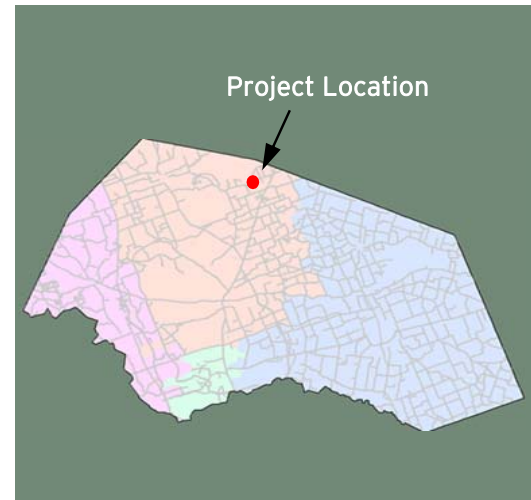

Williamson County Regional Raw Water Line Relocation
 (Ronald Reagan Blvd at IH 35 and CR 305 at IH 35)

Project Length: .2 Miles
 Roadway Classification: Water Line Relocation

Project Schedule: January 2018 - March 2018
 Estimated Construction Cost: \$1.2 Million



JANUARY 2018 IN REVIEW

01/05/2018: The manuals and Notice of Award were issued to the Contractor, Santa Clara Construction, on 12/15/17.

01/12/2018: A preconstruction meeting was held on 1/12/18. Notice to Proceed was issued on 1/12/2018 with time charges beginning on 1/22/2018.

01/26/2018: Advanced warning signs and silt fence was installed at both sites. Water barriers were installed at the Reagan intersection. Santa Clara Construction pot-holed existing pipe to verify type of pipe.



Design Engineer: Cobb Fendley
 Contractor: Santa Clara Construction
 Construction Observation:
 Ryan River, HNTB

Williamson County
 Road Bond Program

**Williamson County Regional Raw Water Line
Project No. 1708-187**

Original Contract Price = \$1,232,539.10

<u>Letting</u>	<u>Award</u>	<u>Notice To Proceed</u>	<u>Begin Work</u>	<u>Substantial Completion</u>	<u>Work Accepted</u>	<u>Total Bid Days</u>	<u>Days Added</u>	<u>Total Days</u>	
10/3/2017	11/14/2017	1/12/2018	1/22/2018			60	0	60	
<u>Invoice Number</u>	<u>Beginning Date</u>	<u>Ending Date</u>	<u>Days Charged</u>	<u>Current Invoice</u>	<u>Invoice Total</u>	<u>Current Retainage</u>	<u>Total Retainage</u>	<u>% (\$ Used)</u>	<u>% Time Used</u>
1	1/22/2018	2/6/2018	16	\$145,027.80	\$145,027.80	\$16,114.20	\$16,114.20	13.1	27
2/2/2018	Comments - Notice to Proceed was issued 1/12/2018 with time charges beginning 1/22/2018.								
						Adjusted Price = \$1,232,587.10			

2006 ROAD BOND PROGRAM PROJECTS PRECINCT 4 - COMMISSIONER MADSEN

In Design

4.35 FM 1660 (PTF)

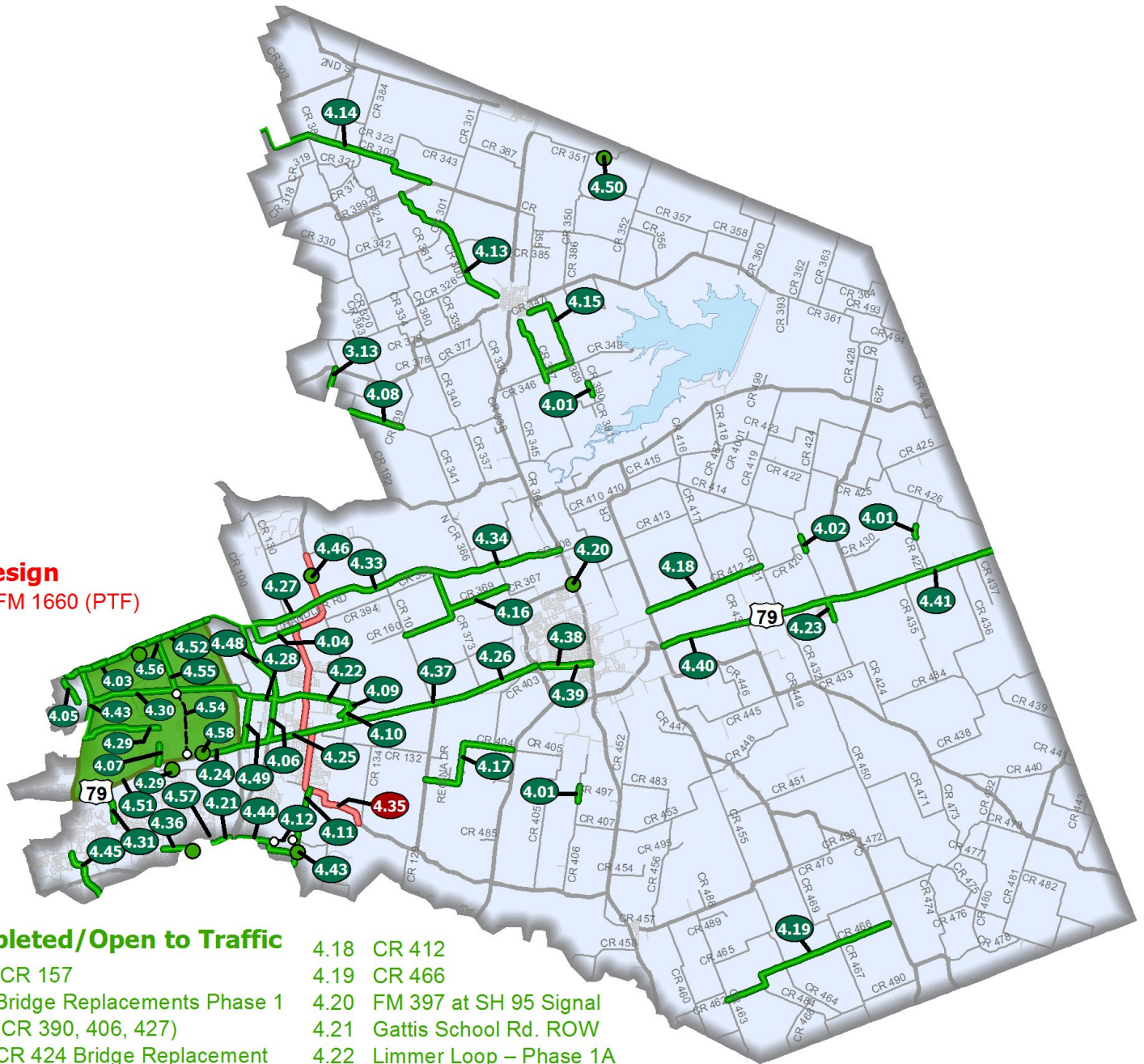

Completed/Open to Traffic

- | | | |
|---|---------------------------------------|---|
| 3.13 CR 157 | 4.18 CR 412 | 4.43 FM 1460 Section 2 |
| 4.01 Bridge Replacements Phase 1 (CR 390, 406, 427) | 4.19 CR 466 | 4.44 CR 138 |
| 4.02 CR 424 Bridge Replacement | 4.20 FM 397 at SH 95 Signal | 4.45 CR 170 |
| 4.03 Chandler Rd. - Phase 1 | 4.21 Gattis School Rd. ROW | 4.46 FM 1660 at Landfill Rd. (CR 128) |
| 4.04 CR 100 | 4.22 Limmer Loop - Phase 1A | 4.48 CR 119 |
| 4.05 CR 112 - Phase 1 | 4.23 Thrall School Zone | 4.49 CR 108 |
| 4.06 CR 119 | 4.24 US 79 - Section 1 | 4.50 CR 351 at Donahoe Creek |
| 4.07 CR 122 at US 79 | 4.25 US 79 - Section 2 | 4.51 CR 110/ Arterial A Study Area |
| 4.08 CR 124 | 4.26 US 79 - Section 3A | 4.52 University Blvd. (Chandler Rd.) Expansion |
| 4.09 CR 132 | 4.27 Chandler Rd. - Phase 2 | 4.54 CR 110 South - (Design) (US 79 to Limmer Lp) |
| 4.10 CR 136 | 4.28 Limmer Loop - Phase 1B | 4.55 CR 110 Middle (North of Limmer Loop to CR 107) |
| 4.11 CR 137 | 4.29 CR 113 / Old Settlers Blvd. | 4.56 CR 110 at University Blvd. (Signal) |
| 4.12 CR 138 & CR 139 Alignment Study | 4.30 Limmer Loop - Phase 1C | 4.57 Gattis School Rd. at Winterfield Dr. (Signal) |
| 4.13 CR 300 & CR 301 | 4.31 Kenney Fort Boulevard - Phase 1 | 4.58 Tradesman Park Crossing |
| 4.14 CR 302 | 4.33 Chandler Rd. - Phase 3A | |
| 4.15 CR 347 & CR 348 | 4.34 Chandler Rd. - Phase 3B | |
| 4.16 CR 368 & CR 369 (CR 101 to CR 366) | 4.36 Gattis School Road | |
| 4.17 CR 404 | 4.37 US 79 - Section 3 (PTF) | |
| | 4.38 2nd Street Improvements | |
| | 4.39 2nd Street Drainage Improvements | |
| | 4.40 US 79 Section 5A (PTF) | |
| | 4.41 US 79 Section 5B (PTF) | |

2013 ROAD BOND PROGRAM PROJECTS PRECINCT 4 - COMMISSIONER MADSEN

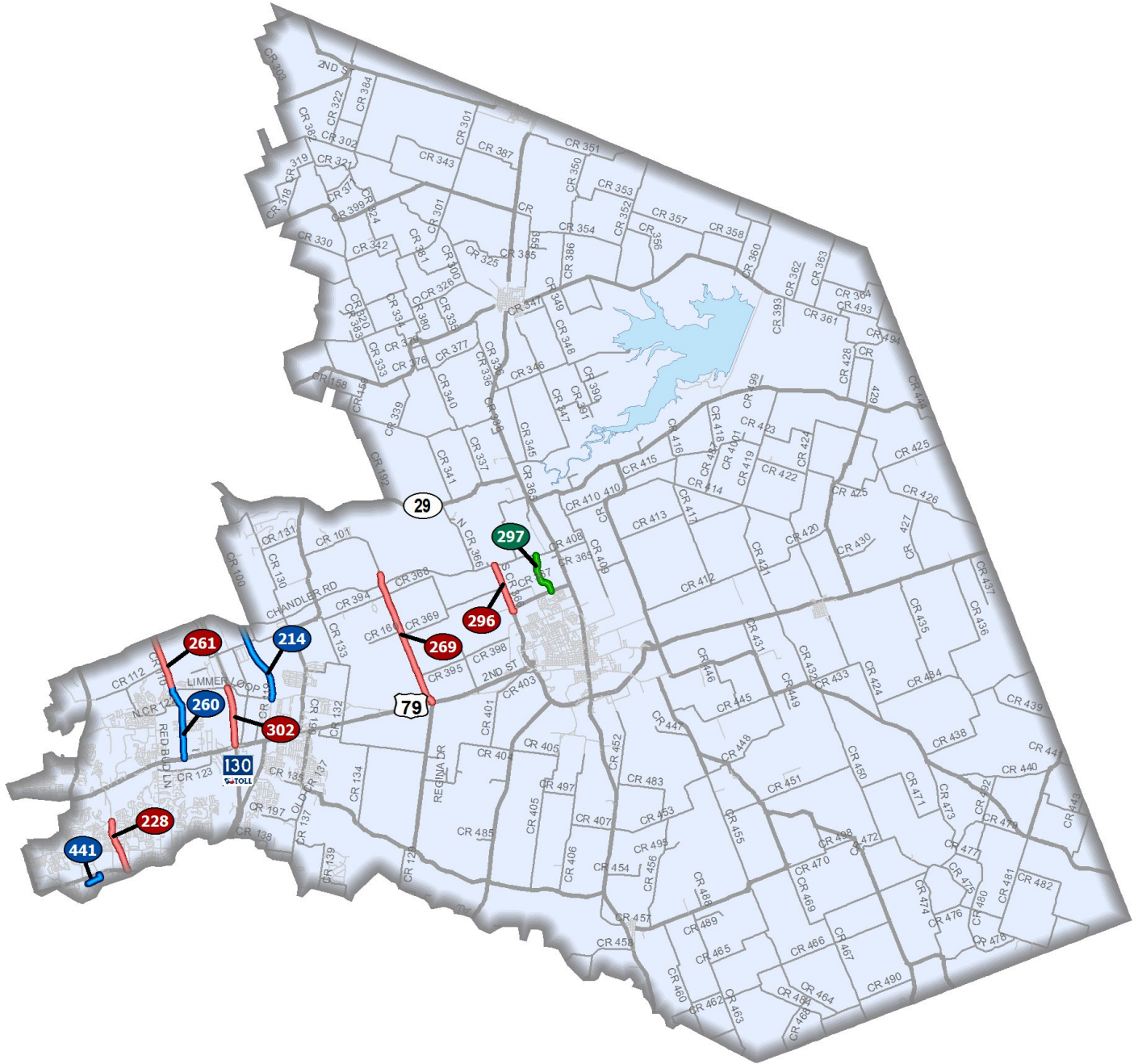

Completed/Open to Traffic

297 Bill Pickett Trail (Carlos Parker Blvd to Chandler Road)

Under Construction/Bidding

214 CR 119

260 CR 110 South (US 79 to Limmer Loop)

441 Roundville Lane (A.W. Grimes Blvd. to EBFR of SH 45)

In Design

228 Kenney Fort Blvd. Ph. 1 (Forest Creek Blvd. to Gattis School Rd.)

261 CR 110 Middle (N Limmer Loop to CR 107)

269 CR 101 (US 79 to North of Chandler Rd.)

296 CR 366 Widening - Chandler Rd. to Carlos G. Parker Blvd.

302 SH 130 Frontage Roads Phase 3 (SBFR US 79 to Limmer Loop)

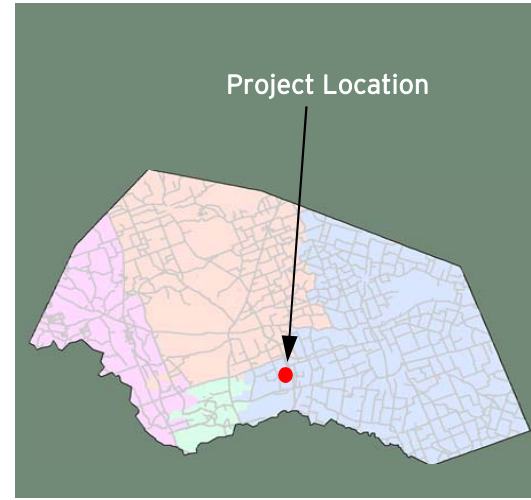

County Road 110 South
 (US 79 to Limmer Loop)

Project Length: 2.25 Miles
 Roadway Classification: Minor Urban Arterial

Project Schedule: January 2017-June 2018
 Estimated Construction Cost: \$11.2 Million



JANUARY 2018 IN REVIEW

01/05/2018: Chasco Constructors continued placing concrete for riprap in the east ditch between Salvador Lane and Limmer Loop. Topsoil was regraded from County Road 122 to Salvador Lane.

01/12/2018: The concrete riprap was completed in the east ditch between Salvador Lane and Limmer Loop. Subcontractor APAC-Wheeler placed asphalt from US 79 to the McNutt Creek bridge. Subcontractor Roadway Specialties, Inc. placed seeding and soil retention blankets in the ditches between CR 122 and Salvador Lane.

01/19/2018: Subcontractor RSI installed metal beam guard fence south of the bridge on the east side. Concrete was formed and poured for the mow strip south of the bridge. Parma Lane at CR 110 was closed the 18" RCP was installed along with inlets.

01/26/2018: Concrete was formed and poured for the sidewalk and grout for the guardrail leave outs on the south side of the McNutt Creek bridge. Flexible base was placed and formed at the Parma intersection.



Design Engineer: Dannenbaum
 Contractor: Chasco Constructors
 Construction Observation:
 David Boone, HNTB

Williamson County
 Road Bond Program



**CR 110 South (US 79 to Limmer Loop)
Project No. 1604-075**

Original Contract Price = \$11,224,589.02

<u>Letting</u>	<u>Award</u>	<u>Notice To Proceed</u>	<u>Begin Work</u>	<u>Substantial Completion</u>	<u>Work Accepted</u>	<u>Total Bid Days</u>	<u>Days Added</u>	<u>Total Days</u>	
9/27/2016	10/17/2016	1/3/2017	1/13/2017			510	0	510	
<u>Invoice Number</u>	<u>Beginning Date</u>	<u>Ending Date</u>	<u>Days Charged</u>	<u>Current Invoice</u>	<u>Invoice Total</u>	<u>Current Retainage</u>	<u>Total Retainage</u>	<u>% (\$ Used)</u>	<u>% Time Used</u>
1	1/13/2017	3/31/2017	78	\$1,644,069.60	\$1,644,069.60	\$182,674.40	\$182,674.40	16	15
2	4/1/2017	4/30/2017	30	\$393,511.50	\$2,037,581.10	\$43,723.50	\$226,397.90	20	21
3	5/1/2017	5/31/2017	31	\$582,730.20	\$2,620,311.30	\$64,747.80	\$291,145.70	26	27
4	6/1/2017	6/30/2017	30	\$630,479.66	\$3,250,790.96	\$70,053.30	\$361,199.00	32	33
5	7/1/2017	7/31/2017	31	\$803,057.63	\$4,053,848.59	\$89,228.62	\$450,427.62	40	39
6	8/1/2017	8/31/2017	31	\$1,287,965.24	\$5,341,813.83	\$143,107.25	\$593,534.87	53	45
7	9/1/2017	9/30/2017	30	\$469,097.52	\$5,810,911.35	\$52,121.95	\$645,656.82	57	51
8	10/1/2017	10/31/2017	31	\$875,490.26	\$6,686,401.61	\$97,276.69	\$742,933.51	66	57
9	11/1/2017	11/30/2017	30	\$435,997.94	\$7,122,399.55	\$48,444.22	\$791,377.73	70	63
10	12/1/2017	12/31/2017	31	\$176,721.48	\$7,299,121.03	\$19,635.72	\$811,013.45	72	69
11	1/1/2018	1/31/2018	31	\$408,025.00	\$7,707,146.03	\$45,336.11	\$856,349.56	76	75

<u>Change Order Number</u>	<u>Approved</u>	<u>Cost This CO</u>	<u>Total COs</u>
01	6/15/2017	-5,837.31	-5,837.31

1A: Design Error or Omission. Incorrect PS&E. The proposed flow of water from Box Culvert 6 went through the middle of a downstream property; therefore, a redesign and relocation of Culvert 6 was necessary. 4B: Third Party Accommodation. Third party requested work. The property owner at the downstream end of the proposed culvert requested that the water flow around his property limits, as it does in the current conditions. 2C: Differing Site Conditions. New development (conditions changing after PS&E completed). The Mozart Street connection to CR 110 South was permitted and built after the completion of the CR 110 South roadway plans and plan revisions were required to tie-in properly

<u>Change Order Number</u>	<u>Approved</u>	<u>Cost This CO</u>	<u>Total COs</u>
02	9/19/2017	2,840.00	-2,997.31

2E: Differing Site Conditions (unforeseeable). Miscellaneous difference in site conditions (unforeseeable) (Item 9). This Change Order substitutes a wingwall with a special drop inlet due to safety slope reasons. The proposed culvert upstream flowline was approximately 4' below ditch profile grades, which would have resulted in an extremely steep backslope at the end of the culvert. 4B: Third Party Accommodation. Third party requested work. This Change Order also addresses over-runs and under-runs for various waterline components and includes substituting the HDPE bore pipe for steel encasement pipe at the request of Seminole Pipeline.

<u>Change Order Number</u>	<u>Approved</u>	<u>Cost This CO</u>	<u>Total COs</u>
03	12/12/2017	31,812.74	28,815.43

3E: County Convenience. Reduction of future maintenance. This Change Order replaces surface hot mix Type C to Type D, supplements the Type 4 seeding mix with Type 11 (Bermuda), and adds additional concrete pipe and end treatment items at utility poles. 3H: County Convenience. Cost savings opportunity discovered during construction. This Change Order also substitutes single-slope portable concrete barrier with low profile concrete barrier (LPCB).

Adjusted Price = \$11,253,404.45

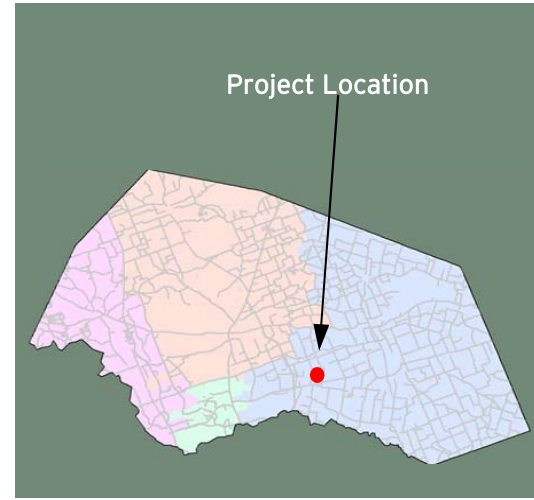

County Road 119
 (Limmer Loop to Chandler Rd)

Project Length: 2.35 Miles
 Roadway Classification: Suburban Collector

Project Schedule: December 2017-March 2019
 Estimated Construction Cost: \$6.6 Million



JANUARY 2018 IN REVIEW

01/12/2018: Joe Bland pot-holed for existing utility conflicts along the west side of CR 119 north of Limmer Loop. Excavation began on the proposed drainage easement on the East side on CR 119 north of Limmer Loop.

01/19/2018: Topsoil was stripped along the west side of CR 119 north of Limmer Loop. Excavation continued on the proposed drainage easement on the east side of CR 119 north of Limmer Loop.

01/26/2018: Topsoil continued to be stripped along the west side of CR 119 north of Limmer Loop. The excavation continued on the proposed drainage easements at culvert A & B on the east side of CR 119 north of Limmer Loop. Subcontractor Triple A Fence began the installation of new fence on the west side of Culvert B.



Design Engineer: Stantec Consulting
 Contractor: Joe Bland Construction
 Construction Observation:
 Seth Turvey, HNTB

Williamson County
 Road Bond Program

CR 119 (Limmer Loop to Chandler Rd)
Project No. 1708-186

Original Contract Price = \$6,640,302.71

<u>Letting</u>	<u>Award</u>	<u>Notice To Proceed</u>	<u>Begin Work</u>	<u>Substantial Completion</u>	<u>Work Accepted</u>	<u>Total Bid Days</u>	<u>Days Added</u>	<u>Total Days</u>	
10/25/2017	11/15/2017	12/8/2017	12/18/2017			450		450	
<u>Invoice Number</u>	<u>Beginning Date</u>	<u>Ending Date</u>	<u>Days Charged</u>	<u>Current Invoice</u>	<u>Invoice Total</u>	<u>Current Retainage</u>	<u>Total Retainage</u>	<u>% (\$)</u> <u>Used</u>	<u>% Time</u> <u>Used</u>
1	12/1/2017	12/31/2017	31	\$65,613.60	\$65,613.60	\$7,290.40	\$7,290.40	1	7
2	1/1/2018	1/31/2018	31	\$473,860.64	\$539,474.24	\$52,651.18	\$59,941.58	9	14
								Adjusted Price = \$6,640,302.71	

Commissioners Court - Regular Session

27.

Meeting Date: 02/27/2018

Pearson Ranch Road - Change Order No. 5

Submitted By: Dawn Haggard, Road Bond

Department: Road Bond

Agenda Category: Regular Agenda Items

Information

Agenda Item

Discuss, consider, and take appropriate action regarding Change Order No. 5 in the amount of -\$2,831.05 for Pearson Ranch Road, a Road Bond Project in Commissioner Pct. 1. Project: P221 Pearson Ranch Road. Funding Source: Road Bond

Background

This Change Order provides the final balancing for the overrun/underrun of Contract quantities for the items paid for by the City of Austin. Changes to the final quantities on the project were the result of addressing field conditions not accounted for in the original plans. All final pay quantities were reviewed and approved by the City of Austin.

Fiscal Impact

From/To	Acct No.	Description	Amount
---------	----------	-------------	--------

Attachments

1607-102 Pearson Ranch Road CO No. 5

Form Review

Inbox

County Judge Exec Asst.

Form Started By: Dawn Haggard

Final Approval Date: 02/22/2018

Reviewed By

Wendy Coco

Date

02/22/2018 08:46 AM

Started On: 02/20/2018 03:20 PM

Received

Received

RECEIVED
FEB 19 2018
BY: PST

FEB 16 2018

FEB 20 2018

WILLIAMSON COUNTY, TEXAS

HNTB Corporation
Round Rock

CHANGE ORDER NUMBER: 5

1. CONTRACTOR: Jimmy Evans Construction

Project: 1607-102

2. Change Order Work Limits: Sta. 30+00 to Sta. 98+00

Roadway: Pearson Ranch Road Extension

3. Type of Change(on federal-aid non-exempt projects): Minor (Major/Minor)

CSJ Number: _____

4. Reasons: 2E (3 Max. - In order of importance - Primary first)

5. Describe the work being revised:

2E: Differing Site Conditions (unforeseeable). Miscellaneous difference in site conditions (unforeseeable). This Change Order provides the final balancing for the overrun/underrun of Contract quantities paid for by the COA. Changes to final quantities on the project were the result of addressing field conditions not accounted for in the original plans. All final pay quantities were reviewed and approved by the City of Austin.

6. Work to be performed in accordance with Items: See attached.

7. New or revised plan sheet(s) are attached and numbered: _____

8. New Special Provisions/Specifications to the contract are attached: Yes No

9. New Special Provisions to Item N/A No. N/A, Special Specification Item N/A are attached.

Each signatory hereby warrants that each has the authority to execute this Change Order (CO).

The contractor must sign the Change Order and, by doing so, agrees to waive any and all claims for additional compensation due to any and all other expenses, additional changes for time, overhead and profit, or loss of compensation as a result of this change

The following information must be provided

Time Ext. #: N/A Days added on this CO: 0

Amount added by this change order: (\$2,831.05)

THE CONTRACTOR Date 2/16/18

By [Signature]

Typed/Printed Name Ronnie Dwyer

Typed/Printed Title Const. Man

RECOMMENDED FOR EXECUTION:

[Signature] P.E. 2/16/18
Project Manager Date

N/A
Design Engineer Date

[Signature] 2/2/17
Program Manager Date

[Signature] 2/15/18
City Engineer Date

County Commissioner Precinct 1 Date
 APPROVED REQUEST APPROVAL

County Commissioner Precinct 2 Date
 APPROVED REQUEST APPROVAL

County Commissioner Precinct 3 Date
 APPROVED REQUEST APPROVAL

County Commissioner Precinct 4 Date
 APPROVED REQUEST APPROVAL

Design Engineer's Seal:
see attached plan sheets

County Judge Date
 APPROVED

WILLIAMSON COUNTY, TEXAS

CHANGE ORDER NUMBER: 5

Project # 1607-102

TABLE A: Force Account Work and Materials Placed into Stock

	LABOR	HOURLY RATE			HOURLY RATE

TABLE B: Contract Items:

ITEM	DESCRIPTION	UNIT	UNIT PRICE	ORIGINAL + PREVIOUSLY REVISED		ADD or (DEDUCT)	NEW		OVERRUN/UNDERRUN
				QUANTITY	ITEM COST	QUANTITY	QUANTITY	ITEM COST	
430S-A	P.C. CONCRETE CURB AND GUTTER	LF	\$38.00	20.00	\$760.00	(20.00)	0.00	\$0.00	(\$760.00)
504S-3W	ADJUST WATER VALVE BOX TO GRADE	EA	\$655.00	2.00	\$1,310.00	2.00	4.00	\$2,620.00	\$1,310.00
506S-4WM	MINOR MANHOLE ADJUSTMENT	EA	\$1,100.00	7.00	\$7,700.00	1.00	8.00	\$8,800.00	\$1,100.00
509S-1	TRENCH EXCAVATION SAFETY PROTECTION SYSTEMS (ALL DEPTHS)	LF	\$1.65	117.00	\$193.05	(117.00)	0.00	\$0.00	(\$193.05)
510-AWRJ-6	FACTORY RESTRAINED JOINT PIPE, 6IN. DIA. CLASS 350 DUCTILE IRON (ALL DEPTHS) INCLUDING EXCAVATION AND BACKFILL	LF	\$76.00	13.00	\$988.00	(13.00)	0.00	\$0.00	(\$988.00)
511-S-B	ADJUST EXISTING FIRE HYDRANT (511-S-17)	EA	\$3,300.00	2.00	\$6,600.00	(1.00)	1.00	\$3,300.00	(\$3,300.00)
TOTALS					\$17,551.05			\$14,720.00	(\$2,831.05)

CHANGE ORDER REASON(S) CODE CHART

<p>1. Design Error or Omission</p>	<p>1A. Incorrect PS&E 1B. Other</p>
<p>2. Differing Site Conditions (unforeseeable)</p>	<p>2A. Dispute resolution (expense caused by conditions and/or resulting delay) 2B. Unavailable material 2C. New development (conditions changing after PS&E completed) 2D. Environmental remediation 2E. Miscellaneous difference in site conditions (unforeseeable)(Item 9) 2F. Site conditions altered by an act of nature 2G. Unadjusted utility (unforeseeable) 2H. Unacquired Right-of-Way (unforeseeable) 2I. Additional safety needs (unforeseeable) 2J. Other</p>
<p>3. County Convenience</p>	<p>3A. Dispute resolution (not resulting from error in plans or differing site conditions) 3B. Public relations improvement 3C. Implementation of a Value Engineering finding 3D. Achievement of an early project completion 3E. Reduction of future maintenance 3F. Additional work desired by the County 3G. Compliance requirements of new laws and/or policies 3H. Cost savings opportunity discovered during construction 3I. Implementation of improved technology or better process 3J. Price adjustment on finished work (price reduced in exchange for acceptance) 3K. Addition of stock account or material supplied by state provision 3L. Revising safety work/measures desired by the County 3M. Other</p>
<p>4. Third Party Accommodation</p>	<p>4A. Failure of a third party to meet commitment 4B. Third party requested work 4C. Compliance requirements of new laws and/or policies (impacting third party) 4D. Other</p>
<p>5. Contractor Convenience</p>	<p>5A. Contractor exercises option to change the traffic control plan 5B. Contractor requested change in the sequence and/or method of work 5C. Payment for Partnering workshop 5D. Additional safety work/measures desired by the contractor 5E. Other</p>
<p>6. Untimely ROW/Utilities</p>	<p>6A. Right-of-Way not clear (third party responsibility for ROW) 6B. Right-of-Way not clear (County responsibility for ROW) 6C. Utilities not clear 6D. Other</p>

Williamson County Road Bond Program

**Pearson Ranch Road Extension
Williamson County Project No. 1607-102**

Change Order No. 5

Reason for Change

This Change Order provides the final balancing for the overrun/underrun of Contract quantities for the items paid for by the City of Austin. Changes to the final quantities on the project were the result of addressing field conditions not accounted for in the original plans. All final pay quantities were reviewed and approved by the City of Austin.

This Change Order results in a net decrease of \$2,831.05 to the Contract amount, for an adjusted Contract total of \$4,587,900.84. The original Contract amount was \$4,516,178.77. As a result of this and all Change Orders to-date, \$71,722.07 has been added to the Contract. Of the \$71,722.07 added to the Contract, the City of Austin is responsible for \$2,410.00 (.03%) for waterline changes and the County is responsible for the remaining \$71,427.97 (1.56%) for changes to the roadway extension. Zero (0) additional days will be added to the Contract as a result of this Change Order.

HNTB Corporation

James Klotz, P.E.

Commissioners Court - Regular Session

28.

Meeting Date: 02/27/2018

Pearson Ranch Road - Change Order No. 4

Submitted By: Dawn Haggard, Road Bond

Department: Road Bond

Agenda Category: Regular Agenda Items

Information

Agenda Item

Discuss, consider, and take appropriate action regarding Change Order No. 4 in the amount of \$154,700.48 for Pearson Ranch Road, a Road Bond Project in Commissioner Pct. 1. Project: P221 Pearson Ranch Road. Funding Source: Road Bond

Background

This Change Order provides the final balancing for the overrun / underrun of Contract quantities. Changes to final quantities on the project were the result of addressing field conditions not accounted for in the original plans. This Change Order also adds items to pay for additional work that includes an access road to the water quality pond and removal of existing bollards within the ROW.

Fiscal Impact

From/To	Acct No.	Description	Amount
---------	----------	-------------	--------

Attachments

1607-102 Pearson Ranch Road CO#4

Form Review

Inbox

County Judge Exec Asst.

Form Started By: Dawn Haggard

Final Approval Date: 02/22/2018

Reviewed By

Wendy Coco

Date

02/22/2018 08:46 AM

Started On: 02/20/2018 03:27 PM

Received
FEB 16 2018

Received

RECEIVED
FEB 19 2018
BY: PST

WILLIAMSON COUNTY, TEXAS

FEB 20 2018

CHANGE ORDER NUMBER: 4

HNTB Corporation
Round Rock

1. CONTRACTOR: Jimmy Evans Construction

2. Change Order Work Limits: Sta. 30+00 to Sta. 98+00

3. Type of Change(on federal-aid non-exempt projects): Minor (Major/Minor)

4. Reasons: 2E, 1A, 3F (3 Max. - In order of importance - Primary first)

Project: 1607-102

Roadway: Pearson Ranch Road Extension

CSJ Number:

5. Describe the work being revised:

2E: Differing Site Conditions (unforeseeable). Miscellaneous difference in site conditions (unforeseeable). This Change Order provides the final balancing for the overrun/underrun of Contract quantities. Changes to final quantities on the project were the result of addressing field conditions not accounted for in the original plans, including additional boring due to unknown utility conflict. 1A. Design Error or Omission. Incorrect PS&E. This Change Order corrects multiple discrepancies in quantities between the plans and Quantity Summaries. 3F County Convenience. Additional work desired by the County. This Change Order pays for a road to the water quality pond for maintenance access, removal of existing bollards within the ROW, additional signs and object markers.

6. Work to be performed in accordance with Items: See attached.

7. New or revised plan sheet(s) are attached and numbered:

8. New Special Provisions/Specifications to the contract are attached: Yes No

9. New Special Provisions to Item N/A No. N/A, Special Specification Item N/A are attached.

Each signatory hereby warrants that each has the authority to execute this Change Order (CO).

The contractor must sign the Change Order and, by doing so, agrees to waive any and all claims for additional compensation due to any and all other expenses, additional changes for time, overhead and profit, or loss of compensation as a result of this change.

The following information must be provided

Time Ext. #: N/A Days added on this CO: 0

Amount added by this change order: \$154,700.48

THE CONTRACTOR Date 2/15/18
By: [Signature]
Typed/Printed Name Ronnie Puencz
Typed/Printed Title Const. Manag

RECOMMENDED FOR EXECUTION:

[Signature] P.E. 2/16/18
Project Manager Date

N/A
Design Engineer Date

[Signature] 2/20/18
Program Manager Date

City Engineer Date

Design Engineer's Seal:

see attached plan sheets

County Commissioner Precinct 1 Date
 APPROVED REQUEST APPROVAL

County Commissioner Precinct 2 Date
 APPROVED REQUEST APPROVAL

County Commissioner Precinct 3 Date
 APPROVED REQUEST APPROVAL

County Commissioner Precinct 4 Date
 APPROVED REQUEST APPROVAL

County Judge Date
 APPROVED

WILLIAMSON COUNTY, TEXAS

CHANGE ORDER NUMBER: 4

Project # 1607-102

TABLE A: Force Account Work and Materials Placed into Stock

	LABOR	HOURLY RATE			HOURLY RATE

TABLE B: Contract Items:

ITEM	DESCRIPTION	UNIT	UNIT PRICE	ORIGINAL + PREVIOUSLY REVISED		ADD or (DEDUCT)	NEW		OVERRUN/ UNDERRUN
				QUANTITY	ITEM COST	QUANTITY	QUANTITY	ITEM COST	
104-6015	REMOVING CONC (SIDEWALKS)	SY	\$15.00	268.00	\$4,020.00	16.60	284.60	\$4,269.00	\$249.00
160-WC02	FURNISH AND PLACE TOPSOIL (4")	SY	\$2.00	11,917.00	\$23,834.00	22,979.14	34,896.14	\$69,792.28	\$45,958.28
162-6002	BLOCK SODDING	SY	\$4.00	2,892.00	\$11,568.00	(2,892.00)	0.00	\$0.00	(\$11,568.00)
164-WC01	SEEDING FOR EROSION CONTROL (TY 4)	SY	\$0.21	4,471.00	\$938.91	(4,471.00)	0.00	\$0.00	(\$938.91)
164-WC07	SEEDING FOR EROSION CONTROL (TY 7)	SY	\$0.56	8,942.00	\$5,007.52	25,954.14	34,896.14	\$19,541.84	\$14,534.32
164-WC10	SEEDING FOR EROSION CONTROL (TY 10)	SY	\$0.19	4,471.00	\$849.49	(4,471.00)	0.00	\$0.00	(\$849.49)
169-6001	SOIL RETENTION BLANKETS (CL 1) (TY A)	SY	\$1.50	11,834.00	\$17,751.00	23,062.14	34,896.14	\$52,344.21	\$34,593.21
247-6044	FL BS (CMP IN PLACE)(TY A GR 4)(FNL POS)	CY	\$42.00	13,686.00	\$574,812.00	(103.11)	13,582.89	\$570,481.38	(\$4,330.62)
260-6001	LIME (HYDRATED LIME) (DRY)	TON	\$170.00	294.00	\$49,980.00	(55.72)	238.28	\$40,507.60	(\$9,472.40)
260-6027	LIME TRT (EXIST MATERIAL) (8")	SY	\$2.50	40,812.00	\$102,030.00	(27,114.00)	13,698.00	\$34,245.00	(\$67,785.00)
310-6027	PRIME COAT (MC-30 OR AE-P)	GAL	\$3.20	6,418.00	\$20,537.60	57.00	6,475.00	\$20,720.00	\$182.40
316-6193	AGGR (TY-D GR-5 SAC-B)	CY	\$81.00	193.00	\$15,633.00	32.00	225.00	\$18,225.00	\$2,592.00
316-6413	ASPH (AC-15P, HFRS-2P OR CRS-2P)	GAL	\$3.20	8,022.00	\$25,670.40	(572.00)	7,450.00	\$23,840.00	(\$1,830.40)
340-6011	D-GR HMA (SQ) TY-B PG64-22	TON	\$80.00	530.00	\$42,400.00	121.36	651.36	\$52,108.80	\$9,708.80
341-6027	D-GR HMA (SQ) TY-C PG70-22	TON	\$80.00	7,380.00	\$590,400.00	500.05	7,880.05	\$630,404.00	\$40,004.00
402-6001	TRENCH EXCAVATION	LF	\$1.60	2,489.00	\$3,982.40	64.00	2,553.00	\$4,084.80	\$102.40
464-6003	RC PIPE (CL III)(18IN)	LF	\$55.00	791.00	\$43,505.00	(242.00)	549.00	\$30,195.00	(\$13,310.00)
TOTALS					\$1,532,919.32			\$1,570,758.91	\$37,839.59

WILLIAMSON COUNTY, TEXAS

CHANGE ORDER NUMBER: 4

Project # 1607-102

TABLE B: Contract Items (Continued)

ITEM	DESCRIPTION	UNIT	UNIT PRICE	ORIGINAL + PREVIOUSLY REVISED		ADD or (DEDUCT)	NEW		OVERRUN/ UNDERRUN
				QUANTITY	ITEM COST	QUANTITY	QUANTITY	ITEM COST	
464-6005	RC PIPE (CL III)(24IN)	LF	\$66.00	843.00	\$55,638.00	339.00	1,182.00	\$78,012.00	\$22,374.00
479-6001	ADJUSTING MANHOLES	EA	\$688.00	8.00	\$5,504.00	11.00	19.00	\$13,072.00	\$7,568.00
506-6003	ROCK FILTER DAMS (INSTALL)(TY 3)	LF	\$42.00	105.00	\$4,410.00	25.00	130.00	\$5,460.00	\$1,050.00
506-6011	ROCK FILTER DAMS (REMOVE)	LF	\$6.60	105.00	\$693.00	25.00	130.00	\$858.00	\$165.00
506-6038	TEMP SDMT CONTROL FENCE (INSTALL)	LF	\$2.30	8,712.00	\$20,037.60	467.00	9,179.00	\$21,111.70	\$1,074.10
506-6039	TEMP SDMT CONTROL FENCE (REMOVE)	LF	\$0.15	8,712.00	\$1,306.80	467.00	9,179.00	\$1,376.85	\$70.05
529-6008	CONC CURB & GUTTER (TY II)	LF	\$12.00	16,236.00	\$194,832.00	(39.00)	16,197.00	\$194,364.00	(\$468.00)
WC-106	WIRE FENCING (TY C)	LF	\$6.80	2,563.00	\$17,428.40	487.00	3,050.00	\$20,740.00	\$3,311.60
644-6060	IN SM RD SN SUP&AM TYTWT(1)WS(P)	EA	\$400.00	6.00	\$2,400.00	8.00	14.00	\$5,600.00	\$3,200.00
644-6071	RELOCATE SM RD SN SUP & AM TY TWT	EA	\$400.00	3.00	\$1,200.00	4.00	7.00	\$2,800.00	\$1,600.00
666-6035	REFL PAV MRK TY I (W) 8" (SLD)(090 MIL)	LF	\$0.80	2,372.00	\$1,897.60	(718.00)	1,654.00	\$1,323.20	(\$574.40)
666-6041	REFL PAV MRK TY I (W) 12" (SLD)(090 MIL)	LF	\$3.40	757.00	\$2,573.80	(757.00)	0.00	\$0.00	(\$2,573.80)
666-6047	REFL PAV MRK TY I (W) 24" (SLD)(090 MIL)	LF	\$6.50	146.00	\$949.00	452.00	598.00	\$3,887.00	\$2,938.00
666-6053	REFL PAV MRK TY I (W) (ARROW) (090 MIL)	EA	\$136.00	24.00	\$3,264.00	(7.00)	17.00	\$2,312.00	(\$952.00)
666-6077	REFL PAV MRK TY I (W) (WORD) (090 MIL)	EA	\$136.00	27.00	\$3,672.00	(12.00)	15.00	\$2,040.00	(\$1,632.00)
666-6299	RE PM W/ RET REQ TY I (W) 4" (BRK) (090 MIL)	LF	\$0.40	5,535.00	\$2,214.00	(2,305.00)	3,230.00	\$1,292.00	(\$922.00)
666-6302	RE PM W/ RET REQ TY I (W) 4" (SLD) (090 MIL)	LF	\$0.40	14,544.00	\$5,817.60	1,502.00	16,046.00	\$6,418.40	\$600.80
672-6010	REFL PAV MRKR TY II-C-R	EA	\$3.30	499.00	\$1,646.70	(192.00)	307.00	\$1,013.10	(\$633.60)
7012-6001	CURB INLET SEDIMENT PROTECTION	LF	\$7.00	350.00	\$2,450.00	(105.00)	245.00	\$1,715.00	(\$735.00)
COA-4325	CONC SIDEWALKS (6")	SY	\$52.00	5,524.00	\$287,248.00	79.58	5,603.58	\$291,386.16	\$4,138.16
COA-4335	DRIVEWAYS (CONC)	SY	\$62.00	208.00	\$12,896.00	494.60	702.60	\$43,561.20	\$30,665.20
WC9020-0001	CONTROLLED LOW STRENGTH MATERIAL (CLSM)	CY	\$100.00	500.00	\$50,000.00	(281.00)	219.00	\$21,900.00	(\$28,100.00)
WC9020-0002	BACKFILL (0.5"-1")	CY	\$70.00	300.00	\$21,000.00	80.00	380.00	\$26,600.00	\$5,600.00
WC9020-0003	BACKFILL (3"-5")	CY	\$56.00	3,100.00	\$173,600.00	(423.75)	2,676.25	\$149,870.00	(\$23,730.00)
WC9020-0005	CLAY CAP	CY	\$34.00	100.00	\$3,400.00	(7.00)	93.00	\$3,162.00	(\$238.00)
999-WC01	FORCE ACCOUNT (CAVE/VOID MITIGATION)	DOL	\$1.00	150,000.00	\$150,000.00	(150,000.00)	0.00	\$0.00	(\$150,000.00)
999-WC02	FORCE ACCOUNT	DOL	\$1.00	25,000.00	\$25,000.00	(21,958.39)	3,041.61	\$3,041.61	(\$21,958.39)
341-WC01	FORCE ACCOUNT - ESTIMATED PLACEMENT AND PRODUCTION BOUNDS/PENALTY (TY B)	DOL	\$1.00	3,200.00	\$3,200.00	(3,200.00)	0.00	\$0.00	(\$3,200.00)
341-WC02	FORCE ACCOUNT - ESTIMATED PLACEMENT AND PRODUCTION BOUNDS/PENALTY (TY C SURFACE)	DOL	\$1.00	60,500.00	\$60,500.00	(58,493.49)	2,006.51	\$2,006.51	(\$58,493.49)
585-WC01	FORCE ACCOUNT - ESTIMATED RIDE QUALITY BONUS/PENALTY	DOL	\$1.00	11,400.00	\$11,400.00	(11,146.00)	254.00	\$254.00	(\$11,146.00)
The "Totals" from Table B of the previous work sheet:						\$1,532,919.32		\$1,570,758.91	\$37,839.59
TOTALS						\$2,659,097.82		\$2,475,935.64	(\$183,162.18)

CHANGE ORDER REASON(S) CODE CHART

<p>1. Design Error or Omission</p>	<p>1A. Incorrect PS&E 1B. Other</p>
<p>2. Differing Site Conditions (unforeseeable)</p>	<p>2A. Dispute resolution (expense caused by conditions and/or resulting delay) 2B. Unavailable material 2C. New development (conditions changing after PS&E completed) 2D. Environmental remediation 2E. Miscellaneous difference in site conditions (unforeseeable)(Item 9) 2F. Site conditions altered by an act of nature 2G. Unadjusted utility (unforeseeable) 2H. Unacquired Right-of-Way (unforeseeable) 2I. Additional safety needs (unforeseeable) 2J. Other</p>
<p>3. County Convenience</p>	<p>3A. Dispute resolution (not resulting from error in plans or differing site conditions) 3B. Public relations improvement 3C. Implementation of a Value Engineering finding 3D. Achievement of an early project completion 3E. Reduction of future maintenance 3F. Additional work desired by the County 3G. Compliance requirements of new laws and/or policies 3H. Cost savings opportunity discovered during construction 3I. Implementation of improved technology or better process 3J. Price adjustment on finished work (price reduced in exchange for acceptance) 3K. Addition of stock account or material supplied by state provision 3L. Revising safety work/measures desired by the County 3M. Other</p>
<p>4. Third Party Accommodation</p>	<p>4A. Failure of a third party to meet commitment 4B. Third party requested work 4C. Compliance requirements of new laws and/or policies (impacting third party) 4D. Other</p>
<p>5. Contractor Convenience</p>	<p>5A. Contractor exercises option to change the traffic control plan 5B. Contractor requested change in the sequence and/or method of work 5C. Payment for Partnering workshop 5D. Additional safety work/measures desired by the contractor 5E. Other</p>
<p>6. Untimely ROW/Utilities</p>	<p>6A. Right-of-Way not clear (third party responsibility for ROW) 6B. Right-of-Way not clear (County responsibility for ROW) 6C. Utilities not clear 6D. Other</p>

Williamson County Road Bond Program

Pearson Ranch Road Extension Williamson County Project No. 1607-102

Change Order No. 4

Reason for Change

This Change Order provides the final balancing for the overrun / underrun of Contract quantities. Changes to final quantities on the project were the result of addressing field conditions not accounted for in the original plans. This Change Order also adds items to pay for additional work that includes an access road to the water quality pond and removal of existing bollards within the ROW.

Following are descriptions of the new items added to the Contract on this Change Order.

1. Item 100-WC01 Dead Tree Removal. Additional trees were removed because they died, after the initial clearing of the right of way. These trees were initially designated to be saved.
2. Item 100-WC02 Remove Existing Bollards. The County requested that existing bollards within the right-of-way be removed.
3. Item WC106-001 Additional Fence Braces. Additional bracing was added to steel posts in curve sections.
4. Item 476-WC01 Revised Bore Cost. The Contractor bored 270 linear feet, before encountering a conflict with an existing AT&T underground utility line. The County agreed to pay for the initial bore at the bid price minus the cost of the encasement pipe and the storm sewer pipe.
5. Item 476-WC02 Impact due to encountering the existing AT&T line, as discussed in above Item #4. The Bore subcontractor encountered an existing AT&T line during boring operations. The line was not marked by One-call and was not known to be in conflict by AT&T, until contractor hit the line. The County agreed to pay costs for 4 days of labor and equipment to pothole and find the existing utility and make repairs to equipment; 7 days of equipment standby time while resolution was determined; and 11 days of labor and equipment to remove the casing pipe from the original bore.
6. Item 502-WC01 Extra Signs and Barricades. Additional electronic message boards used during reconstruction of Iveans Way and Neenah that notified traffic of road closures and detours. Additional signs necessary to open a portion of the roadway from beginning of project to the Bus Transportation Facility. An

arrowboard was also added, because it was necessary for lane closures from additional work to additional work at Neenah Avenue.

7. Item 512 Concrete Traffic Barrier. Placed between RM 620 and the water quality Pond (WQP) to prevent vehicles that drive over the curb from driving into Water Quality Pond (WQP).
8. Item 531-WC01 Retrofit ADA Ramp. Plans called for cross walk near the new middle school but did not include pay item to retrofit pedestrian ramp at the location.
9. Item 644-WC01 Additional street name signs.
10. Item 644-WC02 Additional "All Way" signs to Stop signs.
11. Item 644-6076 Sign Removals.
12. Item 658-WC01 Installation of Object Markers.
13. Item WC9019-001 Pond Access Road. This item provided access to the WQP from Pearson Ranch Road to the pond gates for maintenance.
14. Item WC9019-002 Concrete Trickle Channel at WQP. Concrete trickle channel from WQP to drainage structure added in the field to prevent erosion.
15. Item WC9019-003 Special Shoring at WQP. Plans did not clearly show limits of available right-of-way (ROW) for laying slope back along north side of WQP, so Contractor applied Shotcrete to slope for stabilization.
16. WC9020-006 Void Investigation. Contractor drilled core holes during investigation to find karst features called out to be backfilled in the plans. No voids were found. This item pays for additional cores required during investigation.

Following is a summary of the new items required for this Change Order.

	ITEM	DESCRIPTION	QTY	UNIT
1.	100-WC01	DEAD TREE REMOVAL	1.00	LS
2.	100-WC02	REMOVE EXISTING BOLLARDS	1.00	LS
3.	WC106-00	ADDITIONAL FENCING	1.00	LS
4.	476-WC01	JACK AND BORE (36IN)(NO STL CASING AND RC PIPE	270	LF
5.	476-WC02	IMPACT DUE TO CONFLICT WITH UNKNOWN UTILITY	1.00	LS

6.	502-WC01	ADDITIONAL SIGNS AND BARRICADES	1.00	LS
7.	512-WC01	TEMPORARY CTB BARRIER WALL (JERSEY)	1.00	LS
8.	531-WC01	MODIFY EXISTING PED RAMP	1.00	LS
9.	644-WC01	ADD STREET NAME SIGNS	6.00	EA
10.	644-WC02	ADD "ALL WAY" SIGNS TO STOP SIGNS	4.00	EA
11.	644-6076	REMOVE SM RD SN SUP & AM	4.00	EA
12.	658-WC01	INSTL OM ASSM (OM-4)(WC)	21.00	EA
13.	WC9019-001	POND ACCESS ROAD	1.00	LS
14.	WC9019-002	TRICKLE CHANNEL AT WQP	1.00	LS
15.	WC9019-003	SPECIAL SHORING AT WQP	1.00	LS
16.	WC9020-006	VOID INVESTIGATION	1.00	LS

This Change Order results in a net increase of \$154,700.48 to the Contract amount, for an adjusted Contract total of \$4,590,731.89. The original Contract amount was \$4,516,178.77. As a result of this and all Change Orders to-date, \$74,553.12 has been added to the Contract, which results in a 1.65% increase in the Contract cost. Zero days will be added to the Contract as a result of this Change Order.

HNTB Corporation
James Klotz, P.E.

Project 1607-102: Pearson Ranch Road
 Summary of Force Account Work & New Items

1. Item 100-WC01 Dead Tree Removal

Additional trees were removed because they were dead after the initial clearing of the right of way. Trees were originally designated to be saved.

Work performed by JEvans.

Labor rates shown in JE Cost Report include hourly wage plus 55% Burden.

Labor: $\$152.97 \times 1.15 = \175.92 \$175.92

Equipment: $\$108.03 \times 1.15 = \124.23 \$124.23

Trucking $\$75.00 \times 6 \text{ hrs} = \$450.00 \times 1.05 \text{ markup} =$ \$472.50

Total: \$772.65

$\$772.65 \times 1.01 \text{ Bond} = \780.38 **\$780.38**

2. Item 100-WC02 Remove Existing Bollards

County requested that bollards preventing access to the right of way prior to construction of the roadway be removed.

Agreed to price of \$7500.00 **\$7,500.00**

3. Item WC106-001 Additional Fence Braces

Property owner requested additional bracing on steel posts in curve sections.

Work performed by Subcontractor

$\$2200.00 \times 1.05 \text{ mark up} = \$2,310.00$

$\$2310.00 \times 1.01 \text{ Bond} = \$2,333.10$ **\$2,333.10**

4. Item 476-WC01 JACK AND BORE (36IN)(NO STL CASING AND RC PIPE

A. Contractor bored 270' before encountering conflict with existing ATT underground utility line. The County agrees to pay for this portion of the work at the bid price minus the cost of the casing pipe and the storm sewer pipe.

Bid Price $\$560.00$ per LF minus $\$79.60$ per LF for cost of casing pipe minus $\$19.37$ per LF for cost of RCPipe = $\$461.03$ per LF $\times 270' = \$124,478.10$ **\$124,478.10**

B. Final bore was paid at Plan Quantity and bid price of $310' \times \$560.00 = \$173,600.00$

5. Item 476-WC02 ATT Conflict with Bore

Boring subcontractor encountered an existing ATT line during boring operations, as discussed in Item #4 above. The line was not marked by one call and not known to be in conflict by ATT until contractor hit the line. County agrees to pay costs for 4 days of labor and equipment to pothole to find existing utility and repair equipment, 7 days of equipment standby time while resolution is determined, and 11 days of labor and equipment to remove the casing pipe from the original bore.

Labor during pothole \$ 4,111.86

Labor during standby and rework \$10,385.70

Equipment during standby \$17,706.08

Equipment during pothole and rework \$86,515.33

Total \$118,718.75

$\$118,718.75 \times 1.05 \text{ markup} = \$124,654.69$

$\$124,654.69 \times 1.01 \text{ Bond} = \$125,901.23$ **\$125,901.23**

Project 1607-102: Pearson Ranch Road
 Summary of Force Account Work & New Items

6. Item 502-WC01 Extra Signs and Barricades
- Electronic message boards used during reconstruction of Iveans Way and Neenah to notify traffic of road closures and detours.
 - Additional signs necessary to open portion of roadway from beginning of project to Bus Transportation Facility.
 - Arrowboard was necessary for lane closures due to additional work to reconstruct a portion of Neenah Ave.

Work performed and materials supplied by Subcontractor AWP

Inv 184197A/ticket 28410	Electronic Message Boards	\$2922.75
Inv 174894A/ticket 26842	Additional Temporary signs	994.32
Inv 183736A/ticket 27346	Additional barricades	673.88
Inv 182916A/ticket 26953	Additional Temporary signs	1055.43
Inv 183164A/ticket 26953	Additional Temporary signs	746.95
Inv 183164A/ticket 25694	Additional Temporary signs	681.98
Inv 183164A/ticket 27433	Additional Temporary signs	995.92
Inv 183164A/ticket 28393	Arrowboard	1729.83
Inv 183164A/ticket 26917	Additional Temporary signs	<u>541.29</u>
	Total	\$10,342.35
	\$10342.35 X 1.05 markup	= \$10,859.47
	\$10859.47 X 1.01 Bond	= \$10,968.06
	Grand Total	\$10,968.06

7. Item 512-WC01 Concrete Traffic Barrier
- Concrete traffic barrier was placed between WQP and RM 620/SH 45. Marks on pavement and curb indicated that vehicles were driving over curb and there was risk of driving into pond. CTB rented from and supplied by Aaron Concrete Constructors.

Labor rates shown in JE Cost Reports include hourly wage plus 55% burden.

Materials: \$3750.00 X 1.15 markup = \$4312.50	\$4,312.50
Subcontractor Aaron CC \$4325.00 X 1.05 = \$4541.25	\$4,541.25
Subcontractor Tiki Trucking \$1960.00 X 1.05 = \$2058.00	\$2,058.00
JEVans Labor: \$922.21 X 1.15 markup = \$1060.54	\$1,060.54
Equipment: \$1818.24 X 1.15 markup = \$2090.98	<u>\$2,090.98</u>
Total:	\$14,063.27

\$14,063.27 X 1.01 Bond = \$14,203.90 **\$14,203.90**

8. Item 531-WC01 Retrofit ADA Ramp.
- Plans called for cross walk near the new middle school but did not include pay item to retrofit pedestrian ramp at the location.

Agreed to price as submitted. \$1967.39 **\$1,967.39**

9. Item 644-WC01 Additional street name signs.

Agreed to price as submitted. \$62.10 X 6 = \$372.60 **\$372.60**

10. Item 644-WC02 Additional "All Way" signs to Stop signs.

Agreed to price as submitted. \$12.65 X 4 = \$50.60 **\$50.60**

11. Item 644-6076 Sign Removals.

Agreed to price as submitted. \$172.50 X 4 = \$690.00 **\$690.00**

Project 1607-102: Pearson Ranch Road
 Summary of Force Account Work & New Items

12. Item 658-WC01 Installation of Object Markers.
 Agreed to price as submitted. $\$149.50 \times 21 = \$3,139.50$ **\$3,139.50**
13. Item WC9019-001 Pond Access Road
 At the request of the County an access road was constructed from Pearson Ranch Road to the gates of the water quality pond. Access road was added to provide safe route for maintenance. Work performed by JEvans.
 Labor rates shown in JE Cost Report include hourly wage plus 55% burden.
 Labor: $\$3849.80 \times 1.15$ mark up = $\$4,427.27$
 Equipment: $\$7531.22 \times 1.15$ mark up = $\$8,660.90$
 Materials: $\$1775.04 \times 1.15$ mark up = $\$2,041.30$
 Total: $\$15,129.47$
 $\$15,129.47 \times 1.01$ Bond = $\$15,280.76$ **\$15,280.76**
14. Item WC9019-002 Concrete Trickle Channel at WQP
 Concrete trickle channel from WQP to drainage structure added in the field to prevent erosion. Work performed by Subcontractor Greater Austin
 $\$1670.00 \times 1.05$ markup = $\$1753.50$
 $\$1753.50 \times 1.01$ Bond = $\$1771.04$ **\$1,771.04**
15. Item 9019-003 Special Shoring required at WQP
 County agrees to pay invoice price for tree removal and construction of temporary Special shoring(shotcrete) along north side of water quality pond. Plans did not show enough detail for contractor to have included shoring in original bid. County agrees to pay invoice cost of $\$22,805.50$. **\$22,805.50**
16. Item 9020-006 Void Investigation
 At County request, subcontractor drilled additional bore holes in attempt to find voids called out in the plans. Plans designated voids for backfilling with flowable fill. Voids were not found despite additional work.
 Labor rates shown in JE Cost Report include hourly wage, plus 55% burden.
 Work performed by Subcontractor ESSI drill rig & crew.
 $\$1,789.35 \times 1.05$ markup = $\$1,878.82$
 JEvans Labor: $\$888.00 \times 1.55$ mark up = $\$1,376.40$
 $\$1,376.40 \times 1.15$ mark up = $\$1,582.86$
 Equipment: $\$76.22$ cost/hr $\times 24.00$ hr = $\$1829.28$
 $\$1829.28 \times 1.15$ mark up = $\$2,103.67$
 Total: $\$5,565.35$
 $\$5565.35 \times 1.01$ Bond = $\$5621.00$ **\$5,621.00**

Commissioners Court - Regular Session

29.

Meeting Date: 02/27/2018

Doucet Associates PSA Smith Branch Flood Control and Drainage Engineering Services

Submitted For: Robert Daigh

Submitted By: Sarah Ramos, Infrastructure

Department: Infrastructure

Division: Road & Bridge

Agenda Category: Regular Agenda Items

Information

Agenda Item

Discuss, consider and take appropriate action on new Professional Service Agreement with Doucet & Associates, Inc. to provide Smith Branch Flood Control and Drainage Engineering Services for Williamson County Road and Bridge.

Background

Fiscal Impact

From/To	Acct No.	Description	Amount
---------	----------	-------------	--------

Attachments

PSA - Doucet - Smith Branch - Fld Control & Drainage Eng. Srv.

Form Review

Inbox

County Judge Exec Asst.
Form Started By: Sarah Ramos
Final Approval Date: 02/22/2018

Reviewed By

Wendy Coco

Date

02/22/2018 09:27 AM
Started On: 02/21/2018 03:43 PM

WILLIAMSON COUNTY
CONTRACT FOR ENGINEERING SERVICES

FIRM: Doucet & Associates, Inc. (“**Engineer**”)
ADDRESS: 7401B Hwy 71 West, Suite 160, Austin, TX 78735
PROJECT: Smith Branch Flood Control and Drainage Engineering Services (“**Project**”)

THE STATE OF TEXAS §
§
COUNTY OF WILLIAMSON §

THIS CONTRACT FOR ENGINEERING SERVICES (“Contract”) is made and entered into, effective as the date of the last party’s execution hereinbelow, by and between Williamson County, Texas, a political subdivision of the State of Texas, whose offices are located at 710 Main Street, Suite 101, Georgetown, Texas, 78626 (hereinafter referred to as “County”), and Engineer, and such Contract is for the purpose of contracting for professional engineering services.

RECITALS:

WHEREAS, V.T.C.A., Government Code §2254.002(2)(A)(vii) under Subchapter A entitled “Professional Services Procurement Act” provides for the procurement by counties of services of professional engineers; and

WHEREAS, County and Engineer desire to contract for such professional engineering services; and

WHEREAS, County and Engineer wish to document their agreement concerning the requirements and respective obligations of the parties;

NOW, THEREFORE, WITNESSETH:

That for and in consideration of the mutual promises contained herein and other good and valuable considerations, and the covenants and agreements hereinafter contained to be kept and performed by the respective parties hereto, it is agreed as follows:

ARTICLE 1
CONTRACT DOCUMENTS AND APPLICABLE PROJECT DOCUMENTS

A. Contract Documents. The Contract Documents consist of this Contract, any exhibits attached hereto (which exhibits are hereby incorporated into and made a part of this Contract), any fully executed Work Authorizations; any fully executed Supplemental Work Authorizations and all fully executed Contract Amendments (as defined herein in Article 14) which are subsequently issued. These form the entire contract, and all are as fully a part of this Contract as if attached to this Contract or repeated herein.

B. Project Documents. In addition to any other pertinent and necessary Project documents, the following documents shall be used in the development of the Project:

- A. TxDOT 2011 Texas Manual of Uniform Traffic Control Devices for Streets and Highways, including latest revisions
- B. Texas Department of Transportation's Standard Specifications for Construction of Highways, Streets, and Bridges, 2014 (English units)
- C. National Environmental Policy Act (NEPA)
- D. Texas Accessibility Standards (TAS) of the Architectural Barriers Act, Article 9102, Texas Civil Statutes, Effective April 4, 1994, including latest revisions
- E. Americans with Disabilities Act (ADA) Regulations
- F. U.S. Army Corps Regulations
- G. International Building Code, current edition as updated
- H. Williamson County Design Criteria & Project Development Manual, latest edition
- I. Williamson County Multi-Corridor Transportation Plan Project Level Environmental Review and Compliance Protocol, latest edition
- J. Williamson County Protocol for Sustainable Roadsides, latest edition
- K. TxDOT Bridge Design Manual - LRFD, latest edition
- L. TxDOT Geotechnical Manual, latest edition

ARTICLE 2
NON-COLLUSION; DEBARMENT; AND FINANCIAL INTEREST
PROHIBITED

A. Non-collusion. Engineer warrants that he/she/it has not employed or retained any company or persons, other than a bona fide employee working solely for Engineer, to solicit or secure this Contract, and that he/she/it has not paid or agreed to pay any company or engineer any fee, commission, percentage, brokerage fee, gifts, or any other consideration, contingent upon or resulting from the award or making of this Contract. For breach or violation of this warranty, County reserves and shall have the right to annul this Contract without liability or, in its discretion and at its sole election, to deduct from the contract price or compensation, or to otherwise recover, the full amount of such fee, commission, percentage, brokerage fee, gift or contingent fee.

B. Debarment Certification. Engineer must sign the Debarment Certification

enclosed herewith as **Exhibit A**.

C. Financial Interest Prohibited. Engineer covenants and represents that Engineer, his/her/its officers, employees, agents, consultants and subcontractors will have no financial interest, direct or indirect, in the purchase or sale of any product, materials or equipment that will be recommended or required for the construction of the Project.

ARTICLE 3
ENGINEERING SERVICES

Engineer shall perform Engineering Services as identified in **Exhibit B** entitled “Engineering Services.”

County will prepare and issue Work Authorizations, in substantially the same form identified and attached hereto as **Exhibit C** and entitled “Work Authorization No. _____”, to authorize the Engineer to perform one or more tasks of the Engineering Services. Each Work Authorization will include a description of the work to be performed, a description of the tasks and milestones, a work schedule for the tasks, definite review times by County and Engineer of all Engineering Services and a fee amount agreed upon by the County and Engineer. The amount payable for a Work Authorization shall be supported by the estimated cost of each work task as described in the Work Authorization. The Work Authorization will not waive the Engineer’s responsibilities and obligations established in this Contract. The executed Work Authorizations shall become part of this Contract.

All work must be completed on or before the date specified in the Work Authorization. The Engineer shall promptly notify the County of any event which will affect completion of the Work Authorization, although such notification shall not relieve the Engineer from costs or liabilities resulting from delays in completion of the Work Authorization. Should the review times or Engineering Services take longer than shown on the Work Authorization, through no fault of Engineer, Engineer may submit a timely written request for additional time, which shall be subject to the approval of the County. Any changes in a Work Authorization shall be enacted by a written Supplemental Work Authorization before additional costs may be incurred. Any Supplemental Work Authorization must be executed by both parties within the period specified in the Work Authorization.

ARTICLE 4
CONTRACT TERM

A. Term. The Engineer is expected to complete the Engineering Services described herein in accordance with the above described Work Authorizations or any Supplemental Work Authorization related thereto. If Engineer does not perform the Engineering Services in accordance with each applicable Work Authorization or any Supplemental Work Authorization related thereto, then County shall have the right to terminate this Contract as set forth below in Article 20. So long as the County elects not to terminate this Contract, it shall continue from day to day until such time as the Engineering Services are completed in accordance with each applicable Work Authorization or any Supplemental Work Authorization related thereto. Any Engineering Services performed or

costs incurred after the date of termination shall not be eligible for reimbursement. Engineer shall notify County in writing as soon as possible if he/she/it determines, or reasonably anticipates, that the Engineering Services will not be completed in accordance with an applicable Work Authorization or any Supplemental Work Authorization related thereto.

B. Work Authorizations. Engineer acknowledges that each Work Authorization is of critical importance, and agrees to undertake all reasonably necessary efforts to expedite the performance of Engineering Services required herein so that construction of the Project will be commenced and completed as scheduled. In this regard, and subject to adjustments in a particular Work Authorization, as provided in Article 3 herein, Engineer shall proceed with sufficient qualified personnel and consultants necessary to fully and timely accomplish all Engineering Services required under this Contract in a professional manner.

C. Commencement of Engineering Services. After execution of this Contract, Engineer shall not proceed with Engineering Services until Engineer has been thoroughly briefed on the scope of the Project and has been notified in writing by the County to proceed, as provided in Article 8.

ARTICLE 5

COMPENSATION AND EXPENSES

County shall pay and Engineer agrees to accept up to the amount shown below as full compensation for the Engineering Services performed and to be performed under this Contract. The basis of compensation for the services of principals and employees engaged in the performance of the Engineering Services shall be based on the Rate Schedule set forth in the attached **Exhibit D**.

The maximum amount payable under this Contract, without modification, is **One Hundred Sixty-One Thousand Two Hundred Fifty Dollars (\$161,250.00)** (the “Compensation Cap”), provided that any amounts paid or payable shall be solely pursuant to a validly issued Work Authorization or any Supplemental Work Authorization related thereto. In no event may the aggregate amount of compensation authorized under Work Authorizations and Supplemental Work Authorizations exceed the Compensation Cap. The Compensation Cap shall be revised equitably only by written Contract Amendments executed by both parties in the event of a change the overall scope of the Engineering Services set forth in **Exhibit B**, as authorized by County.

The Compensation Cap is based upon all labor and non-labor costs estimated to be required in the performance of the Engineering Services provided for under this Contract. Should the actual costs of all labor and non-labor costs rendered under this Contract be less than the above stated Compensation Cap, then Engineer shall receive compensation for only actual fees and costs of the Engineering Services actually rendered and incurred, which may be less than the above stated Compensation Cap.

The Compensation Cap herein referenced may be adjusted for Additional Engineering Services requested and performed only if approved by a written Contract Amendment signed by both parties.

Engineer shall prepare and submit to County monthly progress reports in sufficient detail to support the progress of the Engineering Services and to support invoices requesting monthly payment. The format for such monthly progress reports and invoices must be in a format acceptable to County. Satisfactory progress of Engineering Services shall be an absolute condition of payment.

Engineer shall be reimbursed for actual non-labor and subcontract expenses incurred in the performance of the services under this Contract in accordance with the Williamson County Vendor Reimbursement Policy set forth under **Exhibit E**. Invoices requesting reimbursement for costs and expenditures related to the Project (reimbursables) must be accompanied by copies of the provider's invoice and comply with the Williamson County Vendor Reimbursement Policy. The copies of the provider's invoice must evidence the actual costs billed to Engineer without mark-up.

ARTICLE 6 **METHOD OF PAYMENT**

Payments to Engineer shall be made while Engineering Services are in progress. A monthly progress report, as referenced in Article 5 above (in a form acceptable to the County), shall be submitted to Williamson County Department of Infrastructure, to the attention of the Sr. Director of Infrastructure. Such progress report shall provide a summary of the work accomplished during the billing period for each Work Authorization task with an estimated percentage of completion for the task.

Simultaneous with submission of such progress report, Engineer shall prepare and submit one (1) original of a certified invoice to the Director of Road & Bridge in a form acceptable to the County Auditor. All invoices submitted to County must, at a minimum, be accompanied by an original complete packet of supporting documentation and time sheets detailing hours worked by staff persons with a description of the work performed by such persons. For Additional Engineering Services performed pursuant to this Contract, a separate invoice or itemization of the Additional Engineering Services must be presented with the same aforementioned requirements.

Payments shall be made by County based upon Engineering Services actually provided and performed.^a Upon timely receipt and approval of each statement, County shall make a good faith effort to pay the amount which is due and payable within thirty (30) days of the County Auditor's receipt. County reserves the right to reasonably withhold payment pending verification of satisfactory Engineering Services performed. Engineer has the responsibility to submit proof to County, adequate and sufficient in its determination, that tasks of an applicable Work Authorization or any Supplemental Work Authorization related thereto were completed.

The certified statements shall show the total amount earned to the date of submission and shall show the amount due and payable as of the date of the current statement. Final payment does not relieve Engineer of the responsibility of correcting any errors and/or omissions resulting from his/her/its negligence.

^a See also, Art. 32(P) "Termination of Work Authorization".

Upon submittal of the initial invoice, Engineer shall provide the County Auditor with an Internal Revenue Form W-9, Request for Taxpayer Identification Number and Certification that is complete in compliance with the Internal Revenue Code, its rules and regulations.

ARTICLE 7
PROMPT PAYMENT POLICY

In accordance with Chapter 2251, V.T.C.A., Texas Government Code, payment to Engineer will be made within thirty (30) days of the day on which the performance of services was complete, or within thirty (30) days of the day on which the County Auditor receives a correct invoice for services, whichever is later.

Engineer may charge a late fee (fee shall not be greater than that which is permitted by Texas law) for payments not made in accordance with this prompt payment policy; however, this policy does not apply in the event:

- A. There is a bona fide dispute between County and Engineer concerning the supplies, materials, or equipment delivered or the services performed that causes the payment to be late; or
- B. The terms of a federal contract, grant, regulation, or statute prevent County from making a timely payment with federal funds; or
- C. There is a bona fide dispute between Engineer and a subcontractor/subconsultant or between a subcontractor/subconsultant and its supplier concerning supplies, materials, or equipment delivered or the Engineering Services performed which causes the payment to be late; or
- D. The invoice is not submitted to Williamson County^b in strict accordance with instructions, if any, on the purchase order, or this Contract or other such contractual agreement.

The County Auditor shall document to Engineer the issues related to disputed invoices within ten (10) calendar days of receipt of such invoice. Any non-disputed invoices shall be considered correct and payable per the terms of Chapter 2251, V.T.C.A., Texas Government Code.

ARTICLE 8
COMMENCEMENT OF ENGINEERING SERVICES

The Engineer shall not proceed with any task of the Engineering Services until Engineer has been thoroughly briefed on the scope of the Project and instructed, in writing by the County, to proceed with the applicable Engineering Services. The County shall not be responsible for work performed or costs incurred by Engineer related to any task for which a Work Authorization or a Supplemental Work Authorization related thereto has not been issued and signed by both parties. Engineer shall not be required to perform any work for which a Work Authorization or a Supplemental Work Authorization related thereto has not been issued and signed by both parties.

ARTICLE 9

^b See Art. 6, *supra*.

PROJECT TEAM

County's Designated Representative for purposes of this Contract is as follows:

Williamson County Dept. of Infrastructure
Attn: Director of Road & Bridge
3151 SE Inner Loop, Suite B
Georgetown, Texas 78626

County shall have the right, from time to time, to change the County's Designated Representative by giving Engineer written notice thereof. With respect to any action, decision or determination which is to be taken or made by County under this Contract, the County's Designated Representative may take such action or make such decision or determination or shall notify Engineer in writing of an individual responsible for and capable of taking such action, decision or determination and shall forward any communications and documentation to such individual for response or action. Actions, decisions or determinations by the County's Designated Representative on behalf of County shall be done in his or her reasonable business judgment unless express standards or parameters therefor are included in this Contract, in which case, actions taken by the County's Designated Representative shall be in accordance with such express standards or parameters. Any consent, approval, decision or determination hereunder by the County's Designated Representative shall be binding on County; *provided, however*, the County's Designated Representative shall not have any right to modify, amend or terminate this Contract, an Executed Work Authorization, an executed Supplemental Work Authorization or executed Contract Amendment. County's Designated Representative shall not have any authority to execute a Contract Amendment, Work Authorization or any Supplemental Work Authorization unless otherwise granted such authority by the Williamson County Commissioners Court.

Engineer's Designated Representative for purposes of this Contract is as follows:

Doucet & Associates, Inc.
Duke G. Altman, P.E.
7401B Hwy 71 West, Suite 160
Austin, TX 78735

Engineer shall have the right, from time to time, to change the Engineer's Designated Representative by giving County written notice thereof. With respect to any action, decision or determination which is to be taken or made by Engineer under this Contract, the Engineer's Designated Representative may take such action or make such decision or determination or shall notify County in writing of an individual responsible for and capable of taking such action, decision or determination and shall forward any communications and documentation to such individual for response or action. Actions, decisions or determinations by the Engineer's Designated Representative on behalf of Engineer shall be done in his or her reasonable business judgment unless express standards or parameters therefor are included in this Contract, in which case, actions taken by the Engineer's Designated Representative shall be in accordance with such express standards or parameters. Any consent, approval, decision or determination hereunder by the Engineer's Designated Representative shall be binding on Engineer. Engineer's Designated

Representative shall have the right to modify, amend and execute Work Authorizations, Supplemental Work Authorizations and Contract Amendments on behalf of Engineer.

ARTICLE 10
PROGRESS EVALUATION

Engineer shall, from time to time during the progress of the Engineering Services, confer with County at County's election. Engineer shall prepare and present such information as may be pertinent and necessary, or as may be reasonably requested by County, in order for County to evaluate features of the Engineering Services. At the request of County or Engineer, conferences shall be provided at Engineer's office, the offices of County, or at other locations designated by County. When requested by County, such conferences shall also include evaluation of the Engineering Services. County may, from time to time, require Engineer to appear and provide information to the Williamson County Commissioners Court.

Should County determine that the progress in Engineering Services does not satisfy an applicable Work Authorization or any Supplemental Work Authorization related thereto, then County shall review same with Engineer to determine corrective action required.

Engineer shall promptly advise County in writing of events which have or may have a significant impact upon the progress of the Engineering Services, including but not limited to the following:

- A. Problems, delays, adverse conditions which may materially affect the ability to meet the objectives of an applicable Work Authorization or any Supplemental Work Authorization related thereto, or preclude the attainment of Project Engineering Services units by established time periods; and such disclosure shall be accompanied by statement of actions taken or contemplated, and County assistance needed to resolve the situation, if any; and
- B. Favorable developments or events which enable meeting goals sooner than anticipated in relation to an applicable Work Authorization's or any Supplemental Work Authorization related thereto.

ARTICLE 11
SUSPENSION

Should County desire to suspend the Engineering Services, but not to terminate this Contract, then such suspension may be effected by County giving Engineer thirty (30) calendar days' verbal notification followed by written confirmation to that effect. Such thirty-day notice may be waived in writing by agreement and signature of both parties. The Engineering Services may be reinstated and resumed in full force and effect within sixty (60) days of receipt of written notice from County to resume the Engineering Services. Such sixty-day (60) notice may be waived in writing by agreement and signature of both parties. If this Contract is suspended for more than thirty (30) days, Engineer shall have the option of terminating this Contract and, in the event, Engineer shall be compensated for all Engineering Services performed and reimbursable expenses incurred, provided such Engineering Services and reimbursable expenses have been previously authorized and approved by County, to the effective date of suspension.

If County suspends the Engineering Services, the contract period as determined in Article 4, and the Work Authorization or any Supplemental Work Authorization related thereto, shall be extended for a time period equal to the suspension period.

County assumes no liability for Engineering Services performed or costs incurred prior to the date authorized by County for Engineer to begin Engineering Services, and/or during periods when Engineering Services is suspended, and/or subsequent to the completion date.

ARTICLE 12
ADDITIONAL ENGINEERING SERVICES

If Engineer forms a reasonable opinion that any work he/she/it has been directed to perform is beyond the overall scope of this Contract, as set forth in **Exhibit B**, and as such constitutes extra work (“Additional Engineering Services”), he/she/it shall promptly notify County in writing. In the event County finds that such work does constitute Additional Engineering Services, County shall so advise Engineer and a written Contract Amendment will be executed between the parties as provided in Article 14. Any increase to the Compensation Cap due to Additional Engineering Services must be set forth in such Contract Amendment. Engineer shall not perform any proposed Additional Engineering Services nor incur any additional costs prior to the execution, by both parties, of a written Contract Amendment. Following the execution of a Contract Amendment that provides for Additional Engineering Services, a written Work Authorization, which sets forth the Additional Engineering Services to be performed, must be executed by the parties. County shall not be responsible for actions by Engineer nor for any costs incurred by Engineer relating to Additional Engineering Services not directly associated with the performance of the Engineering Services authorized in this Contract, by a fully executed Work Authorization or a fully executed Contract Amendment thereto.

ARTICLE 13
CHANGES IN COMPLETED ENGINEERING SERVICES

If County deems it necessary to request changes to previously satisfactorily completed Engineering Services or parts thereof which involve changes to the original Engineering Services or character of Engineering Services under this Contract, then Engineer shall make such revisions as requested and as directed by County. Such revisions shall be considered as Additional Engineering Services and paid for as specified under Article 12.

Engineer shall make revisions to Engineering Services authorized hereunder as are necessary to correct errors appearing therein, when required to do so by County. No additional compensation shall be due for such Engineering Services.

ARTICLE 14
CONTRACT AMENDMENTS

The terms set out in this Contract may be modified by a written fully executed Contract Amendment. Changes and modifications to a fully executed Work Authorization shall be made in the form of a Supplemental Work Authorization. To the extent that such changes or

modifications to a Work Authorization do not also require modifications to the terms of this Contract (i.e. changes to the overall scope of Engineering Services set forth in **Exhibit B**, modification of the Compensation Cap, etc.) a Contract Amendment will not be required.

ARTICLE 15 **USE OF DOCUMENTS**

All documents, including but not limited to drawings, specifications and data or programs stored electronically, (hereinafter referred to as “Engineering Work Products”) prepared by Engineer and its subcontractors/subconsultants are related exclusively to the services described in this Contract and are intended to be used with respect to this Project. However, it is expressly understood and agreed by and between the parties hereto that all of Engineer’s designs under this Contract (including but not limited to tracings, drawings, estimates, specifications, investigations, studies and other documents, completed or partially completed), shall be the property of County to be thereafter used in any lawful manner as County elects. Any such subsequent use made of documents by County shall be at County’s sole risk and without liability to Engineer.

By execution of this Contract and in confirmation of the fee for services to be paid under this Contract, Engineer hereby conveys, transfers and assigns to County all rights under the Federal Copyright Act of 1976 (or any successor copyright statute), as amended, all common law copyrights and all other intellectual property rights acknowledged by law in the Project Designs and work product developed under this Contract. Copies may be retained by Engineer. Engineer shall be liable to County for any loss or damage to any such documents while they are in the possession of or while being worked upon by Engineer or anyone connected with Engineer, including agents, employees, Engineers or subcontractors/subconsultants. All documents so lost or damaged shall be replaced or restored by Engineer without cost to County.

Upon execution of this Contract, Engineer grants to County permission to reproduce Engineer’s work and documents for purposes of constructing, using and maintaining the Project, provided that County shall comply with its obligations, including prompt payment of all sums when due, under this Contract. Engineer shall obtain similar permission from Engineer’s subcontractors/subconsultants consistent with this Contract. If and upon the date Engineer is adjudged in default of this Contract, County is permitted to authorize other similarly credentialed design professionals to reproduce and, where permitted by law, to make changes, corrections or additions to the work and documents for the purposes of completing, using and maintaining the Project.

County shall not assign, delegate, sublicense, pledge or otherwise transfer any permission granted herein to another party without the prior written consent of Engineer. However, County shall be permitted to authorize the contractor, subcontractors and material or equipment suppliers to reproduce applicable portions of the Engineering Work Products appropriate to and for use in the execution of the Work. Submission or distribution of Engineering Work Products to meet official regulatory requirements or for similar purposes in connection with the Project is permitted. Any unauthorized use of the Engineering Work Products shall be at County's sole risk and without liability to Engineer and its Engineers.

Prior to Engineer providing to County any Engineering Work Products in electronic form or County providing to Engineer any electronic data for incorporation into the Engineering Work Products, County and Engineer shall by separate written contract set forth the specific conditions governing the format of such Engineering Work Products or electronic data, including any special limitations not otherwise provided in this Contract. Any electronic files are provided by Engineer for the convenience of County, and use of them is at County's sole risk. In the case of any defects in electronic files or any discrepancies between them and any hardcopy of the same documents prepared by Engineer, the hardcopy shall prevail. Only printed copies of documents conveyed by Engineer shall be relied upon.

Engineer shall have no liability for changes made to the drawings by other engineers subsequent to the completion of the Project. Any such change shall be sealed by the engineer making that change and shall be appropriately marked to reflect what was changed or modified.

ARTICLE 16 **PERSONNEL, EQUIPMENT AND MATERIAL**

Engineer shall furnish and maintain, at its own expense, quarters for the performance of all Engineering Services, and adequate and sufficient personnel and equipment to perform the Engineering Services as required. All employees of Engineer shall have such knowledge and experience as will enable them to perform the duties assigned to them. Any employee of Engineer who, in the reasonable opinion of County, is incompetent or whose conduct becomes detrimental to the Engineering Services shall immediately be removed from association with the Project when so instructed by County. Engineer certifies that it presently has adequate qualified personnel in its employment for performance of the Engineering Services required under this Contract, or will obtain such personnel from sources other than County. Engineer may not change the Project Manager without prior written consent of County.

ARTICLE 17 **SUBCONTRACTING**

Engineer shall not assign, subcontract or transfer any portion of the Engineering Services under this Contract without prior written approval from County. All subcontracts shall include the provisions required in this Contract. No subcontract shall relieve Engineer of any responsibilities under this Contract.

ARTICLE 18 **REVIEW OF ENGINEERING SERVICES**

Engineer's Engineering Services will be reviewed by County under its applicable technical requirements and procedures.

A. Completion. Reports, plans, specifications, and supporting documents shall be submitted by Engineer on or before the dates specified in the applicable Work Authorization or Supplemental Work Authorization related thereto. Upon receipt of same, the submission shall be checked for completion. "Completion" or "Complete" shall be defined as all of the required items, as set out in the applicable Work Authorization, have been included in compliance with the requirements of this Contract. The completeness of any Engineering Services submitted to County shall be determined by County within thirty (30) days of such submittal and County shall notify Engineer in writing within such thirty (30) day period if such Engineering Services have been found to be incomplete. If the submission is Complete, County shall notify Engineer and County's technical review process will begin.

If the submission is not Complete, County shall notify Engineer, who shall perform such professional services as are required to complete the Engineering Services and resubmit it to County. This process shall be repeated until a submission is Complete.

B. Acceptance. County shall review the completed Engineering Services for compliance with this Contract. If necessary, the completed Engineering Services shall be returned to Engineer, who shall perform any required Engineering Services and resubmit it to County. This process shall be repeated until the Engineering Services are Accepted. "Acceptance" or "Accepted" shall mean that in the County's reasonable opinion, substantial compliance with the requirements of this Contract has been achieved.

C. Final Approval. After Acceptance, Engineer shall perform any required modifications, changes, alterations, corrections, redesigns, and additional work necessary to receive Final Approval by the County. "Final Approval" in this sense shall mean formal recognition that the Engineering Services have been fully carried out.

D. Errors and Omissions. After Final Approval, Engineer shall, without additional compensation, perform any work required as a result of Engineer's development of the work which is found to be in error or omission due to Engineer's negligence. However, any work required or occasioned for the convenience of County after Final Approval shall be paid for as Additional Engineering Services.

E. Disputes Over Classifications. In the event of any dispute over the classification of Engineer's Engineering Services as Complete, Accepted, or having attained Final Approved under this Contract, the decision of the County shall be final and binding on Engineer, subject to any civil remedy or determination otherwise available to the parties and deemed appropriate by the parties.

F. County's Reliance on Engineer. ENGINEER'S DUTIES AS SET FORTH HEREIN SHALL AT NO TIME BE IN ANY WAY DIMINISHED BY REASON OF ANY REVIEW, EVALUATION OR APPROVAL BY THE COUNTY NOR SHALL THE ENGINEER BE RELEASED FROM ANY LIABILITY BY REASON OF SUCH REVIEW, EVALUATION OR APPROVAL BY THE COUNTY, IT BEING UNDERSTOOD THAT THE COUNTY AT ALL TIMES IS ULTIMATELY RELYING UPON THE ENGINEER'S SKILL, ABILITY AND KNOWLEDGE IN PERFORMING THE ENGINEERING SERVICES REQUIRED HEREUNDER.

ARTICLE 19
VIOLATION OF CONTRACT TERMS/BREACH OF CONTRACT

Violation of contract terms or breach of contract by Engineer shall be grounds for termination of this Contract, and any increased costs arising from Engineer's default, breach of contract, or violation of contract terms shall be paid by Engineer.

ARTICLE 20
TERMINATION

This Contract may be terminated as set forth below.

- A. By mutual agreement and consent, in writing, of both parties.
- B. By County, by notice in writing to Engineer, as a consequence of failure by Engineer to perform the Engineering Services set forth herein in a satisfactory manner.
- C. By either party, upon the failure of the other party to fulfill its obligations as set forth herein.
- D. By County, for reasons of its own and not subject to the mutual consent of Engineer, upon not less than thirty (30) days' written notice to Engineer.
- E. By satisfactory completion of all Engineering Services and obligations described herein.

Should County terminate this Contract as herein provided, no fees other than fees due and payable at the time of termination plus reimbursable expenses incurred shall thereafter be paid to Engineer. In determining the value of the Engineering Services performed by Engineer prior to termination, County shall be the sole judge. Compensation for Engineering Services at termination will be based on a percentage of the Engineering Services completed at that time. Should County terminate this Contract under Subsection (D) immediately above, then the amount charged during the thirty-day notice period shall not exceed the amount charged during the preceding thirty (30) days.

If Engineer defaults in the performance of this Contract or if County terminates this Contract for fault on the part of Engineer, then County shall give consideration to the actual costs incurred by Engineer in performing the Engineering Services to the date of default, the amount of Engineering Services required which was satisfactorily completed to date of default, the value of the Engineering Services which are usable to County, the cost to County of employing another firm to complete the Engineering Services required and the time required to do so, and other factors which affect the value to County of the Engineering Services performed at the time of default.

The termination of this Contract and payment of an amount in settlement as prescribed above shall extinguish all rights, duties, and obligations of County under this Contract. If the termination of this Contract is due to the failure of Engineer to fulfill his/her/its contractual obligations, then County may take over the Project and prosecute the Engineering Services to

completion. In such case, Engineer shall be liable to County for any additional and reasonable costs incurred by County.

Engineer shall be responsible for the settlement of all contractual and administrative issues arising out of any procurements made by Engineer in support of the Engineering Services under this Contract.

ARTICLE 21
COMPLIANCE WITH LAWS

A. Compliance. Engineer shall comply with all applicable federal, state and local laws, statutes, codes, ordinances, rules and regulations, and the orders and decrees of any court, or administrative bodies or tribunals in any manner affecting the performance of this Contract, including without limitation, minimum/maximum salary and wage statutes and regulations, and licensing laws and regulations. Engineer shall furnish County with satisfactory proof of his/her/its compliance.

Engineer shall further obtain all permits and licenses required in the performance of the Engineering Services contracted for herein.

B. Taxes. Engineer will pay all taxes, if any, required by law arising by virtue of the Engineering Services performed hereunder. County is qualified for exemption pursuant to the provisions of Section 151.309 of the Texas Limited Sales, Excise, and Use Tax Act.

ARTICLE 22
INDEMNIFICATION

ENGINEER AGREES, TO THE FULLEST EXTENT PERMITTED BY LAW, TO INDEMNIFY AND HOLD THE COUNTY HARMLESS FROM AND AGAINST ANY AND ALL LIABILITIES, LOSSES, PENALTIES, JUDGMENTS, CLAIMS, LAWSUITS, DAMAGES, COSTS AND EXPENSES, INCLUDING, BUT NOT LIMITED TO, ATTORNEYS' FEES, ("LOSSES") TO THE EXTENT SUCH LOSSES ARE CAUSED BY OR RESULTS FROM AN NEGLIGENT ACT OR OMISSION, NEGLIGENCE, OR INTENTIONAL TORT COMMITTED BY ENGINEER, ENGINEER'S EMPLOYEES, AGENTS, OR ANY OTHER PERSON OR ENTITY UNDER CONTRACT WITH ENGINEER INCLUDING, WITHOUT LIMITATION, ENGINEER'S SUBCONSULTANTS, OR ANY OTHER ENTITY OVER WHICH ENGINEER EXERCISES CONTROL.

ENGINEER FURTHER AGREES, TO THE FULLEST EXTENT PERMITTED BY LAW, TO INDEMNIFY AND HOLD THE COUNTY HARMLESS FROM ANY AND ALL LIABILITIES, LOSSES, PENALTIES, JUDGMENTS, CLAIMS, LAWSUITS, DAMAGES, COSTS AND EXPENSES, INCLUDING, BUT NOT LIMITED TO, ATTORNEYS' FEES, ("LOSSES") TO THE EXTENT SUCH LOSSES ARE CAUSED BY OR RESULTS FROM ENGINEER'S FAILURE TO PAY ENGINEER'S EMPLOYEES, SUBCONTRACTORS, SUBCONSULTANTS, OR SUPPLIERS, IN CONNECTION WITH ANY OF THE WORK PERFORMED OR TO BE PERFORMED UNDER THIS CONTRACT BY ENGINEER.

ENGINEER FURTHER AGREES TO INDEMNIFY AND HOLD THE COUNTY HARMLESS FROM ANY AND ALL LIABILITIES, LOSSES, PENALTIES, CLAIMS, LAWSUITS, DAMAGES, COSTS AND EXPENSES,

INCLUDING, BUT NOT LIMITED TO, ATTORNEYS' FEES, ("LOSSES") TO THE EXTENT SUCH LOSSES ARE CAUSED BY OR RESULTS FROM THE INFRINGEMENT OF ANY INTELLECTUAL PROPERTY ARISING OUT OF THE USE OF ANY PLANS, DESIGN, DRAWINGS, OR SPECIFICATIONS FURNISHED BY ENGINEER IN THE PERFORMANCE OF THIS CONTRACT.

THE LIMITS OF INSURANCE REQUIRED IN THIS CONTRACT AND/OR THE CONTRACT DOCUMENTS SHALL NOT LIMIT ENGINEER'S OBLIGATIONS UNDER THIS SECTION. THE TERMS AND CONDITIONS CONTAINED IN THIS SECTION SHALL SURVIVE THE TERMINATION OF THE CONTRACT AND/OR CONTRACT DOCUMENTS OR THE SUSPENSION OF THE WORK HEREUNDER. TO THE EXTENT THAT ANY LIABILITIES, PENALTIES, DEMANDS, CLAIMS, LAWSUITS, LOSSES, DAMAGES, COSTS AND EXPENSES ARE CAUSED IN PART BY THE ACTS OF THE COUNTY OR THIRD PARTIES FOR WHOM ENGINEER IS NOT LEGALLY LIABLE, ENGINEER'S OBLIGATIONS SHALL BE IN PROPORTION TO ENGINEER'S FAULT. THE OBLIGATIONS HEREIN SHALL ALSO EXTEND TO ANY ACTIONS BY THE COUNTY TO ENFORCE THIS INDEMNITY OBLIGATION.

IN THE EVENT THAT CONTRACTORS INITIATE LITIGATION AGAINST THE COUNTY IN WHICH THE CONTRACTOR ALLEGES DAMAGES AS A RESULT OF ANY NEGLIGENT ACTS, ERRORS OR OMISSIONS OF ENGINEER, ITS EMPLOYEES, AGENTS, SUBCONTRACTORS, SUBCONSULTANTS, OR SUPPLIERS, OR OTHER ENTITIES OVER WHICH ENGINEER EXERCISES CONTROL, INCLUDING, BUT NOT LIMITED TO, DEFECTS, ERRORS, OR OMISSIONS, THEN THE COUNTY SHALL HAVE THE RIGHT TO JOIN ENGINEER IN ANY SUCH PROCEEDINGS AT THE COUNTY'S COST. ENGINEER SHALL ALSO HOLD THE COUNTY HARMLESS AND INDEMNIFY THE COUNTY TO THE EXTENT THAT ENGINEER, ANY OF ITS EMPLOYEES, AGENTS, SUBCONTRACTORS, SUBCONSULTANTS, OR SUPPLIERS, OR OTHER ENTITIES OVER WHICH ENGINEER EXERCISES CONTROL, CAUSED SUCH DAMAGES TO CONTRACTOR, INCLUDING ANY AND ALL COSTS AND ATTORNEYS' FEES INCURRED BY THE COUNTY IN CONNECTION WITH THE DEFENSE OF ANY CLAIMS WHERE ENGINEER, ITS EMPLOYEES, AGENTS, SUBCONTRACTORS, SUBCONSULTANTS, OR SUPPLIERS, OR OTHER ENTITIES OVER WHICH ENGINEER EXERCISES CONTROL, ARE ADJUDICATED AT FAULT.

ARTICLE 23

ENGINEER'S RESPONSIBILITIES

Engineer shall be responsible for the accuracy of his/her/its Engineering Services and shall promptly make necessary revisions or corrections to its work product resulting from errors, omissions, or negligent acts, and same shall be done without compensation. County shall determine Engineer's responsibilities for all questions arising from design errors and/or omissions, subject to the dispute resolution provisions of Article 33. Engineer shall not be relieved of responsibility for subsequent correction of any such errors or omissions in its work product, or for clarification of any ambiguities until after the construction phase of the Project has been completed.

ARTICLE 24

ENGINEER'S SEAL

The responsible engineer shall sign, seal and date all appropriate engineering submissions to County in accordance with the Texas Engineering Practice Act and the rules of the State Board of Registration for Professional Engineers.

ARTICLE 25 **INSURANCE**

Engineer must comply with the following insurance requirements at all times during this Contract:

A. Coverage Limits. Engineer, at Engineer's sole cost, shall purchase and maintain during the entire term while this Contract is in effect the following insurance:

1. Worker's Compensation in accordance with statutory requirements.
2. Commercial General Liability Insurance with a combined minimum Bodily Injury and Property Damage limits of \$1,000,000.00 per occurrence and \$2,000,000.00 in the aggregate.
3. Automobile Liability Insurance for all owned, non-owned, and hired vehicles with combined minimum limits for Bodily Injury and Property Damage limits of \$500,000.00 per occurrence and \$1,000,000.00 in the aggregate.
4. Professional Liability Errors and Omissions Insurance in the amount of \$2,000,000.00 per claim.

B. Additional Insureds; Waiver of Subrogation. County, its directors, officers and employees shall be added as additional insureds under policies listed under (2) and (3) above, and on those policies where County, its directors, officers and employees are additional insureds, such insurance shall be primary and any insurance maintained by County shall be excess and not contribute with it. Such policies shall also include waivers of subrogation in favor of County.

C. Premiums and Deductible. Engineer shall be responsible for payment of premiums for all of the insurance coverages required under this section. Engineer further agrees that for each claim, suit or action made against insurance provided hereunder, with respect to all matters for which the Engineer is responsible hereunder, Engineer shall be solely responsible for all deductibles and self-insured retentions. Any deductibles or self-insured retentions over \$50,000 in the Engineer's insurance must be declared and approved in writing by County in advance.

D. Commencement of Work. Engineer shall not commence any field work under this Contract until he/she/it has obtained all required insurance and such insurance has been approved by County. As further set out below, Engineer shall not allow any subcontractor/subconsultant(s) to commence work to be performed in connection with this Contract until all required insurance has been obtained and approved and such approval shall not be unreasonably withheld. Approval of the insurance by County shall not relieve or decrease the liability of Engineer hereunder.

E. Insurance Company Rating. The required insurance must be written by a company approved to do business in the State or Texas with a financial standing of at least an A-rating, as reflected in Best's insurance ratings or by a similar rating system recognized within the insurance industry at the time the policy is issued.

F. Certification of Coverage. Engineer shall furnish County with a certification of coverage issued by the insurer. Engineer shall not cause any insurance to be canceled nor permit any insurance to lapse. **In addition to any other notification requires set forth hereunder, Engineer shall also notify County, within twenty-four (24) hours of receipt, of any notices of expiration, cancellation, non-renewal, or material change in coverage it receives from its insurer.**

G. No Arbitration. It is the intention of the County and agreed to and hereby acknowledged by the Engineer, that no provision of this Contract shall be construed to require the County to submit to mandatory arbitration in the settlement of any claim, cause of action or dispute, except as specifically required in direct connection with an insurance claim or threat of claim under an insurance policy required hereunder or as may be required by law or a court of law with jurisdiction over the provisions of this Contract.

H. Subcontractor/Subconsultant's Insurance. Without limiting any of the other obligations or liabilities of Engineer, Engineer shall require each subcontractor/subconsultant performing work under this Contract (to the extent a subcontractor/subconsultant is allowed by County) to maintain during the term of this Contract, at the subcontractor/subconsultant's own expense, the same stipulated minimum insurance required in this Article above, including the required provisions and additional policy conditions as shown below in this Article.

Engineer shall obtain and monitor the certificates of insurance from each subcontractor/subconsultant in order to assure compliance with the insurance requirements. Engineer must retain the certificates of insurance for the duration of this Contract, and shall have the responsibility of enforcing these insurance requirements among its subcontractor/subconsultants. County shall be entitled, upon request and without expense, to receive copies of these certificates of insurance.

I. Insurance Policy Endorsements. Each insurance policy shall include the following conditions by endorsement to the policy:

1. County shall be notified thirty (30) days prior to the expiration, cancellation, non-renewal or any material change in coverage, and such notice thereof shall be given to County by certified mail to:

Williamson County Auditor
c/o: Pam Navarrette
710 Main Street, Suite 301
Georgetown, Texas 78626

With copy to: Williamson County Dept. of Infrastructure

Attn: Director of Road & Bridge
3151 SE Inner Loop, Suite B
Georgetown, Texas 78626

2. The policy clause "Other Insurance" shall not apply to any insurance coverage currently held by County, to any such future coverage, or to County's Self-Insured Retentions of whatever nature.

J. Cost of Insurance. The cost of all insurance required herein to be secured and maintained by Engineer shall be borne solely by Engineer, with certificates of insurance evidencing such minimum coverage in force to be filed with County. Such Certificates of Insurance are evidenced as **Exhibit F** herein entitled "Certificates of Insurance."

ARTICLE 26 **COPYRIGHTS**

County shall have the royalty-free, nonexclusive and irrevocable right to reproduce, publish or otherwise use, and to authorize others to use, any reports developed by Engineer for governmental purposes.

ARTICLE 27 **SUCCESSORS AND ASSIGNS**

This Contract shall be binding upon and inure to the benefit of the parties hereto, their successors, lawful assigns, and legal representatives. Engineer may not assign, sublet or transfer any interest in this Contract, in whole or in part, by operation of law or otherwise, without obtaining the prior written consent of County.

ARTICLE 28 **SEVERABILITY**

In the event any one or more of the provisions contained in this Contract shall for any reason be held to be invalid, illegal or unenforceable in any respect, then such invalidity, illegality or unenforceability shall not affect any other provision thereof and this Contract shall be construed as if such invalid, illegal or unenforceable provision had never been contained herein.

ARTICLE 29 **PRIOR AGREEMENTS SUPERSEDED**

This Contract constitutes the sole agreement of the parties hereto, and supersedes any prior understandings or written or oral contracts between the parties respecting the subject matter defined herein. This Contract may only be amended or supplemented by mutual agreement of the parties hereto in writing.

ARTICLE 30 **ENGINEER'S ACCOUNTING RECORDS**

Engineer agrees to maintain, for a period of three (3) years after final payment under this Contract, detailed records identifying each individual performing the Engineering Services, the date or dates the services were performed, the applicable hourly rates, the total amount billed for each individual and the total amount billed for all persons, records of reimbursable costs and expenses of other providers and provide such other details as may be requested by the County Auditor for verification purposes. Engineer agrees that County or its duly authorized representatives shall, until the expiration of three (3) years after final payment under this Contract, have access to and the right to examine and photocopy any and all books, documents, papers and records of Engineer which are directly pertinent to the services to be performed under this Contract for the purposes of making audits, examinations, excerpts, and transcriptions. Engineer further agrees that County shall have access during normal working hours to all necessary Engineer facilities and shall be provided adequate and appropriate work space in order to conduct audits in compliance with the provisions of this section. County shall give Engineer reasonable advance notice of intended audits.

ARTICLE 31
NOTICES

All notices to either party by the other required under this Contract shall be personally delivered or mailed to such party at the following respective addresses:

County: Williamson County Judge
710 Main Street, Suite 101
Georgetown, Texas 78626

With copy to: Williamson County Dept. of Infrastructure
Attn: Director of Road & Bridge
3151 SE Inner Loop, Suite B
Georgetown, Texas 78626

and to: Office of General Counsel
Williamson County
710 Main Street, Suite 102
Georgetown, Texas 78626

Engineer: Doucet & Associates, Inc.
Duke G. Altman, P.E.
7401B Hwy 71 West, Suite 160
Austin, TX 78735

ARTICLE 32
GENERAL PROVISIONS

A. Time is of the Essence. Subject to Article 3 hereof, Engineer understands and agrees that time is of the essence and that any failure of Engineer to complete the Engineering Services for each phase of this Contract within the agreed work schedule set out in the applicable Work Authorization may constitute a material breach of this Contract. Engineer shall be fully responsible for his/her/its delays or for failures to use his/her/its reasonable efforts in accordance with the terms of this Contract and the Engineer's standard of performance as defined herein. Where damage is caused to County due to Engineer's negligent failure to perform County may accordingly withhold, to the extent of such damage, Engineer's payments hereunder without waiver of any of County's additional legal rights or remedies.

B. Force Majeure. Neither County nor Engineer shall be deemed in violation of this Contract if prevented from performing any of their obligations hereunder by reasons for which they are not responsible or circumstances beyond their control. However, notice of such impediment or delay in performance must be timely given, and all reasonable efforts undertaken to mitigate its effects.

C. Enforcement and Venue. This Contract shall be enforceable in Georgetown, Williamson County, Texas, and if legal action is necessary by either party with respect to the enforcement of any or all of the terms or conditions herein, exclusive venue for same shall lie in Williamson County, Texas. This Contract shall be governed by and construed in accordance with the laws and court decisions of the State of Texas excluding, however, its choice of law rules.

D. Standard of Performance. The standard of care for all professional engineering, consulting and related services performed or furnished by Engineer and its employees under this Contract will be the care and skill ordinarily used by members of Engineer's profession practicing under the same or similar circumstances at the same time and in the same locality.

E. Opinion of Probable Cost. Any opinions of probable Project cost or probable construction cost provided by Engineer are made on the basis of information available to Engineer and on the basis of Engineer's experience and qualifications and represents its judgment as an experienced and qualified professional engineer. However, since Engineer has no control over the cost of labor, materials, equipment or services furnished by others, or over the contractor(s') methods of determining prices, or over competitive bidding or market conditions, Engineer does not guarantee that proposals, bids or actual Project or construction cost will not vary from opinions of probable cost Engineer prepares.

F. Opinions and Determinations. Where the terms of this Contract provide for action to be based upon opinion, judgment, approval, review, or determination of either party hereto, such terms are not intended to be and shall never be construed as permitting such opinion, judgment, approval, review, or determination to be arbitrary, capricious, or unreasonable.

G. Reports of Accidents. Within 24 hours after Engineer becomes aware of the

occurrence of any accident or other event which results in, or might result in, injury to the person or property of any third person (other than an employee of the Engineer), whether or not it results from or involves any action or failure to act by the Engineer or any employee or agent of the Engineer and which arises in any manner from the performance of this Contract, the Engineer shall send a written report of such accident or other event to the County, setting forth a full and concise statement of the facts pertaining thereto. The Engineer shall also immediately send the County a copy of any summons, subpoena, notice, or other documents served upon the Engineer, its agents, employees, or representatives, or received by it or them, in connection with any matter before any court arising in any manner from the Engineer's performance of work under this Contract.

H. Gender, Number and Headings. Words of any gender used in this Contract shall be held and construed to include any other gender, and words in the singular number shall be held to include the plural, unless the context otherwise requires. The headings and section numbers are for convenience only and shall not be considered in interpreting or construing this Contract.

I. Construction. Each party hereto acknowledges that it and its counsel have reviewed this Contract and that the normal rules of construction are not applicable and there will be no presumption that any ambiguities will be resolved against the drafting party in the interpretation of this Contract.

J. Independent Contractor Relationship. Both parties hereto, in the performance of this Contract, shall act in an individual capacity and not as agents, employees, partners, joint ventures or associates of one another. The employees or agents of one party shall not be deemed or construed to be the employees or agents of the other party for any purposes whatsoever.

K. No Waiver of Immunities. Nothing in this Contract shall be deemed to waive, modify or amend any legal defense available at law or in equity to County, its past or present officers, employees, or agents or employees, nor to create any legal rights or claim on behalf of any third party. County does not waive, modify, or alter to any extent whatsoever the availability of the defense of governmental immunity under the laws of the State of Texas and of the United States.

L. Texas Public Information Act. To the extent, if any, that any provision in this Contract is in conflict with Tex. Gov't Code 552.001 et seq., as amended (the "Public Information Act"), the same shall be of no force or effect. Furthermore, it is expressly understood and agreed that County, its officers and employees may request advice, decisions and opinions of the Attorney General of the State of Texas in regard to the application of the Public Information Act to any items or data furnished to County as to whether or not the same are available to the public. It is further understood that County's officers and employees shall have the right to rely on the advice, decisions and opinions of the Attorney General, and that County, its officers and employees shall have no liability or obligation to any party hereto for the disclosure to the public, or to any person or persons, of any items or data furnished to County by a party hereto, in reliance of any advice, decision or opinion of the Attorney General of the State of Texas.

M. Governing Terms and Conditions. If there is an irreconcilable conflict between the terms and conditions set forth in this Contract or any Contract Amendment and the terms and

conditions set forth in any Exhibit, Appendix, Work Authorization or Supplemental Work Authorization to this Contract, the terms and conditions set forth in this Contract or any Contract Amendment shall control over the terms and conditions set forth in any Exhibit, Appendix, Work Authorization or Supplemental Work Authorization to this Contract.

N. Meaning of Day. For purposes of this Contract, all references to a “day” or “days” shall mean a calendar day or calendar days.

O. Appropriation of Funds by County. County believes it has sufficient funds currently available and authorized for expenditure to finance the costs of this Contract. Engineer understands and agrees that County’s payment of amounts under this Contract is contingent on the County receiving appropriations or other expenditure authority sufficient to allow the County, in the exercise of reasonable administrative discretion, to continue to make payments under this Contract. It is further understood and agreed by Engineer that County shall have the right to terminate this Contract at the end of any County fiscal year if the governing body of County does not appropriate sufficient funds as determined by County’s budget for the fiscal year in question. County may effect such termination by giving written notice of termination to Engineer.

P. Termination of Work Authorization. Should it be determined that the progress in the production of Engineer’s services and work does not satisfy the requirements of the approved Work Authorization as provided by Exhibit "C", attached hereto, the County shall review the approved Work Authorization with the Engineer to determine the corrective action needed, including potential termination of such Work Authorization by Williamson County. Additionally, if an approved Work Authorization has not been completed by the end of the applicable County fiscal year under this contract and the Williamson County Commissioners Court does not provide for funding through its budgetary oversight for the subsequent County fiscal year, Williamson County reserves the right to terminate such Work Authorization at its discretion.

ARTICLE 33 **DISPUTE RESOLUTION**

Except as otherwise specifically set forth herein, County and Engineer shall work together in good faith to resolve any controversy, dispute or claim between them which arises out of or relates to this Contract, whether stated in tort, contract, statute, claim for benefits, bad faith, professional liability or otherwise ("Claim"). If the parties are unable to resolve the Claim within thirty (30) days following the date in which one party sent written notice of the Claim to the other party, and if a party wishes to pursue the Claim, such Claim shall be addressed through non-binding mediation. A single mediator engaged in the practice of law, who is knowledgeable about subject matter of this Contract, shall be selected by agreement of the parties and serve as the mediator. Any mediation under this Contract shall be conducted in Williamson County, Texas. The mediator’s fees shall be borne equally between the parties. Such non-binding mediation is a condition precedent to seeking redress in a court of competent jurisdiction, but this provision shall not preclude either party from filing a lawsuit in a court of competent jurisdiction prior to completing a mediation if necessary to preserve the statute of limitations, in which case such lawsuit shall be stayed pending completion of the mediation process contemplated herein. This provision shall survive the termination of the Contract.

ARTICLE 34
EQUAL OPPORTUNITY IN EMPLOYMENT

During the performance of this Contract and to the extent the Project is a federally funded project, Engineer, for itself, its assignees and successors in interest agrees as follows:

A. Compliance with Regulations. The Engineer shall comply with the Regulations relative to nondiscrimination in Federally-assisted programs of the Department of Transportation (hereinafter, "DOT") Title 49, Code of Federal Regulations, Part 21, as they may be amended from time to time, (hereinafter referred to as the Regulations), which are herein incorporated by reference and made a part of this Contract.

B. Nondiscrimination. The Engineer, with regard to the work performed by it during the Contract, shall not discriminate on the grounds of race, color, or national origin in the selection and retention of subcontractors/subconsultants, including procurements of materials and leases of equipment. The Engineer shall not participate either directly or indirectly in the discrimination prohibited by section 21.5 of the Regulations, including employment practices when the contract covers a program set forth in Appendix B of the Regulations.

C. Solicitations for Subcontracts, Including Procurements of Materials and Equipment. In all solicitations either by competitive bidding or negotiation made by the Engineer for work to be performed under a subcontract, including procurements of materials or leases of equipment, each potential subcontractor/subconsultant or supplier shall be notified by the Engineer of the Engineer's obligations under this Contract and the Regulations relative to nondiscrimination on the grounds of race, color, or national origin.

D. Information and Reports. The Engineer shall provide all information and reports required by the Regulations or directives issued pursuant thereto, and shall permit access to its books, records, accounts, other sources of information, and its facilities as may be determined by the County (referred to in this Article as the "Recipient") or the Texas Department of Transportation to be pertinent to ascertain compliance with such Regulations, orders and instructions. Where any information required of a contractor is in the exclusive possession of another who fails or refuses to furnish this information the Engineer shall so certify to the Recipient, or the Texas Department of Transportation as appropriate, and shall set forth what efforts it has made to obtain the information.

E. Sanctions for Noncompliance. In the event of the Engineer's noncompliance with the nondiscrimination provisions of this contract, the Recipient shall impose such contract sanctions as it or the Texas Department of Transportation may determine to be appropriate, including, but not limited to:

1. withholding of payments to the Engineer under the contract until the Engineer complies, and/or;
2. cancellation, termination or suspension of the Contract, in whole or in part.

F. Incorporation of Provisions. The Engineer shall include the provisions of Subsections (A) through (F) above in every subcontract, including procurements of materials and leases of equipment, unless exempt by the Regulations, or directives issued pursuant thereto. The Engineer shall take such action with respect to any subcontract or procurement as the Recipient or the Texas Department of Transportation may direct as a means of enforcing such provisions including sanctions for non-compliance: Provided, however, that, in the event a contractor becomes involved in, or is threatened with, litigation with a subcontractor/subconsultant or supplier as a result of such direction, the Engineer may request the Recipient to enter into such litigation to protect the interests of the Recipient, and, in addition, the Engineer may request the United States to enter into such litigation to protect the interests of the United States.

SIGNATORY WARRANTY

The undersigned signatory for Engineer hereby represents and warrants that the signatory is an officer of the organization for which he/she has executed this Contract and that he/she has full and complete authority to enter into this Contract on behalf of the firm. The above-stated representations and warranties are made for the purpose of inducing County to enter into this Contract.

IN WITNESS WHEREOF, County has caused this Contract to be signed in its name by its duly authorized County Judge, as has Engineer, signing by and through its duly authorized representative(s), thereby binding the parties hereto, their successors, assigns and representatives for the faithful and full performance of the terms and provisions hereof, to be effective as of the date of the last party's execution below. NO OFFICIAL, EMPLOYEE, AGENT, OR REPRESENTATIVE OF THE COUNTY HAS ANY AUTHORITY, EITHER EXPRESS OR IMPLIED, TO AMEND, TERMINATE OR MODIFY THIS CONTRACT, EXCEPT PURSUANT TO SUCH EXPRESS AUTHORITY AS MAY BE GRANTED BY THE WILLIAMSON COUNTY COMMISSIONERS COURT.

COUNTY

WILLIAMSON COUNTY, TEXAS

By: _____
Dan A. Gattis, County Judge

Date: _____, 20____

ENGINEER

Doucet & Associates, Inc.

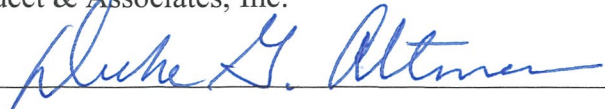
By 

Printed Name: Duke G. Altman, P.E.

Title: Principal

Date: February 21, 2018

SUBSCRIBED and sworn to before me the undersigned authority by Duke Altman
_____ the Principal _____ of **ENGINEER**, on behalf of said firm.

Helen K Lee

Notary Public in and for the
State of Texas



My commission expires: 8/31/2019

LIST OF EXHIBITS ATTACHED

- (1) **Exhibit A** Debarment Certification
- (2) **Exhibit B** Engineering Services
- (3) **Exhibit C** Work Authorization
- (4) **Exhibit D** Rate Schedule
- (5) **Exhibit E** Williamson County Vendor Reimbursement Policy
- (6) **Exhibit F** Certificates of Insurance

**EXHIBIT A
DEBARMENT CERTIFICATION**

STATE OF TEXAS

§

COUNTY OF WILLIAMSON

§

§

I, the undersigned, being duly sworn or under penalty of perjury under the laws of the United States and the State of Texas, certifies that Engineer and its principals:

- (a) Are not presently debarred, suspended, proposed for debarment, declared ineligible or voluntarily excluded from covered transactions by any federal department or agency;
- (b) Have not within a three-year period preceding this proposal been convicted of or had a civil judgment rendered against them for commission of fraud or a criminal offense in connection with obtaining, attempting to obtain, or performing a public* transaction or contract under a public transaction; violation of federal or state antitrust statutes or commission of embezzlement, theft, forgery, bribery, falsification or destruction of records, making false statements, or receiving stolen property;
- (c) Are not presently indicted for or otherwise criminally or civilly charged by a governmental entity* with commission of any of the offenses enumerated in paragraph (1)(b) of this certification;
- (d) Have not within a three-year period preceding this application/proposal had one or more public transactions* terminated for cause or default; and
- (e) Have not been disciplined or issued a formal reprimand by any State agency for professional accreditation within the past three years.

Doucet & Associates, Inc.

Name of Firm



Signature of Certifying Official

Amy Doucet

Printed Name of Certifying Official

President

Title of Certifying Official

February 19th, 20 18

Date

(2) Where the PROVIDER is unable to certify to any of the statements in this certification, such PROVIDER shall attach an explanation to this certification.

* federal, state, or local

SUBSCRIBED and sworn to before me the undersigned authority by Amy Doucet
the President of Doucet & Associates, Inc. on behalf of
said firm.



Helen K Lee
Notary Public in and for the
State of Texas

My commission expires: 8-31-2019

EXHIBIT B

ENGINEERING SERVICES

PROJECT DESCRIPTION

The engineer will collect data and perform detailed hydrologic and hydraulic analyses to evaluate existing and future flooding conditions along Smith Branch and tributaries, with particular emphasis around the Williamson County Juvenile Justice Center (JJC). Based on these analyses and engineering judgement, the engineer will recommend mitigation alternative designs with cost estimates to reduce the risk of flooding to structures along Smith Branch.

EXHIBIT C

WORK AUTHORIZATION

(To Be Completed and Executed After Contract Execution)

WORK AUTHORIZATION NO. _____

PROJECT: _____

This Work Authorization is made pursuant to the terms and conditions of the Williamson County Contract for Engineering Services, being dated _____, 20____ and entered into by and between Williamson County, Texas, a political subdivision of the State of Texas, (the "County") and _____ (the "Engineer").

Part 1. The Engineer will provide the following Engineering Services set forth in Attachment "B" of this Work Authorization.

Part 2. The maximum amount payable for services under this Work Authorization without modification is _____.

Part 3. Payment to the Engineer for the services established under this Work Authorization shall be made in accordance with the Contract.

Part 4. This Work Authorization shall become effective on the date of final acceptance and full execution of the parties hereto and shall terminate on _____, 20____. The Engineering Services set forth in Attachment "B" of this Work Authorization shall be fully completed on or before said date unless extended by a Supplemental Work Authorization.

Part 5. This Work Authorization does not waive the parties' responsibilities and obligations provided under the Contract.

Part 6. County believes it has sufficient funds currently available and authorized for expenditure to finance the costs of this Work Authorization. Engineer understands and agrees that County's payment of amounts under this Work Authorization is contingent on the County receiving appropriations or other expenditure authority sufficient to allow the County, in the exercise of reasonable administrative discretion, to continue to make payments under this Contract. It is further understood and agreed by Engineer that County shall have the right to terminate this Contract at the end of any County fiscal year if the governing body of County does not appropriate sufficient funds as determined by County's budget for the fiscal year in question. County may effect such termination by giving written notice of termination to Engineer.

Part 7. This Work Authorization is hereby accepted and acknowledged below.

EXECUTED this ____ day of _____, 20__.

ENGINEER:

[Insert Company Name HERE]

By: _____
Signature

Printed Name

Title

COUNTY:

Williamson County, Texas

By: _____
Signature

Printed Name

Title

LIST OF ATTACHMENTS

Attachment A - Services to be Provided by County

Attachment B - Services to be Provided by Engineer

Attachment C - Work Schedule

Attachment D - Fee Schedule

EXHIBIT D

RATE SCHEDULE

Doucet & Associates 2018 Fee Schedule (effective 01/01/2018)

Personnel	Hourly Fee	Personnel	Hourly Fee
Principal Engineer (PE)	\$225.00	Principal Surveyor (RPLS)	\$215.00
Senior Project Manager	\$200.00	Project Manager (RPLS)	\$175.00
Project Manager	\$185.00	Project Surveyor (RPLS)	\$145.00
Senior Project Engineer (PE)	\$168.00	Project Coordinator	\$130.00
Project Engineer	\$145.00	Survey Specialist (Sr. Svy Tech)	\$120.00
Engineer Associate II	\$115.00	Survey Technician	\$100.00
Engineer Associate I	\$ 95.00	GIS Specialist	\$120.00
Sr. Construction Technician	\$139.00	GIS Technician	\$100.00
Construction Manager	\$100.00	LiDAR Specialist	\$120.00
Program Manager	\$100.00	LiDAR Technician	\$100.00
Sr. Civil Technician	\$130.00	Aerial Mapping Specialist	\$120.00
Civil Technician	\$115.00	Aerial Mapping Technician	\$100.00
Assistant Civil Technician	\$105.00	Plat Coordinator	\$115.00
CADD Operator II	\$ 90.00	One-Person Field Crew	\$110.00
CADD Operator I	\$ 80.00	Two-Person Field Crew	\$160.00
Senior Planner (AICP)	\$155.00	Three-Person Field Crew	\$190.00
Project Planner	\$140.00	Four-Person Field Crew	\$220.00
Staff Planner	\$110.00	Party Chief-Time Basis	\$100.00
Planning Technician	\$ 95.00	Division Administrator	\$ 90.00
		LiDAR Scanner	\$100.00/hr
Sr. Operations Assistant	\$ 85.00	Drone	\$600.00/hr
Operations Assistant	\$ 65.00	Ground Targets	\$20/ea
Administrative Assistant	\$ 65.00	Concrete Monuments	\$250/ea
		ATV/Boat/Sonar	\$100/day
Expert Witness (research, depositions, testimony, with a 4-hour minimum for court appearances)	\$430.00	Mileage	Current IRS Rate

D&A reserves the right to periodically adjust our fee schedule.

Reimbursable Expenses

Direct non-salary expenses incurred and not applicable to general overhead are billed at cost. A list of reimbursable expenses will be provided but physical backup for reimbursable expenses will not be included with invoices unless requested to do so.

Reimbursable Expenses include, but are not limited to, the following:

Travel and lodging, including out of town transportation by Doucet and Scheibe vehicles at standard rates; mail, delivery, courier and express charges; legal and accounting fees (including attorney's fees charged by Doucet's attorney for review or negotiation of any certificates or similar documents requested by Client or a lender doing business with Client); in-house reproduction costs (to be charged at prevailing commercial rates); subconsultants; photographs; environmental fees; charges incurred in stopping or resuming work in accordance with this Agreement; use or rental of special equipment or instruments and other direct non-salary expenses necessary to complete the contract.

Scheibe Consulting, LLC Billing Rates

(01/01/2018)

Principal - \$215/hr

Senior Engineer - \$185/hr

Project Engineer - \$145/hr

Engineer - \$125/hr

EIT II - \$110/hr

EIT I - \$ 95/hr

Admin. - \$ 65/hr

CPI Rate Adjustments: Rates will remain firm for the initial first year of the Contract and such rates shall be deemed the “Initial Base Rates”. Engineer must request rate adjustments, in writing, at least thirty (30) days prior to each annual anniversary date of the Contract and any rate changes will take effect on the first day following the prior year. If Engineer fails to request a CPI rate adjustment, as set forth herein, the adjustment will be effective thirty (30) days after the County receives Engineer’s written request. No retroactive rate adjustments will be allowed.

Price adjustments will be made in accordance with changes in the U.S. Department of Labor Consumer Price Index (CPI-U) for All Urban Consumers, All Items, South Region (Base 1982-84 = 100).

The rate adjustment will be determined by multiplying the Initial Base Rates by a fraction, the numerator of which is the index number for most recently released index before each annual anniversary date of the Contract and the denominator of which is the index number for the first month of the Contract (the index number for the month in which the Contract was originally executed). If the products are greater than the Initial Base Rates, County will pay the greater amounts as the rates during the successive year until the next rate adjustment. Rates for each successive year will never be less than the Initial Base Rates.

EXHIBIT E

Williamson County Vendor Reimbursement Policy

The purpose of this Williamson County Vendor Reimbursement Policy (“Policy”) is to provide clear guidelines to vendors on Williamson County’s expectations and requirements regarding allowable reimbursable expenditures and required backup. The Policy will also minimize conflicts related to invoice payments and define non-reimbursable items. This Policy is considered a guideline and is not a contract.

This Policy may be altered, deleted or amended, at any time and without prior notice to vendors, by action of the Williamson County Commissioners Court. Unenforceable provisions of this Policy, as imposed by applicable law, regulations, or judicial decisions, shall be deemed to be deleted. Any revisions to this Policy will be distributed to all current vendors doing business with the County.

1. Invoices and Affidavits

- 1.1 Invoices must adequately describe the goods or services provided to County and include all required backup (i.e. reimbursable expenses, mileage log, timesheets, receipts detailing expenses incurred etc.) that is in a form acceptable to the Williamson County Auditor. Invoices that do not adequately describe the goods or services provided to County or contain backup that is satisfactory to the Williamson County Auditor will be returned to vendor for revisions and the provision above relating to invoice errors resolved in favor of the County shall control as to the required actions of vendor and when such invoice must be paid by the County.
- 1.2 In the event an invoice includes charges based upon hourly billing rates for services or any other rates based upon the amount of time worked by an individual or individuals in performing services, whether the charges are being billed directly to the County or whether they are the basis of invoices from subcontractors for which the vendor seeks reimbursement from the County, the charges shall be accompanied by an affidavit signed by an officer or principal of the vendor certifying that the work was performed, it was authorized by the County and that all information contained in the invoice that is being submitted is true and correct.
- 1.3 Upon County’s request, vendor must submit all bills paid affidavits wherein vendor must swear and affirm that vendor has paid each of its subcontractors, laborers, suppliers and material in full for all labor and materials provided to vendor for or in connection with services and work performed for County and, further, vendor must swear and affirm that vendor is not aware of any unpaid bills, claims, demands, or causes of action by any of its subcontractors, laborers, suppliers, or material for or in connection with the furnishing of labor or materials, or both, for services and work performed for County.

2. Travel Reimbursement

- 2.1 The County will only cover costs associated with travel on vendors outside a 50 mile radius from Williamson County, Texas.
- 2.2 The County will only cover costs associated with travel as documented work for County. If a vendor is also doing business for another client, the travel costs must be split in proportion to the amount of work actually performed for County and the other client. The only allowable travel expense will be for the specific days worked for Williamson County.
- 2.3 No advance payments will be made to vendor for travel expenditures. The travel expenditure may only be reimbursed after the expenditure/trip has already occurred and vendor has provided the Williamson County Auditor with all necessary and required backup.
- 2.4 Vendors must submit all travel reimbursement requests on each employee in full. Specifically, a travel reimbursement request must include all related travel reimbursement expenses relating to a particular trip for which vendor seeks reimbursement. Partial travel reimbursement requests will not be accepted (i.e. vendor should not submit hotel and mileage one month then the next month submit rental car and airfare). If the travel reimbursement appears incomplete, the invoice will be sent back to the vendor to be submitted when all information is ready to submit in full.
- 2.5 Reimbursement for transportation costs will be at the most reasonable means of transportation (i.e.: airline costs will be reimbursed for coach rate, rental car costs will only be reimbursed if rental car travel was most reasonable means of travel as compared to travel by air).
- 2.6 The County will not be responsible for, nor will the County reimburse additional charges due to personal preference or personal convenience of individual traveling.
- 2.7 The County will not reimburse airfare costs if airfare costs were higher than costs of mileage reimbursement.
- 2.8 Additional expenses associated with travel that is extended to save costs (i.e. Saturday night stay) may be reimbursed if costs of airfare would be less than the cost of additional expenses (lodging, meals, car rental, mileage) if the trip had not been extended. Documentation satisfactory to the Williamson County Auditor will be required to justify expenditure.
- 2.9 County will only reimburse travel expense to necessary personnel of the vendor (i.e. no spouse, friends or family members).
- 2.10 Except as otherwise set forth herein, a vendor must provide a paid receipt for all expenses. If a receipt cannot be obtained, a written sworn statement of the expense from the vendor may be substituted for the receipt.
- 2.11 Sales tax for meals and hotel stays are the only sales taxes that will be reimbursed. Sales tax on goods purchased will not be reimbursed. A sales tax exemption form is available from the Williamson County Auditor's Office upon request.
- 2.12 The County will not pay for any late charges on reimbursable items. It is the responsibility of the vendor to pay the invoice first and seek reimbursement from the County.

3. Meals

- 3.1 Meal reimbursements are limited to a maximum of \$50.00 per day on overnight travel. On day travel (travel that does not require an overnight stay), meal reimbursements are limited to a maximum of \$20.00 per day. The travel must be outside the Williamson County, Texas line by a 50 mile radius.
- 3.2 Receipts are required on meal reimbursement amounts up to the maximum per day amount stated for overnight or day travel. If receipts are not presented, the vendor can request per diem (per diem limits refer to 3.2). However, a vendor cannot combine per diem and meal receipts. Only one method shall be allowed.
- 3.3 Meals are reimbursable only for vendors who do not have the necessary personnel located within a 50 mile radius of Williamson County, Texas that are capable of carrying the vendor's obligations to County. Meals will not be reimbursed to vendors who are located within a 50 mile radius of Williamson County, Texas.
- 3.4 County will not reimburse for alcoholic beverages.
- 3.5 Tips are reimbursable but must be reasonable to limitation of meal allowance
- 3.6 No meals purchased for entertainment purposes will be allowed.
- 3.7 Meal reimbursement must be substantiated with a hotel receipt.

4. Lodging

- 4.1 Hotel accommodations require an itemized hotel folio as a receipt. The lodging receipt should include name of the motel/hotel, number of occupant(s), goods or services for each individual charge (room rental, food, tax, etc.) and the name of the occupant(s). Credit card receipts or any other form of receipt are not acceptable.
- 4.2 Vendors will be reimbursed for a single room rate charge plus any applicable tax. If a single room is not available, the vendor must provide documentation to prove that a single room was not available in order to justify the expense over and above the single room rate. A vendor may also be required to provide additional documentation if a particular room rate appears to be excessive.
- 4.3 Personal telephone charges, whether local or long distance, will not be reimbursed.

5. Airfare

- 5.1 The County will only reimburse up to a coach price fare for air travel.
- 5.2 The County will exclude any additional charges due to personal preference or personal convenience of the individual traveling (i.e. early bird check in, seat preference charges, airline upgrades, etc. will not be an allowable reimbursement)
- 5.3 Air travel expenses must be supported with receipt copy of an airline ticket or an itinerary with actual ticket price paid. If tickets are purchased through a website, vendor must submit a copy of the webpage showing the ticket price if no paper ticket was issued.

- 5.4 Cancellation and/or change flight fees may be reimbursed by the County but vendor must provide the Williamson County Auditor with documentation in writing from a County department head providing authorization for the change.
- 5.5 The County will not reimburse vendor for tickets purchased with frequent flyer miles.

6. Car Rental

- 6.1 Vendors that must travel may rent a car at their destination when it is less expensive than other transportation such as taxis, airport shuttles or public transportation such as buses or subways.
- 6.2 Cars rented must be economy or mid-size. Luxury vehicle rentals will not be reimbursed. Any rental costs over and above the cost of a mid-size rental will be adjusted.
- 6.3 Vendors will be reimbursed for rental cars if the rental car cost would have been less than the mileage reimbursement cost (based on the distance from vendor's point of origin to Williamson County, Texas) had the vendor driven vendor's car.
- 6.4 Vendors must return a car rental with appropriate fuel levels as required by rental agreement to avoid the car rental company from adding fuel charges.
- 6.5 Rental agreement and credit card receipt must be provided to County as back up for the request for reimbursement.
- 6.6 Insurance purchased when renting vehicle may also be reimbursed.
- 6.7 Car Rental optional extras such as GPS, roadside assistance, and administrative fees on Tolls will not be reimbursed.

7. Personal Car Usage

- 7.1 Personal vehicle usage will be reimbursed in an amount equal to the standard mileage rate allowed by the IRS.
- 7.2 Per code of Federal Regulations, Title 26, Subtitle A, Chapter 1, Subchapter B, Part IX, Section 274(d), all expense reimbursement requests must include the following:
 - 7.2.1.1 Date
 - 7.2.1.2 Destination
 - 7.2.1.3 Purpose
 - 7.2.1.4 Name of traveler(s)
 - 7.2.1.5 Correspondence that verifies business purpose of the expense
- 7.3 The mileage for a personal vehicle must document the date, location of travel to/from, number of miles traveled and purpose of trip.
- 7.4 Mileage will be reimbursed on the basis of the most commonly used route.
- 7.5 Reimbursement for mileage shall not exceed the cost of a round trip coach airfare.
- 7.6 Reimbursement for mileage shall be prohibited between place of residence and usual place of work.
- 7.7 Mileage should be calculated from employee's regular place of work or their residence, whichever is the shorter distance when traveling to a meeting or traveling to Williamson County, Texas for vendors who are located outside of Williamson County, Texas by at least a 50 mile radius.

- 7.8 When more than one person travels in same vehicle, only one person may claim mileage reimbursement.
- 7.9 Tolls, if reasonable, are reimbursable. Receipts are required for reimbursement. If a receipt is not obtainable, then written documentation of expense must be submitted for reimbursement (administrative fees on Tolls will not be reimbursed).
- 7.10 Parking fees, if reasonable are reimbursable for meetings and hotel stays. For vendors who contract with a third party for visitor parking at vendor's place of business, Williamson County will not reimburse a vendor based on a percentage of its contracted visitor parking fees. Rather, Williamson County will reimburse Vendor for visitor parking on an individual basis for each time a visitor uses Vendor's visitor parking. Receipts are required for reimbursement. If a receipt is not obtainable, then written documentation of expense must be submitted for reimbursement.
- 7.11 Operating and maintenance expenses as well as other personal expenses, such as parking tickets, traffic violations, and car repairs and collision damage are not reimbursable.

8. Other Expenses

- 8.1 Taxi fare, bus tickets, conference registrations, parking, etc. must have a proper original receipt.

9. Repayment of Nonreimbursable Expense.

Vendors must, upon demand, immediately repay County for all inappropriately reimbursed expenses whenever an audit or subsequent review of any expense reimbursement documentation finds that such expense was reimbursed contrary to these guidelines and this Policy. Williamson County reserves the right to retain any amounts that are due or that become due to a vendor in order to collect any inappropriately reimbursed expenses that a vendor was paid.

10. Non-Reimbursable Expenses

In addition to the non-reimbursable items set forth above in this Policy, the following is a non-exhaustive list of expenses that will not be reimbursed by Williamson County:

- 10.1 Alcoholic beverages/tobacco products
- 10.2 Personal phone calls
- 10.3 Laundry service
- 10.4 Valet service (excludes hotel valet)
- 10.5 Movie rentals
- 10.6 Damage to personal items
- 10.7 Flowers/plants
- 10.8 Greeting cards
- 10.9 Fines and/or penalties
- 10.10 Entertainment, personal clothing, personal sundries and services
- 10.11 Transportation/mileage to places of entertainment or similar personal activities
- 10.12 Upgrades to airfare, hotel and/or car rental

- 10.13 Airport parking above the most affordable rate available
- 10.14 Excessive weight baggage fees or cost associated with more than two airline bags
- 10.15 Auto repairs
- 10.16 Babysitter fees, kennel costs, pet or house-sitting fees
- 10.17 Saunas, massages or exercise facilities
- 10.18 Credit card delinquency fees or service fees
- 10.19 Doctor bills, prescription and other medical services
- 10.20 Hand tools
- 10.21 Safety Equipment (hard hats, safety vests, etc.)
- 10.22 Office Supplies
- 10.23 Lifetime memberships to any association
- 10.24 Donations to other entities
- 10.25 Any items that could be construed as campaigning
- 10.26 Community outreach items exceeding \$2 per item
- 10.27 Technology Fees
- 10.28 Sales tax on goods purchased
- 10.29 Any other expenses which Williamson County deems, in its sole discretion, to be inappropriate or unnecessary expenditures.

EXHIBIT F

CERTIFICATES OF INSURANCE

ATTACHED BEHIND THIS PAGE

THIS CERTIFICATE IS ISSUED AS A MATTER OF INFORMATION ONLY AND CONFERS NO RIGHTS UPON THE CERTIFICATE HOLDER. THIS CERTIFICATE DOES NOT AFFIRMATIVELY OR NEGATIVELY AMEND, EXTEND OR ALTER THE COVERAGE AFFORDED BY THE POLICIES BELOW. THIS CERTIFICATE OF INSURANCE DOES NOT CONSTITUTE A CONTRACT BETWEEN THE ISSUING INSURER(S), AUTHORIZED REPRESENTATIVE OR PRODUCER, AND THE CERTIFICATE HOLDER.

IMPORTANT: If the certificate holder is an ADDITIONAL INSURED, the policy(ies) must have ADDITIONAL INSURED provisions or be endorsed. If SUBROGATION IS WAIVED, subject to the terms and conditions of the policy, certain policies may require an endorsement. A statement on this certificate does not confer any rights to the certificate holder in lieu of such endorsement(s).

PRODUCER USI Southwest Austin/SCL 7600-B N. Capital of TX Hwy #200 Austin, TX 78731 512 451-7555	CONTACT NAME: Debra Wylie PHONE (A/C, No, Ext): 512-651-4159	FAX (A/C, No): 610-537-2782	
	E-MAIL ADDRESS: debra.wylie@usi.com		
INSURED Doucet & Associates, Inc. 7401B Hwy. 71 West #160 Austin, TX 78735	INSURER(S) AFFORDING COVERAGE		NAIC #
	INSURER A : American Casualty Company of Reading PA		20427
	INSURER B : Continental Casualty Company		20443
	INSURER C : Atlantic Specialty Insurance Company		27154
	INSURER D : American Casualty Co of Reading, PA		20427
	INSURER E :		20427

COVERAGES **CERTIFICATE NUMBER:** **REVISION NUMBER:**

THIS IS TO CERTIFY THAT THE POLICIES OF INSURANCE LISTED BELOW HAVE BEEN ISSUED TO THE INSURED NAMED ABOVE FOR THE POLICY PERIOD INDICATED. NOTWITHSTANDING ANY REQUIREMENT, TERM OR CONDITION OF ANY CONTRACT OR OTHER DOCUMENT WITH RESPECT TO WHICH THIS CERTIFICATE MAY BE ISSUED OR MAY PERTAIN, THE INSURANCE AFFORDED BY THE POLICIES DESCRIBED HEREIN IS SUBJECT TO ALL THE TERMS, EXCLUSIONS AND CONDITIONS OF SUCH POLICIES. LIMITS SHOWN MAY HAVE BEEN REDUCED BY PAID CLAIMS.

INSR LTR	TYPE OF INSURANCE	ADDL INSR	SUBR WVD	POLICY NUMBER	POLICY EFF (MM/DD/YYYY)	POLICY EXP (MM/DD/YYYY)	LIMITS
A	<input checked="" type="checkbox"/> COMMERCIAL GENERAL LIABILITY <input type="checkbox"/> CLAIMS-MADE <input checked="" type="checkbox"/> OCCUR Contractual Liability GEN'L AGGREGATE LIMIT APPLIES PER: <input type="checkbox"/> POLICY <input checked="" type="checkbox"/> PRO-JECT <input type="checkbox"/> LOC OTHER:		X	B2087785945	10/17/2017	10/17/2018	EACH OCCURRENCE \$2,000,000 DAMAGE TO RENTED PREMISES (Ea occurrence) \$300,000 MED EXP (Any one person) \$10,000 PERSONAL & ADV INJURY \$2,000,000 GENERAL AGGREGATE \$4,000,000 PRODUCTS - COMP/OP AGG \$4,000,000 \$
D	AUTOMOBILE LIABILITY <input checked="" type="checkbox"/> ANY AUTO OWNED AUTOS ONLY <input type="checkbox"/> SCHEDULED AUTOS <input checked="" type="checkbox"/> HIRED AUTOS ONLY <input checked="" type="checkbox"/> NON-OWNED AUTOS ONLY			B2087935018	10/17/2017	10/17/2018	COMBINED SINGLE LIMIT (Ea accident) \$1,000,000 BODILY INJURY (Per person) \$ BODILY INJURY (Per accident) \$ PROPERTY DAMAGE (Per accident) \$ \$
B	<input checked="" type="checkbox"/> UMBRELLA LIAB <input checked="" type="checkbox"/> OCCUR <input type="checkbox"/> EXCESS LIAB <input type="checkbox"/> CLAIMS-MADE DED <input checked="" type="checkbox"/> RETENTION \$10000			B2087786089	10/17/2017	10/17/2018	EACH OCCURRENCE \$4,000,000 AGGREGATE \$4,000,000 \$
	WORKERS COMPENSATION AND EMPLOYERS' LIABILITY ANY PROPRIETOR/PARTNER/EXECUTIVE OFFICER/MEMBER EXCLUDED? <input type="checkbox"/> Y/N (Mandatory in NH) If yes, describe under DESCRIPTION OF OPERATIONS below		N/A				PER STATUTE OTH-ER E.L. EACH ACCIDENT \$ E.L. DISEASE - EA EMPLOYEE \$ E.L. DISEASE - POLICY LIMIT \$
C	Professional Liab Claims Made & Reported			DPL724317 Retro:06/19/1992	10/17/2017	10/17/2018	\$5,000,000 per claim \$5,000,000 annl aggr.

DESCRIPTION OF OPERATIONS / LOCATIONS / VEHICLES (ACORD 101, Additional Remarks Schedule, may be attached if more space is required)
RE: Project: Smith Branch Flood Control and Drainage Engineering Services.

Professional Land Surveyors, Inc.
 Accusurve, Inc.
 Earth Quest, Inc.
 (See Attached Descriptions)

CERTIFICATE HOLDER Williamson County Auditor Attn: Pat Navarrette 710 Main Street, Suite 301 Georgetown, TX 78626	CANCELLATION SHOULD ANY OF THE ABOVE DESCRIBED POLICIES BE CANCELLED BEFORE THE EXPIRATION DATE THEREOF, NOTICE WILL BE DELIVERED IN ACCORDANCE WITH THE POLICY PROVISIONS. AUTHORIZED REPRESENTATIVE 
--	--

DESCRIPTIONS (Continued from Page 1)

The General Liability and Auto policies includes a blanket automatic Additional Insured endorsement that provides Additional Insured and a Blanket Waiver of Subrogation status to the Certificate holder, only when there is a written contract or written agreement between the named insured and the certificate holder that requires such status, and only with regard to the above referenced on behalf of the named insured.

The General Liability policy contains a special endorsement with "Primary and Noncontributory" wording with respect to the sole negligence of the named insured, when required by written contract. The General Liability policy contains a Per Project Aggregate Limit Endorsement. The Umbrella policy follows form.



CERTIFICATE OF LIABILITY INSURANCE

DATE (MM/DD/YYYY)

2/20/2018

Acct#: 1180481

THIS CERTIFICATE IS ISSUED AS A MATTER OF INFORMATION ONLY AND CONFERS NO RIGHTS UPON THE CERTIFICATE HOLDER. THIS CERTIFICATE DOES NOT AFFIRMATIVELY OR NEGATIVELY AMEND, EXTEND OR ALTER THE COVERAGE AFFORDED BY THE POLICIES BELOW. THIS CERTIFICATE OF INSURANCE DOES NOT CONSTITUTE A CONTRACT BETWEEN THE ISSUING INSURER(S), AUTHORIZED REPRESENTATIVE OR PRODUCER, AND THE CERTIFICATE HOLDER.

IMPORTANT: If the certificate holder is an ADDITIONAL INSURED, the policy(ies) must be endorsed. If SUBROGATION IS WAIVED, subject to the terms and conditions of the policy, certain policies may require an endorsement. A statement on this certificate does not confer rights to the certificate holder in lieu of such endorsement(s).

PRODUCER Lockton Companies, LLC 5847 San Felipe, Suite 320 Houston, TX 77057	CONTACT NAME: 888-828-8365
	PHONE (A/C, No, Ext): _____ FAX (A/C, No): _____
	E-MAIL ADDRESS: _____
INSURER(S) AFFORDING COVERAGE	
INSURER A : Indemnity Insurance Co. of North America	NAIC # 43575
INSURED Insuperity, Inc. 19001 Crescent Springs Drive Kingwood, TX 77339 *SEE BELOW	INSURER B :
	INSURER C :
	INSURER D :
	INSURER E :
	INSURER F :

COVERAGES **CERTIFICATE NUMBER:** **REVISION NUMBER:**

THIS IS TO CERTIFY THAT THE POLICIES OF INSURANCE LISTED BELOW HAVE BEEN ISSUED TO THE INSURED NAMED ABOVE FOR THE POLICY PERIOD INDICATED. NOTWITHSTANDING ANY REQUIREMENT, TERM OR CONDITION OF ANY CONTRACT OR OTHER DOCUMENT WITH RESPECT TO WHICH THIS CERTIFICATE MAY BE ISSUED OR MAY PERTAIN, THE INSURANCE AFFORDED BY THE POLICIES DESCRIBED HEREIN IS SUBJECT TO ALL THE TERMS, EXCLUSIONS AND CONDITIONS OF SUCH POLICIES. LIMITS SHOWN MAY HAVE BEEN REDUCED BY PAID CLAIMS.

INSR LTR	TYPE OF INSURANCE	ADDL INSD	SUBR WVD	POLICY NUMBER	POLICY EFF (MM/DD/YYYY)	POLICY EXP (MM/DD/YYYY)	LIMITS
	COMMERCIAL GENERAL LIABILITY <input type="checkbox"/> CLAIMS-MADE <input type="checkbox"/> OCCUR GEN'L AGGREGATE LIMIT APPLIES PER: <input type="checkbox"/> POLICY <input type="checkbox"/> PRO-JECT <input type="checkbox"/> LOC OTHER: _____						EACH OCCURRENCE \$ DAMAGE TO RENTED PREMISES (Ea occurrence) \$ MED EXP (Any one person) \$ PERSONAL & ADV INJURY \$ GENERAL AGGREGATE \$ PRODUCTS - COMP/OP AGG \$ \$
	AUTOMOBILE LIABILITY <input type="checkbox"/> ANY AUTO <input type="checkbox"/> ALL OWNED AUTOS <input type="checkbox"/> SCHEDULED AUTOS <input type="checkbox"/> HIRED AUTOS <input type="checkbox"/> NON-OWNED AUTOS						COMBINED SINGLE LIMIT (Ea accident) \$ BODILY INJURY (Per person) \$ BODILY INJURY (Per accident) \$ PROPERTY DAMAGE (Per accident) \$ \$
	UMBRELLA LIAB <input type="checkbox"/> OCCUR EXCESS LIAB <input type="checkbox"/> CLAIMS-MADE DED RETENTION \$						EACH OCCURRENCE \$ AGGREGATE \$ \$
A	WORKERS COMPENSATION AND EMPLOYERS' LIABILITY ANY PROPRIETOR/PARTNER/EXECUTIVE OFFICER/MEMBER EXCLUDED? (Mandatory in NH) <input type="checkbox"/> Y / N If yes, describe under DESCRIPTION OF OPERATIONS below	N/A	X	C64630945	10/1/2017	10/1/2018	<input checked="" type="checkbox"/> PER STATUTE <input type="checkbox"/> OTH-ER E.L. EACH ACCIDENT \$ 1,000,000 E.L. DISEASE - EA EMPLOYEE \$ 1,000,000 E.L. DISEASE - POLICY LIMIT \$ 1,000,000

DESCRIPTION OF OPERATIONS / LOCATIONS / VEHICLES (ACORD 101, Additional Remarks Schedule, may be attached if more space is required)

DOUCET & ASSOCIATES, INC. (2913700) IS INCLUDED AS A NAMED INSURED THROUGH ENDORSEMENT.
 Smith Branch Flood Control and Drainage Engineering Services
 WAIVER OF SUBROGATION IN FAVOR OF Williamson County Auditor WHEN REQUIRED BY WRITTEN CONTRACT.
 ALL STATES EXCEPT OH, ND, WY AND WA

CERTIFICATE HOLDER

WILLIAMSON COUNTY AUDITOR
 PAM NAVARRETTE
 710 MAIN STREET, SUITE 301
 GEORGETOWN, TX 78626

CANCELLATION

SHOULD ANY OF THE ABOVE DESCRIBED POLICIES BE CANCELLED BEFORE THE EXPIRATION DATE THEREOF, NOTICE WILL BE DELIVERED IN ACCORDANCE WITH THE POLICY PROVISIONS.

AUTHORIZED REPRESENTATIVE

Workers' Compensation and Employers' Liability Policy

Named Insured Insperity Inc. DOUCET & ASSOCIATES, INC.	Endorsement Number
	Policy Number Symbol: RWC Number: C64630945
Policy Period 10/1/2017 TO 10/1/2018	Effective Date of Endorsement 10/1/2017
Issued By (Name of Insurance Company) Indemnity Insurance Co. of North America	
Insert the policy number. The remainder of the information is to be completed only when this endorsement is issued subsequent to the preparation of the policy.	

ALTERNATE EMPLOYER ENDORSEMENT - PART ONE COVERAGE ONLY

This endorsement applies only with respect to bodily injury to your employees while in the course of special or temporary employment by the alternate employer in the state named in the Schedule. Part One (Workers Compensation Insurance) will apply as though the alternate employer is insured.

Under Part One (Workers Compensation Insurance) we will reimburse the alternate employer for the benefits required by the workers compensation law if we are not permitted to pay the benefits directly to the persons entitled to them.

Part Two (Employers Liability Insurance) will not apply to the alternate employer and no coverage will be provided for any such liability under this Endorsement.

The insurance afforded by this endorsement is not intended to satisfy the alternate employer's duty to secure its obligations under the workers compensation law. We will not file evidence of this insurance on behalf of the alternate employer with any government agency.

We will not ask any other insurer of the alternate employer to share with us a loss covered by this endorsement.

Premium will be charged for your employees while in the course of special or temporary employment by the alternate employer.

The policy may be canceled according to its terms without sending notice to the alternate employer.

Part Four (Your Duties if Injury Occurs) applies to you and the alternate employer. The alternate employer will recognize our right to defend under Part One and our right to inspect under Part Six.

Schedule

Alternate Employer
Williamson County Auditor

Address
710 Main Street, Suite
301
Georgetown, TX 78626

State of Special or Temporary Employment

This endorsement is not applicable in AK, CT, FL, MA, MN, MO, NC, NJ, TN, WI



Authorized Representative

Workers' Compensation and Employers' Liability Policy

Named Insured
Insperity Inc. DOUCET & ASSOCIATES, INC.

Endorsement Number

Policy Number
Symbol: RWC Number: **C64630945**

Policy Period
10/1/2017 TO 10/1/2018

Effective Date of Endorsement
10/1/2017

Issued By (Name of the Insurance Company)
Indemnity Insurance Co. of North America

Insert the policy number. The remainder of the information is to be completed only when this endorsement is issued subsequent to the preparation of the policy.

TEXAS NOTICE OF MATERIAL CHANGE ENDORSEMENT

This endorsement applies only to the insurance provided by the policy because Texas is shown in item 3.A. of the Information Page.

In the event of cancelation or other material change of the policy, we will mail advance notice to the person or organization named in the Schedule. The number of days advance notices is shown in the Schedule.

This endorsement shall not operate directly or indirectly to benefit anyone not named in the Schedule.

Schedule

1. Number of Days Advance Notice
30

2. Notice will be mailed to:
Williamson County Auditor
710 Main Street, Suite 301
Georgetown, TX 78626



Authorized Agent

Workers' Compensation and Employers' Liability Policy

Named Insured Insperity Inc. DOUCET & ASSOCIATES, INC.	Endorsement Number
	Policy Number Symbol: RWC Number: C64630945
Policy Period 10/1/2017 TO 10/1/2018	Effective Date of Endorsement 10/1/2017
Issued By (Name of Insurance Company) Indemnity Insurance Co. of North America	
Insert the policy number. The remainder of the information is to be completed only when this endorsement is issued subsequent to the preparation of the policy.	

TEXAS WAIVER OF OUR RIGHT TO RECOVER FROM OTHERS ENDORSEMENT

This endorsement applies only to the insurance provided by the policy because Texas is shown in item 3.A. of the Information Page.

We have the right to recover our payments from anyone liable for an injury covered by this policy. We will not enforce our right against the person or organization named in the Schedule, but this waiver applies only with respect to bodily injury arising out of the operations described in the Schedule, where you are required by a written contract to obtain this waiver from us.

This endorsement shall not operate directly or indirectly to benefit anyone not named in the Schedule. The premium for this endorsement is shown in the Schedule.

Schedule

1. (X) Specific Waiver
Name of person or organization:
Williamson County Auditor
710 Main Street, Suite 301

Georgetown, TX 78626
- () Blanket Waiver
Any person or organization for whom the Named Insured has agreed by written contract to furnish this waiver.
2. Operations:
Smith Branch Flood Control and Drainage Engineering Services
3. Premium:
The premium charge for this endorsement shall be INCLUDED percent of the premium developed on payroll in connection with work performed for the above person(s) or organization(s) arising out of the operations described.
4. Advance Premium: INCLUDED



Authorized Representative

Commissioners Court - Regular Session

30.

Meeting Date: 02/27/2018

Doucet Associates WA 1 Smith Branch Flood Control and Drainage Engineering Services

Submitted For: Robert Daigh

Submitted By: Sarah Ramos, Infrastructure

Department: Infrastructure

Division: Road & Bridge

Agenda Category: Consent

Information

Agenda Item

Discuss, consider and take appropriate action on Work Authorization No. 1 in the amount of \$114,250.00 to expire on September 30, 2018 under Williamson County Contract for Engineering Services between Doucet & Associates, Inc. and Williamson County dated February 27, 2018 for Smith Branch Flood Control and Drainage Engineering Services - Williamson County Juvenile Justice Center.

Background

Fiscal Impact

From/To	Acct No.	Description	Amount
---------	----------	-------------	--------

Attachments

WA 1 - Williamson County Juvenile Justice Center

Form Review

Inbox

County Judge Exec Asst.
Form Started By: Sarah Ramos
Final Approval Date: 02/22/2018

Reviewed By

Wendy Coco

Date

02/22/2018 09:27 AM
Started On: 02/21/2018 03:50 PM

WORK AUTHORIZATION NO. 1

PROJECT: Smith Branch Flood Control and Drainage Engineering Services – Williamson County Juvenile Justice Center

This Work Authorization is made pursuant to the terms and conditions of the Williamson County Contract for Engineering Services, being dated _____ and entered into by and between Williamson County, Texas, a political subdivision of the State of Texas, (the "County") and Doucet & Associates, Inc. (the "Engineer").

Part 1. The Engineer will provide the following Engineering Services set forth in Attachment "B" of this Work Authorization.

Part 2. The maximum amount payable for services under this Work Authorization without modification is \$114,250.00.

Part 3. Payment to the Engineer for the services established under this Work Authorization shall be made in accordance with the Contract.

Part 4. This Work Authorization shall become effective on the date of final acceptance and full execution of the parties hereto and shall terminate on September 30, 2018. The Engineering Services set forth in Attachment "B" of this Work Authorization shall be fully completed on or before said date unless extended by a Supplemental Work Authorization.

Part 5. This Work Authorization does not waive the parties' responsibilities and obligations provided under the Contract.

Part 6. County believes it has sufficient funds currently available and authorized for expenditure to finance the costs of this Work Authorization. Engineer understands and agrees that County's payment of amounts under this Work Authorization is contingent on the County receiving appropriations or other expenditure authority sufficient to allow the County, in the exercise of reasonable administrative discretion, to continue to make payments under this Contract. It is further understood and agreed by Engineer that County shall have the right to terminate this Contract at the end of any County fiscal year if the governing body of County does not appropriate sufficient funds as determined by County's budget for the fiscal year in question. County may effect such termination by giving written notice of termination to Engineer.

Part 7. This Work Authorization is hereby accepted and acknowledged below.

EXECUTED this ____ day of _____, 20__.

ENGINEER:

Doucet & Associates, Inc.

By: *Duke G. Altman*
Signature

Duke G. Altman
Printed Name

Principal
Title

COUNTY:

Williamson County, Texas

By: _____
Signature

Printed Name

Title

LIST OF ATTACHMENTS

Attachment A - Services to be Provided by County

Attachment B - Services to be Provided by Engineer

Attachment C - Work Schedule

Attachment D - Fee Schedule

Attachment A - Services to be Provided by County

Williamson County will provide a Project Manager and any requested data that is in the County's control.

Attachment B - Services to be Provided by Engineer

The proposed scope of services is presented in the following work tasks which will result in a PER-level evaluation of flooding conditions in the JJC's vicinity.

- Field Surveying
- Project Meetings
- Preliminary H&H Modeling
- Preliminary Alternative Analysis
- Preliminary Engineering Report
- Refined H&H Modeling
- Refined Alternative Analyses
- Refined Engineering Report
- Grant Opportunities

Following is an explanation of each service for the presently proposed work:

1. Field Surveying – This task will include refined field topographic surveying for the Juvenile Justice Center, a portion of Maple St. ROW, and select channel cross-sections in proximity to the project area including the Zone A tributary along the Maple Street ROW. Will prepare a topographic survey of the area specified on *Wilco Juvenile Justice Center Survey Limits*, dated 2/7/18. Ground survey will be limited to one cross-section extending from the west building corner of the main facility out approximately 1,200' perpendicular and centered on the nearby creek crossing within the survey limits, periodic limited cross-sections in heavily vegetated areas, 100' square limited topo measurements centered along the Maple St. ROW bisecting the survey limits at the creek crossing, utility manholes covers, existing drainage culvert flowlines as encountered during time of survey, various spot elevations in vegetative areas and various spot elevations on hard surfaces throughout the survey limits for use in county-wide LiDAR validation.

The topographic survey will be prepared based on LIDAR point cloud RMSE reporting compared against ground-surveyed validation measurements and will incorporate topographic measurements to generate 1-foot contours. The survey will be performed in accordance with TSPS Standards for a Category 6 Condition II Topographic survey and will be based on NAD 83 (2011) using NAVD88 vertical datum. Deliverables will include Civil3D .dwg file and .XML export of the prepared digital terrain model. Survey will be scheduled to be delivered 12 business days from receipt of the signed proposal. Client is to coordinate right-of-entry access prior to issuance of notice to proceed and provide County-wide LiDAR dataset tiles respective to the survey limits. This proposal includes one field mobilization for ground surveying activity. Subsequent mobilizations for additional ground survey requests can be performed on a supplemental hourly as-needed basis. *Additional survey data may be necessary in future final design efforts, once design recommendations are made.*

2. Project Meetings – Our staff will attend meetings with Williamson County and the City of Georgetown during the project. This task assumes a total of six meetings with Williamson County, two meetings with City of Georgetown, and internal team meetings during the course of this project. If additional meetings are needed, then additional services may be required.
3. Preliminary H&H Modeling - This task effort will specifically utilize the H&H modeling recently developed for Smith Branch in the above-referenced FPPS. Since this modeling will be performed on a short timeframe, the Task 1 (Field Surveying) above in close proximity to the Juvenile Justice Center will not be available and not used. Existing as well as ultimate watershed development conditions will be considered. The modeling/analyses will include the Zone A tributary along Maple St. ROW. Modeling/analyses will focus on identifying the potential flooding risk associated with those two waterways only. Existing and ultimate watershed development 100-yr and 500-yr flood risks will be identified. In addition to the design storm rainfall amounts typically used in the Georgetown area, this analysis will additionally consider the design storm rainfall amounts associated with the preliminary NOAA Atlas 14 precipitation frequency estimates.
4. Preliminary Alternative Analysis – This task will include preliminary/general alternative solution analyses for the reduction of Smith Branch and the Zone A tributary (parallels the Maple Street ROW) potential flooding sources to the JJC. The goal is to have the JJC facilities (existing building finished floor elevations) to be outside of the ultimate 500-year floodplain with one foot of freeboard (excluding any underground facilities that would have to be flood proofed). Alternatives may include (but are not limited to):
 - Channel Improvements to Smith Branch, coupled with a general estimate of needed upstream regional detention to mitigate any loss of floodplain storage due to the channel improvements including the elimination of flow constrictions/bottlenecks;
 - Regional detention upgradient of Maple St. ROW embankment, coupled with improvements to this ROW embankment and Smith Branch flow opening;
 - Levee or floodwall improvements along Smith Branch, possibly coupled with sump areas and/or an internal swale outfalling downstream;
 - Levee or floodwall improvements along the Zone A tributary; and

This task will also include preliminary cost estimates and a map generally locating improvements areas.

5. Preliminary Engineering Memo – This task constitutes the development of a preliminary engineering memo to document the analyses, alternative solutions, and recommendations.
6. Refined H&H Modeling – This effort will include refined H&H modeling using the surveying information outlined above in Task 1 (Field Surveying) above in close proximity to the Juvenile Justice Center. Existing as well as ultimate watershed development conditions will be considered. This effort will specifically focus on refinements to the recently developed Smith Branch model (the modeling used in the preliminary H&H modeling above). Additionally, modeling/analyses will include the Zone A tributary along Maple Street ROW as well as additional small channels within, and adjacent to, the Juvenile Justice Center’s property. Modeling/analyses will focus on identifying

all potential sources of flood risk to this facility and mapping of the existing and ultimate watershed development 100-yr and 500-yr flood risks. In addition to the design storm rainfall amounts typically used in the Georgetown area, this analysis will additionally consider the design storm rainfall amounts associated with the preliminary NOAA Atlas 14 precipitation frequency estimates.

7. Refined Alternative Analysis – This task will include an alternative solution analyses for reduction of all significant potential flooding sources to this facility. Alternatives may include (but are not limited to):
 - Channel Improvements to Smith Branch, coupled with enough upstream regional detention to mitigate any loss of floodplain storage due to the channel improvements;
 - Regional detention upgradient of Maple St. ROW embankment, coupled with improvements to this ROW embankment and Smith Branch flow opening;
 - Levee or floodwall improvements along Smith Branch, possibly coupled with sump areas and/or an internal swale outfalling downstream;
 - Levee or floodwall improvements along the Zone A tributary; and
 - On-site, or near site, channel improvements, diversions, or detention to mitigate on-site sources of flood risk.
 - Protection of any important underground spaces (e.g. basements), facilities, equipment, etc. will also be developed.

This task will also include preliminary cost estimates and schematic layout for each alternative recommended.

8. Refined Engineering Report – This task constitutes the development of a refined engineering report to document the analyses, alternative solutions, recommendations, and any additional effort needed.
9. Grant Opportunities – Grant opportunities to study and/or implement the needed flood control solutions will be investigated. Recommendations will be provided along with the requirements and effort needed to obtain such grants.

ASSUMPTIONS

1. Reimbursables - Printing, reproduction, and other non-labor charges that are directly related to this project will be billed at cost. In-house printing charges will be based on competitive rates of local reproduction companies.
2. Services excluded from this proposal are, but not limited to, structural design (including Site Retaining Walls, embankments, foundations, breakaway wall design, and anchoring analysis); Geotechnical Investigations; Pavement Design; easement designation; OSSF (Septic) Design; Civil Site design services; construction staking; Permit Fees; SWPPP; Zoning; Site Electrical Design; Site Landscape Design; Architectural Elevations; Traffic Impact Analysis (TIA); FEMA CLOMR/LOMR Submittal; environmental assessments including endangered species investigation, wetland determination, archeological investigation, 404 Permitting, and Phase 1 ESAs; and unanticipated engineering services associated with issues that may arise during construction. Should any of these services be desired or required, an additional scope and fee proposal may be necessary.

3. All permit, license, inspection, testing fees, etc., shall be the responsibility of the Owner or Client and are not included in this agreement.
4. Should the Owner request changes to the above defined SCOPE OF SERVICES after an agreement is developed or if additional services are requested, the additional work shall be billed on a time and materials basis. An estimate of additional costs will be provided and approved prior to proceeding with the additional project work.
5. The fees associated with this proposal do not include fees to the City, County, TCEQ, USACE, FEMA, or other review or permitting authorities.
6. Once our project report and/or concept layouts are reviewed and all comments addressed, further modifications to the document will be considered additional services.

Figure 1 - Wilco Juvenile Justice Center Survey Limits

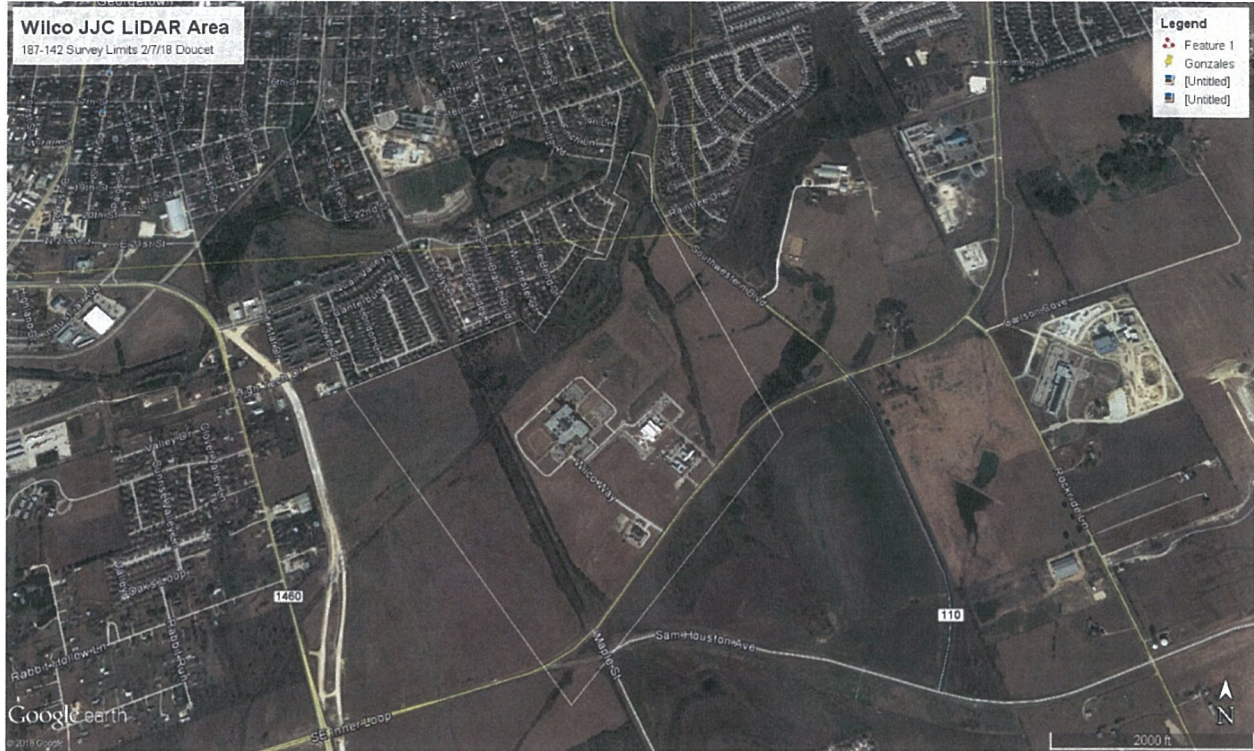

Attachment C - Work Schedule

Upon receiving authorization to proceed from the County, the team will complete Tasks 3 (Preliminary H&H Modeling), Task 4 (Preliminary Alternative Analyses), and Task 5 (Preliminary Engineering Report) within 6 weeks. Task 1 (Field Surveying) will be completed within two weeks from Notice to Proceed and access to all needed properties is granted. After receiving the field surveying results, the team anticipates completion of Task 1 and Tasks 6 through 9 and the delivery of a draft report within 3 months.

Attachment D - Fee Schedule

Description	Basis of Payment	Estimated Fee
I. PER Evaluation		
1. Field Surveying	Rate Schedule	\$ 8,000.00
2. Project Meetings	Rate Schedule	\$ 15,000.00
3. Preliminary H&H Modeling	Rate Schedule	\$ 23,000.00
4. Preliminary Alternative Analyses	Rate Schedule	\$ 23,000.00
5. Preliminary Engineering Memo	Rate Schedule	\$ 5,000.00
6. Refined H&H Modeling	Rate Schedule	\$ 15,000.00
7. Refined Alternative Analyses	Rate Schedule	\$ 15,000.00
8. Refined Engineering Report	Rate Schedule	\$ 7,500.00
9. Grant Opportunities	Rate Schedule	\$ 2,000.00
Reimbursables Expenses	(at cost-estimate)	\$ 750.00
	Total Cost:	\$114,250.00

Commissioners Court - Regular Session

31.

Meeting Date: 02/27/2018

North Campus Facility P324 - Change Order 39

Submitted By: Gina Wrehsnig, Infrastructure

Department: Infrastructure

Division: Building Maintenance

Agenda Category: Regular Agenda Items

Information

Agenda Item

Discuss, consider and take appropriate action on the Williamson County North Campus Project; Change Order #39 from Vaughn Construction for time extension to the contract of 15 days due to inclement weather.

Background

All bad weather days have been tracked throughout the project and agreed upon by the Owner and Contractor.

Fiscal Impact

From/To	Acct No.	Description	Amount
---------	----------	-------------	--------

Attachments

[NCF Change Order 39](#)

[NCF CO39 Funds](#)

Form Review

Inbox

County Judge Exec Asst.

Form Started By: Gina Wrehsnig

Final Approval Date: 02/22/2018

Reviewed By

Wendy Coco

Date

02/22/2018 08:28 AM

Started On: 02/22/2018 07:51 AM



3171 SE Inner Loop
Georgetown, TX
78626

T: (512) 663-7461
F: (512) 681-9752

February 13, 2018

Dwayne Gossett
Williamson County, Texas
3101 SE Inner Loop
Georgetown, TX 78620

Re: North Campus Facilities

Job No: 233901

Subj: Change Proposal No. 233901-0039

Dear Sir or Madam:

We respectfully submit our proposal for an increase to our contract in the amount of \$0 (zero) dollars to provide Weather Days for the above referenced project.

Recuperating Lost Days Due To Weather

Our price is valid for Ten (10) days

Please indicate your acceptance of this change proposal by signing and returning one copy of the attached Form B breakdown of our cost.

Very truly yours,
VAUGHN CONSTRUCTION

A handwritten signature in blue ink, appearing to read "DBoram".

Doug Boram

Attachments: Form B

CC: Brody Harris - BLGY
Mark Brown - BLGY

FORM B

PROJECT: North Campus Facilities

CHANGE PROPOSAL NO: 233901-0039

QUOTATION :

<u>Item</u>	<u>Labor</u>	<u>Materials</u>	<u>Subs</u>	<u>Total</u>
Weather Days	\$0.00	\$0.00	\$0.00	\$0.00
Totals	\$0.00	\$0.00	\$0.00	\$0.00
	Insurance, Tax, Benefits on Labor			\$0.00
	Overhead			\$0.00
	Fee on Subs			\$0.00
	Fee on JTV			\$0.00
	Bond			\$0.00
	Remodel Tax			\$0.00
	TOTAL			\$0.00

TIME EXTENSION TO CONTRACT: 15 Days

Submitted Date: 2/13/2018

Accepted

VAUGHN CONSTRUCTION

By: _____

By:  _____
Doug Boram

Date _____

Proposal Valid for 10 Days

Williamson County
 Williamson County North Campus Facilities
 Vaughn Project No. 2339-01



Funds Tracking Log

Change Proposal No.	Change Type & No.	Time Extension (Days)		GMP Breakdown						GMP #2339.01	Total Updated Contract Amount
		Pending	Approved	Cost of Work	CM Contingency	Owner Contingency	General Conditions	Buyout Savings	Construction Phase Fee		
N/A	GMP	-	-	\$18,195,395	\$406,771	\$406,771	\$1,896,522		\$625,467	\$21,530,926	\$21,530,926
1	OCO	0	0	\$3,659	\$0	(\$3,659)	\$0		\$0	\$0	\$21,530,926
2	OCO	10	10	\$114,186	\$0	(\$114,186)	\$0		\$0	\$0	\$21,530,926
3	OCO	0	0	\$1,727	\$0	(\$1,748)	\$21		\$0	\$0	\$21,530,926
4	OCO	0	0	\$19,494	\$0	(\$19,494)	\$0		\$0	\$0	\$21,530,926
5	OCO	0	0	\$19,676	(\$19,676)	\$0	\$0		\$0	\$0	\$21,530,926
6	OCO	0	0	\$14,465	(\$14,465)	\$0	\$0		\$0	\$0	\$21,530,926
7	OCO	0	0	\$2,237	\$0	(\$2,237)	\$0		\$0	\$0	\$21,530,926
8	OCO	0	0	\$3,450	\$0	(\$3,450)	\$0		\$0	\$0	\$21,530,926
9	OCO	0	0	\$832	\$0	(\$832)	\$0		\$0	\$0	\$21,530,926
10	OCO	0	0	\$285	\$0	(\$285)	\$0		\$0	\$0	\$21,530,926
11	OCO	0	0	\$22,415	\$0	(\$22,415)	\$0		\$0	\$0	\$21,530,926
12	OCO	0	0	\$11,221	\$0	(\$11,221)	\$0		\$0	\$0	\$21,530,926
13	OCO	0	0	(\$5,000)	\$0	\$5,000	\$0		\$0	\$0	\$21,530,926
14	OCO	0	0	\$0	\$0	\$0	\$0		\$0	\$0	\$21,530,926
15	OCO	0	0	\$79,584	\$0	(\$79,584)	\$0		\$0	\$0	\$21,530,926
16	OCO	0	0	\$9,930	\$0	(\$9,930)	\$0		\$0	\$0	\$21,530,926
17	OCO	0	0	\$2,450	(\$2,450)	\$0	\$0		\$0	\$0	\$21,530,926
18	OCO	0	0	\$1,747	(\$1,747)	\$0	\$0		\$0	\$0	\$21,530,926
19	OCO	0	0	(\$1,763)	\$0	\$0	\$1,763		\$0	\$0	\$21,530,926
20	OCO	0	0	\$5,784	\$0	(\$5,856)	\$72		\$0	\$0	\$21,530,926
21	OCO	0	0	\$10,364	(\$10,364)	\$0	\$0		\$0	\$0	\$21,530,926
22	OCO	0	0	\$6,410	(\$6,461)	\$0	\$51		\$0	\$0	\$21,530,926
23	OCO	0	0	\$15,825	(\$15,825)	\$0	\$0		\$0	\$0	\$21,530,926
24	OCO	0	0	\$33,487	(\$33,906)	\$0	\$419		\$0	\$0	\$21,530,926
25	OCO	0	0	\$8,854	(\$8,854)	\$0	\$0		\$0	\$0	\$21,530,926
26	OCO	0	-	(\$106)	\$0	\$106	\$0		\$0	\$0	\$21,530,926
27R	OCO	0	-	\$2,687	\$0	(\$2,687)	\$0		\$0	\$0	\$21,530,926
28	Void	0	0	\$0	\$0	\$0	\$0		\$0	\$0	\$21,530,926
29	OCO	0	-	\$3,647	(\$3,647)	\$0	\$0		\$0	\$0	\$21,530,926
30	OCO	0	0	(\$30,000)	\$0	\$30,000	\$0		\$0	\$0	\$21,530,926
31	OCO	0	0	\$4,434	\$0	(\$4,434)	\$0		\$0	\$0	\$21,530,926

32	OCO	0	0	\$6,816	\$0	(\$6,816)	\$0		\$0	\$0	\$21,530,926
33R	OCO	0	-	(\$28,265)	\$0	\$28,265	\$0		\$0	\$0	\$21,530,926
34	OCO	0	0	\$5,273	(\$5,273)	\$0	\$0		\$0	\$0	\$21,530,926
35	OCO	0	0	(\$168,250)	\$0	\$0	\$0		\$0	(\$168,250)	\$21,362,676
36	OCO	0	0	\$1,280	(\$1,280)	\$0	\$0		\$0	\$0	\$21,362,676
37	OCO	0	0	\$1,601	(\$1,601)	\$0	\$0		\$0	\$0	\$21,362,676
38R	OCO	0	-	\$4,646	(\$4,646)	\$0	\$0		\$0	\$0	\$21,362,676
39R	OCO	10	-	\$0	\$0	\$0	\$0		\$0	\$0	\$21,362,676
Current Amounts		20	10	\$18,380,477	\$276,576	\$181,308	\$1,898,848	\$0	\$625,467	\$21,362,676	\$21,362,676

VAUGHN CONSTRUCTION
Contract Time Statement / Weather Day Tracking

Proj. Name Williamson County North Campus Facility Proj.# 2339-01
 Owner Williamson County Location Georgetown, Texas Report Period: Jan 2017

Day of Week	Date Days	Extended Days	Inclement Weather	Amt. Rain Today	Work Day?	Major Work Delayed?
			(??) Rain Days by Contract This Month			
Sunday	1					
Monday	2					
Tuesday	3					
Wednesday	4					
Thursday	5					
Friday	6					
Saturday	7					
Sunday	8					
Monday	9					
Tuesday	10					
Wednesday	11					
Thursday	12					
Friday	13		Rain Out	1"	Yes	Yes
Saturday	14					
Sunday	15					
Monday	16		Drying Out Day for WPM		Yes	Yes
Tuesday	17		Drying Out Day then Additional Rain	1/4"	Yes	Yes
Wednesday	18		Rain Out Day for WPM	3/8"	Yes	Yes
Thursday	19		Drying Out Day / Dewatering	-	Yes	Yes
Friday	20					
Saturday	21					
Sunday	22					
Monday	23					
Tuesday	24					
Wednesday	25					
Thursday	26					
Friday	27					
Saturday	28					
Sunday	29					
Monday	30					
Tuesday	31					
		Extended Days This Month				

RECOMMENDED: _____

VAUGHN CONSTRUCTION
Contract Time Statement / Weather Day Tracking

Proj. Name Williamson County North Campus Facility Proj.# 2339-01
 Owner Williamson County Location Georgetown, Texas Report Period: Feb 2017

Day of Week	Date Days	Extended Days	Inclement Weather	Amt. Rain Today	Work Day?	Major Work Delayed?
(??) Rain Days by Contract This Month						
Wednesday	1					
Thursday	2					
Friday	3					
Saturday	4					
Sunday	5					
Monday	6					
Tuesday	7					
Wednesday	8					
Thursday	9					
Friday	10					
Saturday	11					
Sunday	12					
Monday	13					
Tuesday	14		Rain Out	1"	Yes	Yes
Wednesday	15		Rain Out Day for WPM, Keystone, SEC, LP		Yes	Yes
Thursday	16					
Friday	17					
Saturday	18					
Sunday	19					
Monday	20		Rain Out	1.5"	Yes	Yes
Tuesday	21					
Wednesday	22					
Thursday	23					
Friday	24					
Saturday	25					
Sunday	26					
Monday	27					
Tuesday	28					
		Extended Days This Month				

RECOMMENDED: _____

VAUGHN CONSTRUCTION
Contract Time Statement / Weather Day Tracking

Proj. Name Williamson County North Campus Facility Proj.# 2339-01
 Owner Williamson County Location Georgetown, Texas Report Period: March 2017

Day of Week	Date Days	Extended Days	Inclement Weather	Amt. Rain Today	Work Day?	Major Work Delayed?
(??) Rain Days by Contract This Month						
Wednesday	1					
Thursday	2					
Friday	3					
Saturday	4		Rain Out	3/4"	Y	Y
Sunday	5					
Monday	6		Dewater Day		Y	Y
Tuesday	7					
Wednesday	8					
Thursday	9					
Friday	10					
Saturday	11					
Sunday	12					
Monday	13		Rain Out / Dewater Day	3/4"	Y	Y
Tuesday	14					
Wednesday	15					
Thursday	16					
Friday	17					
Saturday	18					
Sunday	19					
Monday	20					
Tuesday	21					
Wednesday	22					
Thursday	23					
Friday	24					
Saturday	25					
Sunday	26					
Monday	27					
Tuesday	28					
Wednesday	29		Rain Out / Dewater Day	3/4"	Y	Y
Thursday	30					
Friday	31					
		Extended Days This Month				

RECOMMENDED: _____

VAUGHN CONSTRUCTION
Contract Time Statement / Weather Day Tracking

Proj. Name Williamson County North Campus Facility Proj.# 2339-01
 Owner Williamson County Location Georgetown, Texas Report Period: May 2017

Day of Week	Date Days	Extended Days	Inclement Weather	Amt. Rain Today	Work Day?	Major Work Delayed?
			(??) Rain Days by Contract This Month			
Monday	1					
Tuesday	2					
Wednesday	3					
Thursday	4					
Friday	5					
Saturday	6					
Sunday	7					
Monday	8					
Tuesday	9					
Wednesday	10					
Thursday	11					
Friday	12					
Saturday	13					
Sunday	14					
Monday	15					
Tuesday	16					
Wednesday	17					
Thursday	18					
Friday	19					
Saturday	20					
Sunday	21					
Monday	22		Rain out (1-1/4" over the weekend)	1-1/4"	Y	Y
Tuesday	23					
Wednesday	24					
Thursday	25					
Friday	26					
Saturday	27					
Sunday	28					
Monday	29					
Tuesday	30					
Wednesday	31					
		Extended Days This Month				

RECOMMENDED: _____

VAUGHN CONSTRUCTION
Contract Time Statement / Weather Day Tracking

Proj. Name Williamson County North Campus Facility Proj.# 2339-01
 Owner Williamson County Location Georgetown, Texas Report Period: May 2017

Day of Week	Date Days	Extended Days	Inclement Weather	Amt. Rain Today	Work Day?	Major Work Delayed?
			(0) Rain Days by Contract This Month			
Tuesday	1					
Wednesday	2					
Thursday	3					
Friday	4					
Saturday	5					
Sunday	6					
Monday	7	1	Rain Out	4.333	Y	Y
Tuesday	8	1	Dry Out	0	Y	Y
Wednesday	9					
Thursday	10					
Friday	11					
Saturday	12					
Sunday	13					
Monday	14					
Tuesday	15					
Wednesday	16					
Thursday	17					
Friday	18					
Saturday	19					
Sunday	20					
Monday	21					
Tuesday	22					
Wednesday	23					
Thursday	24					
Friday	25					
Saturday	26					
Sunday	27					
Monday	28					
Tuesday	29					
Wednesday	30					
Thursday	31					
		Extended Days This Month				

RECOMMENDED: _____

VAUGHN CONSTRUCTION
Contract Time Statement / Weather Day Tracking

Proj. Name Williamson County North Campus Facility Proj.# 2339-01
 Owner Williamson County Location Georgetown, Texas Report Period: Aug 2017

Day of Week	Date Days	Extended Days	Inclement Weather	Amt. Rain Today	Work Day?	Major Work Delayed?
(0) Rain Days by Contract This Month						
Tuesday	1					
Wednesday	2					
Thursday	3					
Friday	4					
Saturday	5					
Sunday	6					
Monday	7	1	Rain Out	4.333	Y	Y
Tuesday	8	1	Dry Out	0	Y	Y
Wednesday	9					
Thursday	10					
Friday	11					
Saturday	12					
Sunday	13					
Monday	14					
Tuesday	15					
Wednesday	16					
Thursday	17					
Friday	18					
Saturday	19					
Sunday	20					
Monday	21					
Tuesday	22					
Wednesday	23					
Thursday	24					
Friday	25					
Saturday	26					
Sunday	27					
Monday	28					
Tuesday	29					
Wednesday	30					
Thursday	31					
		Extended Days This Month				

RECOMMENDED: _____

Williamson County Facilities - Job Cost Tracking Log

Project: North Campus Project # P324

Change Order #: 39

Change Order No.	Court Agenda Date	Party of Initiation	Time Ext. (Days)	GMP Breakdown						GMP Total	Total Updated Contract Amount
				Cost of Work	CM Contingency	Owner Contingency	Buyout Savings (Current)	General Conditions	Construction Phase Fee		
Contract				\$ 18,027,145.00	\$ 406,771.00	\$ 406,772.00	\$ -	\$ 1,896,522.00	\$ 625,467.00	\$ 21,362,677.00	\$ 21,362,677.00
1	03/28/17		0	\$ 3,659.00	\$ -	\$ (3,659.00)	\$ -	\$ -	\$ -	\$ -	\$ 21,362,677.00
2	03/28/17		10	\$ 114,186.00	\$ -	\$ (114,186.00)	\$ -	\$ -	\$ -	\$ -	\$ 21,362,677.00
3	05/02/17		0	\$ 1,727.00	\$ -	\$ (1,727.00)	\$ -	\$ -	\$ -	\$ -	\$ 21,362,677.00
4	05/02/17		0	\$ 19,494.00	\$ -	\$ (19,494.00)	\$ -	\$ -	\$ -	\$ -	\$ 21,362,677.00
5	05/30/17		0	\$ 19,676.00	\$ (19,676.00)	\$ -	\$ -	\$ -	\$ -	\$ -	\$ 21,362,677.00
6	05/30/17		0	\$ 14,465.00	\$ (14,465.00)	\$ -	\$ -	\$ -	\$ -	\$ -	\$ 21,362,677.00
7	05/30/17		0	\$ 2,237.00	\$ -	\$ (2,237.00)	\$ -	\$ -	\$ -	\$ -	\$ 21,362,677.00
8	05/30/17		0	\$ 3,450.00	\$ -	\$ (3,450.00)	\$ -	\$ -	\$ -	\$ -	\$ 21,362,677.00
9	06/27/17		0	\$ 832.00	\$ -	\$ (832.00)	\$ -	\$ -	\$ -	\$ -	\$ 21,362,677.00
10	06/27/17		0	\$ 285.00	\$ -	\$ (285.00)	\$ -	\$ -	\$ -	\$ -	\$ 21,362,677.00
11	06/27/17		0	\$ 22,415.00	\$ -	\$ (22,415.00)	\$ -	\$ -	\$ -	\$ -	\$ 21,362,677.00
12	06/27/17		0	\$ 11,221.00	\$ -	\$ (11,221.00)	\$ -	\$ -	\$ -	\$ -	\$ 21,362,677.00
13	06/27/17		0	\$ (5,000.00)	\$ -	\$ 5,000.00	\$ -	\$ -	\$ -	\$ -	\$ 21,362,677.00
14	06/27/17		0	\$ -	\$ -	\$ -	\$ -	\$ -	\$ -	\$ -	\$ 21,362,677.00
15	06/27/17		0	\$ 79,584.00	\$ -	\$ (79,584.00)	\$ -	\$ -	\$ -	\$ -	\$ 21,362,677.00
16	06/27/17		0	\$ 9,930.00	\$ -	\$ (9,930.00)	\$ -	\$ -	\$ -	\$ -	\$ 21,362,677.00
17	09/12/17	A&E	0	\$ 2,450.00	\$ -	\$ -	\$ (2,450.00)	\$ -	\$ -	\$ -	\$ 21,362,677.00
18	09/12/17	A&E	0	\$ 1,747.00	\$ (1,747.00)	\$ -	\$ -	\$ -	\$ -	\$ -	\$ 21,362,677.00
19	09/12/17	Owner	0	\$ 577,128.00	\$ -	\$ -	\$ (577,128.00)	\$ -	\$ -	\$ -	\$ 21,362,677.00
20	12/05/17	A&E	0	\$ 5,784.00	\$ -	\$ (5,856.00)	\$ -	\$ 72.00	\$ -	\$ -	\$ 21,362,677.00
21	10/03/17	A&E	0	\$ 10,364.00	\$ (10,364.00)	\$ -	\$ -	\$ -	\$ -	\$ -	\$ 21,362,677.00
22	10/03/17	A&E	0	\$ 6,461.00	\$ (6,461.00)	\$ -	\$ -	\$ -	\$ -	\$ -	\$ 21,362,677.00
23	12/05/17	A&E	0	\$ 15,825.00	\$ (15,825.00)	\$ -	\$ -	\$ -	\$ -	\$ -	\$ 21,362,677.00
24	10/03/17	A&E	0	\$ 33,906.00	\$ (33,906.00)	\$ -	\$ -	\$ -	\$ -	\$ -	\$ 21,362,677.00
25	10/03/17	A&E	0	\$ 8,854.00	\$ (8,854.00)	\$ -	\$ -	\$ -	\$ -	\$ -	\$ 21,362,677.00
26	02/06/18	A&E	0	\$ (106.00)	\$ -	\$ 106.00	\$ -	\$ -	\$ -	\$ -	\$ 21,362,677.00
27		A&E	0	\$ 2,687.00	\$ -	\$ (2,687.00)	\$ -	\$ -	\$ -	\$ -	\$ 21,362,677.00
28	PENDING REVIEW										\$ 21,362,677.00
29	02/06/18	A&E	0	\$ 3,647.00	\$ (3,647.00)	\$ -	\$ -	\$ -	\$ -	\$ -	\$ 21,362,677.00
30	10/24/17	Contractor		\$ (30,000.00)	\$ -	\$ 30,000.00	\$ -	\$ -	\$ -	\$ -	\$ 21,362,677.00
31	10/24/17	A&E		\$ 4,434.00	\$ -	\$ (4,434.00)	\$ -	\$ -	\$ -	\$ -	\$ 21,362,677.00
32	11/14/17	A&E		\$ 6,816.00		\$ (6,816.00)	\$ -	\$ -	\$ -	\$ -	\$ 21,362,677.00
33	PENDING REVIEW										\$ 21,362,677.00
34	11/14/17	Contractor		\$ 5,273.00	\$ (5,273.00)	\$ -	\$ -	\$ -	\$ -	\$ -	\$ 21,362,677.00
35	PENDING REVIEW										\$ 21,362,677.00
36	12/05/17	A&E	0	\$ 1,280.00	\$ (1,280.00)	\$ -	\$ -	\$ -	\$ -	\$ -	\$ 21,362,677.00
37	12/05/17	A&E	0	\$ 1,601.00	\$ (1,601.00)	\$ -	\$ -	\$ -	\$ -	\$ -	\$ 21,362,677.00
38	PENDING REVIEW										\$ 21,362,677.00
39		Contractor	15	\$ -	\$ -	\$ -	\$ -	\$ -	\$ -	\$ -	\$ 21,362,677.00
40	PENDING REVIEW										\$ 21,362,677.00
41	02/06/18	Owner	0	\$ (50,311.00)		\$ 50,311.00	\$ -	\$ -	\$ -	\$ -	\$ 21,362,677.00
							\$ -	\$ -	\$ -	\$ -	\$ 21,362,677.00
			25	\$ 18,933,146.00	\$ 283,672.00	\$ 203,376.00	\$ (579,578.00)	\$ 1,896,594.00	\$ 625,467.00	\$ 21,362,677.00	\$ 21,362,677.00

Commissioners Court - Regular Session

32.

Meeting Date: 02/27/2018

North Campus Facility P324 - Change Order 42

Submitted By: Gina Wrehsnig, Infrastructure

Department: Infrastructure

Division: Building Maintenance

Agenda Category: Regular Agenda Items

Information

Agenda Item

Discuss, consider and take appropriate action on the Williamson County North Campus Project; Change Order #42 from Vaughn Construction in the amount of (\$44,494.00) to receive credit for asphalt paving that was removed from the original scope of the project. This change order is being credited back to the Owners Contingency.

Background

The scope of asphalt paving removed from the project was Owner directed and it was mutually agreed upon by the Owner and Contractor to remove it from the project.

Fiscal Impact

From/To	Acct No.	Description	Amount
---------	----------	-------------	--------

Attachments

[NCF Change Order 42](#)

[NCF CO42 Funds](#)

Form Review

Inbox

County Judge Exec Asst.

Form Started By: Gina Wrehsnig

Final Approval Date: 02/22/2018

Reviewed By

Wendy Coco

Date

02/22/2018 08:28 AM

Started On: 02/22/2018 07:54 AM



3171 SE Inner Loop
Georgetown, TX
78626

T: (512) 663-7461
F: (512) 681-9752

February 13, 2018

Dwayne Gossett
Williamson County, Texas
3101 SE Inner Loop
Georgetown, TX 78620

Re: North Campus Facilities
Job No: 233901

Subj: Change Proposal No. 233901-0042

Dear Sir or Madam:

We respectfully submit our proposal for an increase to our contract in the amount of \$0 (zero) dollars to provide Credit for Removal of Asphalt from Scope per ASI-024 dated 9/7/2017 for the above referenced project.

Our price is valid for Ten (10) days

Please indicate your acceptance of this change proposal by signing and returning one copy of the attached Form B breakdown of our cost.

Very truly yours,
VAUGHN CONSTRUCTION

A handwritten signature in black ink, appearing to read "DBoram", written over a faint circular stamp or watermark.

Doug Boram

Attachments: Form B, Subcontractor Pricing Back-up

CC: Brody Harris - BLGY
Mark Brown - BLGY

FORM B

PROJECT: North Campus Facilities

CHANGE PROPOSAL NO: 233901-0042

QUOTATION :

<u>Item</u>	<u>Labor</u>	<u>Materials</u>	<u>Subs</u>	<u>Total</u>
Credit for Removal of Asphalt from Scope per ASI-024	\$0.00	\$0.00	\$(22,247.00)	\$(22,247.00)
Additional Subgrade Prep due to Asphalt Work Not in Vaughns Contract	\$0.00	\$0.00	\$(22,247.00)	\$(22,247.00)
To Be Credited to Owners Contingency	\$0.00	\$44,494.00	\$0.00	\$44,494.00

Totals	\$0.00	\$44,494.00	\$(44,494.00)	\$0.00
	Insurance, Tax, Benefits on Labor			\$0.00
	Overhead			\$0.00
	Fee on Subs			\$0.00
	Fee on JTV			\$0.00
	Bond			\$0.00
	Remodel Tax			\$0.00
	TOTAL			\$0.00

TIME EXTENSION TO CONTRACT: 0 Days

Submitted Date: 2/13/2018

Accepted

VAUGHN CONSTRUCTION

By: _____

By: 
Doug Boram

Date _____

Proposal Valid for 10 Days

Williamson County
 Williamson County North Campus Facilities
 Vaughn Project No. 2339-01



Funds Tracking Log

Change Proposal No.	Change Type & No.	Time Extension (Days)		GMP Breakdown						GMP #2339.01	Total Updated Contract Amount
		Pending	Approved	Cost of Work	CM Contingency	Owner Contingency	General Conditions	Buyout Savings	Construction Phase Fee		
N/A	GMP	-	-	\$18,195,395	\$406,771	\$406,772	\$1,896,522		\$625,467	\$21,530,927	\$21,530,927
1	OCO	0	0	\$3,659	\$0	(\$3,659)	\$0		\$0	\$0	\$21,530,927
2	OCO	10	10	\$114,186	\$0	(\$114,186)	\$0		\$0	\$0	\$21,530,927
3	OCO	0	0	\$1,727	\$0	(\$1,748)	\$21		\$0	\$21	\$21,530,948
4	OCO	0	0	\$19,494	\$0	(\$19,494)	\$0		\$0	\$0	\$21,530,948
5	OCO	0	0	\$19,676	(\$19,676)	\$0	\$0		\$0	\$0	\$21,530,948
6	OCO	0	0	\$14,465	(\$14,465)	\$0	\$0		\$0	\$0	\$21,530,948
7	OCO	0	0	\$2,237	\$0	(\$2,237)	\$0		\$0	\$0	\$21,530,948
8	OCO	0	0	\$3,450	\$0	(\$3,450)	\$0		\$0	\$0	\$21,530,948
9	OCO	0	0	\$832	\$0	(\$832)	\$0		\$0	\$0	\$21,530,948
10	OCO	0	0	\$285	\$0	(\$285)	\$0		\$0	\$0	\$21,530,948
11	OCO	0	0	\$22,415	\$0	(\$22,415)	\$0		\$0	\$0	\$21,530,948
12	OCO	0	0	\$11,221	\$0	(\$11,221)	\$0		\$0	\$0	\$21,530,948
13	OCO	0	0	(\$5,000)	\$0	\$5,000	\$0		\$0	\$0	\$21,530,948
14	OCO	0	0	\$0	\$0	\$0	\$0		\$0	\$0	\$21,530,948
15	OCO	0	0	\$79,584	\$0	(\$79,584)	\$0		\$0	\$0	\$21,530,948
16	OCO	0	0	\$9,930	\$0	(\$9,930)	\$0		\$0	\$0	\$21,530,948
17	OCO	0	0	\$2,450	(\$2,450)	\$0	\$0		\$0	\$0	\$21,530,948
18	OCO	0	0	\$1,747	(\$1,747)	\$0	\$0		\$0	\$0	\$21,530,948
19	OCO	0	0	(\$1,763)	\$0	\$0	\$1,763		\$0	\$0	\$21,530,948
20	OCO	0	0	\$5,784	\$0	(\$5,856)	\$72		\$0	\$72	\$21,531,020
21	OCO	0	0	\$10,364	(\$10,364)	\$0	\$0		\$0	\$0	\$21,531,020
22	OCO	0	0	\$6,410	(\$6,461)	\$0	\$51		\$0	\$0	\$21,531,020
23	OCO	0	0	\$15,825	(\$15,825)	\$0	\$0		\$0	\$0	\$21,531,020
24	OCO	0	0	\$33,487	(\$33,906)	\$0	\$419		\$0	\$0	\$21,531,020
25	OCO	0	0	\$8,854	(\$8,854)	\$0	\$0		\$0	\$0	\$21,531,020
26	OCO	0	-	(\$106)	\$0	\$106	\$0		\$0	\$0	\$21,531,020
27R	OCO	0	-	\$2,687	\$0	(\$2,687)	\$0		\$0	\$0	\$21,531,020
28	Void	0	0	\$0	\$0	\$0	\$0		\$0	\$0	\$21,531,020
29	OCO	0	-	\$3,647	(\$3,647)	\$0	\$0		\$0	\$0	\$21,531,020
30	OCO	0	0	(\$30,000)	\$0	\$30,000	\$0		\$0	\$0	\$21,531,020
31	OCO	0	0	\$4,434	\$0	(\$4,434)	\$0		\$0	\$0	\$21,531,020

32	OCO	0	0	\$6,816	\$0	(\$6,816)	\$0		\$0	\$0	\$21,531,020
33R	OCO	0	-	(\$28,265)	\$0	\$28,265	\$0		\$0	\$0	\$21,530,927
34	OCO	0	0	\$5,273	(\$5,273)	\$0	\$0		\$0	\$0	\$21,531,020
35	OCO	0	0	(\$168,250)	\$0	\$0	\$0		\$0	(\$168,250)	\$21,362,770
36	OCO	0	0	\$1,280	(\$1,280)	\$0	\$0		\$0	\$0	\$21,531,020
37	OCO	0	0	\$1,601	(\$1,601)	\$0	\$0		\$0	\$0	\$21,531,020
38R	OCO	0	-	\$4,646	(\$4,646)	\$0	\$0		\$0	\$0	\$21,531,020
39R	OCO	10	-	\$0	\$0	\$0	\$0		\$0	\$0	\$21,531,020
40R	OCO	0	-	(\$6,292)	\$0	\$6,292	\$0		\$0	\$0	\$21,531,020
41	OCO	0	-	(\$50,311)	\$0	\$50,311	\$0		\$0	\$0	\$21,531,020
42R	OCO	0	-	(\$44,494)	\$0	\$44,494	\$0		\$0	\$0	\$21,531,020
Current Amounts		20	10	\$18,279,380	\$276,576	\$282,406	\$1,898,848	\$0	\$625,467	\$21,362,770	\$21,362,770

Williamson County Facilities - Job Cost Tracking Log

Project: North Campus Project # P324

Change Order #: 42

Change Order No.	Court Agenda Date	Party of Initiation	Time Ext. (Days)	GMP Breakdown						GMP Total	Total Updated Contract Amount
				Cost of Work	CM Contingency	Owner Contingency	Buyout Savings (Current)	General Conditions	Construction Phase Fee		
Contract				\$ 18,027,145.00	\$ 406,771.00	\$ 406,772.00	\$ -	\$ 1,896,522.00	\$ 625,467.00	\$ 21,362,677.00	\$ 21,362,677.00
1	03/28/17		0	\$ 3,659.00	\$ -	\$ (3,659.00)	\$ -	\$ -	\$ -	\$ -	\$ 21,362,677.00
2	03/28/17		10	\$ 114,186.00	\$ -	\$ (114,186.00)	\$ -	\$ -	\$ -	\$ -	\$ 21,362,677.00
3	05/02/17		0	\$ 1,727.00	\$ -	\$ (1,727.00)	\$ -	\$ -	\$ -	\$ -	\$ 21,362,677.00
4	05/02/17		0	\$ 19,494.00	\$ -	\$ (19,494.00)	\$ -	\$ -	\$ -	\$ -	\$ 21,362,677.00
5	05/30/17		0	\$ 19,676.00	\$ (19,676.00)	\$ -	\$ -	\$ -	\$ -	\$ -	\$ 21,362,677.00
6	05/30/17		0	\$ 14,465.00	\$ (14,465.00)	\$ -	\$ -	\$ -	\$ -	\$ -	\$ 21,362,677.00
7	05/30/17		0	\$ 2,237.00	\$ -	\$ (2,237.00)	\$ -	\$ -	\$ -	\$ -	\$ 21,362,677.00
8	05/30/17		0	\$ 3,450.00	\$ -	\$ (3,450.00)	\$ -	\$ -	\$ -	\$ -	\$ 21,362,677.00
9	06/27/17		0	\$ 832.00	\$ -	\$ (832.00)	\$ -	\$ -	\$ -	\$ -	\$ 21,362,677.00
10	06/27/17		0	\$ 285.00	\$ -	\$ (285.00)	\$ -	\$ -	\$ -	\$ -	\$ 21,362,677.00
11	06/27/17		0	\$ 22,415.00	\$ -	\$ (22,415.00)	\$ -	\$ -	\$ -	\$ -	\$ 21,362,677.00
12	06/27/17		0	\$ 11,221.00	\$ -	\$ (11,221.00)	\$ -	\$ -	\$ -	\$ -	\$ 21,362,677.00
13	06/27/17		0	\$ (5,000.00)	\$ -	\$ 5,000.00	\$ -	\$ -	\$ -	\$ -	\$ 21,362,677.00
14	06/27/17		0	\$ -	\$ -	\$ -	\$ -	\$ -	\$ -	\$ -	\$ 21,362,677.00
15	06/27/17		0	\$ 79,584.00	\$ -	\$ (79,584.00)	\$ -	\$ -	\$ -	\$ -	\$ 21,362,677.00
16	06/27/17		0	\$ 9,930.00	\$ -	\$ (9,930.00)	\$ -	\$ -	\$ -	\$ -	\$ 21,362,677.00
17	09/12/17	A&E	0	\$ 2,450.00	\$ -	\$ -	\$ (2,450.00)	\$ -	\$ -	\$ -	\$ 21,362,677.00
18	09/12/17	A&E	0	\$ 1,747.00	\$ (1,747.00)	\$ -	\$ -	\$ -	\$ -	\$ -	\$ 21,362,677.00
19	09/12/17	Owner	0	\$ 577,128.00	\$ -	\$ -	\$ (577,128.00)	\$ -	\$ -	\$ -	\$ 21,362,677.00
20	12/05/17	A&E	0	\$ 5,784.00	\$ -	\$ (5,856.00)	\$ -	\$ 72.00	\$ -	\$ -	\$ 21,362,677.00
21	10/03/17	A&E	0	\$ 10,364.00	\$ (10,364.00)	\$ -	\$ -	\$ -	\$ -	\$ -	\$ 21,362,677.00
22	10/03/17	A&E	0	\$ 6,461.00	\$ (6,461.00)	\$ -	\$ -	\$ -	\$ -	\$ -	\$ 21,362,677.00
23	12/05/17	A&E	0	\$ 15,825.00	\$ (15,825.00)	\$ -	\$ -	\$ -	\$ -	\$ -	\$ 21,362,677.00
24	10/03/17	A&E	0	\$ 33,906.00	\$ (33,906.00)	\$ -	\$ -	\$ -	\$ -	\$ -	\$ 21,362,677.00
25	10/03/17	A&E	0	\$ 8,854.00	\$ (8,854.00)	\$ -	\$ -	\$ -	\$ -	\$ -	\$ 21,362,677.00
26	02/06/18	A&E	0	\$ (106.00)	\$ -	\$ 106.00	\$ -	\$ -	\$ -	\$ -	\$ 21,362,677.00
27		A&E	0	\$ 2,687.00	\$ -	\$ (2,687.00)	\$ -	\$ -	\$ -	\$ -	\$ 21,362,677.00
28	PENDING REVIEW										\$ 21,362,677.00
29	02/06/18	A&E	0	\$ 3,647.00	\$ (3,647.00)	\$ -	\$ -	\$ -	\$ -	\$ -	\$ 21,362,677.00
30	10/24/17	Contractor		\$ (30,000.00)	\$ -	\$ 30,000.00	\$ -	\$ -	\$ -	\$ -	\$ 21,362,677.00
31	10/24/17	A&E		\$ 4,434.00	\$ -	\$ (4,434.00)	\$ -	\$ -	\$ -	\$ -	\$ 21,362,677.00
32	11/14/17	A&E		\$ 6,816.00	\$ -	\$ (6,816.00)	\$ -	\$ -	\$ -	\$ -	\$ 21,362,677.00
33	PENDING REVIEW										\$ 21,362,677.00
34	11/14/17	Contractor		\$ 5,273.00	\$ (5,273.00)	\$ -	\$ -	\$ -	\$ -	\$ -	\$ 21,362,677.00
35	PENDING REVIEW										\$ 21,362,677.00
36	12/05/17	A&E	0	\$ 1,280.00	\$ (1,280.00)	\$ -	\$ -	\$ -	\$ -	\$ -	\$ 21,362,677.00
37	12/05/17	A&E	0	\$ 1,601.00	\$ (1,601.00)	\$ -	\$ -	\$ -	\$ -	\$ -	\$ 21,362,677.00
38	PENDING REVIEW										\$ 21,362,677.00
39		Contractor	15	\$ -	\$ -	\$ -	\$ -	\$ -	\$ -	\$ -	\$ 21,362,677.00
40		Contractor	0	\$ (6,292.00)	\$ -	\$ 6,292.00	\$ -	\$ -	\$ -	\$ -	\$ 21,362,677.00
41	02/06/18	Owner	0	\$ (50,311.00)	\$ -	\$ 50,311.00	\$ -	\$ -	\$ -	\$ -	\$ 21,362,677.00
42		Contractor	0	\$ (44,494.00)	\$ -	\$ 44,494.00	\$ -	\$ -	\$ -	\$ -	\$ 21,362,677.00
				\$ -	\$ -	\$ -	\$ -	\$ -	\$ -	\$ -	\$ 21,362,677.00
			25	\$ 18,882,360.00	\$ 283,672.00	\$ 254,162.00	\$ (579,578.00)	\$ 1,896,594.00	\$ 625,467.00	\$ 21,362,677.00	\$ 21,362,677.00

Commissioners Court - Regular Session

33.

Meeting Date: 02/27/2018

Jail Remodel Project P411 - Contractor Amendment #1

Submitted By: Gina Wrehsnig, Infrastructure

Department: Infrastructure

Division: Building Maintenance

Agenda Category: Regular Agenda Items

Information

Agenda Item

Discuss, consider and take appropriate action on a First Amendment to an Agreement Between Owner and Contractor, by and between Williamson County and STR Constructors, LTD. relating to the Williamson County Jail Kitchen and Plumbing Remodel Project.

Background

This amendment is to increase the project Owners Contingency in order to fund change orders and potential change orders made necessary by unforeseen existing conditions in the infrastructure of the Jail Building. This increase will also help prevent further delays in the project.

Fiscal Impact

From/To	Acct No.	Description	Amount
---------	----------	-------------	--------

Attachments

STR Amendment #1

Form Review

Inbox

County Judge Exec Asst.

Form Started By: Gina Wrehsnig

Final Approval Date: 02/22/2018

Reviewed By

Wendy Coco

Date

02/22/2018 08:28 AM

Started On: 02/22/2018 08:02 AM

FIRST AMENDMENT TO
AGREEMENT BETWEEN OWNER AND CONTRACTOR

THIS FIRST AMENDMENT TO THAT CERTAIN AGREEMENT BETWEEN OWNER AND CONTRACTOR, hereinafter "First Amendment", is entered into effective as of the date of the last party's execution hereof, between Williamson County, Texas, a body corporate and politic under the laws of the State of Texas, hereinafter "County", and STR Constructors, LTD, hereinafter "Contractor".

RECITALS

WHEREAS, County and Contractor executed that certain agreement entitled Agreement Between Owner and Contractor, hereinafter the "Agreement", which became effective as of August 21, 2017 for the construction of the Williamson County Jail Kitchen and Plumbing Remodel (the "Project");

WHEREAS, it has become necessary to amend the Agreement in order to increase the Owner's Contingency from \$250,000.00 to \$450,000.00 due to various unforeseen conditions;

NOW, THEREFORE, premises considered, County and Contractor agree that the Agreement is amended as follows:

AGREEMENTS

1. **Section 5.3** of the Agreement shall be amended as follows:

5.3 Owner's Construction Contingency. The following lump sum amount shall serve as the Owner's Construction Contingency from which changes in the Work are to be paid in accordance with the General Conditions:

\$450,000.00

The Owner's Construction Contingency is controlled solely by the Owner. Expenditures from the Owner's Construction Contingency must be made by Change Order issued by the Architect and approved by the Owner in accordance with the General Conditions. Contractor shall not be entitled to any compensation from the any unused amounts of the Owner's Construction Contingency.

2. Each party represents and warrants that it has due power and lawful authority to execute and deliver this First Amendment and to perform its obligations under the Agreement; and, furthermore, the Agreement and this First Amendment are the valid, binding and enforceable obligations of such party.
3. All other terms of the Agreement and any prior amendments thereto which have not been specifically amended herein shall remain the same and shall continue in full force and effect.

IN WITNESS WHEREOF, the parties hereto have caused this First Amendment to be signed by their duly authorized representatives on behalf of such party, to be effective as of the date of the last party's execution hereof.

WILLIAMSON COUNTY, TEXAS:

STR CONSTRUCTORS, LTD., acting by and through its General Partner, R K Company, LLC:

By: _____
Dan A. Gattis, County Judge

_____, 20____
Date

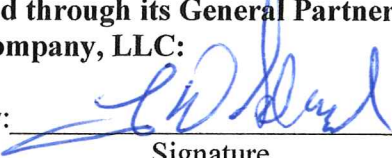
By:  _____
Signature

TOM STANFIELD

Printed Name

PROJECT MANAGER

Title

FEB 21, 2018

Date

Commissioners Court - Regular Session

34.

Meeting Date: 02/27/2018

Jail Remodel Project P411 - Change Order 5

Submitted By: Gina Wrehsnig, Infrastructure

Department: Infrastructure

Division: Building Maintenance

Agenda Category: Regular Agenda Items

Information

Agenda Item

Discuss, consider and take appropriate action on the Jail Kitchen and Plumbing Remodel Project; P411, Change Order # 5 from STR Constructors, LTD. in the amount of \$83,476.43 for additional electrical work associated with ASI # 3, and additional plumbing work in the main North Jail plumbing chases. This change order is being funded out of the Owners Contingency.

Background

This change order is to fund items of work that are necessary for the installation of the new appliance package, which were not included in the original scope of work, and to add isolation valves in all plumbing chases to help facilitate future maintenance and repair.

Fiscal Impact

From/To	Acct No.	Description	Amount
---------	----------	-------------	--------

Attachments

Jail Change Order 5

Jail CO5 Funds

Form Review

Inbox

County Judge Exec Asst.

Form Started By: Gina Wrehsnig

Final Approval Date: 02/22/2018

Reviewed By

Wendy Coco

Date

02/22/2018 11:32 AM

Started On: 02/22/2018 11:28 AM



WILLIAMSON COUNTY, TEXAS
 FACILITIES DEPARTMENT
 3101 SE Inner Loop
 Georgetown, TX 78626
 512-943-1609

CHANGE ORDER

For Project: WILLIAMSON COUNTY JAIL KITCHEN & PLUMBING REMODEL
 Date of Issuance: 2/20/2018
 Contractor: STR Constructors, LTD.
 Project Engineer: Talex, Inc.

Change Order No: 5
 PID: _____

Explanation:

This change order is due to the following:

PCO #09R1 - Add for 2nd Floor Isolation Valves on Riser Pipes & 4th Floor Hotwater Loop Connections

PCO #14B - Add for Elec Changes per ASI 03 (Finalized Kitchen Equipment Layout)

Description of Work:	Cost	Additional Time	
		KITCHEN AREA	OVERALL PROJECT
See attached PCO #09R1	\$ 26,631.16	0 Days	15 Days
See attached PCO #14B	\$ 56,845.26	19 Days	19 Days
		0 Days	0 Days
		0 Days	0 Days
		0 Days	0 Days
		0 Days	0 Days
Weather Days -			0 Days
Sub-Total CO #3	\$ 83,476.43	19 Days	34 Days

Please Refer to Attached Backup Documents:

Cost and Time Change Summary

	Cost
Original Contract:	\$ 1,781,645.00
Previous Change Order(s):	\$ 248,138.25
Contract Prior to this CO:	\$ 2,029,783.25
Net Increase from this CO:	\$ 83,476.43
Revised Contract Total:	\$ 2,113,259.68

Additional Time	
KITCHEN AREA	OVERALL PROJECT
120 Days	180 Days
10 Days	20 Days
130 Days	200 Days
19 Days	34 Days
149 Days	234 Days

RECOMMENDED BY:

Gilbert Bolding
 Contractor Signature*
Oscar Villarreal
 Engineer Signature

Gilbert Bolding, Sr PM for
T. R. Kennedy, President
 Contractor Name
Oscar Villarreal, P.E.
 Engineer Name

2-20-18
 Signature Date
2/20/18
 Signature Date

ACCEPTED BY:

 Owner Signature

 Owners' Rep Name

 Signature Date

*By Signing this change order the Contractor accepts the changes herein and agrees to perform the change(s) for the price and time indicated. The prices include all costs to perform the work.

No work shall be done until this change order is executed. No payment to the Contractor (or Consultant) shall be made for work included in this Change Order until Contractor's pay estimate is updated.

In case of conflict between construction documents and this change order, this change order shall govern.

Upon execution of this Change Order by all parties, the Identified time and cost changes herein are made part of the contract documents.

STR CONSTRUCTORS, LTD.
CHANGE PROPOSAL

PROPOSAL ISSUED TO:	STR's PCO NO.: 09R1			
	Wilco Jail Kitchen & Plumbing Remodel 508 South Rock Street Georgetown, TX			
ATTENTION:	Dale Bulter Asst Director, Projects			
DESCRIPTION:	Add for Isolation Valves on the 2nd FI Vertical Risers & Complete 4th FI Hotwater Loop, as requested by Owner			
Description	Subcontracts	Material	Labor	Total
STR Constructor's Direct Costs				
(see attached STR GC Breakdown)		\$ 2,804.00	\$ 4,320.00	\$ 7,124.00
				\$ -
				\$ -
				\$ -
				\$ -
Subcontract Cost				\$ -
Specialized Plumbing Technologies				\$ -
(Add Iso Valves)	\$ 9,893.00			\$ 9,893.00
(Add 4th FI Loop Connections)	\$4,606.00			\$ 4,606.00
				\$ -
				\$ -
				\$ -
				\$ -
				\$ -
				\$ -
				\$ -
DIRECT COST	\$ 14,499.00	\$ 2,804.00	\$ 4,320.00	\$ 21,623.00
PAYROLL TAX & INSURANCE (STR's Labor)	32.58%			\$ 1,407.46
STR FEE ON OWN WORK	15.00%			\$ 1,279.72
STR FEE ON SUBCONTRACTORS	10.00%			\$ 1,449.90
BOND	2.50%			\$ 644.01
INSURANCE	0.86%			\$ 227.08
TOTAL COST				\$ 26,631.16
QUALIFICATIONS & CLARIFICATIONS:				
<p><i>Based on the sensitive time of this work being coordinated with the Boiler shut-down work (outside our scope) STR hereby requests an additional 15 calendar days in the Non-Kitchen Time Frame, as the epoxy work crews will preform this work and impact their epoxy pipe lining sequence NOTE: This proposal is based on installing these additional Isolation Valves concurrent with the Boiler Water Shut-down, so thereby does NOT include any Pipe Freezing</i></p>				
<p>This change proposal becomes null & void after ten calendar days (10) and extends the contract completion date by 10 working days at \$ 1,058.40 dollars of cost for general conditions expenses per each calendar day. Work stoppage due to late acceptance of this change proposal voids this quotation and will increase the cost by the General Contractor's general conditions expenses which exceed (\$ 1,481.76) per work day. One Work day = 1.4 Calendar days.</p>				
STR CONSTRUCTORS, LTD.			Approved by:	
<i>TD Starfield</i>				
Project Manager	DATE:	<i>2/7/2018</i>	Date:	

PAGE 1 - SITE GENERAL CONDITIONS

STR's PCO NO. : 09R1 JOB:
 EXTENDED DURATION 2 WEEKS

ITEM	NO.	WK.	RATE	MATERIALS	LABOR	TOTAL
PROJECT MANAGER		2	860		1720	1720
Superintendent		2	1300		2600	2600
Subsistance		2	250	500		500
Travel Expense		2	50	100		100
Field Office		2	170	340		340
Toilets		2	60	120		120
Fences		2	50	100		100
Elec Service		2	45	90		90
Ice & Cups		2	24	48		48
Telephone		2	30	60		60
Small Tools		2	50	100		100
Dumpster Pull		1	800	800		800
Pick Up Truck		2	128	256		256
Gas & Oil		2	70	140		140
O.S.H.A. / 1ST AID / Job Safety		2	75	150		150
						0
						0
TOTAL				2804	4320	7124
WEEKLY COST				1402	2160	3562
MONTHLY COST				6028.6	9288	15317



CHANGE ORDER

PROJECT:	WILCO Prison 508 South Rock Street Georgetown, TX 78626	CHANGE ORDER NUMBER:	3
		BID #	17-2648
		DATE:	2/7/2018
		CONTRACT DATE:	10/27/2017
CONTRACTOR:	Specialized Plumbing Technologies 226 Field End Street Sarasota, florida 34240	OWNER:	STR Constructors, LTD 15500 Hwy 29 West Liberty Hill, TX 78642

Change Order includes the following:

1	To provide and install (2) 2" Isolation Valves, (6) 1.5" Isolation Valves, and (8) 2.5" Isolation Valves, for a total of (16) Isolation Valves.	\$9,893.00
	Material	4,504.00
	Labor	2,640.00
	Per Diem & Travel	1,100.00
	Overhead & Profit	1,649.00
2	Per request by Tom Stanfeld, building of loops at top of risers between 3rd and 4th floor.	\$4,606.00
	Material	1,596.00
	Labor	1,600.00
	Per Diem & Travel	640.00
	Overhead & Profit	770.00
	Total	\$14,499.00

Not valid until signed by Owner and Contractor.

The original Contract Sum
 Net change by Change Order #1
 The Contract Sum prior to this Change Order was
 The Contract Sum will be increased by this Change Order in the amount of
 The Contract Sum including this Change Order

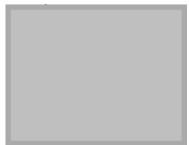

The Contract Time will be increased by 30 days.

Note: They are requesting 30 days, but we are holding them to 15 days additional & only charge for 10 days Gend Cond

Specialized Plumbing Technologies	STR Constructors, LTD
CONTRACTOR	OWNER
226 Field End Street	1550 Hwy 29 West
ADDRESS	ADDRESS
Sarasota, FL 34240	Liberty Hill, TX 78642
BY Bill Konkol	BY
DATE: 2/0719/18	DATE

PAGE 1 - SITE GENERAL CONDITIONS

STR's PCO NO. : 14B JOB:
 EXTENDED DURATION 3 WEEKS

ITEM	NO.	WK.	RATE	MATERIALS	LABOR	TOTAL
PROJECT MANAGER		3	860		2580	2580
Superintendent		3	1300		3900	3900
Subsistance		3	250	750		750
Travel Expense		3	50	150		150
Field Office		3	170	510		510
Toilets		3	60	180		180
Fences		3	50	150		150
Elec Service		3	55	165		165
Ice & Cups		3	24	72		72
Telephone		3	20	60		60
Small Tools		3	50	150		150
Dumpster Pull		1.5	800	1200		1200
Pick Up Truck		3	93	279		279
Gas & Oil		3	70	210		210
Progress Photos		3	35	105		105
O.S.H.A. / 1ST AID / Job Safety		3	75	225		225
						0
						0
TOTAL				4206	6480	10686
WEEKLY COST				1402	2160	3562
MONTHLY COST				6028.6	9288	15317

Doyle Electric, LLC

1108 S Lakeside Dr
Burnet, Texas 78611
Phone: 512-743-5534

Request for Change Order

2/15/2018

TO:

STR Constructors
Tom Stanfield
Liberty Hill, Texas 78642

JOB:

Project: Williamson County Jail Kitchen Renovation
508 S. Rock St. Georgetown, TX 78628
Change Order Number: ASI 3

CHANGE ORDER INFORMATION: ASI 3

WORK DESCRIPTION: Work includes demolition of existing conduit and wire where needed, re-use of existing conduit and wire where applicable, and installation of new conduit and wire as required. Specific inclusions are:

- Replace all existing receptacles in kitchen with new GFCI receptacles
- Equipment Hook-up where required
- Seal-tite whips provided where no receptacle is shown
- Extension of existing control wires for Bakery Oven and Dishwasher for Exhaust Fans
 1. Includes 2 hours for terminations and assistance for proper operation (each)
 2. Includes 20' of new 1/2" conduit and wire per equipment for proper operation (each)
 3. Includes new seal-tite whips for termination to equipment (all control terminations/relays by others)
- Blank covers for existing boxes/devices not used
- Reuse of existing breakers where applicable

The total amount of this Change Order is: **\$31,816.00**

Added Work Days (M-F): 24 Working Days

Note: STR reduced the requested additional time to 19 calendar days from the 32 calendar days Elec sub requires, but use of current over-lap

Exclusions:

- Overtime
- Tax
- Existing conditions of remaining electrical items
- Concrete cut/patch
- CMU patch
- Roof Flashing/Sealing

- **Roof penetrations**
- **Paint**
- **HVAC Controls and Conduit (only as stated above)**
- **Ansul System and Controls**
- **Equipment cords**

Sincerely,

Dustin Doyle

Dustin Doyle
Doyle Electric, LLC
512-743-5534

WILCO Jail Renovation - ASI 3

Item#	Description	Qty	Price	Price Unit	Ext Price	Labor	Labor Unit	Ext Labor
1001	3/4" EMT	670.00	139.54	C	934.92	5.50	C	36.85
1003	1-1/4" EMT	50.00	402.12	C	201.06	6.20	C	3.10
1050	1/2" GRC	100.00	543.26	C	543.26	5.00	C	5.00
1051	3/4" GRC	50.00	520.88	C	260.44	6.00	C	3.00
1052	1" GRC	80.00	772.39	C	617.91	6.20	C	4.96
1121	1/2" Steel Flex	130.00	91.61	C	119.09	4.00	C	5.20
1143	1/2" Liquidtight (metallic)	24.00	234.14	C	56.19	4.00	C	0.96
1144	3/4" Liquidtight (metallic)	36.00	318.44	C	114.64	5.00	C	1.80
1145	1" Liquidtight (metallic)	18.00	575.44	C	103.58	7.50	C	1.35
1328	1-1/4" EMT Elbow	3.00	608.05	C	18.24	0.32	E	0.96
1485	3/4" Compression Steel Connector	18.00	350.20	C	63.04	0.20	E	3.60
1487	1-1/4" Compression Steel Connector	6.00	1058.24	C	63.49	0.30	E	1.80
1565	3/4" Compression Steel Coupling	67.00	404.10	C	270.75	0.30	E	20.10
1567	1-1/4" Compression Steel Coupling	8.00	1117.90	C	89.43	0.50	E	4.00
1594	1/2" Locknut	20.00	33.29	C	6.66	0.10	E	2.00
1595	3/4" Locknut	12.00	43.59	C	5.23	0.12	E	1.44
1596	1" Locknut	12.00	76.39	C	9.17	0.14	E	1.68
1606	1/2" Plastic Bushing	10.00	23.18	C	2.32	0.10	E	1.00
1607	3/4" Plastic Bushing	6.00	31.32	C	1.88	0.12	E	0.72
1608	1" Plastic Bushing	6.00	49.62	C	2.98	0.14	E	0.84
1807	1/2" Cut & Thread	5.00	0.00	E	0.00	0.21	E	1.05
1808	3/4" Cut & Thread	3.00	0.00	E	0.00	0.25	E	0.75
1809	1" Cut & Thread	3.00	0.00	E	0.00	0.32	E	0.96
1830	1/2" GRC Coupling	10.00	160.44	C	16.04	0.10	E	1.00
1831	3/4" GRC Coupling	5.00	196.96	C	9.85	0.12	E	0.60
1832	1" GRC Coupling	8.00	294.00	C	23.52	0.16	E	1.28
1843	1/2" Die Cast Screw-In Flex Conn	16.00	118.25	C	18.92	0.12	E	1.92
1923	1/2" 90D LT Flex Conn w/Ins Throat	8.00	865.14	C	69.21	0.30	E	2.40
1924	3/4" 90D LT Flex Conn w/Ins Throat	10.00	1279.62	C	127.96	0.46	E	4.60
1925	1" 90D LT Flex Conn w/Ins Throat	6.00	2730.93	C	163.86	0.56	E	3.36
2338	1/2" 1-Hole Strap	16.25	29.68	C	4.82	4.00	C	0.65
2359	1/2" Conduit Hanger w/Bolt	15.50	71.83	C	11.13	25.00	C	3.88
2360	3/4" Conduit Hanger w/Bolt	100.50	83.10	C	83.52	25.00	C	25.13
2361	1" Conduit Hanger w/Bolt	12.25	97.20	C	11.91	25.00	C	3.06
2362	1-1/4" Conduit Hanger w/Bolt	6.25	115.55	C	7.22	27.50	C	1.72
2419	1/4" Beam Clamp	1.00	236.82	C	2.37	0.09	E	0.09
2420	1/2" Beam Clamp	4.00	1279.49	C	51.18	0.09	E	0.36
2471	4" Square x 2-1/8" Deep Box (1/2 & 3/4 KO's)	7.00	1724.90	C	120.74	0.30	E	2.10
2479	1G WP Bell Box-(3)1/2" Hubs	1.00	1744.81	C	17.45	0.90	E	0.90
2481	1G WP Bell Box-(3)3/4" Hubs	3.00	1917.74	C	57.53	1.10	E	3.30
2486	2G WP Bell Box-(4)3/4" Hubs	2.00	3834.96	C	76.70	1.35	E	2.70
2489	2G WP Bell Box-(4)1" Hubs	4.00	2270.76	C	90.83	0.75	E	3.00
2661	#10 THHN CU Stranded Wire	900.00	253.66	M	228.29	7.50	M	6.75
2663	#6 THHN CU Stranded Wire	2744.00	612.64	M	1681.08	12.00	M	32.93
2681	#12 THHN CU Solid Wire	1033.20	143.02	M	147.77	6.00	M	6.20
2682	#10 THHN CU Solid Wire	5634.30	226.12	M	1274.03	7.50	M	42.26
3277	60A/3P 600V HD NF Safety Sw-Nema 1	1.00	74.12	E	74.12	2.70	E	2.70
3945	30A 2P 120/240V Bolt-On Circuit Breaker	2.00	147.24	E	294.48	0.50	E	1.00
3962	60A 3P 120/240V Bolt-On Circuit Breaker	1.00	147.24	E	147.24	1.10	E	1.10
4050	60A 3P 277V Bolt-On Circuit Breaker	2.00	291.12	E	582.24	1.20	E	2.40
4410	#8-6 Wire Termination Labor	32.00	0.00	E	0.00	0.26	E	8.32
4713	20A/125V Prem Spec Grde GFI/Tamper Resistant (5-20	47.00	17.45	E	820.15	0.35	E	16.45
4972	1G SS Blank Plate	34.00	266.20	C	90.51	0.10	E	3.40
4973	1G SS Decora/GFI Plate	44.00	472.04	C	207.70	0.20	E	8.80
5057	1G WP Blank Cover	2.00	393.92	C	7.88	0.20	E	0.40
5063	2G WP Blank Cover	4.00	821.92	C	32.88	0.26	E	1.04
5065	2G WP In Use GFI Cover	3.00	12.15	E	36.45	0.20	E	0.60
5079	4" Square Flat Blank Cover	11.00	402.74	C	44.30	0.12	E	1.32

5744	4x4x4" Screw Cover Pull Box-Nema 1	1.00	13.32	E	13.32	0.96	E	0.96
5932	Unistrut (Deep)	20.00	755.56	C	151.11	20.00	C	4.00
5940	Hex Head Cap Screw 1/4 Inch X 1-1/2 Inch Zinc Plat	4.00	72.33	C	2.89	20.00	C	0.80
5943	1/4" Flat Washer	2.00	84.47	C	1.69	0.03	E	0.06
6133	Red Wirenuts	174.00	145.79	M	25.37	3.50	C	6.09
6135	Blue Wirenuts	8.00	63.44	C	5.08	5.25	C	0.42
6165	1/4" Concrete Anchor	163.00	105.89	C	172.60	16.00	C	26.08
6198	1" x 3/4" RE Bushing	4.00	3.71	E	14.84	0.02	E	0.08
9946	Remove #10 wire (per foot)	800.00	0.00	E	0.00	0.50	C	4.00
9950	Remove #3 wire (per foot)	540.00	0.00	E	0.00	0.76	C	4.10
BAKERY	60A/3P 600V HD NF Safety Sw-Nema 1	2.00	74.12	E	148.24	2.70	E	5.40
T0001	Rework Bakery	3.00	0.00	E	0.00	2.00	E	6.00
T0002	Rework Slicer Area	2.00	0.00	E	0.00	3.00	E	6.00
T0003	Existing Conduit/Chipping Reuse	2.00	0.00	E	0.00	3.00	E	6.00
T0004	Concrete/CMU rework at hood half/wall	1.00	0.00	E	0.00	16.00	E	16.00
T0005	Tamper Proof Hardware	1.00	75.30	E	75.30	3.00	E	3.00
T0006	Control for Dishwasher/Oven	2.00	0.00	E	0.00	2.00	E	4.00
T0007	Tamper Resistant Driver	2.00	14.35	E	28.70	0.00	E	0.00
					Total	\$10,757.30	Total	393.83 Hrs

Change Order Summary	
Material Total	\$10,757.30
Material Subtotal	\$10,757.30
Electrician Hours	295.37
Electrician per Hour Including Burden	\$33.12
Superintendent Hours	98.46
Superintendent per Hour Including Burden	\$56.05
Labor Subtotal	\$15,301.34
Consumables (6% of material)	\$645.44
Project Management (5% of labor)	\$765.07
Safety (\$0.50 per labor hour)	\$196.92
Equipment	\$0.00
Subcontractors	\$0.00
Direct Costs Subtotals	\$1,607.42
Total Costs Subtotal	\$27,666.06
Overhead and Profit (15%)	\$4,149.91
CHANGE ORDER TOTAL	\$31,816



Cust # 147812

3203 Longhorn Blvd, Ste 101
 Austin, TX 78758
 (512)927-7100 Fax (512)927-7104

Quote

Salesrep	RG	Quote #	3291326-00
Quote Date	02/14/18	PO #	WILLIAMSON CO.
		Page #	1
Date and Time Printed			
02/14/18 03:56 PM			

Ship To WILLIAMSON COUNTY JAIL RENO
 C/O DOYLE ELECTRIC
 306 W 4TH ST
 GEORGETOWN, TX 78626

Correspondence To THE REYNOLDS COMPANY
 P.O. BOX 205653
 DALLAS, TX 75320-5653

Bill To DOYLE ELECTRIC, LLC
 1108 S. LAKESIDE DR
 BURNET, TX 78611

Instructions

Ship Point	Via	Terms
The Reynolds Company - AUS	DO NOT SHIP	1%10daysN30

QUOTES ARE VALID FOR 30 DAYS ONLY

Pricing firm for 24 hrs. Subject to change based upon raw material cost.

Ln #	Product And Description	Quantity Quoted	Quantity Backordered	Quantity Available	Unit Price	Price UM	Amount (Net)
1	GEDITHN3361 GE THN3361 30A-600V-3PNF SW https://www.reynoldsonline.com/Search/78316401130	3	1	2	74.12	E	222.36
2	SIEMB360 ITE B360 3P 60A CKT BRKR https://www.reynoldsonline.com/Search/78364326376	1	1	0	147.24	E	147.24
3	SIEMBQD360 ITE BQD360 3P 60A 277/480 CB https://www.reynoldsonline.com/Search/78364327742	2	2	0	291.12	E	582.24
3	Lines Total			6		Subtotal	951.84
						Quote Total	951.84

Tom Stanfield

From: Dustin Doyle <dustind@doyleelectrictx.com>
Sent: Friday, February 16, 2018 10:51 AM
To: 'Tom Stanfield'
Cc: 'Jason Cox'
Subject: FW: ASI 3 - DE CO 516-03.pdf
Attachments: ASI 3 - DE CO 516-03.pdf

Tom,
Per our conversation, below is the break out for working days.

Wire Demo/Pulling (4 men x 3 days) = 96 hours
Conduit/Rework (2 men x 19 days) = 304 Hours
Mobilization/waiting on kitchen subs to install (Added 2 Days slack)

Total Days = 24 days

Sincerely,

Dustin Doyle
512-743-5534
Doyle Electric, LLC
TECL #32035

From: Dustin Doyle [<mailto:dustind@doyleelectrictx.com>]
Sent: Thursday, February 15, 2018 11:03 AM
To: 'Tom Stanfield' <toms@strconstructors.com>
Cc: 'Jason Cox' <jasonc@doyleelectrictx.com>
Subject: ASI 3 - DE CO 516-03.pdf

Tom,
Please see the attached. Please send written notice to proceed and approval of price for work to begin.

As always, call with any questions or concerns.

Sincerely,

Dustin Doyle
512-743-5534
Doyle Electric, LLC
TECL #32035

Williamson County Facilities - Job Cost Tracking Log

Project: Jail Kitchen Remodel P411

Change Order #: 5

Change Order No.	Court Agenda Date	Party of Initiation	Time Ext. (Days)	Cost of Work	Owner Contingency	Total Updated Contract Amount
Contract			180	\$ 1,781,645.00	\$ 450,000.00	\$ 2,231,645.00
1	12/12/2017	Architect	10	\$ 118,633.53	\$ (118,633.53)	\$ 2,231,645.00
2	2/20/2018		8	\$ 42,482.97	\$ (42,482.97)	\$ 2,231,645.00
3			2	\$ 49,389.05	\$ (49,389.05)	\$ 2,231,645.00
4			0	\$ 37,632.70	\$ (37,632.70)	\$ 2,231,645.00
5			19	\$ 83,476.43	\$ (83,476.43)	\$ 2,231,645.00
Total			219	\$ 2,113,259.68	\$ 118,385.32	

Commissioners Court - Regular Session

35.

Meeting Date: 02/27/2018

Discuss consider and take appropriate action on a revised Resolution for the TxDOT Advance Funding Agreement for the CR 456 truss bridge

Submitted For: Terron Evertson

Submitted By: Kelly Murphy, Infrastructure

Department: Infrastructure

Agenda Category: Regular Agenda Items

Information

Agenda Item

Discuss, consider and take appropriate action on a revised Resolution for the TxDOT Advance Funding Agreement for Bridge Replacement or Rehabilitation Off the State System in regards to the CR 456 truss bridge in Coupland.

Background

The Commissioners Court previously approved the Advance Funding Agreement and the original Resolution at its November 21, 2017 session. Texas Department of Transportation is now requiring a revised Resolution to be approved and executed to signify authority for the County Judge to sign the Advance Funding Agreement.

Fiscal Impact

From/To	Acct No.	Description	Amount
---------	----------	-------------	--------

Attachments

[Resolution- CR 456 bridge AFA](#)

[AFA- CR 456 bridge](#)

Form Review

Inbox

County Judge Exec Asst.
Form Started By: Kelly Murphy
Final Approval Date: 02/22/2018

Reviewed By

Wendy Coco

Date

02/22/2018 09:58 AM
Started On: 02/22/2018 09:27 AM

STATE OF TEXAS

*

*THE COMMISSIONERS COURT
OF*

COUNTY OF WILLIAMSON

*

WILLIAMSON COUNTY, TEXAS

KNOW ALL MEN BY THESE PRESENT that on this, the 27th day of February, 2018, the Commissioners Court of Williamson County, Texas, met in duly called session at the Courthouse in Georgetown, Texas and at said meeting, among other business, the Court considered the following.

RESOLUTION:

WHEREAS, it has been determined by the State of Texas Department of Transportation that the certain bridge located in a segment of CR 456 at Brushy Creek located within the County of Williamson and being known as NBI Structure #14-246-0-AA04-10-001 does not meet the minimum standards for such bridgework and that under such conditions that the bridge must be improved to meet required Department and Federal standards; and

WHEREAS, the federal off-system bridge program is administered by the State to replace or rehabilitate structurally deficient bridges located on public roads off the designated state highway system; and

WHEREAS, the project to remedy the said bridge is included in the currently approved off-state system federal-aid Highway Bridge Replacement and Rehabilitation Program (HBRRP) as authorized by Texas Transportation Commission Minute Order Number 115005, dated August 2017; and

WHEREAS, the estimated local match fund participation requirement on this structure has already been met, and no additional funding for said improvements is required of Williamson County, and

WHEREAS, an Advance Funding Agreement with TxDOT for Bridge Replacement or Rehabilitation Off the State System which would benefit the citizens of Williamson County.

THEREFORE, BE IT RESOLVED that the Local Government approves the Title 23 United States Code Section 144 authorizing federal funds to assist the states in the replacement or rehabilitation of deficient bridges located on public highways, roads and streets, including those under the jurisdiction of local governments.

Now therefore, the Williamson County Commissioners Court does hereby enter into this agreement with the Texas Department of Transportation.

RESOLVED this ___ day of _____, 201_.

Dan A. Gattis, County Judge

Attest:

Nancy E. Rister, County Clerk

CSJ # 0914-05-181
District #14 - Austin
Code Chart 64 #50246
Project: CR 456 @ Brushy Creek
NBI Structure #14-246-0-AA04-10-001
Federal Highway Administration
CFDA Title: Highway and Construction
CFDA No.: 20.205
Not Research and Development

STATE OF TEXAS §

COUNTY OF TRAVIS §

**ADVANCE FUNDING AGREEMENT
For Bridge Replacement or Rehabilitation
Off the State System**

THIS Advance Funding Agreement (the Agreement) is made by and between the State of Texas, acting by and through the Texas Department of Transportation, called the "State", and the County of Williamson, acting by and through its duly authorized officials, called the "Local Government."

WITNESSETH

WHEREAS, Title 23 United States Code Section 144 authorizes federal funds to assist the states in the replacement or rehabilitation of deficient bridges located on public highways, roads, and streets, including those under the jurisdiction of local governments; and

WHEREAS, the Texas Transportation Code Sections 201.103 and 222.052 establish that the State shall plan and make policies for the construction of a comprehensive system of state highways and public roads in cooperation with local governments; and

WHEREAS, the Local Government owns one or more bridges on a public road or street located at CR 456, and these bridges are included in the currently approved off-state system federal-aid Highway Bridge Replacement and Rehabilitation Program (HBRRP) as authorized by Texas Transportation Commission Minute Order Number _____, dated _____, 20__; and

WHEREAS, the State has requested that the Local Government grant the State access to its right-of-way to rehabilitate the bridge located at CR 456 at Brushy Creek, at no cost to the Local Government; and,

WHEREAS, the Governing Body of the Local Government has approved entering into this Agreement by resolution or ordinance, which is attached to and made a part of this agreement as Attachment A for the development of the specific programmed replacement or rehabilitation project, called the "Project". The Project is identified in the location map shown as Attachment B, which is attached to and made a part of this agreement.

CSJ # 0914-05-181
District #14 - Austin
Code Chart 64 #50246
Project: CR 456 @ Brushy Creek
NBI Structure #14-246-0-AA04-10-001
Federal Highway Administration
CFDA Title: Highway and Construction
CFDA No.: 20.205
Not Research and Development

NOW, THEREFORE, in consideration of the premises and of the mutual covenants and agreements of the parties, to be by them respectively kept and performed as set forth, it is agreed as follows:

AGREEMENT

1. Period of this Agreement

This Agreement becomes effective when signed by the last party whose signing makes the Agreement fully executed. This Agreement shall remain in effect until terminated as provided in Article 2.

2. Termination of this Agreement

This Agreement shall remain in effect until the Project is completed and accepted by all parties, unless:

- A.** The Agreement is terminated in writing with the mutual consent of the parties;
- B.** The Agreement is terminated by one party because of a breach, in which case any cost incurred because of the breach shall be paid by the breaching party;
- C.** The Local Government elects not to develop the project and the project does not proceed, in which case the Local Government agrees to reimburse the State for one-hundred percent (100%) of its reasonable actual direct and indirect costs incurred for the project; or
- D.** The project is inactive for thirty-six (36) months or longer and no expenditures have been charged against federal funds, in which case the State may at its discretion terminate the agreement.

3. Amendments

Amendments to this Agreement may be made due to changes in the character of the work, the terms of the Agreement, or the responsibilities of the parties. Amendments shall be enacted through a mutually agreed upon written amendment executed by all parties to this Agreement.

4. Remedies

This Agreement shall not be considered as specifying the exclusive remedy for any Agreement default, but all remedies existing at law and in equity may be availed of by either party to this Agreement and shall be cumulative.

5. Scope of Work

The scope of work for this Agreement is the replacement or rehabilitation of the bridges identified in the recitals of this Agreement. This replacement or rehabilitation

CSJ # 0914-05-181
District #14 - Austin
Code Chart 64 #50246
Project: CR 456 @ Brushy Creek
NBI Structure #14-246-0-AA04-10-001
Federal Highway Administration
CFDA Title: Highway and Construction
CFDA No.: 20.205
Not Research and Development

shall be accomplished in the manner described in the plans, specifications, and estimates developed in accordance with this Agreement and which are incorporated in this agreement by reference.

6. Right of Way and Real Property

- A. The Local Government is responsible for the provision and acquisition of all necessary right of way and will not be reimbursed with federal or state funds for the required right of way.
- B. The Local Government authorizes the State, its consultant, contractor, or other designated representative to enter the sites of these bridges and adjacent right of way or relocation right of way to perform surveys, inspections, construction, and other activities necessary to replace or rehabilitate these bridges and approaches.

7. Adjustment of Utilities

The Local Government shall be responsible for the adjustment, removal, or relocation of utility facilities in accordance with applicable state laws, regulations, rules, policies, and procedures, including any cost to the State of a delay resulting from the Local Government's failure to ensure that utility facilities are adjusted, removed, or relocated before the scheduled beginning of construction. The Local Government will not be reimbursed with federal or state funds for the cost of required utility work. The Local Government must obtain advance approval for any variance from established procedures. Before a construction contract is let, the Local Government shall provide, at the State's request, a certification stating that the Local Government has completed the adjustment of all utilities that must be adjusted before construction is completed.

8. Environmental Assessment and Mitigation

Development of the Project must comply with the National Environmental Policy Act and the National Historic Preservation Act of 1966, which require environmental clearance of federal-aid projects.

- A. The State is responsible for the identification and assessment of any environmental problems associated with the development of the Project governed by this Agreement.
- B. Cost participation in environmental assessment and remediation work shall be paid by the parties in the same ratio as construction costs and will be included in the construction costs identified in Attachment D, Estimate of Direct Costs.
- C. The State is responsible for providing any public meetings or public hearings required for development of the environmental assessment.
- D. The State will not begin construction of the Project until identified environmental problems have been remediated, unless provided for otherwise.

CSJ # 0914-05-181
District #14 - Austin
Code Chart 64 #50246
Project: CR 456 @ Brushy Creek
NBI Structure #14-246-0-AA04-10-001
Federal Highway Administration
CFDA Title: Highway and Construction
CFDA No.: 20.205
Not Research and Development

9. Compliance with Texas Accessibility Standards and ADA

All parties to this Agreement shall ensure that the plans for and the construction of the Project subject to this Agreement are in compliance with the Texas Accessibility Standards (TAS) issued by the Texas Department of Licensing and Regulation, under the Architectural Barriers Act, Article 9102, Texas Civil Statutes. The TAS establishes minimum accessibility requirements to be consistent with minimum accessibility requirements of the Americans with Disabilities Act (P.L. 101-336) (ADA).

10. Architectural and Engineering Services

The State is responsible for performance of any required architectural or preliminary engineering work. The Local Government may review and comment on the work as required to accomplish the public purposes of the Local Government. The State will cooperate fully with the Local Government in accomplishing these local public purposes to the degree permitted by state and federal law. The Local Government review shall not unduly delay the development of the Project.

11. Construction Responsibilities

- A. The State shall advertise for construction bids, issue bid proposals, receive and tabulate the bids, and award and administer the contract for construction of the Project. Administration of the contract includes the responsibility for construction engineering and for issuance of any change orders, supplemental agreements, amendments, or additional work orders that may become necessary subsequent to the award of the construction contract. In order to ensure federal funding eligibility, projects must be authorized by the State prior to advertising for construction.
- B. Upon completion of the Project, the State will issue a "Notification of Completion" acknowledging the Project's construction completion.

12. Project Maintenance

After the Project has been completed, the Local Government shall accept full ownership, and operate and maintain the facilities authorized by this Agreement for the benefit of and at no charge of toll to the public. This covenant shall survive the completion of construction under this Agreement.

13. Local Project Sources and Uses of Funds

- A. A Project Cost Estimate is provided in Attachment D, Estimate of Direct Costs.
- B. Attachment D provides a source of funds estimate as well as the estimated direct preliminary engineering, construction engineering, and construction costs for the Project in total and by the Local Government.

CSJ # 0914-05-181
District #14 - Austin
Code Chart 64 #50246
Project: CR 456 @ Brushy Creek
NBI Structure #14-246-0-AA04-10-001
Federal Highway Administration
CFDA Title: Highway and Construction
CFDA No.: 20.205
Not Research and Development

- C. The required Local Government participation is based solely upon the State's estimate of the eligible work at the time this Agreement is executed and will not be adjusted during construction except as needed to include any Project cost item or portion of a cost item ineligible for state or federal participation. The Local Government is responsible for the direct cost of any project cost item or portion of a cost item that is not eligible for federal participation under the federal HBRRP. The Local Government is also responsible for any cost resulting from changes made at the request of the Local Government. The State and the Federal Government will not reimburse the Local Government for any work performed before federal spending authority is formally obligated to the Project by the Federal Highway Administration. After federal funds have been obligated, the State will send to the Local Government a copy of the formal documentation showing the obligation of funds including federal award information.
- D. If the Local Government will perform any work under this contract for which reimbursement will be provided by or through the State, the Local Government must complete training before federal spending authority is obligated. Training is complete when at least one individual who is working actively and directly on the Project successfully completes and receives a certificate for the course entitled *Local Government Project Procedures Qualification for the Texas Department of Transportation*. The Local Government shall provide the certificate of qualification to the State. The individual who receives the training certificate may be an employee of the Local Government or an employee of a firm that has been contracted by the Local Government to perform oversight of the Project. The State in its discretion may deny reimbursement if the Local Government has not designated a qualified individual to oversee the Project.
- E. After execution of this Agreement, but thirty (30) days prior to the performance of any work by the State, the Local Government shall remit to the State the amount specified in Attachment D for the Local Government's contribution for preliminary engineering. The Local Government will pay, at a minimum, its funding share for this estimated cost of preliminary engineering.
- F. Forty-five (45) days prior to the date set for receipt of the construction bids, the Local Government shall remit its remaining financial share for the State's estimated construction oversight and construction costs and any other costs owed.
- G. If, at the completion or termination of the Project, the State determines that additional funding is required by the Local Government, the State shall notify the Local Government in writing. The Local Government shall make payment to the State within thirty (30) days from receipt of the State's written notification.
- H. Whenever funds are paid by the Local Government to the State under this Agreement, the Local Government shall remit a check or warrant made payable to the "Texas Department of Transportation". The check or warrant shall be

CSJ # 0914-05-181
District #14 - Austin
Code Chart 64 #50246
Project: CR 456 @ Brushy Creek
NBI Structure #14-246-0-AA04-10-001
Federal Highway Administration
CFDA Title: Highway and Construction
CFDA No.: 20.205
Not Research and Development

deposited by the State and managed by the State. The funds may only be applied to the State Project.

- I. Upon completion of the Project, the State will perform an audit of the Project costs. Any funds due to the Local Government, the State, or the Federal Government will be promptly paid by the owing party.
- J. The State will not pay interest on any funds provided by the Local Government.
- K. The Local Government funding participation responsibilities include Project direct costs only, except when the Project is terminated before completion at the request of the Local Government as addressed in the Termination provision of this Agreement.
- L. The amounts shown on Attachment D are estimates only. If actual costs exceed the estimates, this shall be considered a fixed price agreement, and no additional funding shall be required of the Local Government except to the extent that the additional costs result from changes made at the request of the Local Government or to the extent that the additional costs are not eligible for federal participation under the federal HBRRP. If actual costs are less than the estimates, Local Government participation shall be recalculated based on actual costs. If the recalculation results in a reduction in participation by the Local Government, the State shall pay the difference to the Local Government upon completion of the Project.
- M. Under the provisions of Texas Transportation Code Section 222.053 certain counties qualify as Economically Disadvantaged Counties (EDC) in comparison to other counties in the state as below average per capita property value, below average per capita income, and above average unemployment, for certain years. If applicable, in consideration of such EDC status that may be applicable for the Project, the required local match fund participation has been adjusted to _____ percent (___%).
- N. The State will not execute the contract for the construction of a Project until the required funding has been made available by the Local Government in accordance with this Agreement.
- O. The state auditor may conduct an audit or investigation of any entity receiving funds from the State directly under this contract or indirectly through a subcontract under this contract. Acceptance of funds directly under this contract or indirectly through a subcontract under this contract acts as acceptance of the authority of the state auditor, under the direction of the legislative audit committee, to conduct an audit or investigation in connection with those funds. An entity that is the subject of an audit or investigation must provide the state auditor with access to any information the state auditor considers relevant to the investigation or audit.
- P. The Local Government is authorized to submit requests for reimbursement by submitting the original of an itemized invoice in a form and containing all items

CSJ # 0914-05-181
District #14 - Austin
Code Chart 64 #50246
Project: CR 456 @ Brushy Creek
NBI Structure #14-246-0-AA04-10-001
Federal Highway Administration
CFDA Title: Highway and Construction
CFDA No.: 20.205
Not Research and Development

required by the State no more frequently than monthly, and no later than ninety (90) days after costs are incurred. If the Local Government submits invoices more than ninety (90) days after the costs are incurred, and if federal funding is reduced as a result, the State shall have no responsibility to reimburse the Local Government for those costs.

- 14. Performance by Local Government of Equivalent-Match Projects (EMP) in Return for Waiver of Local Match Participation Funding on Participation-Waived Projects (PWP)**
- A. Applicability.** If a request for waiver has been received and approved by the State's District Engineer, then the required ten percent matching fund participation or percent as adjusted for EDC consideration, as shown in Attachment D, Estimate of Direct Costs, but excluding ineligible costs under the bridge program, is waived. This waiver is based on the commitment of the Local Government to spend an equivalent amount of funds for structural or safety improvement on "other" bridge structures and other conditions as specified in 43 TAC Section 15.55(d). If a waiver has been granted, the Project shall be defined to be a PWP and the work on the "other" bridge structures that will be improved by the Local Government shall be defined to be the EMPs. Attachment C to this Agreement shows a list of EMPs under this Agreement.
 - B. Project Cost Estimate for PWP.** Attachment D to this Agreement shows the estimated direct preliminary engineering, construction engineering, and construction costs for the PWP in total and local match fund participation being waived or partially waived.
 - C. Credit Against EMP Work.** Any local match fund participation that has already been paid, or which the Local Government is agreeable to paying to the State, will be credited against EMP work to be performed by the Local Government. If applicable, this credit will be reflected in Attachment D to this Agreement.
 - D. Responsibilities of the Local Government on EMPs.**
 - 1. The Local Government shall be responsible for all engineering and construction, related costs, and compliance with all applicable state and federal environmental regulations and permitting requirements.
 - 2. The structural or safety improvement work on the EMPs shall be performed subsequent to the final execution of this Agreement but within three (3) calendar years after the earliest contract award of the related PWPs.
 - 3. Written documentation, suitable for audit, of the structural or safety improvement work completed on the EMPs shall be kept on file by the Local Government for four (4) years after completion of work or claims, lawsuits, or audits related to those items, whichever is longer. A notice of completion of work on the EMPs shall be delivered to the State's District Engineer no later than thirty (30) calendar days after work is completed on the EMPs.

CSJ # 0914-05-181
District #14 - Austin
Code Chart 64 #50246
Project: CR 456 @ Brushy Creek
NBI Structure #14-246-0-AA04-10-001
Federal Highway Administration
CFDA Title: Highway and Construction
CFDA No.: 20.205
Not Research and Development

- 4. Failure by the Local Government to adequately complete the EMPs within the stated three-year period shall result in the Local Government being excluded from receiving such waivers for a minimum of five (5) years.
- E. Funding of Ineligible or Additional Work Not Waived. Regardless of any waiver of eligible program costs, the Local Government shall pay the State one-hundred percent (100%) of the cost of any PWP item or portion of a cost item that is not eligible for federal or state participation, and one-hundred percent (100%) of the costs resulting from additional work on the PWP performed solely at the request of the Local Government. If the ineligible or additional work is preliminary engineering, the payment shall be made at least thirty (30) days prior to the beginning of preliminary engineering work on the PWP. If the ineligible or additional work is for construction or construction engineering, the payment shall be made at least forty-five (45) days prior to the date set for receipt of bids for construction of the PWP.

15. Notices

All notices to either party shall be delivered personally or sent by certified or U.S. mail, postage prepaid, addressed to that party at the following address:

State: Director, Bridge Division
Texas Department of Transportation
125 E. 11th Street
Austin, Texas 78701

Local Government: _____

All notices shall be deemed given on the date delivered in person or deposited in the mail, unless otherwise provided by this agreement. Either party may change the above address by sending written notice of the change to the other party. Either party may request in writing that notices shall be delivered personally or by certified U.S. mail, and that request shall be carried out by the other party.

16. Legal Construction

In case one or more of the provisions contained in this Agreement shall for any reason be held invalid, illegal, or unenforceable in any respect, such invalidity, illegality, or unenforceability shall not affect any other provisions and this Agreement shall be construed as if it did not contain the invalid, illegal, or unenforceable provision.

CSJ # 0914-05-181
District #14 - Austin
Code Chart 64 #50246
Project: CR 456 @ Brushy Creek
NBI Structure #14-246-0-AA04-10-001
Federal Highway Administration
CFDA Title: Highway and Construction
CFDA No.: 20.205
Not Research and Development

17. Responsibilities of the Parties

The parties to this Agreement agree that no party is an agent, servant, or employee of the other party and each party agrees it is responsible for its individual acts and deeds as well as the acts and deeds of its contractors, employees, representatives, and agents.

18. Ownership of Documents

Upon completion or termination of this Agreement, all documents prepared by the State shall remain the property of the State. All data prepared under this Agreement shall be made available to the State without restriction or limitation on their further use. All documents produced or approved or otherwise created by the Local Government shall be transmitted to the State in the form of photocopy reproduction on a monthly basis as required by the State. The originals shall remain the property of the Local Government. At the request of the State, the Local Government shall submit any information required by the State in the format directed by the State.

19. Compliance with Laws

The parties shall comply with all federal, state, and local laws, statutes, ordinances, rules and regulations, and the orders and decrees of any courts or administrative bodies or tribunals in any manner affecting the performance of this Agreement. When required, the Local Government shall furnish the State with satisfactory proof of this compliance.

20. Sole Agreement

This Agreement constitutes the sole and only agreement between the parties and supersedes any prior understandings or written or oral agreements respecting the subject matter of this Agreement.

21. Office of Management and Budget (OMB) Cost Principles

In order to be reimbursed with federal funds, the parties shall comply with the Cost Principles established in 2 CFR 200 that specify that all reimbursed costs are allowable, reasonable, and allocable to the Project.

22. Procurement and Property Management Standards

The parties shall adhere to the procurement standards established in Title 49 CFR §18.36 and with the property management standard established in Title 49 CFR §18.32.

CSJ # 0914-05-181
District #14 - Austin
Code Chart 64 #50246
Project: CR 456 @ Brushy Creek
NBI Structure #14-246-0-AA04-10-001
Federal Highway Administration
CFDA Title: Highway and Construction
CFDA No.: 20.205
Not Research and Development

23. Inspection of Books and Records

The parties to the Agreement shall maintain all books, documents, papers, accounting records, and other documentation relating to costs incurred under this Agreement and shall make such materials available to the State, the Local Government, and, if federally funded, the Federal Highway Administration (FHWA) and the U.S. Office of the Inspector General, or their duly authorized representatives, for review and inspection at its office during the contract period and for four (4) years from the date of completion of work defined under this contract or until any impending litigation or claims are resolved. Additionally, the State, the Local Government, the FHWA, and their duly authorized representatives shall have access to all the governmental records that are directly applicable to this Agreement for the purpose of making audits, examinations, excerpts, and transcriptions.

24. Civil Rights Compliance

- A. Compliance with Regulations: The Local Government will comply with the Acts and the Regulations relative to Nondiscrimination in Federally-assisted programs of the U.S. Department of Transportation (USDOT), the Federal Highway Administration (FHWA), as they may be amended from time to time, which are herein incorporated by reference and made part of this agreement.
- B. Nondiscrimination: The Local Government, with regard to the work performed by it during the contract, will not discriminate on the grounds of race, color, or national origin in the selection and retention of subcontractors, including procurement of materials and leases of equipment. The Local Government will not participate directly or indirectly in the discrimination prohibited by the Acts and the Regulations, including employment practices when the contract covers any activity, project, or program set forth in Appendix B of 49 CFR Part 21.
- C. Solicitations for Subcontracts, Including Procurement of Materials and Equipment: In all solicitations either by competitive bidding or negotiation made by the Local Government for work to be performed under a subcontract, including procurement of materials or leases of equipment, each potential subcontractor or supplier will be notified by the Local Government of the Local Government's obligations under this contract and the Acts and Regulations relative to Nondiscrimination on the grounds of race, color, or national origin.
- D. Information and Reports: The Local Government will provide all information and reports required by the Acts, the Regulations, and directives issued pursuant thereto, and will permit access to its books, records, accounts, other sources of information, and facilities as may be determined by the State or the FHWA to be pertinent to ascertain compliance with such Acts, Regulations or directives. Where any information required of the Local Government is in the exclusive possession of another who fails or refuses to furnish this information, the Local Government will

CSJ # 0914-05-181
District #14 - Austin
Code Chart 64 #50246
Project: CR 456 @ Brushy Creek
NBI Structure #14-246-0-AA04-10-001
Federal Highway Administration
CFDA Title: Highway and Construction
CFDA No.: 20.205
Not Research and Development

so certify to the State or the Federal Highway Administration, as appropriate, and will set forth what efforts it has made to obtain the information.

- E. Sanctions for Noncompliance: In the event of the Local Government's noncompliance with the Nondiscrimination provisions of this contract, the State will impose such contract sanctions as it or the FHWA may determine to be appropriate, including, but not limited to:
 - 1. withholding of payments to the Local Government under the contract until the Local Government complies and/or
 - 2. cancelling, terminating, or suspending of the contract, in whole or in part.
- F. Incorporation of Provisions: The Local Government will include the provisions of paragraphs (A) through (F) in every subcontract, including procurement of materials and leases of equipment, unless exempt by the Acts, the Regulations and directives issued pursuant thereto. The Local Government will take such action with respect to any subcontract or procurement as the State or the FHWA may direct as a means of enforcing such provisions including sanctions for noncompliance. Provided, that if the Local Government becomes involved in, or is threatened with, litigation with a subcontractor or supplier because of such direction, the Local Government may request the State to enter into such litigation to protect the interests of the State. In addition, the Local Government may request the United States to enter into such litigation to protect the interests of the United States.

25. Disadvantaged Business Enterprise (DBE) Program Requirements

- A. The parties shall comply with the Disadvantaged Business Enterprise Program requirements established in 49 CFR Part 26.
- B. The Local Government shall adopt, in its totality, the State's federally approved DBE program.
- C. The Local Government shall set an appropriate DBE goal consistent with the State's DBE guidelines and in consideration of the local market, project size, and nature of the goods or services to be acquired. The Local Government shall have final decision-making authority regarding the DBE goal and shall be responsible for documenting its actions.
- D. The Local Government shall follow all other parts of the State's DBE program referenced in TxDOT Form 2395, Memorandum of Understanding Regarding the Adoption of the Texas Department of Transportation's Federally-Approved Disadvantaged Business Enterprise by Entity and attachments found at web address http://ftp.dot.state.tx.us/pub/txdot-info/bop/dbe/mou/mou_attachments.pdf.
- E. The Local Government shall not discriminate on the basis of race, color, national origin, or sex in the award and performance of any U.S. Department of Transportation (DOT)-assisted contract or in the administration of its DBE program or the requirements of 49 CFR Part 26. The Local Government shall

CSJ # 0914-05-181
District #14 - Austin
Code Chart 64 #50246
Project: CR 456 @ Brushy Creek
NBI Structure #14-246-0-AA04-10-001
Federal Highway Administration
CFDA Title: Highway and Construction
CFDA No.: 20.205
Not Research and Development

take all necessary and reasonable steps under 49 CFR Part 26 to ensure non-discrimination in award and administration of DOT-assisted contracts. The State's DBE program, as required by 49 CFR Part 26 and as approved by DOT, is incorporated by reference in this agreement. Implementation of this program is a legal obligation and failure to carry out its terms shall be treated as a violation of this agreement. Upon notification to the Local Government of its failure to carry out its approved program, the State may impose sanctions as provided for under 49 CFR Part 26 and may, in appropriate cases, refer the matter for enforcement under 18 U.S.C. 1001 and the Program Fraud Civil Remedies Act of 1986 (31 U.S.C. 3801 et seq.).

- F. Each contract the Local Government signs with a contractor (and each subcontract the prime contractor signs with a sub-contractor) must include the following assurance: *The contractor, sub-recipient, or sub-contractor shall not discriminate on the basis of race, color, national origin, or sex in the performance of this contract. The contractor shall carry out applicable requirements of 49 CFR Part 26 in the award and administration of DOT-assisted contracts. Failure by the contractor to carry out these requirements is a material breach of this agreement, which may result in the termination of this agreement or such other remedy as the recipient deems appropriate.*

26. Debarment Certifications

The parties are prohibited from making any award at any tier to any party that is debarred or suspended or otherwise excluded from or ineligible for participation in Federal Assistance Programs under Executive Order 12549, "Debarment and Suspension." By executing this agreement, the Local Government certifies that it is not currently debarred, suspended, or otherwise excluded from or ineligible for participation in Federal Assistance Programs under Executive Order 12549 and further certifies that it will not do business with any party that is currently debarred, suspended, or otherwise excluded from or ineligible for participation in Federal Assistance Programs under Executive Order 12549. The parties to this contract shall require any party to a subcontract or purchase order awarded under this contract to certify its eligibility to receive Federal funds and, when requested by the State, to furnish a copy of the certification.

27. Lobbying Certification

In executing this Agreement, each signatory certifies to the best of that signatory's knowledge and belief, that:

- A. No federal appropriated funds have been paid or will be paid by or on behalf of the parties to any person for influencing or attempting to influence an officer or employee of any federal agency, a Member of Congress, an officer or employee of Congress, or an employee of a Member of Congress in connection with the

CSJ # 0914-05-181
District #14 - Austin
Code Chart 64 #50246
Project: CR 456 @ Brushy Creek
NBI Structure #14-246-0-AA04-10-001
Federal Highway Administration
CFDA Title: Highway and Construction
CFDA No.: 20.205
Not Research and Development

awarding of any federal contract, the making of any federal grant, the making of any federal loan, the entering into of any cooperative agreement, and the extension, continuation, renewal, amendment, or modification of any federal contract, grant, loan, or cooperative agreement.

- B. If any funds other than federal appropriated funds have been paid or will be paid to any person for influencing or attempting to influence an officer or employee of any agency, a Member of Congress, an officer or employee of Congress, or an employee of a Member of Congress in connection with federal contracts, grants, loans, or cooperative agreements, the signatory for the Local Government shall complete and submit the Federal Standard Form-LLL, "Disclosure Form to Report Lobbying," in accordance with its instructions.
- C. The parties shall require that the language of this certification be included in the award documents for all sub-awards at all tiers (including subcontracts, sub-grants, and contracts under grants, loans, and cooperative agreements) and all sub-recipients shall certify and disclose accordingly. Submission of this certification is a prerequisite for making or entering into this transaction imposed by Title 31 U.S.C. §1352. Any person who fails to file the required certification shall be subject to a civil penalty of not less than \$10,000 and not more than \$100,000 for each such failure.

28. Federal Funding Accountability and Transparency Act Requirements

- A. Any recipient of funds under this agreement agrees to comply with the Federal Funding Accountability and Transparency Act (FFATA) and implementing regulations at 2 CFR Part 170, including Appendix A. This agreement is subject to the following award terms: <http://www.gpo.gov/fdsys/pkg/FR-2010-09-14/pdf/2010-22705.pdf> and <http://www.gpo.gov/fdsys/pkg/FR-2010-09-14/pdf/2010-22706.pdf>.
- B. The Local Government agrees that it shall:
 - 1. Obtain and provide to the State, a Central Contracting Registry (CCR) number (Federal Acquisition Regulation, Part 4, Sub-part 4.1100) if this award provides for more than \$25,000 in Federal funding. The CCR number may be obtained by visiting the CCR web-site whose address is: <https://www.sam.gov/portal/public/SAM/>;
 - 2. Obtain and provide to the State a Data Universal Numbering System (DUNS) number, a unique nine-character number that allows the federal government to track the distribution of federal money. The DUNS number may be requested free of charge for all businesses and entities required to do so by visiting the Dun & Bradstreet (D&B) on-line registration website <http://fedgov.dnb.com/webform/>; and
 - 3. Report the total compensation and names of its top five (5) executives to the State if:

CSJ # 0914-05-181
District #14 - Austin
Code Chart 64 #50246
Project: CR 456 @ Brushy Creek
NBI Structure #14-246-0-AA04-10-001
Federal Highway Administration
CFDA Title: Highway and Construction
CFDA No.: 20.205
Not Research and Development

- i. More than 80% of annual gross revenues are from the Federal government, and those revenues are greater than \$25,000,000; and
- ii. The compensation information is not already available through reporting to the U.S. Securities and Exchange Commission.

29. Successors and Assigns

The State and the Local Government each binds itself, its successors, executors, assigns, and administrators to the other party to this Agreement and to the successors, executors, assigns, and administrators of such other party in respect to all covenants of this Agreement.

30. Local Government Restrictions

In the case that the Local Government has an existing, future, or proposed local ordinance, commissioners court order, rule, policy, or other directive that is more restrictive than the state or federal regulations that results in an increase cost to the State for the project, the local government is responsible for all increased costs associated with the ordinance, order, policy, directive, or change.

31. Single Audit Report

- A. The parties shall comply with the requirements of the Single Audit Act of 1984, P.L. 98-502, ensuring that the single audit report includes the coverage stipulated in 2 CFR 200.
- B. If threshold expenditures of \$750,000 or more are met during the fiscal year, the Local Government must submit a Single Audit Report and Management Letter (if applicable) to TxDOT's Compliance Division, 125 East 11th Street, Austin, TX 78701 or contact TxDOT's Compliance Division at singleaudits@txdot.gov.
- C. If expenditures are less than the threshold during the Local Government's fiscal year, the Local Government must submit a statement to TxDOT's Compliance Division as follows: "We did not meet the \$_____ expenditure threshold and therefore, are not required to have a single audit performed for FY_____."
- D. For each year the project remains open for federal funding expenditures, the Local Government will be responsible for filing a report or statement as described above. The required annual filing shall extend throughout the life of the agreement, unless otherwise amended or the project has been formally closed out and no charges have been incurred within the current fiscal year.

CSJ # 0914-05-181
District #14 - Austin
Code Chart 64 #50246
Project: CR 456 @ Brushy Creek
NBI Structure #14-246-0-AA04-10-001
Federal Highway Administration
CFDA Title: Highway and Construction
CFDA No.: 20.205
Not Research and Development

32. Pertinent Non-Discrimination Authorities

During the performance of this contract, the Local Government, for itself, its assignees, and successors in interest agree to comply with the following nondiscrimination statutes and authorities; including but not limited to:

- A. Title VI of the Civil Rights Act of 1964 (42 U.S.C. § 2000d et seq., 78 stat. 252), (prohibits discrimination on the basis of race, color, national origin); and 49 CFR Part 21.
- B. The Uniform Relocation Assistance and Real Property Acquisition Policies Act of 1970, (42 U.S.C. § 4601), (prohibits unfair treatment of persons displaced or whose property has been acquired because of Federal or Federal-aid programs and projects).
- C. Federal-Aid Highway Act of 1973, (23 U.S.C. § 324 et seq.), as amended, (prohibits discrimination on the basis of sex).
- D. Section 504 of the Rehabilitation Act of 1973, (29 U.S.C. § 794 et seq.) as amended, (prohibits discrimination on the basis of disability); and 49 CFR Part 27.
- E. The Age Discrimination Act of 1975, as amended, (49 U.S.C. § 6101 et seq.), (prohibits discrimination on the basis of age).
- F. Airport and Airway Improvement Act of 1982, (49 U.S.C. Chapter 471, Section 47123), as amended, (prohibits discrimination based on race, creed, color, national origin, or sex).
- G. The Civil Rights Restoration Act of 1987, (PL 100-209), (Broadened the scope, coverage and applicability of Title VI of the Civil Rights Act of 1964, The Age Discrimination Act of 1975 and Section 504 of the Rehabilitation Act of 1973, by expanding the definition of the terms "programs or activities" to include all of the programs or activities of the Federal-aid recipients, subrecipients and contractors, whether such programs or activities are Federally funded or not).
- H. Titles II and III of the Americans with Disabilities Act, which prohibits discrimination on the basis of disability in the operation of public entities, public and private transportation systems, places of public accommodation, and certain testing entities (42 U.S.C. §§ 12131-12189) as implemented by Department of Transportation regulations at 49 C.F.R. parts 37 and 38.
- I. The Federal Aviation Administration's Nondiscrimination statute (49 U.S.C. § 47123) (prohibits discrimination on the basis of race, color, national origin, and sex).
- J. Executive Order 12898, Federal Actions to Address Environmental Justice in Minority Populations and Low-Income Populations, which ensures nondiscrimination against minority populations by discouraging programs, policies, and activities with disproportionately high and adverse human health or environmental effects on minority and low-income populations.

CSJ # 0914-05-181
District #14 - Austin
Code Chart 64 #50246
Project: CR 456 @ Brushy Creek
NBI Structure #14-246-0-AA04-10-001
Federal Highway Administration
CFDA Title: Highway and Construction
CFDA No.: 20.205
Not Research and Development

- K. Executive Order 13166, Improving Access to Services for Persons with Limited English Proficiency, and resulting agency guidance, national origin discrimination includes discrimination because of limited English proficiency (LEP). To ensure compliance with Title VI, the parties must take reasonable steps to ensure that LEP persons have meaningful access to the programs (70 Fed. Reg. at 74087 to 74100).
- L. Title IX of the Education Amendments of 1972, as amended, which prohibits the parties from discriminating because of sex in education programs or activities (20 U.S.C. 1681 et seq.).

33. Signatory Warranty

Each signatory warrants that the signatory has necessary authority to execute this agreement on behalf of the entity represented.

CSJ # 0914-05-181
District #14 - Austin
Code Chart 64 #50246
Project: CR 456 @ Brushy Creek
NBI Structure #14-246-0-AA04-10-001
Federal Highway Administration
CFDA Title: Highway and Construction
CFDA No.: 20.205
Not Research and Development

THIS AGREEMENT IS EXECUTED by the State and the Local Government in duplicate.

THE LOCAL GOVERNMENT

Valerie Covey
Signature

Valerie Covey
Typed or Printed Name

County Commissioner, Pct 3
Title

11/21/17
Date

THE STATE OF TEXAS

Gregg A. Freeby, P.E.
Director, Bridge Division
Texas Department of Transportation

Date

CSJ # 0914-05-181
District #14 - Austin
Code Chart 64 #50246
Project: CR 456 @ Brushy Creek
NBI Structure #14-246-0-AA04-10-001
Federal Highway Administration
CFDA Title: Highway and Construction
CFDA No.: 20.205
Not Research and Development

ATTACHMENT A
RESOLUTION OR ORDINANCE OF LOCAL GOVERNMENT

CSJ # 0914-05-181
District #14 - Austin
Code Chart 64 #50246
Project: CR 456 @ Brushy Creek
NBI Structure #14-246-0-AA04-10-001
Federal Highway Administration
CFDA Title: Highway and Construction
CFDA No.: 20.205
Not Research and Development

**ATTACHMENT B
PROJECT LOCATION MAP**



CSJ # 0914-05-181
 District #14 - Austin
 Code Chart 64 #50246
 Project: CR 456 @ Brushy Creek
 NBI Structure #14-246-0-AA04-10-001
 Federal Highway Administration
 CFDA Title: Highway and Construction
 CFDA No.: 20.205
 Not Research and Development

**ATTACHMENT D
 ESTIMATE OF DIRECT COSTS**

	<u>Estimated Cost</u>	<u>Local Government Participation</u>
Preliminary Engineering (PE)	(1) <u>\$170,200</u>	
Ten Percent (10%) or EDC Adjusted Percent of PE for Local Government Participation		(3) <u>\$0</u>
Construction	<u>\$740,000</u>	
Engineering and Contingency (E&C)	<u>\$107,300</u>	
The Sum of Construction and E&C	(2) <u>\$847,300</u>	
Ten Percent (10%) or EDC Adjusted Percent of the Sum of Construction and E&C for Local Government Participation		(4) <u>\$0</u>
Amount of Advance Funds Paid by Local Government *		(5) <u>\$0</u>
Amount of Advance Funds to be Paid by Local Government *		(6) <u>\$0</u>
Balance of Local Government Participation which is to be Waived where the Project is a PWP		(3+4-5-6) <u>\$0</u>
Total Project Direct Cost	(1+2) <u>\$1,017,500</u>	

*Credited Against Local Government Participation Amount

If this Project is to be a PWP, Amount of EMP Work Being Credited to this PWP as Shown
 on Attachment C. \$0

Commissioners Court - Regular Session

36.

Meeting Date: 02/27/2018

CR 200 Contract

Submitted For: Charlie Crossfield

Submitted By: Charlie Crossfield, Road Bond

Department: Road Bond

Agenda Category: Regular Agenda Items

Information

Agenda Item

Discuss, consider and take appropriate action on a real estate contract with Daniel and Crystal Corbell for right of way needed on CR 200 (Parcel 22). Funding Source Road Bonds P285

Background

Fiscal Impact

From/To	Acct No.	Description	Amount
---------	----------	-------------	--------

Attachments

Corbell Contract

Form Review

Inbox

County Judge Exec Asst.

Form Started By: Charlie Crossfield

Final Approval Date: 02/22/2018

Reviewed By

Wendy Coco

Date

02/22/2018 09:58 AM

Started On: 02/22/2018 09:42 AM

REAL ESTATE CONTRACT
CR 200 Right of Way—Parcel 22

THIS REAL ESTATE CONTRACT (“Contract”) is made by DANIEL BLAKE CORBELL and CRYSTAL FAYTH CORBELL (referred to collectively in this Contract as “Seller”) and WILLIAMSON COUNTY, TEXAS (referred to in this Contract as “Purchaser”), upon the terms and conditions set forth in this Contract.

ARTICLE I
PURCHASE AND SALE

By this Contract, Seller sells and agrees to convey, and Purchaser purchases and agrees to pay for, the tract of land described as follows:

All of that certain 0.063-acre (2,749 square feet) tract of land out of Lot 72, Cierra Vista Subdivision, a Plat Recorded in Document No. 2007078025 of the Official Public Records of Williamson County, Texas (O.P.R.W.C.) and in Cabinet DD, Slide 314 of the Plat Records of Williamson County, Texas, said Lot 72 being conveyed to Daniel B. Corbell and wife Crystal F. Corbell by Deed Recorded in Document No. 2011081994, O.P.R.W.C., said 0.063 acres being more fully described by metes and bounds in Exhibit “A”, attached hereto and incorporated herein (**Parcel 22**);

together with all and singular the rights and appurtenances pertaining to the property, including any right, title and interest of Seller in and to adjacent streets, alleys or rights-of-way (all of such real property, rights, and appurtenances being referred to in this Contract as the “Property”), and any improvements situated on and attached to the Property described in Exhibits “A” not otherwise agreed herein to be retained by Seller, for the consideration and upon and subject to the terms, provisions, and conditions set forth below.

ARTICLE II
PURCHASE PRICE

Purchase Price

2.01. The Purchase Price for the Property described in Exhibit “A”, any improvements on the Property, and any damage to and/or cost to cure for the remaining property of Seller shall be the sum of SEVEN THOUSAND FOUR HUNDRED SEVENTY and 00/100 Dollars (\$7,470.00).

Payment of Purchase Price

2.02. The Purchase Price shall be payable in cash at the Closing.

**ARTICLE III
PURCHASER'S OBLIGATIONS**

Conditions to Purchaser's Obligations

3.01. The obligations of Purchaser hereunder to consummate the transactions contemplated hereby are subject to the satisfaction of each of the following conditions (any of which may be waived in whole or in part by Purchaser at or prior to the Closing).

Miscellaneous Conditions

3.02. Seller shall have performed, observed, and complied with all of the covenants, agreements, and conditions required by this Contract to be performed, observed, and complied with by Seller prior to or as of the closing.

Title

3.03. Within seven (7) days from the Effective Date of this Contract, Purchaser shall cause the Title Company to furnish to the Purchaser a current commitment ("Title Commitment") for the issuance of an Owner's Policy of Title Insurance together with legible copies of all documents constituting exceptions to Seller's title as reflected in the Title Commitment. Purchaser may, on or prior to five (5) days after its receipt of the later of the Title Commitment, deliver to Seller in writing such reasonable objections as Purchaser may have to anything contained or set forth in the Title Commitment or the title exception documents. In the event Purchaser timely objects to any matter contained in the Title Commitment or title exception documents, Seller shall have a reasonable period of time after receipt of Purchaser's objections within which Seller may attempt to cure such objections specified by Purchaser; provided, however, Seller shall provide reasonable responsive cooperation and assistance requested by Purchaser to cure any objections, but shall be under no obligation to incur any costs whatsoever in connection with such cure. In the event Seller has not yet satisfied each and every of Purchaser's stated title objections within ten (10) days following the date of Purchaser's objections, Purchaser shall elect to either (i) terminate this Contract, or (ii) waive those title objections which Seller has not satisfied and proceed to Closing. In the event Purchaser fails to elect (i) or (ii) in writing within such period, then, and in such event, Purchaser shall be deemed to have elected (ii).

Inspection

Purchaser acknowledges that Seller is providing Purchaser with an opportunity to thoroughly inspect the Property prior to Closing or all purposes, including any concerns with respect to any past, current or future violation of environmental laws or with respect to the presence, either now or in the past, of any hazardous substances at the Property.

ARTICLE IV REPRESENTATIONS AND WARRANTIES OF SELLER

After the Effective Date, Seller agrees that Purchaser shall be entitled to enter upon the Property and to conduct such inspections and audits as Purchaser may reasonably desire.

Seller hereby represents and warrants to Purchaser as follows, which representations and warranties shall be deemed made by Seller to Purchaser also as of the Closing Date, to the best of Seller's current actual knowledge:

(1) Seller has not entered into any lease or other agreement, whether written or oral, granting any other party the right to possess the Property. To Seller's actual knowledge, there are no parties in possession of any portion of the Property as lessees, tenants at sufferance, or trespassers, other than as previously disclosed to Purchaser.

(2) To Seller's actual knowledge, Seller has complied with all applicable laws, ordinances, regulations, statutes, rules and restrictions relating to the Property, or any part thereof.

For purposes of this Contract, wherever the terms "knowledge," "belief," or words of similar import are used with respect to the Seller, such knowledge or belief shall be limited to the actual knowledge of ROBERT S. DYER and BELINDA DYER.

The Property herein is being conveyed to Purchaser under threat of condemnation.

PURCHASER HEREBY EXPRESSLY ACKNOWLEDGES THAT IT HAS OR WILL HAVE, PRIOR TO THE CLOSING, THOROUGHLY INSPECTED AND EXAMINED THE PROPERTY TO THE EXTENT DEEMED NECESSARY BY THE PURCHASER IN ORDER TO ENABLE THE PURCHASER TO EVALUATE THE PURCHASE OF THE PROPERTY. PURCHASER REPRESENTS THAT IT IS A KNOWLEDGEABLE PURCHASER OF ASSETS SUCH AS THE PROPERTY AND THAT IT IS RELYING SOLELY ON ITS OWN EXPERTISE AND THAT OF PURCHASER'S CONSULTANTS, AND THAT PURCHASER WILL CONDUCT SUCH INSPECTIONS AND INVESTIGATIONS OF THE PROPERTY, INCLUDING BUT NOT LIMITED TO THE PHYSICAL AND ENVIRONMENTAL CONDITIONS THEREOF, AND SHALL RELY UPON SAME, AND UPON CLOSING SHALL ASSUME THE RISK OF ANY ADVERSE MATTERS, INCLUDING BUT NOT LIMITED TO,

ADVERSE PHYSICAL AND ENVIRONMENTAL CONDITIONS, THAT MAY NOT HAVE BEEN REVEALED BY PURCHASER'S INSPECTIONS AND INVESTIGATIONS. PURCHASER FURTHER ACKNOWLEDGES AND AGREES THAT PURCHASER IS ACQUIRING THE PROPERTY ON AN AS-IS, WHERE-IS AND WITH ALL FAULTS BASIS WITHOUT REPRESENTATIONS, WARRANTIES OR COVENANTS, EXPRESS OR IMPLIED, OF ANY KIND OR NATURE, EXCEPT THOSE EXPRESSLY INDICATED IN THIS CONTRACT. PURCHASER DISCLAIMS RELIANCE UPON ALL ORAL REPRESENTATIONS AND WARRANTIES, EXPRESS OR IMPLIED, OF ANY KIND OR NATURE, EXCEPT THOSE EXPRESSLY INDICATED IN THIS CONTRACT. PURCHASER HEREBY WAIVES AND RELINQUISHES ALL RIGHTS AND PRIVILEGES ARISING OUT OF, OR WITH RESPECT OR IN RELATION TO, ANY REPRESENTATIONS, WARRANTIES OR COVENANTS, WHETHER EXPRESS OR IMPLIED, WHICH MAY HAVE BEEN MADE OR GIVEN, OR WHICH MAY HAVE BEEN DEEMED TO HAVE BEEN MADE OR GIVEN, BY THE SELLER, EXCEPT THOSE EXPRESSLY INDICATED IN THIS CONTRACT. PURCHASER HEREBY AGREES THAT SELLER SHALL NOT BE LIABLE FOR ANY SPECIAL, DIRECT, INDIRECT, CONSEQUENTIAL OR OTHER DAMAGES RESULTING OR ARISING FROM OR RELATING TO THE OWNERSHIP, USE, CONDITION, LOCATION, MAINTENANCE, REPAIR OR OPERATION OF THE PROPERTY.

SURVIVAL. IT IS AGREED AND UNDERSTOOD THAT THE TERMS AND PROVISIONS OF THIS ARTICLE IV SHALL EXPRESSLY SURVIVE THE CLOSING AND NOT MERGE THEREIN.

ARTICLE V
CLOSING
Closing Date

5.01. The Closing shall be held at the office of Independence Company (the "Title Company") on or before March 1, 2018 or at such time, date, and place as Seller and Purchaser may agree upon, or within 10 days after the completion of any title curative matters if necessary for items as shown on the Title Commitment or in the contract (which date is herein referred to as the "Closing Date").

Seller's Obligations at Closing

5.02. At the Closing Seller shall:

(1) Deliver to Purchaser a duly executed and acknowledged Special Warranty Deed conveying good and indefeasible title to Williamson County, Texas in fee simple to all of the Property described in Exhibit "A", free and clear of any and all liens and restrictions, except for the following:

- (a) General real estate taxes for the year of closing and subsequent years not yet due and payable;
- (b) Any exceptions approved by Purchaser pursuant to Article III hereof; and
- (c) Any exceptions approved by Purchaser in writing.

The Deed shall be in the form as shown in Exhibit "B" attached hereto and incorporated herein.

(2) Cooperate, to the extent required, to ensure that the Title Company will deliver to Purchaser a Texas Owner's Title Policy at Purchaser's sole expense, issued by Title Company, in Grantee's favor in the full amount of the purchase price, insuring Purchaser's contracted interests in and to the Property subject only to those title exceptions listed herein, such other exceptions as may be approved in writing by Purchaser, and the standard printed exceptions contained in the promulgated form of Texas Owner's Title Policy, provided, however:

- (a) The boundary and survey exceptions shall be deleted;
- (b) The exception as to restrictive covenants shall be endorsed "None of Record", if applicable; and
- (c) The exception as to the lien for taxes shall be limited to the year of Closing and shall be endorsed "Not Yet Due and Payable".

(3) Deliver to Purchaser possession of the Property if not previously done.

Purchaser's Obligations at Closing

5.03. At the Closing, Purchaser shall:

- (a) Pay the cash portion of the Purchase Price;
- (b) Pay the costs of Closing as required by this Contract.

Prorations

5.04. General real estate taxes for the then current year relating to the Property shall be prorated as of the Closing Date and shall be adjusted in cash at the closing. If the Closing shall occur before the tax rate is fixed for the then current year, the apportionment of taxes shall be upon the basis of the tax rate for the next preceding year applied to the latest assessed valuation. Agricultural roll-back taxes, if any, shall be paid by Purchaser.

Closing Costs

5.05. All costs and expenses of closing in consummating the sale and purchase of the Property shall be borne and paid as follows:

- (1) Owner's Title Policy (including the base premium and the cost of all endorsements and special elective coverages) and survey to be paid by Purchaser.
- (2) Deed (including recording costs), tax certificates, and title curative matters, if any, paid by Purchaser.
- (3) All other closing costs shall be paid by Purchaser.
- (4) Attorney's fees paid by each respectively.

**ARTICLE VI
BREACH BY SELLER**

In the event Seller shall fail to fully and timely perform any of its obligations hereunder or shall fail to consummate the sale of the Property for any reason, except Purchaser's default, Purchaser may: (1) enforce specific performance of this Contract; or (2) request that the Escrow Deposit, if any, shall be forthwith returned by the title company to Purchaser.

**ARTICLE VII
BREACH BY PURCHASER**

In the event Purchaser should fail to consummate the purchase of the Property, the conditions to Purchaser's obligations set forth in Article III having been satisfied and Purchaser being in default and Seller not being in default hereunder, Seller shall have the right to receive the Escrow Deposit, if any, from the title company, the sum being agreed on as liquidated damages for the failure of Purchaser to perform the duties, liabilities, and obligations imposed upon it by the terms and provisions of this Contract, and Seller agrees to accept and take this cash payment as its total damages and relief and as Seller's sole remedy hereunder in such event. If no Escrow Deposit has been made then Seller shall receive the amount of \$500 as liquidated damages for any failure by Purchaser.

**ARTICLE VIII
MISCELLANEOUS**

Notice

8.01. Any notice required or permitted to be delivered hereunder shall be deemed received when sent by United States mail, postage prepaid, certified mail, return receipt requested, addressed to Seller or Purchaser, as the case may be, at the address set forth opposite the signature of the party.

Texas Law to Apply

8.02. This Contract shall be construed under and in accordance with the laws of the State of Texas, and all obligations of the parties created hereunder are performable in Williamson County, Texas.

Parties Bound; Total Agreement; Modification

8.03. This Contract shall be binding upon and inure to the benefit of the parties and their respective heirs, executors, administrators, legal representatives, successors and assigns where permitted by this Contract. This Contract constitutes the entire agreement among the parties pertaining to the subject matter hereof and supersedes all prior and contemporaneous agreements and understandings of the parties in connection therewith, specifically including any letter of intent negotiated by the parties in relation to the Property. No representation, warranty, covenant, agreement or condition not expressed in this Contract shall be binding upon the parties hereto or shall affect or be effective to interpret, change or restrict the provisions of this Contract. This Contract may not be modified or amended, except by an agreement in writing signed by both the Seller and the Purchaser.

Legal Construction

8.04. In case any one or more of the provisions contained in this Contract shall for any reason be held to be invalid, illegal, or unenforceable in any respect, this invalidity, illegality, or unenforceability shall not affect any other provision hereof, and this Contract shall be construed as if the invalid, illegal, or unenforceable provision had never been contained herein.

Prior Agreements Superseded

8.05. This Contract constitutes the sole and only agreement of the parties and supersedes any prior understandings or written or oral agreements between the parties respecting the within subject matter.

Time of Essence

8.06. Time is of the essence in this Contract.

Gender

8.07. Words of any gender used in this Contract shall be held and construed to include any other gender, and words in the singular number shall be held to include the plural, and vice versa, unless the context requires otherwise.

No Recordation

8.08. Seller and Purchaser hereby acknowledge that neither this Contract nor any memorandum or affidavit thereof shall be recorded of public record in the county where the Property is located or any other county in Texas.

Compliance

8.09. In accordance with the requirements of Section 1101.555 of the Texas Real Estate License Act, **PURCHASER IS HEREBY ADVISED THAT IT SHOULD BE FURNISHED WITH OR OBTAIN A POLICY OF TITLE INSURANCE OR PURCHASER SHOULD HAVE THE ABSTRACT COVERING THE PROPERTY EXAMINED BY AN ATTORNEY OF PURCHASER'S OWN SELECTION.**

Effective Date

8.10. This Contract shall be effective as of the date it is approved by Williamson County, Texas which date is indicated beneath the County Judge's signature below.

Counterparts

8.11. This Contract may be executed in any number of counterparts, which may together constitute the Contract. Signatures transmitted by facsimile or electronic mail may be considered effective as originals for purposes of this Contract.

[signature page follows]

SELLER:

By: 
Daniel Blake Corbell

Address: 300 SARANS LANE
LIBERTY HILL, TX.
78642

By: 
Crystal Fayth Corbell

PURCHASER:

WILLIAMSON COUNTY, TEXAS

By: _____
Dan A. Gattis
County Judge

Address: 710 Main Street, Suite 101
Georgetown, Texas 78626

Date: _____

EXHIBIT __

County: Williamson County
Roadway: CR. 200

PROPERTY DESCRIPTION
PARCEL 22

BEING A 0.063 ACRE (2,749 SQUARE FEET) TRACT OF LAND OUT OF LOT 72, CIERRA VISTA SUBDIVISION, A PLAT RECORDED IN DOCUMENT NO. 2007078025 OF THE OFFICIAL PUBLIC RECORDS OF WILLIAMSON COUNTY, TEXAS (O.P.R.W.C.) AND IN CABINET DD, SLIDE 314 OF THE PLAT RECORDS OF WILLIAMSON COUNTY, TEXAS, SAID LOT 72 BEING CONVEYED TO DANIEL BLAKE CORBELL AND CRYSTAL FAYTH CORBELL, BY DEED RECORDED IN DOCUMENT NO. 2011081994, O.P.R.W.C., SAID 0.063 ACRES, AS SHOWN ON THE ACCOMPANYING SKETCH, BEING MORE PARTICULARLY DESCRIBED BY METES AND BOUNDS AS FOLLOWS:

BEGINNING at a ½" iron rod with plastic cap stamped "SURVTEX" set at the intersection of the proposed west right-of-way (ROW) line of Williamson County Road 200 (C.R. 200) with the north line of Clark Place, a called 50.00' wide R.O.W. recorded on said Cierra Vista plat, same being the south line of said Lot 72 and the southwest corner hereof, from which, a ½" iron rod with cap stamped "3DS" found bears S 68°53'33" W, 282.78' for reference;

1. **THENCE** N 20°29'37" W, across said Lot 72 and with the proposed westerly R.O.W. line of C.R. 200, 137.43' to a ½" iron rod with plastic cap stamped "SURVTEX" set at the intersection of the proposed westerly R.O.W. line of C.R. 200 with a common line being the south line of said Lot 72 and the north line of Lot 71 of said Cierra Vista Subdivision, for the northwest corner hereof;
2. **THENCE** N 68°54'53" E, with said common line, 20.00' to a calculated point in the existing west margin of C.R. 200 (no recording information found), for the common east corner of said Lots 71 and 72, and being the northeast corner hereof, from which ½" iron rod found bears S 68°54'53" W, 0.10' for reference;
3. **THENCE** S 20°29'37" E, with the existing west margin of said C.R. 200, same being the east line of said Lot 72, 137.43' to a ½" iron rod with cap stamped "3DS" found marking the southeast corner of said Lot 72, same being the easterly termination of the north line of said Clark Place, for the southeast corner hereof;

EXHIBIT __

County: Williamson County
Roadway: CR. 200

- 4. **THENCE** S 68°53'33" W, with the north line of Clark Place, same being the south line of said Lot 72, 20.00' to the **POINT OF BEGINNING** and containing 0.063 acres (2,749 square feet) of land, more or less.

The bearings shown hereon are based on: Texas State Plane, Central Zone, NAD 83 (2011). Distances are surface values, scaled using a project Surface Adjustment Factor of 1.00015. (Surface = Plane x 1.00015).

The square footage calculated and shown herein is based on a computed closure of this parcel(s) and is included for informational purposes only.

This property description is accompanied by a separate plat of even date.

THE STATE OF TEXAS §
 § KNOW ALL MEN BY THESE PRESENTS:
 COUNTY OF WILLIAMSON §

That I, Jason E. Parker, a Registered Professional Land Surveyor, do hereby state that the above description is true and correct to the best of my knowledge and belief and that the property described herein was determined by a survey made on the ground under my direction and supervision.

WITNESS MY HAND AND SEAL at Cedar Park, Williamson County, Texas this the 25th day of OCT, 2017, A.D.

SURVTEX LLC
600 W. Whitestone Blvd
Cedar Park, Texas 78613
(512) 249-8875
TBPLS Firm #10084600

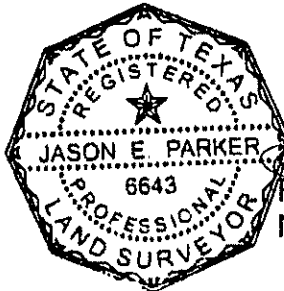

[Handwritten Signature]

 Jason E. Parker
 Registered Professional Land Surveyor
 No. 6643 – State of Texas

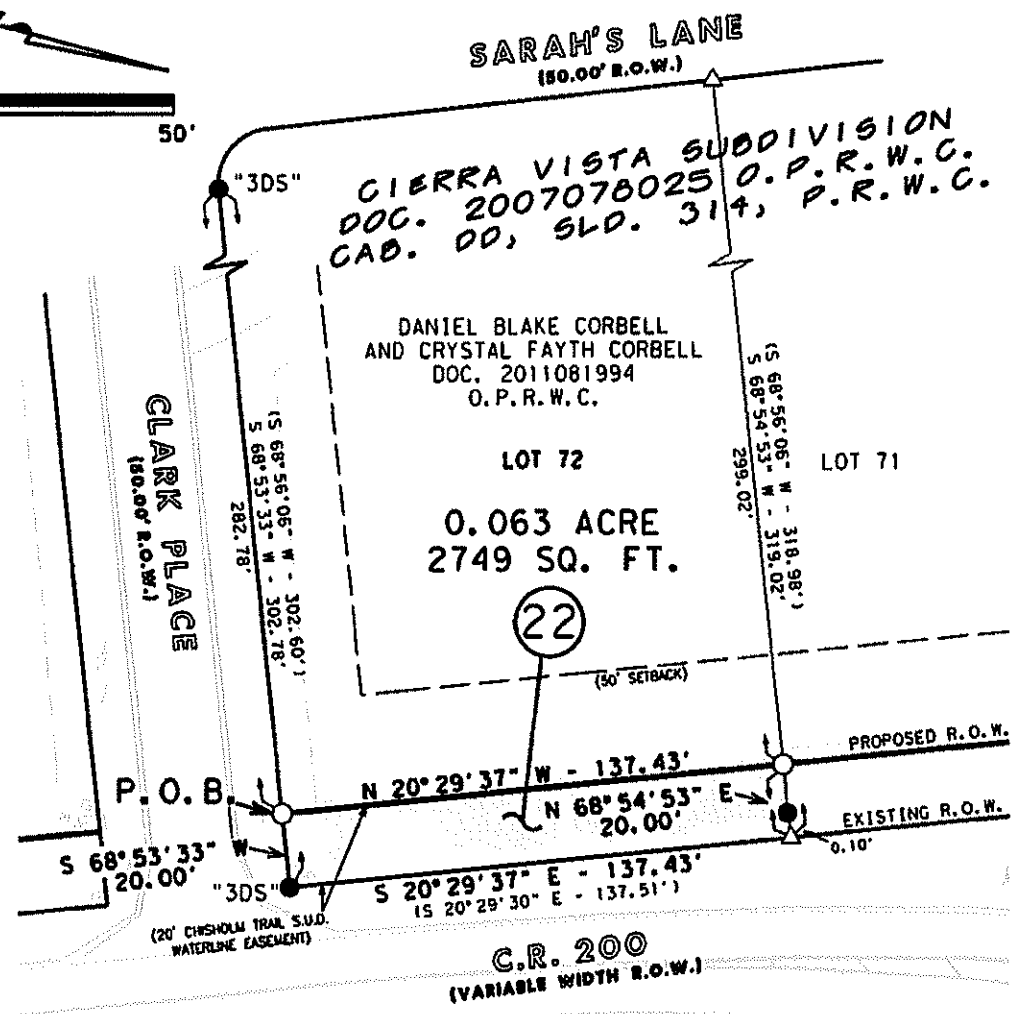
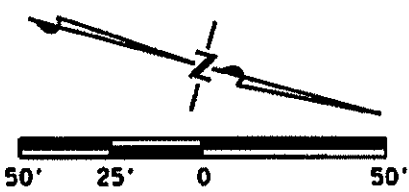

C.R. 200
(VARIABLE WIDTH R.O.W.)

NOTES:

1. THIS SURVEY WAS PERFORMED WITHOUT THE BENEFIT OF A TITLE COMMITMENT. RECORD INFORMATION ON THIS SKETCH IS BASED ON A PUBLIC RECORDS SEARCH BY THE SURVEYOR AND MAY NOT INCLUDE ALL EASEMENTS OR INSTRUMENTS PERTAINING TO THIS PROPERTY.
2. THE BEARINGS SHOWN HEREON ARE: TEXAS STATE PLANE, CENTRAL ZONE, NAD 83 (2011). DISTANCES ARE SURFACE VALUES, SCALED USING A PROJECT SURFACE ADJUSTMENT FACTOR OF 1.00015. (SURFACE = PLANE X 1.00015).
3. IMPROVEMENTS SHOWN ARE FROM ON THE GROUND MAPPING PERFORMED IN 2015.
4. THE SQUARE FOOTAGE CALCULATED AND SHOWN HEREON IS BASED ON A COMPUTED CLOSURE OF THIS PARCEL AND IS FOR INFORMATIONAL PURPOSES ONLY.
5. PROPERTY DESCRIPTION WITH SAME DATE WAS PREPARED WITH THIS PLAT.

I HEREBY CERTIFY THAT THIS SURVEY WAS MADE ON THE GROUND UNDER MY DIRECTION AND SUPERVISION, AND THIS PLAT IS TRUE AND CORRECT TO THE BEST OF MY KNOWLEDGE AND BELIEF.

10.25.17
DATE

JASON E. PARKER
REGISTERED PROFESSIONAL LAND SURVEYOR
No. 6643, STATE OF TEXAS

LEGEND

- (UNLESS OTHERWISE NOTED)
- TxDOT TYPE I MONUMENT FOUND
 - 1/2" IRON ROD SET WITH "SURVTX" CAP
 - 1/2" IRON ROD FOUND
 - △ CALCULATED POINT
 - () RECORD INFORMATION
 - D.R.W.C. DEED RECORDS OF WILLIAMSON COUNTY, TEXAS
 - O.R.W.C. OFFICIAL RECORDS OF WILLIAMSON COUNTY, TEXAS
 - O.P.R.W.C. OFFICIAL PUBLIC RECORDS OF WILLIAMSON COUNTY, TEXAS
 - P.R.W.C. PLAT RECORDS OF WILLIAMSON COUNTY, TEXAS
 - P.O.B. POINT OF BEGINNING
 - P.O.C. POINT OF COMMENCEMENT
 - P.O.R. POINT OF REFERENCE

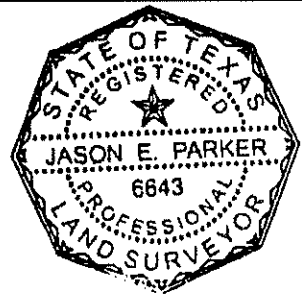

PARCEL 22
ACRES: 0.063
HIGHWAY: C.R. 200
ROW CSJ:
COUNTY: WILLIAMSON
SCALE: 1" = 50'
SHEET 3 OF 3



600 W. WHITESTONE BLVD.
CEDAR PARK, TEXAS 78613
PHONE: (512) 249-8875
FAX (512) 249-5040
TBPLS FIRM NO. 10084600

FILE:P22.dgn

SPECIAL WARRANTY DEED

CR 200 Right of Way

THE STATE OF TEXAS

§

COUNTY OF WILLIAMSON

§

§

NOTICE OF CONFIDENTIALITY RIGHTS: IF YOU ARE A NATURAL PERSON, YOU MAY REMOVE OR STRIKE ANY OF THE FOLLOWING INFORMATION FROM THIS INSTRUMENT BEFORE IT IS FILED IN THE PUBLIC RECORDS: YOUR SOCIAL SECURITY NUMBER OR YOUR DRIVER'S LICENSE NUMBER.

NOW, THEREFORE, KNOW ALL MEN BY THESE PRESENTS:

That DANIEL BLAKE CORBELL and CRYSTAL FAYTH CORBELL, hereinafter referred to as Grantor, whether one or more, for and in consideration of the sum of Ten Dollars (\$10.00) and other good and valuable consideration to Grantor in hand paid by Williamson County, Texas, the receipt and sufficiency of which is hereby acknowledged, and for which no lien is retained, either expressed or implied, have this day Sold and by these presents do Grant, Bargain, Sell and Convey unto WILLIAMSON COUNTY, TEXAS, all that certain tract or parcel of land lying and being situated in the County of Williamson, State of Texas, along with any improvements thereon, being more particularly described as follows:

All of that certain 0.063-acre (2,749 square feet) tract of land out of Lot 72, Cierra Vista Subdivision, a Plat Recorded in Document No. 2007078025 of the Official Public Records of Williamson County, Texas (O.P.R.W.C.) and in Cabinet DD, Slide 314 of the Plat Records of Williamson County, Texas, said Lot 72 being conveyed to Daniel B. Corbell and wife Crystal F. Corbell by Deed Recorded in Document No. 2011081994, O.P.R.W.C., said 0.063 acres being more fully described by metes and bounds in Exhibit "A", attached hereto and incorporated herein (**Parcel 22**);

SAVE AND EXCEPT, HOWEVER, it is expressly understood and agreed that Grantor is retaining title to the following improvements located on the property described in said Exhibit "A" to wit: NONE

RESERVATIONS FROM AND EXCEPTIONS TO CONVEYANCE AND WARRANTY:

Visible and apparent easements not appearing of record;

Any discrepancies, conflicts, or shortages in area or boundary lines or any encroachments or any overlapping of improvements which a current survey would show;

Easements, restrictions, reservations, covenants, conditions, oil and gas leases, mineral severances, and encumbrances for taxes and assessments (other than liens and conveyances)

presently of record in the Official Public Records of Williamson County, Texas, that affect the property, but only to the extent that said items are still valid and in force and effect at this time.

Grantor reserves all of the oil, gas and other minerals in and under the land herein conveyed but waives all rights of ingress and egress to the surface thereof for the purpose of exploring, developing, mining or drilling or pumping the same; provided, however, that operations for exploration or recovery of any such minerals shall be permissible so long as all surface operations in connection therewith are located at a point outside the acquired parcel and upon the condition that none of such operations shall be conducted so near the surface of said land as to interfere with the intended use thereof or in any way interfere with, jeopardize, or endanger the facilities of Williamson County, Texas or create a hazard to the public users thereof; it being intended, however, that nothing in this reservation shall affect the title and the rights of Grantee to take and use without additional compensation any, stone, earth, gravel, caliche, iron ore, gravel or any other road building material upon, in and under said land for the construction and maintenance of CR 200.

TO HAVE AND TO HOLD the property herein described and herein conveyed together with all and singular the rights and appurtenances thereto in any wise belonging unto Williamson County, Texas and its assigns forever; and Grantor does hereby bind itself, its heirs, executors, administrators, successors and assigns to Warrant and Forever Defend all and singular the said premises herein conveyed unto Williamson County, Texas and its assigns against every person whomsoever lawfully claiming or to claim the same or any part thereof, when the claim is by, through, or under Grantor, but not otherwise, except as to the Reservations from and Exceptions to Conveyance and Warranty.

This deed is being delivered in lieu of condemnation.

IN WITNESS WHEREOF, this instrument is executed on this the 14 day of February, 2018.

GRANTOR:

By: 
DANIEL BLAKE CORBELL

By: 
CRYSTAL FAYTH CORBELL

(Acknowledgement Next Page)

ACKNOWLEDGMENTS

STATE OF TEXAS §
COUNTY OF Williamson §
§

This instrument was acknowledged before me on this the 14 day of February, 2018 2018 by DANIEL BLAKE CORBELL, in the capacity and for the purposes and consideration recited therein.

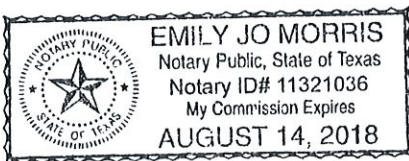

Emily Jo Morris
Notary Public, State of Texas

STATE OF TEXAS §
COUNTY OF Williamson §
§

This instrument was acknowledged before me on this the 14 day of February, 2018 2018 by CYRSTAL FAYTH CORBELL, in the capacity and for the purposes and consideration recited therein.

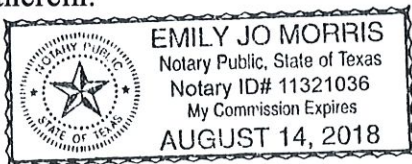

Emily Jo Morris
Notary Public, State of Texas

PREPARED IN THE OFFICE OF:

Sheets & Crossfield, P.C.
309 East Main
Round Rock, Texas 78664

GRANTEE'S MAILING ADDRESS:

Williamson County, Texas
Attn: County Auditor
710 Main Street, Suite 101
Georgetown, Texas 78626

AFTER RECORDING RETURN TO:

Austin Title Company

Seller Pre-Closing/Authorization Information

Seller (1): Daniel BLAINE CORBELL SS #: 403-51-5223

Marital status for seller (1): Married Divorced Single
If Married – Spouse name: Crystal Corbell

Seller (2): Crystal Corbell SS # 632-05-5180

Marital status for seller (2): Married Divorced Single
If Married – Spouse name: Daniel Corbell

CURRENT MAILING ADDRESS: 300 SMARTS Lane Liberty Hill TX 78642

FORWARDING ADDRESS AFTER CLOSING: Same

If sale proceeds will be split at closing, please let us know prior to closing so we may disclose on the settlement statement

Contact information

Seller (1) Cell #: 512 868-7561 Work #: Home #:

E-Mail address: daniel_corbell@yahoo.com

Seller (2) Cell #: 830 385 1887 Work #: Home #:

E-Mail address: Corbell-crystal@yahoo.com

Is there an existing survey? Yes No

If so, have you added or changed anything to the property that would change the survey?

Please note: We will need a signed T-47 with existing survey

Current Mortgage information

1st Lender Name CHASE

Phone 800 848-9136 Account/Loan # 1157289799

2nd Lender Name X

Phone X Account/Loan # X

PLEASE NOTIFY US IMMEDIATELY IF YOU WILL NOT BE ATTENDING CLOSING AND/OR WILL BE USING A POWER OF ATTORNEY, SO WE MAY MAKE ARRANGEMENTS FOR AN OUTSIDE SIGNING AND PREPARE THE POA.

Please sign below authorizing your mortgage company(ies) to release payoff information to Austin Title.

BY: [Signature] BY: Crystal Corbell Date: 2/4/18

Austin Title Company 810 Hesters Crossing #155 Round Rock, TX 78681

Escrow Officer: veronica.harrison@austintitle.com / Escrow Asst: krystal.watts@austintitle.com

Phone: 512-244-2266 / Fax: 512-334-1857

Commissioners Court - Regular Session

37.

Meeting Date: 02/27/2018

CR 200 Contract

Submitted For: Charlie Crossfield

Submitted By: Charlie Crossfield, Road Bond

Department: Road Bond

Agenda Category: Regular Agenda Items

Information

Agenda Item

Discuss, consider and take appropriate action on a real estate contract with Joseph and Holli Pietropaolo for right of way needed on CR 200 (Parcel 18). Funding Source Road Bonds P285

Background

Fiscal Impact

From/To	Acct No.	Description	Amount
---------	----------	-------------	--------

Attachments

[Pietropaolo Contract](#)

Form Review

Inbox

County Judge Exec Asst.

Form Started By: Charlie Crossfield

Final Approval Date: 02/22/2018

Reviewed By

Wendy Coco

Date

02/22/2018 09:58 AM

Started On: 02/22/2018 09:44 AM

REAL ESTATE CONTRACT
CR 200 Right of Way—Parcel 18

THIS REAL ESTATE CONTRACT ("Contract") is made by JOSEPH PIETROPAOLO and HOLLI PIETROPAOLO (referred to collectively in this Contract as "Seller") and WILLIAMSON COUNTY, TEXAS (referred to in this Contract as "Purchaser"), upon the terms and conditions set forth in this Contract.

ARTICLE I
PURCHASE AND SALE

By this Contract, Seller sells and agrees to convey, and Purchaser purchases and agrees to pay for, the tract of land described as follows:

All of that certain 0.064-acre (2,782 square feet) tract of land out of Lot 75, Cierra Vista Subdivision, a Plat Recorded in Document No. 2007078025 of the Official Public Records of Williamson County, Texas (O.P.R.W.C.) and in Cabinet DD, Slide 314 of the Plat Records of Williamson County, Texas, said Lot 75 being conveyed to Joseph Pietropaolo and Holli Pietropaolo, Husband and Wife, with the interest of any deceased co-tenant surviving to the joint owner by Deed Recorded in Document No. 2017015727, O.P.R.W.C., said 0.064 acres being more fully described by metes and bounds in Exhibit "A", attached hereto and incorporated herein (**Parcel 18**);

together with all and singular the rights and appurtenances pertaining to the property, including any right, title and interest of Seller in and to adjacent streets, alleys or rights-of-way (all of such real property, rights, and appurtenances being referred to in this Contract as the "Property"), and any improvements situated on and attached to the Property described in Exhibits "A" not otherwise agreed herein to be retained by Seller, for the consideration and upon and subject to the terms, provisions, and conditions set forth below.

ARTICLE II
PURCHASE PRICE

Purchase Price

2.01. The Purchase Price for the Property described in Exhibit "A", any improvements on the Property, and any damage to and/or cost to cure for the remaining property of Seller shall be the sum of SEVEN THOUSAND TWO HUNDRED FORTY and 00/100 Dollars (\$7,240.00).

By execution of this Contract the parties agree that any improvements or other personal property located within the Property that are to be retained by Seller shall be removed or relocated off of the Property on or before January 31st, 2018, or they shall otherwise become subject to removal or relocation by Purchaser, its contractors or agents after that date.

Payment of Purchase Price

2.02. The Purchase Price shall be payable in cash at the Closing.

ARTICLE III PURCHASER'S OBLIGATIONS

Conditions to Purchaser's Obligations

3.01. The obligations of Purchaser hereunder to consummate the transactions contemplated hereby are subject to the satisfaction of each of the following conditions (any of which may be waived in whole or in part by Purchaser at or prior to the Closing).

Miscellaneous Conditions

3.02. Seller shall have performed, observed, and complied with all of the covenants, agreements, and conditions required by this Contract to be performed, observed, and complied with by Seller prior to or as of the closing.

Title

3.03. Within seven (7) days from the Effective Date of this Contract, Purchaser shall cause the Title Company to furnish to the Purchaser a current commitment ("Title Commitment") for the issuance of an Owner's Policy of Title Insurance together with legible copies of all documents constituting exceptions to Seller's title as reflected in the Title Commitment. Purchaser may, on or prior to five (5) days after its receipt of the later of the Title Commitment, deliver to Seller in writing such reasonable objections as Purchaser may have to anything contained or set forth in the Title Commitment or the title exception documents. In the event Purchaser timely objects to any matter contained in the Title Commitment or title exception documents, Seller shall have a reasonable period of time after receipt of Purchaser's objections within which Seller may attempt to cure such objections specified by Purchaser; provided, however, Seller shall provide reasonable responsive cooperation and assistance requested by Purchaser to cure any objections, but shall be under no obligation to incur any costs whatsoever in connection with such cure. In the event Seller has not yet satisfied each and every of Purchaser's stated title objections within ten (10) days following the date of Purchaser's objections, Purchaser shall elect to either (i) terminate this Contract, or (ii) waive those title objections which Seller has not satisfied and proceed to Closing. In the event Purchaser fails to elect (i) or (ii) in writing within such period, then, and in such event, Purchaser shall be deemed to have elected (ii).

Inspection

Purchaser acknowledges that Seller is providing Purchaser with an opportunity to thoroughly inspect the Property prior to Closing or all purposes, including any concerns with respect to any past, current or future violation of environmental laws or with respect to the presence, either now or in the past, of any hazardous substances at the Property.

**ARTICLE IV
REPRESENTATIONS AND WARRANTIES
OF SELLER**

After the Effective Date, Seller agrees that Purchaser shall be entitled to enter upon the Property and to conduct such inspections and audits as Purchaser may reasonably desire.

Seller hereby represents and warrants to Purchaser as follows, which representations and warranties shall be deemed made by Seller to Purchaser also as of the Closing Date, to the best of Seller's current actual knowledge:

(1) Seller has not entered into any lease or other agreement, whether written or oral, granting any other party the right to possess the Property. To Seller's actual knowledge, there are no parties in possession of any portion of the Property as lessees, tenants at sufferance, or trespassers, other than as previously disclosed to Purchaser.

(2) To Seller's actual knowledge, Seller has complied with all applicable laws, ordinances, regulations, statutes, rules and restrictions relating to the Property, or any part thereof.

For purposes of this Contract, wherever the terms "knowledge," "belief," or words of similar import are used with respect to the Seller, such knowledge or belief shall be limited to the actual knowledge of JOSEPH PIETROPAOLO and HOLLI PIETROPAOLO.

The Property herein is being conveyed to Purchaser under threat of condemnation.

PURCHASER HEREBY EXPRESSLY ACKNOWLEDGES THAT IT HAS OR WILL HAVE, PRIOR TO THE CLOSING, THOROUGHLY INSPECTED AND EXAMINED THE PROPERTY TO THE EXTENT DEEMED NECESSARY BY THE PURCHASER IN ORDER TO ENABLE THE PURCHASER TO EVALUATE THE PURCHASE OF THE PROPERTY. PURCHASER REPRESENTS THAT IT IS A KNOWLEDGEABLE PURCHASER OF ASSETS SUCH AS THE PROPERTY AND THAT IT IS RELYING SOLELY ON ITS OWN EXPERTISE AND THAT OF PURCHASER'S CONSULTANTS, AND THAT PURCHASER WILL CONDUCT SUCH INSPECTIONS AND INVESTIGATIONS OF THE PROPERTY, INCLUDING BUT NOT LIMITED TO THE PHYSICAL AND ENVIRONMENTAL

CONDITIONS THEREOF, AND SHALL RELY UPON SAME, AND UPON CLOSING SHALL ASSUME THE RISK OF ANY ADVERSE MATTERS, INCLUDING BUT NOT LIMITED TO, ADVERSE PHYSICAL AND ENVIRONMENTAL CONDITIONS, THAT MAY NOT HAVE BEEN REVEALED BY PURCHASER'S INSPECTIONS AND INVESTIGATIONS. PURCHASER FURTHER ACKNOWLEDGES AND AGREES THAT PURCHASER IS ACQUIRING THE PROPERTY ON AN AS-IS, WHERE-IS AND WITH ALL FAULTS BASIS WITHOUT REPRESENTATIONS, WARRANTIES OR COVENANTS, EXPRESS OR IMPLIED, OF ANY KIND OR NATURE, EXCEPT THOSE EXPRESSLY INDICATED IN THIS CONTRACT. PURCHASER DISCLAIMS RELIANCE UPON ALL ORAL REPRESENTATIONS AND WARRANTIES, EXPRESS OR IMPLIED, OF ANY KIND OR NATURE, EXCEPT THOSE EXPRESSLY INDICATED IN THIS CONTRACT. PURCHASER HEREBY WAIVES AND RELINQUISHES ALL RIGHTS AND PRIVILEGES ARISING OUT OF, OR WITH RESPECT OR IN RELATION TO, ANY REPRESENTATIONS, WARRANTIES OR COVENANTS, WHETHER EXPRESS OR IMPLIED, WHICH MAY HAVE BEEN MADE OR GIVEN, OR WHICH MAY HAVE BEEN DEEMED TO HAVE BEEN MADE OR GIVEN, BY THE SELLER, EXCEPT THOSE EXPRESSLY INDICATED IN THIS CONTRACT. PURCHASER HEREBY AGREES THAT SELLER SHALL NOT BE LIABLE FOR ANY SPECIAL, DIRECT, INDIRECT, CONSEQUENTIAL OR OTHER DAMAGES RESULTING OR ARISING FROM OR RELATING TO THE OWNERSHIP, USE, CONDITION, LOCATION, MAINTENANCE, REPAIR OR OPERATION OF THE PROPERTY.

SURVIVAL. IT IS AGREED AND UNDERSTOOD THAT THE TERMS AND PROVISIONS OF THIS ARTICLE IV SHALL EXPRESSLY SURVIVE THE CLOSING AND NOT MERGE THEREIN.

ARTICLE V
CLOSING
Closing Date

5.01. The Closing shall be held at the office of Independence Company (the "Title Company") on or before January 31st, 2018 or at such time, date, and place as Seller and Purchaser may agree upon, or within 10 days after the completion of any title curative matters if necessary for items as shown on the Title Commitment or in the contract (which date is herein referred to as the "Closing Date").

Seller's Obligations at Closing

5.02. At the Closing Seller shall:

(1) Deliver to Purchaser a duly executed and acknowledged Special Warranty Deed conveying good and indefeasible title to Williamson County, Texas in fee simple to all of the Property described in Exhibit "A", free and clear of any and all liens and restrictions, except for the following:

- (a) General real estate taxes for the year of closing and subsequent years not yet due and payable;
- (b) Any exceptions approved by Purchaser pursuant to Article III hereof; and
- (c) Any exceptions approved by Purchaser in writing.

The Deed shall be in the form as shown in Exhibit "B" attached hereto and incorporated herein.

(2) Cooperate, to the extent required, to ensure that the Title Company will deliver to Purchaser a Texas Owner's Title Policy at Purchaser's sole expense, issued by Title Company, in Grantee's favor in the full amount of the purchase price, insuring Purchaser's contracted interests in and to the Property subject only to those title exceptions listed herein, such other exceptions as may be approved in writing by Purchaser, and the standard printed exceptions contained in the promulgated form of Texas Owner's Title Policy, provided, however:

- (a) The boundary and survey exceptions shall be deleted;
- (b) The exception as to restrictive covenants shall be endorsed "None of Record", if applicable; and
- (c) The exception as to the lien for taxes shall be limited to the year of Closing and shall be endorsed "Not Yet Due and Payable".

(3) Deliver to Purchaser possession of the Property if not previously done.

Purchaser's Obligations at Closing

5.03. At the Closing, Purchaser shall:

- (a) Pay the cash portion of the Purchase Price;
- (b) Pay the costs of Closing as required by this Contract.

Prorations

5.04. General real estate taxes for the then current year relating to the Property shall be prorated as of the Closing Date and shall be adjusted in cash at the closing. If the Closing shall occur before the tax rate is fixed for the then current year, the apportionment of taxes shall be upon the basis of the tax rate for the next preceding year applied to the latest assessed valuation. Agricultural roll-back taxes, if any, shall be paid by Purchaser.

Closing Costs

5.05. All costs and expenses of closing in consummating the sale and purchase of the Property shall be borne and paid as follows:

- (1) Owner's Title Policy (including the base premium and the cost of all endorsements and special elective coverages) and survey to be paid by Purchaser.
- (2) Deed (including recording costs), tax certificates, and title curative matters, if any, paid by Purchaser.
- (3) All other closing costs shall be paid by Purchaser.
- (4) Attorney's fees paid by each respectively.

**ARTICLE VI
BREACH BY SELLER**

In the event Seller shall fail to fully and timely perform any of its obligations hereunder or shall fail to consummate the sale of the Property for any reason, except Purchaser's default, Purchaser may: (1) enforce specific performance of this Contract; or (2) request that the Escrow Deposit, if any, shall be forthwith returned by the title company to Purchaser.

**ARTICLE VII
BREACH BY PURCHASER**

In the event Purchaser should fail to consummate the purchase of the Property, the conditions to Purchaser's obligations set forth in Article III having been satisfied and Purchaser being in default and Seller not being in default hereunder, Seller shall have the right to receive the Escrow Deposit, if any, from the title company, the sum being agreed on as liquidated damages for the failure of Purchaser to perform the duties, liabilities, and obligations imposed upon it by the terms and provisions of this Contract, and Seller agrees to accept and take this cash payment as its total damages and relief and as Seller's sole remedy hereunder in such event. If no Escrow Deposit has been made then Seller shall receive the amount of \$500 as liquidated damages for any failure by Purchaser.

**ARTICLE VIII
MISCELLANEOUS**

Notice

8.01. Any notice required or permitted to be delivered hereunder shall be deemed received when sent by United States mail, postage prepaid, certified mail, return receipt requested, addressed to Seller or Purchaser, as the case may be, at the address set forth opposite the signature of the party.

Texas Law to Apply

8.02. This Contract shall be construed under and in accordance with the laws of the State of Texas, and all obligations of the parties created hereunder are performable in Williamson County, Texas.

Parties Bound; Total Agreement; Modification

8.03. This Contract shall be binding upon and inure to the benefit of the parties and their respective heirs, executors, administrators, legal representatives, successors and assigns where permitted by this Contract. This Contract constitutes the entire agreement among the parties pertaining to the subject matter hereof and supersedes all prior and contemporaneous agreements and understandings of the parties in connection therewith, specifically including any letter of intent negotiated by the parties in relation to the Property. No representation, warranty, covenant, agreement or condition not expressed in this Contract shall be binding upon the parties hereto or shall affect or be effective to interpret, change or restrict the provisions of this Contract. This Contract may not be modified or amended, except by an agreement in writing signed by both the Seller and the Purchaser.

Legal Construction

8.04. In case any one or more of the provisions contained in this Contract shall for any reason be held to be invalid, illegal, or unenforceable in any respect, this invalidity, illegality, or unenforceability shall not affect any other provision hereof, and this Contract shall be construed as if the invalid, illegal, or unenforceable provision had never been contained herein.

Prior Agreements Superseded

8.05. This Contract constitutes the sole and only agreement of the parties and supersedes any prior understandings or written or oral agreements between the parties respecting the within subject matter.

Time of Essence

8.06. Time is of the essence in this Contract.

Gender

8.07. Words of any gender used in this Contract shall be held and construed to include any other gender, and words in the singular number shall be held to include the plural, and vice versa, unless the context requires otherwise.

No Recordation

8.08. Seller and Purchaser hereby acknowledge that neither this Contract nor any memorandum or affidavit thereof shall be recorded of public record in the county where the Property is located or any other county in Texas.

Compliance

8.09. In accordance with the requirements of Section 1101.555 of the Texas Real Estate License Act, **PURCHASER IS HEREBY ADVISED THAT IT SHOULD BE FURNISHED WITH OR OBTAIN A POLICY OF TITLE INSURANCE OR PURCHASER SHOULD HAVE THE ABSTRACT COVERING THE PROPERTY EXAMINED BY AN ATTORNEY OF PURCHASER'S OWN SELECTION.**

Effective Date

8.10. This Contract shall be effective as of the date it is approved by Williamson County, Texas which date is indicated beneath the County Judge's signature below.

Counterparts

8.11. This Contract may be executed in any number of counterparts, which may together constitute the Contract. Signatures transmitted by facsimile or electronic mail may be considered effective as originals for purposes of this Contract.

Exhibits

8.12. The following Exhibits are attached hereto:

- Exhibit "A": Property metes and bounds legal description
- Exhibit "B": Agreed Deed Form

[signature page follows]

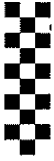

SELLER:

By: 
JOSEPH PIETROPAOLO

By: 
HOLLI PIETROPAOLO

Address: 224 SARAH'S LANE
LIBERTY HILL TX
78642

PURCHASER:

WILLIAMSON COUNTY, TEXAS

By: _____
Dan A. Gattis
County Judge

Address: 710 Main Street, Suite 101
Georgetown, Texas 78626

Date: _____

County: Williamson County
 Roadway: CR. 200



**PROPERTY DESCRIPTION
 PARCEL 18**

BEING A 0.064 ACRE (2782 SQUARE FEET) TRACT OF LAND OUT OF LOT 75, CIERRA VISTA SUBDIVISION, A PLAT RECORDED IN DOCUMENT NO. 2007078025 OF THE OFFICIAL PUBLIC RECORDS OF WILLIAMSON COUNTY, TEXAS (O.P.R.W.C.) AND IN CABINET DD, SLIDE 314 OF THE PLAT RECORDS OF WILLIAMSON COUNTY, TEXAS, SAID LOT 75 BEING CONVEYED TO JOSEPH PIETROPAOLO AND HOLLI PIETROPAOLO, HUSBAND AND WIFE, WITH THE INTEREST OF ANY DECEASED CO-TENANT SURVIVING TO THE JOINT OWNER, BY DEED RECORDED IN DOCUMENT NO. 2017015727, O.P.R.W.C., SAID 0.064 ACRES, AS SHOWN ON THE ACCOMPANYING SKETCH, BEING MORE PARTICULARLY DESCRIBED BY METES AND BOUNDS AS FOLLOWS:

BEGINNING at a ½" iron rod with plastic cap stamped "SURVTEX" set at the intersection of the proposed westerly right-of-way (R.O.W.) line of Williamson County Road 200 (C.R. 200) with the south line of said Lot 75, same being the north line of Lot 76 of said Cierra Vista Subdivision, and being the southwest corner hereof, from which an ½" iron rod with cap stamped "3DS" found marking the common west corner of said Lots 75 and 76 bears S 68°59'19" W, 294.08' for reference;

1. **THENCE** N 21°03'28" W, crossing into said Lot 75 and with the proposed westerly R.O.W. line of C.R. 200, 106.55' to a ½" iron rod with plastic cap stamped "SURVTEX" set marking an angle point in the proposed westerly R.O.W. line of C.R. 200, for an angle point in the west line hereof;
2. **THENCE** N 20°29'37" W, continuing across said Lot 75 and with the proposed westerly R.O.W. line of C.R. 200, 32.55' to a ½" iron rod with plastic cap stamped "SURVTEX" set at the intersection of the proposed westerly R.O.W. line of C.R. 200 with a common line being the north line of said Lot 75 and the south line of Lot 74 of said Cierra Vista Subdivision, for the northwest corner hereof;
3. **THENCE** N 68°55'53" E, with said common line, 20.00' to a ½" iron rod found in the existing west margin of C.R. 200 (no recording information found), same being the common east corner of said Lots 74 and 75, for the north east corner hereof,
4. **THENCE** S 20°29'37" E, with the existing west margin of said C.R. 200, same being the east line of said Lot 75, 32.65' to a ½" iron rod with cap stamped "HALLENBERGER" found marking an angle point in the existing west margin of C.R. 200, same being an angle point in the east line of said Lot 75 and hereof;

EXHIBIT ___

County: Williamson County
Roadway: CR. 200

- 5. THENCE S 21°03'28" E, continuing with the existing west margin of said C.R. 200, same being the east line of said Lot 75, 106.47' to a calculated point for the common east corner of said Lots 75 and 76 for the southeast corner hereof, from which a 1/2" iron rod found bears N 68°59'19" E, 0.13' for reference;
- 6. THENCE S 68°59'19" W, with the south line of said Lot 75, same being the north line of said Lot 76, 20.00' to the **POINT OF BEGINNING** and containing 0.064 acres (2,782 square feet) of land, more or less.

The bearings shown hereon are based on: Texas State Plane, Central Zone, NAD 83 (2011). Distances are surface values, scaled using a project Surface Adjustment Factor of 1.00015. (Surface = Plane x 1.00015).

The square footage calculated and shown herein is based on a computed closure of this parcel(s) and is included for informational purposes only.

This property description is accompanied by a separate plat of even date.

THE STATE OF TEXAS §
 § KNOW ALL MEN BY THESE PRESENTS:
COUNTY OF WILLIAMSON §

That I, Jason E. Parker, a Registered Professional Land Surveyor, do hereby state that the above description is true and correct to the best of my knowledge and belief and that the property described herein was determined by a survey made on the ground under my direction and supervision.

WITNESS MY HAND AND SEAL at Cedar Park, Williamson County, Texas this the 25th day of oct, 2017, A.D.

SURVTEX LLC
600 W. Whitestone Blvd
Cedar Park, Texas 78613
(512) 249-8875
TBPLS Firm #10084600

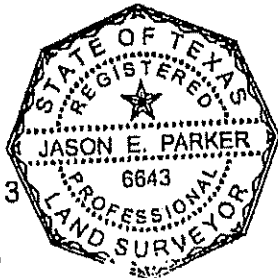



Jason E. Parker
Registered Professional Land Surveyor
No. 6643 – State of Texas

SARAH'S LANE
(80.00' R.O.W.)

"3DS"

CIERRA VISTA SUBDIVISION
DOC. 2007078025 O.P.R.W.C.
CAB. 00, SLD. 314, P.R.W.C.

JOSEPH PIETROPAOLO
AND HOLLY PIETROPAOLO,
HUSBAND AND WIFE,
WITH THE INTEREST OF ANY
DECEASED CO-TENANT SURVIVING
TO THE JOINT OWNER
DOC. 20100477921
O.P.R.W.C.

LOT 76

LOT 75

0.064 ACRE
18 2782 SQ. FT.

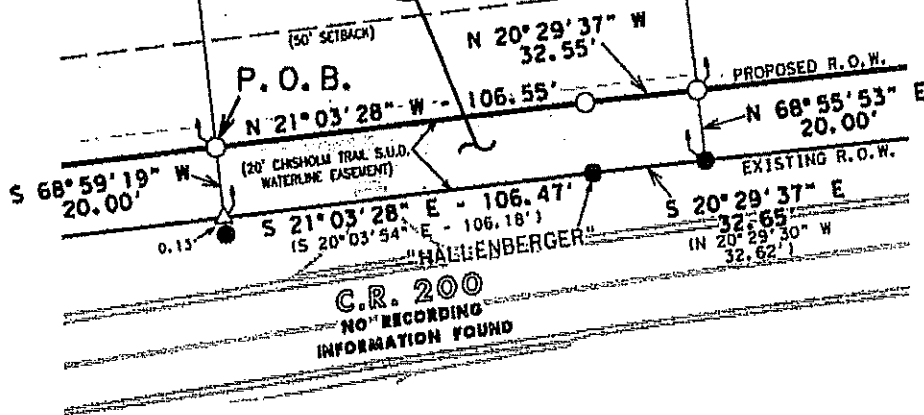

NOTES:

1. THIS SURVEY WAS PERFORMED WITHOUT THE BENEFIT OF A TITLE COMMITMENT. RECORD INFORMATION ON THIS SKETCH IS BASED ON A PUBLIC RECORDS SEARCH BY THE SURVEYOR AND MAY NOT INCLUDE ALL EASEMENTS OR INSTRUMENTS PERTAINING TO THIS PROPERTY.
2. THE BEARINGS SHOWN HEREON ARE: TEXAS STATE PLANE, CENTRAL ZONE, NAD 83 (2011). DISTANCES ARE SURFACE VALUES, SCALED USING A PROJECT SURFACE ADJUSTMENT FACTOR OF 1.00015. (SURFACE = PLANE X 1.00015).
3. IMPROVEMENTS SHOWN ARE FROM ON THE GROUND MAPPING PERFORMED IN 2015.
4. THE SQUARE FOOTAGE CALCULATED AND SHOWN HEREON IS BASED ON A COMPUTED CLOSURE OF THIS PARCEL AND IS FOR INFORMATIONAL PURPOSES ONLY.
5. PROPERTY DESCRIPTION WITH SAME DATE WAS PREPARED WITH THIS PLAT.

I HEREBY CERTIFY THAT THIS SURVEY WAS MADE ON THE GROUND UNDER MY DIRECTION AND SUPERVISION, AND THIS PLAT IS TRUE AND CORRECT TO THE BEST OF MY KNOWLEDGE AND BELIEF.

10-25-17
DATE

JASON E. PARKER
REGISTERED PROFESSIONAL LAND SURVEYOR
NO. 6643, STATE OF TEXAS



600 W. WHITESTONE BLVD.
CEDAR PARK, TEXAS 78613
PHONE: (512) 249-8875
FAX (512) 249-5040
TBPLS FIRM NO. 10084600



PARCEL 18
ACRES: 0.064
HIGHWAY: C.R. 200
ROW CSJ:
COUNTY: WILLIAMSON
SCALE: 1" = 50'
SHEET 3 OF 3

FILE: P18.dgn

LEGEND

- (UNLESS OTHERWISE NOTED)
- TxDOT TYPE I MONUMENT FOUND
 - 1/2" IRON ROD SET WITH "SURVITEX" CAP
 - 1/2" IRON ROD FOUND
 - △ CALCULATED POINT
 - () RECORD INFORMATION
 - D.R.W.C. DEED RECORDS OF WILLIAMSON COUNTY, TEXAS
 - O.R.W.C. OFFICIAL RECORDS OF WILLIAMSON COUNTY, TEXAS
 - O.P.R.W.C. OFFICIAL PUBLIC RECORDS OF WILLIAMSON COUNTY, TEXAS
 - P.R.W.C. PLAY RECORDS OF WILLIAMSON COUNTY, TEXAS
 - P.O.B. POINT OF BEGINNING
 - P.O.C. POINT OF COMMENCEMENT
 - P.O.R. POINT OF REFERENCE

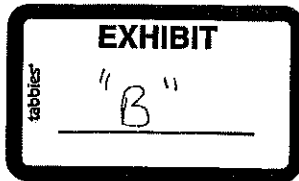

Parcel 18

SPECIAL WARRANTY DEED
CR 200 Right of Way

THE STATE OF TEXAS

§
§
§

COUNTY OF WILLIAMSON

NOTICE OF CONFIDENTIALITY RIGHTS: IF YOU ARE A NATURAL PERSON, YOU MAY REMOVE OR STRIKE ANY OF THE FOLLOWING INFORMATION FROM THIS INSTRUMENT BEFORE IT IS FILED IN THE PUBLIC RECORDS: YOUR SOCIAL SECURITY NUMBER OR YOUR DRIVER'S LICENSE NUMBER.

NOW, THEREFORE, KNOW ALL MEN BY THESE PRESENTS:

That JOSEPH PIETROPAOLO and HOLLY PIETROPAOLO, hereinafter referred to as Grantor, whether one or more, for and in consideration of the sum of Ten Dollars (\$10.00) and other good and valuable consideration to Grantor in hand paid by Williamson County, Texas, the receipt and sufficiency of which is hereby acknowledged, and for which no lien is retained, either expressed or implied, have this day Sold and by these presents do Grant, Bargain, Sell and Convey unto WILLIAMSON COUNTY, Texas, all that certain lot or parcel of land lying and being situated in the County of Williamson, State of Texas, along with any improvements thereon, being more particularly described as follows:

All of that certain 0.062 (2,782 square feet) tract of land out of Lot 75, Cierra Vista Subdivision, a Plat Recorded in Document No. 2007078025 of the Official Public Records of Williamson County, Texas (O.P.R. W.C.) and in Cabinet DD, Slide 314 of the Plat Records of Williamson County, Texas, and Lot 75 being conveyed to Joseph Pietropaolo and Holly Pietropaolo, husband and wife, with the interest of any deceased co-tenants owing to the grant owner by deed Recorded in Document No. 2017015727, O.P.R. W.C., said 0.064 acre being more fully described by metes and bounds in Exhibit "A", attached hereto and incorporated herein.

SAVE AND EXCEPT, HOWEVER, it is expressly understood and agreed that Grantor is retaining title in the following improvements located on the property described in said Exhibit "A" to wit: NONE

RESERVATIONS FROM AND EXCEPTIONS TO CONVEYANCE AND WARRANTY:

Visible and apparent easements not appearing of record;

Any discrepancies, conflicts, or shortages in area or boundary lines or any encroachments or any overlapping of improvements which a current survey would show;

Easements, restrictions, reservations, covenants, conditions, oil and gas leases, mineral severances, and encumbrances for taxes and assessments (other than liens and conveyances)

presently of record in the Official Public Records of Williamson County, Texas, that affect the property, but only to the extent that said items are still valid and in force and effect at this time.

Grantor reserves all of the oil, gas and other minerals in and under the land herein conveyed but waives all rights of ingress and egress to the surface thereof for the purpose of exploring, developing, mining or drilling or pumping the same; provided, however, that operations for exploration or recovery of any such minerals shall be permissible so long as all surface operations in connection therewith are located at a point outside the acquired parcel and upon the condition that none of such operations shall be conducted so near the surface of said land as to interfere with the intended use thereof or in any way interfere with, jeopardize, or endanger the facilities of Williamson County, Texas or create a hazard to the public users thereof; it being intended, however, that nothing in this reservation shall affect the title and the rights of Grantee to take and use without additional compensation any, stone, earth, gravel, caliche, iron ore, gravel or any other road building material upon, in and under said land for the construction and maintenance of CR 200.

TO HAVE AND TO HOLD the property herein described and herein conveyed together with all and singular the rights and appurtenances thereto in anywise belonging unto Williamson County, Texas and its assigns forever; and Grantor does hereby bind itself, its heirs, executors, administrators, successors and assigns to Warrant and Foreclose Defend all and singular the said premises herein conveyed unto Williamson County, Texas and its assigns against every person whomsoever lawfully claiming or to claim the same or any part thereof, when the claim is by, through, or under Grantor, but not otherwise, except as to the Reservations from and Exceptions to Conveyance and Warranty.

This deed is being delivered in lieu of condemnation.

IN WITNESS WHEREOF, this instrument is executed on this the ____ day of _____, 2018.

GRANTOR:

By: _____
JOSEPH PIETROPALO

By: _____
HOLLI PIETROPALO

(Acknowledgement Next Page)

EXHIBIT A

County: Williamson County
 Roadway: CR. 200

PROPERTY DESCRIPTION
 PARCEL 18

BEING A 0.064 ACRE (2782 SQUARE FEET) TRACT OF LAND OUT OF LOT 75, CIERRA VISTA SUBDIVISION, A PLAT RECORDED IN DOCUMENT NO. 2007078025 OF THE OFFICIAL PUBLIC RECORDS OF WILLIAMSON COUNTY, TEXAS (O.P.R.W.C.) AND IN CABINET DD, SLIDE 314 OF THE PLAT RECORDS OF WILLIAMSON COUNTY, TEXAS, SAID LOT 75 BEING CONVEYED TO JOSEPH PIETROPAOLO AND HOLLI PIETROPAOLO, HUSBAND AND WIFE, WITH THE INTEREST OF ANY DECEASED CO-TENANT SURVIVING TO THE JOINT OWNER, BY DEED RECORDED IN DOCUMENT NO. 2017015727, O.P.R.W.C., SAID 0.064 ACRES, AS SHOWN ON THE ACCOMPANYING SKETCH, BEING MORE PARTICULARLY DESCRIBED BY METES AND BOUNDS AS FOLLOWS:

BEGINNING at a ½" iron rod with plastic cap stamped "SURVTEX" set at the intersection of the proposed westerly right-of-way (R.O.W.) line of Williamson County Road 200 (C.R. 200) with the south line of said Lot 75, same being the north line of Lot 76 of said Cierra Vista Subdivision, and being the southwest corner hereof, from which an ½" iron rod with cap stamped "3DS" found marking the common west corner of said Lots 75 and 76 bears S 68°59'19" W, 294.08' for reference;

1. **THENCE** N 21°03'28" W, crossing into said Lot 75 and with the proposed westerly R.O.W. line of C.R. 200, 106.55' to a ½" iron rod with plastic cap stamped "SURVTEX" set marking an angle point in the proposed westerly R.O.W. line of C.R. 200, for an angle point in the west line hereof;
2. **THENCE** N 20°29'37" W, continuing across said Lot 75 and with the proposed westerly R.O.W. line of C.R. 200, 32.55' to a ½" iron rod with plastic cap stamped "SURVTEX" set at the intersection of the proposed westerly R.O.W. line of C.R. 200 with a common line being the north line of said Lot 75 and the south line of Lot 74 of said Cierra Vista Subdivision, for the northwest corner hereof;
3. **THENCE** N 68°55'53" E, with said common line, 20.00' to a ½" iron rod found in the existing west margin of C.R. 200 (no recording information found), same being the common east corner of said Lots 74 and 75, for the north east corner hereof,
4. **THENCE** S 20°29'37" E, with the existing west margin of said C.R. 200, same being the east line of said Lot 75, 32.65' to a ½" iron rod with cap stamped "HALLENBERGER" found marking an angle point in the existing west margin of C.R. 200, same being an angle point in the east line of said Lot 75 and hereof;

EXHIBIT "A"

County: Williamson County
Roadway: CR. 200

- 5. THENCE S 21°03'28" E, continuing with the existing west margin of said C.R. 200, same being the east line of said Lot 75, 106.47' to a calculated point for the common east corner of said Lots 75 and 76 for the southeast corner hereof, from which a 1/2" iron rod found bears N 68°59'19" E, 0.13' for reference;
- 6. THENCE S 68°59'19" W, with the south line of said Lot 75, same being the north line of said Lot 76, 20.00' to the **POINT OF BEGINNING** and containing 0.064 acres (2,782 square feet) of land, more or less.

The bearings shown hereon are based on: Texas State Plane, Central Zone, NAD 83 (2011). Distances are surface values, scaled using a project Surface Adjustment Factor of 1.00015. (Surface = Plane x 1.00015).

The square footage calculated and shown herein is based on a computed closure of this parcel(s) and is included for informational purposes only.

This property description is accompanied by a separate plat of even date.

THE STATE OF TEXAS §
 § KNOW ALL MEN BY THESE PRESENTS:
COUNTY OF WILLIAMSON §

That I, Jason E. Parker, a Registered Professional Land Surveyor, do hereby state that the above description is true and correct to the best of my knowledge and belief and that the property described herein was determined by a survey made on the ground under my direction and supervision.

WITNESS MY HAND AND SEAL at Cedar Park, Williamson County, Texas this the 25th day of oct, 2017, A.D.

SURVTEX LLC
600 W. Whitestone Blvd
Cedar Park, Texas 78613
(512) 249-8875
TBPLS Firm #10084600

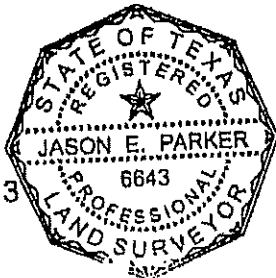



Jason E. Parker
Registered Professional Land Surveyor
No. 6643 – State of Texas

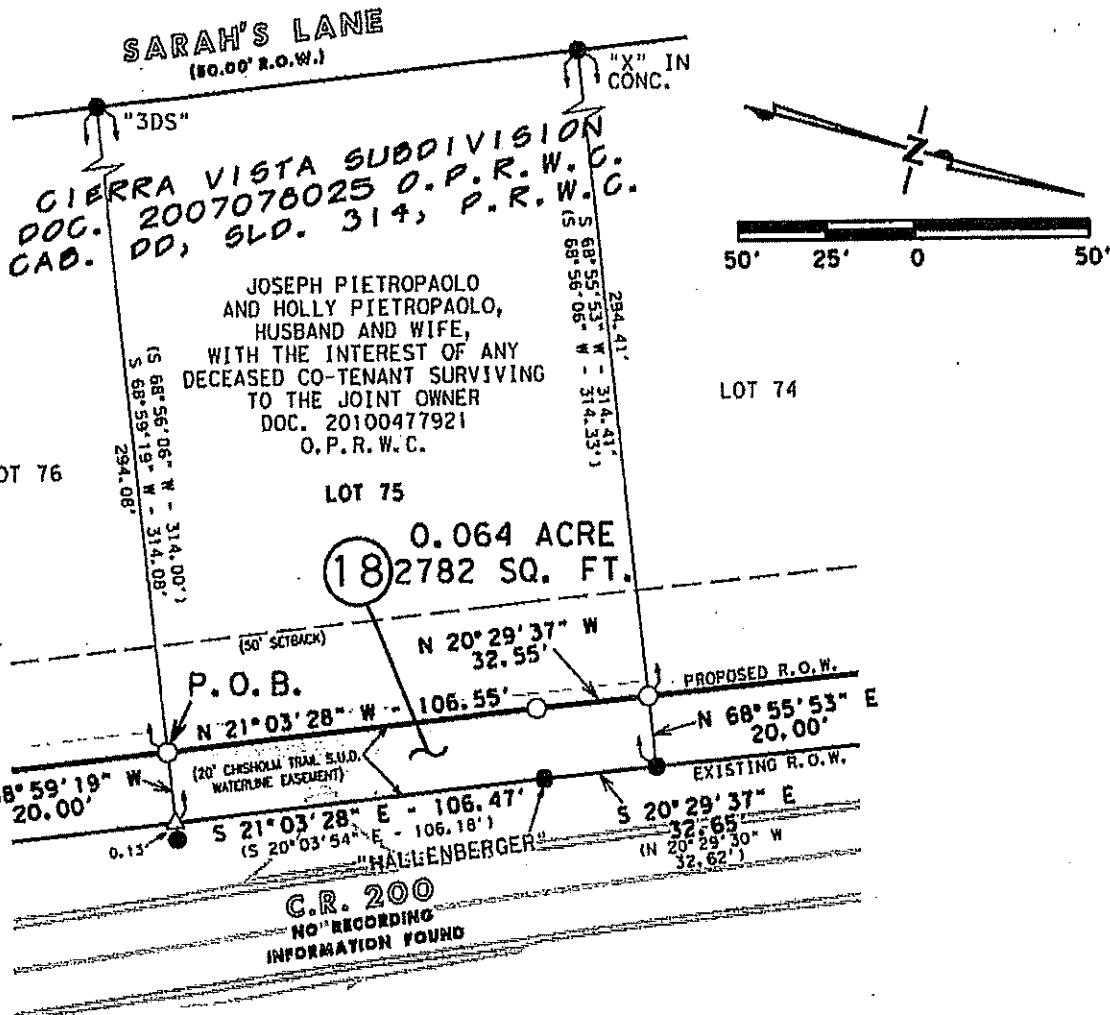

CIERRA VISTA SUBDIVISION
 DOC. 2007078025 O.P.R.W.C.
 CAD. DD, SLD. 314, P.R.W.C.

JOSEPH PIETROPAOLO
 AND HOLLY PIETROPAOLO,
 HUSBAND AND WIFE,
 WITH THE INTEREST OF ANY
 DECEASED CO-TENANT SURVIVING
 TO THE JOINT OWNER
 DOC. 20100477921
 O.P.R.W.C.

LOT 74
LOT 75
LOT 76

0.064 ACRE
 18,2782 SQ. FT.

P.O.B.
 (50' SETBACK)
 N 20° 29' 37" W 32.55'
 N 21° 03' 28" W 106.55'
 N 68° 55' 53" E 20.00'
 PROPOSED R.O.W.

(20' CHESHOLM TRAIL S.U.D. WATERLINE EASEMENT)
 S 68° 59' 19" W 20.00'
 S 21° 03' 28" E 106.47'
 S 20° 03' 54" E 106.18'
 EXISTING R.O.W.

"HALLENBERGER"
 C.R. 200
 NO RECORDING INFORMATION FOUND

NOTES:

1. THIS SURVEY WAS PERFORMED WITHOUT THE BENEFIT OF A TITLE COMMITMENT, RECORD INFORMATION ON THIS SKETCH IS BASED ON A PUBLIC RECORDS SEARCH BY THE SURVEYOR AND MAY NOT INCLUDE ALL EASEMENTS OR INSTRUMENTS PERTAINING TO THIS PROPERTY.
2. THE BEARINGS SHOWN HEREON ARE: TEXAS STATE PLANE, CENTRAL ZONE, NAD 83 (2011). DISTANCES ARE SURFACE VALUES, SCALED USING A PROJECT SURFACE ADJUSTMENT FACTOR OF 1.00015. (SURFACE = PLANE X 1.00015).
3. IMPROVEMENTS SHOWN ARE FROM ON THE GROUND MAPPING PERFORMED IN 2015.
4. THE SQUARE FOOTAGE CALCULATED AND SHOWN HEREON IS BASED ON A COMPUTED CLOSURE OF THIS PARCEL AND IS FOR INFORMATIONAL PURPOSES ONLY.
5. PROPERTY DESCRIPTION WITH SAME DATE WAS PREPARED WITH THIS PLAT.

I HEREBY CERTIFY THAT THIS SURVEY WAS MADE ON THE GROUND UNDER MY DIRECTION AND SUPERVISION, AND THIS PLAT IS TRUE AND CORRECT TO THE BEST OF MY KNOWLEDGE AND BELIEF.

10-25-17
 DATE

JASON E. PARKER
 REGISTERED PROFESSIONAL LAND SURVEYOR
 NO. 6843, STATE OF TEXAS

LEGEND

- (UNLESS OTHERWISE NOTED)
- TxDOT TYPE I MONUMENT FOUND
 - 1/2" IRON ROD SET WITH "SURVTEX" CAP
 - 1/2" IRON ROD FOUND
 - △ CALCULATED POINT
 - () RECORD INFORMATION
 - D.R.W.C. DEED RECORDS OF WILLIAMSON COUNTY, TEXAS
 - O.R.W.C. OFFICIAL RECORDS OF WILLIAMSON COUNTY, TEXAS
 - O.P.R.W.C. OFFICIAL PUBLIC RECORDS OF WILLIAMSON COUNTY, TEXAS
 - P.R.W.C. PLAT RECORDS OF WILLIAMSON COUNTY, TEXAS
 - P.O.B. POINT OF BEGINNING
 - P.O.C. POINT OF COMMENCEMENT
 - P.O.R. POINT OF REFERENCE



PARCEL 18
 ACRES: 0.064
 HIGHWAY: C.R. 200
 ROW CSJ:
 COUNTY: WILLIAMSON
 SCALE: 1" = 50'
 SHEET 3 OF 3

FILE: P18.dgn



600 W. WHITESTONE BLVD,
 CEDAR PARK, TEXAS 78613
 PHONE: (512) 249-8875
 FAX (512) 249-5040
 TBPLS FIRM NO. 10084600

Commissioners Court - Regular Session

38.

Meeting Date: 02/27/2018

N. Mays Escrow Agreement

Submitted For: Charlie Crossfield

Submitted By: Charlie Crossfield, Road Bond

Department: Road Bond

Agenda Category: Regular Agenda Items

Information

Agenda Item

Discuss, consider and take appropriate action on an escrow agreement with Chandler Creek LP regarding work to be done by the County as a part of the construction of the N. Mays project. (Parcel 7). Funding Source: General Funds

Background

Fiscal Impact

From/To	Acct No.	Description	Amount
---------	----------	-------------	--------

Attachments

Escrow Agreement

Form Review

Inbox

County Judge Exec Asst.

Form Started By: Charlie Crossfield

Final Approval Date: 02/22/2018

Reviewed By

Wendy Coco

Date

02/22/2018 09:58 AM

Started On: 02/22/2018 09:45 AM

ESCROW AGREEMENT

This Escrow Agreement (“Agreement”) is made and entered into by and among CHANDLER CREEK, L.P., a Delaware limited partnership (“Seller”), WILLIAMSON COUNTY, TEXAS, (“Purchaser”) and INDEPENDENCE TITLE COMPANY, (“Escrow Agent”). Seller and Purchaser are sometimes herein referred to collectively as the “Contract Parties”.

1. Escrow Provisions.

A. Seller and Purchaser are parties to that certain “Real Estate Contract” dated January 23, 2018 (the “Contract”) pursuant to which Seller has agreed to sell to Purchaser and Purchaser has agreed to purchase from Seller, the real property described on Exhibit “A” attached hereto and incorporated herein by referenced (the “Property”).

B. Pursuant to the terms and provisions of the Contract and concurrently with the execution of this Agreement: (i) Seller has executed and delivered to Escrow Agent that certain “Deed”, a copy of which is attached to this Agreement as Exhibit “B” and is incorporated herein by reference (the “Deed”); and (ii) Purchaser has delivered to Escrow Agent the sum of Five Hundred Thousand and No/100 Dollars (\$500,000.00) in readily available funds (the “Deposit”).

C. The Contract Parties hereby agree as follows and instruct the Escrow Agent as follows with respect to the Deed: (i) if all conditions to the closing under the Contract are satisfied, Seller will provide to the Escrow Agent Seller’s written authorization to release and record the Deed; or (ii) if Seller delivers to Purchaser and the Escrow Agent a written notice that the Contract has been terminated for any reason, then Escrow Agent shall immediately deliver the Deed to Seller.

D. The Contract Parties hereby agree as follows and instruct the Escrow Agent as follows with respect to the Deposit: (i) the Deposit must be placed in an interest bearing account approved by the Contract Parties and all accrued interest will be added to and become a portion of the Deposit; (ii) Purchaser will have the right to draw upon the Deposit with Seller’s written approval, which will not be unreasonably withheld so long as Purchaser provides evidence reasonably acceptable to Seller that the remainder of the “Work” (as that term is defined in the Contract, and herein so called) can be completed at a total expense of \$400,000.00 or less and so long as at least \$100,000.00 is retained in the Deposit until the closing under the Contract; (iii) with each request for a disbursement from the Deposit, Purchaser will provide to Escrow Agent and to Seller: (1) written confirmation from Purchaser’s engineer that (a) the remainder of the Work can be completed for a total expense that is a least \$100,000.00 less than the amount that will remain in the Deposit after the requested disbursement is made, (b) all of the Work has been conducted in accordance with the “Final Plans” (as defined in the Contract and herein so called) and in compliance with all applicable laws, (2) copies of invoices or other evidence of payment sufficient to establish the expenditures incurred by Purchaser, (3) conditional lien waivers for the invoices to be paid out of the current disbursement from the

Deposit; (iv) unconditional lien waivers for all previously completed portions of the Work shall be provided prior to final release of any remaining portion of the retained Deposit at closing under the Contract; and (v) Seller will have the right to draw upon the Deposit in the event of a default by Purchaser under the Contract, and which funds shall be expended by Seller for completion of the Work, with any excess upon final completion to be returned to Purchaser.

2. Appointment of Escrow Agent. The Contract Parties hereby appoint and designate Independence Title Company as Escrow Agent.

3. Acceptance of Appointment. Escrow Agent agrees to serve hereunder for the purposes and on the terms hereinafter set forth.

4. Scope of Undertaking. Escrow Agent's duties and responsibilities are limited to those expressly set forth in this Agreement. Escrow Agent has no responsibility or obligation of any kind in connection with this Agreement and the Assignment, other than to receive, hold and deliver the Assignment as herein provided.

5. Knowledge and Sufficiency of Documents. Escrow Agent will not be charged with notice or knowledge of any fact or information not herein set out. Escrow Agent will not be required in any way to determine the validity, sufficiency, accuracy or genuineness, whether in form or in substance, of the Assignment or of any instrument, document, certificate, statement or notice referred to in this Agreement or contemplated hereby. It will be sufficient if any writing purporting to be such instrument, document, certificate, statement or notice is delivered to Escrow Agent and purports on its face to be correct in form and signed or otherwise executed by the party or parties required to sign or execute the same under this Agreement. Escrow Agent will not be required in any way to determine the identity or authority of any person executing the same or the genuineness of any such signature.

6. Conflicts; Force Majeure. In the event of any disagreement or conflicting instructions resulting in adverse claims or demands being made upon Escrow Agent in connection herewith, or in the event that Escrow Agent, in good faith, is in doubt as to what action should be taken hereunder, it may, at its option, refuse to comply with any claims or demands on it, or refuse to take any other action hereunder, so long as such disagreement continues or such doubt exists, and in any such event, Escrow Agent shall not be or become liable in any way or to any party for its failure or refusal to act until all differences shall have been adjusted and all doubt resolved. Escrow Agent shall have no liability for any loss arising from any cause beyond its control, including (but not limited to) the following: (a) the act, failure or neglect of any agent or correspondent selected by Escrow Agent for the remittance of funds; (b) any delay, error, omission or default of any mail, telegraph, cable or wireless agency or operator; (c) the acts or edicts of any government or governmental agency or other group or entity exercising governmental powers.

7. Right of Interpleader. Should any controversy arise between or among the Contract Parties or any other person, firm or entity with respect to this Agreement, the Deed, the Deposit, or any part thereof, or the right of any party or other person to receive the Deed or the Deposit, or should the Escrow Agent resign and the Contract Parties fail to designate another escrow agent, or if Escrow Agent should be in doubt as to what action to take, Escrow Agent

shall have the right, but not the obligation, either to: (a) withhold delivery of the Assignment until the controversy is resolved, the conflicting demands are withdrawn, or its doubt is resolved, or (b) institute a bill of interpleader in any court of competent jurisdiction to determine the rights of the parties hereto. Should a bill of interpleader be instituted, or should Escrow Agent be threatened with litigation or become involved in litigation in any manner whatsoever on account of this Agreement, then, as between themselves and Escrow Agent, the Contract Parties jointly and severally hereby bind and obligate themselves, their successors and assigns, to pay to Escrow Agent its attorney's fees and any and all other disbursements, expenses, losses, costs and damages of Escrow Agent in connection with or resulting from such threatened or actual litigation.

8. Scope of Duties and Errors in Judgment. Without in any way limiting any other provision of this Agreement, it is expressly understood and agreed that Escrow Agent shall be under no duty or obligation to give any notice, or to do or to omit the doing of any action or anything with respect to the Deed or Deposit, except to receive, hold and deliver the Deed and Deposit in accordance with the terms of this Agreement. Escrow Agent shall not be liable for any error in judgment, any act or omission, any mistake of law or fact, or for anything it may do or refrain from doing in connection herewith, except for its own willful misconduct or gross negligence.

9. Indemnity. To the extent allowed by law, the Contract Parties jointly and severally agree to indemnify Escrow Agent, its partners, employees, agents and counsel (each herein called an "Indemnified Party") against, and hold each Indemnified Party harmless from, any and all losses, costs, damages, claims, fees and other expenses of any kind or nature, including but not limited to attorneys' fees and costs of investigation, suffered or incurred by any Indemnified Party in connection with or arising from or out of this Agreement; except, however, that this indemnity will not cover claims or expenses which directly result from and are solely attributable to the willful misconduct or gross negligence of the Indemnified Party.

10. Notices. Any notice, communication, request, reply or advice (severally and collectively referred to as "Notice") in this Agreement provided or permitted to be given, made or accepted under the terms of this Agreement must be in writing. Notice may, unless otherwise provided herein, be given or served: (i) by depositing the same in the United States Mail, certified, with return receipt requested, addressed to the party to be notified and with all charges prepaid; or (ii) by depositing the same with Federal Express or another service guaranteeing "next day delivery", addressed to the party to be notified and with all charges prepaid; or (iii) by delivering the same to such party, or an agent of such party by electronic mail (email) or by hand delivery. Notice deposited in the United States mail in the manner hereinabove described shall be deemed effective from and after the earlier of the date of actual receipt or three (3) days after the date of such deposit. Notice given in any other manner shall be effective only if and when received by the party to be notified. For the purposes of notice, the addresses of the parties shall, until changed as provided below, be as follows:

SELLER

Chandler Creek, L.P.
260 E. Baker Street, Suite 100
Costa Mesa, CA 92626
Attn: Mr. Brian Burke
Email: bburke@burkegroup.net

with a copy to:

Burke Real Estate Group
260 E. Baker St., Suite 100
Costa Mesa, CA 92626
Attn: Mr. Ken Wheeler
Email: ken@burkegroup.net

With an additional copy to:

SELLER’S ATTORNEY

Armbrust & Brown, PLLC
100 Congress Avenue, Suite 1300
Austin, Texas 78701
Attn: Mr. Samuel D. Byars
Email: sbyars@abaustin.com

ESCROW AGENT

Independence Title Company
Attn: Julia Bechara
203 W. Main Street, Suite A
Pflugerville, Texas 78660
Email: jbechara@independencetitle.com

The parties to this Agreement shall have the right from time to time to change their respective addresses, and each shall have the right to specify as its address any other address within the United States of America by at least five (5) days written notice to the other parties. If any date or any period provided in this Agreement ends on a Saturday, Sunday or legal holiday, the applicable period shall be extended to the first business day following such Saturday, Sunday or legal holiday.

11. Consultation with Legal Counsel. Escrow Agent may consult with its counsel or other counsel satisfactory to it concerning any question relating to its duties or responsibilities hereunder or otherwise in connection herewith and shall not be liable for any action taken, suffered or omitted by Escrow Agent in good faith upon the advice of such counsel. Escrow Agent may act through its officers, employees, agents and attorneys.

PURCHASER

Williamson County Auditor’s Office
710 Main Street, Suite 101
Georgetown, TX 78626
Attn: Julie Kiley
Email: jkiley@wilco.org

with a copy to:

HNTB
101 East Old Settlers Blvd., Suite 100
Round Rock, Texas 78664
Attn: Mark Cissell
Email: mcissell@hntb.com

With an additional copy to:

PURCHASER’S ATTORNEY

Sheets & Crossfield, P.C.
309 East Main Street
Round Rock, Texas 78664
Attn: Mr. Don Childs
Email: don@scrllaw.com

12. Choice of Laws; Cumulative Rights. This Agreement and the Assignment shall be construed and regulated under, and their validity and effect shall be determined by, the laws of the State of Texas, including its conflict of law rules. Venue shall be in Williamson County, Texas. All of Escrow Agent's rights hereunder are cumulative of any other rights it may have by law or otherwise.

13. Resignation. Escrow Agent may resign upon ten (10) days' prior written notice to the Contract Parties and, upon joint instructions of the Contract Parties, shall deliver the Deed and the Deposit to any designated substitute Escrow Agent mutually selected by the Contract Parties. If the Contract Parties fail mutually to designate a substitute Escrow Agent within ten (10) days after the giving of such notice, Escrow Agent may, in its sole discretion and its sole option, institute a bill of interpleader in any court of competent jurisdiction to determine the rights of the parties hereto.

14. Severability. If one or more of the provisions hereof shall for any reason be held to be invalid, illegal or unenforceable in any respect under applicable law, such invalidity, illegality or unenforceability shall not affect any other provisions hereof, and this Agreement shall be construed as if such invalid, illegal or unenforceable provision had never been contained herein.

15. Termination. Upon delivery of the Assignment as provided in this Agreement the obligations and duties of Escrow Agent under this Agreement shall terminate.

16. Fees. Any fees required by Escrow Agent to perform the duties as set out herein shall be shared equally between Seller and Purchaser, and shall be payable prior to any disbursal under this Agreement.

17. General. The section headings contained in this Agreement are for reference purposes only and shall not affect in any way the meaning or interpretation of this Agreement. This Agreement may be executed in any number of counterparts and it shall not be necessary that the signatures of all parties be contained in any one (1) counterpart of this Agreement. The signature pages taken from separate individually executed counterparts of this Agreement may be combined to form multiple fully executed counterparts and facsimile signatures and signatures delivered by electronic mail shall be deemed to be original signatures for all purposes arising in connection with this Agreement. Each fully executed counterpart of this Agreement shall be deemed an original, but all of such counterparts shall constitute one and the same agreement. The terms and provisions of this Agreement constitute the entire agreement between the parties hereto. This Agreement or any provision hereof may be amended, modified, waived or terminated only by written instrument duly signed by the parties hereto or their successors and assigns. This Agreement shall inure to the benefit of and be binding upon the parties hereto, and their respective heirs, devisees, executors, administrators, personal representatives, successors, trustees, receivers and assigns. Nothing in this Agreement, express or implied, is intended to confer upon any other person rights or remedies under or by reason of this Agreement. This Agreement is intended to be performed in the State of Texas and shall be construed and enforced in accordance with the laws of such State.

IN WITNESS WHEREOF, the parties have executed this Agreement in multiple counterparts, each of which is and shall be considered an original for all intents and purposes, effective as of _____, 2018.

COUNTERPART SIGNATURE PAGE FOR ATTACHMENT TO ESCROW AGREEMENT
BY AND AMONG CHANDLER CREEK, L.P. AS SELLER,
WILLIAMSON COUNTY, TEXAS AS PURCHASER
AND INDEPENDENCE TITLE COMPANY AS ESCROW AGENT

SELLER:

CHANDLER CREEK, L.P., a Delaware limited partnership

By: CHANDLER CREEK COMPANY, a Delaware corporation, its General Partner

By: _____

Printed Name: _____

Title: _____

Date: _____

COUNTERPART SIGNATURE PAGE FOR ATTACHMENT TO ESCROW AGREEMENT
BY AND AMONG CHANDLER CREEK, L.P. AS SELLER,
WILLIAMSON COUNTY, TEXAS AS PURCHASER
AND INDEPENDENCE TITLE COMPANY AS ESCROW AGENT

PURCHASER:

WILLIAMSON COUNTY, TEXAS,

By: _____
Dan A. Gattis, County Judge

Date: _____

COUNTERPART SIGNATURE PAGE FOR ATTACHMENT TO ESCROW AGREEMENT
BY AND AMONG CHANDLER CREEK, L.P. AS SELLER,
WILLIAMSON COUNTY, TEXAS AS PURCHASER
AND INDEPENDENCE TITLE COMPANY AS ESCROW AGENT

ESCROW AGENT:

INDEPENDENCE TITLE COMPANY

By: _____

Name: _____

Title: _____

EXHIBIT "A"

Page 1 of 4
04/25/17

EXHIBIT A

County: Williamson
Parcel : 7
Highway: N. Mays

PROPERTY DESCRIPTION FOR PARCEL 7

DESCRIPTION OF A 0.398 ACRE (17,324 SQUARE FOOT) TRACT OF LAND SITUATED IN THE DAVID CURRY SURVEY, ABSTRACT NO. 130 AND THE EPHRAIM EVANS SURVEY, ABSTRACT NO. 212 IN WILLIAMSON COUNTY, TEXAS, BEING A PORTION OF LOT 3A, REPLAT OF LOT 3, OAKMONT CENTRE, SECTION ONE REVISED A SUBDIVISION OF RECORD IN CABINET BB, SLIDE 137-139 OF THE PLAT RECORDS OF WILLIAMSON COUNTY, TEXAS, CONVEYED TO CHANDLER CREEK, LP BY INSTRUMENT RECORDED IN DOCUMENT NO. 2000000444 OF THE OFFICIAL PUBLIC RECORDS OF WILLIAMSON COUNTY, TEXAS, SAID LOT 3A BEING FURTHER DECLARED AS THE OAKS AT CHANDLER CREEK COMMERCIAL CONDOMINIUMS BY DECLARATION OF CONDOMINIUM REGIME BY INSTRUMENT RECORDED IN DOCUMENT NO. 2007038901 OF THE OFFICIAL PUBLIC RECORDS OF WILLIAMSON COUNTY, TEXAS, SAID 0.398 ACRE (17,324 SQUARE FOOT) TRACT OF LAND BEING MORE PARTICULARLY DESCRIBED BY METES AND BOUNDS AS FOLLOWS:

BEGINNING FOR REFERENCE at a 1/2" iron rod found, being the southeasterly corner of Lot 2, Block "A", Final Plat of Cypress Addition, a subdivision of record in Cabinet N, Slide 266-268 of the Plat Records of Williamson County, Texas, same being the southeasterly corner of that called 13.110 acre tract of land conveyed to Round Rock Independent School District by instrument recorded in Document No. 2017016316 of the Official Public Records of Williamson County, Texas in the northerly Right-of-Way (ROW) line of Cypress Cove (60' ROW width) as dedicated by said Plat, also being the southwesterly corner of Lot 2, Oakmont Centre, Section One Revised, a subdivision of record in Cabinet F, Slide 129-133 of the Plat Records of Williamson County, Texas;

THENCE, departing said Cypress Cove, with the easterly boundary line of said Lot 2, Block "A" and said 13.110 acre tract, same being the westerly boundary line of said Lot 2 (Oakmont Centre), N 21°39'16" W, for a distance of 364.57 feet to a calculated angle point;

THENCE, continuing with said easterly boundary line of said Lot 2, Block "A" and said 13.110 acre tract, same being the westerly boundary line of said Lot 2, passing the northwesterly corner of said Lot 2, and continuing with the westerly boundary line of said Lot 3A, N 21°26'59" W, for a distance of 729.88 to a 1/2" iron rod with plastic cap stamped "CUNNINGHAM-ALLEN, INC" found, being the northerly corner of said 13.110 acre tract and an angle point in the proposed easterly ROW line;

THENCE, departing said 13.110 acre tract, continuing with said easterly boundary line of said Lot 2, Block "A" and the westerly boundary line of said Lot 3A with said proposed easterly ROW line, N 21°26'59" W, for a distance of 22.00 feet to a 1/2" iron rod with aluminum cap stamped "WILCO ROW-5050" set 75.00 feet right of proposed North Mays Baseline Station 71+94.40, (Grid Coordinates determined as N=10174787.65, E=3130231.58 (TxSPC Zone 4203), for the southwesterly corner and **POINT OF BEGINNING** of the herein described tract;

- 1) **THENCE**, departing said proposed easterly ROW line, continuing with the common boundary line of said Lot 2, Block "A" and said Lot 3A, N 21°26'59" W, for a distance of 151.31 feet to a 1/2" iron rod found, being the northeasterly corner of said Lot 2, Block "A", in the southerly boundary line of Lot 3, Block B, Oakmont Centre Section Five, a subdivision of record in Cabinet F, Slide 139-142 of the Plat Records of Williamson County, Texas, same being an angle point in the westerly boundary line of said Lot 3A, also being in the ostensible Survey Line between said David Curry Survey and said Ephraim Evans Survey, for an angle point;
- 2) **THENCE**, departing said Lot 2, Block "A", same being said ostensible Survey Line, with the common boundary line of said Lot 3, Block B and said Lot 3A, N 27°42'08" E, for a distance of 196.53 feet to a 1/2" iron rod found in the southwesterly ROW line of Oakmont Drive (60' ROW width), being the northwesterly corner of said Lot 3A, same being the southeasterly corner of said Lot 3, Block B, for the northerly corner of the herein described tract;

EXHIBIT "A"

PLAT TO ACCOMPANY PARCEL DESCRIPTION

04/25/17
PAGE 3 OF 4

NUMBER	DELTA	RADIUS	LENGTH	CHORD	CHORD BEARING
C1	44° 54' 51"	330.00'	258.69'	252.11'	S84° 47' 57" E
C2	14° 51' 49"	825.00'	214.02'	213.42'	S02° 31' 18" E
(C3)	(55° 44' 20")	(330.00')	(321.03')	(308.52')	(N89° 49' 00" E)

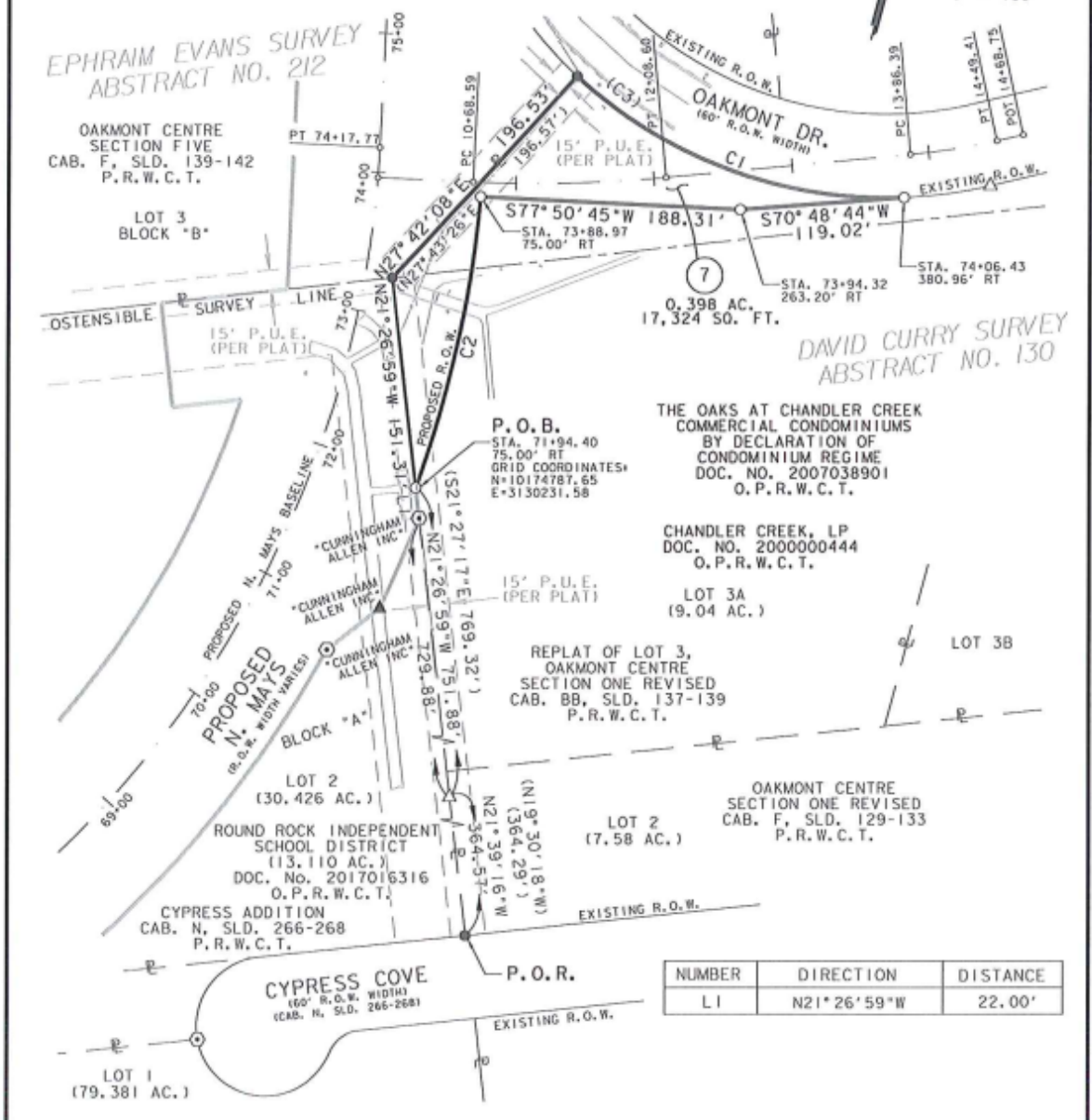
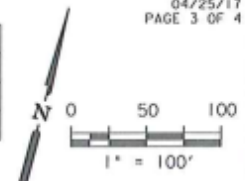

NUMBER	DIRECTION	DISTANCE
L1	N21° 26' 59" W	22.00'

INLAND U
GEODETICS
PROFESSIONAL LAND SURVEYORS
1504 CHISHOLM TRAIL RD. STE. 103
ROUND ROCK, TX. 78681
PH. (512) 238-1200, FAX (512) 238-1251
FIRM REGISTRATION NO. 100591-00

PARCEL PLAT SHOWING PROPERTY OF
CHANDLER CREEK, LP

SCALE 1" = 100'	PROJECT N. MAYS	COUNTY WILLIAMSON
--------------------	--------------------	----------------------

PARCEL 7

S:\L\JANMAYS\EXT\PARCELS\PARCEL 7 OAKS AT CHANDLER CREEK COMMERCIAL CONDOMINIUMS\OAKS AT CHANDLER CREEK COMMERCIAL CONDOMINIUMS-REV.dgn

LEGEND PLAT TO ACCOMPANY PARCEL DESCRIPTION

04/25/17
PAGE 4 OF 4

■	TXDOT TYPE I CONCRETE MONUMENT FOUND	⊥	CENTER LINE
#	FENCE CORNER POST FOUND	ℙ	PROPERTY LINE
●	1/2" IRON ROD FOUND UNLESS NOTED	()	RECORD INFORMATION
⊙	1/2" IRON ROD FOUND W/PLASTIC CAP	— —	LINE BREAK
⊙	COTTON GIN SPINDLE FOUND	↔	DENOTES COMMON OWNERSHIP
⊙	1/2" IRON PIPE FOUND UNLESS NOTED	P.O.B.	POINT OF BEGINNING
X	X CUT FOUND	P.O.R.	POINT OF REFERENCE
▲	MAG NAIL W/ WASHER FOUND	N.T.S.	NOT TO SCALE
△	CALCULATED POINT	D.R.W.C.T.	DEED RECORDS WILLIAMSON COUNTY, TEXAS
○	1/2" IRON ROD W/ ALUMINUM CAP STAMPED "WILCO-ROW-5050" SET (UNLESS NOTED OTHERWISE)	O.R.W.C.T.	OFFICIAL RECORDS WILLIAMSON COUNTY, TEXAS
		O.P.R.W.C.T.	OFFICIAL PUBLIC RECORDS WILLIAMSON COUNTY, TEXAS
		P.R.W.C.T.	PLAT RECORDS WILLIAMSON COUNTY, TEXAS

1) All bearings shown hereon are based on grid bearing. All distances are surface distances. Coordinates are surface values based on the Texas State Plane Coordinate System, NAD 83, Central Zone.

THE SURVEY SHOWN HEREON WAS PREPARED IN CONJUNCTION WITH THAT COMMITMENT FOR TITLE INSURANCE OF NO. 17-293994-GT, ISSUED BY FIRST NATIONAL TITLE INSURANCE COMPANY, EFFECTIVE DATE MARCH 5, 2017, ISSUE DATE MARCH 10, 2017.

- I. RESTRICTIVE COVENANTS: CABINET F, SLIDE 129; CABINET BB, SLIDE 137; PLAT RECORDS OF WILLIAMSON COUNTY, TEXAS, AND DOCUMENT NO(S). 2007038901, 2007038902, 2007072098, 2007095686, OFFICIAL PUBLIC RECORDS OF WILLIAMSON COUNTY, TEXAS, SUBJECT TO.
- 10G. THE EASEMENT(S) AND/OR BUILDING LINE(S) AFFECTING THE SUBJECT PROPERTY AS SHOWN ON MAP OR PLAT RECORDED IN CABINET F, SLIDES 129-133, PLAT RECORDS OF WILLIAMSON COUNTY, TEXAS, 15' P.U.E ALONG WESTERLY LINE AFFECTS AS SHOWN.
- H. THE EASEMENT(S) AND/OR BUILDING LINE(S) AFFECTING THE SUBJECT PROPERTY AS SHOWN ON MAP OR PLAT RECORDED IN CABINET BB, SLIDE 139, PLAT RECORDS OF WILLIAMSON COUNTY, TEXAS, 15' P.U.E ALONG WESTERLY LINE AFFECTS AS SHOWN.
- I. ELECTRIC EASEMENT TO TEXAS POWER & LIGHT COMPANY, RECORDED IN VOLUME 299, PAGE 402, DEED RECORDS OF WILLIAMSON COUNTY, TEXAS, AND AS SHOWN ACROSS LOT 1 OF TRACT ON PLAT RECORDED IN CABINET F, SLIDES 129-133, PLAT RECORDS OF WILLIAMSON COUNTY, TEXAS, DOES NOT AFFECT.
- J. JOINT ACCESS AGREEMENT BY AND BETWEEN OAKMONT CENTRE JOINT VENTURE AND KSP-ROUND ROCK, RECORDED IN VOLUME 1384, PAGE 626, OFFICIAL RECORDS OF WILLIAMSON COUNTY, TEXAS, DOES NOT AFFECT.
- K. JOINT ACCESS AGREEMENT BY AND BETWEEN OAKMONT CENTRE JOINT VENTURE AND KSP-ROUND ROCK, RECORDED IN VOLUME 1384, PAGE 641, OFFICIAL RECORDS OF WILLIAMSON COUNTY, TEXAS, DOES NOT AFFECT.
- M. EASEMENT CREATED IN INSTRUMENT TO ATMOS ENERGY CORPORATION, RECORDED IN DOCUMENT NO. 2006002468, OFFICIAL PUBLIC RECORDS OF WILLIAMSON COUNTY, TEXAS, DOES NOT AFFECT.
- N. WATER LINE EASEMENT TO CITY OF ROUND ROCK, RECORDED IN DOCUMENT NO. 2006070311, OFFICIAL PUBLIC RECORDS OF WILLIAMSON COUNTY, TEXAS. DOES NOT AFFECT.
- O. THE TERMS, PROVISIONS, EASEMENTS, COVENANTS, RESTRICTIONS AND LIEN FOR ASSESSMENTS AS SHOWN IN DECLARATION OF CONDOMINIUM REGIME, RECORDED IN DOCUMENT NO. 2007038901, OFFICIAL PUBLIC RECORDS WILLIAMSON COUNTY, TEXAS, WHEN TAKEN WITH ALL AMENDMENTS AND/OR SUPPLEMENTS THERETO, INCLUDING BUT NOT LIMITED TO DOCUMENT NO. 2007038902, OFFICIAL PUBLIC RECORDS OF WILLIAMSON COUNTY, TEXAS, IF APPLICABLE, SUBJECT TO.
- P. TERMS, CONDITIONS, STIPULATIONS, PROVISIONS, AND EASEMENTS CONTAINED IN THE AGREEMENT REGARDING MAINTENANCE OF DRAINAGE FACILITIES, BY AND BETWEEN CHANDLER CREEK, LP, A DELAWARE LIMITED PARTNERSHIP, AND THE OAKS AT CHANDLER CREEK COMMERCIAL CONDOMINIUM COMMUNITY, INC., A TEXAS NON-PROFIT CORPORATION, RECORDED IN DOCUMENT NO. 2007095686, OFFICIAL PUBLIC RECORDS OF WILLIAMSON COUNTY, TEXAS, IF APPLICABLE, SUBJECT TO.

I HEREBY CERTIFY THAT THIS PLAT IS TRUE AND CORRECT TO THE BEST OF MY KNOWLEDGE AND BELIEF AND THAT THE PROPERTY SHOWN HEREIN WAS DETERMINED BY A SURVEY MADE ON THE GROUND UNDER MY DIRECT SUPERVISION.

Lawrence M. Russo 05/03/2017
 LAWRENCE M. RUSSO
 REGISTERED PROFESSIONAL LAND SURVEYOR NO. 5050
 INLAND GEODETICS, LLC
 FIRM REGISTRATION NO. 100591-00
 1504 CHISHOLM TRAIL ROAD, SUITE 103
 ROUND ROCK, TX 78681



	ACRES	SQUARE FEET
ACQUISITION	0.398	17,324
CALC./DEED AREA	9.04	393,782
REMAINDER AREA	8.642	376,458

PARCEL PLAT SHOWING PROPERTY OF		
CHANDLER CREEK, LP		
SCALE	PROJECT	COUNTY
1" = 100'	N. MAYS	WILLIAMSON

PARCEL 7

S:\L\MAYS EXT\PARCELS\PARCEL 7 OAKS AT CHANDLER CREEK COMMERCIAL CONDOMINIUMS\OAKS AT CHANDLER CREEK COMMERCIAL CONDOMINIUMS-REV.dgn

EXHIBIT "B"

Parcel 7

DEED

North Mays Extension Right of Way

THE STATE OF TEXAS

§

§

COUNTY OF WILLIAMSON

§

NOTICE OF CONFIDENTIALITY RIGHTS: IF YOU ARE A NATURAL PERSON, YOU MAY REMOVE OR STRIKE ANY OF THE FOLLOWING INFORMATION FROM THIS INSTRUMENT BEFORE IT IS FILED IN THE PUBLIC RECORDS: YOUR SOCIAL SECURITY NUMBER OR YOUR DRIVER'S LICENSE NUMBER.

NOW, THEREFORE, KNOW ALL BY THESE PRESENT:

That CHANDLER CREEK, LP, a Delaware limited partnership, hereinafter referred to as Grantor, whether one or more, for and in consideration of the sum of Ten Dollars (\$10.00) and other good and valuable consideration to Grantor in hand paid by Williamson County, Texas, the receipt and sufficiency of which is hereby acknowledged, and for which no lien is retained, either expressed or implied, have this day Sold and by these presents do Grant, Bargain, Sell and Convey unto WILLIAMSON COUNTY, TEXAS, all that certain tract or parcel of land lying and being situated in the County of Williamson, State of Texas, along with any improvements thereon, being more particularly described as follows:

All of that certain 0.398 acre (17,324 Sq. Ft.) of land in the David Curry Survey, Abstract No. 130, and the Ephraim Evans Survey, Abstract No. 212, Williamson County, Texas; being more fully described by metes and bounds in Exhibit "A", attached hereto and incorporated herein (**Parcel 7**).

SAVE AND EXCEPT, HOWEVER, it is expressly understood and agreed that Grantor is retaining title to the following improvements located on the property described in said Exhibit "A" to wit: NONE

RESERVATIONS FROM AND EXCEPTIONS TO CONVEYANCE AND WARRANTY:

Visible and apparent easements not appearing of record;

Any discrepancies, conflicts, or shortages in area or boundary lines or any encroachments or any overlapping of improvements which a current survey would show;

Easements, restrictions, reservations, covenants, conditions, oil and gas leases, mineral severances, and encumbrances for taxes and assessments (other than liens and conveyances) presently of record in the Official Public Records of Williamson County, Texas, that affect the property, but only to the extent that said items are still valid and in force and effect at this time.

Grantor reserves all of the oil, gas and other minerals in and under the land herein conveyed but waives all rights of ingress and egress to the surface thereof for the purpose of exploring, developing, mining or drilling or pumping the same; provided, however, that operations for exploration or recovery of any such minerals shall be permissible so long as all surface operations in connection therewith are located at a point outside the acquired parcel and upon the condition that none of such operations shall be conducted so near the surface of said land as to interfere with the intended use thereof or in any way interfere with, jeopardize, or endanger the facilities of Williamson County, Texas/City of Round Rock, Texas or create a hazard to the public users thereof; it being intended, however, that nothing in this reservation shall affect the title and the rights of Grantee to take and use without additional compensation any, stone, earth, gravel, caliche, iron ore, gravel or any other road building material.

TO HAVE AND TO HOLD the property herein described and herein conveyed together with all and singular the rights and appurtenances thereto in any wise belonging (insofar, but only insofar as such appurtenances benefit only the property described herein and not any other property; Grantor hereby reserving and retaining all such appurtenances insofar as the same relate to or benefit any property other than the property conveyed hereunder) unto Williamson County, Texas and its assigns forever; and Grantor does hereby bind itself, its heirs, executors, administrators, successors and assigns to Warrant and Forever Defend all and singular the said premises herein conveyed unto Williamson County, Texas and its assigns against every person whomsoever lawfully claiming or to claim the same or any part thereof, by, through or under Grantor, but not otherwise.

GRANTOR HAS EXECUTED AND DELIVERED THIS DEED AND HAS CONVEYED THE PROPERTY AND GRANTEE HAS RECEIVED AND ACCEPTED THIS DEED AND HAS ACCEPTED THE PROPERTY "AS IS", "WHERE IS", AND "WITH ALL FAULTS" AND WITHOUT REPRESENTATIONS OR WARRANTIES WHATSOEVER, EXPRESS OR IMPLIED, WRITTEN OR ORAL, EXCEPT FOR THE WARRANTIES SET OUT IN THIS DEED (THE "EXPRESS WARRANTIES"). AS A MATERIAL PART OF THE CONSIDERATION FOR GRANTOR'S CONVEYANCE OF THE PROPERTY TO GRANTEE, GRANTOR AND GRANTEE AGREE AND ACKNOWLEDGE THAT: (A) EXCEPT ONLY WITH RESPECT TO THE EXPRESS WARRANTIES, GRANTEE IS TAKING THE PROPERTY "AS-IS" WITH ANY AND ALL LATENT AND PATENT DEFECTS; (B) EXCEPT ONLY WITH RESPECT TO THE EXPRESS WARRANTIES, THERE IS NO WARRANTY BY GRANTOR THAT THE PROPERTY IS FIT FOR ANY PARTICULAR PURPOSE; (C) EXCEPT ONLY WITH RESPECT TO THE EXPRESS WARRANTIES, GRANTEE IS NOT RELYING ON THE ACCURACY OR COMPLETENESS OF ANY REPRESENTATION, BROCHURE, RENDERING, PROMISE, STATEMENT OR OTHER ASSERTION OR INFORMATION WITH RESPECT TO THE PROPERTY MADE OR FURNISHED BY OR ON BEHALF OF, OR OTHERWISE ATTRIBUTED TO, GRANTOR OR ANY OF GRANTOR'S AGENTS, EMPLOYEES OR REPRESENTATIVES, ANY AND ALL SUCH RELIANCE BEING HEREBY EXPRESSLY AND UNEQUIVOCALLY DISCLAIMED; (D) EXCEPT ONLY WITH RESPECT TO THE EXPRESS WARRANTIES, GRANTEE IS RELYING SOLELY AND EXCLUSIVELY UPON ITS OWN EXPERIENCE AND ITS INDEPENDENT JUDGMENT, EVALUATION AND EXAMINATION OF THE PROPERTY; (E) EXCEPT ONLY WITH RESPECT TO THE EXPRESS WARRANTIES, GRANTEE DISCLAIMS (I) THE EXISTENCE OF ANY DUTY TO DISCLOSE ON THE PART OF GRANTOR OR ANY OF

GRANTOR'S AGENTS, EMPLOYEES OR REPRESENTATIVES AND (II) ANY RELIANCE BY GRANTEE ON THE SILENCE OR ANY NONDISCLOSURE OF GRANTOR OR ANY OF GRANTOR'S AGENTS, EMPLOYEES OR REPRESENTATIVES; (F) GRANTEE TAKES AND ACCEPTS THE PROPERTY WITHOUT ANY EXPRESS OR IMPLIED WARRANTIES OF ANY KIND (EXCEPT FOR THE EXPRESS WARRANTIES); (G) EXCEPT FOR THE EXPRESS WARRANTIES, NO PROMISES OR AGREEMENTS HAVE BEEN MADE BY GRANTOR TO GRANTEE WITH RESPECT TO THE PROPERTY AND GRANTEE HEREBY DISCLAIMS ANY RELIANCE UPON ANY PROMISES OR AGREEMENTS OTHER THAN THE EXPRESS WARRANTIES; (H) THIS "AS IS" PROVISION WAS FREELY NEGOTIATED AND PLAYED AN IMPORTANT PART IN THE BARGAINING PROCESS BY WHICH GRANTOR AGREED TO CONVEY THE PROPERTY TO GRANTEE; (I) GRANTEE DISCLAIMS RELIANCE ON GRANTOR AND ACCEPTS THE PROPERTY "AS-IS" WITH FULL AWARENESS THAT THE PROPERTY'S PRIOR USES AND OTHER DISCLAIMED MATTERS COULD AFFECT THE PROPERTY'S CONDITION, VALUE, SUITABILITY OR FITNESS AND GRANTEE HEREBY ASSUMES ALL RISK ASSOCIATED THEREWITH; (J) THE DISCLAIMERS OF RELIANCE AND OTHER PROVISIONS CONTAINED IN THIS "AS IS" PROVISION COULD LIMIT ANY LEGAL RECOURSE OR REMEDY GRANTEE OTHERWISE MIGHT HAVE; AND (K) GRANTEE HAS RELIED UPON THE ADVICE OF ITS OWN LEGAL COUNSEL CONCERNING THIS "AS IS" PROVISION.

This deed is being delivered in lieu of condemnation.

IN WITNESS WHEREOF, this instrument is executed on this the _____ day of _____, 2018.

[signature page follows]

GRANTOR:

CHANDLER CREEK, LP,
a Delaware limited partnership

By: CHANDLER CREEK COMPANY,
a Delaware corporation, its General Partner

By: _____

Its: _____

Date: _____

ACKNOWLEDGMENT

A notary public or other officer completing this certificate verifies only the identity of the individual who signed the document to which this certificate is attached, and not the truthfulness, accuracy, or validity of that document.

STATE OF CALIFORNIA)
County of _____)

On _____, 2018 before me, _____, a Notary Public, personally appeared _____, who proved to me on the basis of satisfactory evidence to be the person(s) whose name(s) is/are subscribed to the within instrument and acknowledged to me that he/she/they executed the same in his/her/their authorized capacity(ies), and that by his/her/their signature(s) on the instrument the person(s), or the entity upon behalf of which the person(s) acted, executed the instrument.

I certify under penalty of perjury under the laws of the State of California that the foregoing paragraph is true and correct.

Witness my hand and official seal

Signature: _____ (Seal)

PREPARED IN THE OFFICE OF:

Sheets & Crossfield, P.C.
309 East Main
Round Rock, Texas 78664

GRANTEE'S MAILING ADDRESS:

Williamson County, Texas
Attn: County Auditor
710 Main Street, Suite 101
Georgetown, Texas 78626

AFTER RECORDING RETURN TO:

WAIVER OF IMMUNITY

This Waiver of Immunity (“Waiver”) is made by and between **WILLIAMSON COUNTY, TEXAS**, (“Williamson County”), and **CHANDLER CREEK, LP**, a Delaware limited partnership (“Chandler Creek”) and is as follows:

1. Property. The “Property” means the real property which is described on **Exhibit “A”** attached to this Waiver and incorporated herein by reference, together with all buildings, structures and other improvements located thereon.
2. The Real Estate Contract. The “Real Estate Contract” means and refers to that certain “Real Estate Contract” dated January 23, 2018, pursuant to which Chandler Creek has agreed to sell and convey the Property to Williamson County (the “Real Estate Contract”).
3. Waiver of Immunity. Pursuant to the provisions of the Real Estate Contract, Williamson County hereby waives all rights to immunity solely and specifically with respect to the obligations of Williamson County under Section 2.03 of the Real Estate Contract, including without limitation all rights to immunity from liability and all rights to immunity from suit. This waiver is agreed to by Williamson County for the benefit of Chandler Creek and is entered into by Williamson County for good and valuable consideration and pursuant to the terms and provisions of the Real Estate Contract.
4. Legal Expenses. If either party to this Waiver brings suit or otherwise becomes involved in any legal proceedings seeking to enforce the terms of this Waiver, or to recover damages for their breach, the prevailing party shall be entitled to recover its costs and expenses (including reasonable fees of attorneys, expert witnesses, accountants, court reporters and others) incurred in connection therewith including all such costs and expenses incurred: (a) in trial and appellate court proceedings, (b) in connection with any and all counterclaims asserted by one party to this Waiver against another where such counterclaims arise out of or are otherwise related to this Waiver, (c) in bankruptcy or other insolvency proceedings, and (d) in post-judgment collection proceedings.
5. Authority. Williamson County warrants and represents to Chandler that: (a) the execution and delivery of this Waiver has been duly authorized by all necessary corporate and governmental action of Williamson County; and (b) this Waiver has been duly executed and delivered by Williamson County, and constitutes a legal, valid, and binding obligation of Williamson County, enforceable in accordance with its terms as of the effective date of this Waiver.
6. Governing Law and Venue. It is agreed that: (a) the laws of the State of Texas shall govern this Waiver; and (b) venue for any suit under the terms of this Waiver shall be in Williamson County, Texas.
7. Binding Agreement. This Waiver is binding upon Williamson County and inures to the benefit of Chandler Creek and its successors and assigns.

8. Partial Invalidity. A determination that any provision of this Waiver is unenforceable or invalid shall not affect the enforceability or the validity of any other provision.

9. Entire Agreement. This Waiver and the Real Estate Contract represent the entire agreement between the parties hereto as to the waiver granted hereunder and the same supersede all prior negotiations, representations or agreements, either written or oral, regarding such subject matter. No amendments or modifications to this Waiver and no other statements, agreements or other understandings regarding the subject matter of this Waiver will be recognized or enforced unless the same are in writing and signed by both Williamson County and Chandler Creek subsequent to the effective date of this Waiver.

EXECUTED AND DELIVERED by Williamson County and Chandler Creek on the date set out herein below.

ASSIGNOR:

WILLIAMSON COUNTY, TEXAS

By: _____
Dan A. Gattis, County Judge

Date: _____

THE STATE OF TEXAS §

COUNTY OF WILLIAMSON§

This instrument was acknowledged before me this ____ day of _____, 2018 by Dan A. Gattis, County Judge of Williamson County, Texas, , in the capacity and for the purposes and consideration recited herein.

(SEAL)

Notary Public Signature

AGREED AND ACCEPTED:

CHANDLER CREEK, LP,

a Delaware limited partnership

By: CHANDLER CREEK COMPANY,

a Delaware corporation, its General Partner

By: _____

Its: _____

Date: _____

ACKNOWLEDGMENT

A notary public or other officer completing this certificate verifies only the identity of the individual who signed the document to which this certificate is attached, and not the truthfulness, accuracy, or validity of that document.

STATE OF CALIFORNIA)

County of _____)

On _____, 2018 before me, _____, a Notary Public, personally appeared _____, who proved to me on the basis of satisfactory evidence to be the person(s) whose name(s) is/are subscribed to the within instrument and acknowledged to me that he/she/they executed the same in his/her/their authorized capacity(ies), and that by his/her/their signature(s) on the instrument the person(s), or the entity upon behalf of which the person(s) acted, executed the instrument.

I certify under penalty of perjury under the laws of the State of California that the foregoing paragraph is true and correct.

Witness my hand and official seal

Signature: _____

(Seal)

Exhibit A

Page 1 of 4
04/25/17

EXHIBIT A

County: Williamson
Parcel : 7
Highway: N. Mays

PROPERTY DESCRIPTION FOR PARCEL 7

DESCRIPTION OF A 0.398 ACRE (17,324 SQUARE FOOT) TRACT OF LAND SITUATED IN THE DAVID CURRY SURVEY, ABSTRACT NO. 130 AND THE EPHRAIM EVANS SURVEY, ABSTRACT NO. 212 IN WILLIAMSON COUNTY, TEXAS, BEING A PORTION OF LOT 3A, REPLAT OF LOT 3, OAKMONT CENTRE, SECTION ONE REVISED A SUBDIVISION OF RECORD IN CABINET BB, SLIDE 137-139 OF THE PLAT RECORDS OF WILLIAMSON COUNTY, TEXAS, CONVEYED TO CHANDLER CREEK, LP BY INSTRUMENT RECORDED IN DOCUMENT NO. 2000000444 OF THE OFFICIAL PUBLIC RECORDS OF WILLIAMSON COUNTY, TEXAS, SAID LOT 3A BEING FURTHER DECLARED AS THE OAKS AT CHANDLER CREEK COMMERCIAL CONDOMINIUMS BY DECLARATION OF CONDOMINIUM REGIME BY INSTRUMENT RECORDED IN DOCUMENT NO. 2007038901 OF THE OFFICIAL PUBLIC RECORDS OF WILLIAMSON COUNTY, TEXAS, SAID 0.398 ACRE (17,324 SQUARE FOOT) TRACT OF LAND BEING MORE PARTICULARLY DESCRIBED BY METES AND BOUNDS AS FOLLOWS:

BEGINNING FOR REFERENCE at a 1/2" iron rod found, being the southeasterly corner of Lot 2, Block "A", Final Plat of Cypress Addition, a subdivision of record in Cabinet N, Slide 266-268 of the Plat Records of Williamson County, Texas, same being the southeasterly corner of that called 13.110 acre tract of land conveyed to Round Rock Independent School District by instrument recorded in Document No. 2017016316 of the Official Public Records of Williamson County, Texas in the northerly Right-of-Way (ROW) line of Cypress Cove (60' ROW width) as dedicated by said Plat, also being the southwesterly corner of Lot 2, Oakmont Centre, Section One Revised, a subdivision of record in Cabinet F, Slide 129-133 of the Plat Records of Williamson County, Texas;

THENCE, departing said Cypress Cove, with the easterly boundary line of said Lot 2, Block "A" and said 13.110 acre tract, same being the westerly boundary line of said Lot 2 (Oakmont Centre), N 21°39'16" W, for a distance of 364.57 feet to a calculated angle point;

THENCE, continuing with said easterly boundary line of said Lot 2, Block "A" and said 13.110 acre tract, same being the westerly boundary line of said Lot 2, passing the northwesterly corner of said Lot 2, and continuing with the westerly boundary line of said Lot 3A, N 21°26'59" W, for a distance of 729.88 to a 1/2" iron rod with plastic cap stamped "CUNNINGHAM-ALLEN, INC" found, being the northerly corner of said 13.110 acre tract and an angle point in the proposed easterly ROW line;

THENCE, departing said 13.110 acre tract, continuing with said easterly boundary line of said Lot 2, Block "A" and the westerly boundary line of said Lot 3A with said proposed easterly ROW line, N 21°26'59" W, for a distance of 22.00 feet to a 1/2" iron rod with aluminum cap stamped "WILCO ROW-5050" set 75.00 feet right of proposed North Mays Baseline Station 71+94.40, (Grid Coordinates determined as N=10174787.85, E=3130231.58 (TxSPC Zone 4203), for the southwesterly corner and **POINT OF BEGINNING** of the herein described tract;

- 1) **THENCE**, departing said proposed easterly ROW line, continuing with the common boundary line of said Lot 2, Block "A" and said Lot 3A, N 21°26'59" W, for a distance of 151.31 feet to a 1/2" iron rod found, being the northeasterly corner of said Lot 2, Block "A", in the southerly boundary line of Lot 3, Block B, Oakmont Centre Section Five, a subdivision of record in Cabinet F, Slide 139-142 of the Plat Records of Williamson County, Texas, same being an angle point in the westerly boundary line of said Lot 3A, also being in the ostensible Survey Line between said David Curry Survey and said Ephraim Evans Survey, for an angle point;
- 2) **THENCE**, departing said Lot 2, Block "A", same being said ostensible Survey Line, with the common boundary line of said Lot 3, Block B and said Lot 3A, N 27°42'08" E, for a distance of 196.53 feet to a 1/2" iron rod found in the southwesterly ROW line of Oakmont Drive (60' ROW width), being the northwesterly corner of said Lot 3A, same being the southeasterly corner of said Lot 3, Block B, for the northerly corner of the herein described tract;

EXHIBIT "A"

PLAT TO ACCOMPANY PARCEL DESCRIPTION

04/25/17
PAGE 3 OF 4

NUMBER	DELTA	RADIUS	LENGTH	CHORD	CHORD BEARING
C1	44° 54' 51"	330.00'	258.69'	252.11'	S84° 47' 57" E
C2	14° 51' 49"	825.00'	214.02'	213.42'	S02° 31' 18" E
(C3)	(55° 44' 20")	(330.00')	(321.03')	(308.52')	(N89° 49' 00" E)

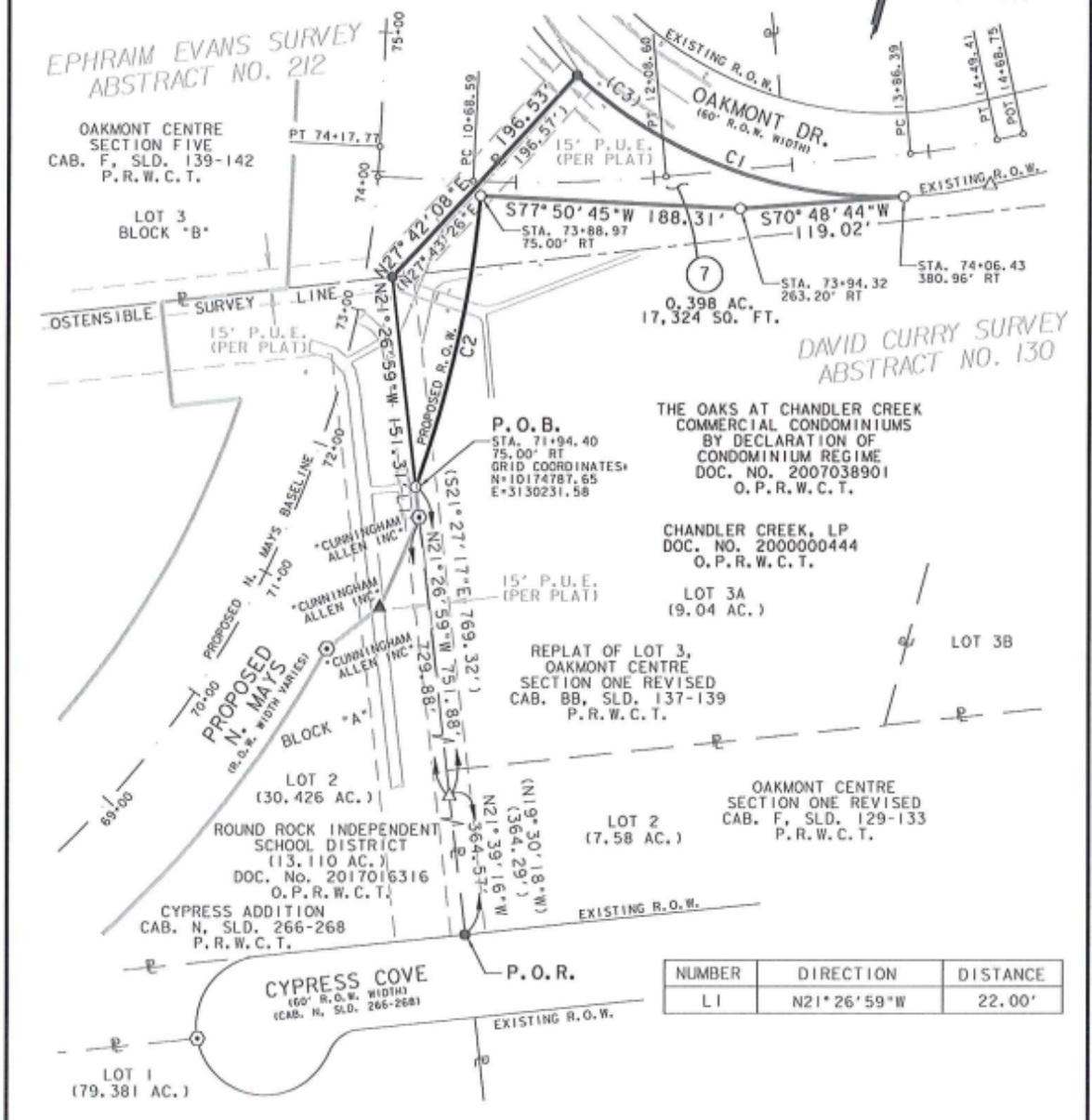
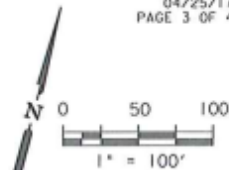

NUMBER	DIRECTION	DISTANCE
L1	N21° 26' 59" W	22.00'

INLAND GEODETICS
 PROFESSIONAL LAND SURVEYORS
 1504 CHISHOLM TRAIL RD. STE. 103
 ROUND ROCK, TX. 78681
 PH. (512) 238-1200, FAX (512) 238-1251
 FIRM REGISTRATION NO. 100591-00

PARCEL PLAT SHOWING PROPERTY OF
CHANDLER CREEK, LP

SCALE 1" = 100'	PROJECT N. MAYS	COUNTY WILLIAMSON
--------------------	--------------------	----------------------

PARCEL 7

S:\L\JANMAYS\EXT\PARCELS\PARCEL 7 OAKS AT CHANDLER CREEK COMMERCIAL CONDOMINIUMS\OAKS AT CHANDLER CREEK COMMERCIAL CONDOMINIUMS-REV.dgn

LEGEND PLAT TO ACCOMPANY PARCEL DESCRIPTION

04/25/17
PAGE 4 OF 4

■	TXDOT TYPE I CONCRETE MONUMENT FOUND	⊥	CENTER LINE
#	FENCE CORNER POST FOUND	ℙ	PROPERTY LINE
●	1/2" IRON ROD FOUND UNLESS NOTED	()	RECORD INFORMATION
⊙	1/2" IRON ROD FOUND W/PLASTIC CAP	— —	LINE BREAK
⊙	COTTON GIN SPINDLE FOUND	↕	DENOTES COMMON OWNERSHIP
⊙	1/2" IRON PIPE FOUND UNLESS NOTED	P.O.B.	POINT OF BEGINNING
X	X CUT FOUND	P.O.R.	POINT OF REFERENCE
▲	MAG NAIL W/ WASHER FOUND	N.T.S.	NOT TO SCALE
△	CALCULATED POINT	D.R.W.C.T.	DEED RECORDS WILLIAMSON COUNTY, TEXAS
○	1/2" IRON ROD W/ ALUMINUM CAP STAMPED "WILCO-ROW-5050" SET (UNLESS NOTED OTHERWISE)	O.R.W.C.T.	OFFICIAL RECORDS WILLIAMSON COUNTY, TEXAS
		O.P.R.W.C.T.	OFFICIAL PUBLIC RECORDS WILLIAMSON COUNTY, TEXAS
		P.R.W.C.T.	PLAT RECORDS WILLIAMSON COUNTY, TEXAS

1) All bearings shown hereon are based on grid bearing. All distances are surface distances. Coordinates are surface values based on the Texas State Plane Coordinate System, NAD 83, Central Zone.

THE SURVEY SHOWN HEREON WAS PREPARED IN CONJUNCTION WITH THAT COMMITMENT FOR TITLE INSURANCE OF NO. 17-293994-GT, ISSUED BY FIRST NATIONAL TITLE INSURANCE COMPANY, EFFECTIVE DATE MARCH 5, 2017, ISSUE DATE MARCH 10, 2017.

- I. RESTRICTIVE COVENANTS: CABINET F, SLIDE 129; CABINET BB, SLIDE 137; PLAT RECORDS OF WILLIAMSON COUNTY, TEXAS, AND DOCUMENT NO(S), 2007038901, 2007038902, 2007072098, 2007095686, OFFICIAL PUBLIC RECORDS OF WILLIAMSON COUNTY, TEXAS, SUBJECT TO.
- 10G. THE EASEMENT(S) AND/OR BUILDING LINE(S) AFFECTING THE SUBJECT PROPERTY AS SHOWN ON MAP OR PLAT RECORDED IN CABINET F, SLIDES 129-133, PLAT RECORDS OF WILLIAMSON COUNTY, TEXAS, 15' P.U.E ALONG WESTERLY LINE AFFECTS AS SHOWN.
- H. THE EASEMENT(S) AND/OR BUILDING LINE(S) AFFECTING THE SUBJECT PROPERTY AS SHOWN ON MAP OR PLAT RECORDED IN CABINET BB, SLIDE 139, PLAT RECORDS OF WILLIAMSON COUNTY, TEXAS, 15' P.U.E ALONG WESTERLY LINE AFFECTS AS SHOWN.
- I. ELECTRIC EASEMENT TO TEXAS POWER & LIGHT COMPANY, RECORDED IN VOLUME 299, PAGE 402, DEED RECORDS OF WILLIAMSON COUNTY, TEXAS, AND AS SHOWN ACROSS LOT 1 OF TRACT ON PLAT RECORDED IN CABINET F, SLIDES 129-133, PLAT RECORDS OF WILLIAMSON COUNTY, TEXAS, DOES NOT AFFECT.
- J. JOINT ACCESS AGREEMENT BY AND BETWEEN OAKMONT CENTRE JOINT VENTURE AND KSP-ROUND ROCK, RECORDED IN VOLUME 1384, PAGE 626, OFFICIAL RECORDS OF WILLIAMSON COUNTY, TEXAS, DOES NOT AFFECT.
- K. JOINT ACCESS AGREEMENT BY AND BETWEEN OAKMONT CENTRE JOINT VENTURE AND KSP-ROUND ROCK, RECORDED IN VOLUME 1384, PAGE 641, OFFICIAL RECORDS OF WILLIAMSON COUNTY, TEXAS, DOES NOT AFFECT.
- M. EASEMENT CREATED IN INSTRUMENT TO ATMOS ENERGY CORPORATION, RECORDED IN DOCUMENT NO. 2006002468, OFFICIAL PUBLIC RECORDS OF WILLIAMSON COUNTY, TEXAS, DOES NOT AFFECT.
- N. WATER LINE EASEMENT TO CITY OF ROUND ROCK, RECORDED IN DOCUMENT NO. 2006070311, OFFICIAL PUBLIC RECORDS OF WILLIAMSON COUNTY, TEXAS, DOES NOT AFFECT.
- O. THE TERMS, PROVISIONS, EASEMENTS, COVENANTS, RESTRICTIONS AND LIEN FOR ASSESSMENTS AS SHOWN IN DECLARATION OF CONDOMINIUM REGIME, RECORDED IN DOCUMENT NO. 2007038901, OFFICIAL PUBLIC RECORDS WILLIAMSON COUNTY, TEXAS, WHEN TAKEN WITH ALL AMENDMENTS AND/OR SUPPLEMENTS THERETO, INCLUDING BUT NOT LIMITED TO DOCUMENT NO. 2007038902, OFFICIAL PUBLIC RECORDS OF WILLIAMSON COUNTY, TEXAS, IF APPLICABLE, SUBJECT TO.
- P. TERMS, CONDITIONS, STIPULATIONS, PROVISIONS, AND EASEMENTS CONTAINED IN THE AGREEMENT REGARDING MAINTENANCE OF DRAINAGE FACILITIES, BY AND BETWEEN CHANDLER CREEK, LP, A DELAWARE LIMITED PARTNERSHIP, AND THE OAKS AT CHANDLER CREEK COMMERCIAL CONDOMINIUM COMMUNITY, INC., A TEXAS NON-PROFIT CORPORATION, RECORDED IN DOCUMENT NO. 2007095686, OFFICIAL PUBLIC RECORDS OF WILLIAMSON COUNTY, TEXAS, IF APPLICABLE, SUBJECT TO.

I HEREBY CERTIFY THAT THIS PLAT IS TRUE AND CORRECT TO THE BEST OF MY KNOWLEDGE AND BELIEF AND THAT THE PROPERTY SHOWN HEREIN WAS DETERMINED BY A SURVEY MADE ON THE GROUND UNDER MY DIRECT SUPERVISION.

Lawrence M. Russo 05/03/2017
 LAWRENCE M. RUSSO
 REGISTERED PROFESSIONAL LAND SURVEYOR NO. 5050
 INLAND GEODETICS, LLC
 FIRM REGISTRATION NO. 100591-00
 1504 CHISHOLM TRAIL ROAD, SUITE 103
 ROUND ROCK, TX 78681



	ACRES	SQUARE FEET
ACQUISITION	0.398	17,324
CALC/DEED AREA	9.04	393,782
REMAINDER AREA	8.642	376,458

INLAND U
GEODETICS
 PROFESSIONAL LAND SURVEYORS
 1504 CHISHOLM TRAIL RD, STE. 103
 ROUND ROCK, TX 78681
 PH. (512) 238-1200, FAX (512) 238-1251
 FIRM REGISTRATION NO. 100591-00

PARCEL PLAT SHOWING PROPERTY OF
CHANDLER CREEK, LP

SCALE	PROJECT	COUNTY
1" = 100'	N. MAYS	WILLIAMSON

PARCEL 7

S:\L\MAYS\EXT\PARCELS\PARCEL 7 OAKS AT CHANDLER CREEK COMMERCIAL CONDOMINIUMS\OAKS AT CHANDLER CREEK COMMERCIAL CONDOMINIUMS-REV.dgn

Commissioners Court - Regular Session

39.

Meeting Date: 02/27/2018

Amend 2014 Participation Enrollment for tax benefit financing for Williamson County Conservation Foundation

Submitted For: Gary Boyd

Submitted By: Gary Boyd, Parks

Department: Parks

Agenda Category: Regular Agenda Items

Information

Agenda Item

Discuss and take appropriate action to amend 2014 Tax Benefit Financing enrollment list to include Bar-W Ranch (formerly Wedemeyer Ranch) under Williamson County Conservation Foundation File number 20141223.

Background

The recommended action is to enroll the tracts associated with WCCF file 2141223 for the calendar year 2014 and start tax benefit calculations effective with the 2016 tax year for initial contributions in FY 2018. This includes Williamson Central Appraisal District (WCAD) reference tracts R022220, R032260, R032261, R451803, R485001, R485224, R485225, R491371, R491374, R523943, R523945, R523947, R021711, R344166, and R491376 and subsequent tracts, if any (i.e.; descendant tracts from parent tracts) if not captured in the 2014 enrollment.

Wedemeyer Ranch (WCCF File 20141223) applied for participation in December 2014 but did not complete the Determination Letter until early in 2015. The enrollment did not get picked up for 2014 tax benefit enrollments and was missed when the 2015 enrollment list was compiled.

So as not to complicate past year audit calculations the proposal is to utilize the year of enrollment to set the participation basis value and to skip to 2016 tax year for calculations and to 2018 FY audit valuation for initial transfer to the WCCF fund corpus.

Fiscal Impact

From/To	Acct No.	Description	Amount
---------	----------	-------------	--------

Attachments

No file(s) attached.

Form Review

Inbox

County Judge Exec Asst.
Form Started By: Gary Boyd
Final Approval Date: 02/21/2018

Reviewed By

Wendy Coco

Date

02/21/2018 04:25 PM
Started On: 02/20/2018 12:55 PM

Commissioners Court - Regular Session

40.

Meeting Date: 02/27/2018

County Attorney use of Unallocated funds

Submitted For: D. Hobbs

Submitted By: Stephanie Lloyd, County Attorney

Department: County Attorney

Agenda Category: Regular Agenda Items

Information

Agenda Item

Discuss, consider, and take appropriate action on the use of unallocated funds on the law enforcement scale in the County Attorney's office in the amount of \$3,167.82.

Background

County Attorney's office has an L3.10 vacant position that County Attorney is wanting to move another employee that is currently L3.7 into. Then would move current employee of L3.4 in the L3.7. This would leave our L3.4 vacant and County Attorney would then use \$2,565.68 to post for L3.6 investigator. The TCOLE records County Attorney's office has on file for each of these employees more than warrants the classifications we are requesting.

Fiscal Impact

From/To	Acct No.	Description	Amount
---------	----------	-------------	--------

Attachments

CA-LE Unallocated funds

Form Review

Inbox

County Judge Exec Asst.
Form Started By: Stephanie Lloyd
Final Approval Date: 02/22/2018

Reviewed By

Wendy Coco

Date

02/22/2018 09:27 AM
Started On: 02/21/2018 07:39 PM

Name	PCN	Budget Amount	Requested Amount	Change Amount from Unallocated	Reason for Change	Effective Date
Mark Huard-14342	0051	\$67,394.08			promote employee to PCN 0048	2/23/2018
	0048		\$71,519.24		promote employee to L3.10 based on TCOLE record	2/23/2018
Tom Petkovsek-14413	1801	\$63,506.82			promote employee to PCN 0051	2/23/2018
	0051		\$67,394.08		promote employee to L3.7 based on TCOLE record	2/23/2018
Vacant position	1801	\$63,506.82	\$66,072.50	\$2,565.68	increase vacant position from L3.4 to L3.6 with unallocated funds available	2/23/2018

0049 decreased position L4.12 to L4.10 which caused \$3,167.84 to be left in LE unallocated funds

Remaining LE Unallocated funds \$602.16

Commissioners Court - Regular Session

41.

Meeting Date: 02/27/2018

Supplemental Agreement Expo Center Project

Submitted For: Randy Barker

Submitted By: Melissa Gurka, Purchasing

Department: Purchasing

Agenda Category: Regular Agenda Items

Information

Agenda Item

Discuss, consider, and take appropriate action on approving a Supplemental Agreement to the Agreement for Architectural and Engineering Services, originally procured under RFQ#14RFQ00108, between Populous, Inc. and Williamson County relating to additional architectural and engineering services for construction programming, design and construction administration in the amount of \$233,000 to support the operations of the Williamson County Expo Center and authorizing execution of the agreement.

Background

The additional services are the addition of a horse stall barn, restroom/concessions building on the east side of the existing Expo Hall site and rerouting of the existing water main (if required) to the Williamson County Expo Center Project. This expenditure will be funded from P474 and P475, which were approved as capital requests for FY 2018. Please see agreement for breakdown of expenditures.

Fiscal Impact

From/To	Acct No.	Description	Amount
---------	----------	-------------	--------

Attachments

Supplemental Agreement

Form Review

Inbox

Purchasing (Originator)
County Judge Exec Asst.
Form Started By: Melissa Gurka
Final Approval Date: 02/22/2018

Reviewed By

Randy Barker
Wendy Coco

Date

02/22/2018 11:08 AM
02/22/2018 11:16 AM
Started On: 02/20/2018 03:07 PM

SUPPLEMENTAL AGREEMENT
TO
AGREEMENT FOR ARCHITECTURAL
AND
ENGINEERING SERVICES

WILLIAMSON COUNTY EXPO CENTER PROJECT (“Project”)

This Supplemental Agreement to the Agreement for Architectural and Engineering Services (“Supplemental Agreement”) is by and between Williamson County, Texas, a political subdivision of the State of Texas, (the “County”) and Populous, Inc. (the “A/E”).

RECITALS

WHEREAS, County and A/E entered into an Agreement for Architectural and Engineering Services dated effective as of January 16, 2015 (the “Agreement”) for the provision of professional services in connection with the Williamson County Expo Center (the “Project”); and

WHEREAS, following the A/E’s performance of the Basic Services under the Agreement, County determined a need to add a horse stall barn, restroom/concessions building on the east side of the existing Expo Hall site and reroute the existing water main (if required) to the Project, which would all constitute Additional Services that were not originally a part of the Basic Services under the Agreement and which are sometimes referred to as being Phase III Construction;

WHEREAS, pursuant to Section III of the Agreement, for the performance of Additional Services not specifically described in the Basic Services, County and A/E must execute a contract modification setting forth the scope of the Additional Services, compensation to be paid to A/E for performance of the Additional Service and a schedule for the performance of such services;

WHEREAS, this Supplemental Agreement provides a description of the scope of Additional Services that are necessary, the Additional Services compensation and a schedule for the performance of the Additional Services; and

WHEREAS, it has become necessary to supplement, modify and amend the Agreement in accordance with the Agreement.

AGREEMENT

NOW, THEREFORE, premises considered, the County and the A/E agree that the Agreement is supplemented, amended and modified as follows:

I. Scope of Additional Services

A/E hereby agrees to provide the Additional Services set forth in Exhibit "A", which is attached hereto and incorporated herein.

II. Additional Services Compensation and Reimbursable Expenses

A/E will perform the above described Additional Services for the lump sum amount of \$233,000.00, which consists of and includes the following lump sum Additional Services fee amounts and reimbursable expenses amount:

- A. Additional Services Associated with Horse Barn: *One Hundred and Forty-Four Thousand Dollars (\$144,000)*
- B. Additional Services Associated with East Side Concessions and Restrooms: *Fifty-Nine Thousand Dollars (\$59,000)*
- C. Additional Services Associated with Relocated Water Main (if required): *Ten Thousand Dollars (\$10,000)*
- D. Reimbursable Expenses charged in accordance with the Williamson County Vendor Reimbursement Policy: *Twenty Thousand Dollars (\$20,000).*

In no event will the Additional Services fee amounts and reimbursable expenses exceed the the total lump sum amount set forth above unless the parties otherwise agree to increase such amount pursuant to a written modification to this Supplemental Agreement.

III. Schedule

A/E will commence performance of the Additional Services immediately upon receipt of County's notice to proceed. A project schedule will be completed and agreed upon by the parties prior to commencement of the Additional Services. A/E's fees are based on the following time frames for the design and construction of the Phase III Construction items:

- Schematic Design- Horse Barn only: Two Months.
- Design Development- Horse Barn only: Two Months.
- Construction Documents- Horse Barn, Concessions and Restrooms: Three and Half Months.
- Construction Administration Horse Barn, Concessions and Restrooms: Eight months.

If there is a need to extends the Additional Services beyond the above milestone date, A/E reserves the right to pursue and request additional services compensation.

IV. Terms of Agreement Control and Extent of Supplemental Agreement

All Additional Services described herein will be performed in accordance with the terms and conditions of the Agreement. All other terms of the Agreement and any prior amendments thereto which have not been specifically amended herein shall remain the same and shall continue in full force and effect.

IN WITNESS WHEREOF, the County and the A/E have executed this Supplemental Agreement, in duplicate, to be effective as of the date of the last party's execution below.

A/E:

Populous, Inc.

By: _____

Signature

Printed Name: CHARLES P. SMITH

Title: SENIOR PRINCIPAL

Date: FEBRUARY 20, 2018

COUNTY:

Williamson County, Texas

By: _____

Dan A. Gattis, County Judge

Date: _____, 20____

Exhibit "A"

Scope of Additional Services

THE FOLLOWING SCOPE OF ADDITIONAL SERVICES IS INTENDED TO BE CONSISTENT WITH THE AGREEMENT. TO THE EXTENT THIS SCOPE OF ADDITIONAL SERVICES IS INCONSISTENT WITH THE AGREEMENT, THE AGREEMENT WILL SUPERSEDE THE SCOPE OF ADDITIONAL SERVICES AND WILL BE CONTROLLING.

With Phase III Construction, County intends to enhance an existing facility with development of new components using industry standard "best practices". The project includes but is not limited to programming, data collection and analysis, recommendations regarding the best possible use of the Master Plan, communication with Williamson County, plan development, preparation and design of construction documents, specifications, review cost estimates, development of bidding and contract documents, and administration of construction. The Williamson County Expo Center houses staff dedicated to operations, maintenance, and marketing of the facility to serve a multitude of venues.

A. Phase III Construction Overview:

The Phase III Construction shall consist of the construction of a horse stall barn with an estimated construction cost of \$1.6M, restroom/concessions building with an estimated construction cost of \$787,500 on the east side of the existing Expo Hall site and rerouting of the existing water main (if required).

1. The Horse Barn shall include approximately 200 stalls, fans, lights, PA system and open on four sides. All attempts shall be made to match existing finishes at the existing Expo Hall.
2. East Concession and Restrooms shall be one building including plumbing, fixtures, mechanical, electrical, and structural. This building also requires the extension of the concrete concourse as noted on the Construction Documents issued on September 16, 2015.
3. The existing 8" water line located underneath the existing Covered Penning/ Warm Up building shall be abandoned and rerouted around the facility per the county's direction (if required).

B. Tasks:

1. The Horse Barn shall be designed in accordance with the terms noted in the Agreement for Architectural and Engineering Services dated effective as of January 16, 2015. A/E shall make all attempts to match existing material and finishes.
2. The East Concession and Restrooms shall per Construction Documents issued on September 16, 2015. A new set of construction documents will need to be developed and combined with the Horse Barn facility documents for bidding. A/E shall make all attempts to match existing material and finishes.
3. A new 8" water main shall be designed in accordance with the local jurisdiction's water department requirements. The existing water main shall be abandoned outside the footprint of the existing Covered Penning/ Warm Up building. Whether required to be determined.

Exhibit "A"

Scope of Additional Services

C. Deliverables:

Design Documents for the Horse Barn and Construction Documents for the East Concession and Restrooms in accordance with the Agreement for Architectural and Engineering Services dated effective as of January 16, 2015. The drawings will be issued as one set of documents with no alternates.

D. Phase III Construction Considerations:

Phase III Construction will include consideration of the following:

- Strategic location and construction of a stall barn that is sufficient in size and scope to accommodate / consider the following:
 - Capacity for 200 stalls
 - Electrical capacity to support the needs of 200 stalls
 - Designated space for selling stalls and shavings.
 - Designated, secured space to store shavings
 - Additional wash racks (if deemed necessary)
 - Additional restrooms (if deemed necessary)
 - Flexibility in design and programming to block out wind and rain completely.
- Construction of previously designed Restrooms/Concessions building on the east side of the complex
- Site work and consideration for additional roads, parking, and related infrastructure.

It should also be noted that future expansion capability of this facility is important to include in the design.

In consideration of the compensation provided in the Supplemental Agreement, A/E shall perform the following Scope of Additional Services, based on standard architectural and engineering practices:

The following is the minimum Scope of Additional Services for the Project. It is intended that the scope cover the entire Project from programming through construction administration. Any omissions in scope should be noted to the County. Provide CAD files for County as needed.

E. Scope of Additional Services:

1. Programming

- a. A/E firm/team shall meet with County staff and other entities/groups involved in the project to determine needs (including spatial and development) of building program(s) for projected needs.
- b. Site evaluations to determine the best possible use of the Master Plan.
- c. Prepare preliminary estimate of Furnishings, Fixtures & Equipment (FF&E).
- d. Provide up to one (1) separate presentation to County Project Management
- e. Coordinate with local government bodies, cities, and local utilities in relation to the Project.

Exhibit "A"
Scope of Additional Services

2. Schematic Design Phase

- a. Based on mutually agreed-upon program, prepare Schematic Design Documents for review and approval.
- b. The A/E firm/team shall provide preliminary estimate of construction cost that aligns the County's budget.

3. Design Development Phase

- a. Based on approved Schematic Design documents, A/E firm/team shall prepare Design Development Documents to fix and describe the size and character of the project, including civil, architectural, structural, mechanical, electrical, and any specialty systems and materials that are necessary.
- b. Compliance with all applicable state, federal and local regulations regarding historic structures; archeological or paleontological items of significance; preparation of any status reports required, and any other design service needed to complete this project.
- c. Conformance with the Americans with Disabilities Act and Texas Accessibility Standards.
- d. Provide Design Development submittal for review and approval, provide two (2) full size plan sets and one (1) electronic set. Submittal shall include, as a minimum, any necessary revisions to the master plan, floor plans, elevations, stall barn, furniture and equipment plans. Provide up to one (1) separate presentation to Williamson County Project Management Team to
 1. discuss project timelines and schedule for project deliverables;
 2. discuss possible design criteria based upon mutually agreed upon programming;
and
 3. additional meeting(s) if needed.

4. Construction Document Phase

- a. Provide construction document drawings and specifications including the furniture related FF&E items (including fixed and movable furniture and equipment). Specifications shall include a requirement for the vendor to supply operations and maintenance manuals and on-site training for all mechanical, electrical and HVAC systems.
- b. Prepare 60% drawings for the planned improvements identified in the "Description of Project."
- c. Meet with County staff to review estimate and drawings. A/E and its consultants shall submit drawings for preliminary review by the County staff for constructible and code review.
- d. Prepare 90% & final drawings (two (2) full size plan sets and one (1) electronic plan set with specifications) and meet with County staff to review.
- e. Provide up to one (1) separate presentation to Williamson County Project Management Team. Presentations shall include, but not be limited to, furniture and finish colors and materials, and recommendations for stall systems and configurations.
- f. Present plans to Commissioners Court as necessary and appropriate and answer any relevant questions as necessary
- g. Obtain any necessary approvals from review and permitting authorities, to include local planning & building departments and architectural barriers review (TDLR).

5. Bidding and Contract Phase

- a. Prepare bid documents and assist the County in advertising for bids.
- b. Oversee Pre-Bid Meeting & prepare addendums (as needed).
- c. Review bids and provide written recommendation(s) to staff.
- d. Oversee Pre-Construction Meeting.
- e. Prepare addenda, review prior approval requests.

Exhibit "A"
Scope of Additional Services

- f. Make recommendations on Bids/Proposals received.
- g. Re-design/re-bid of facility if low bid or proposal exceeds Williamson County's construction budget pursuant to Article XXIX of the Agreement.
- h. Assist, at County's request, with drafting and preparing construction contract documents.

6. Construction Administration Phase

- a. Attend pre-construction conference and up to Eight (8) site visits with weekly or biweekly Video Conference or Conference Call for OAC meeting.
- b. Shop drawing and submittal review.
- c. Provide site observations and/or reviews and develop punch list report as required by Williamson County.
- d. Answer Contractor RFI's to resolve field/design issues within five (5) working days.
- e. Prepare supplemental instructions and sketches.
- f. Review contractor Applications for Payment and recommend for approval.
- g. Provide A/E progress reviews (with reports) before cover up (concrete, walls and ceilings).
- h. Provide substantial and final completion reviews (to include Americans with Disabilities (ADA) review and prepare punch lists.
- i. Review, approve, and provide a final report of reviews.
- j. A/E firm/team will provide review, estimates, and support on Proposed Change Orders from contractor.
- k. Submit record drawings updated to show all changes to the work issued by A/E during the course of construction and compile the "as-built" documents in the format received from the Contractor and deliver three (3) full size plan sets, one (1) CAD file set and one (1) PDF set.

Commissioners Court - Regular Session

42.

Meeting Date: 02/27/2018

Amarillo Junior College Training Agreements

Submitted For: Randy Barker

Submitted By: Johnny Grimaldo, Purchasing

Department: Purchasing

Agenda Category: Regular Agenda Items

Information

Agenda Item

Discuss, consider, and take appropriate action on approving the agreements between Amarillo Junior College District and Williamson County for Technical Training (#180001 Air Generative Sweeper; #180002 Telescopic Hydraulic Excavator; and #180003 Asphalt Distributor) in the amount totaling \$13,965.00.

Background

Each agreement fee is for up to Four (4) Students to attend the class: #18001 Air Generative Sweeper training is on or about March 12 to March 15, 2018; #18002 Telescopic Hydraulic Excavator training is on or about April 9 to April 12, 2018; #18003 Asphalt Distributor training is on or about April 23 to April 26, 2018. These expenditures will be charged to 01.0200.0210.004232 which was approved for FY2018.

Fiscal Impact

From/To	Acct No.	Description	Amount
---------	----------	-------------	--------

Attachments

180002 Telescopic Hydraulic Excavator

180001 Air Generative Sweeper

180003 Asphalt Distributor

Form Review

Inbox

Purchasing (Originator)
County Judge Exec Asst.
Form Started By: Johnny Grimaldo
Final Approval Date: 02/22/2018

Reviewed By

Randy Barker
Wendy Coco

Date

02/22/2018 11:12 AM
02/22/2018 11:16 AM
Started On: 02/21/2018 01:38 PM



Amarillo College

**Technical
Education
Division**

**Williamson County
Training Agreement
#180002
Telescopic Hydraulic
Excavator**

**AGREEMENT with Amarillo Junior College District
Through the Technical Education Division
PO Box 447 Amarillo, TX 79178-0001**

January 23, 2018

The Amarillo Junior College District, a political subdivision of the State of Texas commonly referred to as Amarillo College, through its Technical Education Division, hereinafter referred to as "**College**", and Williamson County, 710 South Main Street, Georgetown, TX 78626, hereinafter referred to as "**Client**" enter into this agreement as follows:

- 1.0 **Purpose:** The **College** shall provide one (1) 32 hour Telescopic Hydraulic Excavator class for certain employees of the **Client** as provided in this agreement:
- 2.0 **Instructional Quality:** The **College** will employ qualified personnel to provide educational services in accordance with state regulations and policies of the **College**. Instructional content of all services will be designed with mutual consent of both parties prior to delivery of any training.
- 3.0 **Term:** The **College** will conduct the Telescopic Hydraulic Excavator training on or about the following schedule:

April 9 to April 12, 2018

Time: 8:00am to 5:00pm with one hour for lunch.
- 4.0 **Fee:** The fee for this training (including travel) is \$4655.00. Four (4) students may attend each class for this price.
- 4.1 **Billing Procedure:** The **College** will invoice the **Client** within thirty (30) working days of the completion of training. Invoice is due and payable *net 30 days*. Payment for services shall be governed by Chapter 2251 of the Texas Government Code.
- 5.0 **Instructional Materials and Supplies:** Instructional materials and supplies will be provided by the **College**. Required instructional equipment will be furnished by the **Client**.



Amarillo College

**Technical
Education
Division**

**Williamson County
Training Agreement
#180002
Telescopic Hydraulic
Excavator**

AGREEMENT between Amarillo College and Williamson County, continued page 2.

- 5.1 **Copying:** No portion of the services provided herein shall be copied or reproduced in any form without prior consent of the **College** and **Client**.
- 5.2 **Videotaping:** No portion of the services provided herein shall be videotaped without the prior consent of the **College** and **Client**.
- 6.0 **Facilities/Equipment:** The training will be conducted at facilities of the **Client**. Telescopic Hydraulic Excavators provided by the **Client**.
- 7.0 **Amendment:** This agreement may be changed in writing to notify or extend the stated terms by mutual consent of the parties herein.
- 7.1 **Termination for Convenience:** This agreement may be terminated at any time at the option of either party, without future or prospective liability for the performance upon giving (30) days written notice thereof. In the event of termination, the **Client** will only be liable for its pro rata share of services rendered and services actually received.
- 7.2 **Assignment:** The **College** shall not assign this agreement without the written consent of the **Client**.
- 7.3 **Force Majeure:** Neither the **College** nor the **Client** shall be responsible for any delays in performance of this agreement due to strike, riots, acts of God, war, governmental laws or regulations. If a delay occurs, the **College** and the **Client** will make a good faith effort to reschedule the service.
- 7.4 **Indemnity:** TO THE EXTENT ALLOWED BY LAW (a) **Client**, in consideration of the training described above, hereby releases, waives, discharges and covenants not to sue the **College**, its officers and employees, and (b) agrees to indemnify and save and hold harmless the **College**, its officers, and employees from any loss, liability, damage, or cost and all claims for damages, personal or otherwise, arising while the **Client** is performing this agreement, whether caused by a member of the **Client** or by any other persons, without regard to whether the damage, personal or otherwise, is brought about or caused by negligence, whether on the part of the **Client** or the **College** or the **College's** employees.



Amarillo College

**Technical
Education
Division**

**Williamson County
Training Agreement
#180002
Telescopic Hydraulic
Excavator**

AGREEMENT between Amarillo College and Williamson County, continued page 3.

- 7.5 **No Waiver of Sovereign Immunity or Powers:** Nothing in this agreement will be deemed to constitute a waiver of sovereign immunity or powers of the **College** or the **Client**.
- 7.6 **Right to Audit:** The **College** agrees to provide the **Client** or its duly authorized representative access to and the right to examine any and all books, documents, papers and records of the **College** which are directly pertinent to the services to be performed under this agreement. The **College** has the authority to protect the records of students from unauthorized disclosure under the Family Educational Rights and Privacy Act.
- 7.7 **Mediation:** The parties agree to use mediation for dispute resolution prior to and formal legal action being taken on this agreement.
- 7.8 **Enrollment Eligibility Notice:** Students with outstanding obligations to Amarillo College will receive written notification and may not be allowed to enroll in or complete a continuing education course until the obligations are fulfilled.
- 7.9 **Venue:** This agreement shall be construed under and in accordance with the laws of the State of Texas, and all obligations of the parties created hereunder are performable in Potter County, Texas.
- 8.0 **Notice:** Any notice provided under this agreement shall be delivered by mail or personal service to the parties named below.

Client Representative

The Honorable Dan A. Gattis
Williamson County Judge
710 South Main Street
Suite 101
Georgetown, TX 78626

By: _____

Date: _____

College Representative

Steve Smith
VP Business Affairs
Amarillo College

By:  _____

Date: 1-25-2018



Amarillo College

**Technical
Education
Division**

**Williamson County
Training Agreement
#180001
Air Generative Sweeper**

**AGREEMENT with Amarillo Junior College District
Through the Technical Education Division
PO Box 447 Amarillo, TX 79178-0001**

January 23, 2018

The Amarillo Junior College District, a political subdivision of the State of Texas commonly referred to as Amarillo College, through its Technical Education Division, hereinafter referred to as "**College**", and Williamson County, 710 South Main Street, Georgetown, TX 78626, hereinafter referred to as "**Client**" enter into this agreement as follows:

- 1.0 **Purpose:** The **College** shall provide one (1) 32 hour Air Generative Sweeper class for certain employees of the **Client** as provided in this agreement:
- 2.0 **Instructional Quality:** The **College** will employ qualified personnel to provide educational services in accordance with state regulations and policies of the **College**. Instructional content of all services will be designed with mutual consent of both parties prior to delivery of any training.
- 3.0 **Term:** The **College** will conduct the Air Generative Sweeper training on or about the following schedule:

March 12 to March 15, 2018

Time: 8:00am to 5:00pm with one hour for lunch.
- 4.0 **Fee:** The fee for this training (including travel) is \$4655.00. Four (4) students may attend each class for this price.
- 4.1 **Billing Procedure:** The **College** will invoice the **Client** within thirty (30) working days of the completion of training. Invoice is due and payable *net 30 days*. Payment for services shall be governed by Chapter 2251 of the Texas Government Code.
- 5.0 **Instructional Materials and Supplies:** Instructional materials and supplies will be provided by the **College**. Required instructional equipment will be furnished by the **Client**.



Amarillo College

**Technical
Education
Division**

**Williamson County
Training Agreement
#180001
Air Generative Sweeper**

AGREEMENT between Amarillo College and Williamson County, continued page 2.

- 5.1 **Copying:** No portion of the services provided herein shall be copied or reproduced in any form without prior consent of the **College** and **Client**.
- 5.2 **Videotaping:** No portion of the services provided herein shall be videotaped without the prior consent of the **College** and **Client**.
- 6.0 **Facilities/Equipment:** The training will be conducted at facilities of the **Client**. Air Generative Sweepers provided by the **Client**.
- 7.0 **Amendment:** This agreement may be changed in writing to notify or extend the stated terms by mutual consent of the parties herein.
- 7.1 **Termination for Convenience:** This agreement may be terminated at any time at the option of either party, without future or prospective liability for the performance upon giving (30) days written notice thereof. In the event of termination, the **Client** will only be liable for its pro rata share of services rendered and services actually received.
- 7.2 **Assignment:** The **College** shall not assign this agreement without the written consent of the **Client**.
- 7.3 **Force Majeure:** Neither the **College** nor the **Client** shall be responsible for any delays in performance of this agreement due to strike, riots, acts of God, war, governmental laws or regulations. If a delay occurs, the **College** and the **Client** will make a good faith effort to reschedule the service.
- 7.4 **Indemnity:** TO THE EXTENT ALLOWED BY LAW (a) **Client**, in consideration of the training described above, hereby releases, waives, discharges and covenants not to sue the **College**, its officers and employees, and (b) agrees to indemnify and save and hold harmless the **College**, its officers, and employees from any loss, liability, damage, or cost and all claims for damages, personal or otherwise, arising while the **Client** is performing this agreement, whether caused by a member of the **Client** or by any other persons, without regard to whether the damage, personal or otherwise, is brought about or caused by negligence, whether on the part of the **Client** or the **College** or the **College's** employees.



Amarillo College

**Technical
Education
Division**

**Williamson County
Training Agreement
#180001
Air Generative Sweeper**

AGREEMENT between Amarillo College and Williamson County, continued page 3.

- 7.5 **No Waiver of Sovereign Immunity or Powers:** Nothing in this agreement will be deemed to constitute a waiver of sovereign immunity or powers of the **College** or the **Client**.
- 7.6 **Right to Audit:** The **College** agrees to provide the **Client** or its duly authorized representative access to and the right to examine any and all books, documents, papers and records of the **College** which are directly pertinent to the services to be performed under this agreement. The **College** has the authority to protect the records of students from unauthorized disclosure under the Family Educational Rights and Privacy Act.
- 7.7 **Mediation:** The parties agree to use mediation for dispute resolution prior to and formal legal action being taken on this agreement.
- 7.8 **Enrollment Eligibility Notice:** Students with outstanding obligations to Amarillo College will receive written notification and may not be allowed to enroll in or complete a continuing education course until the obligations are fulfilled.
- 7.9 **Venue:** This agreement shall be construed under and in accordance with the laws of the State of Texas, and all obligations of the parties created hereunder are performable in Potter County, Texas.
- 8.0 **Notice:** Any notice provided under this agreement shall be delivered by mail or personal service to the parties named below.

Client Representative

The Honorable Dan A. Gattis
Williamson County Judge
710 South Main Street
Suite 101
Georgetown, TX 78626

By: _____

Date: _____

College Representative

Steve Smith
VP Business Affairs
Amarillo College

By:  _____

Date: 1/25/2018



Amarillo College

**Technical
Education
Division**

**Williamson County
Training Agreement
#180003
Asphalt Distributor**

**AGREEMENT with Amarillo Junior College District
Through the Technical Education Division
PO Box 447 Amarillo, TX 79178-0001**

January 23, 2018

The Amarillo Junior College District, a political subdivision of the State of Texas commonly referred to as Amarillo College, through its Technical Education Division, hereinafter referred to as "**College**", and Williamson County, 710 South Main Street, Georgetown, TX 78626, hereinafter referred to as "**Client**" enter into this agreement as follows:

- 1.0 **Purpose:** The **College** shall provide one (1) 32 hour Asphalt Distributor class for certain employees of the **Client** as provided in this agreement:
- 2.0 **Instructional Quality:** The **College** will employ qualified personnel to provide educational services in accordance with state regulations and policies of the **College**. Instructional content of all services will be designed with mutual consent of both parties prior to delivery of any training.
- 3.0 **Term:** The **College** will conduct the Asphalt Distributor training on or about the following schedule:

April 23 to April 26, 2018

Time: 8:00am to 5:00pm with one hour for lunch.
- 4.0 **Fee:** The fee for this training (including travel) is \$4655.00. Four (4) students may attend each class for this price.
- 4.1 **Billing Procedure:** The **College** will invoice the **Client** within thirty (30) working days of the completion of training. Invoice is due and payable *net 30 days*. Payment for services shall be governed by Chapter 2251 of the Texas Government Code.
- 5.0 **Instructional Materials and Supplies:** Instructional materials and supplies will be provided by the **College**. Required instructional equipment will be furnished by the **Client**.



Amarillo College

**Technical
Education
Division**

**Williamson County
Training Agreement
#180003
Asphalt Distributor**

AGREEMENT between Amarillo College and Williamson County, continued page 2.

- 5.1 **Copying:** No portion of the services provided herein shall be copied or reproduced in any form without prior consent of the **College** and **Client**.
- 5.2 **Videotaping:** No portion of the services provided herein shall be videotaped without the prior consent of the **College** and **Client**.
- 6.0 **Facilities/Equipment:** The training will be conducted at facilities of the **Client**. Asphalt Distributors provided by the **Client**.
- 7.0 **Amendment:** This agreement may be changed in writing to notify or extend the stated terms by mutual consent of the parties herein.
- 7.1 **Termination for Convenience:** This agreement may be terminated at any time at the option of either party, without future or prospective liability for the performance upon giving (30) days written notice thereof. In the event of termination, the **Client** will only be liable for its pro rata share of services rendered and services actually received.
- 7.2 **Assignment:** The **College** shall not assign this agreement without the written consent of the **Client**.
- 7.3 **Force Majeure:** Neither the **College** nor the **Client** shall be responsible for any delays in performance of this agreement due to strike, riots, acts of God, war, governmental laws or regulations. If a delay occurs, the **College** and the **Client** will make a good faith effort to reschedule the service.
- 7.4 **Indemnity:** TO THE EXTENT ALLOWED BY LAW (a) **Client**, in consideration of the training described above, hereby releases, waives, discharges and covenants not to sue the **College**, its officers and employees, and (b) agrees to indemnify and save and hold harmless the **College**, its officers, and employees from any loss, liability, damage, or cost and all claims for damages, personal or otherwise, arising while the **Client** is performing this agreement, whether caused by a member of the **Client** or by any other persons, without regard to whether the damage, personal or otherwise, is brought about or caused by negligence, whether on the part of the **Client** or the **College** or the **College's** employees.



Amarillo College

**Technical
Education
Division**

**Williamson County
Training Agreement
#180003
Asphalt Distributor**

AGREEMENT between Amarillo College and Williamson County, continued page 3.

- 7.5 **No Waiver of Sovereign Immunity or Powers:** Nothing in this agreement will be deemed to constitute a waiver of sovereign immunity or powers of the **College** or the **Client**.
- 7.6 **Right to Audit:** The **College** agrees to provide the **Client** or its duly authorized representative access to and the right to examine any and all books, documents, papers and records of the **College** which are directly pertinent to the services to be performed under this agreement. The **College** has the authority to protect the records of students from unauthorized disclosure under the Family Educational Rights and Privacy Act.
- 7.7 **Mediation:** The parties agree to use mediation for dispute resolution prior to and formal legal action being taken on this agreement.
- 7.8 **Enrollment Eligibility Notice:** Students with outstanding obligations to Amarillo College will receive written notification and may not be allowed to enroll in or complete a continuing education course until the obligations are fulfilled.
- 7.9 **Venue:** This agreement shall be construed under and in accordance with the laws of the State of Texas, and all obligations of the parties created hereunder are performable in Potter County, Texas.
- 8.0 **Notice:** Any notice provided under this agreement shall be delivered by mail or personal service to the parties named below.

Client Representative

The Honorable Dan A. Gattis
Williamson County Judge
710 South Main Street
Suite 101
Georgetown, TX 78626

By: _____

Date: _____

College Representative

Steve Smith
VP Business Affairs
Amarillo College

By:  _____

Date: 1-25-2018

Commissioners Court - Regular Session

43.

Meeting Date: 02/27/2018

SO gym equipment

Submitted By: Kerstin Hancock, Purchasing

Department: Purchasing

Agenda Category: Regular Agenda Items

Information

Agenda Item

Discuss, consider, and take appropriate action on approving purchase of gym equipment from Marathon Fitness for the new Sheriff's Office Training Facility in the amount of \$101,143.68, pursuant to BuyBoard contract # 502-16.

Background

This is for gym equipment for the new Sheriff's Office Training Facility.

Fiscal Impact

From/To	Acct No.	Description	Amount
---------	----------	-------------	--------

Attachments

[Marathon Fitness quote](#)

Form Review

Inbox

Purchasing (Originator)
County Judge Exec Asst.
Form Started By: Kerstin Hancock
Final Approval Date: 02/22/2018

Reviewed By

Randy Barker
Wendy Coco

Date

02/22/2018 10:30 AM
02/22/2018 11:03 AM
Started On: 02/22/2018 08:44 AM



Marathon Fitness

www.MarathonFitness.com
 P.O. Box 17705
 Sugar Land, TX 77496
 Tel:(800) 391-9496 Fax:(888) 240-9360

Sales Proposal

Date Nov 14, 2017	Page Page 3 of 6
Proposal Number QT0013075	

Marathon Fitness™

Fitness Center Specialists

Bill To:

Williamson County Sheriff's Office
 Training Division
 107 Holly Street
 Georgetown, TX 78626

Ship To:

Williamson County Sheriff's Office
 Training Division
 107 Holly Street
 Georgetown, TX 78626

Salesperson Demariee Anderson	Proposal Valid Until 1/13/2018	Terms Net 30
---	--	------------------------

Qty.	Item Number	Description	Unit Retail	Sales Price	Extended Price
1	GCT-R	Troy Chinning Triangle with Rubber Grip	\$ 36.00	\$ 30.60	\$ 30.60
1	ATR-36	Troy Tricep rope w/solid rubber ends - black.	\$ 40.00	\$ 34.00	\$ 34.00
1	GCB-28SR	Troy 28" Economy Curl Bar W/ Swivel And Rubber Grips	\$ 46.00	\$ 39.10	\$ 39.10
1	MISC	Troy Revolving Stirrup Handle w/ Rubber Grip Solid (TCCH-R)	\$ 46.00	\$ 39.10	\$ 39.10
1	GOB-1800	Troy 7' Olympic Lift Bar. 7 foot 44lb 1200lb test 220,000 psi	\$ 277.00	\$ 235.45	\$ 235.45
2	CKB-010	Troy VTX Rubber Kettlebell 10lb	\$ 26.00	\$ 22.10	\$ 44.20
2	CKB-020	Troy VTX Rubber Kettlebell 20lb	\$ 52.00	\$ 44.20	\$ 88.40
2	CKB-030	Troy VTX Rubber Kettlebell 30lb	\$ 78.00	\$ 66.30	\$ 132.60
2	CKB-040	Troy VTX Rubber Kettlebell 40lb	\$ 104.00	\$ 88.40	\$ 176.80
2	CKB-050	Troy VTX Rubber Kettlebell 50lb	\$ 130.00	\$ 110.50	\$ 221.00
1	MISC EQUIPMENT	Troy Custom LOGO on Free Weights Troy Custom LOGO on Dumbbells, Plates, Barbells. NOTE: 12 Week Lead Time for Custom Logo. Lead Times will vary depending on when order is placed.	\$ 2,500.00	\$ 2,500.00	\$ 2,500.00
1	FREIGHT	Freight	\$ 5,550.00	\$ 5,550.00	\$ 5,550.00
1	EQUIP INSTALL	Equipment Installation	\$ 1,675.00	\$ 1,675.00	\$ 1,675.00
	NOTE	Functional Training System FRAME			
8	OCF001	Escape Frame Leg Type 1	\$ 775.00	\$ 620.00	\$ 4,960.00
2	OCF102	Escape Cross Beam - Short	\$ 190.00	\$ 152.00	\$ 304.00

Quotation continued on next page ...





Marathon Fitness

www.MarathonFitness.com
 P.O. Box 17705
 Sugar Land, TX 77496
 Tel:(800) 391-9496 Fax:(888) 240-9360

Sales Proposal

Date Nov 14, 2017	Page Page 4 of 6
Proposal Number QT0013075	

Marathon Fitness™

Fitness Center Specialists

Bill To:

Williamson County Sheriff's Office
 Training Division
 107 Holly Street
 Georgetown, TX 78626

Ship To:

Williamson County Sheriff's Office
 Training Division
 107 Holly Street
 Georgetown, TX 78626

Salesperson	Proposal Valid Until	Terms
Demariee Anderson	1/13/2018	Net 30

Qty.	Item Number	Description	Unit Retail	Sales Price	Extended Price
4	OCF103	Escape Cross Beam Angle	\$ 215.00	\$ 172.00	\$ 688.00
2	OCF104	Escape Cross Beam - Long	\$ 375.00	\$ 300.00	\$ 600.00
1	OCA006	Escape Wing Attachment Short	\$ 680.00	\$ 544.00	\$ 544.00
6	OCA001	Escape Monkey Bars (Each)	\$ 255.00	\$ 204.00	\$ 1,224.00
2	OCA019	Escape Catch Rack Set Pair	\$ 730.00	\$ 584.00	\$ 1,168.00
4	OCA018	Escape Adjuster Teeth	\$ 295.00	\$ 236.00	\$ 944.00
2	OCA053	Escape Extended Catch Rack Pair Standard	\$ 775.00	\$ 620.00	\$ 1,240.00
4	OCA002	Escape Weight Horn	\$ 215.00	\$ 172.00	\$ 688.00
2	OCA003	Escape Battle Rope Eye	\$ 130.00	\$ 104.00	\$ 208.00
2	OCA004	Escape Torso Trainer	\$ 635.00	\$ 508.00	\$ 1,016.00
2	OCA016	Escape Fixed Dip Station	\$ 505.00	\$ 404.00	\$ 808.00
1	OCA005	Escape Raised Pull up Bar	\$ 225.00	\$ 180.00	\$ 180.00
2	OCA012	Escape Rope Pulley Mount Arm	\$ 305.00	\$ 244.00	\$ 488.00
2	OCA015	Escape Rope Pulley Unit (Excludes Mounting Arm)	\$ 2,825.00	\$ 2,260.00	\$ 4,520.00
1	OCA051	Escape Probounder unit Octagon	\$ 495.00	\$ 396.00	\$ 396.00
1	OCA052	Escape Probounder Short Adjuster Rail	\$ 105.00	\$ 84.00	\$ 84.00
1	OCE017	Escape Octagon Leg Mount Target	\$ 620.00	\$ 496.00	\$ 496.00
1	OCE027	Escape Octagon Anchor Kit 8 Leg	\$ 73.10	\$ 73.10	\$ 73.10
1	OCE011	Escape Tool Kit	\$ 130.00	\$ 130.00	\$ 130.00
1	OCTBOLT	Escape Bolt Pack	\$ 68.00	\$ 68.00	\$ 68.00

Quotation continued on next page ...





Marathon Fitness

www.MarathonFitness.com
 P.O. Box 17705
 Sugar Land, TX 77496
 Tel:(800) 391-9496 Fax:(888) 240-9360

Sales Proposal

Date Nov 14, 2017	Page Page 5 of 6
Proposal Number QT0013075	

Marathon Fitness™

Fitness Center Specialists

Bill To:

Williamson County Sheriff's Office
 Training Division
 107 Holly Street
 Georgetown, TX 78626

Ship To:

Williamson County Sheriff's Office
 Training Division
 107 Holly Street
 Georgetown, TX 78626

Salesperson	Proposal Valid Until	Terms
Demarree Anderson	1/13/2018	Net 30

Qty.	Item Number	Description	Unit Retail	Sales Price	Extended Price
	NOTE	Attachments			
2	BR3210	Escape Battle Rope 32mm (1.5") (32' Length) Black (Not Covered)	\$ 290.00	\$ 232.00	\$ 464.00
2	TRXCLUB4	Commercial Suspension Trainer v.4(rubber handles, locking carabiner)	\$ 209.95	\$ 178.46	\$ 356.91
1	WBANDS	Escape Power Band Small - Green	\$ 20.50	\$ 16.40	\$ 16.40
1	WBANDM	Escape Power Band Medium - Blue	\$ 31.00	\$ 24.80	\$ 24.80
1	WBANDL	Escape Power Band Large - Red	\$ 41.00	\$ 32.80	\$ 32.80
1	FREIGHT	Freight	\$ 2,000.00	\$ 2,000.00	\$ 2,000.00
1	EQUIP INSTALL	Equipment Installation	\$ 2,250.00	\$ 2,250.00	\$ 2,250.00
	NOTE	Above Installation rate includes anchoring the above Escape Octagon frame to the floor per the manufacturer's requirements. This service will be provided through Marathon Fitness.			
		Escape Frame Lead Time 9-10 Weeks Escape Frame Lead times vary depending on when order is placed.			

Quotation continued on next page ...





Marathon Fitness™

Fitness Center Specialists

Marathon Fitness

www.MarathonFitness.com
 P.O. Box 17705
 Sugar Land, TX 77496
 Tel:(800) 391-9496 Fax:(888) 240-9360

Sales Proposal

Date Nov 14, 2017	Page Page 6 of 6
Proposal Number QT0013075	

Bill To:

Williamson County Sheriff's Office
 Training Division
 107 Holly Street
 Georgetown, TX 78626

Ship To:

Williamson County Sheriff's Office
 Training Division
 107 Holly Street
 Georgetown, TX 78626

Salesperson Demariee Anderson	Proposal Valid Until 1/13/2018	Terms Net 30
---	--	------------------------

Qty.	Item Number	Description	Unit Retail	Sales Price	Extended Price
	BUY BOARD NOTE	BUY BOARD INFORMATION Vendor: Team Marathon Fitness, Address: PO Box 17705, Sugar Land, TX 77496 Phone: (281) 565-2307, Contact: Paul Croegaert, Email: paul@marathonfitness.com Federal ID: 68-05446644, Contract: Athletic, PE & Gym, Supplies H.D. Exercise Eq. & Accessories #502-16, Effective Date: 4/1/2016 **Items Open Market			

I accept the terms and conditions of this proposal. Prices are valid for 30 days. Equipment remains the property of Marathon Fitness until paid in full.
 Mastercard, American Express, or VISA are accepted and subject to a 3% convenience fee.

Signature: _____ PO# _____
 Printed Name: _____ Title: _____

DELIVERY INSTRUCTIONS:

Must arrive by ___ / ___ / _____ Loading Dock: Yes ___ No ___
 Elevator: Yes ___ No ___

Subtotal	\$ 101,143.68
Sales Tax 0.00%	\$ 0.00
Total	\$ 101,143.68



Commissioners Court - Regular Session

44.

Meeting Date: 02/27/2018

Gym equipment for the SO training center

Submitted By: Kerstin Hancock, Purchasing

Department: Purchasing

Agenda Category: Regular Agenda Items

Information

Agenda Item

Discuss, consider, and take appropriate action on approving purchase of gym equipment for the new Sheriff's Office Training Facility from Fringe Sport in the amount of \$3,821.37, and asking the Commissioners Court to waive the three (3) quote requirement as required by the Williamson County Purchasing Policy.

Background

Please see attached quote for details. The Williamson County Purchasing Policy as approved by the Commissioners' Court requires three (3) written quotes for purchases exceeding \$2,000; this purchase would be made as an exception to that policy.

Fiscal Impact

From/To	Acct No.	Description	Amount
---------	----------	-------------	--------

Attachments

Fringe Sport quote

Form Review

Inbox

Purchasing (Originator)
County Judge Exec Asst.
Form Started By: Kerstin Hancock
Final Approval Date: 02/22/2018

Reviewed By

Randy Barker
Wendy Coco

Date

02/22/2018 10:36 AM
02/22/2018 11:03 AM
Started On: 02/22/2018 09:08 AM



Quote #: 86880

08 Nov 2017

Customer:

Company: Williamson County Sheriff Office

Ship To:

AARON SKINNER
WILLIAMSON COUNTY SHERIFF OFFICE
UNITED STATES

Bill To:

Aaron Skinner

Qty	Item name	SKU	Item Price	Item Total
2.0000	OneFitWonder Power Rack with Wall Ball Target » 1 x Power Rack with Wall Ball Target - Box 1 of 4 » 1 x Power Rack with Wall Ball Target - Box 2 of 4 » 1 x Power Rack with Wall Ball Target - Box 3 of 4 » 1 x Power Rack with Wall Ball Target - Box 4 of 4	Rack-OFW-PowerWithBall	\$509.1500	\$1,018.30
1	OneFitWonder Commercial Chariot Sled <i>Title: 1 Used: NEW</i>	OFW-CSLED	\$237.1500	\$237.15
2	OneFitWonder Wonder Bar Barbell 20kg (Bushing)	Bar-OFW-WonderBar-Bushing-20	\$152.2350	\$304.47
3.0000	OneFitWonder Black Bumper Plate Sets <i>Choose Your Set:: 10/25/45 Entry Level - \$269</i> » 1 x OneFitWonder Black Bumper Plates (Pairs) <i>Size:10lbUsed:NEW</i> » 1 x OneFitWonder Black Bumper Plates (Pairs) <i>Size:25lbUsed:NEW</i> » 1 x OneFitWonder Black Bumper Plates (Pairs) <i>Size:45LbUsed:NEW</i>	OFW-BPEL	\$245.6500	\$736.95
10	Premium Molded Foam Roller <i>Size: 18 inch</i>	PMFR186	\$21.2500	\$212.50
2	OneFitWonder Sisal Climbing Rope <i>Title: 1 Used: NEW</i>	OFW-SCR23	\$92.6500	\$185.30
3	OneFitWonder Multi-Sided Plyo Boxes	Plyo-OFW-LgMulti-FLAT	\$114.7500	\$344.25
1	OneFitWonder V4 Medicine Ball	MB-OFW-V4-16lb	\$67.1500	\$67.15
1	OneFitWonder V4 Medicine Ball	MB-OFW-V4-20lb	\$72.2500	\$72.25
1	OneFitWonder V4 Medicine Ball	MB-OFW-V4-30lb	\$89.2500	\$89.25
1	OneFitWonder V4 Medicine Ball	MB-OFW-V4-24lb	\$89.0000	\$89.00
1	OneFitWonder V4 Medicine Ball	MB-OFW-V4-14lb	\$63.7500	\$63.75
1	OneFitWonder V4 Medicine Ball	MB-OFW-V4-12lb	\$58.6500	\$58.65
1	OneFitWonder V4 Medicine Ball	MB-OFW-V4-10lb	\$55.2500	\$55.25
3.0000	Exercise ball		\$7.9700	\$23.91

Qty	Item name	SKU	Item Price	Item Total
1.0000	storage rack for body ball		\$45.6400	\$45.64
4	OneFitWonder Sandbag Trainer (come empty unless request with sand) Size: LXL	OFW-SBT-L	\$33.1500	\$132.60
10	OneFitWonder Cable Speed Rope Color: Black Quantity: 1	OFW-CSRBI	\$8.5000	\$85.00
Subtotal				\$3,821.37
Non Taxable @ 0%				\$0.00
Total				\$3,821.37
Paid to date				\$0.00

3725 Drossett Drive, Austin, TX 78744
sales@fringesport.com | (512) 201-4404

Commissioners Court - Regular Session

45.

Meeting Date: 02/27/2018

Ice maker for SO training facility

Submitted By: Kerstin Hancock, Purchasing

Department: Purchasing

Agenda Category: Regular Agenda Items

Information

Agenda Item

Discuss, consider, and take appropriate action on approving purchase of Ice Maker from LoneStar Restaurant Supply for the new Sheriff's Office Training Facility, in the amount of \$2,569.00, and asking the Commissioners Court to waive the three (3) quote requirement as required by the Williamson County Purchasing Policy.

Background

Please see attached quote for details. The Williamson County Purchasing Policy as approved by Commissioners' Court requires three (3) written quotes for purchases in excess of \$2,000; this purchase would be an exception to that policy.

Fiscal Impact

From/To	Acct No.	Description	Amount
---------	----------	-------------	--------

Attachments

[Lonestar quote](#)

Form Review

Inbox

Purchasing (Originator)
County Judge Exec Asst.
Form Started By: Kerstin Hancock
Final Approval Date: 02/22/2018

Reviewed By

Randy Barker
Wendy Coco

Date

02/22/2018 10:39 AM
02/22/2018 11:03 AM
Started On: 02/22/2018 09:18 AM

LoneStar Restaurant Supply
 8131 North IH 35
 Austin, TX 78753
 (512) 467-6777

Sales Order

*Scotsman
 w/3 Stage Filter*

1014

Date
 9/24/2015

Bill To

Sheri, Williamson County -
 508 South Rock St.
 Georgetown, TX 78626

Ship To

P.O. Number Terms Rep
 158203

Item Code	Description	Quantity	U/M	Price Each	MPN	Amount
CU3030SA-1	Ice Maker Cube 110 lb Bin Undercounter Serial Number: 14101320016180	1	ea	2,335.00	CU3030SA	2,335.00
AP1-1	Filter Water Ice Maker	1	ea	149.00	-1 AP1-1	149.00
DFSMLNC	Local delivery	1	ea	85.00	DFSMLNC	85.00

*Scotsman
 30" wide
 28 1/2" Deep
 39 1/2" Tall*

*Received
 9/24/15
 Nancy
 Dennis*

*JG1551
 AquaPatrol
 APRC1-P RECORDED*

All orders of equipment and other products ("Equipment") from LoneStar Restaurant Supply ("Seller") are subject to Terms and Conditions of sale. Only manufacturer's warranties apply to new Equipment sales. For returns, prior authorization is required, less than 90 days from invoice date, shipped prepaid freight, 30% restocking and recertification charge plus cost of repairs if damaged. Equipment will be installed by the Customer. Seller shall in no event be liable for damages, including without limitation incidental or consequential damages, to any property or to any person in connection with the sale, delivery, installation or use of the Equipment, and Customer shall indemnify and hold harmless Seller against all such liability.

Subtotal \$2,569.00
 Sales Tax (0.0%) \$0.00
Total \$2,569.00

Commissioners Court - Regular Session

46.

Meeting Date: 02/27/2018

RFP 1771-204 Quality Assurance Evaluation for Emergency Communications

Submitted For: Randy Barker

Submitted By: Johnny Grimaldo, Purchasing

Department: Purchasing

Agenda Category: Regular Agenda Items

Information

Agenda Item

Discuss, consider, and take appropriate action on awarding RFP# 1771-204, for Quality Assurance Evaluation for Emergency Communication Radio Traffic Services, to the only proposal, The Denise Amber Lee Foundation, INC and authorizing the execution of the agreement.

Background

Williamson County received two (2) offers; One (1) was responsive and one (1) was a no-bid. The solicitation was review by 36 suppliers. There are very few providers of this service. Radio QA is a highly specialized function and requires a highly technical workforce. Although there are numerous individuals and consultants that can provide ad hoc services, there are only a select few companies, agencies, and academies that have the capability of providing this service at the scale we are seeking. The evaluation team’s recommendation: The Denise Amber Lee Foundation (DALF) has a reputation and the resources to provide the team needed for this type review. DALF is dedicated to the improvement of 9-1-1 services, through education and quality improvement processes, across the United States. DALF was instrumental in the education and oversight of the initial implementation of our Quality Assurance/Quality Improvement program and demonstrated the ability to bring in quality materials, personnel, and work products. This was reflected in their submission. This is a one-time purchase. This expenditure will be charged to 0100.0581.004500 and is authorized at a not to exceed amount of \$80,000 in the FY2018 budget.

Fiscal Impact

From/To	Acct No.	Description	Amount
---------	----------	-------------	--------

Attachments

[DALF Service Contract score sheet](#)

Form Review

Inbox	Reviewed By	Date
Purchasing (Originator)	Kerstin Hancock	02/22/2018 10:16 AM
Purchasing (Originator)	Randy Barker	02/22/2018 11:54 AM
County Judge Exec Asst.	Wendy Coco	02/22/2018 01:02 PM
Form Started By: Johnny Grimaldo		Started On: 02/22/2018 09:24 AM
Final Approval Date: 02/22/2018		

THE STATE OF TEXAS §

COUNTY OF WILLIAMSON §

SERVICES CONTRACT
RFP #1771-204
(Quality Assurance Evaluation for
Emergency Communications Radio
Traffic)

THIS CONTRACT is made and entered into by and between **Williamson County, Texas** (hereinafter "The County"), a political subdivision of the State of Texas, acting herein by and through its governing body, and **The Denise Amber Lee Foundation, Inc.**, (hereinafter "DALF"), a foreign non-profit corporation with corporate office in the State of Florida, **19503 S. West Villages Pkwy, Ste. A-8, Venice, FL 34295** (Phone 941-830-2035). The County agrees to engage DALF as an independent contractor, to assist in providing certain operational services pursuant to the following terms, conditions, and restrictions:

I.

No Agency Relationship & Indemnification: It is understood and agreed that DALF shall not in any sense be considered a partner or joint venturer with The County, nor shall DALF hold itself out as an agent or official representative of The County unless expressly authorized to do so by a majority of the Williamson County Commissioners Court. DALF shall be considered an independent contractor for the purpose of this agreement and shall in no manner incur any expense or liability on behalf of The County other than what may be expressly allowed under this agreement. The County will not be liable for any loss, cost, expense or damage, whether indirect, incidental, punitive, exemplary, consequential of any kind whatsoever for any acts by DALF or failure to act relating to the services being provided. DALF agrees to indemnify, hold harmless, and defend The County against any claim, demand, loss, injury, damages, action, or liability of any kind against The County resulting from any services DALF perform on behalf of The County.

II.

No Waiver of Sovereign Immunity or Powers: Nothing in this agreement will be deemed to constitute a waiver of sovereign immunity or powers of The County, the Williamson County Commissioners Court, or the Williamson County Judge.

III.

No Assignment: DALF may not assign this contract.

IV.

Compliance with All Laws: DALF agrees and will comply with any and all local, state or federal requirements with respect to the services rendered.

V.

Consideration and Compensation: DALF will be compensated based on a cost schedule set forth in DALF's Response to RFP #1771-204. The amount of compensation paid to DALF shall be capped and not-to-exceed **\$80,000.00** for the specific project. **Any vendor reimbursements must comply with the Williamson County Vendor Reimbursement Policy, which is incorporated herein as if copied in full.**

Payment for goods and services shall be governed by Chapter 2251 of the Texas Government Code. An invoice shall be deemed overdue the 31st day after the later of (1) the date The County receives the goods under the contract; (2) the date the performance of the service under the contract is completed; or (3) the date the Williamson County Auditor receives an invoice for the goods or services. Interest charges for any overdue payments shall be paid by The County in accordance with Texas Government Code Section 2251.025. More specifically, the rate of interest that shall accrue on a late payment is the rate in effect on September 1 of The County's fiscal year in which the payment becomes due. The said rate in effect on September 1 shall be equal to the sum of one percent (1%); and (2) the prime rate published in the Wall Street Journal on the first day of July of the preceding fiscal year that does not fall on a Saturday or Sunday.

VI.

Services: DALF shall provide services *as an independent contractor* pursuant to terms and policies of the Williamson County Commissioners Court. DALF expressly acknowledges that it is not an employee of The County. The services include, but are not limited to the following items in order to complete the project:

As described in the attached Proposal/Statement of Work, dated December 27, 2017, which is marked Exhibit "A" and incorporated herein as if copied in full.

VII.

Entire Contract & Incorporated Documents: This Contract constitutes the entire Contract between the parties and may not be modified or amended other than by a written instrument executed by both parties. Documents expressly incorporated (as if

copied in full) into this Contract include the following:

- 1) RFP #1771-204 (Quality Assurance Evaluation for Emergency Communications Radio Traffic);
- 2) DALF's Proposal/Statement of Work, dated December 27, 2017, which is marked Exhibit "A"; and
- 3) Williamson County Vendor Reimbursement Policy.

The County reserves the right and discretion (pursuant to public policy and Texas Constitutional principles) to determine applicable provisions where there is any conflict between this contract and any of the above-referenced contract documents/exhibits or incorporated documents.

VIII.

Good Faith: DALF agrees to act in good faith in the performance of this agreement.

IX.

Ownership and License: DALF retains all ownership and intellectual property rights in techniques, methodology, engineering designs, technology solutions, migration schedules, operational floor layouts, and products (collectively "IP") provided or used by DALF in the performance of services, and any extensions to DALF IP developed in conjunction with the SOW, including but not limited to operating instructions, unique design concepts, development tools, and training materials. DALF grants to County, a perpetual, nonexclusive, nontransferable, worldwide, fully paid up license to use, solely for its own internal business purposes, elements of the Deliverables, which contain DALF IP.

X.

Confidentiality: DALF expressly agrees that it will not use any incidental confidential information that may be obtained while working in a governmental setting for its own benefit, and agrees that it will not enter any unauthorized areas or access confidential information and will not disclose any information to unauthorized third parties, and will take care to guard the security of the information at all times.

XI.

Texas Public Information Act: To the extent, if any, that any provision in this Contract is in conflict with Tex. Gov't Code 552.001 et seq., as amended (the "Public Information Act"), the same shall be of no force or effect. Furthermore, it is expressly

understood and agreed that County, its officers and employees may request advice, decisions and opinions of the Attorney General of the State of Texas in regard to the application of the Public Information Act to any items or information furnished to County as to whether or not the same must be made available to the public. It is further understood that County, its officers and employees shall have the right to rely on the advice, decisions and opinions of the Attorney General, and that County, its officers and employees shall have no liability or obligation to DALF for the disclosure to the public, or to any person or persons, of any items or information furnished to County by DALF in reliance of any advice, decision or opinion of the Attorney General of the State of Texas.

XII.

Termination: This agreement may be terminated at any time at the option of either party, without future or prospective liability for performance upon giving thirty (30) days written notice thereof. In the event of termination, The County will only be liable for its pro rata share of services rendered and goods actually received.

XIII.

Mediation: The parties agree to use mediation for dispute resolution prior to and formal legal action being taken on this Contract.

XIV.

Venue and Applicable Law: Venue of this contract shall be Williamson County, Texas, and the laws of the State of Texas shall govern all terms and conditions.

XV.

Effective Date and Term: This contract shall be in full force and effect when signed by all parties and shall continue for a reasonable time period for the specific project and shall terminate upon project completion or when terminated pursuant to paragraph XII above.

XVI.

Severability: In case any one or more of the provisions contained in this agreement shall for any reason be held to be invalid, illegal, or unenforceable in any respect, such invalidity, illegality, or unenforceability shall not affect any other provision in this agreement and this agreement shall be construed as if such invalid, illegal, or unenforceable provision had never been contained in it.

XVII.

Right to Audit: DALF agrees that The County or its duly authorized representatives shall, until the expiration of three (3) years after final payment under this Contract, have access to and the right to examine and photocopy any and all books, documents, papers and records of DALF which are directly pertinent to the services to be performed under this Contract for the purposes of making audits, examinations, excerpts, and transcriptions. DALF agrees that The County shall have access during normal working hours to all necessary DALF facilities and shall be provided adequate and appropriate work space in order to conduct audits in compliance with the provisions of this section. The County shall give DALF thirty (30) days advance written notice of intended audits and such audits shall be limited to once annually.

XVIII.

County Judge or Presiding Officer Authorized to Sign Contract: The presiding officer of The County's governing body who is authorized to execute this instrument by order duly recorded may execute this contract on behalf of The County.

WITNESS the signatures of all parties in duplicate originals this the _____ day of _____, 2018.

WILLIAMSON COUNTY:

DENISE AMBER LEE FOUNDATION:

Authorized Signature



Authorized Signature
MARK LEE

Exhibit "A"

**RFP 1771-204 Quality Assurance Evaluations for Emergency Communications Radio Traffic
22-Feb-18**

Vendor: The Denise Amber Lee Foundation	
Evaluation Criteria	Evaluator Averages
Technology Requirements (0-25 points)	20.4
Feedback Tool and Evaluation Guidelines (0-10 points)	8.6
Quality Assurance Evaluators Qualifications (0-15 points)	13.4
Ability to meet training/ CE requirements (0-15 Points)	10
Ability to meet all other requirements (0-5 points)	4.8
Price (0-35 points)	24.6
Total	81.8

Evaluator Signatures



Non-voting



Commissioners Court - Regular Session

47.

Meeting Date: 02/27/2018

Economic Development

Submitted For: Charlie Crossfield

Submitted By: Charlie Crossfield, Road Bond

Department: Road Bond

Agenda Category: Executive Session

Information

Agenda Item

Discussion regarding economic development negotiations pursuant to Texas Government Code, Section 551.087:

- a) Business prospect(s) that may locate or expand within Williamson County.
- b) Discuss North Woods Road District.
- c) Project Amazon
- d) Wolf Lakes

Background

Fiscal Impact

From/To	Acct No.	Description	Amount
---------	----------	-------------	--------

Attachments

No file(s) attached.

Form Review

Inbox

County Judge Exec Asst.

Form Started By: Charlie Crossfield

Final Approval Date: 02/22/2018

Reviewed By

Wendy Coco

Date

02/22/2018 09:58 AM

Started On: 02/22/2018 09:56 AM

Commissioners Court - Regular Session

48.

Meeting Date: 02/27/2018

Executive Session

Submitted For: Charlie Crossfield

Submitted By: Charlie Crossfield, Road Bond

Department: Road Bond

Agenda Category: Executive Session

Information

Agenda Item

Discuss real estate matters (EXECUTIVE SESSION as per VTCA Govt. Code sec. 551.072 Deliberation Regarding Real Estate Property if deliberation in an open meeting would have a detrimental effect on the position of the governmental body in negotiations with third person.)

A. Real Estate Owned by Third Parties

1. Preliminary discussions relating to proposed or potential purchase or lease of property owned by third parties

- a) Discuss the acquisition of real property for right-of-way for N. Mays St. Extension
- b) Discuss the acquisition of real property for SW 183 and SH 29 Loop.
- c) Discuss the acquisition of real property for CR 176 at RM 2243
- d) Discuss the acquisition of real property: CR 101
- e) Discuss the acquisition of real property: CR 200
- f) Discuss the acquisition of real property for CR 278 at Bagdad Rd.
- g) Discuss the acquisition of real property for proposed CR 110 project. (All sections)
- h) Discuss the acquisition of real property for County Facilities.
- i) Discuss the acquisition of Easement interests for the Brushy Creek Trail Project.
- j) Discuss the acquisition of real property and easements from San Gabriel River Ranch Subdivision.
- k) Discuss the acquisition of real property for CR 278 @ Bagdad Rd.
- l) Discuss the acquisition of real property for Seward Junction SE Loop.
- m) Discuss the acquisition of real property for SH 29 @ DB Wood.
- n) Discuss the acquisition of real property for Hairy Man Rd.
- o) Discuss the acquisition of real property for SW Bypass.
- p) Discuss Somerset Road Districts No. 3 & 4 reimbursements for acquisition & construction of Reagan Blvd.
- q) Discuss Cedar Hollow low water crossings and Lost River.

B. Property or Real Estate owned by Williamson County

- 1). Preliminary discussions relating to proposed or potential sale or lease of property owned by the County
- a) Discuss County owned real estate containing underground water rights and interests.
- b) Discuss wastewater easements in Berry Springs Park
- c) Discuss sale of County property on Ronald Reagan Blvd.
- d) Discuss possible sale of +/- 10 acres located on Chandler Road near the County Sheriff's Office Training Facility
- e) Potential governmental uses for 8th Street downtown parking lot

C. Consider intervention in lawsuit regarding de-listing of Bone Cave harvestman.

D. Discuss the possible placement of agricultural-related monuments at the Williamson County Exposition Center with the participation of third parties.

E. Discuss the San Gabriel River trail easements.

Background

Fiscal Impact

From/To	Acct No.	Description	Amount
---------	----------	-------------	--------

Attachments

No file(s) attached.

Form Review

Inbox

County Judge Exec Asst.
Form Started By: Charlie Crossfield
Final Approval Date: 02/22/2018

Reviewed By

Wendy Coco

Date

02/22/2018 09:58 AM
Started On: 02/22/2018 09:55 AM

Commissioners Court - Regular Session

57.

Meeting Date: 02/27/2018

FY 19 Budget Workshop

Submitted By: Ashlie Koenig, Budget Office

Department: Budget Office

Agenda Category: Regular Agenda Items

Information

Agenda Item

Recess until 1:30 PM

Budget Kickoff Workshop with Commissioners Court, Human Resources and Auditor's Office to set goals, priorities and objectives for the 2018-2019 budget.

Background

Fiscal Impact

From/To	Acct No.	Description	Amount
---------	----------	-------------	--------

Attachments

No file(s) attached.

Form Review

Inbox

County Judge Exec Asst.

Form Started By: Ashlie Koenig

Final Approval Date: 02/14/2018

Reviewed By

Wendy Coco

Date

02/14/2018 09:08 AM

Started On: 02/13/2018 03:28 PM