



AIA® Document G701™ – 2017

Change Order

PROJECT: *(Name and address)*
 Williamson County
 Animal Shelter Expansion
 1855 SE Inner Loop
 Georgetown, TX 78626

CONTRACT INFORMATION:
 Contract For: General Construction

CHANGE ORDER INFORMATION:
 Change Order Number: 002

Date: 1/8/18

Date: 4/20/18

OWNER: *(Name and address)*
 Williamson County, Texas
 710 Main Street, Suite 101
 Georgetown, TX 78626

ARCHITECT: *(Name and address)*
 Jackson & Ryan Architects
 2370 Rice Boulevard, Suite 210
 Houston, TX 77005

CONTRACTOR: *(Name and address)*
 J.T. Vaughn Construction, LLC
 10355 Westpark Drive
 Houston, TX 77042

THE CONTRACT IS CHANGED AS FOLLOWS:

(Insert a detailed description of the change and, if applicable, attach or reference specific exhibits. Also include agreed upon adjustments attributable to executed Construction Change Directives.)

Change Order No. 2 includes the below listed Vaughn Change Proposals # 6-#10. For Vaughn Project No. 2491-01.

- CP No. 6 - Provide glazed tile to fire room walls per submittal review form Jackson & Ryan
- CP No. 7 - Provide the raising the top of wall elevation at the New Adoptions Building Breezeway 4" per RFI 11
- CP No. 8 - Provide the lowering the Fire Line to avoid conflict with the Sanitary Sewer Line
- CP No. 9 - Provide the rerouting of Wastewater Line and relocating a Fire Hydrant to avoid conflict with the Storm Sewer Line
- CP No. 10 - Provide the removal of the Green Screen Columns from Metalink's Scope Jackson & Ryan Architects

| | |
|--|-----------------|
| The original Contract Sum was | \$ 9,499,295.00 |
| The net change by previously authorized Change Orders | \$ 0.00 |
| The Contract Sum prior to this Change Order was | \$ 9,499,295.00 |
| The Contract Sum will be unchanged by this Change Order in the amount of | \$ 0.00 |
| The new Contract Sum including this Change Order will be | \$ 9,499,295.00 |

The Contract Time will be unchanged by Zero (0) days.
 The new date of Substantial Completion will be 3/6/19

NOTE: This Change Order does not include adjustments to the Contract Sum or Guaranteed Maximum Price, or the Contract Time, that have been authorized by Construction Change Directive until the cost and time have been agreed upon by both the Owner and Contractor, in which case a Change Order is executed to supersede the Construction Change Directive.

NOT VALID UNTIL SIGNED BY THE ARCHITECT, CONTRACTOR AND OWNER.

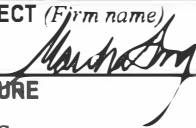
Jackson & Ryan Architects
ARCHITECT *(Firm name)*

 SIGNATURE
 Martha Seng
 PRINTED NAME AND TITLE
 04/25/18
 DATE

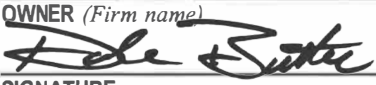
J.T. Vaughn Construction, LLC
CONTRACTOR *(Firm name)*

 SIGNATURE
 Mike Simpson
 PRINTED NAME AND TITLE
 04/23/2018
 DATE

Williamson County, Texas
OWNER *(Firm name)*

 SIGNATURE
 Dale Butler
 PRINTED NAME AND TITLE
 4-26-18
 DATE



Funds Tracking Log

| Change Proposal No. | Change Type & No. | Time Extension (Days) | | GMP Breakdown | | | | | GMP #2491.01 | Total Updated Contract Amount |
|------------------------|-------------------|-----------------------|----------|--------------------|-------------------|-------------------|--------------------|------------------------|--------------------|-------------------------------|
| | | Pending | Approved | Cost of Work | CM Contingency | Owner Contingency | General Conditions | Construction Phase Fee | | |
| N/A | GMP | - | - | \$7,666,840 | \$228,082 | \$300,000 | \$1,034,210 | \$270,163 | \$9,499,295 | \$9,499,295 |
| 1 | OCO 1 | 0 | 0 | \$10,878 | (\$10,964) | \$0 | \$86 | \$0 | \$0 | \$9,499,295 |
| 2 | OCO 1 | 0 | 0 | (\$8,139) | \$8,139 | \$0 | \$0 | \$0 | \$0 | \$9,499,295 |
| 3 | OCO 1 | 0 | 0 | (\$3,945) | \$3,924 | \$0 | \$21 | \$0 | \$0 | \$9,499,295 |
| 4 | OCO 1 | 0 | 0 | \$412 | (\$412) | \$0 | \$0 | \$0 | \$0 | \$9,499,295 |
| 5 | OCO 1 | 0 | 0 | \$11,089 | \$0 | (\$11,615) | \$143 | \$383 | \$0 | \$9,499,295 |
| OCO 1 Totals | | 0 | 0 | \$10,295 | \$687 | (\$11,615) | \$250 | \$383 | \$0 | \$9,499,295 |
| 6 | OCO 2 | 0 | 0 | \$1,423 | \$0 | (\$1,491) | \$18 | \$50 | \$0 | \$9,499,295 |
| 7 | OCO 2 | 0 | 0 | \$769 | \$0 | (\$806) | \$10 | \$27 | \$0 | \$9,499,295 |
| 8 | OCO 2 | 0 | 0 | \$3,595 | (\$3,640) | \$0 | \$45 | \$0 | \$0 | \$9,499,295 |
| 9 | OCO 2 | 0 | 0 | \$16,917 | (\$17,128) | \$0 | \$211 | \$0 | \$0 | \$9,499,295 |
| 10 | OCO 2 | 0 | 0 | (\$9,016) | \$9,016 | \$0 | \$0 | \$0 | \$0 | \$9,499,295 |
| OCO 2 Totals | | 0 | 0 | \$13,688 | (\$11,752) | (\$2,297) | \$284 | \$77 | \$0 | \$9,499,295 |
| 11 | | | | | | | | \$0 | \$0 | \$9,499,295 |
| 12 | | | | | | | | \$0 | \$0 | \$9,499,295 |
| 13 | | | | | | | | \$0 | \$0 | \$9,499,295 |
| 14 | | | | | | | | \$0 | \$0 | \$9,499,295 |
| 15 | | | | | | | | \$0 | \$0 | \$9,499,295 |
| 16 | | | | | | | | \$0 | \$0 | \$9,499,295 |
| 17 | | | | | | | | \$0 | \$0 | \$9,499,295 |
| 18 | | | | | | | | \$0 | \$0 | \$9,499,295 |
| 19 | | | | | | | | \$0 | \$0 | \$9,499,295 |
| 20 | | | | | | | | \$0 | \$0 | \$9,499,295 |
| 21 | | | | | | | | \$0 | \$0 | \$9,499,295 |
| 22 | | | | | | | | \$0 | \$0 | \$9,499,295 |
| 23 | | | | | | | | \$0 | \$0 | \$9,499,295 |
| 24 | | | | | | | | \$0 | \$0 | \$9,499,295 |
| 25 | | | | | | | | \$0 | \$0 | \$9,499,295 |
| 26 | | | | | | | | \$0 | \$0 | \$9,499,295 |
| 27 | | | | | | | | \$0 | \$0 | \$9,499,295 |
| 28 | | | | | | | | \$0 | \$0 | \$9,499,295 |
| 29 | | | | | | | | \$0 | \$0 | \$9,499,295 |
| 30 | | | | | | | | \$0 | \$0 | \$9,499,295 |
| 31 | | | | | | | | \$0 | \$0 | \$9,499,295 |
| 32 | | | | | | | | \$0 | \$0 | \$9,499,295 |
| 33 | | | | | | | | \$0 | \$0 | \$21,530,927 |
| 34 | | | | | | | | \$0 | \$0 | \$9,499,295 |
| 35 | | | | | | | | \$0 | \$0 | \$9,499,295 |
| 36 | | | | | | | | \$0 | \$0 | \$9,499,295 |
| 37 | | | | | | | | \$0 | \$0 | \$9,499,295 |
| 38 | | | | | | | | \$0 | \$0 | \$9,499,295 |
| 39 | | | | | | | | \$0 | \$0 | \$9,499,295 |
| 40 | | | | | | | | \$0 | \$0 | \$9,499,295 |
| Current Amounts | | 0 | 0 | \$7,690,823 | \$217,017 | \$286,088 | \$1,034,744 | \$270,623 | \$9,499,295 | \$9,499,295 |



18551 SE Inner Loop
Georgetown, TX
78626

T: (210) 328-0193

March 30, 2018

Dale Butler
Williamson County
710 Main Street
Georgetown, TX 78626

Re: Animal Shelter Expansion

Job No: 249101

Subj: Change Proposal No. 249101-0006

Dear Sir or Madam:

We respectfully submit our proposal for an increase to our contract in the amount of \$0 (zero) dollars to provide Add Glazed Tile to Fire Room Walls per Submittal Review form Jackson & Ryan for the above referenced project.

Our price is valid for Ten (10) days

Please indicate your acceptance of this change proposal by signing and returning one copy of the attached Form B breakdown of our cost.

Very truly yours,
VAUGHN CONSTRUCTION

A handwritten signature in blue ink, appearing to read "Tom Morrill", written in a cursive style.

Thomas Morrill

Attachments:

CC:

FORM B

PROJECT: Animal Shelter Expansion

CHANGE PROPOSAL NO: 249101-0006

QUOTATION :

| Item | Labor | Materials | Subs | Total |
|---|--------|--------------|------------|--------------|
| Add Glazed Tile to Fire Room Walls per Submittal Review | \$0.00 | \$0.00 | \$1,423.00 | \$1,423.00 |
| Subcontractor Default Insurance | \$0.00 | \$18.00 | \$0.00 | \$18.00 |
| CM Fee | \$0.00 | \$50.00 | \$0.00 | \$50.00 |
| To Be Funded by Owners Contingency | \$0.00 | \$(1,491.00) | \$0.00 | \$(1,491.00) |

| | | | | |
|---------------|--|--------------|------------|---------------|
| Totals | \$0.00 | \$(1,423.00) | \$1,423.00 | \$0.00 |
| | Insurance, Tax, Benefits on Labor | | | \$0.00 |
| | Overhead | | | \$0.00 |
| | Fee on Subs | | | \$0.00 |
| | Fee on JTV | | | \$0.00 |
| | Bond | | | \$0.00 |
| | Remodel Tax | | | \$0.00 |
| | TOTAL | | | \$0.00 |

TIME EXTENSION TO CONTRACT: 0 Days

Submitted Date: 3/30/2018

Accepted

VAUGHN CONSTRUCTION

By: _____

By: 
Thomas Morrill

Date _____

Proposal Valid for 10 Days



Funds Tracking Log

| Change Proposal No. | Change Type & No. | Time Extension (Days) | | GMP Breakdown | | | | | GMP #2491.01 | Total Updated Contract Amount |
|------------------------|-------------------|-----------------------|----------|--------------------|------------------|-------------------|--------------------|------------------------|--------------------|-------------------------------|
| | | Pending | Approved | Cost of Work | CM Contingency | Owner Contingency | General Conditions | Construction Phase Fee | | |
| N/A | GMP | - | - | \$7,666,840 | \$228,082 | \$300,000 | \$1,034,210 | \$270,163 | \$9,499,295 | \$9,499,295 |
| 1 | OCO | 0 | 0 | \$10,878 | (\$10,964) | \$0 | \$86 | \$0 | \$0 | \$9,499,295 |
| 2 | OCO | 0 | 0 | (\$8,139) | \$8,139 | \$0 | \$0 | \$0 | \$0 | \$9,499,295 |
| 3 | OCO | 0 | 0 | (\$3,945) | \$3,924 | \$0 | \$21 | \$0 | \$0 | \$9,499,295 |
| 4 | OCO | 0 | 0 | \$412 | (\$412) | \$0 | \$0 | \$0 | \$0 | \$9,499,295 |
| 5 | OCO | 0 | 0 | \$11,089 | \$0 | (\$11,615) | \$143 | \$383 | \$0 | \$9,499,295 |
| 6 | OCO | 0 | 0 | \$1,423 | \$0 | (\$1,491) | \$18 | \$50 | \$0 | \$9,499,295 |
| 7 | | | | | | | | \$0 | \$0 | \$9,499,295 |
| 8 | | | | | | | | \$0 | \$0 | \$9,499,295 |
| 9 | | | | | | | | \$0 | \$0 | \$9,499,295 |
| 10 | | | | | | | | \$0 | \$0 | \$9,499,295 |
| 11 | | | | | | | | \$0 | \$0 | \$9,499,295 |
| 12 | | | | | | | | \$0 | \$0 | \$9,499,295 |
| 13 | | | | | | | | \$0 | \$0 | \$9,499,295 |
| 14 | | | | | | | | \$0 | \$0 | \$9,499,295 |
| 15 | | | | | | | | \$0 | \$0 | \$9,499,295 |
| 16 | | | | | | | | \$0 | \$0 | \$9,499,295 |
| 17 | | | | | | | | \$0 | \$0 | \$9,499,295 |
| 18 | | | | | | | | \$0 | \$0 | \$9,499,295 |
| 19 | | | | | | | | \$0 | \$0 | \$9,499,295 |
| 20 | | | | | | | | \$0 | \$0 | \$9,499,295 |
| 21 | | | | | | | | \$0 | \$0 | \$9,499,295 |
| 22 | | | | | | | | \$0 | \$0 | \$9,499,295 |
| 23 | | | | | | | | \$0 | \$0 | \$9,499,295 |
| 24 | | | | | | | | \$0 | \$0 | \$9,499,295 |
| 25 | | | | | | | | \$0 | \$0 | \$9,499,295 |
| 26 | | | | | | | | \$0 | \$0 | \$9,499,295 |
| 27 | | | | | | | | \$0 | \$0 | \$9,499,295 |
| 28 | | | | | | | | \$0 | \$0 | \$9,499,295 |
| 29 | | | | | | | | \$0 | \$0 | \$9,499,295 |
| 30 | | | | | | | | \$0 | \$0 | \$9,499,295 |
| 31 | | | | | | | | \$0 | \$0 | \$9,499,295 |
| 32 | | | | | | | | \$0 | \$0 | \$9,499,295 |
| 33 | | | | | | | | \$0 | \$0 | \$21,530,927 |
| 34 | | | | | | | | \$0 | \$0 | \$9,499,295 |
| 35 | | | | | | | | \$0 | \$0 | \$9,499,295 |
| 36 | | | | | | | | \$0 | \$0 | \$9,499,295 |
| 37 | | | | | | | | \$0 | \$0 | \$9,499,295 |
| 38 | | | | | | | | \$0 | \$0 | \$9,499,295 |
| 39 | | | | | | | | \$0 | \$0 | \$9,499,295 |
| 40 | | | | | | | | \$0 | \$0 | \$9,499,295 |
| Current Amounts | | 0 | 0 | \$7,678,558 | \$228,769 | \$286,894 | \$1,034,478 | \$270,596 | \$9,499,295 | \$9,499,295 |



February 8, 2018

ATTN: Brandon Smith
 Vaughn Construction
 6604 N. Lamar
 Austin, Texas 78752

PROJECT: Williamson County Regional Animal Shelter
 LOCATION: Georgetown TX

CHANGE ORDER PROPOSAL

Below you will find pricing to perform additional work on the above referenced project.

DESCRIPTION OF CHANGE:

This price is for changing the fire room from all grey to glazed with grey to 10'8"

Per:

BMI Pricing Request:# 01

| ITEM | QUANTITY | UNIT OF MEASURE | U/P LABOR | TOTAL LABOR | U/P MAT | TOTAL MAT | TOTAL |
|-------------------------------------|----------|-----------------|-----------|-------------|------------|-----------|-------------------|
| 4" Grey block | -60 | ea. | \$ 3.89 | -\$233.40 | \$ 0.92 | -\$55.20 | -\$288.60 |
| 4w4 cobalt | 1 | ea. | \$ 10.46 | \$10.46 | \$ 8.17 | \$8.17 | \$18.63 |
| 4wd cobalt | 11 | ea. | \$ 6.97 | \$76.67 | \$ 7.71 | \$84.81 | \$161.48 |
| 4wd bluebonnet | 1 | ea. | \$ 6.97 | \$6.97 | \$ 7.71 | \$7.71 | \$14.68 |
| 4w4 white | 4 | ea. | \$ 10.46 | \$41.84 | \$ 6.83 | \$27.32 | \$69.16 |
| 4wd white | 42 | ea. | \$ 6.97 | \$292.74 | \$ 6.46 | \$271.32 | \$564.06 |
| 4wd violet shadow | 1 | ea. | \$ 6.97 | \$6.97 | \$ 8.47 | \$8.47 | \$15.44 |
| Pointing Mortar | 161 | L/F | \$ 0.96 | \$154.56 | | \$0.00 | \$154.56 |
| Pointing Mortar | 1.0 | ea. | | | \$ 266.00 | \$266.00 | \$266.00 |
| Wash-down | 27 | sq. ft. | \$ 0.90 | \$24.30 | \$ 0.25 | \$6.75 | \$31.05 |
| Misc. Equipment, materials, access. | 8 | hrs. | | | \$ 20.25 | \$162.00 | \$162.00 |
| SUB TOTAL | | | | \$381.11 | | \$787.35 | \$1,168.46 |
| LABOR BURDEN @ 36.00% | | | | | | | \$137.20 |
| MATERIAL TAX 0.00% | | | | | | | \$0.00 |
| SUB TOTAL | | | | | | | \$1,305.66 |
| OVERHEAD @ 5.00% | | | | | | | \$58.42 |
| PROFIT @ 5.00% | | | | | | | \$58.42 |
| GRAND TOTAL | | | | | Add | | \$1,423.00 |

Duration of Working Days ADDED to Contract Schedule:

Please send a change order as soon as possible if this work is to take place. Work under this proposal will NOT take place unless formal change order is received.

Sincerely,
 Brazos Masonry, Inc.

Jerrad Bohannon

Jerrad Bohannon
 Project Manager



18551 SE Inner Loop
Georgetown, TX
78626

T: (210) 328-0193

March 30, 2018

Dale Butler
Williamson County
710 Main Street
Georgetown, TX 78626

Re: Animal Shelter Expansion

Job No: 249101

Subj: Change Proposal No. 249101-0007

Dear Sir or Madam:

We respectfully submit our proposal for an increase to our contract in the amount of \$0 (zero) dollars to provide raising the top of wall elevation at the New Adoptions Building Breezeway 4" per RFI 11 for the above referenced project.

Our price is valid for Ten (10) days

Please indicate your acceptance of this change proposal by signing and returning one copy of the attached Form B breakdown of our cost.

Very truly yours,
VAUGHN CONSTRUCTION

A handwritten signature in blue ink, appearing to read "Tom Morrill", written over a light blue horizontal line.

Thomas Morrill

Attachments:

CC:

FORM B

PROJECT: Animal Shelter Expansion

CHANGE PROPOSAL NO: 249101-0007

QUOTATION :

| Item | Labor | Materials | Subs | Total |
|--|--------|------------|----------|------------|
| raising the top of wall elevation at the New Adoptions Building Breezeway 4" per RFI 1 | \$0.00 | \$0.00 | \$769.00 | \$769.00 |
| Subcontractor Default Insurance | \$0.00 | \$10.00 | \$0.00 | \$10.00 |
| CM Fee | \$0.00 | \$27.00 | \$0.00 | \$27.00 |
| To Be Funded By Owners Contingency | \$0.00 | \$(806.00) | \$0.00 | \$(806.00) |

| | | | | |
|---------------|--|------------|----------|---------------|
| Totals | \$0.00 | \$(769.00) | \$769.00 | \$0.00 |
| | Insurance, Tax, Benefits on Labor | | | \$0.00 |
| | Overhead | | | \$0.00 |
| | Fee on Subs | | | \$0.00 |
| | Fee on JTV | | | \$0.00 |
| | Bond | | | \$0.00 |
| | Remodel Tax | | | \$0.00 |
| | TOTAL | | | \$0.00 |

TIME EXTENSION TO CONTRACT: 0 Days

Submitted Date: 3/30/2018

Accepted

VAUGHN CONSTRUCTION

By: _____

By: 
Thomas Morrill

Date _____

Proposal Valid for 10 Days



Funds Tracking Log

| Change Proposal No. | Change Type & No. | Time Extension (Days) | | GMP Breakdown | | | | | GMP #2491.01 | Total Updated Contract Amount |
|------------------------|-------------------|-----------------------|----------|--------------------|------------------|-------------------|--------------------|------------------------|--------------------|-------------------------------|
| | | Pending | Approved | Cost of Work | CM Contingency | Owner Contingency | General Conditions | Construction Phase Fee | | |
| N/A | GMP | - | - | \$7,666,840 | \$228,082 | \$300,000 | \$1,034,210 | \$270,163 | \$9,499,295 | \$9,499,295 |
| 1 | OCO | 0 | 0 | \$10,878 | (\$10,964) | \$0 | \$86 | \$0 | \$0 | \$9,499,295 |
| 2 | OCO | 0 | 0 | (\$8,139) | \$8,139 | \$0 | \$0 | \$0 | \$0 | \$9,499,295 |
| 3 | OCO | 0 | 0 | (\$3,945) | \$3,924 | \$0 | \$21 | \$0 | \$0 | \$9,499,295 |
| 4 | OCO | 0 | 0 | \$412 | (\$412) | \$0 | \$0 | \$0 | \$0 | \$9,499,295 |
| 5 | OCO | 0 | 0 | \$11,089 | \$0 | (\$11,615) | \$143 | \$383 | \$0 | \$9,499,295 |
| 6 | OCO | 0 | 0 | \$1,423 | \$0 | (\$1,491) | \$18 | \$50 | \$0 | \$9,499,295 |
| 7 | OCO | 0 | 0 | \$769 | \$0 | (\$806) | \$10 | \$27 | \$0 | \$9,499,295 |
| 8 | | | | | | | | \$0 | \$0 | \$9,499,295 |
| 9 | | | | | | | | \$0 | \$0 | \$9,499,295 |
| 10 | | | | | | | | \$0 | \$0 | \$9,499,295 |
| 11 | | | | | | | | \$0 | \$0 | \$9,499,295 |
| 12 | | | | | | | | \$0 | \$0 | \$9,499,295 |
| 13 | | | | | | | | \$0 | \$0 | \$9,499,295 |
| 14 | | | | | | | | \$0 | \$0 | \$9,499,295 |
| 15 | | | | | | | | \$0 | \$0 | \$9,499,295 |
| 16 | | | | | | | | \$0 | \$0 | \$9,499,295 |
| 17 | | | | | | | | \$0 | \$0 | \$9,499,295 |
| 18 | | | | | | | | \$0 | \$0 | \$9,499,295 |
| 19 | | | | | | | | \$0 | \$0 | \$9,499,295 |
| 20 | | | | | | | | \$0 | \$0 | \$9,499,295 |
| 21 | | | | | | | | \$0 | \$0 | \$9,499,295 |
| 22 | | | | | | | | \$0 | \$0 | \$9,499,295 |
| 23 | | | | | | | | \$0 | \$0 | \$9,499,295 |
| 24 | | | | | | | | \$0 | \$0 | \$9,499,295 |
| 25 | | | | | | | | \$0 | \$0 | \$9,499,295 |
| 26 | | | | | | | | \$0 | \$0 | \$9,499,295 |
| 27 | | | | | | | | \$0 | \$0 | \$9,499,295 |
| 28 | | | | | | | | \$0 | \$0 | \$9,499,295 |
| 29 | | | | | | | | \$0 | \$0 | \$9,499,295 |
| 30 | | | | | | | | \$0 | \$0 | \$9,499,295 |
| 31 | | | | | | | | \$0 | \$0 | \$9,499,295 |
| 32 | | | | | | | | \$0 | \$0 | \$9,499,295 |
| 33 | | | | | | | | \$0 | \$0 | \$21,530,927 |
| 34 | | | | | | | | \$0 | \$0 | \$9,499,295 |
| 35 | | | | | | | | \$0 | \$0 | \$9,499,295 |
| 36 | | | | | | | | \$0 | \$0 | \$9,499,295 |
| 37 | | | | | | | | \$0 | \$0 | \$9,499,295 |
| 38 | | | | | | | | \$0 | \$0 | \$9,499,295 |
| 39 | | | | | | | | \$0 | \$0 | \$9,499,295 |
| 40 | | | | | | | | \$0 | \$0 | \$9,499,295 |
| Current Amounts | | 0 | 0 | \$7,679,327 | \$228,769 | \$286,088 | \$1,034,488 | \$270,623 | \$9,499,295 | \$9,499,295 |

REQUEST FOR INFORMATION



18551 SE Inner Loop
Georgetown, TX
78626

T: (210) 328-0193

RFI NO: 11

To: John Benham
Jackson & Ryan Architects
2370 Rice Boulevard, Suite 210
Houston, TX 77005
Phone: (713) 526-5436
Fax:

Date: 01/31/2018

Required By: 02/07/2018

Owner: Williamson County, Texas

From: Brandon Smith

Job No : 249101

Project: Animal Shelter Expansion
1855 SE Inner Loop
Georgetown, TX 78626

Re: Breezeway CMU Wall Bracing

Spec. Section:

Drawing Number: A.3-6.30, S.3-2.02, & S5.03

Other Reference:

Question:

Detail 7/A.3-6.30 indicates the top of CMU to be 768'-6" at the breezeway wall head. Detail 2/S5.03 indicates a 3"x8" bent plate anchored 4" below the top of CMU and welded to the bottom of the beam. The bottom elevation of the beams running along Gridlines 2 and 3 is roughly 768'-11" resulting in a 5" space between the top of CMU wall and bottom of beam. The spacing between the CMU wall and beam is too large for the bent plate to span and maintain the epoxy bolt anchorage 4" below top of CMU. Please provide a revised detail for the CMU wall bracing at shear walls.

Answer:

Structural detail 2/S5.03 governs. See revised detail 07/A.3-6.30, attached, which coordinates better with 2/S5.03.

John Benham, AIA
Jackson & Ryan Architects

02/02/18

Very truly yours,

VAUGHN CONSTRUCTION

Attachments:

CC:

DATE ISSUED:
 09/27/17
 11/08/17
 11/05/17
 02/02/18

ISSUE FOR PERMIT
 ADDRESS: 1601
 FIRST RE-SUBMITAL - PLAN
 REVISIONS
 R1011

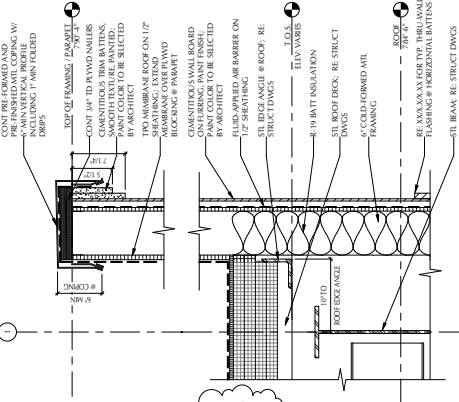

03 SECTION DETAIL @ PARAPET, TYP.
 1 1/2" = 1'-0"

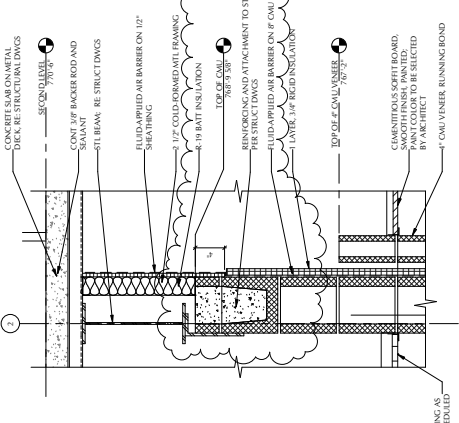

07 SECTION @ BREEZEWAY WALL HEAD
 1 1/2" = 1'-0"

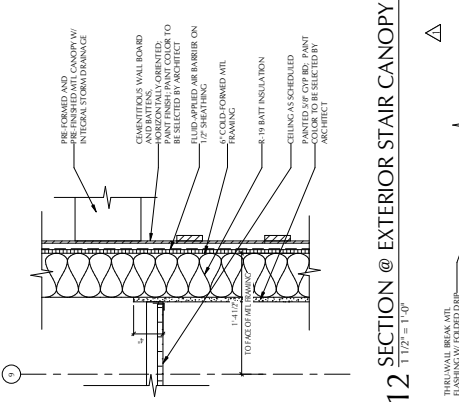

12 SECTION @ EXTERIOR STAIR CANOPY
 1 1/2" = 1'-0"

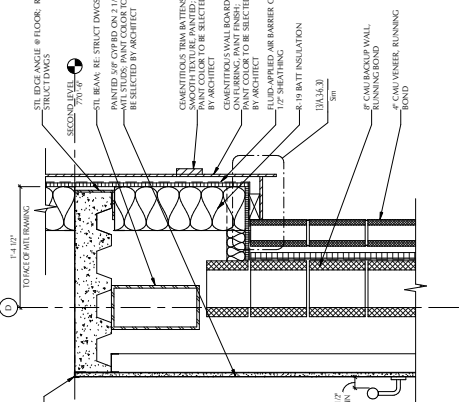

16 SECTION @ INTERIOR STAIRS
 1 1/2" = 1'-0"

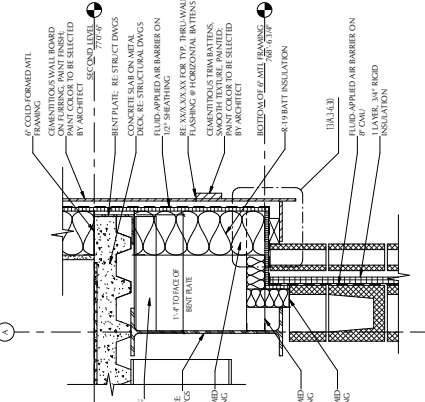

06 SECTION @ SECOND LEVEL EXT. SLAB
 1 1/2" = 1'-0"

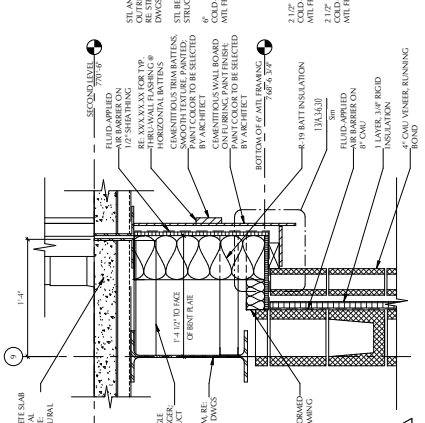

10 SECTION @ CANOPY AND CATIO
 1 1/2" = 1'-0"

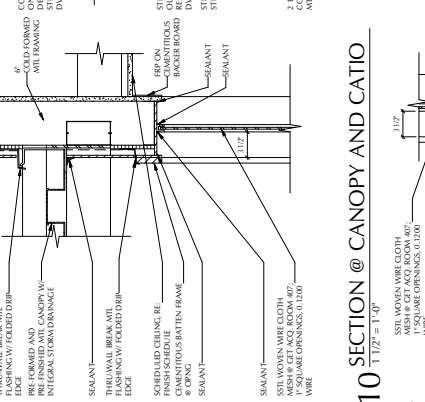

09 SECTION @ CATIO
 1 1/2" = 1'-0"



13 SECTION @ EXT WALL FINISH TRANSITION
 6\"/>

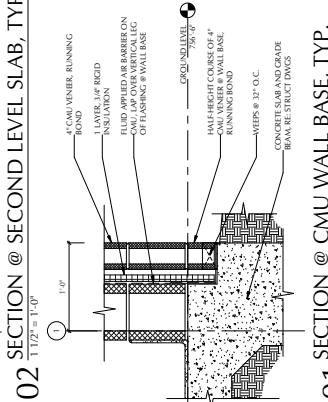

02 SECTION @ SECOND LEVEL SLAB, TYP.
 1 1/2" = 1'-0"

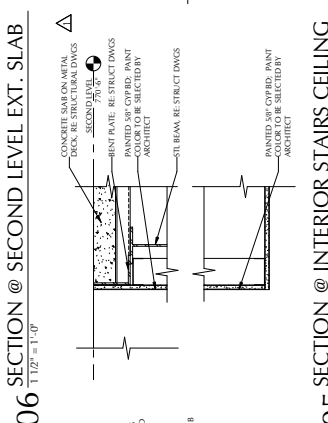

01 SECTION @ CMU WALL BASE, TYP.
 1 1/2" = 1'-0"

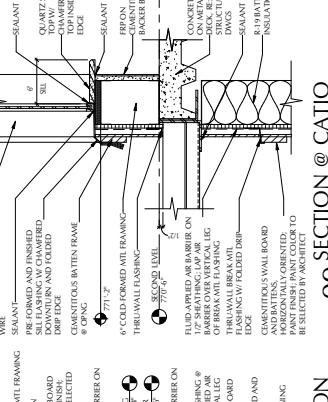

05 SECTION @ INTERIOR STAIRS CEILING
 1 1/2" = 1'-0"

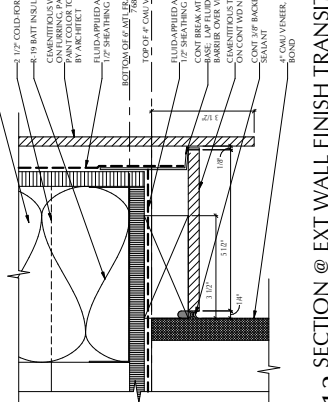

08 SECTION @ INTERIOR STAIRS CEILING
 1 1/2" = 1'-0"

PROJECT NUMBER: 1602
 GEORGETOWN PROJECT NO. 2017-2692

WILLIAMSON COUNTY
 REGIONAL ANIMAL
 SHELTER

1835 SE INNER LOOP
 GEORGETOWN, TX 78626

JACKSON & RYAN ARCHITECTS
 2301 RICE BOULEVARD, HOUSTON, TEXAS 77055

CIVIL ENGINEER
 DANA W. JACKSON
 LICENSED PROFESSIONAL ENGINEER
 512-258-4149
 512-258-4149

STRUCTURAL ENGINEER
 MARYANN RYAN
 LICENSED PROFESSIONAL ENGINEER
 512-862-0333
 713-644-0103

MECHANICAL, ELECTRICAL & PLUMBING ENGINEER
 SHAMUS SMITH
 LICENSED PROFESSIONAL ENGINEER
 512-655-9404

GENERAL CONTRACTOR
 VAUGHN CONSTRUCTION
 512-519-1122

SECTION DETAILS

SCALE: As Indicated

Copyright 2018 by JACKSON & RYAN ARCHITECTS
 All rights reserved. This drawing is the property of JACKSON & RYAN ARCHITECTS. It is to be used only for the project and site specifically identified herein. No part of this drawing may be reproduced, stored in a retrieval system, or transmitted in any form or by any means, electronic, mechanical, photocopying, recording, or by any information storage and retrieval system, without the prior written permission of JACKSON & RYAN ARCHITECTS.

A.3-6-30

Plot Date: 09/27/17



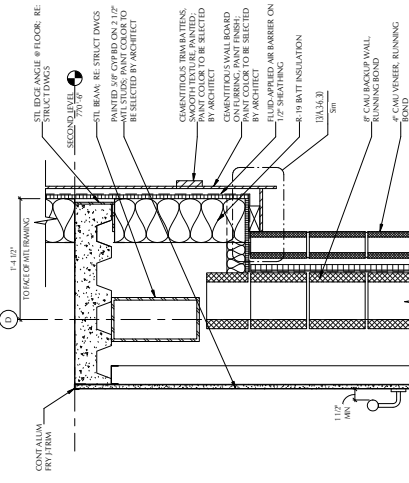

16 SECTION @ INTERIOR STAIRS
1 1/2\"/>

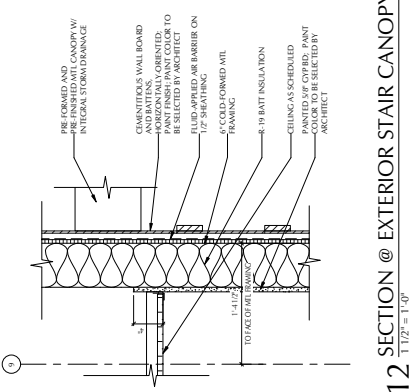

12 SECTION @ EXTERIOR STAIR CANOPY
1 1/2\"/>

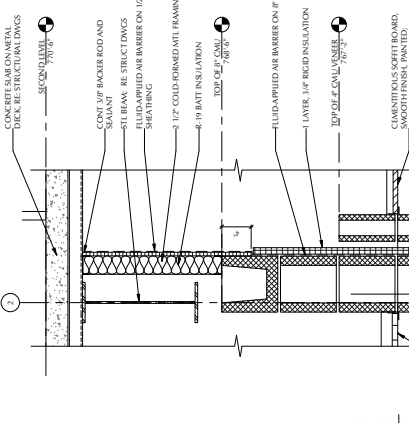

07 SECTION @ BREZEWAY WALL HEAD
1 1/2\"/>

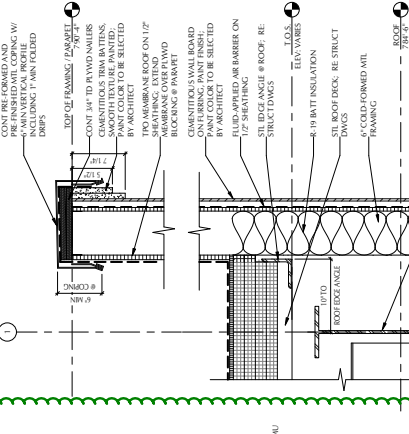

03 SECTION DETAIL @ PARAPET, TYP.
1 1/2\"/>

Date Issued:
09/27/17
10/18/17
11/15/17

ISSUE FOR PERMIT
ADDRESS/NO.01
FIRST RE-SUBMITTAL - PLAN
REVIEW

Project Number:
1602
WILLIAMSON COUNTY
REGIONAL ANIMAL
SHELTER

1855 SE INNER LOOP
GEORGETOWN, TX 78626
JACKSON & RYAN ARCHITECTS
2301 RICE BOULEVARD, HOUSTON, TEXAS 77056

MECHANICAL/ELECTRICAL/PLUMBING ENGINEER
SHAW SMITH ASSOCIATES, INC.
505-954-0404

GENERAL CONTRACTOR
VAUGHN CONSTRUCTION
312-519-1122



Scale: As Indicated
JACKSON & RYAN ARCHITECTS
10000 Katy Freeway, Suite 1000, Houston, TX 77056
Tel: 281.462.1000
www.jrarchitects.com

A.3-6.30
Plot Date: 09/27/17

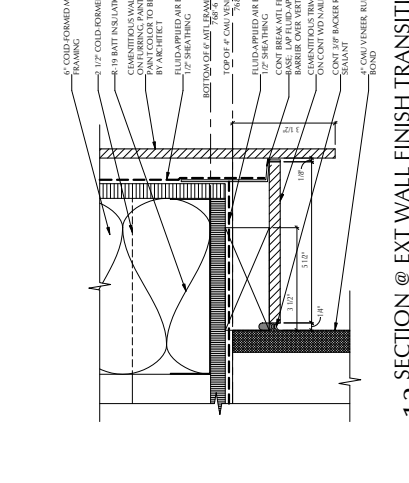

13 SECTION @ EXT WALL FINISH TRANSITION
6\"/>

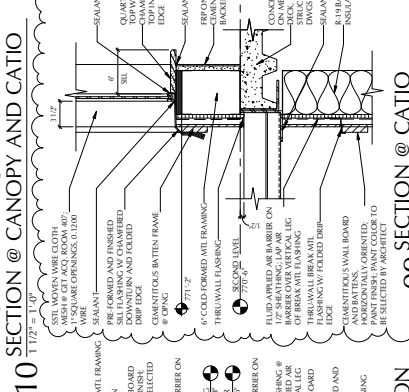

09 SECTION @ CATIO
1 1/2\"/>

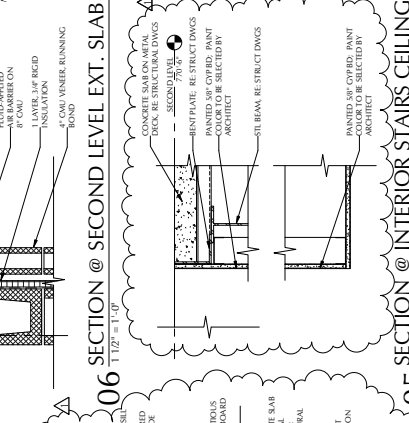

06 SECTION @ SECOND LEVEL EXT. SLAB
1 1/2\"/>

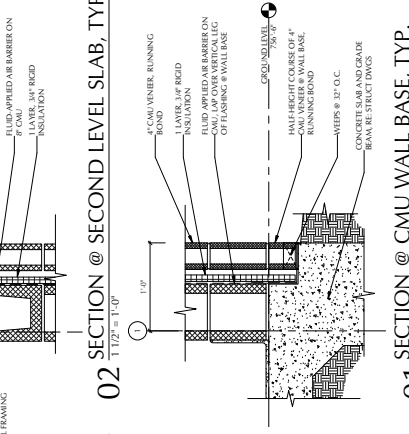

02 SECTION @ SECOND LEVEL SLAB, TYP.
1 1/2\"/>

SECTION DETAILS
Sheet Count: 10/18/17

Inspections must be requested online at www.mygovernmentonline.org



February 8, 2018

ATTN: Brandon Smith
 Vaughn Construction
 6604 N. Lamar
 Austin, Texas 78752

PROJECT: Williamson County Regional Animal Shelter
 LOCATION: Georgetown TX

CHANGE ORDER PROPOSAL

Below you will find pricing to perform additional work on the above referenced project.

DESCRIPTION OF CHANGE:

This price is for raising top of wall at breezeway 4" Per RFI 11

Per:

BMI Pricing Request:# 02

| ITEM | QUANTITY | UNIT OF MEASURE | U/P | TOTAL LABOR | U/P MAT | TOTAL MAT | TOTAL |
|--|----------|-----------------|----------|-------------|------------|-----------|-----------------|
| 8" Grey block | 40 | ea. | \$ 4.02 | \$160.80 | \$ 1.32 | \$52.80 | \$213.60 |
| Grey Mortar | 2 | ea. | \$ - | \$0.00 | \$ 11.65 | \$23.30 | \$23.30 |
| Sand | 0.5 | tons | \$ - | \$0.00 | \$ 32.00 | \$16.00 | \$16.00 |
| Grout (material and labor) | 1 | yds. | \$ 85.00 | \$85.00 | \$ 85.00 | \$85.00 | \$170.00 |
| Joint reinforcement, anchors, access., misc. | 36 | sq. ft. | | | \$ 0.95 | \$34.20 | \$34.20 |
| Misc. Equipment, materials, access. | 8 | hrs. | | | \$ 20.25 | \$162.00 | \$162.00 |
| SUB TOTAL | | | | \$245.80 | | \$373.30 | \$619.10 |
| LABOR BURDEN @ 36.00% | | | | | | | \$88.49 |
| MATERIAL TAX @ 0.00% | | | | | | | \$0.00 |
| SUB TOTAL | | | | | | | \$707.59 |
| OVERHEAD @ 5.00% | | | | | | | \$30.96 |
| PROFIT @ 5.00% | | | | | | | \$30.96 |
| GRAND TOTAL | | | | | Add | | \$769.00 |

Duration of Working Days ADDED to Contract Schedule: 1.00

Please send a change order as soon as possible if this work is to take place. Work under this proposal will NOT take place unless formal change order is received.

Sincerely,
 Brazos Masonry, Inc.

Jerrad Bohannon

 Jerrad Bohannon
 Project Manager



18551 SE Inner Loop
Georgetown, TX
78626

T: (210) 328-0193

March 30, 2018

Dale Butler
Williamson County
710 Main Street
Georgetown, TX 78626

Re: Animal Shelter Expansion

Job No: 249101

Subj: Change Proposal No. 249101-0008

Dear Sir or Madam:

We respectfully submit our proposal for an increase to our contract in the amount of \$0 (zero) dollars to provide Lower the Fire Line to avoid conflict with the Sanitary Sewer Line for the above referenced project.

Our price is valid for Ten (10) days

Please indicate your acceptance of this change proposal by signing and returning one copy of the attached Form B breakdown of our cost.

Very truly yours,
VAUGHN CONSTRUCTION

A handwritten signature in blue ink, appearing to read "Tom Morrill", written over a light blue horizontal line.

Thomas Morrill

Attachments:

CC:

FORM B

PROJECT: Animal Shelter Expansion

CHANGE PROPOSAL NO: 249101-0008

QUOTATION :

| Item | Labor | Materials | Subs | Total |
|--|--------------|------------------|-------------|--------------|
| Lower the Fire Line to avoid conflict with the Sanitary Sewer Line | \$0.00 | \$0.00 | \$3,595.00 | \$3,595.00 |
| Subcontractor Default Insurance | \$0.00 | \$45.00 | \$0.00 | \$45.00 |
| To Be Funded By CM Contingency | \$0.00 | \$(3,640.00) | \$0.00 | \$(3,640.00) |

| | | | | |
|---------------|--|--------------|------------|--------|
| Totals | \$0.00 | \$(3,595.00) | \$3,595.00 | \$0.00 |
| | Insurance, Tax, Benefits on Labor | | | \$0.00 |
| | Overhead | | | \$0.00 |
| | Fee on Subs | | | \$0.00 |
| | Fee on JTV | | | \$0.00 |
| | Bond | | | \$0.00 |
| | Remodel Tax | | | \$0.00 |

| | | | | |
|--|--------------|--|--|---------------|
| | TOTAL | | | \$0.00 |
|--|--------------|--|--|---------------|

TIME EXTENSION TO CONTRACT: 0 Days

Submitted Date: 3/30/2018

Accepted

VAUGHN CONSTRUCTION

By: _____

By: 
Thomas Morrill

Date _____

Proposal Valid for 10 Days



Funds Tracking Log

| Change Proposal No. | Change Type & No. | Time Extension (Days) | | GMP Breakdown | | | | | GMP #2491.01 | Total Updated Contract Amount |
|------------------------|-------------------|-----------------------|----------|--------------------|------------------|-------------------|--------------------|------------------------|--------------------|-------------------------------|
| | | Pending | Approved | Cost of Work | CM Contingency | Owner Contingency | General Conditions | Construction Phase Fee | | |
| N/A | GMP | - | - | \$7,666,840 | \$228,082 | \$300,000 | \$1,034,210 | \$270,163 | \$9,499,295 | \$9,499,295 |
| 1 | OCO | 0 | 0 | \$10,878 | (\$10,964) | \$0 | \$86 | \$0 | \$0 | \$9,499,295 |
| 2 | OCO | 0 | 0 | (\$8,139) | \$8,139 | \$0 | \$0 | \$0 | \$0 | \$9,499,295 |
| 3 | OCO | 0 | 0 | (\$3,945) | \$3,924 | \$0 | \$21 | \$0 | \$0 | \$9,499,295 |
| 4 | OCO | 0 | 0 | \$412 | (\$412) | \$0 | \$0 | \$0 | \$0 | \$9,499,295 |
| 5 | OCO | 0 | 0 | \$11,089 | \$0 | (\$11,615) | \$143 | \$383 | \$0 | \$9,499,295 |
| 6 | OCO | 0 | 0 | \$1,423 | \$0 | (\$1,491) | \$18 | \$50 | \$0 | \$9,499,295 |
| 7 | OCO | 0 | 0 | \$769 | \$0 | (\$806) | \$10 | \$27 | \$0 | \$9,499,295 |
| 8 | OCO | 0 | 0 | \$3,595 | (\$3,640) | \$0 | \$45 | \$0 | \$0 | \$9,499,295 |
| 9 | | | | | | | | \$0 | \$0 | \$9,499,295 |
| 10 | | | | | | | | \$0 | \$0 | \$9,499,295 |
| 11 | | | | | | | | \$0 | \$0 | \$9,499,295 |
| 12 | | | | | | | | \$0 | \$0 | \$9,499,295 |
| 13 | | | | | | | | \$0 | \$0 | \$9,499,295 |
| 14 | | | | | | | | \$0 | \$0 | \$9,499,295 |
| 15 | | | | | | | | \$0 | \$0 | \$9,499,295 |
| 16 | | | | | | | | \$0 | \$0 | \$9,499,295 |
| 17 | | | | | | | | \$0 | \$0 | \$9,499,295 |
| 18 | | | | | | | | \$0 | \$0 | \$9,499,295 |
| 19 | | | | | | | | \$0 | \$0 | \$9,499,295 |
| 20 | | | | | | | | \$0 | \$0 | \$9,499,295 |
| 21 | | | | | | | | \$0 | \$0 | \$9,499,295 |
| 22 | | | | | | | | \$0 | \$0 | \$9,499,295 |
| 23 | | | | | | | | \$0 | \$0 | \$9,499,295 |
| 24 | | | | | | | | \$0 | \$0 | \$9,499,295 |
| 25 | | | | | | | | \$0 | \$0 | \$9,499,295 |
| 26 | | | | | | | | \$0 | \$0 | \$9,499,295 |
| 27 | | | | | | | | \$0 | \$0 | \$9,499,295 |
| 28 | | | | | | | | \$0 | \$0 | \$9,499,295 |
| 29 | | | | | | | | \$0 | \$0 | \$9,499,295 |
| 30 | | | | | | | | \$0 | \$0 | \$9,499,295 |
| 31 | | | | | | | | \$0 | \$0 | \$9,499,295 |
| 32 | | | | | | | | \$0 | \$0 | \$9,499,295 |
| 33 | | | | | | | | \$0 | \$0 | \$21,530,927 |
| 34 | | | | | | | | \$0 | \$0 | \$9,499,295 |
| 35 | | | | | | | | \$0 | \$0 | \$9,499,295 |
| 36 | | | | | | | | \$0 | \$0 | \$9,499,295 |
| 37 | | | | | | | | \$0 | \$0 | \$9,499,295 |
| 38 | | | | | | | | \$0 | \$0 | \$9,499,295 |
| 39 | | | | | | | | \$0 | \$0 | \$9,499,295 |
| 40 | | | | | | | | \$0 | \$0 | \$9,499,295 |
| Current Amounts | | 0 | 0 | \$7,682,922 | \$225,129 | \$286,088 | \$1,034,533 | \$270,623 | \$9,499,295 | \$9,499,295 |



P.O. Box 1057
Round Rock, TX 78680
(512) 244-0600
Fax: (512) 244-0489

17207 - WILCO ANIMAL SHELTER STORM CONFLICT CHANGE PROPOSAL 2

03/22/18

| DESCRIPTION | Q'TY | UNIT | TOTAL BID |
|--------------------------------|------|------|--------------------|
| WATER CONFLICT | | | |
| REALIGN WATER | 1 | LS | |
| SUBTOTAL WATER CONFLICT | | | \$ 3,595.00 |



18551 SE Inner Loop
Georgetown, TX
78626

T: (210) 328-0193

March 30, 2018

Dale Butler
Williamson County
710 Main Street
Georgetown, TX 78626

Re: Animal Shelter Expansion

Job No: 249101

Subj: Change Proposal No. 249101-0009

Dear Sir or Madam:

We respectfully submit our proposal for an increase to our contract in the amount of \$0 (zero) dollars to provide Rerouting Wastewater Line and relocating a Fire Hydrant to avoid conflict with the Storm Sewer Line for the above referenced project.

Our price is valid for Ten (10) days

Please indicate your acceptance of this change proposal by signing and returning one copy of the attached Form B breakdown of our cost.

Very truly yours,
VAUGHN CONSTRUCTION

A handwritten signature in blue ink, appearing to read "Tom Morrill", written in a cursive style.

Thomas Morrill

Attachments:

CC:

FORM B

PROJECT: Animal Shelter Expansion

CHANGE PROPOSAL NO: 249101-0009

QUOTATION :

| Item | Labor | Materials | Subs | Total |
|--|--------------|------------------|-------------|---------------|
| Rerouting Wastewater Line and relocating a Fire Hydrant to avoid conflict the Storm Sewer Line | \$0.00 | \$0.00 | \$16,917.00 | \$16,917.00 |
| Subcontractor Default Insurance | \$0.00 | \$211.00 | \$0.00 | \$211.00 |
| To Be Funded By CM Contingency | \$0.00 | \$(17,128.00) | \$0.00 | \$(17,128.00) |

| | | | | |
|--|--------|---------------|-------------|--------|
| Totals | \$0.00 | \$(16,917.00) | \$16,917.00 | \$0.00 |
| Insurance, Tax, Benefits on Labor | | | | \$0.00 |
| Overhead | | | | \$0.00 |
| Fee on Subs | | | | \$0.00 |
| Fee on JTV | | | | \$0.00 |
| Bond | | | | \$0.00 |
| Remodel Tax | | | | \$0.00 |

| | | | | |
|--------------|--|--|--|---------------|
| TOTAL | | | | \$0.00 |
|--------------|--|--|--|---------------|

TIME EXTENSION TO CONTRACT: 0 Days

Submitted Date: 3/30/2018

Accepted

VAUGHN CONSTRUCTION

By: _____

By: 

Thomas Morrill

Date _____

Proposal Valid for 10 Days



Funds Tracking Log

| Change Proposal No. | Change Type & No. | Time Extension (Days) | | GMP Breakdown | | | | | GMP #2491.01 | Total Updated Contract Amount |
|------------------------|-------------------|-----------------------|----------|--------------------|------------------|-------------------|--------------------|------------------------|--------------------|-------------------------------|
| | | Pending | Approved | Cost of Work | CM Contingency | Owner Contingency | General Conditions | Construction Phase Fee | | |
| N/A | GMP | - | - | \$7,666,840 | \$228,082 | \$300,000 | \$1,034,210 | \$270,163 | \$9,499,295 | \$9,499,295 |
| 1 | OCO | 0 | 0 | \$10,878 | (\$10,964) | \$0 | \$86 | \$0 | \$0 | \$9,499,295 |
| 2 | OCO | 0 | 0 | (\$8,139) | \$8,139 | \$0 | \$0 | \$0 | \$0 | \$9,499,295 |
| 3 | OCO | 0 | 0 | (\$3,945) | \$3,924 | \$0 | \$21 | \$0 | \$0 | \$9,499,295 |
| 4 | OCO | 0 | 0 | \$412 | (\$412) | \$0 | \$0 | \$0 | \$0 | \$9,499,295 |
| 5 | OCO | 0 | 0 | \$11,089 | \$0 | (\$11,615) | \$143 | \$383 | \$0 | \$9,499,295 |
| 6 | OCO | 0 | 0 | \$1,423 | \$0 | (\$1,491) | \$18 | \$50 | \$0 | \$9,499,295 |
| 7 | OCO | 0 | 0 | \$769 | \$0 | (\$806) | \$10 | \$27 | \$0 | \$9,499,295 |
| 8 | OCO | 0 | 0 | \$3,595 | (\$3,640) | \$0 | \$45 | \$0 | \$0 | \$9,499,295 |
| 9 | OCO | 0 | 0 | \$16,917 | (\$17,128) | \$0 | \$211 | \$0 | \$0 | \$9,499,295 |
| 10 | | | | | | | | \$0 | \$0 | \$9,499,295 |
| 11 | | | | | | | | \$0 | \$0 | \$9,499,295 |
| 12 | | | | | | | | \$0 | \$0 | \$9,499,295 |
| 13 | | | | | | | | \$0 | \$0 | \$9,499,295 |
| 14 | | | | | | | | \$0 | \$0 | \$9,499,295 |
| 15 | | | | | | | | \$0 | \$0 | \$9,499,295 |
| 16 | | | | | | | | \$0 | \$0 | \$9,499,295 |
| 17 | | | | | | | | \$0 | \$0 | \$9,499,295 |
| 18 | | | | | | | | \$0 | \$0 | \$9,499,295 |
| 19 | | | | | | | | \$0 | \$0 | \$9,499,295 |
| 20 | | | | | | | | \$0 | \$0 | \$9,499,295 |
| 21 | | | | | | | | \$0 | \$0 | \$9,499,295 |
| 22 | | | | | | | | \$0 | \$0 | \$9,499,295 |
| 23 | | | | | | | | \$0 | \$0 | \$9,499,295 |
| 24 | | | | | | | | \$0 | \$0 | \$9,499,295 |
| 25 | | | | | | | | \$0 | \$0 | \$9,499,295 |
| 26 | | | | | | | | \$0 | \$0 | \$9,499,295 |
| 27 | | | | | | | | \$0 | \$0 | \$9,499,295 |
| 28 | | | | | | | | \$0 | \$0 | \$9,499,295 |
| 29 | | | | | | | | \$0 | \$0 | \$9,499,295 |
| 30 | | | | | | | | \$0 | \$0 | \$9,499,295 |
| 31 | | | | | | | | \$0 | \$0 | \$9,499,295 |
| 32 | | | | | | | | \$0 | \$0 | \$9,499,295 |
| 33 | | | | | | | | \$0 | \$0 | \$21,530,927 |
| 34 | | | | | | | | \$0 | \$0 | \$9,499,295 |
| 35 | | | | | | | | \$0 | \$0 | \$9,499,295 |
| 36 | | | | | | | | \$0 | \$0 | \$9,499,295 |
| 37 | | | | | | | | \$0 | \$0 | \$9,499,295 |
| 38 | | | | | | | | \$0 | \$0 | \$9,499,295 |
| 39 | | | | | | | | \$0 | \$0 | \$9,499,295 |
| 40 | | | | | | | | \$0 | \$0 | \$9,499,295 |
| Current Amounts | | 0 | 0 | \$7,699,839 | \$208,001 | \$286,088 | \$1,034,744 | \$270,623 | \$9,499,295 | \$9,499,295 |



P.O. Box 1057
 Round Rock, TX 78680
 (512) 244-0600
 Fax: (512) 244-0489

17207 - WILCO ANIMAL SHELTER 30" STORM CONFLICT CHANGE PROPOSAL

03/01/18

| DESCRIPTION | Q'TY | UNIT | TOTAL BID |
|---|------|------|--------------------|
| WASTEWATER LATERALS | | | |
| DEMO. & REPLACE CURB | 5 | LF | |
| DEMO. EXISTING LATERAL | 2 | EA | |
| NEW 4" SDR 26 LATERAL | 2 | EA | |
| SUBTOTAL WASTEWATER LATERALS | | | \$ 7,577.00 |
| FIRE HYDRANT RELOCATION | | | |
| FIRE HYDRANT ASSEMBLY | 1 | EA | |
| FIRE HYDRANT LEAD | 36 | LF | |
| DEMO. & CAP EXISTING LEAD | 1 | LS | |
| SUBTOTAL FIRE HYDRANT RELOCATION | | | \$ 9,340.00 |



18551 SE Inner Loop
Georgetown, TX
78626

T: (210) 328-0193

March 30, 2018

Dale Butler
Williamson County
710 Main Street
Georgetown, TX 78626

Re: Animal Shelter Expansion

Job No: 249101

Subj: Change Proposal No. 249101-0010

Dear Sir or Madam:

We respectfully submit our proposal for an increase to our contract in the amount of \$0 (zero) dollars to provide remove Green Screen Columns from Metalink's Scope for the above referenced project.

Our price is valid for Ten (10) days

Please indicate your acceptance of this change proposal by signing and returning one copy of the attached Form B breakdown of our cost.

Very truly yours,
VAUGHN CONSTRUCTION

A handwritten signature in blue ink, appearing to read "Tom Morrill", written over a light blue horizontal line.

Thomas Morrill

Attachments:

CC:

FORM B

PROJECT: Animal Shelter Expansion

CHANGE PROPOSAL NO: 249101-0010

QUOTATION :

| Item | Labor | Materials | Subs | Total |
|---|--------------|------------------|--------------|--------------|
| remove Green Screen Columns from Metalink's Scope | \$0.00 | \$0.00 | \$(9,016.00) | \$(9,016.00) |
| To Be Credited To CM Contingency | \$0.00 | \$9,016.00 | \$0.00 | \$9,016.00 |

Totals \$0.00 \$9,016.00 \$(9,016.00) \$0.00

Insurance, Tax, Benefits on Labor \$0.00

Overhead \$0.00

Fee on Subs \$0.00

Fee on JTV \$0.00

Bond \$0.00

Remodel Tax \$0.00

TOTAL **\$0.00**

TIME EXTENSION TO CONTRACT: 0 Days

Submitted Date: 4/2/2018

Accepted

VAUGHN CONSTRUCTION

By: _____

By: 

Thomas Morrill

Date _____

Proposal Valid for 10 Days



Funds Tracking Log

| Change Proposal No. | Change Type & No. | Time Extension (Days) | | GMP Breakdown | | | | | GMP #2491.01 | Total Updated Contract Amount |
|------------------------|-------------------|-----------------------|----------|--------------------|------------------|-------------------|--------------------|------------------------|--------------------|-------------------------------|
| | | Pending | Approved | Cost of Work | CM Contingency | Owner Contingency | General Conditions | Construction Phase Fee | | |
| N/A | GMP | - | - | \$7,666,840 | \$228,082 | \$300,000 | \$1,034,210 | \$270,163 | \$9,499,295 | \$9,499,295 |
| 1 | OCO | 0 | 0 | \$10,878 | (\$10,964) | \$0 | \$86 | \$0 | \$0 | \$9,499,295 |
| 2 | OCO | 0 | 0 | (\$8,139) | \$8,139 | \$0 | \$0 | \$0 | \$0 | \$9,499,295 |
| 3 | OCO | 0 | 0 | (\$3,945) | \$3,924 | \$0 | \$21 | \$0 | \$0 | \$9,499,295 |
| 4 | OCO | 0 | 0 | \$412 | (\$412) | \$0 | \$0 | \$0 | \$0 | \$9,499,295 |
| 5 | OCO | 0 | 0 | \$11,089 | \$0 | (\$11,615) | \$143 | \$383 | \$0 | \$9,499,295 |
| 6 | OCO | 0 | 0 | \$1,423 | \$0 | (\$1,491) | \$18 | \$50 | \$0 | \$9,499,295 |
| 7 | OCO | 0 | 0 | \$769 | \$0 | (\$806) | \$10 | \$27 | \$0 | \$9,499,295 |
| 8 | OCO | 0 | 0 | \$3,595 | (\$3,640) | \$0 | \$45 | \$0 | \$0 | \$9,499,295 |
| 9 | OCO | 0 | 0 | \$16,917 | (\$17,128) | \$0 | \$211 | \$0 | \$0 | \$9,499,295 |
| 10 | OCO | 0 | 0 | (\$9,016) | \$9,016 | \$0 | \$0 | \$0 | \$0 | \$9,499,295 |
| 11 | | | | | | | | \$0 | \$0 | \$9,499,295 |
| 12 | | | | | | | | \$0 | \$0 | \$9,499,295 |
| 13 | | | | | | | | \$0 | \$0 | \$9,499,295 |
| 14 | | | | | | | | \$0 | \$0 | \$9,499,295 |
| 15 | | | | | | | | \$0 | \$0 | \$9,499,295 |
| 16 | | | | | | | | \$0 | \$0 | \$9,499,295 |
| 17 | | | | | | | | \$0 | \$0 | \$9,499,295 |
| 18 | | | | | | | | \$0 | \$0 | \$9,499,295 |
| 19 | | | | | | | | \$0 | \$0 | \$9,499,295 |
| 20 | | | | | | | | \$0 | \$0 | \$9,499,295 |
| 21 | | | | | | | | \$0 | \$0 | \$9,499,295 |
| 22 | | | | | | | | \$0 | \$0 | \$9,499,295 |
| 23 | | | | | | | | \$0 | \$0 | \$9,499,295 |
| 24 | | | | | | | | \$0 | \$0 | \$9,499,295 |
| 25 | | | | | | | | \$0 | \$0 | \$9,499,295 |
| 26 | | | | | | | | \$0 | \$0 | \$9,499,295 |
| 27 | | | | | | | | \$0 | \$0 | \$9,499,295 |
| 28 | | | | | | | | \$0 | \$0 | \$9,499,295 |
| 29 | | | | | | | | \$0 | \$0 | \$9,499,295 |
| 30 | | | | | | | | \$0 | \$0 | \$9,499,295 |
| 31 | | | | | | | | \$0 | \$0 | \$9,499,295 |
| 32 | | | | | | | | \$0 | \$0 | \$9,499,295 |
| 33 | | | | | | | | \$0 | \$0 | \$21,530,927 |
| 34 | | | | | | | | \$0 | \$0 | \$9,499,295 |
| 35 | | | | | | | | \$0 | \$0 | \$9,499,295 |
| 36 | | | | | | | | \$0 | \$0 | \$9,499,295 |
| 37 | | | | | | | | \$0 | \$0 | \$9,499,295 |
| 38 | | | | | | | | \$0 | \$0 | \$9,499,295 |
| 39 | | | | | | | | \$0 | \$0 | \$9,499,295 |
| 40 | | | | | | | | \$0 | \$0 | \$9,499,295 |
| Current Amounts | | 0 | 0 | \$7,690,823 | \$217,017 | \$286,088 | \$1,034,744 | \$270,623 | \$9,499,295 | \$9,499,295 |



QUOTATION

Quote Number: 8694
 Quote Date: Feb 1, 2018
 Page: 1

9201 HIGHWAY 183 SOUTH
 AUSTIN, TX 78747-2058

Voice: 512-243-2900
 Fax: 512-243-2907

| |
|---|
| Quoted To: |
| VAUGHN CONSTRUCTION 6604 N Lamar Austin, TX 78752 |

| |
|---|
| Ship To: |
| VAUGHN CONSTRUCTION THOMAS MORRILL WILCO REG. ANIMAL SHELTER EXP. GEOREGTOWN, TX |

| Customer ID | Good Thru | Payment Terms | Sales Rep |
|----------------------|-----------|---------------|-----------|
| VAUGHN CONST-UNIVERS | 3/3/18 | Net 30 Days | DEVIN |

| Quantity | Item | Description | Unit Price | Amount |
|----------|------|--|------------|-----------|
| 1.00 | | DELETE FURNISH & INSTALL STRUCTURAL COLUMNS INCLUDING BASE PLATES, ANCHORS, AND BUILDING TIE BACKS FOR THE GREEN SCREEN WALL. CREDIT | 9,016.00 | -9,016.00 |
| 1.00 | | ALL STRUCTURAL STEEL TO BE FURNISH AND INSTALLED BY OTHERS. | | |
| 1.00 | | METALINK TO FURNISH AND INSTALL GREENSCREEN PANELS, ARTISAN PANELS AND ASSOCIATED HARDWARE. | | |

Please note that there is a 25% re-stocking fee on all material orders that are returned or cancelled.

| | |
|--------------|------------------|
| Subtotal | -9,016.00 |
| Sales Tax | |
| TOTAL | -9,016.00 |

Thank You for your business Have a Great Day!