

QUOTE TO: WilCo Facilities
FOR THE PROJECT: WilCo 350 Discovery Blvd.
ATTENTION: Toby Bonnet
EMAIL: tbonnet@wilco.org

DATE: March 12, 2019

WILCO 350 DISCOVERY BLVD – CHILLER REPLACEMENT PROPOSAL
TIPS-180205

We offer the following proposal for your consideration for the chiller replacement scope of work on the above referenced project. Subject to the following scope narrative, exclusions & clarifications.

CHILLER REPLACEMENT PRICE: \$ 119,400.00

INCLUDED IN CHILLER REPLACEMENT PRICE:

1. Disconnect and remove chiller from site
2. Provide and install (1) new Carrier 130-ton chiller
3. Reconnect chiller piping. Modify piping as required
4. Disconnect temporary chiller
5. Provide new insulation for chilled water piping where removed for installation of new piping
6. Remove chiller construction debris from site
7. Start-up of equipment
8. One-year standard warranty
9. Chiller extended warranty. Parts only years 2-5

NOT INCLUDED IN PRICE:

1. Equipment service or maintenance, except for warranty purposes
2. Electrical
3. Controls
4. Consequential damages
5. Liquidated damages
6. Delays beyond Mtech Icon's control
7. Allowances / alternates not specifically noted above
8. Repairs to existing material or equipment not specifically noted above
9. Engineering work of any kind
10. 3rd Party testing of any kind not specifically noted above
11. Remodel taxes

Bart Hoover
Chief Estimator
512-908-1069
bart.hoover@csusa.us



SUBMITTAL

Project

Wilco 350 Discovery Blvd

Date

Tuesday, March 5, 2019

General Contractor

Mechanical Contractor

Mechanical Engineer

Matt Walker

Table Of Contents

Project: Wilco 350 Discovery Blvd
Prepared By: Matt Walker

03/07/2019
03:39PM

Chiller 1 No Bacnet	3
Unit Report.....	4
Certified Drawing.....	5
Field Wiring Diagram.....	6
Guide Specifications.....	10
DEWA Report.....	14
Detailed Performance Report.....	15

Chiller 1 No Bacnet

**Tag Cover Sheet
Unit Report
Certified Drawing
Wiring Diagram
Performance Report
Guide Specification
Dewa Report
Detailed Performance Report
Engineering Report**

Unit Report For Chiller 1 No Bacnet

Project: Wilco 350 Discovery Blvd
 Prepared By: Matt Walker

03/07/2019
 03:39PM

Unit Information

Tag Name:..... **Chiller 1 No Bacnet**
 Model Number:..... **30RB130**
 Condenser Type:..... **Air Cooled**
 Compressor Type:..... **Scroll**
 Nameplate Voltage:..... **460-3-60** V-Ph-Hz
 Quantity:..... **1**
 Manufacturing Source:..... **Charlotte, NC USA**
 Refrigerant:..... **R410A**
 Independent Refrigerant Circuits:..... **2**
 Capacity Control Steps:..... **6**
 Minimum Capacity:..... **15.0** %
 Shipping Weight:..... **7027** lb
 Operating Weight:..... **7402** lb
 Unit Length:..... **189** in
 Unit Width:..... **89** in
 Unit Height:..... **90** in

Accessories and Installed Options

Freeze Protection
 Suction Line Insulation
 Micro Channel
 Low Sound Option
 Single Point
 Coil Trim Panels
 Greenspeed Intelligence: High-Efficiency Variable Condenser Fans

Chiller Warranty Information (Note: for US & Canada only)

First Year - Parts Only (Standard)
 Complete Unit Years 2-5 Parts Only
 Start-up and Complete Unit 1st Year Labor, First Unit

Ordering Information

Part Number	Description	Quantity
30RBX13064-LLG-3	Packaged Chiller	1
	Base Unit	
	Freeze Protection	
	Suction Line Insulation	
	Micro Channel	
	Low Sound Option	
	Single Point	
	Coil Trim Panels	
	Greenspeed Intelligence: High-Efficiency Variable Condenser Fans	

Field Wiring Diagram for Chiller 1 No Bacnet

Project: Wilco 350 Discovery Blvd
Prepared By: Matt Walker

03/07/2019
03:39PM

NOTES:

1. FACTORY WIRING IS IN ACCORDANCE WITH UL 1995 STANDARDS. FIELD MODIFICATIONS OR ADDITIONS MUST BE IN COMPLIANCE WITH ALL APPLICABLE CODES.
2. WIRING FOR MAIN FIELD SUPPLY MUST BE RATED 75C MINIMUM. USE COPPER FOR ALL UNITS.
INCOMING WIRE SIZE RANGE FOR THE TERMINAL BLOCK IS #4 AWG TO 500 KCMIL.
INCOMING WIRE SIZE RANGE OF NON-FUSED DISCONNECT WITH MCA UP TO 599.9 AMPS IS 3/0 TO 500 KCMIL.
INCOMING WIRE SIZE RANGE OF NON-FUSED DISCONNECT WITH MCA FROM 600 TO 799.9 AMPS IS 1/0 TO 500 KCMIL.
INCOMING WIRE SIZE RANGE OF NON-FUSED DISCONNECT WITH MCA FROM 800 TO 1199.9 AMPS IS 250 KCMIL TO 500 KCMIL.
3. TERMINALS 9 AND 10 OF TBS ARE FOR FIELD EXTERNAL CONNECTIONS FOR REMOTE ON-OFF. THE CONTACTS MUST BE RATED FOR DRY CIRCUIT APPLICATION CAPABLE OF HANDLING A 24VAC LOAD UP TO 50 MA.
4. TERMINALS 1 AND 2 OF TBS ARE FOR EXTERNAL CONNECTIONS OF CHILLED WATER PUMP INTERLOCK. THE CONTACTS MUST BE RATED FOR DRY CIRCUIT APPLICATION CAPABLE OF HANDLING A 24VAC LOAD UP TO 50 MA.
5. TERMINALS 11 AND 13 OF TBS ARE FOR CONTROL OF CHILLED WATER PUMP1 (PMP1) STARTER. TERMINALS 13 AND 15 OF TBS ARE FOR CONTROL OF CHILLED WATER PUMP2 (PMP2) STARTER. THE MAXIMUM LOAD ALLOWED FOR THE CHILLED WATER PUMP RELAY IS 5 VA SEALED, 10 VA INRUSH AT 24V. FIELD POWER SUPPLY IS NOT REQUIRED.
6. FOR CONTROL OF CHILLED WATER PUMPS, A SET OF NORMALLY OPEN CONTACTS RATED FOR DRY CIRCUIT APPLICATION MUST BE SUPPLIED FROM FIELD SUPPLIED PUMP STARTER RELAY. CONNECT CONTACTS TO VIOLET AND PINK WIRES IN HARNESS FROM MAIN BASE BOARD CHANNEL 18. WIRES IN HARNESS ARE MARKED PMP1-13 AND PMP1-14.
7. TERMINALS 12 AND 13 OF TBS ARE FOR A ALARM RELAY. THE MAXIMUM LOAD ALLOWED FOR THE ALARM RELAY IS 10 VA SEALED, 25 VA INRUSH AT 24V. FIELD POWER SUPPLY IS NOT REQUIRED.
8. MAKE APPROPRIATE CONNECTIONS TO TB6 AS SHOWN FOR ENERGY MANAGEMENT BOARD OPTIONS. THE CONTACTS FOR OCCUPANCY OVERRIDE, DEMAND LIMIT AND ICE DONE OPTIONS MUST BE RATED FOR DRY CIRCUIT APPLICATION CAPABLE OF HANDLING A 24VAC LOAD UP TO 50 MA.
9. J3 - 24 AND 25 OF EMM BOARD ARE FOR RUN RELAY AND SHUTDOWN RELAY. THE MAXIMUM LOAD ALLOWED FOR THE RUN AND SHUTDOWN RELAY IS 10 VA SEALED, 25 VA INRUSH AT 24V. FIELD POWER SUPPLY IS NOT REQUIRED.

- A - ALARM
PMP1 - CHILLED WATER PUMP INTERLOCK
CWP - CHILLED WATER PUMP
EMM - ENERGY MANAGEMENT
SHD R - SHUTDOWN RELAY
RUN R - RUN RELAY
MLV - MINIMUM LOAD VALVE
TB - TERMINAL BLOCK
- - - FIELD POWER WIRING
- - - FIELD CONTROL WIRING

SIZE	STD UNIT
315A,B	160
330A	170
345A,B	170
360A	190
390A,B	190

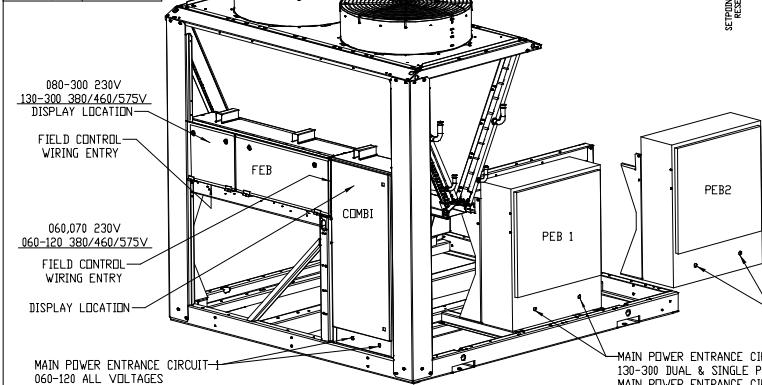

TYPICAL CONTROL BOX
AND MAIN POWER ENTRY

- 080-300 230V
130-300 380/460/575V
DISPLAY LOCATION
- 060,070 230V
060-120 380/460/575V
FIELD CONTROL WIRING ENTRY
- 060-120 230V
060-120 380/460/575V
FIELD CONTROL WIRING ENTRY
- DISPLAY LOCATION
- MAIN POWER ENTRANCE CIRCUIT 1
060-120 ALL VOLTAGES
130-190 DUAL & SINGLE POINT 208/230V
210-300 DUAL POINT 208/230V
MAIN POWER ENTRANCE CIRCUIT 2
060-120 DUAL POINT ALL VOLTAGES
130-190 DUAL POINT WITH DISCONNECT OPTION 380/460/575V
210,225 DUAL POINT WITH DISCONNECT OPTION 380/460/575V
- MAIN POWER ENTRANCE CIRCUIT 1
210-300 DUAL POINT, 208/230V
130-300 DUAL & SINGLE POINT, 380/460/575V
MAIN POWER ENTRANCE CIRCUIT 2
130-190 DUAL POINT, 208/230V
130-190 DUAL POINT WITH TERMINAL BLOCKS, 380/460/575V
210,225 DUAL POINT WITH TERMINAL BLOCKS, 380/460/575V

UNITED TECHNOLOGIES CARRIER P.O. BOX 4808 SYRACUSE, NY 13221
THIS DOCUMENT IS THE PROPERTY OF CARRIER CORPORATION AND IS DELIVERED UPON THE EXPRESS CONDITION THAT THE CONTENTS WILL NOT BE DISCLOSED OR USED WITHOUT CARRIER CORPORATION'S WRITTEN CONSENT.
SUBMISSION OF THESE DRAWINGS OR DOCUMENTS DOES NOT CONSTITUTE PART PERFORMANCE OR ACCEPTANCE OF CONTRACT.

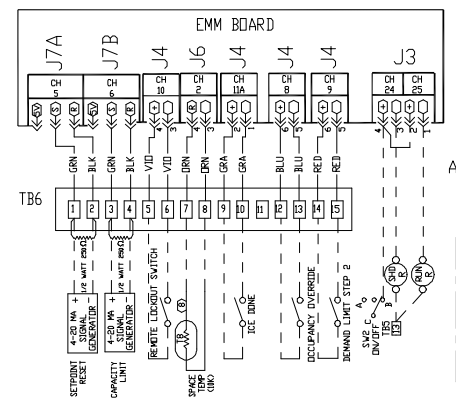
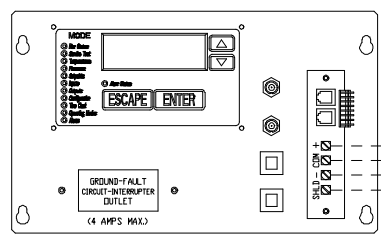

DATA COM PORT
EMM FIDP/ACCESSORY

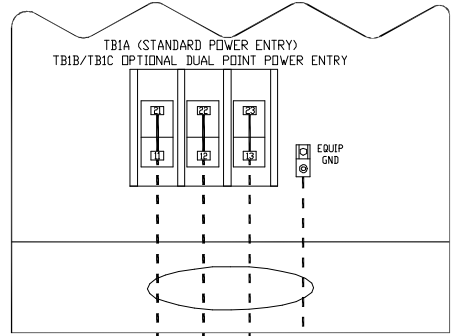
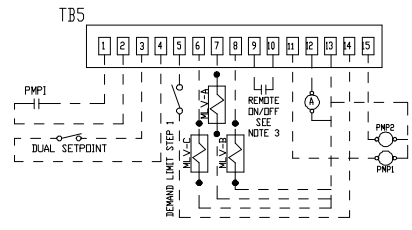
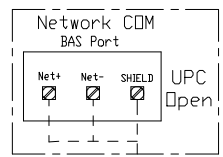

DISCONNECT / BRANCH
CIRCUIT
PROTECTION PER NEC
(SEE NOTE #5)

TERMINAL BLOCK

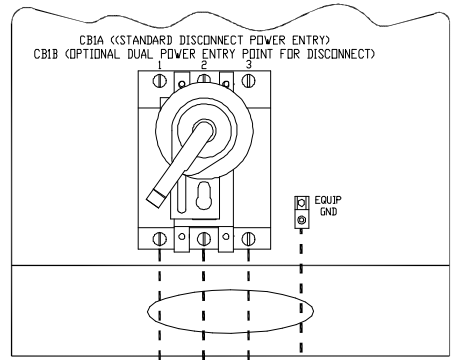

DISCONNECT / BRANCH
CIRCUIT
PROTECTION PER NEC
(SEE NOTE #5)

NON-FUSED DISCONNECT

DATE 06/10/10	SUPERCEDES 03/09/09	30RB060-390 AIR-COOLED AQUASNAP CHILLER	00DCN500001300A	REV G.2
------------------	------------------------	---	-----------------	------------

Summary Performance Report For Chiller 1 No Bacnet

Project: Wilco 350 Discovery Blvd
 Prepared By: Matt Walker

03/07/2019
 03:39PM



30RB with Greenspeed® Intelligence



Unit Information

Tag Name:..... **Chiller 1 No Bacnet**
 Model Number:..... **30RB130**
 Quantity:..... **1**
 Manufacturing Source:..... **Charlotte, NC USA**
 ASHRAE 90.1:..... **2013/2016, 2010, 2007**
 Refrigerant:..... **R-410A**
 Independent Refrigerant Circuits:..... **2**
 Shipping Weight:..... **7027** lb
 Operating Weight:..... **7402** lb
 Refrigerant Weight (Circuit A):..... **54** lb
 Refrigerant Weight (Circuit B):..... **43** lb
 Unit Length:..... **189** in
 Unit Width:..... **89** in
 Unit Height:..... **90** in

Accessories and Installed Options

Freeze Protection
 Suction Line Insulation
 Micro Channel
 Low Sound Option
 Single Point
 Coil Trim Panels
 Greenspeed Intelligence: High-Efficiency Variable Condenser Fans

Electrical Information

Unit Voltage:..... **460-3-60** V-Ph-Hz
 Connection Type:..... **Single Point**
 Minimum Voltage:..... **414** Volts
 Maximum Voltage:..... **506** Volts

Evaporator Information

Fluid Type:..... **Fresh Water**
 Fouling Factor:..... **0.000100** (hr-sqft-F)/BTU
 Leaving Temperature:..... **44.00** °F
 Entering Temperature:..... **54.00** °F
 Fluid Flow:..... **304.7** gpm
 Pressure Drop:..... **12.5** ft H2O

Amps	Electrical Circuit 1	Electrical Circuit 2
MCA	276.5	---
MOCP	300.0	---
ICF	484.5	---
Rec Fuse Size	300.0	---

Condenser Information

Altitude:..... **0.000** ft
 Number of Fans:..... **8**
 Total Condenser Fan Air Flow:..... **99,200** CFM
 Entering Air Temperature:..... **95.0** °F

Integrated Pump Information

No Pump Selected

Performance Information

Cooling Capacity:..... **127.4** Tons
 Total Compressor Power:..... **129.6** kW
 Total Fan Motor Power:..... **20.64** kW
 Total Unit Power (without pump):..... **150.2** kW
 Efficiency (without pump) (EER):..... **10.18** BTU/Wh
 IPLV:.IP:..... **16.81** BTU/Wh

An uncoated Novation condenser coil was selected for this product. This is based on an installed location with postal code 78701 and

Summary Performance Report For Chiller 1 No Bacnet

Project: Wilco 350 Discovery Blvd
Prepared By: Matt Walker

03/07/2019
03:39PM

a non-corrosive localized environment.
Sound power measured in accordance with ANSI/AHRI Standard 370-2015.



Certified in accordance with the AHRI Air-Cooled Water-Chilling Packages Certification Program, which is based on AHRI Standard 550/590 (I-P) and AHRI Standard 551/591 (SI). Certified units may be found in the AHRI Directory at www.ahridirectory.org.

Summary Performance Report For Chiller 1 No Bacnet

Project: Wilco 350 Discovery Blvd
 Prepared By: Matt Walker

03/07/2019
 03:39PM

Unit Parameters

Tag Name:..... **Chiller 1 No Bacnet**
 Model Number:..... **30RB130**
 Condenser Type:..... **Air Cooled**
 Compressor Type:..... **Scroll**
 Chiller Nameplate Voltage:..... **460-3-60** V-Ph-Hz
 Quantity:..... **1**
 Manufacturing Source:..... **Charlotte, NC USA**
 Refrigerant:..... **R-410A**
 Shipping Weight:..... **7027** lb
 Operating Weight:..... **7402** lb
 Refrigerant Weight (Circuit A):..... **54** lb
 Refrigerant Weight (Circuit B):..... **43** lb
 Unit Length:..... **189** in
 Unit Width:..... **89** in
 Unit Height:..... **90** in

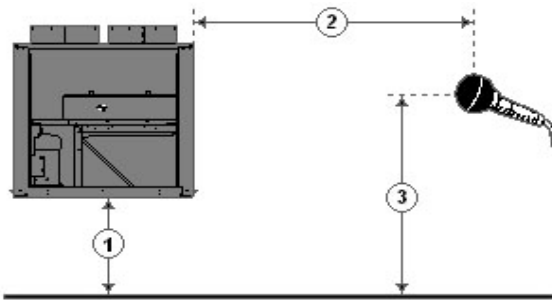

1 - Chiller Height Above Ground
 2 - Horizontal Distance From Chiller to Receiver
 3 - Receiver Height Above Ground
 (See Note 3)

Accessories and Installed Options

Freeze Protection	Single Point
Suction Line Insulation	Coil Trim Panels
Micro Channel	Greenspeed Intelligence: High-Efficiency Variable Condenser Fans
Low Sound Option	

Acoustic Information

Table 1. A-Weighted Sound Power Levels (dB re 1 picowatt). See note #1.

Octave Band Center Frequency, Hz	31	63	125	250	500	1k	2k	4k	8k	Overall
100% Load	41	70	83	89	94	98	93	89	81	101
75% Load	37	63	71	81	86	87	85	83	77	92
50% Load	37	64	68	78	82	84	82	79	75	89
25% Load	34	58	62	73	76	77	75	74	72	83

Table 2. A-Weighted Sound Pressure Levels (dB re 20 micropascals) calculated based upon user defined input for dimensions 1, 2 and 3 as shown in above diagram. See note #2 and #3.

Octave Band Center Frequency, Hz	31	63	125	250	500	1k	2k	4k	8k	Overall
100% Load	13	42	55	61	66	70	65	61	53	73
75% Load	9	35	43	53	58	59	57	55	49	64
50% Load	9	35	40	50	54	56	54	51	47	61
25% Load	6	29	34	45	48	49	47	46	44	55

Notes: (1) Measurements performed in accordance with AHRI Standard 370-2015 for air cooled Chillers.
 (2) Chiller is assumed to be a point source on a reflecting plane.
 (3) Without user defined input, the default dimensions used to construct Table 2 are as follows:
 1 - Chiller Height Above Ground = 0.0 ft
 2 - Horizontal Distance From Chiller to Receiver = 30.0 ft
 3 - Receiver Height Above Ground = 3.0 ft



GUIDE SPECIFICATIONS – 30RBX13064-LLG-3

HVAC Guide Specifications Outdoor Air-Cooled Liquid Chiller

Size: 130

Part 1: General

SYSTEM DESCRIPTION

- 1.01. Microprocessor controlled, air-cooled liquid chiller for outdoor installation, utilizing scroll compressors and low sound fans.
- 1.02. With the addition of Greenspeed intelligence, all fans are controlled with variable speed fan drive motors. Chiller software shall be specifically developed to coordinate optimal fan speed for application conditions and provide refrigerant circuit optimization, resulting in higher part-load efficiency and reduced acoustic levels.

QUALITY ASSURANCE

- 1.01. Unit shall be rated in accordance with AHRI (Air-Conditioning, Heating and Refrigeration Institute) Standard 550/590, latest edition (U.S.A.) and all units shall be ASHRAE (American Society of Heating, Refrigeration, and Air-Conditioning Engineers) 90.1 compliant.
- 1.02. Unit construction shall comply with ASHRAE 15 Safety Code, UL latest edition, and ASME (American Society of Mechanical Engineers) applicable codes (U.S.A. codes).
- 1.03. Unit shall be manufactured in a facility registered to ISO 9001 Manufacturing Quality Standard.
- 1.04. Unit shall be full load run tested at the factory.

DELIVERY, STORAGE AND HANDLING

- 1.01. Unit controls shall be capable of withstanding 150 F (66 C) storage temperatures in the control compartment.
- 1.02. Unit shall be stored and handled per unit manufacturer's recommendations.

Part 2: Products

EQUIPMENT

2.01. General:

- A. Factory assembled, single-piece chassis, air-cooled liquid chiller. Contained within the unit cabinet shall be all factory wiring, piping, controls, refrigerant charge (R-410A), and special features required prior to field start-up.

2.02. Unit Cabinet:

- A. Frame shall be of heavy-gage, painted galvanized steel.
- B. Cabinet shall be galvanized steel casing with a baked enamel powder or pre-painted finish.
- C. Cabinet shall be capable of withstanding 500-hour salt spray test in accordance with the ASTM (American Society for Testing and Materials) (U.S.A.) B-117 standard.

2.03. Fans:

- A. Condenser fans shall be direct-driven, VFD [variable frequency drive] controlled, 9-blade airfoil cross-section, reinforced polymer construction, shrouded-axial type, and shall be statically and dynamically balanced with inherent corrosion resistance.
- B. Air shall be discharged vertically upward.
- C. Fans shall be protected by coated steel wire safety guards.

Guide Specification for Chiller 1 No Bacnet

Project: Wilco 350 Discovery Blvd
Prepared By: Matt Walker

03/07/2019
03:39PM

2.04. Compressor/Compressor Assembly:

- A. Fully hermetic scroll type compressors.
- B. Direct drive, 3500 rpm (60 Hz), protected by motor temperature sensors, suction gas cooled motor.
- C. External vibration isolation rubber-in-shear.
- D. Each compressor shall be equipped with crankcase heaters to minimize oil dilution.

2.05. Cooler:

- A. Shell-and-tube type, direct expansion.
- B. Tubes shall be internally enhanced seamless-copper type rolled into tube sheets.
- C. Shall be equipped with Victaulic-type water connections.
- D. Shell shall be insulated with 3/4-in. (19-mm) PVC foam (closed-cell) with a maximum K factor of 0.28.
- E. Design shall incorporate a minimum of 2 independent direct-expansion refrigerant circuits.
- F. Cooler shall be tested and stamped in accordance with ASME Code for a refrigerant working side pressure of 445 psig (3068 kPa). Cooler shall have a maximum water-side pressure of 300 psig (2068 kPa).
- G. Cooler shall be provided with a factory-installed flow switch.

2.06. Condenser:

- A. Coil shall be air-cooled Novation® heat exchanger technology with microchannel (MCHX) coils and shall have a series of flat tubes containing a series of multiple, parallel flow microchannels layered between the refrigerant manifolds. Coils shall consist of a two-pass arrangement. Coil construction shall consist of aluminum alloys for fins, tubes, and manifolds in combination with a corrosion-resistant coating.
- B. Tubes shall be cleaned, dehydrated, and sealed.
- C. Assembled condenser coils shall be leak tested and pressure tested at 656 psig (4522 kPa).

2.07. Refrigeration Components:

- A. Refrigerant circuit components shall include replaceable-core filter drier, moisture indicating sight glass, electronic expansion device, discharge service valve and liquid line service valves, and complete operating charge of both refrigerant R-410A and compressor oil.

2.08. Controls, Safeties, and Diagnostics:

- A. Unit controls shall include the following minimum components:
 1. Microprocessor with non-volatile memory. Battery backup system shall not be accepted.
 2. Separate terminal block for power and controls.
 3. Control transformer to serve all controllers, relays, and control components.
 4. ON/OFF control switch.
 5. Replaceable solid-state controllers.
 6. Pressure sensors shall be installed to measure suction and discharge pressure. Thermistors shall be installed to measure cooler entering and leaving fluid temperatures as well as optional heat reclaim condenser entering and leaving fluid temperatures, and refrigerant pump down pressure and temperature.
- B. Unit controls shall include the following functions:
 1. Automatic circuit lead/lag.
 2. Hermetic scroll compressors are maintenance free and protected by an auto-adaptive control that minimizes compressor wear.
 3. Capacity control based on leaving chilled fluid temperature and compensated by rate of change of return-fluid temperature with temperature set point accuracy to 0.1° F (0.06° C).
 4. Limiting the chilled fluid temperature pull-down rate at start-up to an adjustable range of 0.2° F to 2° F (0.11° C to 1.1° C) per minute to prevent excessive demand spikes at start-up.
 5. Seven-day time schedule.
 6. Leaving chilled fluid temperature reset from return fluid and outside air temperature.
 7. Chilled water pump and optional heat reclaim condenser water pump start/stop control and primary/standby sequencing to ensure equal pump run time.
 8. Dual chiller control for parallel chiller applications without addition of hardware modules and control panels

Guide Specification for Chiller 1 No Bacnet

Project: Wilco 350 Discovery Blvd
Prepared By: Matt Walker

03/07/2019
03:39PM

(additional thermistors and wells are required).

9. Timed maintenance scheduling to signal maintenance activities for pumps, strainer maintenance and user-defined maintenance activities.
10. Low ambient protection to energize cooler and optional heat reclaim or hydronic system heaters.
11. Periodic pump start to ensure pump seals are properly maintained during off-season periods.
12. Single step demand limit control activated by remote contact closure.
13. Generation of 0 to 10 vdc signal to control 3-way valve position when optional heat reclaim is employed.
14. Nighttime sound mode to reduce the sound of the machine by a user-defined schedule.

C. Diagnostics:

1. The control panel shall include, as standard, a scrolling marquee display capable of indicating the safety lockout condition by displaying a code for which an explanation may be scrolled at the display with time and date stamp.
2. Information included for display shall be:
 - a. Compressor lockout.
 - b. Loss of charge.
 - c. Low fluid flow.
 - d. Cooler coil and optional heat reclaim coil freeze protection.
 - e. Cooler set point.
 - f. Optional heat reclaim set point.
 - g. Chilled water reset parameters.
 - h. Thermistor and transducer malfunction.
 - i. Entering and leaving-fluid temperature.
 - j. Evaporator and condenser pressure.
 - k. System refrigerant temperatures.
 - l. Chiller run hours.
 - m. Compressor run hours.
 - n. Compressor number of starts.
 - o. Time of day:
 - I) Display module, in conjunction with the microprocessor, must also be capable of displaying the output (results) of a service test. Service test shall verify operation of every switch, thermistor, fan, and compressor before chiller is started.
 - II) Diagnostics shall include the ability to review a list of the 30 most recent alarms with clear language descriptions of the alarm event. Display of alarm codes without the ability for clear language descriptions shall be prohibited.
 - III) An alarm history buffer shall allow the user to store no less than 30 alarm events with clear language descriptions, time and date stamp event entry.
 - IV) The chiller controller shall include multiple connection ports for communicating with the local equipment network, the Carrier Comfort Network® (CCN) system and access to chiller control functions from any point on the chiller.
 - V) The control system shall allow software upgrade without the need for new hardware modules.
 - p. Crankcase heater failure.

D. Safeties:

1. Unit shall be equipped with thermistors and all necessary components in conjunction with the control system to provide the unit with the following protections:
 - a. Loss of refrigerant charge.
 - b. Reverse rotation.
 - c. Low chilled fluid temperature.
 - d. Thermal overload.
 - e. High pressure.

Guide Specification for Chiller 1 No Bacnet

Project: Wilco 350 Discovery Blvd
Prepared By: Matt Walker

03/07/2019
03:39PM

- f. Electrical overload.
 - g. High heat reclaim leaving fluid temperature.
 - 2. Condenser fan and factory pump motors shall have external overcurrent protection.
- 2.09. Operating Characteristics:
 - A. Unit shall be capable of starting and running at outdoor ambient temperatures from 32 F to 125 F (0° to 52 C) for all sizes.
 - B. Unit shall be capable of starting up with 95 F (35 C) entering fluid temperature to the cooler.
- 2.10. Motors:
 - A. Condenser-fan motors shall be totally enclosed single-speed, 3-phase type with permanently lubricated bearings and Class F insulation.
- 2.11. Electrical Requirements:
 - A. Unit/module primary electrical power supply shall enter the unit at a single location (some chiller voltage/size combinations require 2 power supplies).
 - B. Unit shall operate on 3-phase power at the voltage shown in the equipment schedule.
 - C. Control points shall be accessed through terminal block.
 - D. Unit shall be shipped with factory control and power wiring installed.
- 2.12. Chilled Water Circuit:
 - A. Chilled water circuit shall be rated for 300 psig (2068 kPa).
- 2.13. Special Features:
 - A. High-efficiency variable condenser fans:
 - 1. All fans on the unit shall have variable speed fan motors to provide higher part load efficiency and reduced acoustic levels. Each fan circuit shall have a factory-installed, independent variable speed drive with display. Variable speed drives are rated IP-55 enclosures and UL Listed. The use of this option, with the addition of antifreeze in the cooler circuit and wind baffles, shall allow running with outdoor ambient temperatures down to -20 F (-28.9 C).
 - B. Condenser Coil Trim Panels:
 - 1. Unit shall be supplied with factory-installed coil covers and painted grilles to protect the condenser coil and internal chiller components from physical damage.
 - C. Security Grilles:
 - 1. Unit shall be supplied with factory-installed coil covers and painted grilles to protect the condenser coil and internal chiller components from physical damage.
 - D. Suction Line Insulation:
 - 1. Insulation shall be tubular closed-cell insulation. This option shall be required on applications with leaving fluid temperatures below 30 F (-1.1 C) and recommended for areas of high dewpoints where condensation may be a concern.
 - E. Freeze Protection Cooler Heaters:
 - 1. Cooler heaters shall provide protection from cooler freeze-up to -20 F (-29 C).
 - F. Compressor Sound Reduction:
 - 1. Shall provide sound reduction for the scroll compressors.
 - a. Unit shall be equipped with factory-installed option low sound - compressor sound reduction blanket which reduces unit sound levels by providing an acoustic blanket on each compressor.

Guide Specification for Chiller 1 No Bacnet

Project: Wilco 350 Discovery Blvd
Prepared By: Matt Walker

03/07/2019
03:39PM

DEWA Report not available for this configuration.

Detailed Performance Summary For Chiller 1 No Bacnet

Project: Wilco 350 Discovery Blvd
Prepared By: Matt Walker

03/07/2019
03:39PM



30RB with Greenspeed® Intelligence



Unit Information

Tag Name: **Chiller 1 No Bacnet**
Model Number: **30RB130**
Condenser Type: **Air Cooled**
Compressor Type: **Scroll**
Nameplate Voltage: **460-3-60** V-Ph-Hz
Quantity: **1**
Manufacturing Source: **Charlotte, NC USA**
ASHRAE 90.1: **2013/2016, 2010, 2007**
Refrigerant: **R-410A**
Capacity Control Steps: **6**
Minimum Capacity: **15.00** %
Shipping Weight: **7027** lb
Operating Weight: **7402** lb
Refrigerant Weight (Circuit A): **54** lb
Refrigerant Weight (Circuit B): **43** lb
Unit Length: **189** in
Unit Width: **89** in
Unit Height: **90** in
Minimum Outdoor Operating Temp: **-20.0** °F

Total Condenser Fan Air Flow: **99,200** CFM
Entering Air Temperature: **95.0** °F

Performance Information

Cooling Capacity: **127.4** Tons
Total Compressor Power: **129.6** kW
Total Fan Motor Power: **20.64** kW
Total Unit Power (without pump): **150.2** kW
Efficiency (without pump) (EER): **10.18** BTU/Wh

Evaporator Information

Fluid Type: **Fresh Water**
Fouling Factor: **0.000100** (hr-sqft-F)/BTU
Leaving Temperature: **44.00** °F
Entering Temperature: **54.00** °F
Fluid Flow: **304.7** gpm
Fluid Flow Min: **156.0** gpm
Fluid Flow Max: **624.0** gpm
Pressure Drop: **12.5** ft H2O

Condenser Information

Altitude: **0.000** ft
Number of Fans: **8**

Detailed Performance Summary For Chiller 1 No Bacnet

Project: Wilco 350 Discovery Blvd
 Prepared By: Matt Walker

03/07/2019
 03:39PM

Integrated Pump Information

No Pump Selected

Accessories and Installed Options

- Freeze Protection
- Suction Line Insulation
- Micro Channel
- Low Sound Option
- Single Point
- Coil Trim Panels
- Greenspeed Intelligence: High-Efficiency Variable Condenser Fans

Electrical Information

Unit Voltage:.....**460-3-60** V-Ph-Hz
 Connection Type:.....**Single Point**
 Minimum Voltage:.....**414** Volts
 Maximum Voltage:.....**506** Volts

Amps	Electrical Circuit 1	Electrical Circuit 2
MCA	276.5	---
MOCP	300.0	---
ICF	484.5	---
Rec Fuse Size	300.0	

Detailed Performance Summary For Chiller 1 No Bacnet

Project: Wilco 350 Discovery Blvd
 Prepared By: Matt Walker

03/07/2019
 03:39PM

Integrated Part Load Value (AHLI)

IPLV:.....**16.81** BTU/Wh

Unit Performance				
Percent of Full Load Capacity, %	100.00	75.00	50.00	25.00
Percent of Full Load Power, %	100.00	54.86	27.84	11.60
Unloading Sequence	B	B	B	B
Cooling Capacity, Tons	127.4	95.57	63.71	31.86
Total Unit Power, kW	150.2	82.39	41.81	17.42
Efficiency (EER), BTU/Wh	10.18	13.92	18.29	21.94
Evaporator Data				
Fluid Entering Temperature, °F	54.00	51.49	48.99	46.50
Fluid Leaving Temperature, °F	44.00	44.00	44.00	44.00
Fluid Flow Rate, gpm	304.7	304.7	304.7	304.7
Fouling Factor, (hr-sqft-F)/BTU	0.000100	0.000100	0.000100	0.000100
Condenser Data				
Entering Air Temperature, °F	95.0	80.0	65.0	55.0

An uncoated Novation condenser coil was selected for this product. This is based on an installed location with postal code 78701 and a non-corrosive localized environment.

Sound power measured in accordance with ANSI/AHRI Standard 370-2015.



Certified in accordance with the AHRI Air-Cooled Water-Chilling Packages Certification Program, which is based on AHRI Standard 550/590 (I-P) and AHRI Standard 551/591 (SI). Certified units may be found in the AHRI Directory at www.ahrirectory.org.

Detailed Performance Summary For Chiller 1 No Bacnet

Project: Wilco 350 Discovery Blvd
 Prepared By: Matt Walker

03/07/2019
 03:39PM

Unit Parameters

Tag Name:..... **Chiller 1 No Bacnet**
 Model Number:..... **30RB130**
 Condenser Type:..... **Air Cooled**
 Compressor Type:..... **Scroll**
 Chiller Nameplate Voltage:..... **460-3-60** V-Ph-Hz
 Quantity:..... **1**
 Manufacturing Source:..... **Charlotte, NC USA**
 Refrigerant:..... **R-410A**
 Shipping Weight:..... **7027** lb
 Operating Weight:..... **7402** lb
 Refrigerant Weight (Circuit A):..... **54** lb
 Refrigerant Weight (Circuit B):..... **43** lb
 Unit Length:..... **189** in
 Unit Width:..... **89** in
 Unit Height:..... **90** in

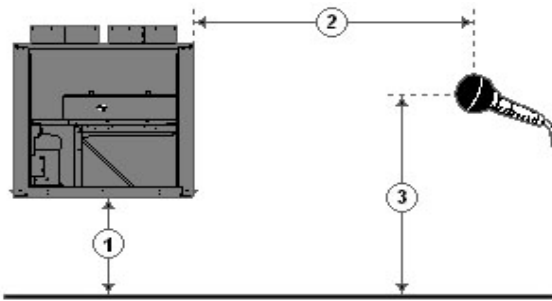

1 - Chiller Height Above Ground
 2 - Horizontal Distance From Chiller to Receiver
 3 - Receiver Height Above Ground
 (See Note 3)

Accessories and Installed Options

Freeze Protection	Single Point
Suction Line Insulation	Coil Trim Panels
Micro Channel	Greenspeed Intelligence: High-Efficiency Variable Condenser Fans
Low Sound Option	

Acoustic Information

Table 1. A-Weighted Sound Power Levels (dB re 1 picowatt). See note #1.

Octave Band Center Frequency, Hz	31	63	125	250	500	1k	2k	4k	8k	Overall
100% Load	41	70	83	89	94	98	93	89	81	101
75% Load	37	63	71	81	86	87	85	83	77	92
50% Load	37	64	68	78	82	84	82	79	75	89
25% Load	34	58	62	73	76	77	75	74	72	83

Table 2. A-Weighted Sound Pressure Levels (dB re 20 micropascals) calculated based upon user defined input for dimensions 1, 2 and 3 as shown in above diagram. See note #2 and #3.

Octave Band Center Frequency, Hz	31	63	125	250	500	1k	2k	4k	8k	Overall
100% Load	13	42	55	61	66	70	65	61	53	73
75% Load	9	35	43	53	58	59	57	55	49	64
50% Load	9	35	40	50	54	56	54	51	47	61
25% Load	6	29	34	45	48	49	47	46	44	55

Notes: (1) Measurements performed in accordance with AHRI Standard 370-2015 for air cooled Chillers.
 (2) Chiller is assumed to be a point source on a reflecting plane.
 (3) Without user defined input, the default dimensions used to construct Table 2 are as follows:
 1 - Chiller Height Above Ground = 0.0 ft
 2 - Horizontal Distance From Chiller to Receiver = 30.0 ft
 3 - Receiver Height Above Ground = 3.0 ft

Engineering Performance Report For Chiller 1 No Bacnet

Project: Wilco 350 Discovery Blvd
Prepared By: Matt Walker

03/07/2019
03:39PM



30RB with Greenspeed® Intelligence



Unit Information

Tag Name:..... **Chiller 1 No Bacnet**
Model Number:..... **30RB130**
Quantity:..... **1**
Manufacturing Source:..... **Charlotte, NC USA**
ASHRAE 90.1:..... **2013/2016, 2010, 2007**
Refrigerant:..... **R-410A**
Independent Refrigerant Circuits:..... **2**
Shipping Weight:..... **7027** lb
Operating Weight:..... **7402** lb
Refrigerant Weight (Circuit A):..... **54** lb
Refrigerant Weight (Circuit B):..... **43** lb
Unit Length:..... **189** in
Unit Width:..... **89** in
Unit Height:..... **90** in

Evaporator Information

Fluid Type:..... **Fresh Water**
Fouling Factor:..... **0.000100** (hr-sqft-F)/BTU
Fouling Factor Temp Adjustment:..... **0.39** °F
Leaving Temperature:..... **44.00** °F
Fouling Factor Adjustment:..... **43.61** °F
Entering Temperature:..... **54.00** °F
Fluid Flow:..... **304.7** gpm
Pressure Drop:..... **12.5** ft H2O

Condenser Information

Altitude:..... **0.000** ft
Number of Fans:..... **8**
Total Condenser Fan Air Flow:..... **99,200** CFM
Entering Air Temperature:..... **95.0** °F

Integrated Pump Information

No Pump Selected

Performance Information

Cooling Capacity:..... **127.4** Tons
Total Compressor Power:..... **129.6** kW
Total Fan Motor Power:..... **20.64** kW
Total Unit Power (without pump):..... **150.2** kW
Efficiency (without pump) (EER):..... **10.18** BTU/Wh
IPLV:..IP:..... **16.81** BTU/Wh

Engineering Performance Report For Chiller 1 No Bacnet

Project: Wilco 350 Discovery Blvd
Prepared By: Matt Walker

03/07/2019
03:39PM

Accessories and Installed Options

Freeze Protection
Suction Line Insulation
Micro Channel
Low Sound Option
Single Point
Coil Trim Panels
Greenspeed Intelligence: High-Efficiency Variable Condenser Fans

Connection Type:.....**Single Point**
Minimum Voltage:.....**414** Volts
Maximum Voltage:.....**506** Volts

Amps	Electrical Circuit 1	Electrical Circuit 2
MCA	276.5	---
MOCP	300.0	---
ICF	484.5	---
Rec Fuse Size	300.0	---

Electrical Information

Unit Voltage:.....**460-3-60** V-Ph-Hz

An uncoated Novation condenser coil was selected for this product. This is based on an installed location with postal code 78701 and a non-corrosive localized environment.

Sound power measured in accordance with ANSI/AHRI Standard 370-2015.



Certified in accordance with the AHRI Air-Cooled Water-Chilling Packages Certification Program, which is based on AHRI Standard 550/590 (I-P) and AHRI Standard 551/591 (SI). Certified units may be found in the AHRI Directory at www.ahridirectory.org.

Engineering Performance Report For Chiller 1 No Bacnet

Project: Wilco 350 Discovery Blvd
Prepared By: Matt Walker

03/07/2019
03:39PM

Unit Parameters

Tag Name:.....Chiller 1 No
Bacnet
Model Number:.....**30RB130**
Condenser Type:.....**Air Cooled**
Compressor Type:.....**Scroll**
Chiller Nameplate Voltage:.....**460-3-60** V-Ph-Hz
Quantity:.....**1**
Manufacturing Source:.....**Charlotte, NC USA**
Refrigerant:.....**R-410A**
Shipping Weight:.....**7027** lb
Operating Weight:.....**7402** lb
Refrigerant Weight (Circuit A):.....**54** lb
Refrigerant Weight (Circuit B):.....**43** lb
Unit Length:.....**189** in
Unit Width:.....**89** in
Unit Height:.....**90** in

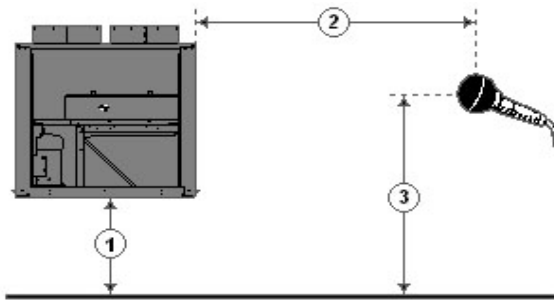

- 1 - Chiller Height Above Ground
- 2 - Horizontal Distance From Chiller to Receiver
- 3 - Receiver Height Above Ground
(See Note 3)

Accessories and Installed Options

Freeze Protection

Engineering Performance Report For Chiller 1 No Bacnet

Project: Wilco 350 Discovery Blvd
 Prepared By: Matt Walker

03/07/2019
 03:39PM

Suction Line Insulation
 Micro Channel
 Low Sound Option

Single Point
 Coil Trim Panels
 Greenspeed Intelligence: High-Efficiency Variable Condenser
 Fans

Acoustic Information

Table 1. A-Weighted Sound Power Levels (dB re 1 picowatt). See note #1.

Octave Band Center Frequency, Hz	31	63	125	250	500	1k	2k	4k	8k	Overall
100% Load	41	70	83	89	94	98	93	89	81	101
75% Load	37	63	71	81	86	87	85	83	77	92
50% Load	37	64	68	78	82	84	82	79	75	89
25% Load	34	58	62	73	76	77	75	74	72	83

Table 2. A-Weighted Sound Pressure Levels (dB re 20 micropascals) calculated based upon user defined input for dimensions 1, 2 and 3 as shown in above diagram. See note #2 and #3.

Octave Band Center Frequency, Hz	31	63	125	250	500	1k	2k	4k	8k	Overall
100% Load	13	42	55	61	66	70	65	61	53	73
75% Load	9	35	43	53	58	59	57	55	49	64
50% Load	9	35	40	50	54	56	54	51	47	61
25% Load	6	29	34	45	48	49	47	46	44	55

- Notes: (1) Measurements performed in accordance with AHRI Standard 370-2015 for air cooled Chillers.
 (2) Chiller is assumed to be a point source on a reflecting plane.
 (3) Without user defined input, the default dimensions used to construct Table 2 are as follows:
 1 - Chiller Height Above Ground = 0.0 ft
 2 - Horizontal Distance From Chiller to Receiver = 30.0 ft
 3 - Receiver Height Above Ground = 3.0 ft