

Agreement for Construction Services

This Agreement for Construction Services (“Agreement”) between Williamson County, Texas, a political subdivision of the State of Texas (“County”) and Aurelio Montes D/B/A Montes Construction (“Contractor”) is entered into in accordance with the following terms and conditions:

ARTICLE 1 PROJECT; WORK: The County desires to retain Contractor for the construction of an Onsite Sewage Facility (OSSF) at the Bridge Church, 747 CR 138, Hutto, Texas (hereinafter called the “Project”). The Contractor shall have the overall responsibility for and shall provide complete construction services and furnish all materials, equipment, tools and labor as necessary or reasonably inferable to complete the Project, or any phase of the Project, in accordance with the County’s requirements and the terms of this Agreement (hereinafter collectively referred to as the “Work”).

ARTICLE 2 CONTRACT PRICE: County agrees to pay to the Contractor, for the satisfactory performance of the Work, the sum of THIRTY-EIGHT THOUSAND EIGHT HUNDRED FIFTY DOLLARS (\$38,850.00) in accordance with the terms and conditions of this Agreement.

ARTICLE 3 SCOPE OF WORK, PLANS AND SPECIFICATIONS: The Work shall be performed pursuant to and in accordance with the following described scope of work, plans and specifications, being attached hereto and incorporated by reference, as well as any revisions made thereto:

- A. Scope of Work set forth in **Exhibit “A”**;
- B. Onsite Sewage Facility design, plans and specifications created and issued by Austin Best Septic, as set forth in **Exhibit “B”**; and
- C. Trench repair specifications and requirements pursuant to the City of Austin’s Trench Repair in Existing Pavement (UCM Section 5.7.4) (Standard No. 1100S-3A), as set forth in **Exhibit “C”**.

ARTICLE 4 COMPLETION: The Work shall be fully and finally completed within fifteen (15) calendar days from the date the Work is commenced; provided, however, County shall extend said time period in the event bad weather affects the progress of the Work. Contractor shall commence the Work upon instruction to do so from the Williamson County. County shall determine when the Project has been fully and finally completed to its satisfaction.

ARTICLE 5 PAYMENT: Contractor shall receive one lump sum payment of the Contract Price upon completion of the Project.

ARTICLE 6 CONTRACTOR’S GENERAL RESPONSIBILITIES AND COVENANTS:

6.1 Contractor shall render, diligently and competently in accordance with the highest standards used in the profession, all Contractor services which shall be necessary or advisable for the expeditious, economical and satisfactory completion of the Project. Contractor agrees to use its best efforts, skill, judgment, and abilities to perform its obligations and to further the interests of County in accordance with County’s requirements and procedures.

6.2 Contractor’s duties as set forth herein shall at no time be in any way diminished by reason of any approval by the County nor shall the Contractor be released from any liability by reason of such approval by the County, it being understood that the County at all times is ultimately relying upon the Contractor’s skill and knowledge in performing the services required hereunder.

6.3 Contractor is responsible for initiating, maintaining, and supervising all safety precautions and programs in connection with the Work. The safety program shall comply with all applicable requirements of the current federal Occupational Safety and Health Act and all other applicable federal, state and local laws and regulations.

6.4 Contractor shall be responsible for all construction means, methods, techniques, sequences and procedures, and for coordinating all portions of the Work. The Contractor shall keep the County informed of the progress and quality of the Work.

6.5 Insurance. Contractor shall carry insurance in the types and amounts indicated below for the duration of the Agreement, which shall include items owned by County in the care, custody and control of Contractor prior to and during construction. Contractor must also complete and file the declaration pages from the insurance policies with County whenever a previously identified policy period expires during the term of the Agreement, as proof of continuing coverage. Contractor shall update all expired policies prior to submission of any payment requests hereunder. Failure to update policies shall be reason for payment to be withheld until evidence for renewal is provided to the County.

6.5.1 The Contractor shall provide and maintain, until the Work covered in this Agreement is completed and accepted by the County, the minimum insurance coverage in the minimum amounts as described below. Coverage shall be written on an occurrence basis by companies authorized and admitted to do business in the State of Texas and rated A- or better by A.M. Best Company or otherwise acceptable to County.

Type of Coverage	Limits of Liability
a. Worker's Compensation	Statutory
b. Employer's Liability Bodily Injury by Accident	\$250,000 Ea. Accident

Bodily Injury by Disease	\$250,000 Ea. Employee
Bodily Injury by Disease	\$250,000 Policy Limit

- c. Comprehensive general liability including completed operations and contractual liability insurance for bodily injury, death, or property damages in the following amounts:

COVERAGE	PER PERSON	PER OCCURRENCE
Comprehensive General Liability <i>(including premises, completed operations and contractual)</i>	\$500,000	\$500,000
Aggregate policy limits:	\$500,000	

Comprehensive automobile and auto liability insurance (covering owned, hired, leased and non-owned vehicles):

COVERAGE	PER PERSON	PER OCCURRENCE
Bodily injury <i>(including death)</i>	\$500,000	\$500,000
Property damage	\$500,000	\$500,000
Aggregate policy limits	No aggregate limit	

Builder's Risk Insurance
(all risks)

An all-risks policy shall be in the amount equal at all times to 100% of the Contract Price. The policy shall include coverage for loss or damage caused by certified acts of terrorism as defined in the Terrorism Risk Insurance Act. The policy shall be issued in the name of the Contractor and shall name his Subcontractors as additional insureds. The County shall be named as a loss payee on the policy. The builders risk policy shall have endorsements as follow:

1. This insurance shall be specific as to coverage and not considered as contributing insurance with any permanent insurance maintained on the present premises. If off-site storage is permitted, coverage shall include transit and storage in an amount sufficient to protect property being transported or stored.
2. For renovation projects and or portions of work contained within an existing structure, the County waives subrogation

for damage by fire to existing building structure(s), if the Builder's Risk Policy has been endorsed to include coverage for existing building structure(s) in the amount described in the Special Conditions. However, Contractor shall not be required to obtain such an endorsement unless specifically required in this Agreement. The aforementioned waiver of subrogation shall not be effective unless such endorsement is obtained.

6.5.2 The above insurance requirements are not intended to be compounded with the Contractor's standing insurance policies. If the Contractor already has in force insurance policies which provide the required coverage, there is no need to purchase duplicate coverage for this project.

6.5.3 Policies must include the following clauses, as applicable.

- a. "This insurance shall not be canceled, limited in scope or coverage, or non-renewed until after thirty (30) days prior written notice, or ten (10) days for non-payment of premium, has been given to Williamson County."
- b. "It is agreed that the Contractor's insurance shall be deemed primary with respect to any insurance or self insurance carried by Williamson County for liability arising out of operations under the Agreement with Williamson County."
- c. "Williamson County, its officials, directors, employees, representatives, and volunteers are added as additional insured as respects operations and activities of, or on behalf of the named insured performed under Agreement with the County." This is not applicable to the workers' compensation policy.
- d. "The workers' compensation and employers' liability policy will provide a waiver of subrogation in favor of Williamson County."

6.5.4 Workers' Compensation Insurance Coverage:

In the event that Contractor employs any individual to perform any portion of the Work, Contractor shall comply with Texas Labor Code, §406.096, which requires workers' compensation insurance coverage for all employees providing services on a building or construction project for a governmental entity.

a. Definitions:

(1) Certificate of Coverage ("certificate") - A copy of a certificate of insurance, a certificate of authority to self-insure issued by the Texas Workers' Compensation Commission, or a coverage agreement (TWCC-81, TWCC-82, TWCC-83, or TWCC-84), showing statutory workers' compensation insurance coverage for the person's or entity's employees providing services on a project, for the Duration of the Work.

(2) Duration of the Work - includes the time from the beginning of the Work until the Work has been completed and accepted by the County.

(3) Coverage – Workers' compensation insurance meeting the statutory requirements of the Texas Labor Code, §401.011(44).

(4) Persons providing services relating to the Work ("subcontractor") - includes all persons or entities performing all or part of the services the Contractor has undertaken to perform the Work, regardless of whether that person contracted directly with the Contractor and regardless of whether that person has employees. This includes, without limitation, independent contractors, subcontractors, leasing companies, motor carriers, owner-operators, employees of any such entity, or employees of any entity which furnishes persons to provide services in relation to the Work. "Services" include, without limitation, providing, hauling, or delivering equipment or materials, or providing labor, transportation, or other service related to a project. "Services" does not include activities unrelated to the Work, such as food/beverage vendors, office supply deliveries, and delivery of portable toilets.

b. The Contractor shall provide Coverage, based on proper reporting of classification codes and payroll amounts and filing of any Coverage agreements, which meets the statutory requirements of Texas labor Code, §401.011(44) for all employees of the Contractor providing services in relation to the Work, for the Duration of the Work.

c. The Contractor must provide a Certificate of Coverage to the County prior to or contemporaneously with the execution of this Agreement.

d. If the Coverage period shown on the Contractor's current Certificate of Coverage ends during the Duration of the Work, the Contractor must, prior to the end of the Coverage period, file a new Certificate of Coverage with the County showing that Coverage has been extended.

e. The Contractor shall obtain from each person providing services in relation to the Work, and provide to the County:

(1) a Certificate of Coverage, prior to that person beginning any of the Work, so the County will have on file Certificates of Coverage showing Coverage for all persons providing services in relation to the Work; and

(2) no later than seven days after receipt by the Contractor, a new Certificate of Coverage showing extension of Coverage, if the Coverage period shown on the current Certificate of Coverage ends during the Duration of the Work.

f. The Contractor shall retain all required Certificates of Coverage for the Duration of the Work and for one year thereafter.

g. The Contractor shall notify the County in writing by certified mail or personal delivery, within 10 days after the Contractor knew or should have known, of any change that materially affects the provision of Coverage of any person providing services in relation to the Work.

h. The Contractor shall post on the Work site a notice, in the text, form and manner prescribed by the Texas Workers' Compensation Commission, informing all persons providing services in relation to the Work that they are required to be covered, and stating how a person may verify Coverage and report lack of Coverage.

i. By signing this Agreement or providing or causing to be provided a Certificate of Coverage, the Contractor is representing to the County that all employees of the Contractor who will provide services in relation to the Work and all persons providing services in relation to the Work will be covered by workers' compensation coverage for the Duration

of the Work, that the coverage will be based on proper reporting of classification codes and payroll amounts, and that all coverage agreements will be filed with the appropriate insurance carrier or, in the case of a self-insured, with the commission's Division of Self-Insurance Regulation. Providing false or misleading information may subject the Contractor to administrative penalties, criminal penalties, civil penalties, or other civil actions.

j. The Contractor's failure to comply with any of these provisions is a breach of Agreement by the Contractor which entitles the County to declare the Agreement void if the Contractor does not remedy the breach within ten (10) days after receipt of notice of breach from the County.

6.5.5 The furnishing of the above listed insurance coverage must be tendered prior to execution of the Agreement. The Contractor shall not cause or allow any of its required insurance to be canceled, nor permit any insurance to lapse during the term of the Agreement or as required in the Agreement. If the Contractor fails to obtain, maintain or renew any insurance required by this Agreement, the County may, among other remedies available hereunder or at law, obtain insurance coverage directly and recover the cost of that insurance from the Contractor or declare this Agreement void if the Contractor does not remedy the breach within ten (10) days after receipt of notice of breach from the County.

6.5.6 The County reserves the right to review the insurance requirements set forth in this Article during the effective period of the Agreement and to make reasonable adjustments to the insurance coverage and their limits when deemed necessary and prudent by the County based upon changes in statutory law, court decisions, or the claims history of the industry as well as the Contractor.

6.5.7 The County shall be entitled, upon request, and without expense, to receive complete copies of the policies with all endorsements and may make any reasonable requests for deletion, or revision or modification of particular policy terms, conditions, limitations, or exclusions, except where policy provisions are established by law or regulation binding upon the Parties or the underwriter of any of such policies. Damages caused by the Contractor and not covered by insurance shall be paid by the Contractor.

6.5.8 The Contractor shall contractually require each person or entity with whom it contracts to provide services in relation to the Work, to comply with each and every insurance requirement that Contractor must comply with hereunder. More specifically, each person or entity with whom Contractor contracts to provide services on the in relation to the Work must comply with each insurance requirement under this Article just as if such person or entity was the Contractor. Thus, every reference to Contractor under each insurance requirement of this Article shall mean and include each person or entity with whom Contractor contracts to provide services in relation to the Work. If any such person or entity with whom Contractor contracts to provide services in relation to the Work fails to obtain, maintain or renew any insurance required by this Agreement, the County may, among other remedies available hereunder or at law, obtain insurance coverage directly and recover the cost of that insurance from the Contractor or declare this Agreement void

if the Contractor does not remedy the breach within ten (10) days after receipt of notice of breach from the County.

ARTICLE 7 INDEMNITY

7.1 INDEMNIFICATION - EMPLOYEE PERSONAL INJURY CLAIMS. TO THE FULLEST EXTENT PERMITTED BY LAW, Contractor SHALL INDEMNIFY, DEFEND (WITH COUNSEL OF COUNTY'S CHOOSING), AND HOLD HARMLESS COUNTY, AND COUNTY'S EMPLOYEES, AGENTS, REPRESENTATIVES, PARTNERS, OFFICERS, AND DIRECTORS (COLLECTIVELY, THE "INDEMNITEES") AND SHALL ASSUME ENTIRE RESPONSIBILITY AND LIABILITY (OTHER THAN AS A RESULT OF INDEMNITEES' GROSS NEGLIGENCE) FOR ANY CLAIM OR ACTION BASED ON OR ARISING OUT OF THE PERSONAL INJURY, OR DEATH, OF ANY EMPLOYEE OF CONTRACTOR, OR OF ANY SUBCONTRACTOR, OR OF ANY OTHER ENTITY FOR WHOSE ACTS THEY MAY BE LIABLE, WHICH OCCURRED OR WAS ALLEGED TO HAVE OCCURRED ON THE PROJECT SITE OR IN CONNECTION WITH THE PERFORMANCE OF THE WORK. CONTRACTOR HEREBY INDEMNIFIES THE INDEMNITEES EVEN TO THE EXTENT THAT SUCH PERSONAL INJURY WAS CAUSED OR ALLEGED TO HAVE BEEN CAUSED BY THE SOLE, COMPARATIVE OR CONCURRENT NEGLIGENCE OF THE STRICT LIABILITY OF ANY INDEMNIFIED PARTY. THIS INDEMNIFICATION SHALL NOT BE LIMITED TO DAMAGES, COMPENSATION, OR BENEFITS PAYABLE UNDER INSURANCE POLICIES, WORKERS COMPENSATION ACTS, DISABILITY BENEFITS ACTS, OR OTHER EMPLOYEES BENEFIT ACTS.

INDEMNIFICATION - OTHER THAN EMPLOYEE PERSONAL INJURY CLAIMS. TO THE FULLEST EXTENT PERMITTED BY LAW, CONTRACTOR SHALL INDEMNIFY, DEFEND (WITH COUNSEL OF COUNTY'S CHOOSING), AND HOLD HARMLESS COUNTY, AND COUNTY'S EMPLOYEES, AGENTS, REPRESENTATIVES, PARTNERS, OFFICERS, AND DIRECTORS (COLLECTIVELY, THE "INDEMNITEES") FROM AND AGAINST CLAIMS, DAMAGES, LOSSES AND EXPENSES, INCLUDING BUT NOT LIMITED TO ATTORNEYS' FEES, ARISING OUT OF OR ALLEGED TO BE RESULTING FROM THE PERFORMANCE OF THIS AGREEMENT OR THE WORK DESCRIBED HEREIN, TO THE EXTENT CAUSED BY THE NEGLIGENCE, ACTS, ERRORS, OR OMISSIONS OF CONTRACTOR OR ITS SUBCONTRACTORS, ANYONE EMPLOYED BY THEM OR ANYONE FOR WHOSE ACTS THEY MAY BE LIABLE, REGARDLESS OF WHETHER OR NOT SUCH CLAIM, DAMAGE, LOSS OR EXPENSE IS CAUSED IN WHOLE OR IN PART BY A PARTY INDEMNIFIED HEREUNDER.

7.2 Except for the obligation of County to pay Contractor the Contract Price pursuant to the terms of this Agreement, and to perform certain other obligations pursuant to the terms and conditions explicitly set forth herein, County shall have no liability to Contractor or to anyone claiming through or under Contractor by reason of the execution or performance of this Agreement. Notwithstanding any obligation or liability of County to Contractor, no present or future partner or affiliate of County or any agent, officer, director, or employee of County, Williamson County, or of the various departments comprising Williamson County, or anyone claiming under County has or shall have any personal liability to Contractor or to anyone claiming through or under Contractor by reason of the execution or performance of this Agreement.

ARTICLE 8 WARRANTY

8.1 Contractor hereby warrants that the materials and equipment provided for the Work will be of good quality and new unless otherwise required or permitted by the County; that the

construction will be free from faults and defects; and that the construction will conform with the requirements of the plans, specifications, drawings and the terms of this Agreement.

8.2 Contractor shall provide warranty services for the Work for a full eighteen months following Final Completion and final payment. Just before the warranty period expires, Contractor shall attend an on-site meeting with the County to ensure that all warranty issues have been identified and properly remedied.

ARTICLE 9 MISCELLANEOUS PROVISIONS

9.1 Interest and Late Payments. County's payment for goods and services shall be governed by Chapter 2251 of the Texas Government Code. Interest charges for any overdue payments shall be paid by County in accordance with Texas Government Code Section 2251.025. More specifically, the rate of interest that shall accrue on a late payment is the rate in effect on September 1 of County's fiscal year in which the payment becomes due. The said rate in effect on September 1 shall be equal to the sum of one percent (1%); and (2) the prime rate published in the Wall Street Journal on the first day of July of the preceding fiscal year that does not fall on a Saturday or Sunday.

In the event that an error appears in an invoice/application for payment submitted by Contractor, County shall notify Contractor of the error not later than the twenty first (21st) day after the date County receives the invoice/application for payment. If the error is resolved in favor of Contractor, Contractor shall be entitled to receive interest on the unpaid balance of the invoice/application for payment submitted by Contractor beginning on the date that the payment for the invoice/application for payment became overdue. If the error is resolved in favor of the County, Contractor shall submit a corrected invoice/application for payment that must be paid in accordance within the time set forth above. The unpaid balance accrues interest as provided by Chapter 2251 of the Texas Government Code if the corrected invoice/application for payment is not paid by the appropriate date.

9.2 Audits. Contractor agrees that County or its duly authorized representatives shall, until the expiration of three (3) years after final payment under this Agreement, have access to and the right to examine and photocopy any and all books, documents, papers and records of Contractor which are directly pertinent to the services to be performed under this Agreement for the purposes of making audits, examinations, excerpts, and transcriptions. Contractor agrees that County shall have access during normal working hours to all necessary Contractor facilities and shall be provided adequate and appropriate workspace in order to conduct audits in compliance with the provisions of this section. County shall give Contractor reasonable advance notice of intended audits.

9.3 Assignment. This Agreement is a personal service contract for the services of Contractor, and Contractor's interest in this Agreement, duties hereunder and/or fees due hereunder may not be assigned or delegated to a third party.

9.4 Governing Law and Venue. This Agreement and all of the rights and obligations of the parties and all of the terms and conditions shall be construed, interpreted and applied in accordance

with and governed by and enforced under the laws of the State of Texas without reference to its conflicts of law provisions. Williamson County where the Project is located shall be the sole place of venue for any legal action arising from or related to this Agreement or the Project in which the County is a party.

9.5 Binding Effect. This Agreement shall be binding upon and inure to the benefit of the parties and their respective permitted assigns and successors.

9.6 Notices. All notices, consents, approvals, demands, requests or other communications relied on by the parties shall be in writing. Written notice shall be deemed to have been given when delivered in person to the designated representative of the Contractor or County for whom it is intended; or sent by U. S. Mail to the last known business address of the designated representative; or transmitted by fax machine to the last known business fax number of the designated representative. Mail notices are deemed effective upon receipt or on the third business day after the date of mailing, whichever is sooner. Fax notices are deemed effective the next business day after faxing.

9.7 Severability. Should any term or provision of this Agreement be held invalid or unenforceable in any respect, the remaining terms and provisions shall not be affected and this Agreement shall be construed as if the invalid or unenforceable term or provision had never been included.

9.8 Relationship of the Parties. Contractor shall be an independent contractor under this agreement and shall assume all of the rights, obligations, liabilities, applicable to it as such independent contractor hereunder and any provisions in this agreement which may appear to give County the right to direct Contractor as to details of doing the Work herein covered or to exercise a measure of control over the Work shall be deemed to mean that Contractor shall follow the desires of County in the results of the Work only. County shall not retain or have the right to control the Contractor's means, methods or details pertaining to the Contractor's performance of the Work described herein, nor shall County have the power to direct the order in which Contractor's Work is performed under this agreement. County and Contractor hereby agree and declare that Contractor is an Independent Contractor and as such meets the qualifications of an Independent Contractor under Texas Worker's Compensation Act, Texas Labor Code, Section 406.141, that the Contractor is not an employee of County for purposes of this Agreement, and that the Contractor and its employees, agents and sub-subcontractors shall not be entitled to worker's compensation coverage or any other type of insurance coverage held by County.

9.9 Force Majeure. If the party obligated to perform is prevented from performance by an act of war, order of legal authority, act of God, or other unavoidable cause not attributable to the fault or negligence of said party, the other party shall grant such party relief from the performance of this Agreement. The burden of proof for the need of such relief shall rest upon the party obligated to perform. To obtain release based on force majeure, the party obligated to perform shall file a written request with the other party.

9.10 No Waiver of Sovereign Immunity. Nothing herein shall be construed as a waiver of sovereign immunity by Williamson County.

9.11 Current Revenues. Under Texas law, a contract with a governmental entity that contains a claim against future revenues is void; therefore, each party paying for the performance of governmental functions or services must make those payments from current revenues available to the paying party.

9.12 Compliance with Laws. Contractor shall comply with all federal, state, and local laws, statutes, ordinances, rules and regulations, and the orders and decrees of any courts or administrative bodies or tribunals in any matter affecting the performance of this Agreement, including, without limitation, Worker's Compensation laws, minimum and maximum salary and wage statutes and regulations, licensing laws and regulations. When required, Contractor shall furnish the County with certification of compliance with said laws, statutes, ordinances, rules, regulations, orders, and decrees above specified.

9.13 Entire Agreement; Modifications. This Agreement supersedes all prior agreements, written or oral, between Contractor and County and shall constitute the entire Agreement and understanding between the parties with respect to the Project. This Agreement and each of its provisions shall be binding upon the parties and may not be waived, modified, amended or altered except by a writing signed by Contractor and County.

BY SIGNING BELOW, the Parties have executed and bound themselves to this Agreement to be effective as of the date of the last party's execution hereof.

OWNER:

WILLIAMSON COUNTY, TEXAS,
a political subdivision of the state of Texas

By: _____

Printed Name: _____

Title: _____

Date: _____

CONTRACTOR:

AURELIO MONTES D/B/A MONTES
CONSTRUCTION

By:  _____
Aurelio Montes

Date: Jan 6, 2022

EXHIBIT "A"

SCOPE OF WORK

Contractor shall perform the following:

1. Maintain the existing Onsite Sewage Facility functioning at all times during construction of the new Onsite Sewage Facility;
2. Installation of an Onsite Sewage Facility at Bridge Church, 747 CR 138, Hutto, Texas pursuant to the design, plans and specifications created and issued by Austin Best Septic, as set forth in **Exhibit "B"**;
3. Coordinate the connection of the new Onsite Sewage Facility with the property owner, Bridge Church, in order to minimize any impact to the property owner's ongoing daily operations;
4. Cut parking lot and haul off concrete and replace with 5" of concrete; and
5. As a part of the construction, perform standard trench repair that includes select bedding material, backfill/flex base and replacing concrete slab and perform saw cut joints at each location the trench crosses existing joints. All trench repairs shall be in accordance with the City of Austin's Trench Repair in Existing Pavement (UCM Section 5.7.4) (Standard No. 1100S-3A), as set forth in **Exhibit "C"**; provided, however, references made to HMAC Pavement and Tack Coat shall not be applicable to the Project.

EXHIBIT "B"

**ONSITE SEWAGE FACILITY DESIGN, PLANS AND SPECIFICATIONS
AUSTIN BEST SEPTIC**

CHURCH SURFACE APPLICATION OSSF

Site Evaluator Information: Name: Steve Gilmer
 County: Williamson County
 Company: Austin's Best Septic
 Address: 7916 Siringo Pass
 City: Austin
 State: TX
 Zip Code: 78749
 Cell: 512-680-1721
 Evaluated ~ June , 2021

Installer Information: Name: UNKNOWN, INSTALLER 2
 Phone:
 Address:
 City:
 State:
 Zip Code:

Legal Description: See title block

Soil Boring #	Depth (Inches)	Texture Class	Soil Texture	Structure/ gravel	Drainage (Redox/ Water Table)	Restrictive Horizon	Color	Observations
# 1	0-8"	IV	Clay	<30% gravel	No Evidence	No	Black	Unsuitable
	stopped							
# 2	0-8"	Class IV	Clay	<30% rock	No Evidence	No	Black	Unsuitable
	stopped							

Presence of upper watershed: No
 Presence of 100 year flood plain: No
 Organized Sewage Collection system available in area: No
 Waterwell in area: No
 In Edwards Aquifer Recharge zone: Yes
 Other sensitive features/ comments: No
 No Recharge Features observed within 150': No
 Suitable for Standard Type Systems: No
 Evidence of ground water: No

Suitable System Types:
 Conventional _____
 Leaching Chamber _____
 Evapotranspiration _____
 Low Pressure Dose _____
 Drip Irrigation _____
 Surface Application _____
 Mound _____
 Soil Substitution _____
 Other _____
 Owner selected surface application as affordable option

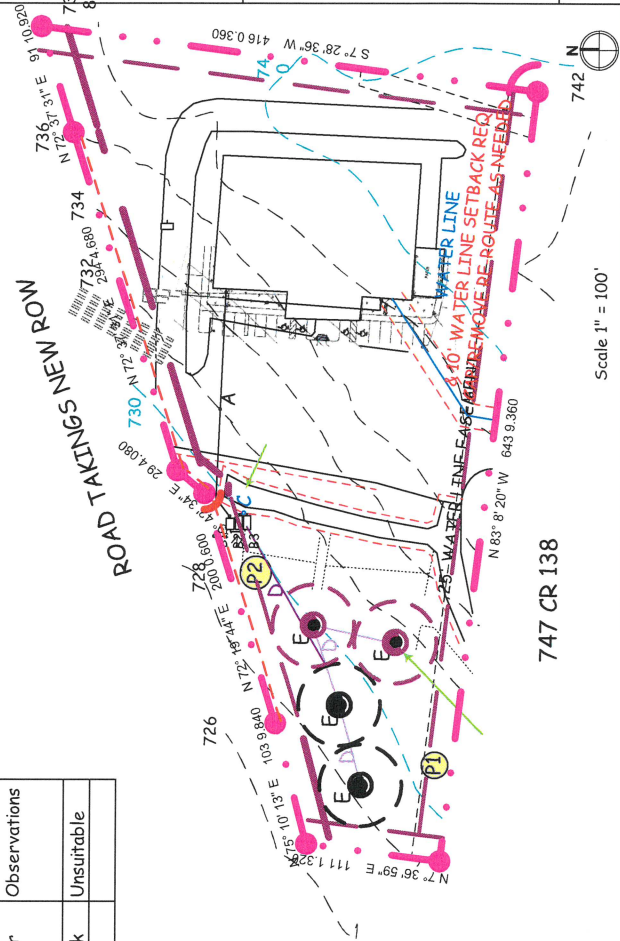

5/15/2021

Steve Gilmer
 PROFESSIONAL
 STATE OF TEXAS
 REG. NO. 9566
 austinbestseptic@yahoo.com

Austins Best Septi
 Steve Gilmer,
 OS9365, RS3506
 7916 Siringo Pass
 Austin, TX 78749
 (512) 680-1721

REVISIONS

NO.	DATE	DESCRIPTION

Checked X
 DRAWN 56

DATE ORIGINAL 5/15/2021
 SCALE
 JOB NO. 62115

LATEST REVISION

The Bridge Community Church
 Central Assembly of God
 Remainder of 73.35 Acres
 Survey, ABS 377
 (Road takings), 3.996 Acre, J. Kelsey

© 2021 Austins Best Septic, all rights reserved

EXHIBIT "C"

**CITY OF AUSTIN'S TRENCH REPAIR IN EXISTING PAVEMENT
(UCM SECTION 5.7.4) (STANDARD NO. 1100S-3A)**

TRENCH REPAIR IN EXISTING PAVEMENTS (UCM SECTION 5.7.4)

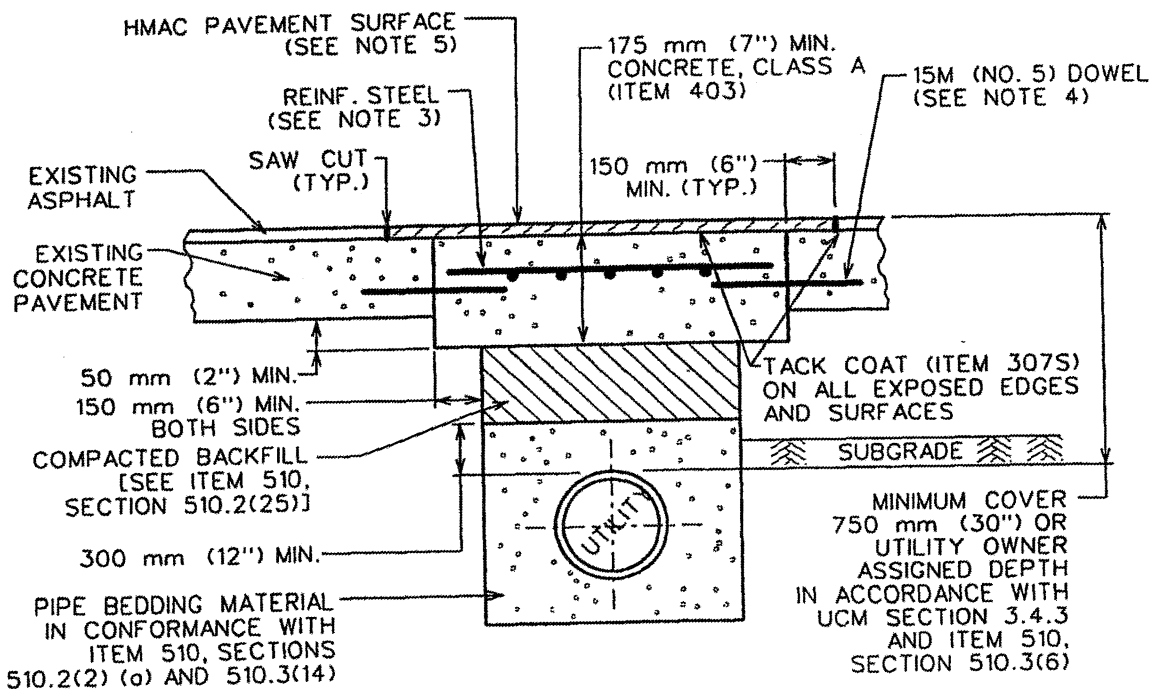

NOTES:

1. EXISTING PC NONREINFORCED CONCRETE SHALL BE SAW CUT TO A MINIMUM DEPTH OF 40 mm (1 1/2") AT A MINIMUM DISTANCE OF 150 mm (6") BACK OF THE VERTICAL WALL OF THE UTILITY TRENCH.
2. REPLACEMENT CONCRETE SHALL BE CLASS A AND SHALL MATCH EXISTING FINISH AND THICKNESS, BUT THE THICKNESS SHALL NOT BE LESS THAN 175 mm (7").
3. REINFORCING STEEL IN THE REPLACEMENT SLAB SHALL BE AT LEAST 15M (NO. 5) BARS. REINFORCING STEEL SHALL BE LAP SPLICED ACCORDING TO ITEM NO. 406. IF LENGTH OF LAP CAN NOT BE ACHIEVED, BARS SHALL BE WELDED A MINIMUM LENGTH OF 150 mm (6").
4. 15M (NO. 5) DOWELS SHALL BE INSTALLED AT 300 mm (12") ON CENTER FOR EXISTING PAVEMENT THICKNESSES 150 mm (6") OR GREATER.
5. REPLACEMENT AC SURFACE LAYER SHALL BE OF THE TYPE AND THICKNESS BASED ON FUNCTIONAL CLASSIFICATION.
 - a) MIN. 50 mm (2") HMAC TYPE "D" FOR TRENCH REPAIR IN LOCAL/RESIDENTIAL STREETS.
 - b) MIN. 75 mm (3") HMAC TYPE "C" FOR TRENCH REPAIR IN COLLECTOR/ARTERIAL STREETS.
 SEE ITEM 340, SECTION 340.3 (2).
6. CLASS "J" PC CONCRETE (ITEM 403) OR CONTROLLED LOW STRENGTH MATERIAL (CLSM) MAY BE SUBSTITUTED IN THESE REPAIRS FOR THE FLEXIBLE BASE AND COMPACTED BACKFILL. PC CPNCRETE GREATER THAN A 2 SACK MIX WILL NOT BE ALLOWED.

CITY OF AUSTIN DEPARTMENT OF PUBLIC WORKS	ASPHALT OVERLAY OF NONREINFORCED PC PAVEMENT-TRENCH REPAIR
<i>Leon Barba, P.E.</i> 5/5/03 ADOPTED	THE ARCHITECT/ENGINEER ASSUMES RESPONSIBILITY FOR APPROPRIATE USE OF THIS STANDARD.
	STANDARD NO. 1100S-3A