

Agreement for Construction Services (Cooperative Contract Buy Board 728-24)

This Agreement (“Agreement”) between Williamson County, Texas, a political subdivision of the State of Texas (“Owner”) and Falkenberg Construction Co., Inc. (“Contractor”) is entered into in accordance with the following terms and conditions:

ARTICLE 1 SCOPE OF WORK: The Owner desires to retain Contractor for the construction of Brushy Creek Regional Trail – Drainage Correction (hereinafter called the “Project”). The Contractor shall have the overall responsibility for and shall provide complete construction services and furnish all materials, equipment, tools and labor as necessary or reasonably inferable to complete the Project, or any phase of the Project, in accordance with the Owner’s requirements and the terms of this Agreement (hereinafter collectively referred to as the “Work”).

ARTICLE 2 CONTRACT PRICE: Owner agrees to pay to the Contractor, for the satisfactory performance of the Work, the sum of **One Hundred Sixty-Five Thousand Eight Hundred Thirty-Eight and 32/100 Dollars (\$165,838.32)** in accordance with the terms and conditions of this Agreement.

ARTICLE 3 PLANS AND SPECIFICATIONS: The Work shall be performed pursuant to and in accordance with the plans and specifications attached hereto as **Exhibit “A”**, as well as any revisions made thereto.

ARTICLE 4 CONTRACT TIME:

4.1 Contractor shall commence the Work upon instruction to do so from the Owner and shall achieve Substantial Completion within **one hundred (100) calendar days** from the date the Work is commenced; provided, however, Owner may extend said time period in the event bad weather affects the progress of the Work. Unless otherwise specified in writing, Contractor shall achieve Final Completion within **thirty (30) calendar days of Substantial Completion**. Owner shall determine when the Project has been fully and finally completed to its satisfaction. The time set forth for completion of the work is an essential element of the Agreement.

4.2 Liquidated Damages.

Contractor acknowledges and recognizes that Owner is entitled to full and beneficial occupancy and use of the completed Work following expiration of the Contract Time and that Owner has entered into, or will enter into, binding agreements upon Contractor's achieving Substantial

Completion of the Work within the Contract Time. Contractor further acknowledges and agrees that if Contractor fails to complete substantially or cause the Substantial Completion of any Phase of the Work within the Contract Time, Owner will sustain extensive damages and serious loss as a result of such failure. In the cases of missed scheduled events, which incur exact losses of revenue and exact expenses for fees and other cancellation costs, Contractor shall be responsible for the exact amount of damages sustained by Owner. In other cases, the exact amount of such damages will be extremely difficult to ascertain. Therefore, Owner and Contractor agree as set forth below:

- 4.2.1 Subject to the other terms and conditions herein, if Substantial Completion is not achieved by the date specified above or by such date to which the Contract Time may be extended, the Contract Price shall be reduced by **Five Hundred Dollars (\$500.) per calendar day** as liquidated damages and not as a penalty, until the date of Substantial Completion. Force majeure shall apply relative to both rain/snow delays (acts of nature) and/or supply delays over which Contractor has no control, and such force majeure delays shall not be subject to such reduction of the Contract Price.
- 4.2.2 Owner may deduct liquidated damages described herein from any unpaid amounts then or thereafter due Contractor under this Agreement. Any liquidated damages not so deducted from any unpaid amounts due Contractor shall be payable by Contractor to Owner at the demand of Owner, together with the interest from the date of the demand at a rate equal to the prime interest rate as published by the Wall Street Journal on the **first (1st) business day** after such amounts are demanded.
- 4.2.3 Notwithstanding anything to the contrary in this Agreement, if Owner is unable to recover any portion of liquidated damages in accordance with the terms and conditions herein because it is found to be unenforceable or invalid as a penalty or otherwise, then, Owner shall be entitled to recover from Contractor all of Owner's actual damages in connection with the failure by Contractor to achieve Substantial Completion of the Work within the Contract Time, including, without limitation, direct, indirect, or consequential damages.

ARTICLE 5 PAYMENT:

5.1 Schedule Of Values

Contractor shall submit to the Owner, before the first Application for Payment, a schedule of values allocating the entire Contract Price to the various portions of the Work and prepared in such form and supported by such data to substantiate its accuracy as the Owner may require. This schedule, unless objected to by the Owner, shall be used as a basis for reviewing the Contractor's Applications for Payment.

5.2 Applications For Payment

- 5.2.1 Contractor shall submit to the Owner an itemized Application for Payment prepared in accordance with the schedule of values for completed portions of the Work. Such application shall be notarized, if required, and supported by such data substantiating the Contractor's

right to payment as the Owner may require, such as copies of requisitions from subcontractors and material suppliers and shall reflect retainage if provided for in the Agreement.

5.2.1.1 Such applications may include requests for payment on account of changes in the Work that have been properly authorized by written Change Orders.

5.2.1.2 Applications for Payment shall not include requests for payment for portions of the Work for which the Contractor does not intend to pay a subcontractor or material supplier unless such Work has been performed by others whom the Contractor intends to pay.

5.2.1.3 If requested by Owner or required elsewhere in the Agreement, each Application for Payment shall be accompanied by the following, all in a form and substance satisfactory to the Owner:

- a. With each Application for Payment: a current Sworn Statement from the Contractor setting forth all subcontractors and all material suppliers with whom the Contractor has subcontracted, the amount of each such subcontract, the amount requested for any subcontractor or material supplier in the Application for Payment, and the amount to be paid to the Contractor from such progress payment;
- b. With each Application for Payment: a duly executed Conditional Waiver and Release on Progress Payment from the Contractor and subcontractors establishing receipt of payment or satisfaction of the payment requested by the Contractor in the current Application for Payment;
- c. Commencing with the second Application for Payment submitted by the Contractor, a duly executed Unconditional Waiver and Release on Progress Payment from Contractor and all subcontractors, material suppliers and, where appropriate, lower tier subcontractors that have billed more than five thousand dollars (\$5,000) on a single application of payment, establishing receipt of payment or satisfaction of payment of all amounts requested on behalf of such entities and disbursed prior to submittal by the Contractor of the current Application for Payment;
- d. With the Final Application for Payment: Contractor shall submit a Conditional Waiver and Release on Final Payment as required by Texas Property Code, §53.284. Upon receipt of final payment, Contractor shall submit an Unconditional Waiver and Release on Final Payment as required by Texas Property Code, §53.284; and
- e. Such other information, documentation, and materials as the Owner, or the title insurer (if any) may require in order to ensure that Owner's property is free of lien claims. Such other documents may include, without limitation, original copies of lien or bond claim releases suitable for filing with the County Clerk in Williamson County, Texas.

5.2.2 Unless otherwise provided in the Agreement, payments shall be made on account of materials and equipment delivered and suitably stored at the site for subsequent incorporation in the Work. If approved in advance by the Owner, payment may similarly be made for

materials and equipment suitably stored off the site at a location agreed upon in writing. Payment for materials and equipment stored on or off the site shall be conditioned upon compliance by the Contractor with procedures satisfactory to the Owner to establish the Owner's title to such materials and equipment or otherwise protect the Owner's interest, and shall include the costs of applicable insurance, storage and transportation to the site for such materials and equipment stored off the site.

5.2.3 The Contractor warrants that title to all Work covered by an Application for Payment will pass to the Owner no later than the time of payment. The Contractor further warrants that upon submittal of an Application for Payment all Work for which Certificates for Payment have been previously issued and payments received from the Owner shall, to the best of the Contractor's knowledge, information and belief, be free and clear of liens, bond claims, claims, security interests or encumbrances in favor of the Contractor, subcontractors, material suppliers, or other persons or entities making a claim by reason of having provided labor, materials and equipment relating to the Work.

5.2.3.1 The Contractor further expressly undertakes to defend Owner, at the Contractor's sole expense, against any actions, lawsuits, or proceedings brought against Owner as a result of liens filed against the Work, the site of any of the Work, the Project site and any improvements thereon, or any portion of the property of any of Owner (referred to collectively as "liens" in this paragraph), provided the Owner has paid Contractor pursuant to the requirements of the Agreement. The Contractor hereby agrees to indemnify and hold Owner harmless against any such liens or claims of lien and agrees to pay any judgment or lien resulting from any such actions, lawsuits, or proceedings.

5.2.3.2 The Owner shall release any payments withheld due to a lien or bond claims if the Contractor obtains security acceptable to the Owner, however, the Contractor shall not be relieved of any responsibilities or obligations under this paragraph, including, without limitation, the duty to defend and indemnify Owner.

5.2.3.3 Retainage. The Owner shall withhold from each progress payment, as retainage, five percent (5%) of the total earned amount. Retainage so withheld shall be managed in conformance with Texas Government Code, Chapter 2252, Subchapter B. Any request for reduction or release of retainage shall be accompanied by written consent of the Contractor's Surety. No such request shall be made until the Contractor has earned at least sixty-five percent (65%) of the total Contract Price.

5.2.3.4 For purposes of Texas Government Code, §2251.021 (a)(2), the date the performance of service is completed is the date when the Owner's representative approves the Application for Payment.

5.3 Certificates For Payment

5.3.1 The Owner will, within seven (7) business days after receipt of the Contractor's Application for Payment, issue a Certificate for Payment, with a copy to the Contractor, for such amount as the Owner determines is properly due, or notify the Contractor in writing of the Owner's

reasons for withholding certification in whole or in part as provided.

5.3.2 The issuance of a Certificate for Payment will constitute a representation by the Owner, based on the Owner's evaluation of the Work and the data comprising the Application for Payment, that, to the best of the Owner's knowledge, information and belief, the Work has progressed to the point indicated and that the quality of the Work is in accordance with the Agreement. The foregoing representations are subject to an evaluation of the Work for conformance with the Agreement upon Substantial Completion, to results of subsequent tests and inspections, to correction of minor deviations from the Agreement prior to completion and to specific qualifications expressed by the Owner. The issuance of a Certificate for Payment will further constitute a representation that the Contractor is entitled to payment in the amount certified. However, the issuance of a Certificate for Payment will not be a representation that the Owner has (1) made exhaustive or continuous on-site inspections to check the quality or quantity of the Work, (2) reviewed construction means, methods, techniques, sequences or procedures, (3) reviewed copies of requisitions received from subcontractors and material suppliers and other data requested by the Owner to substantiate the Contractor's right to payment, or (4) made examination to ascertain how or for what purpose the Contractor has used money previously paid on account of the Contract Price.

5.4 Decisions To Withhold Certification

5.4.1 The Owner may withhold a Certificate for Payment in whole or in part, to the extent reasonably necessary to protect the Owner, if in the Owner's opinion the representations to the Owner required herein cannot be made. If the Owner is unable to certify payment in the amount of the Application, the Owner will notify the Contractor. If the Contractor or Contractor and Owner, as the case may be, cannot agree on a revised amount, the Owner will promptly issue a Certificate for Payment for the amount that can be certified. The Owner may also withhold a Certificate for Payment or, because of subsequently discovered evidence, may nullify the whole or a part of a Certificate for Payment previously issued, to such extent as may be necessary in the Owner's opinion to protect the Owner from loss for which the Contractor is responsible because of:

5.4.1.1 defective Work not remedied;

5.4.1.2 third party claims filed or reasonable evidence indicating probable filing of such claims;

5.4.1.3 failure of the Contractor to make payments properly to subcontractors or for labor, materials or equipment;

5.4.1.4 reasonable evidence that the Work cannot be completed for the unpaid balance of the Contract Price;

5.4.1.5 damage to the Owner or a separate contractor;

5.4.1.6 failure to maintain the scheduled progress, or reasonable evidence that the Work will not be completed within the Contract Time;

5.4.1.7 failure to comply with the requirements of Texas Government Code, Chapter 2258 (Prevailing Wage Law);

5.4.1.8 failure to include sufficient documentation to support the amount of payment

requested for the Project;

5.4.1.9 failure to obtain, maintain, or renew insurance coverage, payment/performance bonds or warranty bond required by the Agreement; or

5.4.1.10 repeated failure to carry out the Work in accordance with the Agreement.

5.4.2 When the above reasons for withholding certification are removed, certification will be made for amounts previously withheld.

5.5 Progress Payments

5.5.1 The Owner shall make payment in the manner and within the time provided in the Agreement and in accordance with Texas Government Code, Chapter 2251.

5.5.2 The Contractor shall pay each subcontractor and material and equipment suppliers no later than ten (10) calendar days after receipt of payment from the Owner the amount to which the subcontractor or material and equipment suppliers is entitled. Payments to subcontractors may reflect the percentages actually retained from payments to the Contractor on account of the subcontractor's portion of the Work. The Contractor shall, by appropriate agreement with each subcontractor, require each subcontractor to make payments to Sub-subcontractors in a similar manner.

5.5.3 The Owner has the right to request written evidence from the Contractor that the Contractor has properly paid subcontractors and material and equipment suppliers amounts paid by the Owner to the Contractor for subcontracted Work. If the Contractor fails to furnish such evidence within seven (7) calendar days, the Owner shall have the right to contact subcontractors to ascertain whether they have been properly paid. The Owner shall not have an obligation to pay or to see to the payment of money to a subcontractor, except as may otherwise be required by law.

5.5.4 A Certificate for Payment, a progress payment, or partial or entire use or occupancy of the Project by the Owner shall not constitute acceptance of Work not in accordance with the Agreement.

5.6 Failure Of Payment

5.6.1 If the Owner is required to issue Certificates for Payment and, through no fault of the Contractor, the Owner fails to timely issue Certificates for Payment in the time permitted in the Agreement, or if the Owner does not pay the Contractor by the date established in the Agreement, then the Contractor may, upon twenty-one (21) business days written notice to the Owner, stop the Work until payment of the amount owing has been received.

5.6.2 If the Owner is entitled to reimbursement or payment from the Contractor under or pursuant to the Agreement, such payment shall be made promptly upon demand by the Owner. Notwithstanding anything contained in the Agreement to the contrary, if the Contractor fails to promptly make any payment due the Owner, or if the Owner incurs any costs and expenses to cure any default of the Contractor or to correct defective work, the Owner shall have an

absolute right to offset such amount against the Contract Price and may, in the Owner's sole discretion, elect either to (1) deduct an amount equal to that which the Owner is entitled from any payment then or thereafter due the Contractor from the Owner, or (2) issue a written notice to the Contractor reducing the Contract Price by an amount equal to that which the Owner is entitled.

5.7 Substantial Completion

- 5.7.1** Substantial Completion is the stage in the progress of the Work when the Work or designated portion thereof is sufficiently complete in accordance with the Agreement so that the Owner can occupy or utilize the Work for its intended use; provided, however, that as a condition precedent to Substantial Completion, the Owner has received all certificates of occupancy and any other permits, approvals, licenses, and other documents from any governmental authority having jurisdiction thereof necessary for the beneficial occupancy of the Project.
- 5.7.2** When the Contractor considers that the Work, or a portion thereof which the Owner agrees to accept separately, is substantially complete, the Contractor shall prepare and submit to the Owner a comprehensive list of items to be completed or corrected prior to final payment (punch list). Failure to include an item on the punch list does not alter the responsibility of the Contractor to complete all Work in accordance with the Agreement.
- 5.7.3** Upon receipt of the Contractor's punch list, the Owner will examine the Work to determine whether the Work or designated portion thereof is substantially complete. If the Owner's examination discloses any item, whether or not included on the Contractor's punch list, that is not sufficiently complete in accordance with the Agreement, the Contractor shall, before issuance of the Certificate of Substantial Completion, complete or correct such item upon notification by the Owner. In such case, the Contractor shall then submit a request for another examination by the Owner to determine Substantial Completion.
- 5.7.4** When the Work or designated portion thereof is substantially complete, the Owner will prepare a Certificate of Substantial Completion that shall establish the date of Substantial Completion, shall establish responsibilities of the Owner and Contractor for security, maintenance, heat, utilities, damage to the Work and insurance, and shall fix the time within which the Contractor shall finish all items on the list accompanying the Certificate. Unless otherwise provided, Contractor shall complete all items on the punch list within thirty (30) calendar days of Substantial Completion. Warranties required by the Agreement shall commence on the date of Substantial Completion of the Work or designated portion thereof unless otherwise provided in the Certificate of Substantial Completion.
- 5.7.5** The Certificate of Substantial Completion shall be submitted to the Owner and Contractor for their written acceptance of responsibilities assigned to them in such Certificate of Substantial Completion. Upon such acceptance and consent of surety, if any, the Owner shall

make payment of retainage.

5.8 Partial Occupancy or Use

- 5.8.1** The Owner may occupy or use any completed or partially completed portion of the Work at any stage when such portion is designated by separate agreement with the Contractor, provided such occupancy or use is consented to by the insurer, the surety, and authorized by public authorities having jurisdiction over the Project. Such partial occupancy or use may commence whether or not the portion is substantially complete, provided the Owner and Contractor have accepted in writing the responsibilities assigned to each of them for payments, retainage, if any, security, maintenance, heat, utilities, damage to the Work and insurance, and have agreed in writing concerning the period for correction of the Work and commencement of warranties required by the Agreement. When the Contractor considers a portion substantially complete, the Contractor shall prepare and submit a list to the Owner as provided herein. Consent of the Contractor to partial occupancy or use shall not be unreasonably withheld.
- 5.8.2** Immediately prior to partial occupancy or use, the Owner and Contractor shall jointly inspect the area to be occupied or portion of the Work to be used in order to determine and record the condition of the Work.
- 5.8.3** Partial occupancy or use of a portion or portions of the Work shall not constitute acceptance of Work not complying with the requirements of the Agreement.

5.9 Final Completion and Final Payment

- 5.9.1** Upon receipt of the Contractor's written notice that the Work is ready for final inspection and acceptance and upon receipt of a final Application for Payment, the Owner will make such inspection and, when the Owner finds the Work acceptable under the Agreement and the Agreement fully performed, the Owner will issue a final Certificate for Payment for the entire balance found to be due the Contractor and noted in the final Certificate is due and payable. All warranties and guarantees required under or pursuant to the Agreement shall be assembled and delivered by the Contractor to the Owner as part of the final Application for Payment. The final Certificate for Payment will not be issued by the Owner until all warranties and guarantees have been received and accepted by the Owner.
- 5.9.2** Neither final payment nor any remaining retained percentage shall become due until the Contractor submits to the Owner (1) an affidavit that payrolls, bills for materials and equipment, and other indebtedness connected with the Work have been paid or otherwise satisfied, within the period of time required by Texas Government Code, Chapter 2251, (2) a certificate evidencing that insurance required by the Agreement to remain in force after final payment is currently in effect and will not be canceled or allowed to expire until at least thirty (30) business days prior written notice has been given to the Owner, (3) a written statement that the Contractor knows of no substantial reason that the insurance will not be renewable to cover the period required by the Agreement, (4) consent of surety to final payment, (5) a warranty bond in a form acceptable to Owner, and (6) other data establishing

payment or satisfaction of obligations, such as receipts, unconditional full and final releases and waivers of liens, claims, security interests or encumbrances arising out of the Agreement, to the extent and in such form as may be designated by the Owner.

- 5.9.3** Acceptance of final payment by the Contractor, a subcontractor or material supplier shall constitute a waiver of claims by that payee except those previously made in writing and identified by that payee as unsettled at the time of final Application for Payment.

ARTICLE 6 CONTRACTOR'S GENERAL RESPONSIBILITIES AND COVENANTS:

6.1 Contractor shall render, diligently and competently in accordance with the highest standards used in the profession, all Contractor services which shall be necessary or advisable for the expeditious, economical and satisfactory completion of the Project. Contractor agrees to use its best efforts, skill, judgment, and abilities to perform its obligations and to further the interests of Owner in accordance with Owner's requirements and procedures.

6.2 Contractor's duties as set forth herein shall at no time be in any way diminished by reason of any approval by the Owner nor shall the Contractor be released from any liability by reason of such approval by the Owner, it being understood that the Owner at all times is ultimately relying upon the Contractor's skill and knowledge in performing the services required hereunder.

6.3 Contractor is responsible for initiating, maintaining, and supervising all safety precautions and programs in connection with the Work. The safety program shall comply with all applicable requirements of the current federal Occupational Safety and Health Act and all other applicable federal, state and local laws and regulations.

6.4 Contractor shall be responsible for all construction means, methods, techniques, sequences and procedures, and for coordinating all portions of the Work. The Contractor shall keep the Owner informed of the progress and quality of the Work.

6.5 Insurance. Contractor shall carry insurance in the types and amounts indicated below for the duration of the Agreement, which shall include items owned by Owner in the care, custody and control of Contractor prior to and during construction. Contractor must also complete and file the declaration pages from the insurance policies with Owner whenever a previously identified policy period expires during the term of the Agreement, as proof of continuing coverage. Contractor shall update all expired policies prior to submission of any payment requests hereunder. Failure to update policies shall be reason for payment to be withheld until evidence for renewal is provided to the Owner. If the Contractor fails to obtain, maintain or renew any insurance required by this Agreement, the Owner may, among other remedies available hereunder or at law, obtain insurance coverage directly and recover the cost of that insurance from the Contractor or declare this Agreement void if the Contractor does not remedy the breach within ten (10) days after receipt of notice of breach from the Owner. All policies of insurance provided by the Contractor must comply with the requirements set forth herein, the Agreement and the laws of the State of Texas.

6.5.1 The Contractor shall provide and maintain, until the Work covered in the Agreement is completed and accepted by the Owner, the minimum insurance coverages in the minimum amounts as described below.

	Type of Coverage	Limits of Liability
.1	Worker's Compensation	Statutory
.2	Employer's Liability	
	Bodily Injury by Accident	\$500,000 Ea. Accident
	Bodily Injury by Disease	\$500,000 Ea. Employee
	Bodily Injury by Disease	\$500,000 Policy Limit

.3 Commercial general liability including completed operations and contractual liability insurance for bodily injury, death, or property damages in the following amounts:

COVERAGE	PER OCCURRENCE
Commercial General Liability (including premises, completed operations and contractual)	\$1,000,000
Aggregate policy limits:	\$2,000,000

.4 Comprehensive automobile and auto liability insurance (covering owned, hired, leased and non-owned vehicles):

COVERAGE	PER PERSON	PER OCCURRENCE
Bodily injury (including death)	\$1,000,000	\$1,000,000
Property damage	\$1,000,000	\$1,000,000
Aggregate policy limits	No aggregate limit	

.5 Builder's Risk Insurance (all-risks)

An all-risk policy, in the amount equal at all times to 100% of the Contract Price. The policy shall include coverage for loss or damage caused by certified acts of terrorism as defined in the Terrorism Risk Insurance Act. The policy shall be issued in the name of the Contractor and shall name its Subcontractors as additional

insureds. The Owner shall be named as a loss payee on the policy. The builders risk policy shall have endorsements as follow:

- a. This insurance shall be specific as to coverage and not considered as contributing insurance with any permanent insurance maintained on the present premises. If off-site storage is permitted, coverage shall include transit and storage in an amount sufficient to protect property being transported or stored.
 - b. For renovation projects and or portions of work contained within an existing structure, the Owner waives subrogation for damage by fire to existing building structure(s), if the Builder's Risk Policy has been endorsed to include coverage for existing building structure(s) in the amount described in the Special Conditions. However, Contractor shall not be required to obtain such an endorsement unless specifically required by the Special Conditions, if any. The aforementioned waiver of subrogation shall not be effective unless such endorsement is obtained.
- .6. Flood insurance when specified in Supplementary General Conditions or Special Conditions.
- .7. Umbrella coverage in the amount of not less than \$5,000,000.

6.5.2 Workers' Compensation Insurance Coverage:

1. Definitions:
 - (a) Certificate of coverage ("certificate") - A copy of a certificate of insurance, a certificate of authority to self-insure issued by the Texas Workers' Compensation Commission, or a coverage agreement (TWCC-81, TWCC-82, TWCC-83, or TWCC-84), showing statutory workers' compensation insurance coverage for the person's or entity's employees providing services on a project, for the duration of the Project.
 - (b) Duration of the Project - includes the time from the beginning of the work on the Project until the Contractor's/person's work on the Project has been completed and accepted by the Owner.
 - (c) Coverage – Workers' compensation insurance meeting the statutory requirements of the Texas Labor Code, §401.011(44).
 - (d) Persons providing services on the Project ("subcontractor") - includes all persons or entities performing all or part of the services the Contractor has undertaken to perform on the Project, regardless of whether that person contracted directly with the Contractor and regardless of whether that person has employees. This includes, without limitation, independent contractors, subcontractors, leasing companies, motor carriers, owner-operators, employees of any such entity, or employees of any entity which furnishes persons to provide services on the Project. "Services" include, without limitation, providing, hauling, or delivering equipment or materials, or providing labor, transportation, or other service related to a project.

"Services" does not include activities unrelated to the Project, such as food/beverage vendors, office supply deliveries, and delivery of portable toilets.

2. The Contractor shall provide coverage, based on proper reporting of classification codes and payroll amounts and filing of any coverage agreements, which meets the statutory requirements of Texas Labor Code, §401.011(44) for all employees of the Contractor providing services on the Project, for the duration of the Project.
3. The Contractor must provide a certificate of coverage prior to execution of the Agreement/Contract, and in no event later than ten (10) days from Notice of Award. Failure to provide the insurance in a timely fashion may result in loss of Contractor's bid bond.
4. If the coverage period shown on the Contractor's current certificate of coverage ends during the duration of the Project, the Contractor must, prior to the end of the coverage period, file a new certificate of coverage with the Owner showing that coverage has been extended.
5. The Contractor shall obtain from each person providing services on a project, and provide to the Owner:
 - (a.) a certificate of coverage, prior to that person beginning work on the Project, so the Owner will have on file certificates of coverage showing coverage for all persons providing services on the Project; and
 - (b.) no later than seven days after receipt by the Contractor, a new certificate of coverage showing extension of coverage, if the coverage period shown on the current certificate of coverage ends during the duration of the Project.
6. The Contractor shall retain all required certificates of coverage for the duration of the Project and for one year thereafter.
7. The Contractor shall notify the Owner in writing by certified mail or personal delivery, within 10 days after the Contractor knew or should have known, of any change that materially affects the provision of coverage of any person providing services on the Project.
8. The Contractor shall post on each project site a notice, in the text, form and manner prescribed by the Texas Workers' Compensation Commission, informing all persons providing services on the Project that they are required to be covered, and stating how a person may verify coverage and report lack of coverage.
9. The Contractor shall contractually require each person with who it contracts to provide services on a project, to:
 - (a) provide coverage, based on proper reporting of classification codes and payroll amounts and filing of any coverage agreements, which meets the statutory requirements of Texas labor Code, Section 401.011(44) for all of its employees providing services on the Project, for the duration of the Project;
 - (b) provide to the Contractor, prior to that person beginning work on the Project, a certificate of coverage showing that coverage is being provided for all

employees of the person providing services on the Project, for the duration of the Project;

(c) provide the Contractor, prior to the end of the coverage period, a new certificate of coverage showing extension of coverage, if the coverage period shown on the current certificate of coverage ends during the duration of the Project;

(d) obtain from each other person with whom it contracts, and provide to the Contractor:

i. a certificate of coverage, prior to the other person beginning work on the Project; and

ii. a new certificate of coverage showing extension of coverage, prior to the end of the coverage period, if the coverage period shown on the current certificate of coverage ends during the duration of the Project;

(e) retain all required certificate of coverage on file for the duration of the Project and for one year thereafter;

(f) notify the Owner in writing by certified mail or personal delivery, within 10 days after the person knew or should have known, of any change that materially affects the provision of coverage of any person providing services on the Project; and

(g) contractually require each person with whom it contracts, to perform as required by paragraphs (a)-(g), with the certificates of coverage to be provided to the person for whom they are providing services.

10. By signing the Agreement/Contract or providing or causing to be provided a certificate of coverage, the Contractor is representing to the Owner that all employees of the Contractor who will provide services on the Project will be covered by workers' compensation coverage for the duration of the Project, that the coverage will be based on proper reporting of classification codes and payroll amounts, and that all coverage agreements will be filed with the appropriate insurance carrier or, in the case of a self-insured, with the Commission's Division of Self-Insurance Regulation. Providing false or misleading information may subject the Contractor to administrative penalties, criminal penalties, civil penalties, or other civil actions.

11. The Contractor's failure to comply with any of these provisions is a breach of contract by the Contractor which entitles the Owner to declare the Agreement/Contract void if the Contractor does not remedy the breach within ten days after receipt of notice of breach from the Owner.

6.5.3 If insurance policies are not written for the amounts specified herein, Contractor shall carry Umbrella or Excess Liability Insurance for any differences in amounts specified. If Excess Liability Insurance is provided, it shall follow the form of primary coverage.

6.5.4 Insurance coverage required hereunder shall be written on an occurrence basis by companies authorized and admitted to do business in the State of Texas and rated A- or better by A.M. Best Company, or otherwise acceptable to Owner.

- 6.5.5** The Owner (“Williamson County, Texas”), its officials, employees and volunteers shall be named as an additional insured on all required policies. These insurance policies shall contain the appropriate additional insured endorsement signed by a person authorized by that insurer to bind coverage on its behalf.
- 6.5.6** The furnishing of the above listed insurance coverage, as may be modified by the Agreement, must be tendered prior to execution of the Agreement/Contract, and in no event later than ten (10) days from Notice of Award. Failure to provide the insurance in a timely fashion may result in loss of Contractor’s bid bond.
- 6.5.7** Owner reserves the right to review the insurance requirements set forth herein during the Agreement and to make reasonable adjustments to the insurance coverage and their limits when deemed necessary and prudent by the Owner based upon changes in statutory law, court decisions, or the claims history of the industry as well as the Contractor.
- 6.5.8** Owner shall be entitled, upon request, and without expense, to receive complete copies of the policies with all endorsements and may make any reasonable requests for deletion, or revision or modification of particular policy terms, conditions, limitations, or exclusions, except where policy provisions are established by law or regulation binding upon the Parties or the underwriter of any of such policies. Damages caused by the Contractor and not covered by insurance shall be paid by the Contractor.
- 6.5.9** Contractor shall be responsible for payment of premiums for all of the insurance coverages required hereunder. Contractor further agrees that for each claim, suit or action made against insurance provided hereunder, with respect to all matters for which the Contractor is responsible hereunder, Contractor shall be solely responsible for all deductibles and self-insured retentions. Any deductibles or self-insured retentions over \$75,000 in the Contractor’s insurance must be declared and approved in writing by Owner in advance.
- 6.5.10** Contractor shall contractually require each person or entity with whom it contracts to provide services in relation to the Work, to comply with every insurance requirement that Contractor must comply with hereunder. More specifically, each person or entity with whom Contractor contracts to provide services on the in relation to the Work must comply with each insurance requirement hereunder just as if such person or entity was the Contractor. Thus, every reference to Contractor under each insurance requirement hereunder shall mean and include each person or entity with whom Contractor contracts to provide services in relation to the Work. If any such person or entity with whom Contractor contracts to provide services in relation to the Work fails to obtain, maintain or renew any insurance required by this Agreement, Owner may, among other remedies available hereunder or at law, obtain insurance coverage directly and recover the cost of that insurance from the Contractor or declare this Agreement void if the Contractor does not remedy the breach within ten (10) days after receipt of notice of breach from the Owner.

ARTICLE 7 INDEMNITY:

7.1 INDEMNIFICATION - EMPLOYEE PERSONAL INJURY CLAIMS. TO THE FULLEST EXTENT PERMITTED BY LAW, Contractor SHALL INDEMNIFY, DEFEND (WITH COUNSEL OF OWNER’S CHOOSING), AND HOLD HARMLESS OWNER, AND OWNER’S EMPLOYEES, AGENTS, REPRESENTATIVES, PARTNERS, OFFICERS, AND DIRECTORS (COLLECTIVELY, THE “INDEMNITEES”) AND SHALL ASSUME ENTIRE RESPONSIBILITY AND LIABILITY (OTHER THAN AS A RESULT OF INDEMNITEES’ GROSS NEGLIGENCE) FOR ANY CLAIM OR ACTION BASED ON OR ARISING OUT OF THE PERSONAL INJURY, OR DEATH, OF ANY EMPLOYEE OF CONTRACTOR, OR OF ANY SUBCONTRACTOR, OR OF ANY OTHER ENTITY FOR WHOSE ACTS THEY MAY BE LIABLE, WHICH OCCURRED OR WAS ALLEGED TO HAVE OCCURRED ON THE PROJECT SITE OR IN CONNECTION WITH THE PERFORMANCE OF THE WORK. CONTRACTOR HEREBY INDEMNIFIES THE INDEMNITEES EVEN TO THE EXTENT THAT SUCH PERSONAL INJURY WAS CAUSED OR ALLEGED TO HAVE BEEN CAUSED BY THE SOLE, COMPARATIVE OR CONCURRENT NEGLIGENCE OR THE STRICT LIABILITY OF ANY INDEMNIFIED PARTY. THIS INDEMNIFICATION SHALL NOT BE LIMITED TO DAMAGES, COMPENSATION, OR BENEFITS PAYABLE UNDER INSURANCE POLICIES, WORKERS COMPENSATION ACTS, DISABILITY BENEFITS ACTS, OR OTHER EMPLOYEES BENEFIT ACTS.

INDEMNIFICATION - OTHER THAN EMPLOYEE PERSONAL INJURY CLAIMS. TO THE FULLEST EXTENT PERMITTED BY LAW, CONTRACTOR SHALL INDEMNIFY, DEFEND (WITH COUNSEL OF OWNER’S CHOOSING), AND HOLD HARMLESS OWNER, AND OWNER’S EMPLOYEES, AGENTS, REPRESENTATIVES, PARTNERS, OFFICERS, AND DIRECTORS (COLLECTIVELY, THE “INDEMNITEES”) FROM AND AGAINST CLAIMS, DAMAGES, LOSSES AND EXPENSES, INCLUDING BUT NOT LIMITED TO ATTORNEYS’ FEES, ARISING OUT OF OR ALLEGED TO BE RESULTING FROM THE PERFORMANCE OF THIS AGREEMENT OR THE WORK DESCRIBED HEREIN, TO THE EXTENT CAUSED BY THE NEGLIGENCE, ACTS, ERRORS, OR OMISSIONS OF CONTRACTOR OR ITS SUBCONTRACTORS, ANYONE EMPLOYED BY THEM OR ANYONE FOR WHOSE ACTS THEY MAY BE LIABLE, REGARDLESS OF WHETHER OR NOT SUCH CLAIM, DAMAGE, LOSS OR EXPENSE IS CAUSED IN WHOLE OR IN PART BY A PARTY INDEMNIFIED HEREUNDER.

7.2 Except for the obligation of Owner to pay Contractor the Contract Price pursuant to the terms of this Agreement, and to perform certain other obligations pursuant to the terms and conditions explicitly set forth herein, Owner shall have no liability to Contractor or to anyone claiming through or under Contractor by reason of the execution or performance of this Agreement. Notwithstanding any obligation or liability of Owner to Contractor, no present or future partner or affiliate of Owner or any agent, officer, director, or employee of Owner, or of the various departments comprising Owner, or anyone claiming under Owner has or shall have any personal liability to Contractor or to anyone claiming through or under Contractor by reason of the execution or performance of this Agreement.

ARTICLE 8 WARRANTY:

8.1 Contractor hereby warrants that the materials and equipment provided for the Work will be of good quality and new unless otherwise required or permitted by the Owner; that the construction will be free from faults and defects; and that the construction will conform with the requirements of the plans, specifications, drawings and the terms of this Agreement.

8.2 Contractor shall provide warranty services for the Work for a **full twelve (12) months** following Final Completion and final payment. Just before the warranty period expires, Contractor shall attend an on-site meeting with the Owner to ensure that all warranty issues have been identified and properly remedied.

ARTICLE 9 PREVAILING WAGE RATE:

9.1 Duty to Pay Prevailing Wage Rates. The Contractor shall pay not less than the wage scale of the various classes of labor as shown on the “Prevailing Wage Schedule”, as defined below. The specified wage rates are minimum rates only, and are not representations that qualified labor adequate to perform the Work is available locally at the prevailing wage rates. The Owner is not bound to pay—and will not consider—any claims for additional compensation made by any Contractor because the Contractor pays wages in excess of the applicable minimum rate contained in the Agreement. The “Prevailing Wage Schedule” is not a representation that quantities of qualified labor adequate to perform the Work may be found locally at the specified wage rates.

9.1.2 For classifications not shown, workers shall not be paid less than the wage indicated for Laborers. The Contractor shall notify each worker commencing work on the Project of the worker’s job classification and the established minimum wage rate required to be paid, as well as the actual amount being paid. The notice must be delivered to and signed in acknowledgement of receipt by the employee and must list both the monetary wages and fringe benefits to be paid or furnished for each classification in which the worker is assigned duties. When requested by Owner, competent evidence of compliance with the Texas Prevailing Wage Law shall be furnished by Contractor.

9.1.3 A copy of each worker wage rate notification shall be submitted to the Owner with the Application for Payment for the period during which the worker began on-site activities.

9.2 Prevailing Wage Schedule. Pursuant to Texas Government Code Section 2258.022(2), the general prevailing rate of per diem wages for each craft or type of worker needed to execute the Contract and the prevailing rate for legal holiday and overtime work shall be the most recent prevailing wage rate for Williamson County, Texas for building construction as determined by the United States Department of Labor in accordance with the Davis-Bacon Act (40 U.S.C. Section 276a et seq.), and its subsequent amendments, which are published and can be obtained online at <https://sam.gov/search/?index=dbra> (the “Prevailing Wage Schedule”). Should the Contractor at any time become aware that a particular skill or trade not reflected on the Prevailing Wage Schedule will be or is being employed in the Work, whether by the Contractor or by a subcontractor, the Contractor shall promptly inform the Owner and shall specify a wage rate for that skill or trade, which shall bind the Contractor.

9.3 Penalty for Violation. The Contractor and any Subcontractor shall pay to the Owner a penalty of sixty dollars (\$60.00) for each worker employed for each calendar day, or portion thereof, that the worker is paid less than the wage rates stipulated in the Prevailing Wage Schedule or any supplement or update thereto pursuant to provisions above. The Contractor and each Subcontractor shall keep, or cause to be kept, an accurate record showing the names and occupations of all workers employed in connection with the Work, and showing the actual per

diem wages paid to each worker, which records shall be open at all reasonable hours for the inspection by the Owner.

9.4 Complaints of Violations of Prevailing Wage Rates. Within thirty-one (31) days of receipt of information concerning a violation of Texas Government Code, Chapter 2258, the Owner shall make an initial determination as to whether good cause exists to believe a violation occurred. The Owner's decision on the initial determination shall be reduced to writing and sent to the Contractor or Subcontractor against whom the violation was alleged, and to the affected worker. When a good cause finding is made, the Owner shall retain the full amounts claimed by the claimant or claimants as the difference between wages paid and wages due under the Prevailing Wage Schedule and any supplements thereto, together with the applicable penalties, such amounts being subtracted from successive progress payments pending a final decision on the violation.

9.5 Arbitration Required if Violation not Resolved. After the Owner makes its initial determination, the affected Contractor or Subcontractor and worker have fourteen (14) days in which to resolve the issue of whether a violation occurred, including the amount that should be retained by Owner or paid to the affected worker. If the Contractor or Subcontractor and affected worker reach an agreement concerning the worker's claim, the Contractor shall promptly notify the Owner in a written document signed by the worker. If the Contractor or Subcontractor and affected worker do not agree before the fifteenth (15th) day after the Owner's determination, the Contractor or Subcontractor and affected worker must participate in binding arbitration in accordance with the Texas General Arbitration Act, Chapter 171, Tex. Civ. Prac. & Rem. Code. The parties to the arbitration have ten (10) days after the expiration of the fifteen (15) days referred to above, to agree on an arbitrator; if by the eleventh (11th) day there is no agreement to an arbitrator, a district court shall appoint an arbitrator on the petition of any of the parties to the arbitration.

9.6 Arbitration Award. If an arbitrator determines that a violation has occurred, the arbitrator shall assess and award against the Contractor or Subcontractor the amount of penalty as provided herein and the amount owed the worker. The Owner may use any amounts retained hereunder to pay the worker the amount as designated in the arbitration award. If the Owner has not retained enough from the Contractor or Subcontractor to pay the worker in accordance with the arbitration award, the worker has a right of action against the Contractor and Subcontractor as appropriate, and the surety of either to receive the amount owed, attorneys' fees and court costs. The Contractor shall promptly furnish a copy of the arbitration award to the Owner.

9.7 Prevailing Wage Retainage. Money retained pursuant to this section shall be used to pay the claimant or claimants the difference between the amount the worker received in wages for labor on the Project at the rate paid by the Contractor or Subcontractor and the amount the worker would have received at the general prevailing wage rate as provided by the agreement of the claimant and the Contractor or Subcontractor affected, or in the arbitrator's award. The full statutory penalty of sixty dollars (\$60.00) per day of violation per worker shall be retained by the Owner to offset its administrative costs, pursuant to Texas Government Code, §2258.023. Any retained funds in excess of these amounts shall be paid to the Contractor on the earlier of the next progress payment or final payment. Provided, however, that the Owner shall have no duty to

release any funds to either the claimant or the Contractor until it has received the notices of agreement or the arbitration award as provided in this section.

9.8 No Extension of Time. If the Owner determines that good cause exists to believe a violation has occurred, the Contractor shall not be entitled to an extension of time for any delay arising directly or indirectly from of the procedures set forth in this section.

ARTICLE 10 BONDS:

10.1 Performance Bond. Upon execution of this Agreement, Contractor shall provide a Performance Bond in the amount of 100% of the Contract Price. The surety for a Performance Bond shall meet the requirements of Texas law and the requirements set forth in the Agreement.

10.2 Payment Bond. Upon execution of this Agreement, Contractor shall provide a Payment Bond in the amount of 100% of the Contract Price, as security for the true and faithful payment in full of all subcontractors and persons performing labor, services, materials, machinery, and fixtures in connection with the Work. The surety for a Payment Bond shall meet the requirements of Texas law and the requirements set forth in the Agreement.

10.3 Warranty Bond. Upon Final Completion, Contractor shall provide a Warranty Bond in the amount of 20% of the Contract Price, as security for the true and faithful performance of all warranties set forth in the Agreement.

ARTICLE 11 TERMINATION OR SUSPENSION OF THE AGREEMENT

11.1 Termination by Contractor

If one of the reasons described below exists, the Contractor may, upon thirty (30) business days written notice to the Owner, terminate the Agreement and recover from the Owner payment for Work executed, including reasonable overhead, profit, and costs incurred by reason of such termination:

- 11.1.1** Issuance of an order of a court or other public authority having jurisdiction that requires all Work to be stopped;
- 11.1.2** An act of government, such as a declaration of national emergency that requires all Work to be stopped;
- 11.1.3** Because the Owner has not issued a Certificate for Payment and has not notified the Contractor of the reason for withholding certification as provided in the Agreement, or because the Owner has not made payment on an undisputed Certificate for Payment within the time stated in the Agreement; or
- 11.1.4** If the Work is stopped for a period of ninety (90) consecutive days through no act or fault of the Contractor or a Subcontractor, Sub-subcontractor or their agents or employees or any other persons or entities performing portions of the Work under direct or indirect contract with the Agreement.

11.2 Termination by the Owner for Cause

11.2.1 The Owner may terminate the Agreement if the Contractor:

- 11.2.1.1 Fails to commence the Work in accordance with the provisions of the Agreement;
- 11.2.1.2 Fails to prosecute the Work to completion thereof in a diligent, efficient, timely, workmanlike, skillful and careful manner and in strict accordance with the provisions of the Agreement;
- 11.2.1.3 Fails to use an adequate amount or quality of personnel or equipment to complete the Work without undue delay;
- 11.2.1.4 Fails to perform any of its obligations under the Agreement;
- 11.2.1.5 Fails to make prompt payments when due to its Subcontractors and Suppliers, or as required by **Texas Government Code, Chapter 2251**;
- 11.2.1.6 Files any petition or other pleading seeking any relief under any provisions of the Federal Bankruptcy Act, as amended, or any other federal or state statute or law providing for reorganization of debts or other relief from creditors, permits a receiver or other person to be appointed on account of its insolvency or financial condition, or becomes insolvent;
- 11.2.1.7 Creates any situation or state of facts which would authorize or permit an involuntary petition in bankruptcy to be filed against Contractor; or
- 11.2.1.8 Has not met or in Owner's opinion will not meet the dates of Substantial Completion set forth in the Agreement.

11.2.2 When any of the reasons under **Paragraph 11.2.1** exist, the Owner, in its sole and absolute discretion, may without prejudice to any other rights or remedies of the Owner and after giving the Contractor and the Contractor's surety, if any, **thirty (30) calendar days** written notice, terminate employment of the Contractor and may, subject to any prior rights of the surety, exclude the Contractor from the Project site and take possession of all materials, equipment, tools, and construction equipment and machinery thereon owned by the Contractor; accept assignment of subcontracts of Contractors subcontractors; and finish the Work by whatever reasonable method the Owner may deem expedient. Upon written request of the Contractor, the Owner shall furnish to the Contractor a detailed accounting of the costs incurred by the Owner in finishing the Work.

11.2.3 When the Owner terminates the Agreement for one of the reasons stated in **Paragraph 11.2.1**, the Contractor shall not be entitled to receive further payment until the Work is finished. In the event that it is determined that sufficient cause did not exist for termination under this **Section 11.2**, then the termination shall be considered a termination for convenience, under **Section 11.4**, below.

11.2.4 If the unpaid balance of the Contract Price exceeds costs of finishing the Work, including compensation for expenses made necessary thereby, and other damages and costs incurred by the Owner in finishing the Work and not expressly waived, such excess shall be paid to the Contractor. If such costs and damages exceed the unpaid balance, the Contractor shall pay the difference to the Owner.

11.3 Suspension by the Owner for Convenience

11.3.1 The Owner may, without cause, order the Contractor in writing to suspend, delay or interrupt the Work in whole or in part for such period of time as the Owner may determine.

11.3.2 The Contract Price and Contract Time shall be adjusted for increases in the cost and time caused by suspension, delay or interruption as described in **Paragraph 11.3.1**. Adjustment of the Contract Price shall include profit. No adjustment shall be made to the extent:

11.3.2.1 that performance is, was or would have been so suspended, delayed or interrupted by another cause for which the Contractor is responsible; or

11.3.2.2 that an equitable adjustment is made or denied under another provision of the Agreement.

11.4 Termination by the Owner for Convenience

11.4.1 The Owner may, at any time, terminate the Agreement for the Owner's convenience and without cause.

11.4.2 Upon receipt of written notice from the Owner of such termination for the Owner's convenience, the Contractor shall

11.4.2.1 Cease operations as directed by the Owner in the notice;

11.4.2.2 Take actions necessary, or that the Owner may direct, for the protection and preservation of the Work; and

11.4.2.3 Except for Work directed to be performed prior to the effective date of termination stated in the notice, terminate all existing subcontracts and purchase orders and enter into no further subcontracts and purchase orders.

11.4.3 Upon Owner's termination for convenience, costs of the Work executed, including reasonable overhead and profit, incurred to and including the date of termination, will be due and payable to Contractor in accordance with the Agreement.

ARTICLE 12 MISCELLANEOUS PROVISIONS:

12.1 Interest and Late Payments. Owner's payment for goods and services shall be governed by Chapter 2251 of the Texas Government Code. Interest charges for any overdue payments shall be paid by Owner in accordance with Texas Government Code Section 2251.025. More specifically, the rate of interest that shall accrue on a late payment is the rate in effect on September 1 of Owner's fiscal year in which the payment becomes due. The said rate in effect on September 1 shall be equal to the sum of one percent (1%); and (2) the prime rate published in the Wall Street Journal on the first day of July of the preceding fiscal year that does not fall on a Saturday or Sunday.

In the event that an error appears in an invoice/application for payment submitted by Contractor, Owner shall notify Contractor of the error not later than the twenty first (21st) day after the date Owner receives the invoice/application for payment. If the error is resolved in favor of Contractor, Contractor shall be entitled to receive interest on the unpaid balance of the invoice/application for payment submitted by Contractor beginning on the date that the payment for the invoice/application for payment became overdue. If the error is resolved in favor of the Owner, Contractor shall submit a corrected invoice/application for payment that must be paid in accordance within the time set forth above. The unpaid balance accrues interest as provided by Chapter 2251 of the Texas Government Code if the corrected invoice/application for payment is not paid by the appropriate date.

12.2 Audits. Contractor agrees that Owner or its duly authorized representatives shall, until the expiration of three (3) years after final payment under this Agreement, have access to and the right to examine and photocopy any and all books, documents, papers and records of Contractor which are directly pertinent to the services to be performed under this Agreement for the purposes of making audits, examinations, excerpts, and transcriptions. Contractor agrees that Owner shall have access during normal working hours to all necessary Contractor facilities and shall be provided adequate and appropriate work space in order to conduct audits in compliance with the provisions of this section. Owner shall give Contractor reasonable advance notice of intended audits.

12.3 Assignment. This Agreement is a personal service contract for the services of Contractor, and Contractor's interest in this Agreement, duties hereunder and/or fees due hereunder may not be assigned or delegated to a third party.

12.4 Governing Law and Venue. This Agreement and all of the rights and obligations of the parties and all of the terms and conditions shall be construed, interpreted and applied in accordance with and governed by and enforced under the laws of the State of Texas without reference to its conflicts of law provisions. Williamson County, Texas where the Project is located shall be the sole place of venue for any legal action arising from or related to this Agreement or the Project in which the Owner is a party.

12.5 Binding Effect. This Agreement shall be binding upon and inure to the benefit of the parties and their respective permitted assigns and successors.

12.6 Notices. All notices, consents, approvals, demands, requests or other communications relied on by the parties shall be in writing. Written notice shall be deemed to have been given when delivered in person to the designated representative of the Contractor or Owner for whom it is intended; or sent by U. S. Mail to the last known business address of the designated representative.

12.7 Severability. Should any term or provision of this Agreement be held invalid or unenforceable in any respect, the remaining terms and provisions shall not be affected and this Agreement shall be construed as if the invalid or unenforceable term or provision had never been included.

12.8 Relationship of the Parties. Contractor shall be an independent contractor under this agreement and shall assume all of the rights, obligations, liabilities, applicable to it as such independent contractor hereunder and any provisions in this agreement which may appear to give Owner the right to direct Contractor as to details of doing the Work herein covered or to exercise a measure of control over the Work shall be deemed to mean that Contractor shall follow the desires of Owner in the results of the Work only. Owner shall not retain or have the right to control the Contractor's means, methods or details pertaining to the Contractor's performance of the Work described herein, nor shall Owner have the power to direct the order in which Contractor's Work is performed under this agreement. Owner and Contractor hereby agree and declare that Contractor is an Independent Contractor and as such meets the qualifications of an Independent Contractor under Texas Worker's Compensation Act, Texas Labor Code, Section 406.141, that the Contractor is not an employee of Owner for purposes of this Agreement, and that the Contractor and its employees, agents and sub-subcontractors shall not be entitled to worker's compensation coverage or any other type of insurance coverage held by Owner.

12.9 Force Majeure. If the party obligated to perform is prevented from performance by an act of war, order of legal authority, act of God, or other unavoidable cause not attributable to the fault or negligence of said party, the other party shall grant such party relief from the performance of this Agreement. The burden of proof for the need of such relief shall rest upon the party obligated to perform. To obtain release based on force majeure, the party obligated to perform shall file a written request with the other party.

12.10 No Waiver of Sovereign Immunity. Nothing herein shall be construed as a waiver of sovereign immunity by Owner.

12.11 Current Revenues. Under Texas law, a contract with a governmental entity that contains a claim against future revenues is void; therefore, each party paying for the performance of governmental functions or services must make those payments from current revenues available to the paying party.

12.12 Compliance with Laws. Contractor shall comply with all federal, state, and local laws, statutes, ordinances, rules and regulations, and the orders and decrees of any courts or administrative bodies or tribunals in any matter affecting the performance of this Agreement, including, without limitation, Worker's Compensation laws, minimum and maximum salary and wage statutes and regulations, licensing laws and regulations. When required, Contractor shall furnish the Owner with certification of compliance with said laws, statutes, ordinances, rules, regulations, orders, and decrees above specified.

12.13 Entire Agreement & Incorporated Documents; Conflicting Terms. This Agreement constitutes the entire agreement between the parties and may not be modified or amended other than by a written instrument executed by both parties.

The following documents shall comprise the Contract Documents:

1. This Agreement between Owner and Contractor;
2. Exhibit "A" – Plans and Specifications;
3. Addenda issued prior to the Effective Date of this Agreement;

- 4. Cooperative Contract Buy Board 728-24; and
- 5. All Change Orders and any other Modifications issued after the Effective Date of this Agreement.

In the event of a dispute or conflict relating to the terms and conditions of the Contract Documents, applicable documents will be referred to for the purpose of clarification, conflict resolution or for additional detail in the following order of precedence:

- 1. This Agreement between Owner and Contractor;
- 2. Exhibit “A” – Plans and Specifications;
- 3. Addenda issued prior to the Effective Date of this Agreement;
- 4. Cooperative Contract Buy Board 728-24; and
- 5. All Change Orders and any other Modifications issued after the Effective Date of this Agreement.

BY SIGNING BELOW, the Parties have executed and bound themselves to this Agreement to be effective as of the date of the last party’s execution hereof.

OWNER:

WILLIAMSON COUNTY, TEXAS,
a political subdivision of the state of Texas

By: _____

Printed Name: _____

Title: _____

Date: _____

CONTRACTOR:

Falkenberg Construction Co., Inc.

By:  _____

Printed Name: John E. Castro

Title: President

Date: 21 Nov 2025

Exhibit “A”

Plans and Specifications

Location of Work: Brushy Creek Regional Trail, Cedar Park, TX 78613

Scope of Work:

This project consists of drainage and concrete trail improvements along the Brushy Creek Regional Trail. Work includes grading, concrete placement, erosion control, and site restoration per architectural plans.

The Contractor will perform the following work:

Site Preparation & Demolition

- Strip and remove topsoil, clear vegetation, protect existing structures, and stockpile excavated DG on site.

Earthwork and Grading

- Perform excavation and fill operations, compact fill in 6-inch lifts, and maintain flow line slopes per plan.

Concrete Trail and Valley Gutters

- Install reinforced concrete trail (Class 'A') and 18-inch valley gutters with broom finish and curing compound

Drainage and Riprap Installation

- Install concrete and rock riprap (8–12 inch rock) with toe ditch and slope protection per details.

Erosion, Sedimentation, and Tree Protection

- Install silt fence, rock berms, filter dikes, and tree protection fencing per erosion control notes. Provide all required samples and QC testing
- Daily Clean
- Final Clean

Exclusions:

- Sales tax, overtime, permit fees
- MEP Work
- Permanent landscaping or irrigation systems
- Asphalt paving, striping, or signage not shown on drawings
- Traffic control beyond active construction zone
- Unforeseen utility conflicts or relocations not shown
- Temporary power or water service connections

Williamson County, Texas BRUSHY CREEK REGIONAL TRAIL-DRAINAGE CORRECTION

WILLIAMSON COUNTY, TEXAS
BRUSHY CREEK REGIONAL TRAIL-DRAINAGE
CORRECTION



BID SET

Approved by the Williamson County, Texas
this _____ day of _____, 2025.



KASBERG, PATRICK & ASSOCIATES, LP
CONSULTING ENGINEERS
GEORGETOWN, TEXAS 78626
FIRM REGISTRATION NO. F-510

A handwritten signature in blue ink, appearing to read "Alvin R. Sutton, III".

10/20/2025

FILE: P:\Williamson County\2024\24-179 BRUSHY CREEK REGIONAL TRAIL-DRAINAGE CORRECTION\CAD\Plans\GENERAL SHEETS.dwg LAST SAVED: 10/20/2025 11:40:32 AM LAYOUT: SHEET INDEX AND LOCATION MAP

INDEX OF SHEETS

GENERAL SHEETS

- G-01 COVER
- G-02 SHEET INDEX AND LOCATION MAP
- G-03 TCEQ AND GENERAL CONSTRUCTION NOTES
- G-04 EROSION-SEDIMENTATION & TREE PROTECTION NOTES AND DETAILS

PLAN SHEETS

- P-01 STA 1+00.00 TO STA 6+00.00
- P-02 STA 6+00.00 TO STA 11+00.00
- P-03 STA 11+00.00 TO STA 16+00.00
- P-04 STA 16+00.00 TO STA 21+00.00
- P-05 STA 21+00.00 TO STA 26+30.00
- P-06 STA 26+30.00 TO END

DETAIL SHEETS

- D-01 DETAIL-01
- D-02 DETAIL-02
- D-03 DETAIL-03

GENERAL

- MON MONUMENT
- FLAG POLE
- IPS IRON PIN SET
- IPF IRON PIN FOUND
- SIGN
- BM BENCHMARK
- TREE SYMBOL
- NS NAIL SET/FOUND
- FND "X" IN CONCRETE FOUND/SET (LABEL)
- BH BORE HOLE
- BP BOLLARD POST
- FP FENCE POST
- GL GROUND LIGHT
- GR GROUNDING ROD
- RRCBX RAILROAD CONTROL BOX
- MS MARKER SIGN
- MBX MAIL BOX

ELECTRIC

- EB ELECTRIC BOX
- LP LIGHT POLE
- PP POWER POLE
- GUY GUY
- MANHOLE
- JBX JUNCTION BOX
- TSP TRAFFIC SIGNAL POLE/BOX/CONTROL PANEL

TELLECOMM/CABLE

- TRB TELEPHONE RISER BOX
- MANHOLE
- CBX CABLE BOX
- CPED CABLE PEDESTAL
- JBX JUNCTION BOX
- TP TELEPHONE POLE
- PBX PULL BOX

WATER

- FH FIRE HYDRANT
- WV WATER VALVE 1
- WV WATER VALVE 2
- WM WATER METER
- MANHOLE
- PIPE FITTING
- REDUCER
- HB HOSE BIB
- SCBX SPRINKLER CONTROL BOX
- SCV SPRINKLER CONTROL VALVE

WASTEWATER

- MANHOLE
- PIPE FITTING
- CLEANOUT

STORM SEWER

- MANHOLE
- AREA DRAIN

GAS

- GAS METER



LOCATION MAP

BID SET

NO.	DATE	REVISION	BY
© 2025 Kasberg, Patrick & Associates, LP KPA Firm Registration Number F-510		Plot Date: 10/20/2025 11:42:37 AM Plotted By: AJACOB	

PROJECT NO. 24-179
 DRAWN BY Aneena Jacob
 DESIGNED BY Alvin R. Sutton III, P.E.
 APPROVED BY *[Signature]*
 DATE 10/20/2025

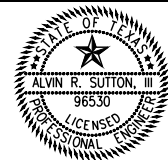

KASBERG, PATRICK & ASSOCIATES, LP
 CONSULTING ENGINEERS
 GEORGETOWN, TEXAS 78626

WILLAMSON COUNTY, TEXAS

BRUSHY CREEK REGIONAL TRAIL-DRAINAGE CORRECTION

SHEET INDEX AND LOCATION MAP

SHEET NO.
G-02 OF
04 SHEETS

FILE: P:\Williamson County\2024\24-179 BRUSHY CREEK REGIONAL TRAIL-DRAINAGE CORRECTION\CAD\Plans\GENERAL\2024-181 GENERAL SHEETS.dwg LAST SAVED: 10/20/2025 11:40:32 AM LAYOUT: TCEQ AND GENERAL CONSTRUCTION NOTES

**Texas Commission on Environmental Quality
Water Pollution Abatement Plan General Construction Notes**

- A written notice of construction must be submitted to the TCEQ regional office at least 48 hours prior to the start of any regulated activities. This notice must include:
 - the name of the approved project;
 - the activity start date; and
 - the contact information of the prime contractor.
- All contractors conducting regulated activities associated with this project must be provided with complete copies of the approved Water Pollution Abatement Plan (WPAP) and the TCEQ letter indicating the specific conditions of its approval. During the course of these regulated activities, the contractors are required to keep on-site copies of the approved plan and approval letter.
- If any sensitive feature(s) (caves, solution cavity, sink hole, etc.) is discovered during construction, all regulated activities near the sensitive feature must be suspended immediately. The appropriate TCEQ regional office must be immediately notified of any sensitive features encountered during construction. Construction activities may not be resumed until the TCEQ has reviewed and approved the appropriate protective measures in order to protect any sensitive feature and the Edwards Aquifer from potentially adverse impacts to water quality.
- No temporary or permanent hazardous substance storage tank shall be installed within 150 feet of a water supply source, distribution system, well, or sensitive feature.
- Prior to beginning any construction activity, all temporary erosion and sedimentation (E&S) control measures must be properly installed and maintained in accordance with the approved plans and manufacturers specifications. If inspections indicate a control has been used inappropriately, or incorrectly, the applicant must replace or modify the control for site situations. These controls must remain in place until the disturbed areas have been permanently stabilized.
- Any sediment that escapes the construction site must be collected and properly disposed of before the next rain event to ensure it is not washed into surface streams, sensitive features, etc.
- Sediment must be removed from the sediment traps or sedimentation basins not later than when it occupies 50% of the basin's design capacity.
- Litter, construction debris, and construction chemicals exposed to stormwater shall be prevented from being discharged offsite.
- All spoils (excavated material) generated from the project site must be stored on-site with proper E&S controls. For storage or disposal of spoils at another site on the Edwards Aquifer Recharge Zone, the owner of the site must receive approval of a water pollution abatement plan for the placement of fill material or mass grading prior to the placement of spoils at the other site.
- If portions of the site will have a temporary or permanent cease in construction activity lasting longer than 14 days, soil stabilization in those areas shall be initiated as soon as possible prior to the 14th day of inactivity. If activity will resume prior to the 21st day, stabilization measures are not required. If drought conditions or inclement weather prevent action by the 14th day, stabilization measures shall be initiated as soon as possible.
- The following records shall be maintained and made available to the TCEQ upon request:
 - the dates when major grading activities occur;
 - the dates when construction activities temporarily or permanently cease on a portion of the site; and
 - the dates when stabilization measures are initiated.
- The holder of any approved Edward Aquifer protection plan must notify the appropriate regional office in writing and obtain approval from the executive director prior to initiating any of the following:
 - any physical or operational modification of any water pollution abatement structure(s), including but not limited to ponds, dams, berms, sewage treatment plants, and diversionary structures;
 - any change in the nature or character of the regulated activity from that which was originally approved or a change which would significantly impact the ability of the plan to prevent pollution of the Edwards Aquifer;
 - any development of land previously identified as undeveloped in the original water pollution abatement plan.

Austin Regional Office
12100 Park 35 Circle, Building A
Austin, Texas 78753-1808
Phone (512) 339-2929
Fax (512) 339-3795

San Antonio Regional Office
14250 Judson Road
San Antonio, Texas 78233-4480
Phone (210) 490-3096
Fax (210) 545-4329

THESE GENERAL CONSTRUCTION NOTES MUST BE INCLUDED ON THE CONSTRUCTION PLANS PROVIDED TO THE CONTRACTOR AND ALL SUBCONTRACTORS.

TCEQ-0592 (Rev. July 15, 2015)

General Notes

- All barricades, signs, and traffic control for this project shall conform to the latest edition of the Texas Manual on Uniform Traffic Control Devices for Streets and Highways.
- The bidders for this project shall familiarize themselves with all requirements of working in state and Williamson County rights-of-way and easements. The bidders shall familiarize themselves with all insurance requirements for said work and shall include in their bids, insurance costs and insurance premiums that provide for the state of Texas, the Williamson County and the engineer as additional insured's under the contractor's policies.
- Blasting is not permitted on this project.
- All construction operations shall be accomplished in accordance with applicable regulations of the U.S. Occupational Safety And Health Administration. Copies of the OSHA standards may be purchased from the U.S. government printing office: information and related reference materials may be obtained from OSHA; 903 San Jacinto, Austin, Texas.
- These plans prepared by Kasberg, Patrick & Associates, LP, do not extend to or include designs or systems pertaining to the safety of the contractor or its employees, agents or representatives in the performance of the work. The seal of Kasberg, Patrick & Associates, LP registered professional engineer(s) hereon does not extend to any such safety systems that may now or hereafter be incorporated in the work. The contractor shall prepare or obtain the appropriate safety systems, including the plans and specifications.
- Contractor shall comply with all applicable local, state and federal requirements regarding excess and waste material, including methods of handling and disposal.
- Contractor shall maintain access to public and private facilities during construction. Construction activities shall be coordinated with the Williamson County community owned utilities.
- Contractor shall notify the Williamson County community owned utilities a minimum of 3 working days, (Monday-Friday) in advance of construction startup, followed by a letter of confirmation. Contractor shall also give a minimum of 3 working days, (Monday-Friday), notice to all authorized inspectors, superintendents or persons in charge of private and public utilities affected by his operations prior to commencement of work.
- Location of existing utilities shown on the plans was compiled from record information. No warranty is implied as to the actual location of existing utilities. Contractor shall field verify locations of existing utilities prior to the commencement of construction. Contractor shall call the Williamson County at (512) 930-3555. If there are any conflicts between proposed and existing utilities, or if the existing utilities are in any way different from what is shown on the drawings, then it shall be the contractor's responsibility to notify the city or other affected utility before proceeding with any construction. The contractor shall be responsible for resolving all conflicts at his expense. The Williamson County will consider any conflicts at said locations on a case-by-case basis in order to determine if the contractor should be reimbursed for his expense in solving said conflict.
- Contractor shall make all due precautions to protect existing facilities from damage. Any damage to existing facilities incurred as a result of these construction operations are to be repaired immediately by the contractor to at least the preexisting condition at no additional cost to the Williamson County.
- Contractor shall coordinate interruptions of all utilities and services with all applicable utility company or companies. All work shall be in accordance with the requirements of the applicable utility company or agency involved.
- When un-located or incorrectly located underground piping or a break in a line or other utilities and services are encountered during site work operations, the contractor shall notify the applicable utility company immediately to obtain procedure directions. Contractor shall cooperate with the applicable utility company in maintaining active services in operation.
- Contractor shall locate material storage areas away from storm water conveyance systems. Contractor shall provide protected storage areas for chemicals, paints, solvents, fertilizers and other potentially toxic materials off site.
- No open burning is allowed within the Williamson County limits. Burning is allowed in Williamson county by air curtain destructors method and prior written approval from applicable government agencies at the contractor's expense. The contractor can haul cleared vegetation to an acceptable off-site location with written approval by the owner's representative. Prior to construction the contractor shall designate to the Williamson County's representative, which method will be used for disposal of cleared vegetation.
- Fuel storage is not allowed on this project.
- Contractor shall advise owner immediately, verbally and in writing, of any fuel or toxic material spills onto the project construction area and the actions to be taken to remedy the problem.
- Contractor is responsible for disposing of his fuels, materials, and contaminated excavations in a legally approved manner.
- Contractor is responsible for complying with all applicable environmental laws.
- Contractor is responsible for providing and maintaining sanitary facilities on this project for employees.

- Contractor shall coordinate all materials testing, including soil density tests and related soils analysis. Tests shall be accomplished by an independent laboratory under contract with the Williamson County, at the frequency, time and location as specified in the technical specifications. A copy of the test results shall be forwarded to the Williamson County's representative, the Williamson County utilities, and the contractor. Tests, which show unsatisfactory results, shall be repeated at the expense of the contractor subsequent to the contractor's remedial activities.
- The trench excavation and shoring safety plan system as required by the laws of the state of Texas and as outlined in the technical specifications will be required as a minimum trench safety measure and shall be submitted to the Williamson County for acceptance prior to the beginning of construction. Implementation of the submitted trench safety plan shall be the sole responsibility of the contractor.
- Existing paving, buildings and other items shown on the plans is not specifically related to the work of the contractor and is shown for information only.
- Any water hauled to the site during the installation shall be paid by the contractor.
- TxDOT requires 48-hour notification prior to any proposed work in state right of way.
- This project is a calendar day project and therefore shall be void of rain days as credit to construction time. The Williamson County will not accept rain days unless a month within the project time has had rain days in excess of the average rain days for that month. Days of drying for the project site will not be considered.

Month	Rain Days
January	7 days
February	7 days
March	7 days
April	7 days
May	8 days
June	6 days
July	6 days
August	5 days
September	7 days
October	7 days
November	7 days
December	7 days

Construction Layout/Project Coordination

- The Williamson County will provide the daily on-site construction representation for this project.
- Pre-construction conference
 - Prior to beginning work on the project and soon after the award of the contract, a conference will be held among the representatives of the Williamson County, the engineer, the contractor, and any subcontractor that will be involved in the work. At that time, the contractor shall submit charts or briefs, outlining the manner of execution of the work that is intended in order to complete the specified work within the allotted time. This conference will more completely establish the sequence of work to be followed and establish the estimated progress schedule for completion of the various tasks. When applicable, the pre-construction conference will be held only after installation of the erosion and sedimentation controls. This conference may take place on the site to demonstrate competence with the erosion and sedimentation control plan and water pollution abatement plan.
 - In addition, at this conference, the contractor shall be responsible for furnishing the engineer with all of the following, as specified herein or as directed by the engineer:
 - Samples of all materials to be used on the project with identification as to product name; name, location, phone number (including area code) and mailing address of product source and manufacturer, if different from source; content of product; amount of each ingredient in the product, and manufacturer's directions as to use and application of the product, if applicable.
 - Manufacturer's literature of all materials and equipment installed on the project.
- Protection of vehicular and pedestrian traffic is of the utmost importance for the project. The traffic control and sequence of construction plan shall address all anticipated situations in this regard with sufficient detail. The contractors plan will be reviewed by local TxDOT officials and the Williamson County.
- The plans for this project show proposed elevations, slopes and dimensions that are intended for actual placement. However, there may be some instances where existing conditions make it impractical to achieve the ideal. In those instances, the Williamson County will assist the contractor in making proper field changes to better account for field conditions.
- The engineer for the project shall mark the limits of construction prior to commencement of the project.

Site Grading Notes

- Contractor shall control dust caused by the work and comply with pollution control regulations of governing authorities.
- Contractor shall remove built up material on adjacent public roadways resulting from his work. Cleaning shall be at least once a day.

- Contractor shall protect stockpiled material such that storm water will not adversely affect erosion control, sidewalks, traffic, private property, or the San Gabriel River.
- Required fill embankment shall be placed and compacted per technical specifications in maximum 6-inch loose lifts and compacted as stated in the specifications.

Paving And Concrete Notes

- Any existing pavement, curbs and/or sidewalk damaged or removed by the contractor that are not a part of this contract shall be repaired by the contractor to at least the preexisting condition at his expense before acceptance of the work.
- The contractor shall provide the Williamson County community owned utilities engineer with a barricade and signing plan, which will include how traffic will be handled during construction. The barricades, signs and lights shall conform to the latest edition of the Texas Manual On Uniform Traffic Control Devices For Streets And Highways.
- All concrete to be class "a" for site work per technical specifications and all reinforcing steel to be ASTM A-615 grade 60, unless otherwise noted.
- Natural subgrade - loose, disturbed or undisturbed natural subgrade beneath pavement should be scarified and rolled. Subgrade compactions shall not exceed 100%. Proof-rolling and preparation of subgrade shall be in accordance with TxDOT item 216 "proof rolling" and item 132 embankment.
- Concrete rip rap shall be 4-inch thickness, class "b" concrete with 6" x 6" x #6 welded wire flat-sheet mesh. Finished concrete shall receive a broom finish and sprayed with type 2 membrane curing compound. The rip rap shall be placed with a 24-inch depth by 6-inch wide toe ditch at the bottom of slope edge and with an 18-inch depth by 6-inch wide toe ditch at the top of slope edge.

Project Notes

- The contractor to contact the Williamson County at (512) 930-3555 for existing utility locations prior to any excavation. In advance of construction, the contractor shall verify the locations of all utilities to be extended, tied to or altered, or subject to damage/inconvenience by the construction operations. The Williamson County water and wastewater maintenance responsibility ends at right-of-way row/easement lines.
- Contractor shall strip 6 inches of topsoil from all areas subject to grade modifications. Contractor shall remove any area of weak soil.
- Within Williamson County right-of-way, residential driveways shall have a 10% maximum grade. Non residential driveways are to have a 3% maximum grade for the first thirty (30) feet off the edge of pavement.
- The contractor shall be responsible and liable for all job site safety, management of job site personnel, supervision of the use of job site equipment and direction of all construction procedures, methods and elements required to complete the construction of the proposed improvements.
- The contractor shall protect all existing fences. In the event that a fence shall be removed, the contractor shall replace said fence or portion thereof with the same type of fencing to a quality of equal or better than the original fence.

Testing And Submittals

- The contractor shall be responsible for providing material samples as well as any manufacturers literature of materials used on this project as required by the engineer. Any costs associated with any sampling and testing shall be the responsibility of the contractor. These costs shall be considered as incidental and the contractor will not be entitled to any additional compensation.
- The contractor shall be responsible for and pay for all charges of testing laboratories for services in connection with initial tests made on all imported materials to the project sites including but not limited to embedment materials, fill material, backfill material, select material, crushed limestone base, subbase, concrete, steel, wood forms, liquid asphalt, aggregate, water, cement, curing compound, guard rail, etc. The tests for which the contractor will typically be responsible are Atterberg limits, sieve analysis, plasticity indices, mix design, California bearing ratios, proctors (moisture density curves) and all tests required by the specifications that prove the material brought to the project sites meets or exceeds the specifications and contract documents. The owner, the Williamson County, will pay all the charges of testing laboratories for services in connection with in place field densities, concrete cylinders testing, HMAC density tests and any in place test required for quality assurance. Retesting after failure of in place tests shall be at the expense of the contractor.

Americans with disabilities act

- This project is intended to conform to the Americans With Disabilities Act.
- The contractor shall be aware of construction procedures, finished product requirements of this act, and coordinate all activities to satisfy this act.

BID SET

NO.	DATE	REVISION	BY
© 2025 Kasberg, Patrick & Associates, LP			
KPA Firm Registration Number F-510			

PROJECT NO. 24-179
DRAWN BY Aneena Jacob
DESIGNED BY Alvin R. Sutton III, P.E.
APPROVED BY *[Signature]*
DATE 10/20/2025



KASBERG, PATRICK & ASSOCIATES, LP
CONSULTING ENGINEERS
GEORGETOWN, TEXAS 78626

WILLAMSON COUNTY, TEXAS
BRUSHY CREEK REGIONAL TRAIL-DRAINAGE CORRECTION
TCEQ AND GENERAL CONSTRUCTION NOTES

SHEET NO.
G-03 OF
04 SHEETS

AJACOB

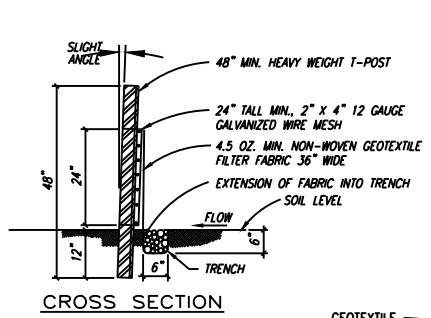

Inspection and maintenance guidelines:

- Inspect all fencing weekly, and after any rainfall event.
- Remove sediment when buildup reaches 6 inches.
- Replace any torn fabric.
- Replace or repair any sections crushed or collapsed in the course of construction activity.

Installation:

- Layout the silt fence following as closely as possible to the contour.
- Clear the ground of debris, rocks, plants (including grasses taller than 2") to provide a smooth flow approach surface. Excavate 4" deep x 4" wide trench on upstream side of face per plans.
- Drive the heavy duty t-post at least 12 inches into the ground and at a slight angle towards the flow.
- Attach the 2" x 4" 12 gauge welded wire mesh to the t-post with 11 1/2 gauge galvanized t-post clips. The top of the wire to be 24" above ground level. The welded wire mesh to be overlapped 6" and tied at least 6 times with hog rings.
- The silt fence to be installed with a skirt a minimum of 11" wide placed on the uphill side of the fence inside excavated trench. The fabric to overlap the top of the wire by 1".
- Anchor the silt fence by backfilling with excavated dirt and rocks.
- Geotextile splices should be a minimum of 18" wide attached in at least 6 places. Splices in concentrated flow areas will not be accepted.

SILT FENCE DETAIL
NOT TO SCALE

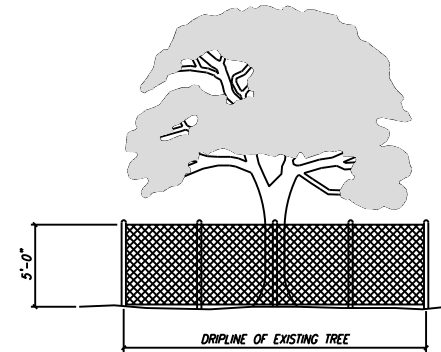

TREE PROTECTION - CHAIN LINK FENCE
NOT TO SCALE

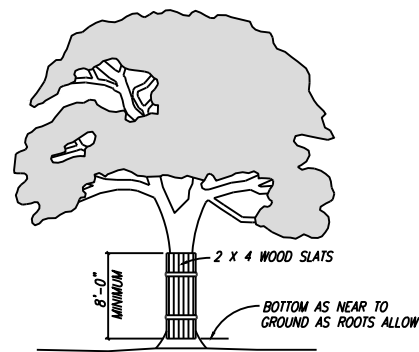

TREE PROTECTION - WOOD SLATS
NOT TO SCALE

Notes:

- Where any exceptions result in a fence being closer than four feet (4'-0") to a tree trunk protect the trunk with strapped-on-planking to a height of eight feet (8'-0"), or to the limits of lower branching in addition to the reduced fencing provided.
- Any roots exposed by construction activity shall be pruned flush with the soil. Backfill root areas with good quality top soil as soon as possible. If exposed root areas are not backfilled within two (2) days, cover them with organic material in a manner which reduces soil temperature, and minimizes water loss due to evaporation.
- Prior excavation or grade cutting within tree dripline. Make a clean cut between the disturbed and undisturbed root zones with a rock saw or similar equipment, to minimize damage to remaining roots.
- Trees most heavily impacted by construction activities should be watered deeply once a week during periods of hot, dry weather. Tree crowns should be sprayed with water periodically to reduce dust accumulation on the leaves.
- Any trenching required for the installation of landscape irrigation shall be placed as far from existing tree trunks as possible.
- No landscape topsoil dressing greater than four inches (4") shall be permitted within the dripline of a tree. No soil is permitted on the root flare of any tree.
- Pruning to provide clearance for structures, vehicular traffic and equipment shall take place before construction begins.

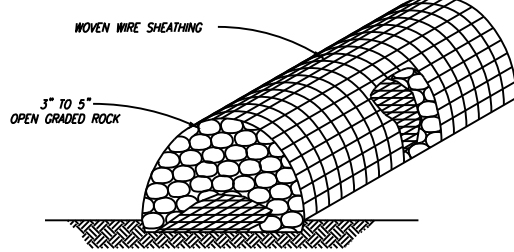
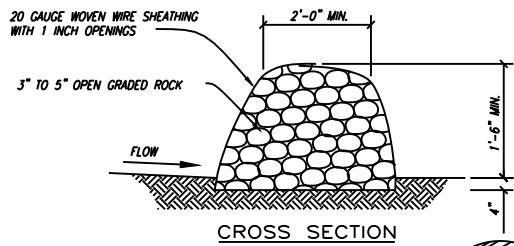

Installation:

- Layout the rock berm following as closely as possible to the contour.
- Clear the ground of debris, rocks or plants that will interfere with installation.
- Place woven wire fabric on the ground along the proposed installation with enough overlap to completely encircle the finished size of the berm.
- Place the rock along the center of the wire to the designated height.
- Wrap the structure with the previously placed wire mesh secure enough so that when walked across the structure retains its shape.
- Secure with tie wire.
- The ends of the berm should be tied into existing upslope grade and the berm should be buried in a trench approx. 4 inches deep to prevent failure of the control.
- The rock berm should be left in place until all upstream areas are stabilized and accumulated silt removed.

Inspection and Maintenance Guidelines:

- Inspection should be made weekly and after each rainfall event by the responsible party. For installations in streambeds, additional daily inspections should be made.
- Remove sediment and other debris when buildup reaches 6 inches and dispose of the accumulated silt in an approved manner.
- Repair any loose wire sheathing.
- The berm should be reshaped as needed during inspection.
- The berm should be replaced when the structure ceases to function as intended due to silt accumulation among the rocks, washout, construction traffic damage, etc.

ROCK BERM DETAIL
NOT TO SCALE

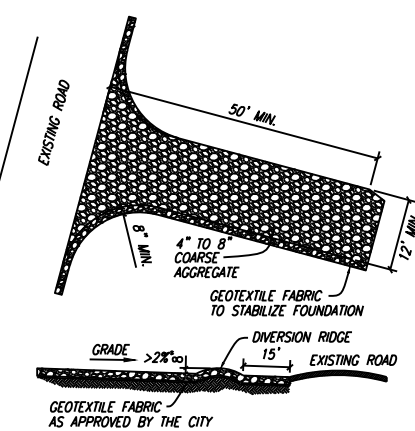

Installation:

- Clear the area of debris, rocks or plants that will interfere with installation.
- Grade the area for the entrance to flow back on to the construction site. Runoff from the stabilized construction entrance onto a public street will not be accepted.
- Place geotextile fabric if required.
- Place rock as required.

Inspections and maintenance guidelines:

- The entrance should be maintained in a condition, which will prevent tracking or flowing of sediment onto public rights-of-way. This may require periodic top dressing with additional stone as conditions demand and repair and/or cleanout of any measures used to trap sediment.
- All sediment spilled, dropped, washed or tracked on to public rights-of-way should be removed immediately by contractor.
- When necessary, wheels should be cleaned to remove sediment prior to entrance onto public rights-of-way.
- When washing is required, it should be done on an area stabilized with crushed stone that drains into an approved sediment trap or sediment basin.
- All sediment should be prevented from entering any storm drain, ditch or water course by using approved methods.

STABILIZED CONSTRUCTION ENTRANCE
NOT TO SCALE

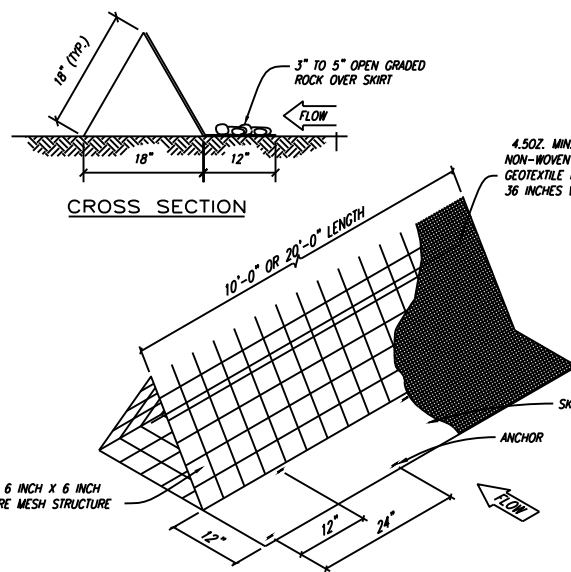

Installation:

- Layout the filter dike following as closely as possible to the contour.
- Clear the ground of debris, rocks or plants that will interfere with installation.
- Place the filter dike sections one at a time, with the skirt on the uphill side towards the direction of flow anchoring each section to the ground before the next section is placed.
- Anchors should be placed on 2'-0" centers alternating from front to back so that there is actually only 1'-0" in between anchors.
- Securely fasten the skirt from one section of filter dike to the next.
- Filter dikes shall maintain continuous contact with the ground.
- After the site is completely stabilized, the dikes and any remaining silt should be removed. Silt should be disposed of in a manner that will not contribute to additional siltation.

Inspection and Maintenance Guidelines:

- Inspection should be made weekly or after each rainfall event and repair or replacement should be made promptly as needed by the contractor.
- Inspect and realign berms as needed to prevent gaps between the sections.
- Accumulated silt should be removed after each rainfall event, and disposed of in a manner which shall not cause additional siltation.

TRIANGULAR FILTER DIKE
NOT TO SCALE

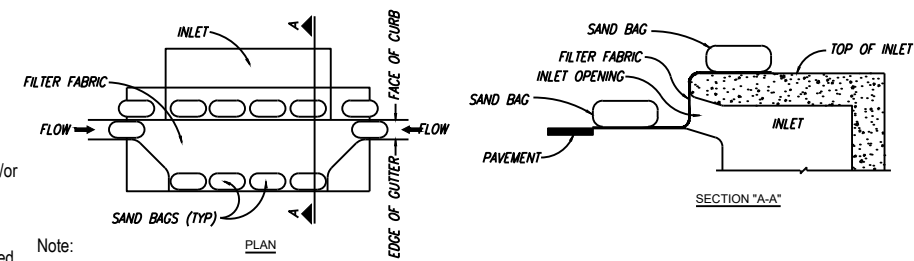

Note:

Filter fabric to extend 5'-0" beyond inlet opening, upstream of inlet. Terminate fabric in street gutter with sand bags placed in gutter flowline.

CURB INLET PROTECTION DETAIL
NOT TO SCALE

EROSION/SEDIMENTATION AND TREE PROTECTION NOTES

- The contractor to install and maintain erosion/sedimentation controls and tree/natural area protective fencing prior to any site preparation work (clearing, grubbing, grading, or excavation). Contractor to remove erosion/sedimentation controls at the completion of project and grass restoration.
- The placement of erosion/sedimentation controls to be in accordance with the approved erosion and sedimentation control plan and water pollution abatement plan. Deviations from the approved plan shall be submitted to and approved by the owner's representative.
- All disturbed areas to be restored as noted in the water pollution abatement plan.
- The seeding for erosion control to be applied over areas disturbed by construction as follows:
From September 15 to March 1, seeding to be with a combination of 2 pounds per 1,000 square feet of unhulled bermuda and 2 pounds per 1,000 square feet of winter rye with a purity of 95% with 90% germination.
From March 2, to September 14, seeding to be with hulled bermuda grass (cynodon dactylon) at a rate of 2 pounds per 1,000 square feet with a purity of 95% with 85% germination.
- The planted area to be irrigated or sprinkled in a manner that will not erode the topsoil, but will sufficiently soak the soil to a depth of four (4) inches. The irrigation to occur at 10-day intervals during the first two months. Rainfall occurrences of 1/2 inch or greater to postpone the watering schedule one week.
- Restoration to be acceptable when the grass has grown at least 1-1/2 inches high with 95% coverage, provided no bare spots larger than 25 square feet exist.
- A minimum of four (4) inches of topsoil to be placed in all areas disturbed by construction.
- The contractor to hydromulch or sod (as shown on plans) all exposed cuts and fills upon completion of construction, except where cuts are made in solid rock.
- Erosion and sedimentation controls to be installed or maintained in a manner which does not result in soil buildup within tree dripline.
- To avoid soil compaction, contractor shall not allow vehicular traffic, parking, or storage of equipment or materials in the tree dripline areas.
- Where a fence is closer than four (4) feet to a tree trunk, protect the trunk with strapped-on planking to a height of eight (8) feet (or to the limits of lower branching) in addition to the fencing.
- Trees to be removed in a manner which does not impact trees to be preserved.
- Any root exposed by construction activity to be pruned flush with the soil. Backfill root areas with good quality topsoil as soon as possible. If exposed root areas are not backfilled within two days, cover them with organic material in a manner which reduces soil temperature and minimizes water loss due to evaporation.
- Contractor to prune vegetation to provide clearance for structures, vehicular traffic, and equipment before damage occurs (ripping of branches, etc.). All finished pruning to be done according to recognized, approved standards of the industry (reference the "National Arborist Association pruning standards for shade trees").
- The contractor is to inspect the controls at weekly intervals and after every rainfall exceeding 1/4 inch to verify that they have not been significantly disturbed. Any accumulated sediment after a significant rainfall to be removed and placed in the owner designated spoil disposal site. The contractor to conduct periodic inspections of all erosion/sedimentation controls and to make any repairs or modifications necessary to assure continued effective operation of each device.
- Where there is to be an approved grade change, impermeable paving surface, tree well, or other such site development immediately adjacent to a protected tree, erect the fence approximately two to four feet (2'-4') behind the area in question.
- No above and/or below ground temporary fuel storage facilities to be stored on the project site.
- If erosion and sedimentation control systems are existing from prior contracts, owner's representative and the contractor to examine the existing erosion and sedimentation control systems for damage prior to construction. Any damage to preexisting erosion and sedimentation controls noted to be repaired at owners expense.
- Intentional release of vehicle or equipment fluids onto the ground is not allowed. Contaminated soil resulting from accidental spill to be removed and disposed of properly.

BID SET

NO.	DATE	REVISION	BY

© 2025 Kasberg, Patrick & Associates, LP
KPA Firm Registration Number F-510

Plot Date: 10/20/2025 11:42:39 AM
Plotted By: AJACOB

PROJECT NO. 24-179
DRAWN BY Aneena Jacob
DESIGNED BY Alvin R. Sutton III, P.E.
APPROVED BY [Signature]
DATE 10/20/2025



KASBERG, PATRICK & ASSOCIATES, LP
CONSULTING ENGINEERS
GEORGETOWN, TEXAS 78626

WILLAMSON COUNTY, TEXAS
BRUSHY CREEK REGIONAL TRAIL-DRAINAGE CORRECTION
EROSION-SEDIMENTATION & TREE PROTECTION NOTES AND DETAILS

SHEET NO. **G-04** OF **04** SHEETS

FILE: P:\Williamson County\2024\24-179 BRUSHY CREEK REGIONAL TRAIL-DRAINAGE CORRECTION\CAD\plans\DETAILS - MISC\DETAILS.dwg LAST SAVED: 8/19/2025 11:15:55 AM LAYOUT: DETAIL-01

**GUIDELINES FOR DESIGN AND INSTALLATION OF
TEMPORARY EROSION AND SEDIMENTATION CONTROLS**

TYPE OF STRUCTURE	REACH LENGTH	MAXIMUM DRAINAGE AREA	SLOPE
SILT FENCE	N/A	2 ACRES	0 - 10%
	200 FEET	2 ACRES	10 - 20%
	100 FEET	1 ACRE	20 - 30%
TRIANGLE FILTER DIKE	50 FEET	1/2 ACRE	> 30%
	100 FEET	1/2 ACRE	< 30% SLOPE
ROCK BERM *, **	50 FEET	1/4 ACRE	> 30% SLOPE
	500 FEET	< 5 ACRES	0 - 10%

* FOR ROCK BERM DESIGN WHERE PARAMETERS ARE OTHER THAN STATED, DRAINAGE AREA CALCULATIONS AND ROCK BERM DESIGN MUST BE SUBMITTED FOR REVIEW.

** HIGH SERVICE ROCK BERMS MAY BE REQUIRED IN AREAS OF ENVIRONMENTAL SIGNIFICANCE AS DETERMINED BY THE CITY OF GEORGETOWN.

TEMPORARY EROSION AND SEDIMENTATION CONTROL GUIDELINES		THE ARCHITECT/ENGINEER ASSUMES RESPONSIBILITY FOR APPROPRIATE USE OF THIS STANDARD.	
		SCALE: NTS	DRAWING NUMBER: EC01.1
DATE: 8/2024	DESIGNED BY: KPA	APPROVED BY: COGT	

NOTE: THIS SECTION IS INTENDED TO ASSIST THOSE PERSONS PREPARING WATER POLLUTION ABATEMENT PLANS (WPAP) OR STORM WATER POLLUTION PREVENTION PLANS (SW3P) THAT COMPLY WITH FEDERAL, STATE AND/OR LOCAL STORM WATER REGULATIONS.

- THE CONTRACTOR TO INSTALL AND MAINTAIN EROSION/SEDIMENTATION CONTROLS AND TREE/NATURAL AREA PROTECTIVE FENCING PRIOR TO ANY SITE PREPARATION WORK (CLEARING, GRUBBING, GRADING, OR EXCAVATION). CONTRACTOR TO REMOVE EROSION/SEDIMENTATION CONTROLS AT THE COMPLETION OF PROJECT AND GRASS RESTORATION.
- ALL PROJECTS WITHIN THE RECHARGE ZONE OF THE EDWARD'S AQUIFER SHALL SUBMIT A BEST MANAGEMENT PRACTICES AND WATER POLLUTION AND ABATEMENT PLAN TO THE TCEQ FOR APPROVAL PRIOR TO ANY CONSTRUCTION.
- THE PLACEMENT OF EROSION/SEDIMENTATION CONTROLS TO BE IN ACCORDANCE WITH THE APPROVED EROSION AND SEDIMENTATION CONTROL PLAN AND WATER POLLUTION ABATEMENT PLAN. DEVIATIONS FROM THE APPROVED PLAN MUST BE SUBMITTED TO AND APPROVED BY THE OWNER'S REPRESENTATIVE.
- ALL PLANTING SHALL BE DONE BETWEEN MAY 1 AND SEPTEMBER 15 EXCEPT AS SPECIFICALLY AUTHORIZED IN WRITING. IF PLANTING IS AUTHORIZED TO BE DONE OUTSIDE THE DATES SPECIFIED, THE SEED SHALL BE PLANTED WITH THE ADDITION OF WINTER FESCUE (KENTUCKY 31) AT A RATE OF 100lb/ACRE. GRASS SHALL BE COMMON BERMOUDA GRASS, HULLED, MINIMUM 82% PURE LIVE SEED. ALL GRASS SEED SHALL BE FREE FROM NOXIOUS WEED. GRADE "A" RECENT CROP, RECLEANED AND TREATED WITH APPROPRIATE FUNGICIDE AT TIME OF MIXING. SEED SHALL BE FURNISHED IN SEALED, STANDARD CONTAINERS WITH DEALER'S GUARANTEED ANALYSIS.
- ALL DISTURBED AREAS TO BE RESTORED AS NOTED IN THE WATER POLLUTION ABATEMENT PLAN.
- THE PLANTED AREA TO BE IRRIGATED OR SPRINKLED IN A MANNER THAT WILL NOT ERODE THE TOPSOIL, BUT WILL SUFFICIENTLY SOAK THE SOIL TO A DEPTH OF FOUR (4) INCHES. THE IRRIGATION TO OCCUR AT 10-DAY INTERVALS DURING THE FIRST TWO MONTHS TO INSURE GERMINATION AND ESTABLISHMENT OF THE GRASS. RAINFALL OCCURRENCES OF 1/2 INCH OR GREATER TO POSTPONE THE WATERING SCHEDULE ONE WEEK.
- RESTORATION TO BE ACCEPTABLE WHEN THE GRASS HAS GROWN AT LEAST 1-1/2 INCHES HIGH WITH 95% COVERAGE, PROVIDED NO BARE SPOTS LARGER THAN 25 SQUARE FEET EXIST.
- A MINIMUM OF FOUR (4) INCHES OF TOPSOIL TO BE PLACED IN ALL AREAS DISTURBED BY CONSTRUCTION.
- THE CONTRACTOR TO HYDROMULCH OR SOD (AS SHOWN ON PLANS) ALL EXPOSED CUTS AND FILLS UPON COMPLETION OF CONSTRUCTION.
- EROSION AND SEDIMENTATION CONTROLS TO BE INSTALLED OR MAINTAINED IN A MANNER WHICH DOES NOT RESULT IN SOIL BUILDUP WITHIN TREE DRIPLINE.
- TO AVOID SOIL COMPACTION, CONTRACTOR SHALL NOT ALLOW VEHICULAR TRAFFIC, PARKING, OR STORAGE OF EQUIPMENT OR MATERIALS IN THE TREE DRIPLINE AREAS.
- WHERE A FENCE IS CLOSER THAN FOUR (4) FEET TO A TREE TRUNK, PROTECT THE TRUNK WITH STRAPPED-ON PLANKING TO A HEIGHT OF EIGHT (8) FEET (OR TO THE LIMITS OF LOWER BRANCHING) IN ADDITION TO THE FENCING.
- TREES TO BE REMOVED IN A MANNER WHICH DOES NOT IMPACT TREES TO BE PRESERVED.
- ANY ROOT EXPOSED BY CONSTRUCTION ACTIVITY TO BE PRUNED FLUSH WITH THE SOIL. BACKFILL ROOT AREAS WITH GOOD QUALITY TOPSOIL AS SOON AS POSSIBLE. IF EXPOSED ROOT AREAS ARE NOT BACKFILLED WITHIN TWO DAYS, COVER THEM WITH ORGANIC MATERIAL IN A MANNER WHICH REDUCES SOIL TEMPERATURE AND MINIMIZES WATER LOSS DUE TO EVAPORATION.
- CONTRACTOR TO PRUNE VEGETATION TO PROVIDE CLEARANCE FOR STRUCTURES, VEHICULAR TRAFFIC, AND EQUIPMENT BEFORE DAMAGE OCCURS (RIPPING OF BRANCHES, ETC.). ALL FINISHED PRUNING TO BE DONE ACCORDING TO RECOGNIZED, APPROVED STANDARDS OF THE INDUSTRY (REFERENCE THE "NATIONAL ARBORIST ASSOCIATION PRUNING STANDARDS FOR SHADE TREES").
- THE CONTRACTOR IS TO INSPECT THE CONTROLS AT WEEKLY INTERVALS AND AFTER EVERY RAINFALL EXCEEDING 1/4 INCH TO VERIFY THAT THEY HAVE NOT BEEN SIGNIFICANTLY DISTURBED. ANY ACCUMULATED SEDIMENT AFTER A SIGNIFICANT RAINFALL TO BE REMOVED AND PLACED IN THE OWNER DESIGNATED SPOIL DISPOSAL SITE. THE CONTRACTOR TO CONDUCT PERIODIC INSPECTIONS OF ALL EROSION/SEDIMENTATION CONTROLS AND TO MAKE ANY REPAIRS OR MODIFICATIONS NECESSARY TO ASSURE CONTINUED EFFECTIVE OPERATION OF EACH DEVICE.
- WHERE THERE IS TO BE AN APPROVED GRADE CHANGE, IMPERMEABLE PAVING SURFACE, TREE WELL, OR OTHER SUCH SITE DEVELOPMENT IMMEDIATELY ADJACENT TO A PROTECTED TREE, ERECT THE FENCE APPROXIMATELY TWO TO FOUR FEET (2'-4') BEHIND THE AREA IN QUESTION.
- NO ABOVE AND/OR BELOW GROUND TEMPORARY FUEL STORAGE FACILITIES TO BE STORED ON THE PROJECT SITE.
- IF EROSION AND SEDIMENTATION CONTROL SYSTEMS ARE EXISTING FROM PRIOR CONTRACTS, OWNER'S REPRESENTATIVE AND THE CONTRACTOR TO EXAMINE THE EXISTING EROSION AND SEDIMENTATION CONTROL SYSTEMS FOR DAMAGE PRIOR TO CONSTRUCTION. ANY DAMAGE TO PREEXISTING EROSION AND SEDIMENTATION CONTROLS NOTED TO BE REPAIRED AT OWNERS EXPENSE.
- INTENTIONAL RELEASE OF VEHICLE OR EQUIPMENT FLUIDS ONTO THE GROUND IS NOT ALLOWED. CONTAMINATED SOIL RESULTING FROM ACCIDENTAL SPILL TO BE REMOVED AND DISPOSED OF PROPERLY.

EROSION AND SEDIMENTATION AND TREE PROTECTION NOTES		THE ARCHITECT/ENGINEER ASSUMES RESPONSIBILITY FOR APPROPRIATE USE OF THIS STANDARD.	
		SCALE: NTS	DRAWING NUMBER: EC01.2
DATE: 8/2024	DESIGNED BY: KPA	APPROVED BY: COGT	

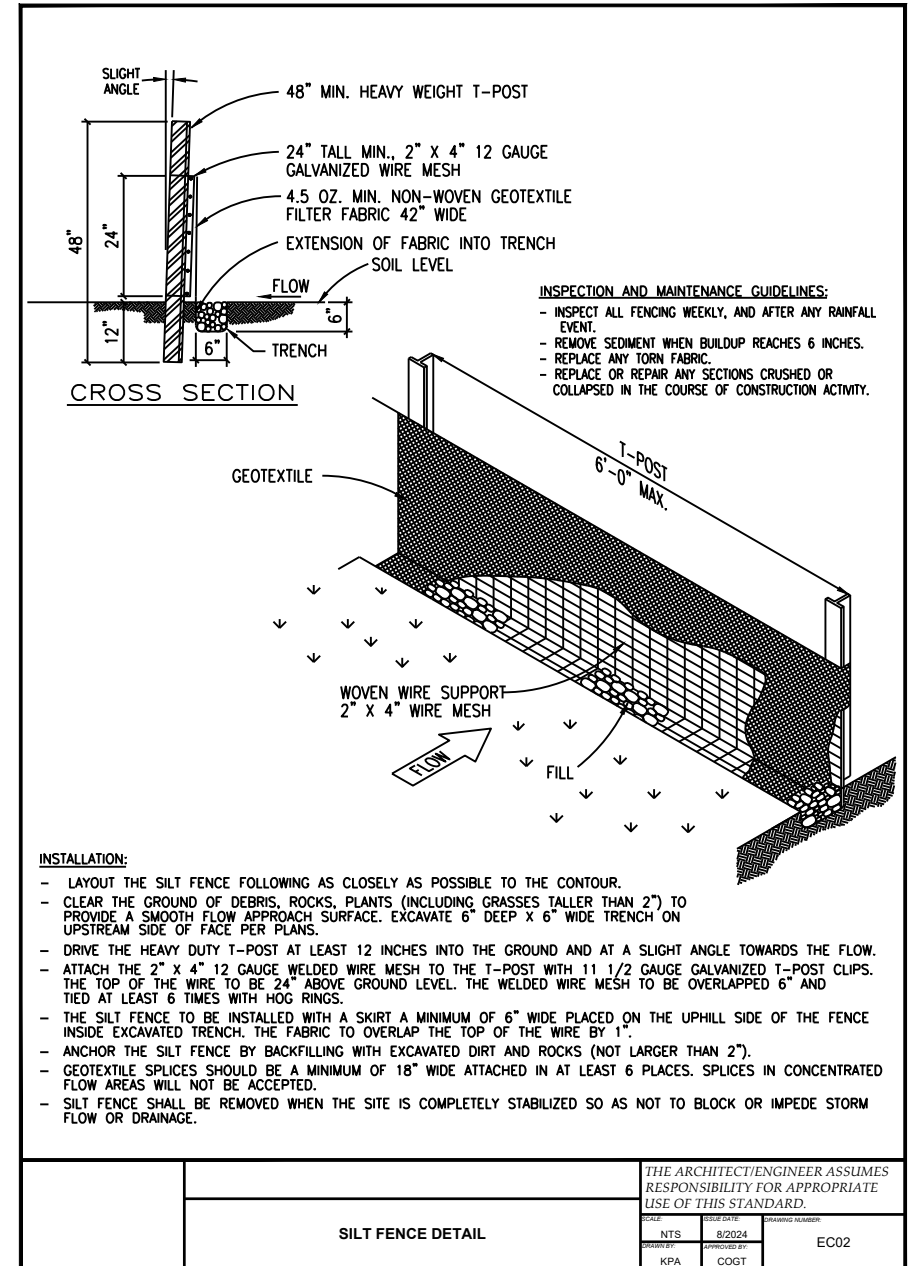

BID SET

NO.	DATE	REVISION	BY

© 2025 Kasberg, Patrick & Associates, LP
KPA Firm Registration Number F-510

Plot Date: 10/20/2025 11:42:59 AM
Plotted By: AJACOB

PROJECT NO. 24-179
DRAWN BY Aneena Jacob
DESIGNED BY Alvin R. Sutton III, P.E.
APPROVED BY *[Signature]*
DATE 10/20/2025

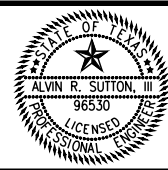

KASBERG, PATRICK & ASSOCIATES, LP
CONSULTING ENGINEERS
GEORGETOWN, TEXAS 78626

WILLAMSON COUNTY, TEXAS
BRUSHY CREEK REGIONAL TRAIL-DRAINAGE CORRECTION
DETAIL SHEETS
DETAIL-01

SHEET NO. **D-01** OF **03** SHEETS

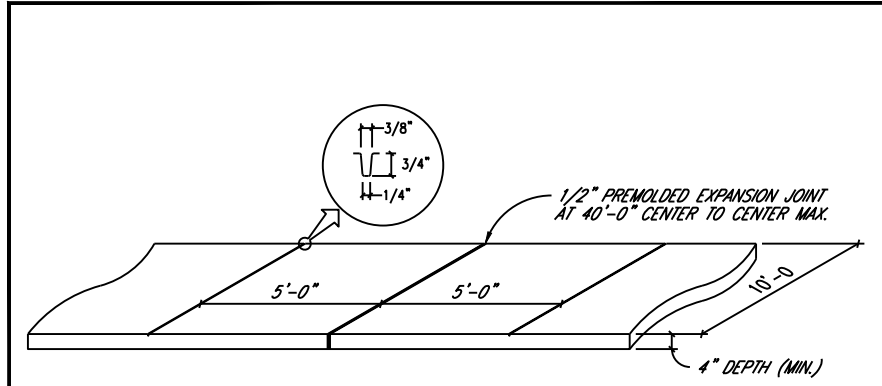

TYPE I - AS REQUIRED FOR SINGLE FAMILY, DUPLEXES AND TOWNHOUSES, TRIPLEXES AND QUADRAPLEXES.
 TYPE II - AS REQUIRED FOR MULTI-FAMILY, OTHER NON-RESIDENTIAL USES AND PARKING LOTS/STRUCTURES.
 ALL THOROUGHFARES (COLLECTOR AND ABOVE) REQUIRE TYPE II.

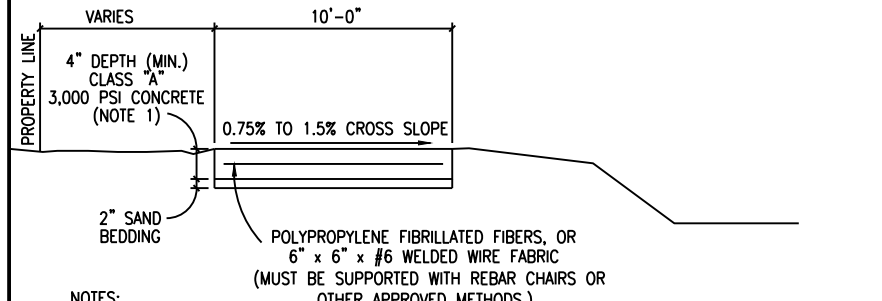

- NOTES:
- STANDARD LOCATION OF SIDEWALK SHALL BE IN CONFORMANCE WITH THE UDC.
 - SIDEWALK SHALL CONFORM TO CURRENT TDLR/TAS STANDARDS.
 - ALL SIDEWALKS SHALL BE SUBMITTED AND APPROVED BY THE REGISTERED ACCESSIBILITY SPECIALIST (RAS) AND ENGINEER OF RECORD.
 - ANY VARIANCE IN TEXTURE, GRADE OR ALIGNMENT SHALL BE APPROVED BY THE REGISTERED ACCESSIBILITY SPECIALIST (RAS) AND BY THE CITY ENGINEER.
 - SLIP DOWEL SHALL BE INSTALLED AT EVERY LONGITUDINAL EXPANSION JOINT (UNLESS OTHERWISE APPROVED BY THE CITY ENGINEER DURING ENGINEERING PLAN REVIEW PRIOR TO FINAL DESIGN).

THE ARCHITECT/ENGINEER ASSUMES RESPONSIBILITY FOR APPROPRIATE USE OF THIS STANDARD.	
DATE	ISSUE NUMBER
NTS	8/2024
DESIGNED BY	APPROVED BY
KPA	COGT
SD14	

SIDEWALK SECTION AND JOINT DETAIL

- NOTES:
- ALL WORK AND MATERIAL SHALL CONFORM TO ASTM A615, A615M, C309, AND D1752. BROOM FINISH EXPOSED SURFACE.
 - CONTRACTION JOINT SPACING 10' MAX.
 - EXPANSION JOINTS AS PER STD. ASTM D-1752.
 - 1/2" EXPANSION JOINT MATERIAL SHALL BE PROVIDED WHERE CURB IS ADJACENT TO SIDEWALK OR RIP-RAP.
 - ALL CONCRETE SHALL BE CLASS A, 3000 PSI.
 - ALL SURFACES THAT ARE CHIPPED OR OTHERWISE DAMAGED DURING CONSTRUCTION SHALL BE REPAIRED.
 - THE FOLLOWING SCHEME OF REINFORCEMENT SHALL BE REQUIRED. THE MANNER OF PLACEMENT AND LOCATION SHALL BE TO THE SATISFACTION OF THE ENGINEER OR THE CITY OF GEORGETOWN.
 - REINFORCING BARS SHALL BE LAPPED A MINIMUM OF 15 INCH.
 - REINFORCING BARS SHALL BE SUPPORTED WITH REBAR CHAIRS OR OTHER APPROVED METHODS.
 - REBAR SUPPORTS ARE NOT REQUIRED ON MACHINE PLACED CURB PROVIDED THAT REBAR IS PROPERLY GUIDED INTO THE CURB SECTION.

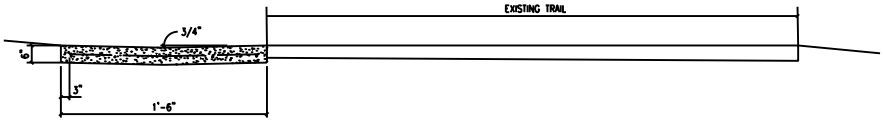

18" VALLEY GUTTER

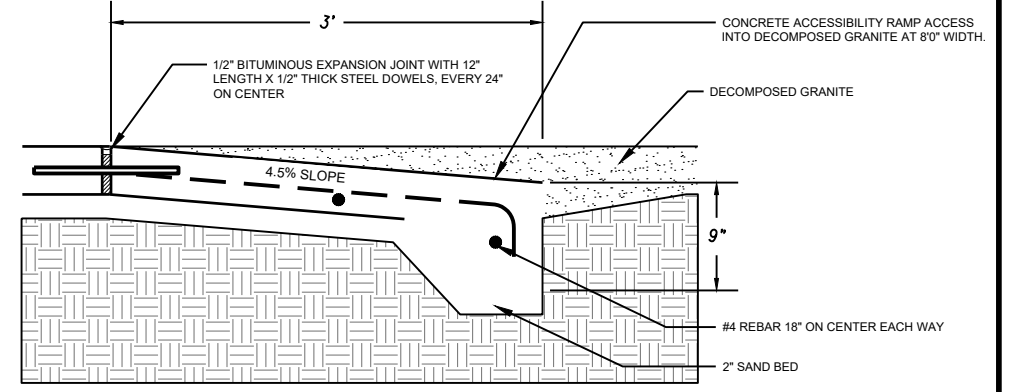

TRAIL CONNECTION DETAIL

BID SET

NO.	DATE	REVISION	BY

© 2025 Kasberg, Patrick & Associates, LP
 KPA Firm Registration Number F-510

Plot Date: 10/20/2025 11:43:00 AM
 Plotted By: AJACOB

PROJECT NO. 24-179
 DRAWN BY Aneena Jacob
 DESIGNED BY Alvin R. Sutton III, P.E.
 APPROVED BY *[Signature]*
 DATE 10/20/2025



KASBERG, PATRICK & ASSOCIATES, LP
 CONSULTING ENGINEERS
 GEORGETOWN, TEXAS 78626

WILLAMSON COUNTY, TEXAS
 BRUSHY CREEK REGIONAL TRAIL-DRAINAGE CORRECTION

DETAIL SHEETS
 DETAIL-02

SHEET NO. **D-02** OF **03** SHEETS

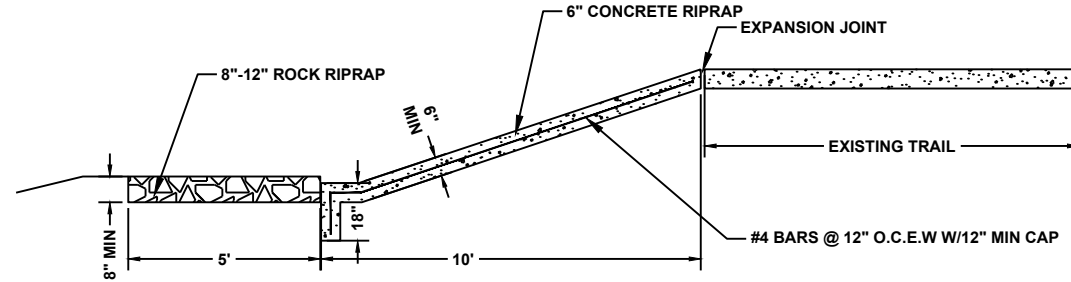

NOTES:

1. ALL ROCK RIPRAP SHALL CONFORM WITH TXDOT SPECIFICATION ITEM 432 UNLESS NOTED OTHERWISE.
2. OVER EXCAVATION IS SUBSIDIARY TO FURNISHING AND INSTALLING THIS WORK.
3. ALL DIMENSIONS SHOWN ARE MINIMUM.

NOTES:

1. ALL CONCRETE RIPRAP SHALL CONFORM WITH TXDOT SPECIFICATION ITEM 432 UNLESS NOTED OTHERWISE.
2. ALL CONCRETE SHALL BE A MINIMUM OF 3000 PSI.
3. STEEL REINFORCING SHALL BE #4ASTM A-615 GRADE 60 BARS 12" ON CENTER EACH WAY. 6X6 #6 WIRE MESH MAY BE SUBSTITUTED FOR #4 REBAR.
4. WHILE PLACING CONCRETE, STEEL REINFORCEMENT SHALL BE SUPPORTED OR PLACED TO MAINTAIN A MINIMUM OF 2" CLEAR SPACING WITH TOP AND BOTTOM OR SIDE CONCRETE SURFACES.

CONCRETE RIPRAP AND ROCK RIPRAP DETAIL

BID SET

NO.	DATE	REVISION	BY

© 2025 Kasberg, Patrick & Associates, LP
KPA Firm Registration Number F-510

Plot Date: 10/20/2025 11:43:01 AM
Plotted By: AJACOB

PROJECT NO. 24-179
DRAWN BY Aneena Jacob
DESIGNED BY Alvin R. Sutton III, P.E.
APPROVED BY *[Signature]*
DATE 10/20/2025



KASBERG, PATRICK & ASSOCIATES, LP
CONSULTING ENGINEERS
GEORGETOWN, TEXAS 78626

WILLAMSON COUNTY, TEXAS
BRUSHY CREEK REGIONAL TRAIL-DRAINAGE CORRECTION

DETAIL SHEETS
DETAIL-03

SHEET NO.
D-03 OF
03 SHEETS