

WILLIAMSON COUNTY, TEXAS

CHANGE ORDER NUMBER: 5

Contractor: Capital Excavation NTP Required: [X] Yes [] No

Project Name: East Wilco Highway Segment 2 Phase 1

Change Order Work Limits: Sta. 1196+26 to Sta. 1198+50

Type of Change(on federal-aid non-exempt projects): Minor (Major/Minor)

Reasons: 3L (3 Max. - In order of importance - Primary first)

Table with contract details: Award Date: 7/30/2024, Project Number: 24IFB59, Funding Source: P392, Roadway: E. Wilco Hwy, CSJ Number: N/A

Describe the work being revised:

3. County Convenience 3L: Revising safety work/measures desired by the County: Due to safety concerns at the newly constructed intersection, Williamson County has requested the installation of traffic signals as part of this project. This Change Order provides for the cost of temporary trailer-mounted signals to be utilized until the design and construction of permanent signals are completed.

Work to be performed in accordance with Items: See Attached

New or revised plan sheet(s) are attached and numbered: PS # 1, 2, 3

New Special Provisions/Specifications to the contract are attached: [] Yes [X] No

New Special Provisions to Item N/A No. N/A. Special Specification Item N/A are attached.

Each signatory hereby warrants that each has the authority to execute this Change Order (CO).

Contractor signature block and summary table. Summary table includes: Time Ext. #: N/A, Days added on this CO: 0, Amount added by this change order: \$140,314.80, Original Contract Amount: \$64,407,606.63, Total Change Orders To-Date: -\$1,729,539.84, Percent Change in Original Contract: -2.69%

RECOMMENDED FOR EXECUTION: [Signature] 12/4/2025 Senior Construction Engineer Date

RECOMMENDED FOR EXECUTION: [Signature] 12/8/2025 Department of Infrastructure Williamson County Date

[Signature] 12/8/2025 Program Manager Date

APPROVED: [Signature] Date Presiding Officer of the Williamson County Commissioners Court

N/A 3rd Party Signature Date

WILLIAMSON COUNTY, TEXAS

CHANGE ORDER NUMBER: 5

Project # 24IFB59

TABLE A: Force Account Work and Materials Placed into Stock

	LABOR	HOURLY RATE			HOURLY RATE

TABLE B: Contract Items:

ITEM	DESCRIPTION	UNIT	UNIT PRICE	ORIGINAL + PREVIOUSLY REVISED		ADD or (DEDUCT)	NEW		OVERRUN/ UNDERRUN
				QUANTITY	ITEM COST	QUANTITY	QUANTITY	ITEM COST	
6001 6001	PORTABLE CHANGEABLE MESSAGE SIGN	MO	\$4,030.00	0.00	\$0.00	6.00	6.00	\$24,180.00	\$24,180.00
636 6001	ALUMINUM SIGNS (TY A)	SF	\$53.00	0.00	\$0.00	18.00	18.00	\$954.00	\$954.00
644 6001	IN SM RD SN SUP&AM TY10BWG(1)SA(P)	EA	\$1,165.00	0.00	\$0.00	1.00	1.00	\$1,165.00	\$1,165.00
644 6076	REMOVE SM RD SN SUP&AM	EA	\$260.00	11.00	\$2,860.00	1.00	12.00	\$3,120.00	\$260.00
644 6078	REMOVE SM RD SN SUP&AM (SIGN ONLY)	EA	\$584.00	0.00	\$0.00	1.00	1.00	\$584.00	\$584.00
666 6048	REFL PAV MRK TY I (W)24"(SLD)(100MIL)	LF	\$8.35	407.00	\$3,398.45	36.00	443.00	\$3,699.05	\$300.60
666 6230	PAVEMENT SEALER 24"	LF	\$5.30	0.00	\$0.00	36.00	36.00	\$190.80	\$190.80
666 WC01	PAV SURF PREP FOR MRK (24")	LF	\$2.65	0.00	\$0.00	36.00	36.00	\$95.40	\$95.40
681 WC01	TEMP TRAF SIGNALS	MO	\$15,000.00	0.00	\$0.00	6.00	6.00	\$90,000.00	\$90,000.00
685 6004.1	INSTL RDSO FLSH BCN ASSM (SOLAR PWRD)	EA	\$12,355.00	0.00	\$0.00	1.00	1.00	\$12,355.00	\$12,355.00
999 WC06	TRAFFIC CONTROL	LS	\$3,500.00	0.00	\$0.00	1.00	1.00	\$3,500.00	\$3,500.00
500 WC01	MOBILIZATION - SIGNALS	LS	\$5,830.00	0.00	\$0.00	1.00	1.00	\$5,830.00	\$5,830.00
682 6003	VEH SIG SEC (12")(LED)(YEL)	EA	\$450.00	16.00	\$7,200.00	2.00	18.00	\$8,100.00	\$900.00
TOTALS					\$13,458.45			\$153,773.25	\$140,314.80

Williamson County Road Bond Program

**East Wilco Highway Segment 1 Phase 1
Williamson County Project No. 24IFB59**

Change Order No. 5

Reason for Change

This Change Order compensates the Contractor for installing portable traffic signals, along with signage at the intersection of CR 137 and East Wilco Highway per the request of Williamson County. This portable traffic signals will increase the safety of the traveling public while work continues in this area and the design and construction of the permanent signal is completed.

Following is a summary of new items required for this Change Order.

ITEM	DESCRIPTION	QTY	UNIT
6001 6001	PORTABLE CHANGEABLE MESSAGE SIGN	6	MO
636 6001	ALUMINUM SIGNS (TY A)	18	SF
644 6001	IN SM RD SN SUP&AM TY10BWG(1)SA(P)	1	EA
644 6078	REMOVE SM RD SN SUP&AM (SIGN ONLY)	1	EA
666 6230	PAVEMENT SEALER 24"	36	LF
666 WC01	PAV SURF PREP FOR MRK (24")	36	LF
681 WC01	TEMP TRAFFIC SIGNALS	6	MO
685 6004.1	INSTL RDSD FLSH BCN ASSM (SOLAR PWRD)	1	EA
999 WC06	TRAFFIC CONTROL	1	LS
500 WC01	MOBILIZATION – SIGNALS	1	LS

This Change Order results in a net increase of \$140,314.80 to the Contract amount, for an adjusted Contract total of \$62,678,066.79. The original Contract amount was \$64,407,606.63. As a result of this and all Change Orders to-date, \$1,729,539.84 has been deducted from the Contract, resulting in an 2.69% net decrease in the Contract cost. No additional days will be added to the Contract as a result of this Change Order.

HNTB Corporation

Oscar Salazar-Bueno, P.E.

Change Order Worksheet

Contract Name	East Wilco Hwy Seg 2 Ph 1	Solicitation #	24IFB59
Date awarded	7/30/2024		
Awarded Contract Amount		\$64,407,606.63	
			Percentage Change
Change order #1		\$41,168.11	0.06%
Change order #2		(\$261,915.65)	-0.41%
Change order #3		(\$1,686,657.10)	-2.62%
Change order #4		\$37,550.00	0.06%
Change order #5		\$140,314.80	0.22%
Total changes to date		<u>(\$1,729,539.84)</u>	<u>-2.69%</u>
Adjusted contract amount		\$62,678,066.79	(Running totals here)

CHANGE ORDER REASON(S) CODE CHART

<p>1. Design Error or Omission</p>	<p>1A. Incorrect PS&E 1B. Other</p>
<p>2. Differing Site Conditions (unforeseeable)</p>	<p>2A. Dispute resolution (expense caused by conditions and/or resulting delay) 2B. Unavailable material 2C. New development (conditions changing after PS&E completed) 2D. Environmental remediation 2E. Miscellaneous difference in site conditions (unforeseeable)(Item 9) 2F. Site conditions altered by an act of nature 2G. Unadjusted utility (unforeseeable) 2H. Unacquired Right-of-Way (unforeseeable) 2I. Additional safety needs (unforeseeable) 2J. Other</p>
<p>3. County Convenience</p>	<p>3A. Dispute resolution (not resulting from error in plans or differing site conditions) 3B. Public relations improvement 3C. Implementation of a Value Engineering finding 3D. Achievement of an early project completion 3E. Reduction of future maintenance 3F. Additional work desired by the County 3G. Compliance requirements of new laws and/or policies 3H. Cost savings opportunity discovered during construction 3I. Implementation of improved technology or better process 3J. Price adjustment on finished work (price reduced in exchange for acceptance) 3K. Addition of stock account or material supplied by state provision 3L. Revising safety work/measures desired by the County 3M. Other</p>
<p>4. Third Party Accommodation</p>	<p>4A. Failure of a third party to meet commitment 4B. Third party requested work 4C. Compliance requirements of new laws and/or policies (impacting third party) 4D. Other</p>
<p>5. Contractor Convenience</p>	<p>5A. Contractor exercises option to change the traffic control plan 5B. Contractor requested change in the sequence and/or method of work 5C. Payment for Partnering workshop 5D. Additional safety work/measures desired by the contractor 5E. Other</p>
<p>6. Untimely ROW/Utilities</p>	<p>6A. Right-of-Way not clear (third party responsibility for ROW) 6B. Right-of-Way not clear (County responsibility for ROW) 6C. Utilities not clear 6D. Other</p>



PO Box 1301
 Austin, TX 78767
 Email: Estimating@CapitalExcavation.com

Change Request # 16

Date: 9/4/2025

QuoteTo: Kyle McCoy

HNTB Round Rock

Project: EAST WILCO WAY SEC 2 PH 1 (1072)

Capital Project #: 1072

Description: Portable Traffic Signal CR 1387

Item	Description	Quantity	Unit	Unit Price	Amount
	PORTABLE CHANGEABLE MESSAGE SIGN (2 each)	6.00	MO	4,030.00	24,180.00
	ALUMINUM SIGNS (TY A)	18.00	SF	53.00	954.00
	IN SM RD SN SUP&AM TY10BWG(1)SA(P)	1.00	EA	1,165.00	1,165.00
	REMOVE SM RD SN SUP&AM	1.00	EA	260.00	260.00
	REMOVE SM RD SN SUP&AM (SIGN ONLY)	1.00	EA	584.00	584.00
	REFL PAV MRK TY I (W)24"(SLD)(100MIL)	36.00	LF	8.35	300.60
	PAVEMENT SLER 24"	36.00	LF	5.30	190.80
	PAV SURF PREP FOR MRK (24")	36.00	LF	2.65	95.40
	TEMP TRAF SIGNALS (4 each)	6.00	MO	15,000.00	90,000.00
	INSTL RDS FL SH BCN ASSM (SOLAR PWRD)	1.00	EA	12,355.00	12,355.00
	TRAFFIC CONTROL	1.00	LS	3,500.00	3,500.00
	MOBILIZATION	1.00	LS	5,830.00	5,830.00
	VEH SIG SEC (12")LED(YEL)	2.00	EA	\$450	\$900.00
				530.00	1,060.00

GRAND TOTAL

\$140,314.80 ~~140,174.00~~

Scope: Pricing to implement temporary portable signals at the intersection of E Wilco Hwy and CR 137 as shown on the attached plan sheets.

Capital Excavation Requests an additional : day(s)

FILENAME: p:\kh-pw\ben\kimley.com\kh-pw-01\Documents\01 Active Projects\TS-AUS-068501539 - Wilco EWH - CR 137\DesignData\4 - Design\Plan Set\8. Traffic\CR137_SIG_QUANTITIES_00.dgn
 PLOTTED: 8/12/2025 8:55:53 AM

ESTIMATED QUANTITIES			
ITEM #	DESCRIPTION	UNIT	QUANTITY
0503-7002	PORTABLE CHANGEABLE MESSAGE SIGN	EA	2
0636-7001	ALUMINUM SIGNS (TY A)	SF	18
0644-7001	IN SM RD SN SUP&AM TY10BWG(1)SA(P)	EA	1
0644-7073	REMOVE SM RD SN SUP&AM	EA	1
0644-7075	REMOVE SM RD SN SUP&AM (SIGN ONLY)	EA	1
0666-7036	REFL PAV MRK TY I (W) 24" (SLD) (100MIL)	LF	36
0666-7352	PAVEMENT SLER 24"	LF	36
0678-7008	PAV SURF PREP FOR MRK (24")	LF	36
0681-7001	TEMP TRAF SIGNALS	EA	1
*	PORTABLE TRAFFIC SIGNAL	EA	4
0682-7003	VEH SIG SEC (12")LED(YEL)	EA	2
0685-7004	INSTL RDSB FLSH BCN ASSM (SOLAR PWRD)	EA	1

* THIS ITEM WILL NOT BE PAID FOR DIRECTLY BUT SHALL BE CONSIDERED SUBSIDIARY TO ITEM 681. THE QUANTITY IS SHOWN HERE FOR CONTRACTOR'S INFORMATION ONLY.

Kimley»Horn F-928



E WILCO HWY & CR 137

SUMMARY OF QUANTITIES

SHEET 1 OF 1

FED. RD. DIV. NO.	FEDERAL AID PROJECT NO.	HIGHWAY NO.	
6			
STATE	DIST.	COUNTY	SHEET NO.
TEXAS	AUS	WILLIAMSON	1
CONT.	SECT.	JOB	

FILENAME: pw://kh-pw.dent/kimley-horn.com/kh-pw-01/Documents/01 Active Projects/TS-AUS-068501539 - Wilco EHW - CR 137/DesignData/4 - Design/Plan Set/8. Traffic/CR137_SIG_PTTs.01.dgn
 PLOTTED: 8/12/2025 8:56:02 AM

PROPOSED SIGNAL HEADS

5-SECTION VERTICAL
12" SIGNAL HEAD

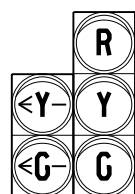

⑧

3-SECTION VERTICAL
12" SIGNAL HEAD



① ② ③ ④ ⑤ ⑥ ⑦

NOTES:

1. TWO PORTABLE CHANGEABLE MESSAGE SIGNS (PCMS) TO BE INSTALLED APPROXIMATELY 1150FT IN ADVANCE FROM NORTHBOUND AND 700FT IN ADVANCE FROM SOUTHBOUND APPROACH STOP-BAR.
2. PORTABLE CHANGEABLE MESSAGE SIGN TO READ "TRAFFIC SIGNAL AHEAD PREPARE TO STOP".
3. PORTABLE CHANGEABLE MESSAGE SIGN TO REMAIN IN USE FROM TIME THAT TRAILER MOUNTED SIGNALS ARE ACTIVATED UNTIL AFTER COMPLETION OF PERMANENT TRAFFIC SIGNAL.

LEGEND

- TEMP PORTABLE TRAILER SIGNAL
- CHANNELIZING DEVICE (BARREL)
- TEMP SIGNAL HEAD
- SIGNAL HEAD ID
- DIRECTION OF TRAFFIC
- RIGHT-OF-WAY (R.O.W.)

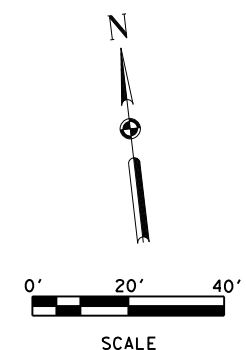
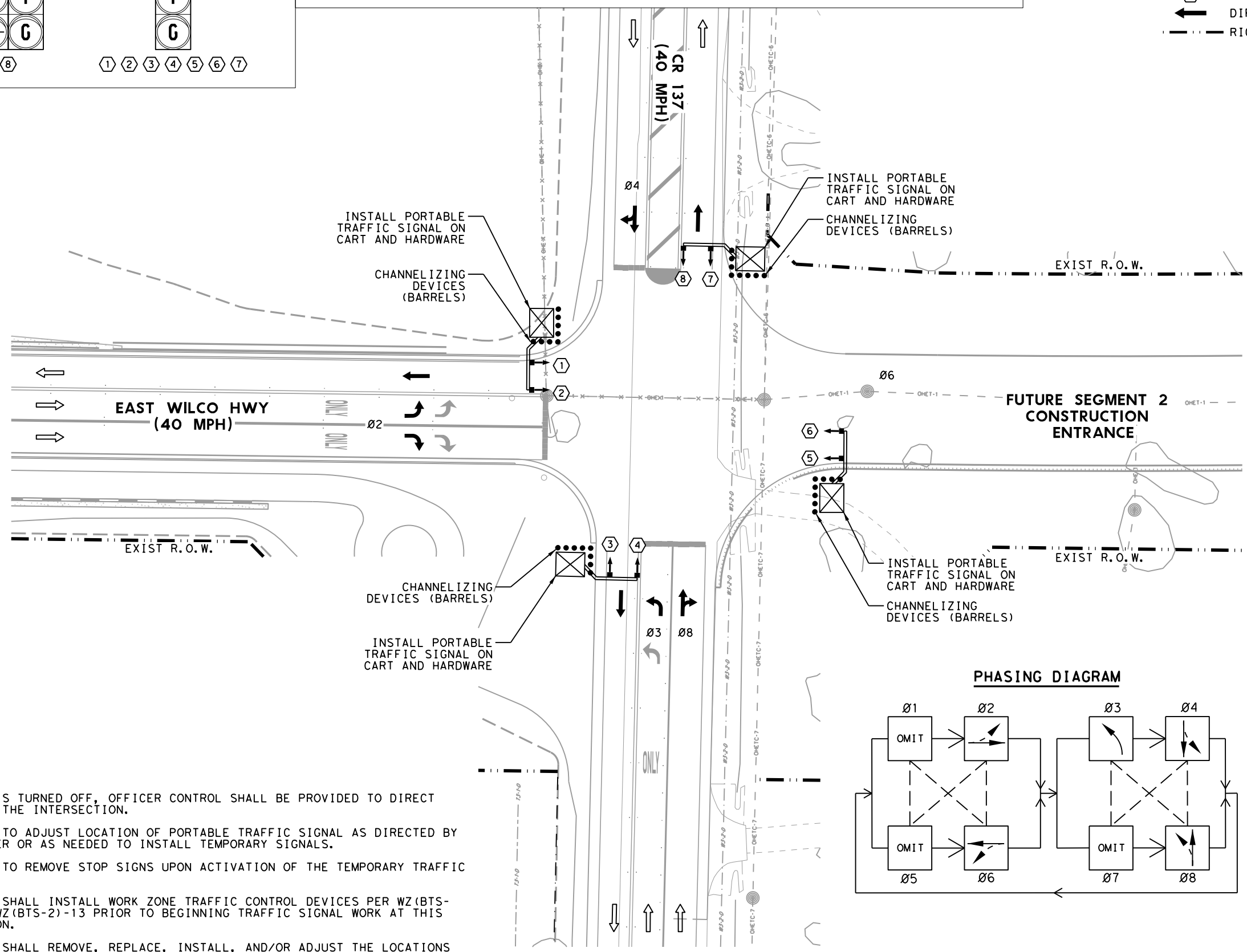

Matthew Gaal 8/12/2025

NOTES:

1. IF SIGNAL IS TURNED OFF, OFFICER CONTROL SHALL BE PROVIDED TO DIRECT TRAFFIC AT THE INTERSECTION.
2. CONTRACTOR TO ADJUST LOCATION OF PORTABLE TRAFFIC SIGNAL AS DIRECTED BY THE ENGINEER OR AS NEEDED TO INSTALL TEMPORARY SIGNALS.
3. CONTRACTOR TO REMOVE STOP SIGNS UPON ACTIVATION OF THE TEMPORARY TRAFFIC SIGNAL.
4. CONTRACTOR SHALL INSTALL WORK ZONE TRAFFIC CONTROL DEVICES PER WZ(BTS-1)-13 AND WZ(BTS-2)-13 PRIOR TO BEGINNING TRAFFIC SIGNAL WORK AT THIS INTERSECTION.
5. CONTRACTOR SHALL REMOVE, REPLACE, INSTALL, AND/OR ADJUST THE LOCATIONS OF STOP BAR PAVEMENT MARKINGS AS DIRECTED BY THE ENGINEER.

PHASING DIAGRAM

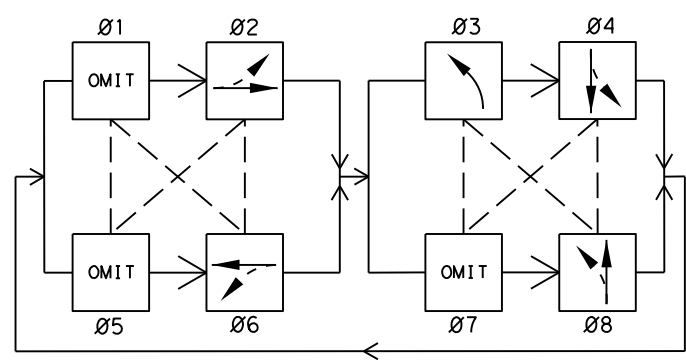

Kimley»Horn F-928



E WILCO HWY & CR 137

TEMPORARY PORTABLE TRAFFIC SIGNALS

SHEET 1 OF 1

FED. RD. DIV. NO.	FEDERAL AID PROJECT NO.	HIGHWAY NO.
6		
STATE	DIST.	COUNTY
TEXAS	AUS	WILLIAMSON
CONT.	SECT.	JOB
		SHEET NO. 2

FILENAME: pw://kn-pw.bentley.com/kh-pw-01/Documents/01 Active Projects/TS-AUS-068501539 - Wilco EHW - CR 137/DesignData/4 - Design/Plan Set/8. Traffic/CR137_SIG_PLM.01
 PLOTTED: 8/12/2025 8:56:09 AM

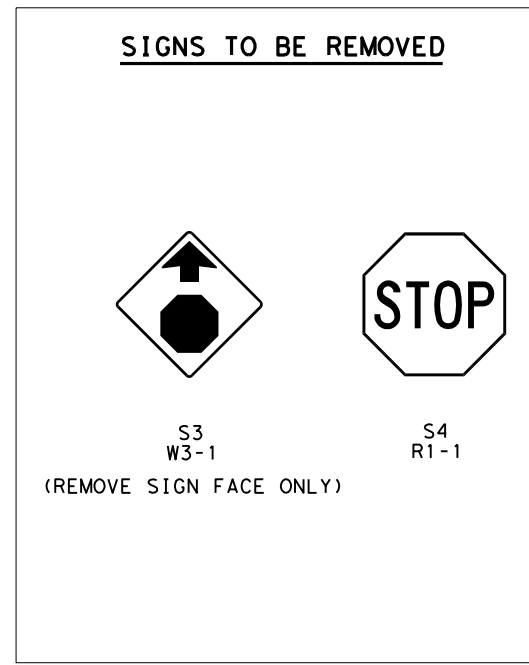
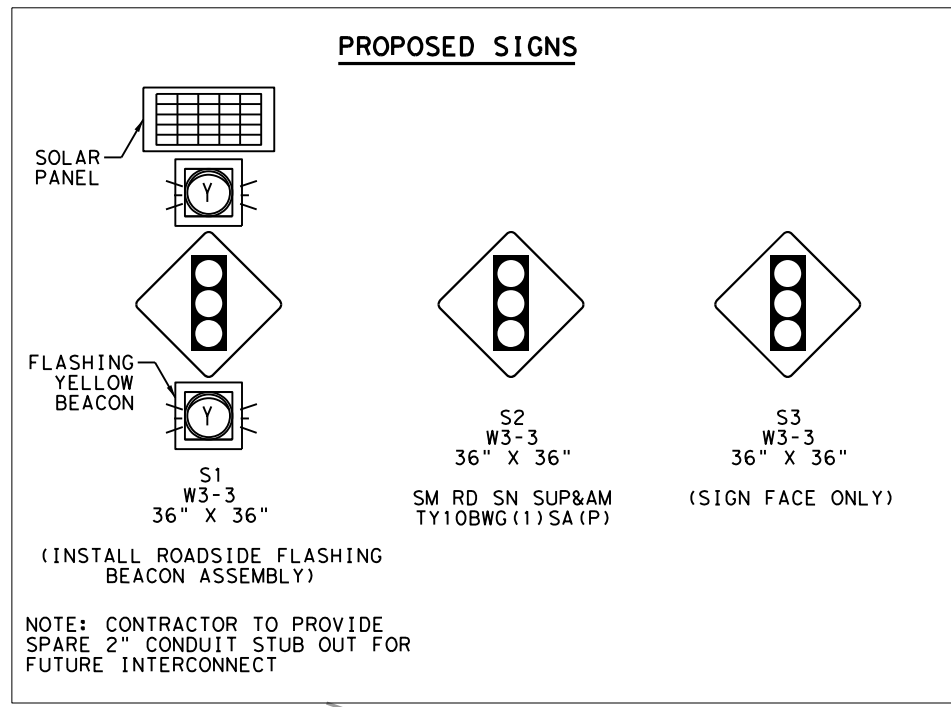

LEGEND

Symbol	Description	QTY
	TEMP PORTABLE TRAILER SIGNAL	
	CHANNELIZING DEVICE (BARREL)	
	REFL PAV MRK TY I (W)24" (SLD) (100MIL)	36 LF
	POST MOUNTED SIGN	3 EA
	DIRECTION OF TRAFFIC	
	RIGHT-OF-WAY (R.O.W.)	

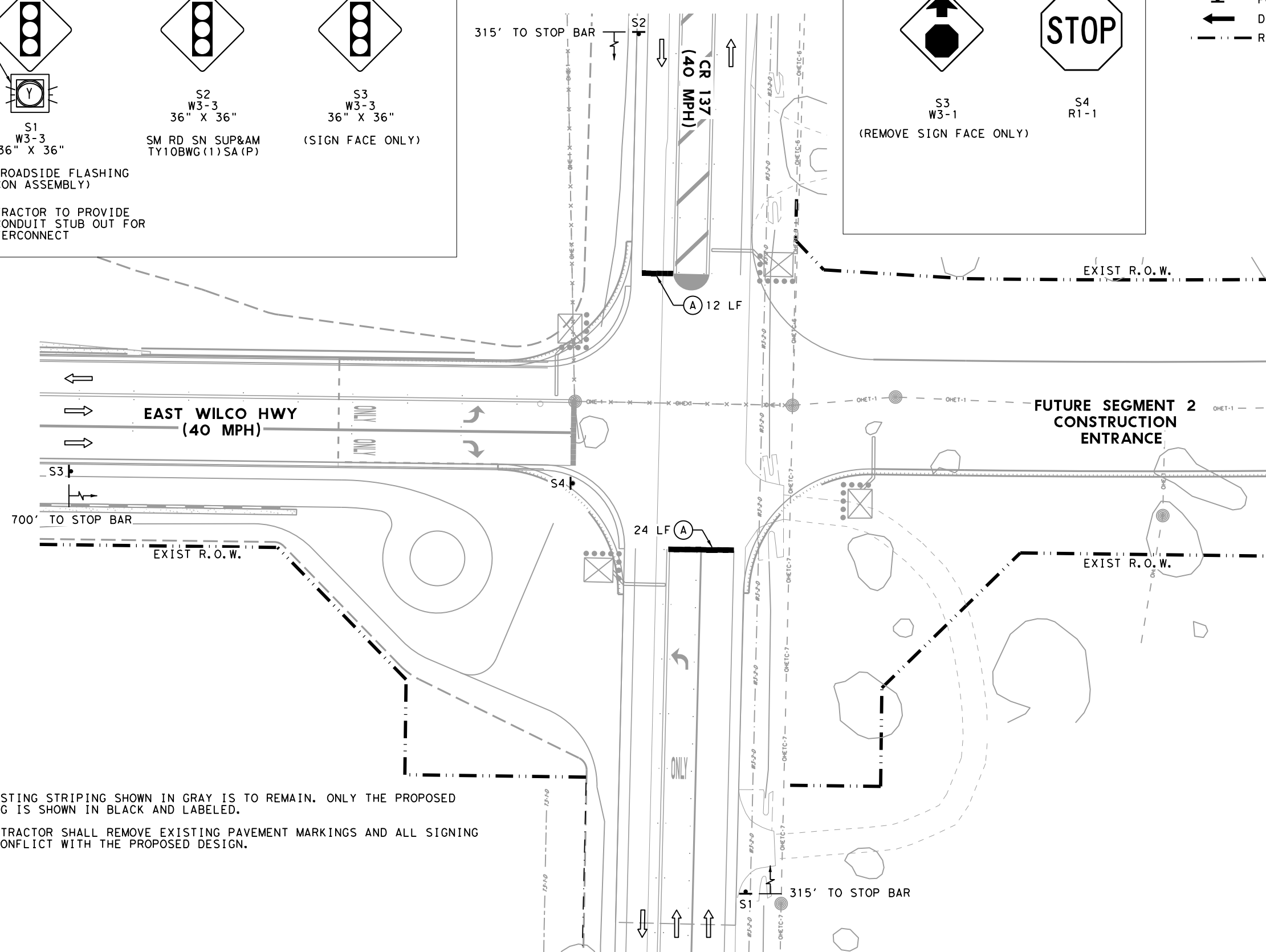

- ### NOTES:
1. THE EXISTING STRIPING SHOWN IN GRAY IS TO REMAIN. ONLY THE PROPOSED STRIPING IS SHOWN IN BLACK AND LABELED.
 2. THE CONTRACTOR SHALL REMOVE EXISTING PAVEMENT MARKINGS AND ALL SIGNING WHICH CONFLICT WITH THE PROPOSED DESIGN.

STATE OF TEXAS
 MATTHEW A. GAAL
 140753
 LICENSED PROFESSIONAL ENGINEER
Matthew Gaal
 8/12/2025

Kimley»Horn F-928

WILCO TEXAS

E WILCO HWY & CR 137

PROPOSED SIGNING & PAVEMENT MARKINGS LAYOUT

SHEET 1 OF 1

FED. RD. DIV. NO.	FEDERAL AID PROJECT NO.	HIGHWAY NO.
6		
STATE	DIST.	COUNTY
TEXAS	AUS	WILLIAMSON
CONT.	SECT.	JOB
		SHEET NO. 3