

NOTICE TO THE PUBLIC
WILLIAMSON COUNTY COMMISSIONERS COURT
Commissioners Courtroom
710 S. Main Street, Georgetown
March 10, 2026
9:30 A.M.

The Commissioners Court of Williamson County, Texas will meet in Regular Session at the above location, date, and time to consider the items set forth below. It is the intent of the Commissioners Court to have a quorum physically present at the meeting. Up to two (2) Commissioners Court members may participate by videoconference call in accordance with the Texas Open Meetings Act.

1. Review and approval of minutes.
2. Hear County Auditor concerning invoices, bills, Quick Check Report, wire transfers and electronic payments submitted for payment and take appropriate action including, but not limited to approval for payment provided said items are found by the County Auditor to be legal obligations of the county.

Public Comment Period for Agenda Items. The Commissioners Court will conduct a Public Comment Period to allow members of the public, who have properly submitted a Public Participation Form, to address the Commissioners Court regarding specific Agenda Items that are on the Commissioners Court's Agenda. During such Public Comment Period, speakers shall be limited to a maximum of three (3) minutes to make his or her remarks regarding an Agenda Item. Each member of the public who appears before the Commissioners Court to address the Commissioners Court regarding more than one (1) Agenda Item on the Commissioners Court's Agenda shall be limited to a cumulative maximum of five (5) minutes to make his or her remarks for all such Agenda Items. The maximum overall discussion time allowed for an Agenda Item, regardless of the number of members of the public wishing to address the Court on such Agenda Item, shall be limited to thirty (30) minutes. Speaking time, to the extent possible, will be evenly allocated among speakers should more than ten (10) speakers desire to speak on the same Agenda Item. In matters of exceptional interest, the Commissioners Court may, by majority vote, lengthen the maximum overall public discussion time allowed on a particular Agenda Item. The Presiding Officer of the Commissioners Court reserves the right to conduct public comment regarding an Agenda Item at the time in which the item is called for the Commissioners Court's consideration as opposed to including such public comments during this Public Comment Period.

CONSENT AGENDA

The Consent Agenda includes non-controversial and routine items that the Court may act on with one single vote. The Judge or a Commissioner may pull any item from the consent agenda in order that the court discuss and act upon it individually as part of the Regular Agenda.
(Items 3 –23)

3. Discuss, consider and take appropriate action on a line item transfer for various departments to cover shortfalls and enable payment of the workers' compensation invoice.
4. Discuss, consider and take appropriate action on approving compensation changes, position title changes, position grade changes, and any corresponding line item transfers.
5. Discuss, consider and take appropriate action to approve Justice of the Peace, Pct. 1, February 2026 Monthly Report in compliance with Code of Crim. Proc. § 103.005.
6. Discuss, consider, and take appropriate action on the appointment of Lauren Griffith as Deputy Constable for Constable Precinct 1 pursuant to Texas Local Government Code 86.011.

7. Discuss, consider, and take appropriate action regarding the 2025 Racial Profiling Report for Constable 4.
8. Discuss, consider and take any necessary action to approve an Order for Interment by cremation of the deceased (Jerry Wayne Ritzell) who passed away in Williamson County, Texas, where the County has discretion to inter, pursuant to Tex. Health & Safety Code § 711.002(e), and authorize Beck Funeral Home to move forward with interment.
9. Discuss, consider and take action on Subrecipient Agreements between Williamson County and Habitat for Humanity of Williamson County, Key2Free and Operation Liberty Hill for Community Development Block Grant funding.
10. Discuss, consider, and take appropriate action on approving and ratifying the Moving Services Contract #2026-165 between Williamson County and Central Transportation Systems for election equipment moving service in the amount of \$32,850.00 and authorizing the execution of the service contract pursuant to TX SmartBuy Contract #TXMAS-22-96201.
11. Discuss, consider, and take appropriate action on approving a Silver Maintenance Agreement with Quadiant USA Inc. for the DS40i Folder Inserter, in the amount of \$1,675.31, and authorizing the execution of the Agreement.
12. Discuss, consider, and take appropriate action on authorizing the Purchasing Agent to advertise and receive sealed responses for qualifications for Jail Inmate Dental Services, under RFSQ #26RFSQ31.
13. Discuss, consider, and take appropriate action on authorizing the Purchasing Agent to advertise and receive sealed solicitations for Pharmaceuticals and Clinic Supplies for the Williamson County Animal Shelter, under IFB #26IFB24.
14. Discuss, consider, and take appropriate action on approving Addendum #2026-157 between Williamson County and CDW Government, LLC for Engineering and Consulting Services for as-needed support in the amount of \$10,200 and authorizing the execution of the addendum pursuant to DIR Contract #DIR-CPO-5176.
15. Discuss, consider, and take appropriate action on authorizing the Purchasing Agent to advertise and receive sealed responses for PLAE, Planner, Landscape Architecture, Architecture & Engineer Pool, under RFSQ # 26RFSQ28.
16. Discuss, consider, and take appropriate action authorizing funding in the amount of \$44,913 from the Williamson County Community Recreation Facility Fund to construct repairs to the parking lot at the Schwertner Community Center.
17. Discuss, consider, and take appropriate action on approving the Agreement of Construction Services No. 2026-177 between Williamson County and J.T. Vaughn Construction, LLC for the Schwertner Community Parking Lot in the not-to-exceed amount of Forty-Four Thousand Nine Hundred and Thirteen Dollars (\$44,913.00) pursuant to OMNIA Cooperative Contract #R241607 and authorize execution of the agreement.
18. Discuss, consider and take appropriate action regarding change order #1 for Project 25IFB56 CR 313 Reconstruction.
19. Discuss, consider, and take appropriate action on approval of the Revised Preliminary Plat for the Reserve at North Haven Subdivision (revision 1) – Precinct 2.
20. Discuss, consider, and take appropriate action on approval of the Replat of Lots 20-22 Section 3, Lost River Ranches Subdivision – Precinct 3.

- 21. Discuss, consider, and take appropriate action on authorizing the Purchasing Agent to advertise and receive sealed responses for IFB North Barker Street, under IFB #26IFB33. The funding source is P689.
- 22. Discuss, consider, and take appropriate action on Work Authorization No. 1 to the On-Call Materials Testing (CR 110N) contract, dated September 11, 2024, between Williamson County and HVJ South Central Texas – M&J, Inc. relating to the 2023 Road Bond Program.
- 23. Discuss, consider, and take appropriate action on Work Authorization No. 13 to the On-Call Environmental Services (Ronald Reagan, Segment C1) contract, dated May 9, 2024, between Williamson County and SWCA, Incorporated dba SWCA Environmental Consultants relating to the 2023 Road Bond Program.

REGULAR AGENDA

- 24. Discuss, consider and take appropriate action on approving a Resolution recognizing Alan McMillin for his years of dedicated service to Williamson County as an American Red Cross volunteer and partner to the Williamson County Office of Emergency Management.
- 25. Hear a presentation on colorectal cancer and discuss, consider and take appropriate action on naming the month of March 2026 as "National Colorectal Cancer Awareness Month" in Williamson County.
- 26. Discuss, consider and take appropriate action on an alternate vehicle replacement schedule for the Office of Emergency Management and Fire Marshal Office response vehicles as identified in the attached.
- 27. Discuss, consider and take appropriate action on a line item transfer for the District Attorney's Office.

Fiscal Impact

From/To	Acct No.	Description	Amount
FROM	0100-0440-001100	Dist Atty/FT Salary	\$22,343
TO	0100-0440-004100	Dist Atty/Prof Svcs	\$22,343

- 28. Discuss, consider and take appropriate action on a line item transfer for the District Attorney's Office.

Fiscal Impact

From/To	Acct No.	Description	Amount
FROM	0100-0409-004100	Non Dept/Prof Svcs	\$145,000
TO	0100-0440-004100	Dist Atty/Prof Svcs	\$145,000

- 29. Discuss, consider, and take appropriate action on adopting the Williamson County Local Alcohol Distance Regulations to enact regulations applicable in the unincorporated area of Williamson County, Texas prohibiting the sale of alcoholic beverages within certain distances of churches, public or private schools, and public hospitals in accordance with Texas Alcohol Beverage Code Section 109.33.
- 30. Discuss, consider, and take appropriate action on authorizing the Purchasing Agent to advertise and receive sealed responses for Food Truck Management and Scheduling Services for Administrative Building, under RFP #26RFP34. There is no cost to Williamson County for this service. The added fee for service will be paid for by County employees as they order meals.

31. Discuss, consider and take appropriate action authorizing the Williamson County Sheriff's Office to apply for funding through the Office of the Governor's FY2026 Urban Area Security Initiative Federal Grant Program.
32. Discuss, consider, and take appropriate action on approving a MOU between Williamson County Emergency Medical Services and WellMed and authorizing the County Judge to sign the same and any necessary related documents.
33. Discuss, consider and take appropriate action for Juvenile Services to accept a \$49,697.00 grant through Texas Parks and Wildlife to provide outdoor programs for youth.
34. Discuss, consider, and take appropriate action on approving Purchase #2026-169 between Williamson County and Immix Technology, Inc. for UKG timekeeping software in the amount of \$190,680.00 and authorizing the execution of the purchase pursuant to DIR Contract #DIR-CPO-5688.
35. Discuss, consider, and take appropriate action on approving Contract #2026-174 between Tyler Technologies and Williamson County for the Annual Maintenance and SaaS Subscription in the amount of \$649,503.14, utilizing the Sourcewell Cooperative Contract #060624-TTI, and authorizing the execution of the contract.
36. Discuss, consider, and take appropriate action to approve the Service Agreement #2026-176 with CDW Government LLC for the Active Directory Modernization and User/Server Migration Services in the amount of \$197,590.00, under the Omnia National Cooperative Contract #R210401, and authorizing the execution of the agreement.
37. Discuss, consider, and take appropriate action on authorizing the Purchasing Agent to advertise and for contractors to provide Competitive Sealed Proposals for the Jail South AHU Replacement under RFCSP #26RFCSP29, and approving, in the public interest, assigning the price criteria a weighted value of not less than 36.9 percent of the total weighted value of all selection criteria.
38. Discuss, consider, and take appropriate action regarding Change Order No. 1R in the amount of \$204,217.89 for Project 25RFCSP50 Jester Annex HVAC Rooftop Unit (RTU) Replacement (Trimbuilt Construction, Inc.)
39. Discuss, consider, and take appropriate action to amend the executed Master Service Agreement #2026-021 with Johnson Controls Fire Protection LP between Williamson County and Facilities Management, previously approved by the Commissioners Court on the December 16, 2025, agenda, Item 31, and authorize execution of the amendment.
40. Discuss, consider and take appropriate action regarding the temporary road closure of CR 417 near CR 418 starting Tuesday, March 17, 2026, continuing through Friday, May 1, 2026, and on approval of a temporary diversion plan for traffic during the closure.
41. Discuss, consider and take appropriate action on approving a license agreement with The Meadows at Chandler Creek MUD for Tiger Trail – Precinct 1.
42. Discuss, consider, and take appropriate action on awarding IFB #26IFB12 to Aaron Concrete Contractors, LLC for the FM734 at Rattan Creek project for Road & Bridge/HNTB in the amount of \$1,239,349.71 and authorize execution of this agreement, contingent upon TXDOT concurrence. The funding source is P627.
43. Discuss, consider and take appropriate action on a possession and use agreement for transportation purposes with CDJ & Lee, LLC to acquire 9.276 AC and 2.227 AC needed as right of way on the Ronald Reagan Segment D project (Parcel 42).
44. Discuss, consider and take appropriate action on a real estate contract with Hjalmar, LLC, a Texas limited liability company, to acquire 5.387 AC needed as right of way and 0.0662 AC needed as a utility easement for the Corridor A2 project (Parcel 34).

EXECUTIVE SESSION

"The Commissioners Court for Williamson County reserves the right to adjourn into executive session at any time during the course of this meeting to discuss any of the matters listed above, as authorized by Texas Government Code Sections 551.071 (Consultations with Attorney), 551.072 (Deliberations regarding Real Property), 551.073 (Deliberations regarding Gifts and Donations), 551.074 (Personnel Matters), 551.076 (Deliberations regarding Security Devices) and 551.087 (Deliberations regarding Economic Development Negotiations)."

45. Discuss the following real property matters pursuant to Texas Government Code Section 551.072:
- a. Discuss potential acquisition of real property tract(s) for the future location of the Williamson County Justice Complex
 - b. Discuss potential sale of approximately 98 acres located at Blue Springs Boulevard/Blue Ridge Drive, Georgetown, Texas.
 - c. Discuss potential sale or lease of property located at 747 County Road 138, Hutto, Texas.
46. Discuss the following pending or contemplated litigation, settlement matters and/or other confidential attorney-client legal matters pursuant to the Texas Government Code Section 551.071:
- a. Legal matters pertaining to the statutory duties and legal responsibilities of the Williamson County Fire Marshal.

REGULAR AGENDA (continued)

47. Comments from Commissioners.
48. **Public Comment Period for County Matters that are not on the Agenda.** The Commissioners Court will conduct a Public Comment Period to allow members of the public, who have properly submitted a Public Participation Form, to address the Commissioners Court regarding matters pertaining to or affecting Williamson County, but that do not appear as an Agenda Item on the Commissioners Court's Agenda. During this Public Comment Period, speakers shall be limited to a maximum of two (2) minutes to make his or her remarks and the maximum overall discussion time allowed for this Public Comment Period, regardless of the number of members of the public wishing to address the Court during such period, shall be limited to ten (10) minutes. Speaking time, to the extent possible, will be evenly allocated among speakers should more than five (5) speakers desire to speak during this Public Comment Period. Please note that the members of the Court may not comment during the meeting about matters that are not on the Commissioners Court's Agenda.

Steven Snell, County Judge

This notice of meeting was posted in the locked box located on the south side of the Williamson County Courthouse, a place readily accessible to the general public at all times, on the 4th day of March 2026 at 5:00 pm and remained posted for at least three business days before the scheduled date of the meeting.

Commissioners Court - Regular Session

3.

Meeting Date: 03/10/2026

Workers Compensation Line Item Transfer

Submitted By: Ashlie Holladay, Budget Office

Department: Budget Office

Agenda Category: Consent

Information

Agenda Item

Discuss, consider and take appropriate action on a line item transfer for various departments to cover shortfalls and enable payment of the workers' compensation invoice.

Public Background

Each year, we are given projected rates for workers' compensation charges. The rates are applied to compensation dollars and our invoice is based on claims. It is difficult to project exactly what the charges will be. Adjustments are made using surplus dollars in departmental lines first and then contingencies in the work comp line or other insurance lines, hence the reason we budget for this.

Fiscal Impact

From/To	Acct No.	Description	Amount
---------	----------	-------------	--------

Attachments

FY 26 Work Comp LIT

Form Review

Inbox

County Judge Exec Asst.

Form Started By: Ashlie Holladay

Final Approval Date: 03/03/2026

Reviewed By

Delia Colon

Date

03/03/2026 08:44 AM

Started On: 03/03/2026 08:33 AM

Fund	Dept	Object	Dept Name	FROM	TO
0100	0211	002050	COMMISSIONER PCT 1 / WORK COMP		\$ 17.98
0100	0212	002050	COMMISSIONER PCT 2 / WORK COMP		\$ 13.59
0100	0213	002050	COMMISSIONER PCT 3 / WORK COMP		\$ 21.77
0100	0214	002050	COMMISSIONER PCT 4 / WORK COMP		\$ 21.09
0100	0382	002050	DRUG COURT / WORK COMP		\$ 1,155.81
0100	0400	002050	COUNTY JUDGE / WORK COMP		\$ 14.98
0100	0401	002050	COMMISSIONERS COURT / WORK COMP		\$ 1,541.86
0100	0402	002050	HUMAN RESOURCES / WORK COMP		\$ 65.99
0100	0403	002050	COUNTY CLERK / WORK COMP		\$ 35.82
0100	0404	002050	COUNTY CLERK-JUDICIAL / WORK COMP		\$ 63.50
0100	0405	002050	VETERAN SERVICES / WORK COMP		\$ 15.45
0100	0406	002050	PUBLIC AFFAIRS / WORK COMP		\$ 26.39
0100	0407	002050	COUNTY MANAGER / WORK COMP		\$ 7,746.91
0100	0425	002050	COUNTY COURTS AT LAW / WORK COMP		\$ 2,065.57
0100	0426	002050	COUNTY COURT AT LAW 1 / WORK COMP		\$ 60.50
0100	0427	002050	COUNTY COURT AT LAW 2 / WORK COMP		\$ 61.82
0100	0428	002050	COUNTY COURT AT LAW 3 / WORK COMP		\$ 58.98
0100	0429	002050	COUNTY COURT AT LAW 4 / WORK COMP		\$ 58.07
0100	0430	002050	COUNTY COURT AT LAW 5 / WORK COMP		\$ 54.65
0100	0435	002050	DISTRICT COURTS / WORK COMP		\$ 23.55
0100	0436	002050	26TH DISTRICT COURT / WORK COMP		\$ 23.21
0100	0437	002050	277TH DISTRICT COURT / WORK COMP		\$ 24.73
0100	0438	002050	368TH DISTRICT COURT / WORK COMP		\$ 24.17
0100	0439	002050	395TH DISTRICT COURT / WORK COMP		\$ 23.78
0100	0440	002050	DISTRICT ATTORNEY / WORK COMP		\$ 1,793.18
0100	0441	002050	425TH DISTRICT COURT / WORK COMP		\$ 24.22
0100	0442	002050	480TH DISTRICT COURT / WORK COMP		\$ 22.69
0100	0450	002050	DISTRICT CLERK / WORK COMP		\$ 102.79
0100	0451	002050	J.P. PRECINCT 1 / WORK COMP		\$ 43.76
0100	0452	002050	J.P. PRECINCT 2 / WORK COMP		\$ 35.52
0100	0453	002050	J.P. PRECINCT 3 / WORK COMP		\$ 74.90
0100	0454	002050	J.P. PRECINCT 4 / WORK COMP		\$ 40.07
0100	0475	002050	COUNTY ATTORNEY / WORK COMP		\$ 1,453.62
0100	0477	002050	MAGISTRATE OFFICE / WORK COMP		\$ 40.00
0100	0491	002050	BUDGET OFFICE / WORK COMP		\$ 55.59
0100	0492	002050	ELECTIONS / WORK COMP		\$ 63.25
0100	0494	002050	PURCHASING DEPT / WORK COMP		\$ 71.95
0100	0495	002050	COUNTY AUDITOR / WORK COMP		\$ 221.57
0100	0497	002050	COUNTY TREASURER / WORK COMP		\$ 22.02
0100	0499	002050	CO TAX ASSESSOR COLLECTOR / WORK COMP		\$ 278.46
0100	0503	002050	INFORMATION TECHNOLOGY / WORK COMP		\$ 711.84
0100	0509	002050	FACILITIES MANAGEMENT / WORK COMP		\$ 1,850.88
0100	0523	002050	PUBLIC SAFETY IT / WORK COMP		\$ 46.32
0100	0540	002050	EMS / WORK COMP		\$ 142,458.71
0100	0551	002050	CONSTABLE PRECINCT 1 / WORK COMP		\$ 1,710.73
0100	0552	002050	CONSTABLE PRECINCT 2 / WORK COMP		\$ 3,382.17

0100	0553	002050	CONSTABLE PRECINCT 3 / WORK COMP	\$	3,775.92
0100	0554	002050	CONSTABLE PRECINCT 4 / WORK COMP	\$	3,873.76
0100	0560	002050	COUNTY SHERIFF / WORK COMP	\$	44,488.46
0100	0562	002050	DPS - ABC GTOWN / WORK COMP	\$	3.72
0100	0566	002050	DEATH INQUESTS / WORK COMP	\$	3,320.33
0100	0570	002050	COUNTY JAIL / WORK COMP	\$	101,725.63
0100	0581	002050	911 COMMUNICATIONS / WORK COMP	\$	862.62
0100	0583	002050	EMERGENCY SERVICES DEPARTMENT / WORK COMP	\$	90.74
0100	0587	002050	WIRELESS COMMUNICATION / WORK COMP	\$	36.57
0100	0591	002050	PRETRIAL / WORK COMP	\$	151.33
0100	0665	002050	EXTENSION SERVICE / WORK COMP	\$	129.93
0100	0841	002050	RISK ADMINISTRATION / WORK COMP	\$	34.05
0100	0409	004413	NON-DEPARTMENTAL / PERSONAL LIABILITY INS.	\$	119,470.99
0100	0409	002050	NON-DEPARTMENTAL / WORK COMP	\$	178,992.81
0100	0215	002050	INFRASTRUCTURE DEPT / WORK COMP	\$	266.07
0100	0443	002050	512TH DISTRICT COURT / WORK COMP	\$	195.61
0100	0510	002050	PARKS DEPARTMENT / WORK COMP	\$	1,239.74
0100	0541	002050	EMERGENCY MANAGEMENT / WORK COMP	\$	43.83
0100	0542	002050	FIRE MARSHAL SPEC OPS/HAZ-MAT / WORK COMP	\$	498.12
0100	0576	002050	JUVENILE SERVICES / WORK COMP	\$	25,051.00
0100	0661	002050	ON-SITE SEWAGE FACILITIES / WORK COMP	\$	459.30
0200	0210	002050	UNIFIED ROAD SYSTEM / WORK COMP	\$	10,505.18
0200	0210	004998	UNIFIED ROAD SYSTEM / CONTINGENCIES	\$	10,505.18
0408	0698	002050	DIST ATTY ASSETS FORFEITURES / WORK COMP	\$	1,253.00
0408	0698	004999	DIST ATTY ASSETS FORFEITURES / MISC.	\$	1,253.00
0546	0546	002050	ANIMAL SERVICES DONATIONS / WORK COMP	\$	1,000.23
0546	0546	003670	ANIMAL SERVICES DONATIONS / DONATIONS	\$	1,000.23

Commissioners Court - Regular Session

4.

Meeting Date: 03/10/2026

Compensation Items

Submitted By: Kayla Marek, Human Resources

Department: Human Resources

Agenda Category: Consent

Information

Agenda Item

Discuss, consider and take appropriate action on approving compensation changes, position title changes, position grade changes, and any corresponding line item transfers.

Public Background

See attached documentation for details.

Fiscal Impact

From/To	Acct No.	Description	Amount
---------	----------	-------------	--------

Attachments

Merit Report

Merit LIT

Position Changes

Form Review

Inbox

Human Resources (Originator)

County Judge Exec Asst.

Form Started By: Kayla Marek

Final Approval Date: 03/03/2026

Reviewed By

Allen Frederick

Delia Colon

Date

03/03/2026 04:40 PM

03/03/2026 04:40 PM

Started On: 03/03/2026 03:36 PM

Department	Position	Emp Num	Current Annual Salary	Merit Amt	Periodic Merit%	New Annual Salary	Lump-sum Merit	Pay Proposal Reason	Effective Date of Change
911 Communications	Call Taker.2078.001100.	15340	\$48,151.50	\$722.28	1.50	\$48,873.78	-	MERIT	13-Mar-26
Animal Services	Sr Administrative Spec.0194.001100.	17446	\$46,675.20	\$1,400.26	3.00	\$48,075.46	-	MERIT	27-Mar-26
County Clerk Archives	Deputy County Clerk.2071.001100.	17712	\$45,000.01	\$1,799.99	4.00	\$46,800.00	-	MERIT	13-Mar-26
County Clerk Judicial	Financial Specialist.0685.001100.	15093	\$57,055.27	\$3,314.33	5.81	\$60,369.61	-	MERIT	13-Mar-26

				(TO)	(FROM)
entity	fund	dept	object	dr	cr
01	0545	0545	001100	1,400.26	
01	0545	0545	001130		1,400.26
01	0384	0384	001100	1,799.99	
01	0384	0384	001130		1,799.99
01	0100	0404	001100	3,314.33	
01	0100	0404	002010	253.55	
01	0100	0404	002020	505.85	
01	0100	8002	001130		3,314.33
01	0100	8002	002010		253.55
01	0100	8002	002020		505.85
01	0100	0581	001100	722.28	
01	0100	0581	002010	55.25	
01	0100	0581	002020	110.24	
01	0100	8004	001130		722.28
01	0100	8004	002010		55.25
01	0100	8004	002020		110.24

Department Number and Name	PCN	EE ID	Current Annual Salary	*New Annual Salary	Current Position Budget Amount	*New Position Budget Amount	Reduction to Position Budget	Increase to Position Budget	Change notes	Earliest Oracle Effective Date
0210 Unified Road Systems	1603	Vacant	N/A	N/A	\$75,292.17	\$72,403.16	\$2,889.01	N/A	Reallocation of position budget to facilitate Reclasse as allowed by policy. Surplus salary from PCNs 1603, 1586, 1510, 1540, 1555, 1602, 2131, 1517, 1497 to PCN 1508	3/13/2026
0210 Unified Road Systems	1586	17791	\$48,706.26	\$48,706.26	\$50,700.49	\$48,706.26	\$1,994.23	N/A	Reallocation of position budget to facilitate Reclasse as allowed by policy. Surplus salary from PCNs 1603, 1586, 1510, 1540, 1555, 1602, 2131, 1517, 1497 to PCN 1508	3/13/2026
0210 Unified Road Systems	1510	17723	\$46,375.26	\$46,375.26	\$48,537.74	\$46,375.26	\$2,162.48	N/A	Reallocation of position budget to facilitate Reclasse as allowed by policy. Surplus salary from PCNs 1603, 1586, 1510, 1540, 1555, 1602, 2131, 1517, 1497 to PCN 1508	3/13/2026
0210 Unified Road Systems	1540	17727	\$46,375.26	\$46,375.26	\$48,512.55	\$46,375.26	\$2,137.29	N/A	Reallocation of position budget to facilitate Reclasse as allowed by policy. Surplus salary from PCNs 1603, 1586, 1510, 1540, 1555, 1602, 2131, 1517, 1497 to PCN 1508	3/13/2026
0210 Unified Road Systems	1555	17785	\$46,375.26	\$46,375.26	\$48,479.53	\$46,375.26	\$2,104.27	N/A	Reallocation of position budget to facilitate Reclasse as allowed by policy. Surplus salary from PCNs 1603, 1586, 1510, 1540, 1555, 1602, 2131, 1517, 1497 to PCN 1508	3/13/2026

Department Number and Name	PCN	EE ID	Current Annual Salary	*New Annual Salary	Current Position Budget Amount	*New Position Budget Amount	Reduction to Position Budget	Increase to Position Budget	Change notes	Earliest Oracle Effective Date
0210 Unified Road Systems	1602	Vacant	N/A	N/A	\$48,230.28	\$46,375.27	\$1,855.01	N/A	Reallocation of position budget to facilitate Reclasse as allowed by policy. Surplus salary from PCNs 1603, 1586, 1510, 1540, 1555, 1602, 2131, 1517, 1497 to PCN 1508	3/13/2026
0210 Unified Road Systems	2131	13290	\$51,164.80	\$51,164.80	\$52,233.97	\$51,164.80	\$1,069.17	N/A	Reallocation of position budget to facilitate Reclasse as allowed by policy. Surplus salary from PCNs 1603, 1586, 1510, 1540, 1555, 1602, 2131, 1517, 1497 to PCN 1508	3/13/2026
0210 Unified Road Systems	1517	17744	\$46,375.26	\$46,375.26	\$46,982.83	\$46,375.26	\$607.57	N/A	Reallocation of position budget to facilitate Reclasse as allowed by policy. Surplus salary from PCNs 1603, 1586, 1510, 1540, 1555, 1602, 2131, 1517, 1497 to PCN 1508	3/13/2026
0210 Unified Road Systems	1497	17496	\$187,703.36	\$187,703.36	\$188,001.75	\$187,820.78	\$180.97	N/A	Reallocation of position budget to facilitate Reclasse as allowed by policy. Surplus salary from PCNs 1603, 1586, 1510, 1540, 1555, 1602, 2131, 1517, 1497 to PCN 1508	3/13/2026
0210 Unified Road Systems	1508	17702	\$159,114.80	\$174,114.65	\$159,114.65	\$174,114.65	N/A	\$15,000.00	Reclasse: Title & Grade Change from Senior Engineer (B.44) to Senior Technical Engineer (B.46). Surplus salary from PCNs 1603, 1586, 1510, 1540, 1555, 1602, 2131, 1517, 1497 to PCN 1508	3/13/2026

Department Number and Name	PCN	EE ID	Current Annual Salary	*New Annual Salary	Current Position Budget Amount	*New Position Budget Amount	Reduction to Position Budget	Increase to Position Budget	Change notes	Earliest Oracle Effective Date
0494 Purchasing	1217	16833	\$65,535.86	\$65,535.86	\$68,792.41	\$65,535.86	\$3,256.55	N/A	Reallocation of position budget as allowed by policy. Surplus salary from PCN 1217 and 1213 to PCN 1216.	3/13/2026
0494 Purchasing	1213	17542	\$59,346.66	\$59,346.66	\$60,894.28	\$60,886.23	\$8.05	N/A	Reallocation of position budget as allowed by policy. Surplus salary from PCN 1217 and 1213 to PCN 1216.	3/13/2026
0494 Purchasing	1216	Vacant	N/A	N/A	\$56,082.06	\$59,346.66	N/A	\$3,264.60	Reallocation of position budget as allowed by policy. Surplus salary from PCN 1217 and 1213 to PCN 1216.	3/13/2026
0570 Corrections	0389	17645	\$56,650.00	\$60,615.50	\$84,713.30	\$62,957.19	\$21,756.11	N/A	Reallocation of position budget to facilitate internal promotion/step increase as allowed by policy. Surplus salary from PCN 0389 to PCNs 0448, 0581, 2010, 0425, 0598 and 0455.	3/13/2026
0570 Corrections	0448	17766	\$56,650.00	\$60,615.50	\$60,593.17	\$60,615.50	N/A	\$22.33	Reallocation of position budget to facilitate internal promotion/step increase as allowed by policy. Surplus salary from PCN 0389 to PCNs 0448, 0581, 2010, 0425, 0598 and 0455.	3/13/2026
0570 Corrections	0581	13193	\$100,927.58	\$101,936.86	\$100,927.58	\$101,936.86	N/A	\$1,009.28	Reallocation of position budget to facilitate internal promotion/step increase as allowed by policy. Surplus salary from PCN 0389 to PCNs 0448, 0581, 2010, 0425, 0598 and 0455.	3/13/2026

Department Number and Name	PCN	EE ID	Current Annual Salary	*New Annual Salary	Current Position Budget Amount	*New Position Budget Amount	Reduction to Position Budget	Increase to Position Budget	Change notes	Earliest Oracle Effective Date
0570 Corrections	2010	Vacant	N/A	N/A	\$83,658.34	\$87,038.14	N/A	\$3,379.80	Reallocation of position budget to facilitate internal promotion/step increase as allowed by policy. Surplus salary from PCN 0389 to PCNs 0448, 0581, 2010, 0425, 0598 and 0455.	3/13/2026
0570 Corrections	0425	Vacant	N/A	N/A	\$77,765.38	\$78,261.99	N/A	\$496.61	Reallocation of position budget to facilitate internal promotion/step increase as allowed by policy. Surplus salary from PCN 0389 to PCNs 0448, 0581, 2010, 0425, 0598 and 0455.	3/13/2026
0570 Corrections	0598	Vacant	N/A	N/A	\$72,885.66	\$88,778.90	N/A	\$15,893.24	Reallocation of position budget to facilitate internal promotion/step increase as allowed by policy. Surplus salary from PCN 0389 to PCNs 0448, 0581, 2010, 0425, 0598 and 0455.	3/13/2026
0570 Corrections	0455	Vacant	N/A	N/A	\$72,793.17	\$73,748.02	N/A	\$954.85	Reallocation of position budget to facilitate internal promotion/step increase as allowed by policy. Surplus salary from PCN 0389 to PCNs 0448, 0581, 2010, 0425, 0598 and 0455.	3/13/2026

*Amount may vary slightly due to Oracle rounding

Commissioners Court - Regular Session

5.

Meeting Date: 03/10/2026

JP1 EOM FEBRUARY 2026

Submitted For: KT Musselman

Submitted By: Misty Parker, J.P. Pct. #1

Department: J.P. Pct. #1

Agenda Category: Consent

Information

Agenda Item

Discuss, consider and take appropriate action to approve Justice of the Peace, Pct. 1, February 2026 Monthly Report in compliance with Code of Crim. Proc. § 103.005.

Public Background

Fiscal Impact

From/To	Acct No.	Description	Amount
---------	----------	-------------	--------

Attachments

JP1 EOM FEBRUARY 2026

Form Review

Inbox

County Judge Exec Asst.

Form Started By: Misty Parker

Final Approval Date: 03/02/2026

Reviewed By

Delia Colon

Date

03/02/2026 03:01 PM

Started On: 03/02/2026 02:46 PM

**IN COMPLIANCE WITH ARTICLE 103
CODE OF CRIMINAL PROCEDURE**

**THE STATE OF TEXAS
COUNTY OF WILLIAMSON**

Before me, the undersigned authority, on this day personally appeared KT Musselman, Justice of the Peace, Precinct 1, Williamson County, who, on his oath, stated that the attached report of money collected is true and correct report for the month of February 2026

DETAILED REPORT IS AVAILABLE THROUGH THE AUDITOR'S OFFICE.

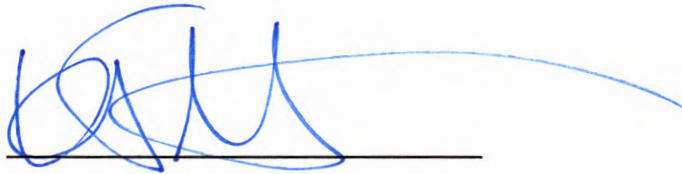

KT MUSSELMAN
JUSTICE OF THE PEACE
PRECINCT ONE

On this 2nd day of March 2026 to certify which witness my hand and seal of office.

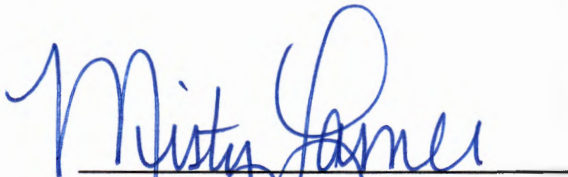

NOTARY PUBLIC
In and for the State of Texas

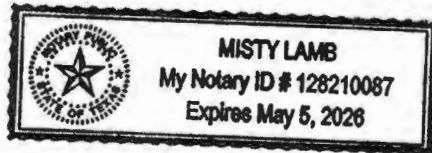

Payment Report - G/L and Fund Summary

TXWILLIAMSONPROD

Transaction Date: 2/1/2026 - 2/28/2026 Case Categories: Criminal; Civil
Locations: JP1

Payment Type: Cash Bond Deposit; Counter Payment; ...

G/L Account	G/L Account Number	Fee Totals
0100 - General Fund		
01-0100-0000-209600 - FINES DUE TO TX PARKS WILDLIFE	L-004-1-01-0100-0000-209600: 01-0100-0000-209600 - FINES DUE TO TX PARKS WILDLIFE	51.00
01-0100-0000-341200 - Sheriff Fees (WILCO)	L-004-1-01-0100-0000-341200: 01-0100-0000-341200 - Sheriff Fees (WILCO)	5.00
01-0100-0000-341801 - FEES OF OFFICE, JP PCT-1	L-004-1-01-0100-0000-341801: 01-0100-0000-341801 - FEES OF OFFICE, JP PCT #1	20,806.40
01-0100-0000-341901 - CIVIL FEES/OFFICE, CONST 1	L-004-1-01-0100-0000-341901: 01-0100-0000-341901 - Fees of Office, Const. PCT #1	28,560.00
01-0100-0000-341911 - CRIMINAL FEES/OFFICE, CONST 1	L-004-1-01-0100-0000-341911: 01-0100-0000-341911 - Fees of Office, Crim. Const PCT #1	158.86
01-0100-0000-342860 -Time Payment Fee County 2.50	L-004-1-01-0100-0000-342860: 01-0100-0000-342860 - Time Payment Fee County 2.50	247.58
01-0100-0000-351301 - FINES, JP PCT-1	L-004-1-01-0100-0000-351301: 01-0100-0000-351301 - FINES, JP PCT #1	5,156.00
01-0100-0000-365103 Language Access Fund	L-004-1-01-0100-0000-365103: Language Access Fund	1,992.00
99-9999-9999-000003 - LOCAL Consolidated CC-Misd C	L-004-1-01-99-9999-9999-000003: 99-9999-9999-000003 - LOCAL Consolidated CC-MISD C	1,212.68
0100 - General Fund Total:		58,189.52
0360 - Courthouse Security Fund		
01-0360-0000-341150 - COURTHOUSE SECURITY FEES	L-004-1-01-0360-0000-341150: 01-0360-0000-341150 - Courthouse Security Fees	3.00
0360 - Courthouse Security Fund Total:		3.00
0361 - JP Security Fund		
01-0361-0000-341151 - JP 1 SECURITY FEES	L-004-1-01-0361-0000-341151: 01-0361-0000-341151 - JP 1 SECURITY FEES	1.00
0361 - JP Security Fund Total:		1.00
0365 - Child Safety Fund		
01-0365-0000-341161 - JP CHILD SAFETY FEE	L-004-1-01-0365-0000-341161: 01-0365-0000-341161 - JP CHILD SAFETY FEE	109.28
0365 - Child Safety Fund Total:		109.28
0370 - Alternate Dispute Resolution Fund		
01-0370-0000-341170 - Alternate Dispute Resolution Fees	L-004-1-01-0370-0000-341170: 01-0370-0000-341170 - Alternate Dispute Resolution Fees	3,320.00
0370 - Alternate Dispute Resolution Fund Total:		3,320.00
0372 - Justice Court Technology Fund		
01-0372-0000-341141 - JP 1 TECHNOLOGY FEES	L-004-1-01-0372-0000-341141: 01-0372-0000-341141 - JP #1 TECHNOLOGY FEES	4.00
0372 - Justice Court Technology Fund Total:		4.00

Payment Report - G/L and Fund Summary

TXWILLIAMSONPROD

Transaction Date: 2/1/2026 - 2/28/2026 Case Categories: Criminal; Civil
 Locations: JP1

Payment Type: Cash Bond Deposit; Counter Payment; ...

G/L Account	G/L Account Number	Fee Totals
0373 - JP-1 Truancy Program Fund		
01-0373-0000-341917 - JP1 Truant Conduct (HB 2398)	L-004-1-01-0373-0000-341917: 01-0373-0000-341917 - JP1 Truant Conduct (HB 2398)	650.00
01-0373-0000-370000 - JP-1 Truancy Program Fees	L-004-1-01-0373-0000-370000: 01-0373-0000-370000 - JP-1 Truancy Program	5.00
0373 - JP-1 Truancy Program Fund Total:		655.00
0399 - State Agency Fund		
01-0399-0000-208031 - JP 1 Truancy Prev/Diversion - State	L-004-1-01-0399-0000-208031: 01-0399-0000-208031 - JP 1 Truancy Prev/Diversion - State	2.00
01-0399-0000-208160 - CCC FEES DUE TO STATE COMP	L-004-1-01-0399-0000-208160: 01-0399-0000-208160 - Consolidated Court Costs	40.00
01-0399-0000-208165 - CCC 01.2020 Fee's Due to State	L-004-1-01-0399-0000-208165: 01-0399-0000-208165 - State Con Court Cost LGC 133.102(a)(3)	5,370.54
01-0399-0000-208181 - State Consolidated Fee	L-004-0399-0000-208181: State Consolidated Fee	1,029.00
01-0399-0000-208235 - JURY SERVICE FEES DUE TO STATE	L-004-1-01-0399-0000-208235: 01-0399-0000-208235 - Jury Service Fee	4.00
01-0399-0000-208352 - CRIMINAL JUDICIAL SUPPORT DUE	L-004-1-01-0399-0000-208352: 01-0399-0000-208352 - Support of the Judiciary Fund	6.00
01-0399-0000-208400 - DPS ARREST FEES DUE TO STATE	L-004-1-01-0399-0000-208400: 01-0399-0000-208400 - Texas Highway Patrol Arrest Fees	25.92
01-0399-0000-208426 - State Traffic Fine Due To State	L-004-1-01-0399-0000-208426: 01-0399-0000-208426 - State Traffic Fine Due To State	2,340.49
01-0399-0000-208703 - INDIGENT DEF FEES - DUE TO ST	L-004-1-01-0399-0000-208703: 01-0399-0000-208703 - Indigent Defense Fee	2.00
01-0399-0000-208720 - SEATBELT FINES	L-004-1-01-0399-0000-208720: 01-0399-0000-208720 - Seatbelt Fines	43.00
0399 - State Agency Fund Total:		8,862.95
JP BOND		
01-0100-0000-207019 - JP1 Bond Liability Account	L-004-1-02-00002: JP1 Registry Bond Account Liability	88.00
JP BOND Total:		88.00
Fee Totals for All Funds:		71,232.75

Commissioners Court - Regular Session

6.

Meeting Date: 03/10/2026

Deputy Appointment Constable 1

Submitted By: Anita Lozano, Constable Pct. #1

Department: Constable Pct. #1

Agenda Category: Consent

Information

Agenda Item

Discuss, consider, and take appropriate action on the appointment of Lauren Griffith as Deputy Constable for Constable Precinct 1 pursuant to Texas Local Government Code 86.011.

Public Background

Lauren Griffith has been selected to fill the open position of Deputy Constable Precinct 1 after having completed an extensive background investigation. Prior to accepting a position at PCT 1, Griffith was a police officer with the Round Rock Independent School District (RRISD) police department. She has earned her Master Peace Officer's License. Griffith is a resident of Williamson County.

Fiscal Impact

From/To	Acct No.	Description	Amount
---------	----------	-------------	--------

Attachments

No file(s) attached.

Form Review

Inbox

County Judge Exec Asst.

Form Started By: Anita Lozano

Final Approval Date: 03/02/2026

Reviewed By

Delia Colon

Date

03/02/2026 08:49 AM

Started On: 03/02/2026 08:14 AM

Commissioners Court - Regular Session

7.

Meeting Date: 03/10/2026

2025 Constable 4 Racial Profiling Report

Submitted By: Brian Olson, Constable Pct. #4

Department: Constable Pct. #4

Agenda Category: Consent

Information

Agenda Item

Discuss, consider, and take appropriate action regarding the 2025 Racial Profiling Report for Constable 4.

Public Background

The Texas Code of Criminal Procedure requires law enforcement agencies to submit a report containing the racial profiling incident-based statistical data compiled during the previous calendar year to the Texas Commission on Law Enforcement and to the governing body served by the agency.

Fiscal Impact

From/To	Acct No.	Description	Amount
---------	----------	-------------	--------

Attachments

2025 Racial Profiling Full Report

2025 Racial Profiling Analysis Report

Form Review

Inbox

County Judge Exec Asst.

Form Started By: Brian Olson

Final Approval Date: 03/02/2026

Reviewed By

Delia Colon

Date

03/02/2026 08:48 AM

Started On: 02/28/2026 08:29 PM

Racial Profiling Report | Full

Agency Name: WILLIAMSON CO. CONST. PCT. 4
Reporting Date: 02/28/2026
TCOLE Agency Number: 491104

Chief Administrator: PAUL L LEAL

Agency Contact Information:
Phone: (512) 352-4181
Email: paul.leal@wilco.org

Mailing Address:
412 VANCE ST STE 3, TAYLOR, TX, 765743507

This Agency filed a full report

WILLIAMSON CO. CONST. PCT. 4 has adopted a detailed written policy on racial profiling. Our policy:

- 1) clearly defines acts constituting racial profiling;
- 2) strictly prohibits peace officers employed by the WILLIAMSON CO. CONST. PCT. 4 from engaging in racial profiling;
- 3) implements a process by which an individual may file a complaint with the WILLIAMSON CO. CONST. PCT. 4 if the individual believes that a peace officer employed by the WILLIAMSON CO. CONST. PCT. 4 has engaged in racial profiling with respect to the individual;
- 4) provides public education relating to the agency's complaint process;
- 5) requires appropriate corrective action to be taken against a peace officer employed by the WILLIAMSON CO. CONST. PCT. 4 who, after an investigation, is shown to have engaged in racial profiling in violation of the WILLIAMSON CO. CONST. PCT. 4 policy;
- 6) requires collection of information relating to motor vehicle stops in which a warning or citation is issued and to arrests made as a result of those stops, including information relating to:
 - a. the race or ethnicity of the individual detained;
 - b. whether a search was conducted and, if so, whether the individual detained consented to the search;
 - c. whether the peace officer knew the race or ethnicity of the individual detained before detaining that individual;
 - d. whether the peace officer used physical force that resulted in bodily injury during the stop;
 - e. the location of the stop;
 - f. the reason for the stop.
- 7) requires the chief administrator of the agency, regardless of whether the administrator is elected, employed, or appointed, to submit an annual report of the information collected under Subdivision (6) to:
 - a. the Commission on Law Enforcement; and
 - b. the governing body of each county or municipality served by the agency, if the agency is an agency of a county, municipality, or other political subdivision of the state.

The WILLIAMSON CO. CONST. PCT. 4 has satisfied the statutory data audit requirements as prescribed in Article 2.133(c), Code of Criminal Procedure during the reporting period.

Executed by: Brian Olson
Chief Deputy

Date: 02/28/2026

Total stops: 5046

Street address or approximate location of the stop

City street	533
US highway	2937
County road	1395
State highway	36
Private property or other	145

Was race or ethnicity known prior to stop?

Yes	81
No	4965

Race / Ethnicity

Alaska Native / American Indian	4
Asian / Pacific Islander	180
Black	812
White	3405
Hispanic / Latino	645

Gender

Female	1953
Alaska Native / American Indian	3
Asian / Pacific Islander	66
Black	319
White	1367
Hispanic / Latino	198
Male	3093
Alaska Native / American Indian	1
Asian / Pacific Islander	114
Black	493
White	2038
Hispanic / Latino	447

Reason for stop?

Violation of law	9
Alaska Native / American Indian	0
Asian / Pacific Islander	1
Black	2
White	4

Hispanic / Latino	2
Preexisting knowledge	4680
Alaska Native / American Indian	3
Asian / Pacific Islander	147
Black	774
White	3172
Hispanic / Latino	584
Moving traffic violation	328
Alaska Native / American Indian	1
Asian / Pacific Islander	30
Black	35
White	205
Hispanic / Latino	57
Vehicle traffic violation	29
Alaska Native / American Indian	0
Asian / Pacific Islander	2
Black	1
White	24
Hispanic / Latino	2
Was a search conducted?	
Yes	10
Alaska Native / American Indian	0
Asian / Pacific Islander	0
Black	1
White	8
Hispanic / Latino	1
No	5036
Alaska Native / American Indian	4
Asian / Pacific Islander	180
Black	811
White	3397
Hispanic / Latino	644
Reason for Search?	
Consent	0
Alaska Native / American Indian	0
Asian / Pacific Islander	0
Black	0
White	0

Hispanic / Latino	0		
Contraband	0		
Alaska Native / American Indian	0		
Asian / Pacific Islander	0		
Black	0		
White	0		
Hispanic / Latino	0		
Probable	3		
Alaska Native / American Indian	0		
Asian / Pacific Islander	0		
Black	0		
White	2		
Hispanic / Latino	1		
Inventory	0		
Alaska Native / American Indian	0		
Asian / Pacific Islander	0		
Black	0		
White	0		
Hispanic / Latino	0		
Incident to arrest	7		
Alaska Native / American Indian	0		
Asian / Pacific Islander	0		
Black	1		
White	6		
Hispanic / Latino	0		
Was Contraband discovered?			
Yes	10	Did the finding result in arrest?	
		(total should equal previous column)	
Alaska Native / American Indian	0	Yes 0	No 0
Asian / Pacific Islander	0	Yes 0	No 0
Black	1	Yes 0	No 1
White	8	Yes 2	No 6
Hispanic / Latino	1	Yes 0	No 1
No	0		
Alaska Native / American Indian	0		
Asian / Pacific Islander	0		
Black	0		
White	0		
Hispanic / Latino	0		

Description of contraband	
Drugs	4
Alaska Native / American Indian	0
Asian / Pacific Islander	0
Black	0
White	4
Hispanic / Latino	0
Weapons	0
Alaska Native / American Indian	0
Asian / Pacific Islander	0
Black	0
White	0
Hispanic / Latino	0
Currency	0
Alaska Native / American Indian	0
Asian / Pacific Islander	0
Black	0
White	0
Hispanic / Latino	0
Alcohol	0
Alaska Native / American Indian	0
Asian / Pacific Islander	0
Black	0
White	0
Hispanic / Latino	0
Stolen property	0
Alaska Native / American Indian	0
Asian / Pacific Islander	0
Black	0
White	0
Hispanic / Latino	0
Other	6
Alaska Native / American Indian	0
Asian / Pacific Islander	0
Black	1
White	4
Hispanic / Latino	1
Result of the stop	
Verbal warning	211

Alaska Native / American Indian	0
Asian / Pacific Islander	5
Black	28
White	131
Hispanic / Latino	47
Written warning	4139
Alaska Native / American Indian	4
Asian / Pacific Islander	148
Black	650
White	2868
Hispanic / Latino	469
Citation	663
Alaska Native / American Indian	0
Asian / Pacific Islander	26
Black	126
White	386
Hispanic / Latino	125
Written warning and arrest	18
Alaska Native / American Indian	0
Asian / Pacific Islander	1
Black	7
White	8
Hispanic / Latino	2
Citation and arrest	2
Alaska Native / American Indian	0
Asian / Pacific Islander	0
Black	1
White	1
Hispanic / Latino	0
Arrest	13
Alaska Native / American Indian	0
Asian / Pacific Islander	0
Black	0
White	11
Hispanic / Latino	2
Arrest based on	
Violation of Penal Code	3
Alaska Native / American Indian	0
Asian / Pacific Islander	0

Black	0
White	2
Hispanic / Latino	1
Violation of Traffic Law	10
Alaska Native / American Indian	0
Asian / Pacific Islander	1
Black	4
White	5
Hispanic / Latino	0
Violation of City Ordinance	0
Alaska Native / American Indian	0
Asian / Pacific Islander	0
Black	0
White	0
Hispanic / Latino	0
Outstanding Warrant	20
Alaska Native / American Indian	0
Asian / Pacific Islander	0
Black	4
White	13
Hispanic / Latino	3

Was physical force resulting in bodily injury used during stop?

Yes	0
Alaska Native / American Indian	0
Asian / Pacific Islander	0
Black	0
White	0
Hispanic / Latino	0
Resulting in Bodily Injury To:	
Suspect	0
Officer	0
Both	0
No	5046
Alaska Native / American Indian	4
Asian / Pacific Islander	180
Black	812
White	3405
Hispanic / Latino	645

Number of complaints of racial profiling

Total	0
Resulted in disciplinary action	0
Did not result in disciplinary action	0

Comparative Analysis

- Use TCOLE's auto generated analysis
- Use Department's submitted analysis

Optional Narrative

In Section 6.2, Pre-Existing Knowledge, the total number of stops is attributed to a selective traffic enforcement agreement with the Central Texas Regional Mobility Authority (CTRMA) to enforce tollway habitual violator laws, as authorized under the Texas Transportation Code.

Submitted electronically to the



The Texas Commission on Law Enforcement

Racial Profiling Analysis Report

WILLIAMSON CO. CONST. PCT. 4

01. Total Traffic Stops:	5046	
02. Location of Stop:		
a. City Street	533	10.56%
b. US Highway	2937	58.20%
c. County Road	1395	27.65%
d. State Highway	36	0.71%
e. Private Property or Other	145	2.87%
03. Was Race known prior to Stop:		
a. NO	4965	98.39%
b. YES	81	1.61%
04. Race or Ethnicity:		
a. Alaska/ Native American/ Indian	4	0.08%
b. Asian/ Pacific Islander	180	3.57%
c. Black	812	16.09%
d. White	3405	67.48%
e. Hispanic/ Latino	645	12.78%
05. Gender:		
a. Female	1953	38.70%
i. Alaska/ Native American/ Indian	3	0.06%
ii. Asian/ Pacific Islander	66	1.31%
iii. Black	319	6.32%
iv. White	1367	27.09%
v. Hispanic/ Latino	198	3.92%
b. Male	3093	61.30%
i. Alaska/ Native American/ Indian	1	0.02%
ii. Asian/ Pacific Islander	114	2.26%
iii. Black	493	9.77%
iv. White	2038	40.39%
v. Hispanic/ Latino	447	8.86%
06. Reason for Stop:		
a. Violation of Law	9	0.18%
i. Alaska/ Native American/ Indian	0	0.00%
ii. Asian/ Pacific Islander	1	11.11%

Racial Profiling Analysis Report

iii. Black	2	22.22%
iv. White	4	44.44%
v. Hispanic/ Latino	2	22.22%
b. Pre-Existing Knowledge	4680	92.75%
i. Alaska/ Native American/ Indian	3	0.06%
ii. Asian/ Pacific Islander	147	3.14%
iii. Black	774	16.54%
iv. White	3172	67.78%
v. Hispanic/ Latino	584	12.48%
c. Moving Traffic Violation	328	6.50%
i. Alaska/ Native American/ Indian	1	0.30%
ii. Asian/ Pacific Islander	30	9.15%
iii. Black	35	10.67%
iv. White	205	62.50%
v. Hispanic/ Latino	57	17.38%
d. Vehicle Traffic Violation	29	0.57%
i. Alaska/ Native American/ Indian	0	0.00%
ii. Asian/ Pacific Islander	2	6.90%
iii. Black	1	3.45%
iv. White	24	82.76%
v. Hispanic/ Latino	2	6.90%
07. Was a Search Conducted:		
a. NO	5036	99.80%
i. Alaska/ Native American/ Indian	4	0.08%
ii. Asian/ Pacific Islander	180	3.57%
iii. Black	811	16.10%
iv. White	3397	67.45%
v. Hispanic/ Latino	644	12.79%
b. YES	10	0.20%
i. Alaska/ Native American/ Indian	0	0.00%
ii. Asian/ Pacific Islander	0	0.00%
iii. Black	1	10.00%
iv. White	8	80.00%
v. Hispanic/ Latino	1	10.00%
08. Reason for Search:		
a. Consent	0	0.00%

Racial Profiling Analysis Report

i. Alaska/ Native American/ Indian	0	
ii. Asian/ Pacific Islander	0	
iii. Black	0	
iv. White	0	
v. Hispanic/ Latino	0	
b. Contraband in Plain View	0	0.00%
i. Alaska/ Native American/ Indian	0	
ii. Asian/ Pacific Islander	0	
iii. Black	0	
iv. White	0	
v. Hispanic/ Latino	0	
c. Probable Cause	3	0.06%
ii. Alaska/ Native American/ Indian	0	0.00%
i. Asian/ Pacific Islander	0	0.00%
iii. Black	0	0.00%
iv. White	2	66.67%
v. Hispanic/ Latino	1	33.33%
d. Inventory	0	0.00%
i. Alaska/ Native American/ Indian	0	
ii. Asian/ Pacific Islander	0	
iii. Black	0	
iv. White	0	
v. Hispanic/ Latino	0	
e. Incident to Arrest	7	0.14%
i. Alaska/ Native American/ Indian	0	0.00%
ii. Asian/ Pacific Islander	0	0.00%
iii. Black	1	14.29%
iv. White	6	85.71%
v. Hispanic/ Latino	0	0.00%
09. Was Contraband Discovered:		
YES	10	0.20%
i. Alaska/ Native American/ Indian	0	0.00%
Finding resulted in arrest - YES	0	
Finding resulted in arrest - NO	0	
ii. Asian/ Pacific Islander	0	0.00%
Finding resulted in arrest - YES	0	
Finding resulted in arrest - NO	0	
iii. Black	1	10.00%

Racial Profiling Analysis Report

Finding resulted in arrest - YES	0	
Finding resulted in arrest - NO	1	
iv. White	8	80.00%
Finding resulted in arrest - YES	2	
Finding resulted in arrest - NO	6	
v. Hispanic/ Latino	1	10.00%
Finding resulted in arrest - YES	0	
Finding resulted in arrest - NO	1	
b. NO	0	0.00%
i. Alaska/ Native American/ Indian	0	
i. Asian/ Pacific Islander	0	
iii. Black	0	
iv. White	0	
v. Hispanic/ Latino	0	
10. Description of Contraband:		
a. Drugs	4	0.08%
i. Alaska/ Native American/ Indian	0	0.00%
ii. Asian/ Pacific Islander	0	0.00%
iii. Black	0	0.00%
iv. White	4	100.00%
v. Hispanic/ Latino	0	0.00%
b. Currency	0	0.00%
i. Alaska/ Native American/ Indian	0	
ii. Asian/ Pacific Islander	0	
iii. Black	0	
iv. White	0	
v. Hispanic/ Latino	0	
c. Weapons	0	0.00%
i. Alaska/ Native American/ Indian	0	
ii. Asian/ Pacific Islander	0	
iii. Black	0	
iv. White	0	
v. Hispanic/ Latino	0	
d. Alcohol	0	0.00%
i. Alaska/ Native American/ Indian	0	
ii. Asian/ Pacific Islander	0	
iii. Black	0	
iv. White	0	

Racial Profiling Analysis Report

v. Hispanic/ Latino	0	
e. Stolen Property	0	0.00%
i. Alaska/ Native American/ Indian	0	
ii. Asian/ Pacific Islander	0	
iii. Black	0	
iv. White	0	
v. Hispanic/ Latino	0	
f. Other	6	0.12%
i. Alaska/ Native American/ Indian	0	0.00%
i. Asian/ Pacific Islander	0	0.00%
iii. Black	1	16.67%
iv. White	4	66.67%
v. Hispanic/ Latino	1	16.67%

11. Result of Stop:

a. Verbal Warning	211	4.18%
i. Alaska/ Native American/ Indian	0	0.00%
ii. Asian/ Pacific Islander	5	2.37%
iii. Black	28	13.27%
iv. White	131	62.09%
v. Hispanic/ Latino	47	22.27%
b. Written Warning	4139	82.03%
i. Alaska/ Native American/ Indian	4	0.10%
ii. Asian/ Pacific Islander	148	3.58%
iii. Black	650	15.70%
iv. White	2868	69.29%
v. Hispanic/ Latino	469	11.33%
c. Citation	663	13.14%
i. Alaska/ Native American/ Indian	0	0.00%
ii. Asian/ Pacific Islander	26	3.92%
iii. Black	126	19.00%
iv. White	386	58.22%
v. Hispanic/ Latino	125	18.85%
d. Written Warning and Arrest	18	0.36%
i. Alaska/ Native American/ Indian	0	0.00%
ii. Asian/ Pacific Islander	1	5.56%
iii. Black	7	38.89%
iv. White	8	44.44%
v. Hispanic/ Latino	2	11.11%

Racial Profiling Analysis Report

e. Citation and Arrest	2	0.04%
i. Alaska/ Native American/ Indian	0	0.00%
ii. Asian/ Pacific Islander	0	0.00%
iii. Black	1	50.00%
iv. White	1	50.00%
v. Hispanic/ Latino	0	0.00%
f. Arrest	13	0.26%
i. Alaska/ Native American/ Indian	0	0.00%
ii. Asian/ Pacific Islander	0	0.00%
iii. Black	0	0.00%
iv. White	11	84.62%
v. Hispanic/ Latino	2	15.38%
12. Arrest Based On:		
a. Violation of Penal Code	3	0.06%
i. Alaska/ Native American/ Indian	0	0.00%
ii. Asian/ Pacific Islander	0	0.00%
iii. Black	0	0.00%
iv. White	2	66.67%
v. Hispanic/ Latino	1	33.33%
b. Violation of Traffic Law	10	0.20%
i. Alaska/ Native American/ Indian	0	0.00%
ii. Asian/ Pacific Islander	1	10.00%
iii. Black	4	40.00%
iv. White	5	50.00%
v. Hispanic/ Latino	0	0.00%
c. Violation of City Ordinance	0	0.00%
i. Alaska/ Native American/ Indian	0	
ii. Asian/ Pacific Islander	0	
iii. Black	0	
iv. White	0	
v. Hispanic/ Latino	0	
d. Outstanding Warrant	20	0.40%
i. Alaska/ Native American/ Indian	0	0.00%
ii. Asian/ Pacific Islander	0	0.00%
iii. Black	4	20.00%
iv. White	13	65.00%
v. Hispanic/ Latino	3	15.00%

Racial Profiling Analysis Report

13. Was Physical Force Used:

a. NO	5046	100.00%
i. Alaska/ Native American/ Indian	4	0.08%
ii. Asian/ Pacific Islander	180	3.57%
iii. Black	812	16.09%
iv. White	3405	67.48%
v. Hispanic/ Latino	645	12.78%
b. YES	0	0.00%
i. Alaska/ Native American/ Indian	0	
ii. Asian/ Pacific Islander	0	
iii. Black	0	
iv. White	0	
v. Hispanic/ Latino	0	
b 1. YES: Physical Force Resulting in Bodily Injury to Suspect	0	
b 2. YES: Physical Force Resulting in Bodily Injury to Officer	0	
b 3. YES: Physical Force Resulting in Bodily Injury to Both	0	

14. Total Number of Racial Profiling Complaints Received: 0

REPORT DATE COMPILED 02/28/2026

Commissioners Court - Regular Session

8.

Meeting Date: 03/10/2026

Indigent/Abandoned Burial

Submitted For: Steven Snell

Submitted By: Andrea Schiele, County Judge

Department: County Judge

Agenda Category: Consent

Information

Agenda Item

Discuss, consider and take any necessary action to approve an Order for Interment by cremation of the deceased (Jerry Wayne Ritzell) who passed away in Williamson County, Texas, where the County has discretion to inter, pursuant to Tex. Health & Safety Code § 711.002(e), and authorize Beck Funeral Home to move forward with interment.

Public Background

Fiscal Impact

From/To	Acct No.	Description	Amount
---------	----------	-------------	--------

Attachments

Order for Interment

Form Review

Inbox

County Judge Exec Asst. (Originator)
Form Started By: Andrea Schiele
Final Approval Date: 03/03/2026

Reviewed By

Delia Colon

Date

03/03/2026 04:31 PM
Started On: 03/03/2026 04:07 PM

STATE OF TEXAS §
 §
COUNTY OF WILLIAMSON §

**ORDER OF COMMISSIONERS COURT
OF WILLIAMSON COUNTY, TEXAS
AUTHORIZING INTERMENT
OF DECEDENT’S REMAINS
(Jerry Wayne Ritzell)**

Pursuant to the Laws and Rules of the State of Texas, the Texas Health & Safety Code, Chapter 711, Section 711.002(e), and the common law granting the County authority to regulate the public health and safety, the Commissioners Court of Williamson County finds that:

Jerry Wayne Ritzell (SSN xxx-xx-5306) passed away on July 22, 2025, at the age of 62, at a hospice facility located in Williamson County, Texas.

The Court also finds that there has been an investigation to obtain information regarding next of kin and the ability to pay for interment expense. However, all attempts to contact any known next of kin of the deceased’s family have failed to identify any responsible or known next of kin with the ability to pay for necessary expenses. In the facts presented in this case, the deceased’s body has either become abandoned or those with the ability to pay are unable to do so.

The Court finds that this case involves either an abandoned body or is qualified for indigent burial; therefore, the duty to cover the costs of interment falls to Williamson County.

IT IS THEREFORE ORDERED THAT the deceased body shall be interred (*i.e.*, permanent disposition of remains by entombment, burial, or placement in a niche).

IT IS FURTHER ORDERED THAT costs of cremation of the deceased be paid by Williamson County, Texas in accordance with its policies and regulations and that Beck Funeral Home is granted authority to cremate the deceased.

Signed and entered this 10th day of March 2026.

Hon. Steve Snell
Williamson County Judge

Commissioners Court - Regular Session

9.

Meeting Date: 03/10/2026

CDBG 2025 Contracts (Habitat, Key2Free, Operation Liberty Hill)

Submitted By: Sally Bardwell, HUD Grants

Department: HUD Grants

Agenda Category: Consent

Information

Agenda Item

Discuss, consider and take action on Subrecipient Agreements between Williamson County and Habitat for Humanity of Williamson County, Key2Free and Operation Liberty Hill for Community Development Block Grant funding.

Public Background

The attached agreements coincide with projects outlined in the approved CDBG FY25 Annual Action Plan. This plan was approved by Commissioners Court on August 12, 2025.

Fiscal Impact

From/To	Acct No.	Description	Amount
---------	----------	-------------	--------

Attachments

- Habitat 2025 CDBG
- Key2Free 2025 CDBG
- Operation LH 2025 CDBG

Form Review

Inbox

County Judge Exec Asst.
 Form Started By: Sally Bardwell
 Final Approval Date: 03/03/2026

Reviewed By

Delia Colon

Date

03/03/2026 03:26 PM
 Started On: 03/03/2026 01:04 PM

**AGREEMENT BETWEEN WILLIAMSON COUNTY
AND HABITAT FOR HUMANITY
FOR THE USE OF COMMUNITY DEVELOPMENT BLOCK GRANT FUNDS
FISCAL YEAR 2025 FUNDING**

THIS AGREEMENT, entered into this 25th day of February, 2026, by and between Williamson County ("County"), and Habitat for Humanity ("Subrecipient");

WHEREAS, the County is the recipient of Community Development Block Grant (CDBG) funds granted by the U.S. Department of Housing and Urban Development (HUD) under Title I of the Housing and Community Development Act of 1974, as amended (42 U.S.C. 5301) and under the 1990 National Affordable Housing Act (Public Law 102-550); and

WHEREAS, the County wishes to utilize CDBG funds to assist Subrecipient in rehabilitation of approximately 40 eligible households who are in need of home repairs within CDBG participating cities or the unincorporated areas of the County. Homeowners will meet CDBG defined income qualifications. Home repairs can include, but are not limited to, roofing, siding, weatherization (windows), energy efficiency/conservation (plumbing, electrical), accessibility and/or safety; and

NOW, THEREFORE, THE PARTIES AGREE AS FOLLOWS:

PART I

1. **PURPOSE AND SCOPE OF SERVICES:**

- A. Subrecipient will perform the services described in Exhibit A attached to this Agreement pursuant to the project description, timeline and budget.
- B. Upon request, the County will provide technical assistance to the subrecipient concerning compliance with the terms of this Agreement. The subrecipient shall be responsible for all bidding procedures and subcontractual arrangements. All procedures shall be carried out in accordance with all Federal, State and local standards, and shall be monitored by the County.
- C. The Project shall be completed in compliance with all applicable state and local codes. Upon completion, this Project shall be operated in compliance with all applicable federal, state and local laws. Subrecipient agrees the funding shall be used solely for the purpose of costs as detailed in Part I.1.A. of this Agreement.

2. **TIME OF PERFORMANCE:**

Subrecipient shall perform according to the schedule described in Exhibit A. The schedule for performance is subject to change by mutual agreement of both parties in writing.

3. **PROPOSED PROJECT BUDGET**

See attached budget in Exhibit A.

4. **Objective and Outcome Statement: Sustainability for the purpose of creating suitable living environments.**

5. **Project Indicators:**

Indicators will be requested of the Subrecipient by the Williamson County Community Development Administrator and could include but is not limited to such items as amount of money leveraged; number of persons, households, businesses, unit or beds assisted, as appropriate; income levels of persons or households; race, ethnicity, and disability data. Subrecipient agrees to fulfill the Community Development Administrator's request in a reasonable time but not to extend past 15 days after request.

6. **COMPENSATION AND METHOD OF PAYMENT:**

The County shall pay and Subrecipient agrees to accept in full \$250,000 (Grant Amount – Two Hundred Fifty Thousand Dollars and no/100) (hereinafter "Grant") for performance under this Agreement, as follows:

- A. Based on the approved budget, partial payments shall be made upon presentation of (i) architect's Certificates for Payment for applicable labor and construction materials and supplies purchased or billed from the contractor for progress payments for project work completed, and/or (ii) purchase agreements, invoices, executed lien waivers, and other supporting documents covering all amounts to be paid, and/or (iii) time sheets and other source documents. Payments will be made for eligible expenses actually incurred by Subrecipient, and not to exceed actual cash requirements.
- B. All payments under this agreement are subject to receipt by the County of sufficient federal funds for the CDBG program. CDBG funds shall be drawn from the U.S. Treasury by the County through the Integrated Disbursement and Information System (IDIS). The County shall retain exclusive direct access rights to the IDIS system. All access to the IDIS system will be by duly authorized persons designated by the County as approved by HUD. Any termination, reduction or delay of receipt of CDBG funds to the County shall, at the sole option of the County, result in the termination, reduction or delay of CDBG funds to the subrecipient.
- C. Subrecipient shall not hold funds. Any funds not immediately disbursed by the subrecipient shall be returned to the County and will be deposited in the U.S. Treasury, CDBG Trust Account. Any interest earned on cash advances from the U.S. Treasury and/or County of less than one hundred dollars (\$100.00) per year may be retained by the subrecipient and used for project expenses. Any interest in

excess of one hundred dollars (\$100.00) per year shall be remitted promptly to the County.

- D. Subrecipient shall report all program income as defined at 24 CFR 570.500(a) generated by activities carried out with CDBG funds made available under this Agreement. The use of program income by Subrecipient shall comply with the requirements set forth at 24 CFR 570.504. Subrecipient may use such income during the contract period for activities permitted under this Agreement and shall reduce requests for additional funds by the amount of any such program income balances on hand. All unused program income shall be returned to the County at the end of the Agreement period. Any interest earned on cash advances from the U.S. Treasury is not program income and shall be remitted promptly to the County.

7. **TERMS AND CONDITIONS:**

- A. Subrecipient agrees to comply with all applicable federal, state, and local laws and regulations governing the funds provided under this Agreement.
- B. The County shall have no responsibility or liability for the maintenance, operation or program funding for Subrecipient.
- C. Nothing contained in this Agreement is intended to, or shall be construed in any manner, as creating or establishing the relationship of employer/employee between the parties. Subrecipient shall at all times remain independent with respect to the services to be performed under this Agreement. The County shall be exempt from payment of all unemployment compensation, FICA, retirement, life and/or medical insurance and workers' compensation insurance.
- D. During the period of this Agreement, effective as of the start of the Project, the Subrecipient and/or contractor and/or subcontractor performing any portion of the work on the Project that involves any construction trade (hereinafter collectively referred to in this provision as "Construction Trade Participant(s)") shall, at their own expense, procure and maintain all-risk property damage and liability insurance. For the term of this Agreement, Construction Trade Participant(s) shall list the County as an additional insured on said all-risk property damage and liability insurance. Property damage coverage shall not be less than the current market value of the property. Liability coverage shall include contractual insurance as well as comprehensive form insurance, and shall provide coverage of not less than \$1,000,000 bodily injury per person, \$1,000,000 bodily injury per occurrence, and \$500,000 property damage. Subrecipient, on behalf of itself and on behalf of any other Construction Trade Participant(s), shall furnish the County with a certificate of insurance before any work is started by any such party. The certificate of insurance shall include a statement guaranteeing that the insurance policy shall not be cancelled, non-renewed or materially changed without thirty (30) days advance written notice being given to the Community Development Administrator. Construction Trade Participant(s) shall provide Workers' Compensation Insurance coverage as required by Texas law for all employees involved in the performance of this Agreement. The insurance company providing the insurance must be licensed to do business in the State of Texas and rated as A or better by A.M. Best. The Subrecipient hereby acknowledges

and agrees that it shall be the responsibility of the Subrecipient to ensure that all Construction Trade Participant(s) comply with the herein stipulated minimum insurance requirements. Furthermore, the Subrecipient hereby agrees to include and require that the language of this provision be included in all contracts or subcontracts relating to the Project.

- E. Until at least the date determined in Exhibit A of this Agreement (Monitoring Period), Subrecipient shall fulfill its stated purpose in a manner satisfactory to the County as outlined in Exhibit A (Project Description and Scope of Services) of this Agreement and provide continued service. All records and public information created in connection with this Agreement or the Project shall be retained by Subrecipient until at least the date determined in Exhibit A (Monitoring Period).
- F. In the event Subrecipient discontinues its services and/or the Project funded under this Agreement prior to the date determined in Exhibit A (Monitoring Period) of this Agreement, the value of the pro-rated portion of real and personal property (tangible and intangible) secured with the CDBG funds, if applicable, under this Agreements shall revert to the County. If said property has been disposed of, then the County will be reimbursed in the amount of the current fair market value of the property less any portion of the fair market value attributable to non- County CDBG funds. (Personal property includes, but is not limited to, equipment, furnishings, and vehicles.)
- G. Except as provided herein, the terms of this Agreement shall be effective from the date of execution through and including the date determined in Exhibit A of this Agreement (Monitoring Period).

PART II

1. PERFORMANCE AND REPORTING:

- A. Subrecipient shall direct all notices, reports, insurance policies, and other communications related to or required by this Agreement to the office of the Williamson County Community Development Administrator, 710 Main Street, Ste 101 Georgetown, TX 78626. Notice by both Subrecipient and County shall be given by ordinary mail. All reports shall comply with relevant state and federal regulations, including but not limited to 2 CFR 200 – Uniform Administrative Requirements, Cost Principles, and Audit Requirements for Federal Awards.
- B. Until the completion of the Project and expenditure of all CDBG funds disbursed under this Agreement, Subrecipient shall submit monthly reports describing progress of the project activities.
- C. Not later than date determined in Exhibit A of this Agreement (Project Completion Date), Subrecipient shall provide the County with a Certified Statement of the Expenditure of Funds disbursed under this Agreement.

- D. Following completion of the Project, Subrecipient shall submit annual reports by the first day of October of each contract year until the date determined in Exhibit A (Monitoring Period) of this Agreement. The annual report shall, at a minimum, include statistics pertaining to the number, race, disability, household income, household size and place of residence of clients served at Subrecipient's Facility.
- E. No reporting requirements shall extend beyond the date determined in Exhibit A of this Agreement (Monitoring Period).

2. **OTHER REPORTS, AUDITS AND INSPECTIONS:**

- A. Subrecipient shall promptly furnish the County or HUD with such statements, records, data and information as the County or HUD may reasonably request pertaining to this Agreement.
- B. During the term of this Agreement, any time during normal business hours, Subrecipient shall make available to the County, HUD and/or the Comptroller General of the United States, or their duly authorized representatives, all of Subrecipient's records in order to permit examination of any audits, invoices, materials, payrolls, personnel records, conditions of employment, and other data relating to all matters covered by this Agreement.
- C. Subrecipient shall retain financial records, supporting documents, statistical records, and all other records pertaining to expenditures under this Agreement until the date determined in Exhibit A.

3. **ADMINISTRATIVE REQUIREMENTS AND AUDIT REQUIREMENTS:**

A. Financial Management

1. Accounting Standards

Subrecipient agrees to comply with Subpart E of 2 CFR 200 – Uniform Administrative Requirements, Cost Principles, and Audit Requirements for Federal Awards and agrees to adhere to the accounting principles and procedures required therein, utilize adequate internal controls, and maintain necessary source documentation for all costs incurred. All financial transactions and documentation must comply with the audit requirements in 2 CFR 200 – Uniform Administrative Requirements, Cost Principles, and Audit Requirements for Federal Awards. Procedures for Accounts Payable, Purchasing, and other accounting functions must meet all standards established by the Williamson County Auditor, and Subrecipient will provide any reports required by those standards.

2. Uniform Administrative Requirements

Subrecipient will comply with 24 CFR 570.502, Applicability of Uniform Administrative Requirements, Section (a), recipients and subrecipients that are governmental entities (including public agencies) and Section (b), subrecipients, except subrecipients that are governmental entities.

Subrecipients shall comply with the requirements and standards of 2 CFR 200 – Uniform Administrative Requirements, Cost Principles, and Audit Requirements for Federal Awards.

3. Audit Requirements

Subrecipient agrees to comply with the Williamson County Community Development Block Grant Audit Requirements attached as Exhibit B to this Agreement.

Subrecipients shall comply with the requirements and standards of 2 CFR 200 – Uniform Administrative Requirements, Cost Principles, and Audit Requirements for Federal Awards.

Subrecipient agrees to furnish County with a current Financial Report (financial statements) within six (6) months from the end of its fiscal year covering the period of this Agreement that includes detailed receipts and disbursement of payments to Subrecipient hereunder. **Grant funds will automatically be forfeited if the SUBRECIPIENT fails to submit a Financial Report.**

However, if Subrecipient expends One Million Dollars (\$1,000,000.00) or more in federal funds (all sources), Subrecipient must, within nine (9) months from the end of its fiscal year, supply County with a single audit and is required to submit their audit report to the Federal Audit Clearinghouse (FAC) within the earlier of 30 days after the receipt of the auditor's report, or within 9 months after the end of the audit period. **Grant funds will automatically be forfeited if the SUBRECIPIENT fails to submit an audit within the allotted time.**

If the Subrecipient expends less than One Million Dollars (\$1,000,000.00) a year in federal funds (all sources), then they are exempt from Single Audit requirement for that year; however, records must be available for review or audit by appropriate officials of the federal agency, pass-through entity and the General Accounting Office.

Subrecipient is required to submit a 990 Tax Return (Return of Organization Exempt from Income Tax) for the most recent fiscal year within six (6) months if submitting a Financial Report or within nine (9) months if submitting a Financial Audit. If the Subrecipient is not classified as an exempt entity as defined in 2 CFR 200 – Uniform Administrative Requirements, Cost Principles, and Audit Requirements for Federal Awards, the Subrecipient will not be awarded grant funds.

If applicable, Subrecipient agrees to cooperate with County relating to any inquiries regarding the Financial Audit or Financial Report and Subrecipient acknowledges that a Financial Audit or Financial Report shall be provided to County at the expense of the Subrecipient. Financial Audit or Financial Report shall be available to County staff, and any and all applicable federal agencies, and be of unrestricted access, as listed in 24 CFR Part 85.42.

4. Cost Principles

Subrecipient shall administer its program in conformance with 2 CFR 200 – Uniform Administrative Requirements, Cost Principles, and Audit Requirements for Federal Awards, as applicable, for all costs incurred whether charged on a direct or indirect basis.

B. Documentation and Record-Keeping

1. Records to Be Maintained

Subrecipient shall maintain all records that are pertinent to the activities to be funded under this Agreement, including but not limited to:

- a. Records providing a full description of each activity undertaken;
- b. Records required to document the acquisition, improvement, use or disposition of real property acquired or improved with CDBG assistance;
- c. Records documenting compliance with the fair housing and equal opportunity components of the CDBG program; and
- d. Financial records as required by 24 CFR 570.502, and 2 CFR 200 – Uniform Administrative Requirements, Cost Principles, and Audit Requirements for Federal Awards.

2. Client Data

Subrecipient shall maintain client data demonstrating client eligibility for services provided. Such data shall include, but not be limited to a signed and dated verification of income statement, or other basis for determining eligibility, and description of service provided. Such information shall be made available to County monitors or their designees for review upon request.

3. National Objectives

Subrecipient agrees to maintain documentation that demonstrates that the activities carried out with funds provided under this Agreement benefit low/moderate income persons, as defined in 24 CFR 570.208.

C. Procurement

1. Compliance

Subrecipient shall comply with current County policy concerning the purchase of equipment and shall maintain an inventory record of all non-expendable personal property as defined by such policy as may be procured with funds provided herein. All program assets (unexpended program income, property, equipment, etc.) shall

revert to the County upon termination of this Agreement. As necessary, the procurement procedures and related documents involving all purchases with grant funds are subject to review and oversight by the County's Contract Audit, Legal, and Purchasing Department.

2. OMB Standards

Subrecipient shall procure materials in accordance with the requirements of 2 CFR 200 – Uniform Administrative Requirements, Cost Principles, and Audit Requirements for Federal Awards, Procurement Standards, and shall subsequently follow, Property Management Standards, covering utilization and disposal of property. Copies of said circulars are provided and by execution of this Agreement, Subrecipient acknowledges their receipt.

D. Amendments

The County or Subrecipient may amend this Agreement at any time provided that such amendments are executed in writing and signed by a duly authorized representative of both organizations.

4. **NON-DISCRIMINATION:**

No person shall be excluded from or denied the benefits of Subrecipient's service on the basis of age, race, color, religion, creed, national origin, gender identity, sex, marital status, disability, sexual orientation or, with respect to the sale, lease, rental, use or occupancy of real property or housing accommodations, the presence or absence of dependents, familial status or public assistance source of income. All current and prospective project beneficiaries must, however, be persons in need of the programs provided by Subrecipient.

5. **SECTION 504 COMPLIANCE:**

No otherwise qualified individual with handicaps shall, solely by reason of his/her handicap, be excluded from participation in, be denied the benefits of, or be subjected to discrimination under any program or activity receiving federal financial assistance. This includes, but is not limited to, programs and/or activities related to housing, employment, and the delivery of services.

6. **EQUAL EMPLOYMENT OPPORTUNITY, FAIR HOUSING AND DRUG-FREE WORKPLACE:**

The subrecipient certifies that it is an "Equal Opportunity Employer" and that it will comply with the Texas Human Rights Commission Act, and all applicable HUD regulations pertaining to equal opportunity and affirmative action in employment. Further, the SUBRECIPIENT shall ensure that all contracts for work under this Agreement contain appropriate equal employment opportunity statements.

SUBRECIPIENT shall comply with all provisions of 24 CFR Part 100-115, which implement the Fair Housing Act. This Act prohibits discrimination in the sale or rental of housing, the financing of housing or the provision of brokerage services against any person on the basis of race, color, religion, sex, national origin, handicap or familial status.

In addition, SUBRECIPIENT certifies it will provide a drug-free workplace as defined in 24 CFR Part 24, subpart F and/or follow the requirements of 24 CFR 92.350.

7. **SECTION 3:**

Subrecipient agrees to comply with Section 3 requirements, the regulations set forth in 24 CFR 135, and to include the following language in all subcontracts executed under this Agreement:

- A. The work to be performed under this contract is subject to the requirements of Section 3 of the Housing and Urban Development Act of 1968, as amended, 12 U.S.C. 1701u (Section 3). The purpose of Section 3 is to ensure that employment and other economic opportunities generated by HUD assistance or HUD-assisted projects covered by Section 3 shall, to the greatest extent feasible, be directed to low- and very low-income persons, particularly persons who are recipients of HUD assistance for housing.
- B. The parties to this contract agree to comply with HUD's regulations in 24 CFR part 135, which implement Section 3. As evidenced by their execution of this contract, the parties to this contract certify that they are under no contractual or other impediment that would prevent them from complying with the part 135 regulations.
- C. The contractor agrees to send to each labor organization or representative of workers with which the contractor has a collective bargaining agreement or other understanding, if any, a notice advising the labor organization or workers' representative of the contractor's commitments under this Section 3 clause, and will post copies of the notice in conspicuous places at the work site where both employees and applicants for training and employment positions can see the notice. The notice shall describe the Section 3 preference, shall set forth minimum number and job titles subject to hire, availability of apprenticeship and training positions, the qualifications for each; and the name and location of the person(s) taking applications for each of the positions; and the anticipated date the work shall begin.
- D. The contractor agrees to include this Section 3 clause in every subcontract subject to compliance with regulations in 24 CFR part 135, and agrees to take appropriate actions, as provided in an applicable provision of the subcontract or in this Section 3 clause, upon a finding that the subcontractor is in violation of the regulations in 24 CFR part 135. The contractor will not subcontract with any subcontractor where the contractor has notice or knowledge that the subcontractor has been found in violation of the regulations in 24 CFR part 135.
- E. The contractor will certify that any vacant employment positions, including training positions, that are filled (1) after the contract is selected but before the contract is executed, and (2) with persons other than those to whom the regulations of 24 CFR

part 135 require employment opportunities to be directed, were not filled to circumvent the contractor's obligations under 24 CFR part 135.

- F. Noncompliance with HUD's regulations in 24 CFR part 135 may result in sanctions, termination of this contract for default, and debarment or suspension from future HUD assisted contracts.
- G. With respect to work performed in connection with Section 3 covered Indian housing assistance, section 7(b) of the Indian Self-Determination and Education Assistance Act (25 U.S.C. 450e) also applies to the work to be performed under this contract. Section 7(b) requires that to the greatest extent feasible (i) preference and opportunities for training and employment shall be given to Indians, and (ii) preference in the award of contracts and subcontracts shall be given to Indian organizations and Indian-owned Economic Enterprises. Parties to this contract that are subject to the provisions of Section 3 and section 7(b) agree to comply with Section 3 to the maximum extent feasible, but not in derogation of compliance with section 7(b).

8. **WOMEN AND MINORITY-OWNED BUSINESS ENTERPRISES:**

Subrecipient will use its best efforts to afford minority and women-owned business enterprises (at least fifty-one (51) percent owned and controlled by minority group members or women) the maximum practicable opportunity to participate in the performance of this Agreement.

9. **LABOR:**

Construction projects funded under the CDBG program in excess of \$2,000 shall comply with the labor provisions outlined in 24 CFR 570.603. Subrecipient will comply with Davis-Bacon Act (40 U.S.C. 276a-276a-5). Such contracts must also be subject to the overtime provisions, as applicable, of the Contract Work Hours and Safety Standards Act (40 U.S.C. 327-332). The Subrecipient agrees to adhere to said provisions and will not use suspended or debarred contractors.

10. **ENVIRONMENTAL ASSESSMENT AND HISTORIC PRESERVATION:**

Subrecipient shall assist the County in complying with all applicable environmental assessment and historic preservation requirements of HUD and the State Historic Preservation Officer of Texas.

11. **LEAD-BASED PAINT POISONING PREVENTION:**

Subrecipient shall comply with requirements of Section 302 of the Lead-Based Paint Poisoning Prevention Act and HUD regulations thereunder (24 CFR Part 570) insofar as they apply to the performance of this Agreement.

12. **ELIGIBILITY RESTRICTIONS FOR CERTAIN RESIDENT ALIENS (570.613):**

1. Restriction The subrecipient agrees to comply with 24 CFR 570.613, which states that certain newly legalized aliens, as described in 24 CFR part 5 subpart E are not eligible to apply for benefits under covered activities funded by the County's CDBG

programs. "Benefits" under this section means financial assistance, public services, jobs and access to new or rehabilitated housing and other facilities funded through the County's CDBG programs. "Benefits" do not include relocation services and payments to which displacees are entitled by law.

2. Covered Activities "Covered activities" under this section means activities meeting the requirements of Sec. 570.208(a) that either:

- a. Have income eligibility requirements limiting the benefits exclusively to low and moderate income persons; or
- b. Are targeted geographically or otherwise to primarily benefit low and moderate income persons (excluding activities serving the public at large, such as sewers, roads, sidewalks, and parks), and that provide benefits to persons on the basis of an application.

3. Limitation on Coverage

The restrictions under this section apply only to applicants for new benefits not being received by covered resident aliens as of the effective date of this agreement.

4. Compliance

Compliance can be accomplished by the subrecipient obtaining certification as provided in 24 CFR part 5 subpart E evidencing citizenship or eligible immigration status.

13. TERMINATION OF AGREEMENT FOR CAUSE:

If Subrecipient fails to fulfill its obligations under this Agreement in a timely and proper manner, or if Subrecipient violates any of the terms, agreements or stipulations of this Agreement, the County shall thereupon have the right to terminate this Agreement by giving written notice to Subrecipient of such termination, specifying the default or defaults, and stating that this Agreement shall be terminated 30 days after the giving of such notice unless such default or defaults are remedied within such cure period. The County shall be obligated to make no payment due hereunder after it gives said notice unless the defaults are remedied with said 30-day period. In the event of such termination, Subrecipient shall promptly repay to the County the full grant amount or that portion of the amounts that have been disbursed to Subrecipient prior to such termination.

14. TERMINATION OF AGREEMENT FOR CONVENIENCE:

This Agreement may be terminated in whole or in part upon the mutual agreement of the parties hereto, in which case the County and Subrecipient shall agree upon the termination conditions, including the effective date, the disposition of contract amounts, and in the case of partial termination, the portion to be terminated. However, if, in the case of partial termination, the County determines that the remaining portion of the award will not accomplish the purposes for which the award was made, and the award is terminated in its entirety, Subrecipient shall promptly repay to the County the full grant amount or that portion of the amount which has been disbursed to Subrecipient prior to such termination.

15. INTEREST OF CERTAIN FEDERAL AND OTHER OFFICIALS:

- A. No member or delegate to the Congress of the United States, and no resident Commissioner, shall be admitted to any share or part of this Agreement, or to any benefit to arise herefrom.
- B. No member of the governing body of the County, no officer, employee, official or agent of the County, or other local public official who exercises any functions or responsibilities in connection with the review, approval or carrying out of the Project to which this Agreement pertains, shall have any private interest, direct or indirect, in this Agreement.
- C. No federal funds appropriated under this Agreement shall be paid, by or on behalf of Subrecipient, to any person for influencing or attempting to influence a member of Congress, an officer or employee of Congress or any federal agency in connection with the awarding of any federal contract, the making of any federal grant, the making of any federal loan, the entering into of any cooperative agreement, and the extension, continuation, renewal, amendment or modification of any federal contract, grant, loan or agreement.
- D. If any funds other than federal appropriated funds have been paid or will be paid to any person for influencing or attempting to influence an officer or employee of any agency, a Member of Congress, an officer or employee of Congress, or an employee of a Member of Congress in connection with this federal agreement, Subrecipient shall complete and submit Standard Form-LLL, "Disclosure Form to Report Lobbying," in accordance with its instructions.
- E. Subrecipient shall require that the language of this certification be included in the award documents for all sub-Subrecipients and that all sub-Subrecipients shall certify and disclose accordingly.

16. **CONFLICT OF INTEREST:**

Subrecipient covenants that it has no interest and shall not acquire any interest, direct or indirect, which would conflict in any manner or degree with the performance of the services to be undertaken through this Agreement. Subrecipient further covenants that in the performance of this Agreement, no person having such an interest shall be employed by Subrecipient.

17. **GRANTOR RECOGNITION:**

All activities, facilities, and items utilized pursuant to this Agreement shall be prominently labeled as CDBG funded. In addition, Subrecipient will include a reference to the support provided herein in all publications made possible with funds made available under this Agreement.

18. **ASSIGNABILITY:**

Subrecipient shall not assign or transfer any interest in this Agreement without the prior written approval of the County. Any assignment made without such consent shall be void.

This Agreement shall be binding upon and shall inure to the benefit of the successors and assigns of the parties hereto.

19. **HOLD HARMLESS PROVISION:**

Subrecipient shall indemnify, defend and hold harmless the County, its officers, employees and agents from all liability, loss, cost, damage and expense (including reasonable attorney's fees and court costs) resulting from or incurred by reason of any actions based upon the negligent acts or omissions of Subrecipient's employees or agents during the performance of this Agreement.

20. **SEVERABILITY CLAUSE:**

If any one or more of the provisions contained in this Agreement are held to be invalid, illegal, or unenforceable, this Agreement shall be deemed severable and the remainder of the Agreement shall remain in full force and effect.

21. **LIMITATIONS OF COUNTY LIABILITY - DISCLAIMER OF RELATIONSHIP:**

The County shall not be liable to Subrecipient, or to any party, for completion of or failure to complete any improvements which are parts of the Project. Nothing contained in this Agreement, nor any act or omission of the County or Subrecipient, shall be construed to create any special duty, relationship, third-party beneficiary, respondent superior, limited or general partnership, joint venture, or any association by reason of Subrecipient's involvement with the County.

IN WITNESS WHEREOF, the Parties hereto have executed this Agreement on this _____ day of _____, 2026.

Williamson County, Texas

By: _____

Steve Snell
County Judge/Authorized Official

ACKNOWLEDGMENT

STATE OF TEXAS)
) SS:
WILLIAMSON COUNTY)

On this _____ day of _____, 2026, before me, Andrea Schiele, a Notary Public in and for said State, personally appeared Steve Snell, to me personally known, who being by me duly sworn, did say that he is the County Judge/Authorized Official of said County executing the within and foregoing instrument that the seal affixed hereto is the seal of said County, and that the said Steve Snell acknowledged the execution of said instrument to be the voluntary act and deed of said County, by it and by him voluntarily executed.

Notary Public in and for Williamson County, Texas

Habitat for Humanity (Subrecipient)

By: *Philip Golden*
Philip Golden
Executive Director

ATTEST: *Betty Jo Patterson*
Secretary

ACKNOWLEDGMENT

STATE OF TEXAS)
) SS:
WILLIAMSON COUNTY)

On this 26th day of February, 2026, before me, the undersigned, a Notary Public in and for the State of Texas, personally appeared *Philip Golden* and *Betty Jo Patterson*, to me personally known, who being by me duly sworn, did say that they are the *Executive Director* and *Secretary*, respectively, of Habitat for Humanity executing the foregoing instrument; that the seal affixed hereto is the seal of said organization; that the instrument was signed on behalf of the organization by proper authority; that *Philip Golden* and *Betty Jo Patterson* acknowledged the execution of the instrument to be the voluntary act and deed of the organization, by it and by them voluntarily executed.

Amy Jacqueline Rowan
Notary Public in and for the State of Texas



EXHIBIT A

**TO AGREEMENT BETWEEN WILLIAMSON COUNTY
AND HABITAT FOR HUMANITY
FOR THE USE OF COMMUNITY DEVELOPMENT BLOCK GRANT FUNDS
FISCAL YEAR 2025 FUNDING**

1. PROJECT DESCRIPTION AND SCOPE OF SERVICES:

A. Subrecipient to rehabilitate approximately 40 eligible households who are in need of home repairs within CDBG participating cities or the unincorporated areas of the County. Homeowners will meet CDBG defined income qualifications. Home repairs can include, but are not limited to, roofing, siding, weatherization (windows), energy efficiency/conservation (plumbing, electrical), accessibility and/or safety.

B. Upon request, the County will provide technical assistance to the subrecipient concerning compliance with the terms of this Agreement. The subrecipient shall be responsible for all bidding procedures and subcontractual arrangements. All procedures shall be carried out in accordance with all Federal, State and local standards, and shall be monitored by the County.

C. The Project shall be completed in compliance with all applicable state and local codes. Upon completion, this Project shall be operated in compliance with all applicable federal, state and local laws. Subrecipient agrees the funding shall be used solely for the purpose of costs as detailed in Part I.1.A. of this Agreement.

2. TIME OF PERFORMANCE:

Subrecipient shall perform according to the following schedule:

Program Element

- | | |
|---------------------------|--|
| 1. February-March 2026 | Award of funds and contract with Williamson County |
| 2. February-December 2026 | Program Implementation/Construction |
| 3. Monitoring Period | To be determined based on statement below |

Records are to be retained for four years from the date of submission of the County's CAPER in which the specific activity is reported for the last time, unless there is litigation,

claims, audit, negotiation, or other actions involving the records, which has started before expiration of the four year period. In such cases, the records must be retained until completion of the action and resolution of all issues which arise from it or the end of the regular four year period, whichever is longer.

3. PROPOSED PROJECT BUDGET (see attached HUD budget):

	<u>CDBG Amount</u>	<u>Subrecipient Amount</u>
A. Construction\Rehabilitation\Installation	\$250,000	_____
B. <u>Eligible equipment</u> (as outlined in 24 CFR 570.207(1))	_____	_____
C. <u>Property Acquisition</u>	_____	_____
 Total	 \$250,000	

EXHIBIT B

Williamson County Community Development Block Grant Audit Requirements

Williamson County Subrecipients will adhere to the following guidelines with regard to audit requirements:

Subrecipient agrees to comply with the applicable requirements and standards as set forth in 2 CFR 200 – Uniform Administrative Requirements, Cost Principles, and Audit Requirements for Federal Awards.

Subrecipient agrees to furnish County with a current Financial Report (financial statements) within six (6) months from the end of its fiscal year covering the period of this Agreement that includes detailed receipts and disbursement of payments to Subrecipient hereunder. Future and unused grant funds will automatically be forfeited if the Subrecipient fails to submit a Financial Report.

However, if Subrecipient expends One Million Dollars (\$1,000,000.00) or more in federal funds (all sources), Subrecipient must, within nine (9) months from the end of its fiscal year, supply County with a single audit and is required to submit their audit report to the Federal Audit Clearinghouse (FAC) within the earlier of 30 days after the receipt of the auditor's report, or within 9 months after the end of the audit period. Grant funds will automatically be forfeited if the Subrecipient fails to submit an audit within the allotted time.

If the Subrecipient expends less than One Million Dollars (\$1,000,000.00) a year in federal funds (all sources), then they are exempt from the Single Audit requirements for that year; however, records must be available for review or audit by appropriate officials of the federal agency, pass-through entity and the General Accounting Office.

If applicable, Subrecipient is required to submit a 990 Tax Return (Return of Organization Exempt from Income Tax) for the most recent fiscal year within six (6) months if submitting a Financial Report or within nine (9) months if submitting a Financial Audit. If the Subrecipient is not classified as an exempt entity as defined in 2 CFR 200 – Uniform Administrative Requirements, Cost Principles, and Audit Requirements for Federal Awards, the Subrecipient will not be awarded grant funds.

If applicable, Subrecipient agrees to cooperate with County relating to any inquiries regarding the Financial Audit or Financial Report and Subrecipient acknowledges that a Financial Audit or Financial Report shall be provided to County at the expense of the Subrecipient. Financial Audit or Financial Report shall be available to County staff, and any and all applicable federal agencies, and be of unrestricted access, in accordance with 24 CFR Part 85.42 and 24 CFR Part 84.53 as applicable.

The Williamson County CDBG office will issue letters to remind Subrecipients of the audit requirements and request timely submission. Letters will be issued on or around January 5 of each year. If no response is received, a second letter will be issued on or around February 15 of each year. If no response is received, a third request will be made approximately two weeks following. If no response is received by March 15, a final notification will be issued advising the subrecipient of suspension of reimbursement and future funding pending receipt of requested information.

Failure to follow these guidelines could result in the forfeit of future Williamson County CDBG funds and/or repayment of Williamson County CDBG funds already utilized.

Upon receipt of the required audit documents, the Williamson County Community Development Block Grant office will do an initial review to identify findings that affect the Williamson County CDBG program

or any cross-cutting findings that could affect future funding. The CDBG office will also request a review by the Williamson County Auditor's office.

In the event of a finding, Williamson County will issue a letter requesting additional information regarding the finding and the intentions of the Subrecipient to remedy the finding. Working with the Williamson County Auditor's office, the CDBG office will determine next steps to ensure that all federal, state, or local laws/statutes are met.

If a Subrecipient is unable to provide required audit documentation and has utilized CDBG funding, Williamson County will have the option to request repayment and recapture unused funds. If a Subrecipient is unable to provide required audit documentation and has not utilized CDBG funding, Williamson County will not issue funding until requirements are met or will reallocate funds to an alternate project if necessary.

EXHIBIT C Policy Requirements

If applicable:

1. The Recipient shall not use grant funds to promote "gender ideology," as defined in Executive Order (E.O.) 14168, Defending Women from Gender Ideology Extremism and Restoring Biological Truth to the Federal Government;
2. The Recipient agrees that its compliance in all respects with all applicable Federal anti-discrimination laws is material to the U.S. Government's payment decisions for purposes of section 3729(b)(4) of title 31, United States Code;
3. The Recipient certifies that it does not operate any programs that violate any applicable Federal anti-discrimination laws, including Title VI of the Civil Rights Act of 1964;
4. The Recipient shall not use any grant funds to fund or promote elective abortions, as required by E.O. 14182, Enforcing the Hyde Amendment; and that,
5. Notwithstanding anything in the NOFO or Application, this Grant shall not be governed by Executive Orders revoked by E.O. 14154, including E.O. 14008, or NOFO requirements implementing Executive Orders that have been revoked.
6. The Recipient must administer its grant in accordance with all applicable immigration restrictions and requirements, including the eligibility and verification requirements that apply under title IV of the Personal Responsibility and Work Opportunity Reconciliation Act of 1996, as amended (8 U.S.C. 1601-1646) (PRWORA) and any applicable requirements that HUD, the Attorney General, or the U.S. Citizenship and Immigration Services may establish from time to time to comply with PRWORA, Executive Order 14218, or other Executive Orders or immigration laws.
7. No state or unit of general local government that receives funding under this grant may use that funding in a manner that by design or effect facilitates the subsidization or promotion of illegal immigration or shields illegal aliens from deportation, including by maintaining policies or practices that materially impede enforcement of federal immigration statutes and regulations.
8. The Recipient must use SAVE, or an equivalent verification system approved by the Federal government, to prevent any Federal public benefit from being provided to an ineligible alien who entered the United States illegally or is otherwise unlawfully present in the United States.
9. Faith-based organizations may be subrecipients for funds on the same basis as any other organization. Recipients may not, in the selection of subrecipients, discriminate against an organization based on the organization's religious character, affiliation, or exercise.

PROGRAM-SPECIFIC REQUIREMENTS

Assistance Listing 14.218, Community Development Block Grant Program for Entitlement Communities

1. Environmental Review. The Recipient agrees to assume all the responsibilities for environmental review, decision making, and actions, as specified and required in regulations issued by the Secretary pursuant to section 104(g) of title I of the Housing and Community Development Act of 1974 and published in 24 C.F.R. part 58; except that if the Recipient is a state, the Recipient must require the unit of general local government to assume that responsibility and must comply with the state's responsibilities under 24 C.F.R. 58.4.

2. Public Use. The Recipient shall ensure that no CDBG funds are used to support any Federal, State, or local projects that seek to use the power of eminent domain, unless eminent domain is employed only for public use. For the purposes of this requirement, public use shall not be construed to include economic development that primarily benefits private entities. Any use of funds for mass transit, railroad, airport, seaport, or highway projects as well as utility projects that benefit or serve the general public (including energy-, communication-, water-, and wastewater-related infrastructure), other structures designated for use by the general public or which have other common-carrier or public-utility functions that serve the general public and are subject to regulation and oversight by the government, and projects for the removal of an immediate threat to public health and safety or brownfield as defined in the Small Business Liability Relief and Brownfields Revitalization Act (Pub. Law No. 107–118) shall be considered a public use for purposes of eminent domain.

3. Prohibition on Selling, Trading, and Transferring Funds. The Recipient or unit of general local government that directly or indirectly receives CDBG funds may not sell, trade, or otherwise transfer all or any such portion of such funds to another such entity in exchange for any other funds, credits or non-Federal considerations, but must use such funds for activities eligible under title I of the Housing and Community Development Act of 1974.

4. Construction of Water and Sewer Facilities. Notwithstanding any other provision of this agreement, the Recipient may not obligate or expend award funds to plan or construct water or sewer facilities, including any new or revised activities, until after 1) it completes the review procedures required under Executive Order 12372, Intergovernmental Review of Federal Programs, and 24 C.F.R. part 52 and 2) HUD provides written notice of the release of funds.

5. Funds for For-Profit Entities. Under 42 U.S.C. § 5305(a)(17), CDBG funds may not be provided to a for-profit entity unless such activity or project has been evaluated and selected in accordance with Appendix A to 24 C.F.R. § 570, Guidelines and Objectives for Evaluating Project Costs and Financial Requirements.

6. Violence Against Women Act. The Recipient will comply with the right to report crime and emergencies protections at 34 U.S.C. § 12495 of the Violence Against Women Act.

**AGREEMENT BETWEEN WILLIAMSON COUNTY
AND KEY2FREE
FOR THE USE OF COMMUNITY DEVELOPMENT BLOCK GRANT FUNDS
FISCAL YEAR 2025 FUNDING**

THIS AGREEMENT, entered into this 25 day of February, 2026, by and between Williamson County ("County"), and Key2FFree ("Subrecipient");

WHEREAS, the County is the recipient of Community Development Block Grant (CDBG) funds granted by the U.S. Department of Housing and Urban Development (HUD) under Title I of the Housing and Community Development Act of 1974, as amended (42 U.S.C. 5301) and under the 1990 National Affordable Housing Act (Public Law 102-550); and

WHEREAS, the County wishes to utilize CDBG funds to assist Subrecipient in providing medical, psychiatric, therapeutic, case management and rental assistance for victims of human trafficking; and

NOW, THEREFORE, THE PARTIES AGREE AS FOLLOWS:

PART I

1. **PURPOSE AND SCOPE OF SERVICES:**

- A. Subrecipient will perform the services described in Exhibit A attached to this Agreement pursuant to the project description, timeline and budget.
- B. Upon request, the County will provide technical assistance to the subrecipient concerning compliance with the terms of this Agreement. The subrecipient shall be responsible for all bidding procedures and subcontractual arrangements. All procedures shall be carried out in accordance with all Federal, State and local standards, and shall be monitored by the County.
- C. The Project shall be completed in compliance with all applicable state and local codes. Upon completion, this Project shall be operated in compliance with all applicable federal, state and local laws. Subrecipient agrees the funding shall be used solely for the purpose of costs as detailed in Part I.1.A. of this Agreement.

2. **TIME OF PERFORMANCE:**

Subrecipient shall perform according to the schedule described in Exhibit A. The schedule for performance is subject to change by mutual agreement of both parties in writing.

3. **PROPOSED PROJECT BUDGET**

See attached budget in Exhibit A.

4. **Objective and Outcome Statement: Availability/Accessibility for the purpose of creating suitable living environments.**

5. **Project Indicators:**

Indicators will be requested of the Subrecipient by the Williamson County Community Development Administrator and could include but is not limited to such items as amount of money leveraged; number of persons, households, businesses, unit or beds assisted, as appropriate; income levels of persons or households; race, ethnicity, and disability data. Subrecipient agrees to fulfill the Community Development Administrator's request in a reasonable time but not to extend past 15 days after request.

6. **COMPENSATION AND METHOD OF PAYMENT:**

The County shall pay and Subrecipient agrees to accept in full \$50,000 (Grant Amount – Fifty Thousand Dollars and no/100) (hereinafter "Grant") for performance under this Agreement, as follows:

- A. Based on the approved budget, partial payments shall be made upon presentation of (i) architect's Certificates for Payment for applicable labor and construction materials and supplies purchased or billed from the contractor for progress payments for project work completed, and/or (ii) purchase agreements, invoices, executed lien waivers, and other supporting documents covering all amounts to be paid, and/or (iii) time sheets and other source documents. Payments will be made for eligible expenses actually incurred by Subrecipient, and not to exceed actual cash requirements.
- B. All payments under this agreement are subject to receipt by the County of sufficient federal funds for the CDBG program. CDBG funds shall be drawn from the U.S. Treasury by the County through the Integrated Disbursement and Information System (IDIS). The County shall retain exclusive direct access rights to the IDIS system. All access to the IDIS system will be by duly authorized persons designated by the County as approved by HUD. Any termination, reduction or delay of receipt of CDBG funds to the County shall, at the sole option of the County, result in the termination, reduction or delay of CDBG funds to the subrecipient.
- C. Subrecipient shall not hold funds. Any funds not immediately disbursed by the subrecipient shall be returned to the County and will be deposited in the U.S. Treasury, CDBG Trust Account. Any interest earned on cash advances from the U.S. Treasury and/or County of less than one hundred dollars (\$100.00) per year may be retained by the subrecipient and used for project expenses. Any interest in

excess of one hundred dollars (\$100.00) per year shall be remitted promptly to the County.

- D. Subrecipient shall report all program income as defined at 24 CFR 570.500(a) generated by activities carried out with CDBG funds made available under this Agreement. The use of program income by Subrecipient shall comply with the requirements set forth at 24 CFR 570.504. Subrecipient may use such income during the contract period for activities permitted under this Agreement and shall reduce requests for additional funds by the amount of any such program income balances on hand. All unused program income shall be returned to the County at the end of the Agreement period. Any interest earned on cash advances from the U.S. Treasury is not program income and shall be remitted promptly to the County.

7. **TERMS AND CONDITIONS:**

- A. Subrecipient agrees to comply with all applicable federal, state, and local laws and regulations governing the funds provided under this Agreement.
- B. The County shall have no responsibility or liability for the maintenance, operation or program funding for Subrecipient.
- C. Nothing contained in this Agreement is intended to, or shall be construed in any manner, as creating or establishing the relationship of employer/employee between the parties. Subrecipient shall at all times remain independent with respect to the services to be performed under this Agreement. The County shall be exempt from payment of all unemployment compensation, FICA, retirement, life and/or medical insurance and workers' compensation insurance.
- D. During the period of this Agreement, effective as of the start of the Project, the Subrecipient and/or contractor and/or subcontractor performing any portion of the work on the Project that involves any construction trade (hereinafter collectively referred to in this provision as "Construction Trade Participant(s)") shall, at their own expense, procure and maintain all-risk property damage and liability insurance. For the term of this Agreement, Construction Trade Participant(s) shall list the County as an additional insured on said all-risk property damage and liability insurance. Property damage coverage shall not be less than the current market value of the property. Liability coverage shall include contractual insurance as well as comprehensive form insurance, and shall provide coverage of not less than \$1,000,000 bodily injury per person, \$1,000,000 bodily injury per occurrence, and \$500,000 property damage. Subrecipient, on behalf of itself and on behalf of any other Construction Trade Participant(s), shall furnish the County with a certificate of insurance before any work is started by any such party. The certificate of insurance shall include a statement guaranteeing that the insurance policy shall not be cancelled, non-renewed or materially changed without thirty (30) days advance written notice being given to the Community Development Administrator. Construction Trade Participant(s) shall provide Workers' Compensation Insurance coverage as required by Texas law for all employees involved in the performance of this Agreement. The insurance company providing the insurance must be licensed to do business in the State of Texas and rated as A or better by A.M. Best. The Subrecipient hereby acknowledges

and agrees that it shall be the responsibility of the Subrecipient to ensure that all Construction Trade Participant(s) comply with the herein stipulated minimum insurance requirements. Furthermore, the Subrecipient hereby agrees to include and require that the language of this provision be included in all contracts or subcontracts relating to the Project.

- E. Until at least the date determined in Exhibit A of this Agreement (Monitoring Period), Subrecipient shall fulfill its stated purpose in a manner satisfactory to the County as outlined in Exhibit A (Project Description and Scope of Services) of this Agreement and provide continued service. All records and public information created in connection with this Agreement or the Project shall be retained by Subrecipient until at least the date determined in Exhibit A (Monitoring Period).
- F. In the event Subrecipient discontinues its services and/or the Project funded under this Agreement prior to the date determined in Exhibit A (Monitoring Period) of this Agreement, the value of the pro-rated portion of real and personal property (tangible and intangible) secured with the CDBG funds, if applicable, under this Agreements shall revert to the County. If said property has been disposed of, then the County will be reimbursed in the amount of the current fair market value of the property less any portion of the fair market value attributable to non- County CDBG funds. (Personal property includes, but is not limited to, equipment, furnishings, and vehicles.)
- G. Except as provided herein, the terms of this Agreement shall be effective from the date of execution through and including the date determined in Exhibit A of this Agreement (Monitoring Period).

PART II

1. PERFORMANCE AND REPORTING:

- A. Subrecipient shall direct all notices, reports, insurance policies, and other communications related to or required by this Agreement to the office of the Williamson County Community Development Administrator, 710 Main Street, Ste 101 Georgetown, TX 78626. Notice by both Subrecipient and County shall be given by ordinary mail. All reports shall comply with relevant state and federal regulations, including but not limited to 2 CFR 200 – Uniform Administrative Requirements, Cost Principles, and Audit Requirements for Federal Awards.
- B. Until the completion of the Project and expenditure of all CDBG funds disbursed under this Agreement, Subrecipient shall submit monthly reports describing progress of the project activities.
- C. Not later than date determined in Exhibit A of this Agreement (Project Completion Date), Subrecipient shall provide the County with a Certified Statement of the Expenditure of Funds disbursed under this Agreement.

- D. Following completion of the Project, Subrecipient shall submit annual reports by the first day of October of each contract year until the date determined in Exhibit A (Monitoring Period) of this Agreement. The annual report shall, at a minimum, include statistics pertaining to the number, race, disability, household income, household size and place of residence of clients served at Subrecipient's Facility.
- E. No reporting requirements shall extend beyond the date determined in Exhibit A of this Agreement (Monitoring Period).

2. **OTHER REPORTS, AUDITS AND INSPECTIONS:**

- A. Subrecipient shall promptly furnish the County or HUD with such statements, records, data and information as the County or HUD may reasonably request pertaining to this Agreement.
- B. During the term of this Agreement, any time during normal business hours, Subrecipient shall make available to the County, HUD and/or the Comptroller General of the United States, or their duly authorized representatives, all of Subrecipient's records in order to permit examination of any audits, invoices, materials, payrolls, personnel records, conditions of employment, and other data relating to all matters covered by this Agreement.
- C. Subrecipient shall retain financial records, supporting documents, statistical records, and all other records pertaining to expenditures under this Agreement until the date determined in Exhibit A.

3. **ADMINISTRATIVE REQUIREMENTS AND AUDIT REQUIREMENTS:**

A. Financial Management

1. Accounting Standards

Subrecipient agrees to comply with Subpart E of 2 CFR 200 – Uniform Administrative Requirements, Cost Principles, and Audit Requirements for Federal Awards and agrees to adhere to the accounting principles and procedures required therein, utilize adequate internal controls, and maintain necessary source documentation for all costs incurred. All financial transactions and documentation must comply with the audit requirements in 2 CFR 200 – Uniform Administrative Requirements, Cost Principles, and Audit Requirements for Federal Awards. Procedures for Accounts Payable, Purchasing, and other accounting functions must meet all standards established by the Williamson County Auditor, and Subrecipient will provide any reports required by those standards.

2. Uniform Administrative Requirements

Subrecipient will comply with 24 CFR 570.502, Applicability of Uniform Administrative Requirements, Section (a), recipients and subrecipients that are governmental entities (including public agencies) and Section (b), subrecipients, except subrecipients that are governmental entities.

Subrecipients shall comply with the requirements and standards of 2 CFR 200 – Uniform Administrative Requirements, Cost Principles, and Audit Requirements for Federal Awards.

3. Audit Requirements

Subrecipient agrees to comply with the Williamson County Community Development Block Grant Audit Requirements attached as Exhibit B to this Agreement.

Subrecipients shall comply with the requirements and standards of 2 CFR 200 – Uniform Administrative Requirements, Cost Principles, and Audit Requirements for Federal Awards.

Subrecipient agrees to furnish County with a current Financial Report (financial statements) within six (6) months from the end of its fiscal year covering the period of this Agreement that includes detailed receipts and disbursement of payments to Subrecipient hereunder. **Grant funds will automatically be forfeited if the SUBRECIPIENT fails to submit a Financial Report.**

However, if Subrecipient expends One Million Dollars (\$1,000,000.00) or more in federal funds (all sources), Subrecipient must, within nine (9) months from the end of its fiscal year, supply County with a single audit and is required to submit their audit report to the Federal Audit Clearinghouse (FAC) within the earlier of 30 days after the receipt of the auditor's report, or within 9 months after the end of the audit period. **Grant funds will automatically be forfeited if the SUBRECIPIENT fails to submit an audit within the allotted time.**

If the Subrecipient expends less than One Million Dollars (\$1,000,000.00) a year in federal funds (all sources), then they are exempt from Single Audit requirement for that year; however, records must be available for review or audit by appropriate officials of the federal agency, pass-through entity and the General Accounting Office.

Subrecipient is required to submit a 990 Tax Return (Return of Organization Exempt from Income Tax) for the most recent fiscal year within six (6) months if submitting a Financial Report or within nine (9) months if submitting a Financial Audit. If the Subrecipient is not classified as an exempt entity as defined in 2 CFR 200 – Uniform Administrative Requirements, Cost Principles, and Audit Requirements for Federal Awards, the Subrecipient will not be awarded grant funds.

If applicable, Subrecipient agrees to cooperate with County relating to any inquiries regarding the Financial Audit or Financial Report and Subrecipient acknowledges that a Financial Audit or Financial Report shall be provided to County at the expense of the Subrecipient. Financial Audit or Financial Report shall be available to County staff, and any and all applicable federal agencies, and be of unrestricted access, as listed in 24 CFR Part 85.42.

4. Cost Principles

Subrecipient shall administer its program in conformance with 2 CFR 200 – Uniform Administrative Requirements, Cost Principles, and Audit Requirements for Federal Awards, as applicable, for all costs incurred whether charged on a direct or indirect basis.

B. Documentation and Record-Keeping

1. Records to Be Maintained

Subrecipient shall maintain all records that are pertinent to the activities to be funded under this Agreement, including but not limited to:

- a. Records providing a full description of each activity undertaken;
- b. Records required to document the acquisition, improvement, use or disposition of real property acquired or improved with CDBG assistance;
- c. Records documenting compliance with the fair housing and equal opportunity components of the CDBG program; and
- d. Financial records as required by 24 CFR 570.502, and 2 CFR 200 – Uniform Administrative Requirements, Cost Principles, and Audit Requirements for Federal Awards.

2. Client Data

Subrecipient shall maintain client data demonstrating client eligibility for services provided. Such data shall include, but not be limited to a signed and dated verification of income statement, or other basis for determining eligibility, and description of service provided. Such information shall be made available to County monitors or their designees for review upon request.

3. National Objectives

Subrecipient agrees to maintain documentation that demonstrates that the activities carried out with funds provided under this Agreement benefit low/moderate income persons, as defined in 24 CFR 570.208.

C. Procurement

1. Compliance

Subrecipient shall comply with current County policy concerning the purchase of equipment and shall maintain an inventory record of all non-expendable personal property as defined by such policy as may be procured with funds provided herein. All program assets (unexpended program income, property, equipment, etc.) shall

revert to the County upon termination of this Agreement. As necessary, the procurement procedures and related documents involving all purchases with grant funds are subject to review and oversight by the County's Contract Audit, Legal, and Purchasing Department.

2. OMB Standards

Subrecipient shall procure materials in accordance with the requirements of 2 CFR 200 – Uniform Administrative Requirements, Cost Principles, and Audit Requirements for Federal Awards, Procurement Standards, and shall subsequently follow, Property Management Standards, covering utilization and disposal of property. Copies of said circulars are provided and by execution of this Agreement, Subrecipient acknowledges their receipt.

D. Amendments

The County or Subrecipient may amend this Agreement at any time provided that such amendments are executed in writing and signed by a duly authorized representative of both organizations.

4. NON-DISCRIMINATION:

No person shall be excluded from or denied the benefits of Subrecipient's service on the basis of age, race, color, religion, creed, national origin, gender identity, sex, marital status, disability, sexual orientation or, with respect to the sale, lease, rental, use or occupancy of real property or housing accommodations, the presence or absence of dependents, familial status or public assistance source of income. All current and prospective project beneficiaries must, however, be persons in need of the programs provided by Subrecipient.

5. SECTION 504 COMPLIANCE:

No otherwise qualified individual with handicaps shall, solely by reason of his/her handicap, be excluded from participation in, be denied the benefits of, or be subjected to discrimination under any program or activity receiving federal financial assistance. This includes, but is not limited to, programs and/or activities related to housing, employment, and the delivery of services.

6. EQUAL EMPLOYMENT OPPORTUNITY, FAIR HOUSING AND DRUG-FREE WORKPLACE:

The subrecipient certifies that it is an "Equal Opportunity Employer" and that it will comply with the Texas Human Rights Commission Act, and all applicable HUD regulations pertaining to equal opportunity and affirmative action in employment. Further, the SUBRECIPIENT shall ensure that all contracts for work under this Agreement contain appropriate equal employment opportunity statements.

SUBRECIPIENT shall comply with all provisions of 24 CFR Part 100-115, which implement the Fair Housing Act. This Act prohibits discrimination in the sale or rental of housing, the financing of housing or the provision of brokerage services against any person on the basis of race, color, religion, sex, national origin, handicap or familial status.

In addition, SUBRECIPIENT certifies it will provide a drug-free workplace as defined in 24 CFR Part 24, subpart F and/or follow the requirements of 24 CFR 92.350.

7. SECTION 3:

Subrecipient agrees to comply with Section 3 requirements, the regulations set forth in 24 CFR 135, and to include the following language in all subcontracts executed under this Agreement:

- A. The work to be performed under this contract is subject to the requirements of Section 3 of the Housing and Urban Development Act of 1968, as amended, 12 U.S.C. 1701u (Section 3). The purpose of Section 3 is to ensure that employment and other economic opportunities generated by HUD assistance or HUD-assisted projects covered by Section 3 shall, to the greatest extent feasible, be directed to low- and very low-income persons, particularly persons who are recipients of HUD assistance for housing.
- B. The parties to this contract agree to comply with HUD's regulations in 24 CFR part 135, which implement Section 3. As evidenced by their execution of this contract, the parties to this contract certify that they are under no contractual or other impediment that would prevent them from complying with the part 135 regulations.
- C. The contractor agrees to send to each labor organization or representative of workers with which the contractor has a collective bargaining agreement or other understanding, if any, a notice advising the labor organization or workers' representative of the contractor's commitments under this Section 3 clause, and will post copies of the notice in conspicuous places at the work site where both employees and applicants for training and employment positions can see the notice. The notice shall describe the Section 3 preference, shall set forth minimum number and job titles subject to hire, availability of apprenticeship and training positions, the qualifications for each; and the name and location of the person(s) taking applications for each of the positions; and the anticipated date the work shall begin.
- D. The contractor agrees to include this Section 3 clause in every subcontract subject to compliance with regulations in 24 CFR part 135, and agrees to take appropriate actions, as provided in an applicable provision of the subcontract or in this Section 3 clause, upon a finding that the subcontractor is in violation of the regulations in 24 CFR part 135. The contractor will not subcontract with any subcontractor where the contractor has notice or knowledge that the subcontractor has been found in violation of the regulations in 24 CFR part 135.
- E. The contractor will certify that any vacant employment positions, including training positions, that are filled (1) after the contract is selected but before the contract is executed, and (2) with persons other than those to whom the regulations of 24 CFR

part 135 require employment opportunities to be directed, were not filled to circumvent the contractor's obligations under 24 CFR part 135.

F. Noncompliance with HUD's regulations in 24 CFR part 135 may result in sanctions, termination of this contract for default, and debarment or suspension from future HUD assisted contracts.

G. With respect to work performed in connection with Section 3 covered Indian housing assistance, section 7(b) of the Indian Self-Determination and Education Assistance Act (25 U.S.C. 450e) also applies to the work to be performed under this contract. Section 7(b) requires that to the greatest extent feasible (i) preference and opportunities for training and employment shall be given to Indians, and (ii) preference in the award of contracts and subcontracts shall be given to Indian organizations and Indian-owned Economic Enterprises. Parties to this contract that are subject to the provisions of Section 3 and section 7(b) agree to comply with Section 3 to the maximum extent feasible, but not in derogation of compliance with section 7(b).

8. **WOMEN AND MINORITY-OWNED BUSINESS ENTERPRISES:**

Subrecipient will use its best efforts to afford minority and women-owned business enterprises (at least fifty-one (51) percent owned and controlled by minority group members or women) the maximum practicable opportunity to participate in the performance of this Agreement.

9. **LABOR:**

Construction projects funded under the CDBG program in excess of \$2,000 shall comply with the labor provisions outlined in 24 CFR 570.603. Subrecipient will comply with Davis-Bacon Act (40 U.S.C. 276a-276a-5). Such contracts must also be subject to the overtime provisions, as applicable, of the Contract Work Hours and Safety Standards Act (40 U.S.C. 327-332). The Subrecipient agrees to adhere to said provisions and will not use suspended or debarred contractors.

10. **ENVIRONMENTAL ASSESSMENT AND HISTORIC PRESERVATION:**

Subrecipient shall assist the County in complying with all applicable environmental assessment and historic preservation requirements of HUD and the State Historic Preservation Officer of Texas.

11. **LEAD-BASED PAINT POISONING PREVENTION:**

Subrecipient shall comply with requirements of Section 302 of the Lead-Based Paint Poisoning Prevention Act and HUD regulations thereunder (24 CFR Part 570) insofar as they apply to the performance of this Agreement.

12. **ELIGIBILITY RESTRICTIONS FOR CERTAIN RESIDENT ALIENS (570.613):**

1. Restriction The subrecipient agrees to comply with 24 CFR 570.613, which states that certain newly legalized aliens, as described in 24 CFR part 5 subpart E are not eligible to apply for benefits under covered activities funded by the County's CDBG

programs. "Benefits" under this section means financial assistance, public services, jobs and access to new or rehabilitated housing and other facilities funded through the County's CDBG programs. "Benefits" do not include relocation services and payments to which displacees are entitled by law.

2. Covered Activities "Covered activities" under this section means activities meeting the requirements of Sec. 570.208(a) that either:

- a. Have income eligibility requirements limiting the benefits exclusively to low and moderate income persons; or
- b. Are targeted geographically or otherwise to primarily benefit low and moderate income persons (excluding activities serving the public at large, such as sewers, roads, sidewalks, and parks), and that provide benefits to persons on the basis of an application.

3. Limitation on Coverage

The restrictions under this section apply only to applicants for new benefits not being received by covered resident aliens as of the effective date of this agreement.

4. Compliance

Compliance can be accomplished by the subrecipient obtaining certification as provided in 24 CFR part 5 subpart E evidencing citizenship or eligible immigration status.

13. TERMINATION OF AGREEMENT FOR CAUSE:

If Subrecipient fails to fulfill its obligations under this Agreement in a timely and proper manner, or if Subrecipient violates any of the terms, agreements or stipulations of this Agreement, the County shall thereupon have the right to terminate this Agreement by giving written notice to Subrecipient of such termination, specifying the default or defaults, and stating that this Agreement shall be terminated 30 days after the giving of such notice unless such default or defaults are remedied within such cure period. The County shall be obligated to make no payment due hereunder after it gives said notice unless the defaults are remedied with said 30-day period. In the event of such termination, Subrecipient shall promptly repay to the County the full grant amount or that portion of the amounts that have been disbursed to Subrecipient prior to such termination.

14. TERMINATION OF AGREEMENT FOR CONVENIENCE:

This Agreement may be terminated in whole or in part upon the mutual agreement of the parties hereto, in which case the County and Subrecipient shall agree upon the termination conditions, including the effective date, the disposition of contract amounts, and in the case of partial termination, the portion to be terminated. However, if, in the case of partial termination, the County determines that the remaining portion of the award will not accomplish the purposes for which the award was made, and the award is terminated in its entirety, Subrecipient shall promptly repay to the County the full grant amount or that portion of the amount which has been disbursed to Subrecipient prior to such termination.

15. INTEREST OF CERTAIN FEDERAL AND OTHER OFFICIALS:

- A. No member or delegate to the Congress of the United States, and no resident Commissioner, shall be admitted to any share or part of this Agreement, or to any benefit to arise herefrom.
- B. No member of the governing body of the County, no officer, employee, official or agent of the County, or other local public official who exercises any functions or responsibilities in connection with the review, approval or carrying out of the Project to which this Agreement pertains, shall have any private interest, direct or indirect, in this Agreement.
- C. No federal funds appropriated under this Agreement shall be paid, by or on behalf of Subrecipient, to any person for influencing or attempting to influence a member of Congress, an officer or employee of Congress or any federal agency in connection with the awarding of any federal contract, the making of any federal grant, the making of any federal loan, the entering into of any cooperative agreement, and the extension, continuation, renewal, amendment or modification of any federal contract, grant, loan or agreement.
- D. If any funds other than federal appropriated funds have been paid or will be paid to any person for influencing or attempting to influence an officer or employee of any agency, a Member of Congress, an officer or employee of Congress, or an employee of a Member of Congress in connection with this federal agreement, Subrecipient shall complete and submit Standard Form-LLL, "Disclosure Form to Report Lobbying," in accordance with its instructions.
- E. Subrecipient shall require that the language of this certification be included in the award documents for all sub-Subrecipients and that all sub-Subrecipients shall certify and disclose accordingly.

16. **CONFLICT OF INTEREST:**

Subrecipient covenants that it has no interest and shall not acquire any interest, direct or indirect, which would conflict in any manner or degree with the performance of the services to be undertaken through this Agreement. Subrecipient further covenants that in the performance of this Agreement, no person having such an interest shall be employed by Subrecipient.

17. **GRANTOR RECOGNITION:**

All activities, facilities, and items utilized pursuant to this Agreement shall be prominently labeled as CDBG funded. In addition, Subrecipient will include a reference to the support provided herein in all publications made possible with funds made available under this Agreement.

18. **ASSIGNABILITY:**

Subrecipient shall not assign or transfer any interest in this Agreement without the prior written approval of the County. Any assignment made without such consent shall be void.

This Agreement shall be binding upon and shall inure to the benefit of the successors and assigns of the parties hereto.

19. **HOLD HARMLESS PROVISION:**

Subrecipient shall indemnify, defend and hold harmless the County, its officers, employees and agents from all liability, loss, cost, damage and expense (including reasonable attorney's fees and court costs) resulting from or incurred by reason of any actions based upon the negligent acts or omissions of Subrecipient's employees or agents during the performance of this Agreement.

20. **SEVERABILITY CLAUSE:**

If any one or more of the provisions contained in this Agreement are held to be invalid, illegal, or unenforceable, this Agreement shall be deemed severable and the remainder of the Agreement shall remain in full force and effect.

21. **LIMITATIONS OF COUNTY LIABILITY - DISCLAIMER OF RELATIONSHIP:**

The County shall not be liable to Subrecipient, or to any party, for completion of or failure to complete any improvements which are parts of the Project. Nothing contained in this Agreement, nor any act or omission of the County or Subrecipient, shall be construed to create any special duty, relationship, third-party beneficiary, respondent superior, limited or general partnership, joint venture, or any association by reason of Subrecipient's involvement with the County.

IN WITNESS WHEREOF, the Parties hereto have executed this Agreement on this 25
day of February, 2026.

Williamson County, Texas

By: _____

Steve Snell
County Judge/Authorized Official

ACKNOWLEDGMENT

STATE OF TEXAS)
) SS:
WILLIAMSON COUNTY)

On this _____ day of _____, 2026, before me, Andrea Schiele, a Notary Public in and for said State, personally appeared Steve Snell, to me personally known, who being by me duly sworn, did say that he is the County Judge/Authorized Official of said County executing the within and foregoing instrument that the seal affixed hereto is the seal of said County, and that the said Steve Snell acknowledged the execution of said instrument to be the voluntary act and deed of said County, by it and by him voluntarily executed.

Notary Public in and for Williamson County, Texas

EXHIBIT A

**TO AGREEMENT BETWEEN WILLIAMSON COUNTY
AND KEY2FREE
FOR THE USE OF COMMUNITY DEVELOPMENT BLOCK GRANT FUNDS
FISCAL YEAR 2025 FUNDING**

1. PROJECT DESCRIPTION AND SCOPE OF SERVICES:

A. Subrecipient to provide medical, psychiatric, therapeutic, case management and rental assistance for victims of human trafficking.

B. Upon request, the County will provide technical assistance to the subrecipient concerning compliance with the terms of this Agreement. The subrecipient shall be responsible for all bidding procedures and subcontractual arrangements. All procedures shall be carried out in accordance with all Federal, State and local standards, and shall be monitored by the County.

C. The Project shall be completed in compliance with all applicable state and local codes. Upon completion, this Project shall be operated in compliance with all applicable federal, state and local laws. Subrecipient agrees the funding shall be used solely for the purpose of costs as detailed in Part I.1.A. of this Agreement.

2. TIME OF PERFORMANCE:

Subrecipient shall perform according to the following schedule:

Program Element

- | | |
|------------------------|--|
| 1. February-March 2026 | Award of funds and contract with Williamson County |
| 2. March-December 2026 | Program Implementation |
| 3. Monitoring Period | To be determined based on statement below |

Records are to be retained for four years from the date of submission of the County's CAPER in which the specific activity is reported for the last time, unless there is litigation, claims, audit, negotiation, or other actions involving the records, which has started before expiration of the four year period. In such cases, the records must be retained until completion of the action and resolution of all issues which arise from it or the end of the regular four year period, whichever is longer.

3. PROPOSED PROJECT BUDGET (see attached HUD budget):

	<u>CDBG Amount</u>	<u>Subrecipient Amount</u>
A. <u>Program Implementation</u>	\$50,000	_____
B. <u>Eligible equipment</u> (as outlined in 24 CFR 570.207(1))	_____	_____
C. <u>Property Acquisition</u>	_____	_____
Total	\$50,000	

EXHIBIT B

Williamson County Community Development Block Grant Audit Requirements

Williamson County Subrecipients will adhere to the following guidelines with regard to audit requirements:

Subrecipient agrees to comply with the applicable requirements and standards as set forth in 2 CFR 200 – Uniform Administrative Requirements, Cost Principles, and Audit Requirements for Federal Awards.

Subrecipient agrees to furnish County with a current Financial Report (financial statements) within six (6) months from the end of its fiscal year covering the period of this Agreement that includes detailed receipts and disbursement of payments to Subrecipient hereunder. Future and unused grant funds will automatically be forfeited if the Subrecipient fails to submit a Financial Report.

However, if Subrecipient expends One Million Dollars (\$1,000,000.00) or more in federal funds (all sources), Subrecipient must, within nine (9) months from the end of its fiscal year, supply County with a single audit and is required to submit their audit report to the Federal Audit Clearinghouse (FAC) within the earlier of 30 days after the receipt of the auditor's report, or within 9 months after the end of the audit period. Grant funds will automatically be forfeited if the Subrecipient fails to submit an audit within the allotted time.

If the Subrecipient expends less than One Million Dollars (\$1,000,000.00) a year in federal funds (all sources), then they are exempt from the Single Audit requirements for that year; however, records must be available for review or audit by appropriate officials of the federal agency, pass-through entity and the General Accounting Office.

If applicable, Subrecipient is required to submit a 990 Tax Return (Return of Organization Exempt from Income Tax) for the most recent fiscal year within six (6) months if submitting a Financial Report or within nine (9) months if submitting a Financial Audit. If the Subrecipient is not classified as an exempt entity as defined in 2 CFR 200 – Uniform Administrative Requirements, Cost Principles, and Audit Requirements for Federal Awards, the Subrecipient will not be awarded grant funds.

If applicable, Subrecipient agrees to cooperate with County relating to any inquiries regarding the Financial Audit or Financial Report and Subrecipient acknowledges that a Financial Audit or Financial Report shall be provided to County at the expense of the Subrecipient. Financial Audit or Financial Report shall be available to County staff, and any and all applicable federal agencies, and be of unrestricted access, in accordance with 24 CFR Part 85.42 and 24 CFR Part 84.53 as applicable.

The Williamson County CDBG office will issue letters to remind Subrecipients of the audit requirements and request timely submission. Letters will be issued on or around January 5 of each year. If no response is received, a second letter will be issued on or around February 15 of each year. If no response is received, a third request will be made approximately two weeks following. If no response is received by March 15, a final notification will be issued advising the subrecipient of suspension of reimbursement and future funding pending receipt of requested information.

Failure to follow these guidelines could result in the forfeit of future Williamson County CDBG funds and/or repayment of Williamson County CDBG funds already utilized.

Upon receipt of the required audit documents, the Williamson County Community Development Block Grant office will do an initial review to identify findings that affect the Williamson County CDBG program

or any cross-cutting findings that could affect future funding. The CDBG office will also request a review by the Williamson County Auditor's office.

In the event of a finding, Williamson County will issue a letter requesting additional information regarding the finding and the intentions of the Subrecipient to remedy the finding. Working with the Williamson County Auditor's office, the CDBG office will determine next steps to ensure that all federal, state, or local laws/statutes are met.

If a Subrecipient is unable to provide required audit documentation and has utilized CDBG funding, Williamson County will have the option to request repayment and recapture unused funds. If a Subrecipient is unable to provide required audit documentation and has not utilized CDBG funding, Williamson County will not issue funding until requirements are met or will reallocate funds to an alternate project if necessary.

EXHIBIT C Policy Requirements

If applicable:

1. The Recipient shall not use grant funds to promote "gender ideology," as defined in Executive Order (E.O.) 14168, Defending Women from Gender Ideology Extremism and Restoring Biological Truth to the Federal Government;
2. The Recipient agrees that its compliance in all respects with all applicable Federal anti-discrimination laws is material to the U.S. Government's payment decisions for purposes of section 3729(b)(4) of title 31, United States Code;
3. The Recipient certifies that it does not operate any programs that violate any applicable Federal anti-discrimination laws, including Title VI of the Civil Rights Act of 1964;
4. The Recipient shall not use any grant funds to fund or promote elective abortions, as required by E.O. 14182, Enforcing the Hyde Amendment; and that,
5. Notwithstanding anything in the NOFO or Application, this Grant shall not be governed by Executive Orders revoked by E.O. 14154, including E.O. 14008, or NOFO requirements implementing Executive Orders that have been revoked.
6. The Recipient must administer its grant in accordance with all applicable immigration restrictions and requirements, including the eligibility and verification requirements that apply under title IV of the Personal Responsibility and Work Opportunity Reconciliation Act of 1996, as amended (8 U.S.C. 1601-1646) (PRWORA) and any applicable requirements that HUD, the Attorney General, or the U.S. Citizenship and Immigration Services may establish from time to time to comply with PRWORA, Executive Order 14218, or other Executive Orders or immigration laws.
7. No state or unit of general local government that receives funding under this grant may use that funding in a manner that by design or effect facilitates the subsidization or promotion of illegal immigration or shields illegal aliens from deportation, including by maintaining policies or practices that materially impede enforcement of federal immigration statutes and regulations.
8. The Recipient must use SAVE, or an equivalent verification system approved by the Federal government, to prevent any Federal public benefit from being provided to an ineligible alien who entered the United States illegally or is otherwise unlawfully present in the United States.
9. Faith-based organizations may be subrecipients for funds on the same basis as any other organization. Recipients may not, in the selection of subrecipients, discriminate against an organization based on the organization's religious character, affiliation, or exercise.

PROGRAM-SPECIFIC REQUIREMENTS

Assistance Listing 14.218, Community Development Block Grant Program for Entitlement Communities

1. Environmental Review. The Recipient agrees to assume all the responsibilities for environmental review, decision making, and actions, as specified and required in regulations issued by the Secretary pursuant to section 104(g) of title I of the Housing and Community Development Act of 1974 and published in 24 C.F.R. part 58; except that if the Recipient is a state, the Recipient must require the unit of general local government to assume that responsibility and must comply with the state's responsibilities under 24 C.F.R. 58.4.

2. Public Use. The Recipient shall ensure that no CDBG funds are used to support any Federal, State, or local projects that seek to use the power of eminent domain, unless eminent domain is employed only for public use. For the purposes of this requirement, public use shall not be construed to include economic development that primarily benefits private entities. Any use of funds for mass transit, railroad, airport, seaport, or highway projects as well as utility projects that benefit or serve the general public (including energy-, communication-, water-, and wastewater-related infrastructure), other structures designated for use by the general public or which have other common-carrier or public-utility functions that serve the general public and are subject to regulation and oversight by the government, and projects for the removal of an immediate threat to public health and safety or brownfield as defined in the Small Business Liability Relief and Brownfields Revitalization Act (Pub. Law No. 107-118) shall be considered a public use for purposes of eminent domain.

3. Prohibition on Selling, Trading, and Transferring Funds. The Recipient or unit of general local government that directly or indirectly receives CDBG funds may not sell, trade, or otherwise transfer all or any such portion of such funds to another such entity in exchange for any other funds, credits or non-Federal considerations, but must use such funds for activities eligible under title I of the Housing and Community Development Act of 1974.

4. Construction of Water and Sewer Facilities. Notwithstanding any other provision of this agreement, the Recipient may not obligate or expend award funds to plan or construct water or sewer facilities, including any new or revised activities, until after 1) it completes the review procedures required under Executive Order 12372, Intergovernmental Review of Federal Programs, and 24 C.F.R. part 52 and 2) HUD provides written notice of the release of funds.

5. Funds for For-Profit Entities. Under 42 U.S.C. § 5305(a)(17), CDBG funds may not be provided to a for-profit entity unless such activity or project has been evaluated and selected in accordance with Appendix A to 24 C.F.R. § 570, Guidelines and Objectives for Evaluating Project Costs and Financial Requirements.

6. Violence Against Women Act. The Recipient will comply with the right to report crime and emergencies protections at 34 U.S.C. § 12495 of the Violence Against Women Act.

**AGREEMENT BETWEEN WILLIAMSON COUNTY
AND OPERATION LIBERTY HILL
FOR THE USE OF COMMUNITY DEVELOPMENT BLOCK GRANT FUNDS
FISCAL YEAR 2025 FUNDING**

THIS AGREEMENT, entered into this ___ day of _____, 2026, by and between Williamson County ("County"), and Operation Liberty Hill ("Subrecipient");

WHEREAS, the County is the recipient of Community Development Block Grant (CDBG) funds granted by the U.S. Department of Housing and Urban Development (HUD) under Title I of the Housing and Community Development Act of 1974, as amended (42 U.S.C. 5301) and under the 1990 National Affordable Housing Act (Public Law 102-550); and

WHEREAS, the County wishes to utilize CDBG funds to assist Subrecipient in providing temporary housing in local hotels when the weather is extremely cold or extremely hot; for people living in a place not meant for human habitation; for people coming out of an emergency shelter; for people who need transitional or supportive housing for homeless persons who originally came from the streets or emergency shelters; for people who had been in any of the previous three places but is spending 30 days or less in a hospital or other institution; for people who are being evicted within a week from a private residence and they have nowhere else to go nor the resources or support to get housed; for people who are being discharged from an institution where they resided for more than 30 consecutive days and have nowhere else to go nor the resources or support to get housed; and, people fleeing a domestic violence situation with nowhere else to go nor the resources or support to get housed; and

NOW, THEREFORE, THE PARTIES AGREE AS FOLLOWS:

PART I

1. **PURPOSE AND SCOPE OF SERVICES:**

- A. Subrecipient will perform the services described in Exhibit A attached to this Agreement pursuant to the project description, timeline and budget.
- B. Upon request, the County will provide technical assistance to the subrecipient concerning compliance with the terms of this Agreement. The subrecipient shall be responsible for all bidding procedures and subcontractual arrangements. All procedures shall be carried out in accordance with all Federal, State and local standards, and shall be monitored by the County.
- C. The Project shall be completed in compliance with all applicable state and local codes. Upon completion, this Project shall be operated in compliance with all applicable federal, state and local laws. Subrecipient agrees the funding shall be used solely for the purpose of costs as detailed in Part I.1.A. of this Agreement.

2. **TIME OF PERFORMANCE:**

Subrecipient shall perform according to the schedule described in Exhibit A. The schedule for performance is subject to change by mutual agreement of both parties in writing.

3. **PROPOSED PROJECT BUDGET**

See attached budget in Exhibit A.

4. **Objective and Outcome Statement: Affordability for the purpose of providing decent affordable housing.**

5. **Project Indicators:**

Indicators will be requested of the Subrecipient by the Williamson County Community Development Administrator and could include but is not limited to such items as amount of money leveraged; number of persons, households, businesses, unit or beds assisted, as appropriate; income levels of persons or households; race, ethnicity, and disability data. Subrecipient agrees to fulfill the Community Development Administrator's request in a reasonable time but not to extend past 15 days after request.

6. **COMPENSATION AND METHOD OF PAYMENT:**

The County shall pay and Subrecipient agrees to accept in full \$20,000 (Grant Amount – Twenty Thousand Dollars and no/100) (hereinafter "Grant") for performance under this Agreement, as follows:

- A. Based on the approved budget, partial payments shall be made upon presentation of (i) architect's Certificates for Payment for applicable labor and construction materials and supplies purchased or billed from the contractor for progress payments for project work completed, and/or (ii) purchase agreements, invoices, executed lien waivers, and other supporting documents covering all amounts to be paid, and/or (iii) time sheets and other source documents. Payments will be made for eligible expenses actually incurred by Subrecipient, and not to exceed actual cash requirements. All payments under this agreement are subject to receipt by the County of sufficient federal funds for the CDBG program. CDBG funds shall be drawn from the U.S. Treasury by the County through the Integrated Disbursement and Information System (IDIS). The County shall retain exclusive direct access rights to the IDIS system. All access to the IDIS system will be by duly authorized persons designated by the County as approved by HUD. Any termination, reduction or delay of receipt of CDBG funds to the County shall, at the sole option of the County, result in the termination, reduction or delay of CDBG funds to the subrecipient.
- B. Subrecipient shall not hold funds. Any funds not immediately disbursed by the subrecipient shall be returned to the County and will be deposited in the U.S. Treasury, CDBG Trust Account. Any interest earned on cash advances from the U.S. Treasury and/or County of less than one hundred dollars (\$100.00) per year may be retained by the subrecipient and used for project expenses. Any interest in excess of one hundred dollars (\$100.00) per year shall be remitted promptly to the County.
- C. Subrecipient shall report all program income as defined at 24 CFR 570.500(a) generated by activities carried out with CDBG funds made available under this Agreement. The use of program income by Subrecipient shall comply with the

requirements set forth at 24 CFR 570.504. Subrecipient may use such income during the contract period for activities permitted under this Agreement and shall reduce requests for additional funds by the amount of any such program income balances on hand. All unused program income shall be returned to the County at the end of the Agreement period. Any interest earned on cash advances from the U.S. Treasury is not program income and shall be remitted promptly to the County.

7. **TERMS AND CONDITIONS:**

- A. Subrecipient agrees to comply with all applicable federal, state, and local laws and regulations governing the funds provided under this Agreement.
- B. The County shall have no responsibility or liability for the maintenance, operation or program funding for Subrecipient.
- C. Nothing contained in this Agreement is intended to, or shall be construed in any manner, as creating or establishing the relationship of employer/employee between the parties. Subrecipient shall at all times remain independent with respect to the services to be performed under this Agreement. The County shall be exempt from payment of all unemployment compensation, FICA, retirement, life and/or medical insurance and workers' compensation insurance.
- D. During the period of this Agreement, effective as of the start of the Project, the Subrecipient and/or contractor and/or subcontractor performing any portion of the work on the Project that involves any construction trade (hereinafter collectively referred to in this provision as "Construction Trade Participant(s)") shall, at their own expense, procure and maintain all-risk property damage and liability insurance. For the term of this Agreement, Construction Trade Participant(s) shall list the County as an additional insured on said all-risk property damage and liability insurance. Property damage coverage shall not be less than the current market value of the property. Liability coverage shall include contractual insurance as well as comprehensive form insurance, and shall provide coverage of not less than \$1,000,000 bodily injury per person, \$1,000,000 bodily injury per occurrence, and \$500,000 property damage. Subrecipient, on behalf of itself and on behalf of any other Construction Trade Participant(s), shall furnish the County with a certificate of insurance before any work is started by any such party. The certificate of insurance shall include a statement guaranteeing that the insurance policy shall not be cancelled, non-renewed or materially changed without thirty (30) days advance written notice being given to the Community Development Administrator. Construction Trade Participant(s) shall provide Workers' Compensation Insurance coverage as required by Texas law for all employees involved in the performance of this Agreement. The insurance company providing the insurance must be licensed to do business in the State of Texas and rated as A or better by A.M. Best. The Subrecipient hereby acknowledges and agrees that it shall be the responsibility of the Subrecipient to ensure that all Construction Trade Participant(s) comply with the herein stipulated minimum insurance requirements. Furthermore, the Subrecipient hereby agrees to include and require that the language of this provision be included in all contracts or subcontracts relating to the Project.

- E. Until at least the date determined in Exhibit A of this Agreement (Monitoring Period), Subrecipient shall fulfill its stated purpose in a manner satisfactory to the County as outlined in Exhibit A (Project Description and Scope of Services) of this Agreement and provide continued service. All records and public information created in connection with this Agreement or the Project shall be retained by Subrecipient until at least the date determined in Exhibit A (Monitoring Period).
- F. In the event Subrecipient discontinues its services and/or the Project funded under this Agreement prior to the date determined in Exhibit A (Monitoring Period) of this Agreement, the value of the pro-rated portion of real and personal property (tangible and intangible) secured with the CDBG funds, if applicable, under this Agreement shall revert to the County. If said property has been disposed of, then the County will be reimbursed in the amount of the current fair market value of the property less any portion of the fair market value attributable to non- County CDBG funds. (Personal property includes, but is not limited to, equipment, furnishings, and vehicles.)
- G. Except as provided herein, the terms of this Agreement shall be effective from the date of execution through and including the date determined in Exhibit A of this Agreement (Monitoring Period).

PART II

1. PERFORMANCE AND REPORTING:

- A. Subrecipient shall direct all notices, reports, insurance policies, and other communications related to or required by this Agreement to the office of the Williamson County Community Development Administrator, 710 Main Street, Ste 101 Georgetown, TX 78626. Notice by both Subrecipient and County shall be given by ordinary mail. All reports shall comply with relevant state and federal regulations, including but not limited to 2 CFR 200 – Uniform Administrative Requirements, Cost Principles, and Audit Requirements for Federal Awards.
- B. Until the completion of the Project and expenditure of all CDBG funds disbursed under this Agreement, Subrecipient shall submit monthly reports describing progress of the project activities.
- C. Not later than date determined in Exhibit A of this Agreement (Project Completion Date), Subrecipient shall provide the County with a Certified Statement of the Expenditure of Funds disbursed under this Agreement.
- D. Following completion of the Project, Subrecipient shall submit annual reports by the first day of October of each contract year until the date determined in Exhibit A (Monitoring Period) of this Agreement. The annual report shall, at a minimum, include statistics pertaining to the number, race, disability, household income, household size and place of residence of clients served at Subrecipient's Facility.

- E. No reporting requirements shall extend beyond the date determined in Exhibit A of this Agreement (Monitoring Period).

2. **OTHER REPORTS, AUDITS AND INSPECTIONS:**

- A. Subrecipient shall promptly furnish the County or HUD with such statements, records, data and information as the County or HUD may reasonably request pertaining to this Agreement.
- B. During the term of this Agreement, any time during normal business hours, Subrecipient shall make available to the County, HUD and/or the Comptroller General of the United States, or their duly authorized representatives, all of Subrecipient's records in order to permit examination of any audits, invoices, materials, payrolls, personnel records, conditions of employment, and other data relating to all matters covered by this Agreement.
- C. Subrecipient shall retain financial records, supporting documents, statistical records, and all other records pertaining to expenditures under this Agreement until the date determined in Exhibit A.

3. **ADMINISTRATIVE REQUIREMENTS AND AUDIT REQUIREMENTS:**

A. Financial Management

1. Accounting Standards

Subrecipient agrees to comply with Subpart E of 2 CFR 200 – Uniform Administrative Requirements, Cost Principles, and Audit Requirements for Federal Awards and agrees to adhere to the accounting principles and procedures required therein, utilize adequate internal controls, and maintain necessary source documentation for all costs incurred. All financial transactions and documentation must comply with the audit requirements in 2 CFR 200 – Uniform Administrative Requirements, Cost Principles, and Audit Requirements for Federal Awards. Procedures for Accounts Payable, Purchasing, and other accounting functions must meet all standards established by the Williamson County Auditor, and Subrecipient will provide any reports required by those standards.

2. Uniform Administrative Requirements

Subrecipient will comply with 24 CFR 570.502, Applicability of Uniform Administrative Requirements, Section (a), recipients and subrecipients that are governmental entities (including public agencies) and Section (b), subrecipients, except subrecipients that are governmental entities.

Subrecipients shall comply with the requirements and standards of 2 CFR 200 – Uniform Administrative Requirements, Cost Principles, and Audit Requirements for Federal Awards.

3. Audit Requirements

Subrecipient agrees to comply with the Williamson County Community Development Block Grant Audit Requirements attached as Exhibit B to this Agreement.

Subrecipients shall comply with the requirements and standards of 2 CFR 200 – Uniform Administrative Requirements, Cost Principles, and Audit Requirements for Federal Awards.

Subrecipient agrees to furnish County with a current Financial Report (financial statements) within six (6) months from the end of its fiscal year covering the period of this Agreement that includes detailed receipts and disbursement of payments to Subrecipient hereunder. **Grant funds will automatically be forfeited if the SUBRECIPIENT fails to submit a Financial Report.**

However, if Subrecipient expends One Million Dollars (\$1,000,000.00) or more in federal funds (all sources), Subrecipient must, within nine (9) months from the end of its fiscal year, supply County with a single audit and is required to submit their audit report to the Federal Audit Clearinghouse (FAC) within the earlier of 30 days after the receipt of the auditor's report, or within 9 months after the end of the audit period. **Grant funds will automatically be forfeited if the SUBRECIPIENT fails to submit an audit within the allotted time.**

If the Subrecipient expends less than One Million Dollars (\$1,000,000.00) a year in federal funds (all sources), then they are exempt from Single Audit requirement for that year; however, records must be available for review or audit by appropriate officials of the federal agency, pass-through entity and the General Accounting Office.

Subrecipient is required to submit a 990 Tax Return (Return of Organization Exempt from Income Tax) for the most recent fiscal year within six (6) months if submitting a Financial Report or within nine (9) months if submitting a Financial Audit. If the Subrecipient is not classified as an exempt entity as defined in 2 CFR 200 – Uniform Administrative Requirements, Cost Principles, and Audit Requirements for Federal Awards, the Subrecipient will not be awarded grant funds.

If applicable, Subrecipient agrees to cooperate with County relating to any inquiries regarding the Financial Audit or Financial Report and Subrecipient acknowledges that a Financial Audit or Financial Report shall be provided to County at the expense of the Subrecipient. Financial Audit or Financial Report shall be available to County staff, and any and all applicable federal agencies, and be of unrestricted access, as listed in 24 CFR Part 85.42.

4. Cost Principles

Subrecipient shall administer its program in conformance with 2 CFR 200 – Uniform Administrative Requirements, Cost Principles, and Audit Requirements for Federal Awards, as applicable, for all costs incurred whether charged on a direct or indirect basis.

B. Documentation and Record-Keeping

1. Records to Be Maintained

Subrecipient shall maintain all records that are pertinent to the activities to be funded under this Agreement, including but not limited to:

- a. Records providing a full description of each activity undertaken;
- b. Records required to document the acquisition, improvement, use or disposition of real property acquired or improved with CDBG assistance;
- c. Records documenting compliance with the fair housing and equal opportunity components of the CDBG program; and
- d. Financial records as required by 24 CFR 570.502, and 2 CFR 200 – Uniform Administrative Requirements, Cost Principles, and Audit Requirements for Federal Awards.

2. Client Data

Subrecipient shall maintain client data demonstrating client eligibility for services provided. Such data shall include, but not be limited to a signed and dated verification of income statement, or other basis for determining eligibility, and description of service provided. Such information shall be made available to County monitors or their designees for review upon request.

3. National Objectives

Subrecipient agrees to maintain documentation that demonstrates that the activities carried out with funds provided under this Agreement benefit low/moderate income persons, as defined in 24 CFR 570.208.

C. Procurement

1. Compliance

Subrecipient shall comply with current County policy concerning the purchase of equipment and shall maintain an inventory record of all non-expendable personal property as defined by such policy as may be procured with funds provided herein. All program assets (unexpended program income, property, equipment, etc.) shall revert to the County upon termination of this Agreement. As necessary, the procurement procedures and related documents involving all purchases with grant funds are subject to review and oversight by the County's Contract Audit, Legal, and Purchasing Department.

2. OMB Standards

Subrecipient shall procure materials in accordance with the requirements of 2 CFR 200 – Uniform Administrative Requirements, Cost Principles, and Audit Requirements for Federal Awards, Procurement Standards, and shall subsequently follow, Property Management Standards, covering utilization and disposal of property. Copies of said circulars are provided and by execution of this Agreement, Subrecipient acknowledges their receipt.

D. Amendments

The County or Subrecipient may amend this Agreement at any time provided that such amendments are executed in writing and signed by a duly authorized representative of both organizations.

4. **NON-DISCRIMINATION:**

No person shall be excluded from or denied the benefits of Subrecipient's service on the basis of age, race, color, religion, creed, national origin, gender identity, sex, marital status, disability, sexual orientation or, with respect to the sale, lease, rental, use or occupancy of real property or housing accommodations, the presence or absence of dependents, familial status or public assistance source of income. All current and prospective project beneficiaries must, however, be persons in need of the programs provided by Subrecipient.

5. **SECTION 504 COMPLIANCE:**

No otherwise qualified individual with handicaps shall, solely by reason of his/her handicap, be excluded from participation in, be denied the benefits of, or be subjected to discrimination under any program or activity receiving federal financial assistance. This includes, but is not limited to, programs and/or activities related to housing, employment, and the delivery of services.

6. **EQUAL EMPLOYMENT OPPORTUNITY, FAIR HOUSING AND DRUG-FREE WORKPLACE:**

The subrecipient certifies that it is an "Equal Opportunity Employer" and that it will comply with the Texas Human Rights Commission Act, and all applicable HUD regulations pertaining to equal opportunity and affirmative action in employment. Further, the SUBRECIPIENT shall ensure that all contracts for work under this Agreement contain appropriate equal employment opportunity statements.

SUBRECIPIENT shall comply with all provisions of 24 CFR Part 100-115, which implement the Fair Housing Act. This Act prohibits discrimination in the sale or rental of housing, the financing of housing or the provision of brokerage services against any person on the basis of race, color, religion, sex, national origin, handicap or familial status.

In addition, SUBRECIPIENT certifies it will provide a drug-free workplace as defined in 24 CFR Part 24, subpart F and/or follow the requirements of 24 CFR 92.350.

7. **SECTION 3:**

Subrecipient agrees to comply with Section 3 requirements, the regulations set forth in 24 CFR 135, and to include the following language in all subcontracts executed under this Agreement:

- A. The work to be performed under this contract is subject to the requirements of Section 3 of the Housing and Urban Development Act of 1968, as amended, 12 U.S.C. 1701u (Section 3). The purpose of Section 3 is to ensure that employment and other economic opportunities generated by HUD assistance or HUD-assisted projects covered by Section 3 shall, to the greatest extent feasible, be directed to low- and very low-income persons, particularly persons who are recipients of HUD assistance for housing.
- B. The parties to this contract agree to comply with HUD's regulations in 24 CFR part 135, which implement Section 3. As evidenced by their execution of this contract, the parties to this contract certify that they are under no contractual or other impediment that would prevent them from complying with the part 135 regulations.
- C. The contractor agrees to send to each labor organization or representative of workers with which the contractor has a collective bargaining agreement or other understanding, if any, a notice advising the labor organization or workers' representative of the contractor's commitments under this Section 3 clause, and will post copies of the notice in conspicuous places at the work site where both employees and applicants for training and employment positions can see the notice. The notice shall describe the Section 3 preference, shall set forth minimum number and job titles subject to hire, availability of apprenticeship and training positions, the qualifications for each; and the name and location of the person(s) taking applications for each of the positions; and the anticipated date the work shall begin.
- D. The contractor agrees to include this Section 3 clause in every subcontract subject to compliance with regulations in 24 CFR part 135, and agrees to take appropriate actions, as provided in an applicable provision of the subcontract or in this Section 3 clause, upon a finding that the subcontractor is in violation of the regulations in 24 CFR part 135. The contractor will not subcontract with any subcontractor where the contractor has notice or knowledge that the subcontractor has been found in violation of the regulations in 24 CFR part 135.
- E. The contractor will certify that any vacant employment positions, including training positions, that are filled (1) after the contract is selected but before the contract is executed, and (2) with persons other than those to whom the regulations of 24 CFR part 135 require employment opportunities to be directed, were not filled to circumvent the contractor's obligations under 24 CFR part 135.
- F. Noncompliance with HUD's regulations in 24 CFR part 135 may result in sanctions, termination of this contract for default, and debarment or suspension from future HUD assisted contracts.
- G. With respect to work performed in connection with Section 3 covered Indian housing assistance, section 7(b) of the Indian Self-Determination and Education Assistance Act (25 U.S.C. 450e) also applies to the work to be performed under this contract. Section 7(b) requires that to the greatest extent feasible (i) preference and opportunities for

training and employment shall be given to Indians, and (ii) preference in the award of contracts and subcontracts shall be given to Indian organizations and Indian-owned Economic Enterprises. Parties to this contract that are subject to the provisions of Section 3 and section 7(b) agree to comply with Section 3 to the maximum extent feasible, but not in derogation of compliance with section 7(b).

8. **WOMEN AND MINORITY-OWNED BUSINESS ENTERPRISES:**

Subrecipient will use its best efforts to afford minority and women-owned business enterprises (at least fifty-one (51) percent owned and controlled by minority group members or women) the maximum practicable opportunity to participate in the performance of this Agreement.

9. **LABOR:**

Construction projects funded under the CDBG program in excess of \$2,000 shall comply with the labor provisions outlined in 24 CFR 570.603. Subrecipient will comply with Davis-Bacon Act (40 U.S.C. 276a-276a-5). Such contracts must also be subject to the overtime provisions, as applicable, of the Contract Work Hours and Safety Standards Act (40 U.S.C. 327-332). The Subrecipient agrees to adhere to said provisions and will not use suspended or debarred contractors.

10. **ENVIRONMENTAL ASSESSMENT AND HISTORIC PRESERVATION:**

Subrecipient shall assist the County in complying with all applicable environmental assessment and historic preservation requirements of HUD and the State Historic Preservation Officer of Texas.

11. **LEAD-BASED PAINT POISONING PREVENTION:**

Subrecipient shall comply with requirements of Section 302 of the Lead-Based Paint Poisoning Prevention Act and HUD regulations thereunder (24 CFR Part 570) insofar as they apply to the performance of this Agreement.

12. **ELIGIBILITY RESTRICTIONS FOR CERTAIN RESIDENT ALIENS (570.613):**

1. Restriction The subrecipient agrees to comply with 24 CFR 570.613, which states that certain newly legalized aliens, as described in 24 CFR part 5 subpart E are not eligible to apply for benefits under covered activities funded by the County's CDBG programs. "Benefits" under this section means financial assistance, public services, jobs and access to new or rehabilitated housing and other facilities funded through the County's CDBG programs. "Benefits" do not include relocation services and payments to which displacees are entitled by law.

2. Covered Activities "Covered activities" under this section means activities meeting the requirements of Sec. 570.208(a) that either:

- a. Have income eligibility requirements limiting the benefits exclusively to low and moderate income persons; or
- b. Are targeted geographically or otherwise to primarily benefit low and moderate income persons (excluding activities serving the public at large, such as sewers,

roads, sidewalks, and parks), and that provide benefits to persons on the basis of an application.

3. Limitation on Coverage

The restrictions under this section apply only to applicants for new benefits not being received by covered resident aliens as of the effective date of this agreement.

4. Compliance

Compliance can be accomplished by the subrecipient obtaining certification as provided in 24 CFR part 5 subpart E evidencing citizenship or eligible immigration status.

13. **TERMINATION OF AGREEMENT FOR CAUSE:**

If Subrecipient fails to fulfill its obligations under this Agreement in a timely and proper manner, or if Subrecipient violates any of the terms, agreements or stipulations of this Agreement, the County shall thereupon have the right to terminate this Agreement by giving written notice to Subrecipient of such termination, specifying the default or defaults, and stating that this Agreement shall be terminated 30 days after the giving of such notice unless such default or defaults are remedied within such cure period. The County shall be obligated to make no payment due hereunder after it gives said notice unless the defaults are remedied with said 30-day period. In the event of such termination, Subrecipient shall promptly repay to the County the full grant amount or that portion of the amounts that have been disbursed to Subrecipient prior to such termination.

14. **TERMINATION OF AGREEMENT FOR CONVENIENCE:**

This Agreement may be terminated in whole or in part upon the mutual agreement of the parties hereto, in which case the County and Subrecipient shall agree upon the termination conditions, including the effective date, the disposition of contract amounts, and in the case of partial termination, the portion to be terminated. However, if, in the case of partial termination, the County determines that the remaining portion of the award will not accomplish the purposes for which the award was made, and the award is terminated in its entirety, Subrecipient shall promptly repay to the County the full grant amount or that portion of the amount which has been disbursed to Subrecipient prior to such termination.

15. **INTEREST OF CERTAIN FEDERAL AND OTHER OFFICIALS:**

- A. No member or delegate to the Congress of the United States, and no resident Commissioner, shall be admitted to any share or part of this Agreement, or to any benefit to arise herefrom.
- B. No member of the governing body of the County, no officer, employee, official or agent of the County, or other local public official who exercises any functions or responsibilities in connection with the review, approval or carrying out of the Project to which this Agreement pertains, shall have any private interest, direct or indirect, in this Agreement.

- C. No federal funds appropriated under this Agreement shall be paid, by or on behalf of Subrecipient, to any person for influencing or attempting to influence a member of Congress, an officer or employee of Congress or any federal agency in connection with the awarding of any federal contract, the making of any federal grant, the making of any federal loan, the entering into of any cooperative agreement, and the extension, continuation, renewal, amendment or modification of any federal contract, grant, loan or agreement.
- D. If any funds other than federal appropriated funds have been paid or will be paid to any person for influencing or attempting to influence an officer or employee of any agency, a Member of Congress, an officer or employee of Congress, or an employee of a Member of Congress in connection with this federal agreement, Subrecipient shall complete and submit Standard Form-LLL, "Disclosure Form to Report Lobbying," in accordance with its instructions.
- E. Subrecipient shall require that the language of this certification be included in the award documents for all sub-Subrecipients and that all sub-Subrecipients shall certify and disclose accordingly.

16. **CONFLICT OF INTEREST:**

Subrecipient covenants that it has no interest and shall not acquire any interest, direct or indirect, which would conflict in any manner or degree with the performance of the services to be undertaken through this Agreement. Subrecipient further covenants that in the performance of this Agreement, no person having such an interest shall be employed by Subrecipient.

17. **GRANTOR RECOGNITION:**

All activities, facilities, and items utilized pursuant to this Agreement shall be prominently labeled as CDBG funded. In addition, Subrecipient will include a reference to the support provided herein in all publications made possible with funds made available under this Agreement.

18. **ASSIGNABILITY:**

Subrecipient shall not assign or transfer any interest in this Agreement without the prior written approval of the County. Any assignment made without such consent shall be void. This Agreement shall be binding upon and shall inure to the benefit of the successors and assigns of the parties hereto.

19. **HOLD HARMLESS PROVISION:**

Subrecipient shall indemnify, defend and hold harmless the County, its officers, employees and agents from all liability, loss, cost, damage and expense (including reasonable attorney's fees and court costs) resulting from or incurred by reason of any actions based upon the negligent acts or omissions of Subrecipient's employees or agents during the performance of this Agreement.

20. **SEVERABILITY CLAUSE:**

If any one or more of the provisions contained in this Agreement are held to be invalid, illegal, or unenforceable, this Agreement shall be deemed severable and the remainder of the Agreement shall remain in full force and effect.

21. **LIMITATIONS OF COUNTY LIABILITY - DISCLAIMER OF RELATIONSHIP:**

The County shall not be liable to Subrecipient, or to any party, for completion of or failure to complete any improvements which are parts of the Project. Nothing contained in this Agreement, nor any act or omission of the County or Subrecipient, shall be construed to create any special duty, relationship, third-party beneficiary, respondent superior, limited or general partnership, joint venture, or any association by reason of Subrecipient's involvement with the County.

IN WITNESS WHEREOF, the Parties hereto have executed this Agreement on this _____ day of _____, 2026.

Williamson County, Texas

By: _____

Steve Snell
County Judge/Authorized Official

ACKNOWLEDGMENT

STATE OF TEXAS)
) SS:
WILLIAMSON COUNTY)

On this _____ day of _____, 2026, before me, Andrea Schiele, a Notary Public in and for said State, personally appeared Steve Snell, to me personally known, who being by me duly sworn, did say that he is the County Judge/Authorized Official of said County executing the within and foregoing instrument that the seal affixed hereto is the seal of said County, and that the said Steve Snell acknowledged the execution of said instrument to be the voluntary act and deed of said County, by it and by him voluntarily executed.

Notary Public in and for Williamson County, Texas

EXHIBIT A

**TO AGREEMENT BETWEEN WILLIAMSON COUNTY
AND OPERATION LIBERTY HILL
FOR THE USE OF COMMUNITY DEVELOPMENT BLOCK GRANT FUNDS
FISCAL YEAR 2025 FUNDING**

1. PROJECT DESCRIPTION AND SCOPE OF SERVICES:

A. Subrecipient to provide temporary housing in local hotels when the weather is extremely cold or extremely hot; for people living in a place not meant for human habitation; for people coming out of an emergency shelter; for people who need transitional or supportive housing for homeless persons who originally came from the streets or emergency shelters; for people who had been in any of the previous three places but is spending 30 days or less in a hospital or other institution; for people who are being evicted within a week from a private residence and they have nowhere else to go nor the resources or support to get housed; for people who are being discharged from an institution where they resided for more than 30 consecutive days and have nowhere else to go nor the resources or support to get housed; and, people fleeing a domestic violence situation with nowhere else to go nor the resources or support to get housed.

B. Upon request, the County will provide technical assistance to the subrecipient concerning compliance with the terms of this Agreement. The subrecipient shall be responsible for all bidding procedures and subcontractual arrangements. All procedures shall be carried out in accordance with all Federal, State and local standards, and shall be monitored by the County.

C. The Project shall be completed in compliance with all applicable state and local codes. Upon completion, this Project shall be operated in compliance with all applicable federal, state and local laws. Subrecipient agrees the funding shall be used solely for the purpose of costs as detailed in Part I.1.A. of this Agreement.

2. TIME OF PERFORMANCE:

Subrecipient shall perform according to the following schedule:

Program Element

- | | |
|------------------------|--|
| 1. February-March 2026 | Award of funds and contract with Williamson County |
| 2. March-December 2026 | Program Implementation |

3. Monitoring Period

To be determined based on statement below

Records are to be retained for four years from the date of submission of the County's CAPER in which the specific activity is reported for the last time, unless there is litigation, claims, audit, negotiation, or other actions involving the records, which has started before expiration of the four year period. In such cases, the records must be retained until completion of the action and resolution of all issues which arise from it or the end of the regular four year period, whichever is longer.

3. **PROPOSED PROJECT BUDGET (see attached HUD budget):**

	<u>CDBG Amount</u>	<u>Subrecipient Amount</u>
A. <u>Program Implementation</u>	\$20,000	_____
B. <u>Eligible equipment</u> (as outlined in 24 CFR 570.207(1))	_____	_____
C. <u>Property Acquisition</u>	_____	_____
Total	\$20,000	

EXHIBIT B
Williamson County Community Development Block Grant Audit Requirements

Williamson County Subrecipients will adhere to the following guidelines with regard to audit requirements:

Subrecipient agrees to comply with the applicable requirements and standards as set forth in 2 CFR 200 – Uniform Administrative Requirements, Cost Principles, and Audit Requirements for Federal Awards.

Subrecipient agrees to furnish County with a current Financial Report (financial statements) within six (6) months from the end of its fiscal year covering the period of this Agreement that includes detailed receipts and disbursement of payments to Subrecipient hereunder. Future and unused grant funds will automatically be forfeited if the Subrecipient fails to submit a Financial Report.

However, if Subrecipient expends One Million Dollars (\$1,000,000.00) or more in federal funds (all sources), Subrecipient must, within nine (9) months from the end of its fiscal year, supply County with a single audit and is required to submit their audit report to the Federal Audit Clearinghouse (FAC) within the earlier of 30 days after the receipt of the auditor's report, or within 9 months after the end of the audit period. Grant funds will automatically be forfeited if the Subrecipient fails to submit an audit within the allotted time.

If the Subrecipient expends less than One Million Dollars (\$1,000,000.00) a year in federal funds (all sources), then they are exempt from the Single Audit requirements for that year; however, records must be available for review or audit by appropriate officials of the federal agency, pass-through entity and the General Accounting Office.

If applicable, Subrecipient is required to submit a 990 Tax Return (Return of Organization Exempt from Income Tax) for the most recent fiscal year within six (6) months if submitting a Financial Report or within nine (9) months if submitting a Financial Audit. If the Subrecipient is not classified as an exempt entity as defined in 2 CFR 200 – Uniform Administrative Requirements, Cost Principles, and Audit Requirements for Federal Awards, the Subrecipient will not be awarded grant funds.

If applicable, Subrecipient agrees to cooperate with County relating to any inquiries regarding the Financial Audit or Financial Report and Subrecipient acknowledges that a Financial Audit or Financial Report shall be provided to County at the expense of the Subrecipient. Financial Audit or Financial Report shall be available to County staff, and any and all applicable federal agencies, and be of unrestricted access, in accordance with 24 CFR Part 85.42 and 24 CFR Part 84.53 as applicable.

The Williamson County CDBG office will issue letters to remind Subrecipients of the audit requirements and request timely submission. Letters will be issued on or around January 5 of each year. If no response is received, a second letter will be issued on or around February 15 of each year. If no response is received, a third request will be made approximately two weeks following. If no response is received by March 15, a final notification will be issued advising the subrecipient of suspension of reimbursement and future funding pending receipt of requested information.

Failure to follow these guidelines could result in the forfeit of future Williamson County CDBG funds and/or repayment of Williamson County CDBG funds already utilized.

Upon receipt of the required audit documents, the Williamson County Community Development Block Grant office will do an initial review to identify findings that affect the Williamson County CDBG program or any cross-cutting findings that could affect future funding. The CDBG office will also request a review by the Williamson County Auditor's office.

In the event of a finding, Williamson County will issue a letter requesting additional information regarding the finding and the intentions of the Subrecipient to remedy the finding. Working with the Williamson County Auditor's office, the CDBG office will determine next steps to ensure that all federal, state, or local laws/statutes are met.

If a Subrecipient is unable to provide required audit documentation and has utilized CDBG funding, Williamson County will have the option to request repayment and recapture unused funds. If a Subrecipient is unable to provide required audit documentation and has not utilized CDBG funding, Williamson County will not issue funding until requirements are met or will reallocate funds to an alternate project if necessary.

EXHIBIT C

Policy Requirements

If applicable:

1. The Recipient shall not use grant funds to promote “gender ideology,” as defined in Executive Order(E.O.) 14168, Defending Women from Gender Ideology Extremism and Restoring Biological Truth to the Federal Government;
2. The Recipient agrees that its compliance in all respects with all applicable Federal anti-discrimination laws is material to the U.S. Government’s payment decisions for purposes of section3729(b)(4) of title 31, United States Code;
3. The Recipient certifies that it does not operate any programs that violate any applicable Federal anti-discrimination laws, including Title VI of the Civil Rights Act of 1964;
4. The Recipient shall not use any grant funds to fund or promote elective abortions, as required by E.O. 14182, Enforcing the Hyde Amendment; and that,
5. Notwithstanding anything in the NOFO or Application, this Grant shall not be governed by Executive Orders revoked by E.O. 14154, including E.O. 14008, or NOFO requirements implementing Executive Orders that have been revoked.
6. The Recipient must administer its grant in accordance with all applicable immigration restrictions and requirements, including the eligibility and verification requirements that apply under title IV of the Personal Responsibility and Work Opportunity Reconciliation Act of 1996, as amended (8 U.S.C.1601-1646) (PRWORA) and any applicable requirements that HUD, the Attorney General, or the U.S. Citizenship and Immigration Services may establish from time to time to comply with PRWORA, Executive Order 14218, or other Executive Orders or immigration laws.
7. No state or unit of general local government that receives funding under this grant may use that funding in a manner that by design or effect facilitates the subsidization or promotion of illegal immigration or shields illegal aliens from deportation, including by maintaining policies or practices that materially impede enforcement of federal immigration statutes and regulations.
8. The Recipient must use SAVE, or an equivalent verification system approved by the Federal government, to prevent any Federal public benefit from being provided to an ineligible alien who entered the United States illegally or is otherwise unlawfully present in the United States.
9. Faith-based organizations may be subrecipients for funds on the same basis as any other organization. Recipients may not, in the selection of subrecipients, discriminate against an organization based on the organization’s religious character, affiliation, or exercise.

PROGRAM-SPECIFIC REQUIREMENTS

Assistance Listing 14.218, Community Development Block Grant Program for Entitlement Communities

1. Environmental Review. The Recipient agrees to assume all the responsibilities for environmental review, decision making, and actions, as specified and required in regulations issued by the Secretary pursuant to section 104(g) of title I of the Housing and Community Development Act of 1974 and published in 24 C.F.R. part 58; except that if the Recipient is a state, the Recipient must require the unit of general local government to assume that responsibility and must comply with the state’s responsibilities under 24 C.F.R. 58.4.

2. Public Use. The Recipient shall ensure that no CDBG funds are used to support any Federal, State, or local projects that seek to use the power of eminent domain, unless eminent domain is employed only for public use. For the purposes of this requirement, public use shall not be construed to include economic development that primarily benefits private entities. Any use of funds for mass transit, railroad, airport, seaport, or highway projects as well as utility projects that benefit or serve the general public (including energy-, communication-, water-, and wastewater-related infrastructure), other structures designated for use by the general public or which have other common-carrier or public-utility functions that serve the general public and are subject to regulation and oversight by the government, and projects for the removal of an immediate threat to public health and safety or brownfield as defined in the Small Business Liability Relief and Brownfields Revitalization Act (Pub. Law No. 107–118) shall be considered a public use for purposes of eminent domain.

3. Prohibition on Selling, Trading, and Transferring Funds. The Recipient or unit of general local government that directly or indirectly receives CDBG funds may not sell, trade, or otherwise transfer all or any such portion of such funds to another such entity in exchange for any other funds, credits or non-Federal considerations, but must use such funds for activities eligible under title I of the Housing and Community Development Act of 1974.

4. Construction of Water and Sewer Facilities. Notwithstanding any other provision of this agreement, the Recipient may not obligate or expend award funds to plan or construct water or sewer facilities, including any new or revised activities, until after 1) it completes the review procedures required under Executive Order 12372, Intergovernmental Review of Federal Programs, and 24 C.F.R. part 52 and 2) HUD provides written notice of the release of funds.

5. Funds for For-Profit Entities. Under 42 U.S.C. § 5305(a)(17), CDBG funds may not be provided to a for-profit entity unless such activity or project has been evaluated and selected in accordance with Appendix A to 24 C.F.R. § 570, Guidelines and Objectives for Evaluating Project Costs and Financial Requirements.

6. Violence Against Women Act. The Recipient will comply with the right to report crime and emergencies protections at 34 U.S.C. § 12495 of the Violence Against Women Act.

Commissioners Court - Regular Session

10.

Meeting Date: 03/10/2026

Approval of Ratification of Moving Service Contract #2026-165 with Central Transportation Systems for Elections Equipment Transportation Services for the Elections Department

Submitted For: Joy Simonton

Submitted By: Jesel Vigil, Purchasing

Department: Purchasing

Agenda Category: Consent

Information

Agenda Item

Discuss, consider, and take appropriate action on approving and ratifying the Moving Services Contract #2026-165 between Williamson County and Central Transportation Systems for election equipment moving service in the amount of \$32,850.00 and authorizing the execution of the service contract pursuant to TX SmartBuy Contract #TXMAS-22-96201.

Public Background

Fiscal Impact

From/To	Acct No.	Description	Amount
---------	----------	-------------	--------

Attachments

Form Review

Inbox

County Judge Exec Asst.

Form Started By: Jesel Vigil

Final Approval Date: 02/24/2026

Reviewed By

Delia Colon

Date

02/24/2026 09:31 AM

Started On: 02/13/2026 09:41 AM

Commissioners Court - Regular Session

11.

Meeting Date: 03/10/2026

Approval of contract 2026-173 - Silver Maintenance Agreement for Folder/Inserter for the Elections Department

Submitted For: Joy Simonton

Submitted By: Justin Lee, Purchasing

Department: Purchasing

Agenda Category: Consent

Information

Agenda Item

Discuss, consider, and take appropriate action on approving a Silver Maintenance Agreement with Quadient USA Inc. for the DS40i Folder Inserter, in the amount of \$1,675.31, and authorizing the execution of the Agreement.

Public Background

Fiscal Impact

From/To	Acct No.	Description	Amount
---------	----------	-------------	--------

Attachments

Form Review

Inbox

County Judge Exec Asst.

Form Started By: Justin Lee

Final Approval Date: 03/03/2026

Reviewed By

Delia Colon

Date

03/03/2026 08:29 AM

Started On: 02/24/2026 09:43 AM

Commissioners Court - Regular Session

12.

Meeting Date: 03/10/2026

Authorize Issuing Advertisement for RFSQ #26RFSQ31 Jail Inmate Dental Services for the Corrections Department

Submitted For: Joy Simonton

Submitted By: Jesel Vigil, Purchasing

Department: Purchasing

Agenda Category: Consent

Information

Agenda Item

Discuss, consider, and take appropriate action on authorizing the Purchasing Agent to advertise and receive sealed responses for qualifications for Jail Inmate Dental Services, under RFSQ #26RFSQ31.

Public Background

Fiscal Impact

From/To	Acct No.	Description	Amount
---------	----------	-------------	--------

Attachments

Form Review

Inbox

County Judge Exec Asst.

Form Started By: Jesel Vigil

Final Approval Date: 03/02/2026

Reviewed By

Delia Colon

Date

03/02/2026 12:06 PM

Started On: 02/23/2026 03:56 PM

Commissioners Court - Regular Session

13.

Meeting Date: 03/10/2026

Authorize Issuing Advertisement for IFB #26IFB24 Pharmaceuticals and Clinic Supplies for the Williamson County Animal Shelter

Submitted For: Joy Simonton

Submitted By: Sandra Malcolm, Purchasing

Department: Purchasing

Agenda Category: Consent

Information

Agenda Item

Discuss, consider, and take appropriate action on authorizing the Purchasing Agent to advertise and receive sealed solicitations for Pharmaceuticals and Clinic Supplies for the Williamson County Animal Shelter, under IFB #26IFB24.

Public Background

Fiscal Impact

From/To	Acct No.	Description	Amount
---------	----------	-------------	--------

Attachments

Form Review

Inbox

County Judge Exec Asst.

Form Started By: Sandra Malcolm

Final Approval Date: 03/02/2026

Reviewed By

Delia Colon

Date

03/02/2026 11:59 AM

Started On: 02/20/2026 02:23 PM

Commissioners Court - Regular Session

14.

Meeting Date: 03/10/2026

Approval of Addendum #2026-157 with CDW Government LLC for Engineering Consulting Services for the Information Systems Department

Submitted For: Joy Simonton

Submitted By: Jesel Vigil, Purchasing

Department: Purchasing

Agenda Category: Consent

Information

Agenda Item

Discuss, consider, and take appropriate action on approving Addendum #2026-157 between Williamson County and CDW Government, LLC for Engineering and Consulting Services for as-needed support in the amount of \$10,200 and authorizing the execution of the addendum pursuant to DIR Contract #DIR-CPO-5176.

Public Background

Fiscal Impact

From/To	Acct No.	Description	Amount
---------	----------	-------------	--------

Attachments

Form Review

Inbox

County Judge Exec Asst.

Form Started By: Jesel Vigil

Final Approval Date: 03/02/2026

Reviewed By

Delia Colon

Date

03/02/2026 11:24 AM

Started On: 02/06/2026 03:51 PM

Commissioners Court - Regular Session

15.

Meeting Date: 03/10/2026

Authorize Issuing 26RFSQ28 Planner, Landscape Architecture, Architecture & Engineer (PLAE) Pool for Facilities Management

Submitted For: Joy Simonton

Submitted By: Michelle McKinney, Purchasing

Department: Purchasing

Agenda Category: Consent

Information

Agenda Item

Discuss, consider, and take appropriate action on authorizing the Purchasing Agent to advertise and receive sealed responses for PLAE, Planner, Landscape Architecture, Architecture & Engineer Pool, under RFSQ # 26RFSQ28.

Public Background

Fiscal Impact

From/To	Acct No.	Description	Amount
---------	----------	-------------	--------

Attachments

Form Review

Inbox

County Judge Exec Asst.

Form Started By: Michelle McKinney

Final Approval Date: 03/02/2026

Reviewed By

Delia Colon

Date

03/02/2026 12:07 PM

Started On: 02/26/2026 10:05 AM

Commissioners Court - Regular Session

16.

Meeting Date: 03/10/2026

Schwertner Community Center

Submitted For: Valerie Covey

Submitted By: Rachel Rull, Commissioner Pct. #3

Department: Commissioner Pct. #3

Agenda Category: Consent

Information

Agenda Item

Discuss, consider, and take appropriate action authorizing funding in the amount of \$44,913 from the Williamson County Community Recreation Facility Fund to construct repairs to the parking lot at the Schwertner Community Center.

Public Background

Fiscal Impact

From/To	Acct No.	Description	Amount
---------	----------	-------------	--------

Attachments

No file(s) attached.

Form Review

Inbox

County Judge Exec Asst.

Form Started By: Rachel Rull

Final Approval Date: 03/04/2026

Reviewed By

Andrea Schiele

Date

03/04/2026 11:03 AM

Started On: 02/25/2026 11:23 AM

Commissioners Court - Regular Session

17.

Meeting Date: 03/10/2026

Approval of the Agreement for Construction Services No. 2026-177 with J.T. Vaughn Construction, LLC for the Schwertner Community Club Parking Lot for Facilities Management

Submitted For: Joy Simonton

Submitted By: Michelle McKinney, Purchasing

Department: Purchasing

Agenda Category: Consent

Information

Agenda Item

Discuss, consider, and take appropriate action on approving the Agreement of Construction Services No. 2026-177 between Williamson County and J.T. Vaughn Construction, LLC for the Schwertner Community Parking Lot in the not-to-exceed amount of Forty-Four Thousand Nine Hundred and Thirteen Dollars (\$44,913.00) pursuant to OMNIA Cooperative Contract #R241607 and authorize execution of the agreement.

Public Background

Fiscal Impact

From/To	Acct No.	Description	Amount
---------	----------	-------------	--------

Attachments

Form Review

Inbox

County Judge Exec Asst.

Form Started By: Michelle McKinney

Final Approval Date: 03/02/2026

Reviewed By

Delia Colon

Date

03/02/2026 03:00 PM

Started On: 02/27/2026 08:06 AM

Commissioners Court - Regular Session

18.

Meeting Date: 03/10/2026

25IFB56 CR 313 Reconstruction – Change Order #1 (Adjust Quantities)

Submitted For: Matt Williamson

Submitted By: Jenifer Favreau, Infrastructure

Department: Infrastructure

Division: Road & Bridge

Agenda Category: Consent

Information

Agenda Item

Discuss, consider and take appropriate action regarding change order #1 for Project 25IFB56 CR 313 Reconstruction.

Public Background

This change order adjusts item quantities to the expected usages of the project.

Fiscal Impact

From/To	Acct No.	Description	Amount
---------	----------	-------------	--------

Attachments

Form Review

Inbox

County Judge Exec Asst.

Form Started By: Jenifer Favreau

Final Approval Date: 03/03/2026

Reviewed By

Delia Colon

Date

03/03/2026 04:31 PM

Started On: 03/03/2026 03:26 PM

Commissioners Court - Regular Session

Meeting Date: 03/10/2026

Revised Preliminary Plat for the Reserve at North Haven Subdivision (revision 1) – Pct 2

Submitted For: Adam Boatright

Submitted By: Misti Schulz, Infrastructure

Department: Infrastructure

Agenda Category: Consent

Information

Agenda Item

Discuss, consider, and take appropriate action on approval of the Revised Preliminary Plat for the Reserve at North Haven Subdivision (revision 1) – Precinct 2.

Public Background

This is the first revision to the preliminary plat of the Reserve at North Haven Subdivision that was last approved March 7th, 2023. Since the last approval, the developer has requested changes to the roadway and lot layout. This revision consists of an increase of 442 lots and 8,522 linear feet of new roads. With this revision, the Reserve at North Haven Subdivision consists of 515 single-family lots, 8 right-of-way lots, 7 open space lots, 5 open space/drainage lots, 5 right-of-way reserve lots, 2 irrigation/drainage/open space lots, 2 irrigation/open space lots, 1 wastewater/open space lot, 1 amenity lot, and 19,129 linear feet of new public roads to be maintained by Municipal Utility District 62 on 130.10 acres.

Timeline

- 2025-01-07 – initial submittal of the preliminary plat
- 2025-02-06 – 1st review complete with comments
- 2025-03-14 – 2nd submittal of preliminary plat
- 2025-03-28 – 2nd review complete with comments
- 2025-03-28 – 3rd submittal of preliminary plat
- 2025-04-11 – 3rd review complete with comments
- 2025-05-06 – 4th submittal of preliminary plat
- 2025-05-21 – 4th review complete with comments
- 2025-06-16 – 5th submittal of preliminary plat
- 2025-07-01 – 5th review complete with comments
- 2025-07-15 – 6th submittal of preliminary plat
- 2025-07-30 – 6th review complete with comments
- 2025-08-14 – 7th submittal of preliminary plat
- 2025-08-28 – 7th review complete with comments
- 2026-01-05 – 8th submittal of preliminary plat
- 2026-01-19 – 8th review complete with comments
- 2026-01-27 – 9th submittal of preliminary plat
- 2026-02-11 – 9th review complete with comments
- 2026-02-24 – 10th submittal of preliminary plat
- 2026-03-02 – 10th review complete with comments cleared
- 2026-03-03 – revised preliminary plat placed on the March 10th, 2026 Commissioners Court agenda for consideration.

Fiscal Impact

From/To	Acct No.	Description	Amount
---------	----------	-------------	--------

Attachments

Preliminary Plat - Reserve at North Haven

Form Review

Inbox

County Judge Exec Asst.

Form Started By: Misti Schulz

Final Approval Date: 03/04/2026

Reviewed By

Delia Colon

Date

03/04/2026 08:31 AM

Started On: 03/03/2026 09:01 AM

RESERVE AT NORTH HAVEN

PRELIMINARY PLAT

WILLIAMSON COUNTY, TX

Sheet Number	Sheet Title
1	COVER SHEET
2	PRELIMINARY PLAT (SHEET 1 OF 2)
3	PRELIMINARY PLAT (SHEET 2 OF 2)
4	ROW DEDICATION (SHEET 1 OF 3)
5	ROW DEDICATION (SHEET 2 OF 3)
6	ROW DEDICATION (SHEET 3 OF 3)
7	LOT SUMMARY
8	EXISTING HYDROLOGY MAP
9	PROPOSED HYDROLOGY MAP
10	PROPOSED UTILITIES (SHEET 1 OF 2)
11	PROPOSED UTILITIES (SHEET 2 OF 2)

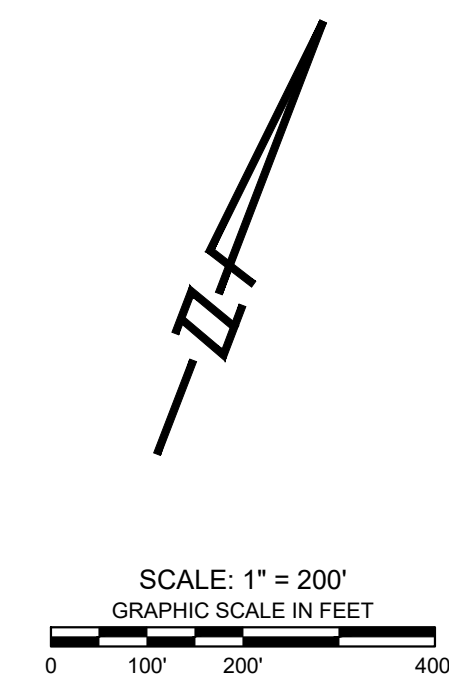
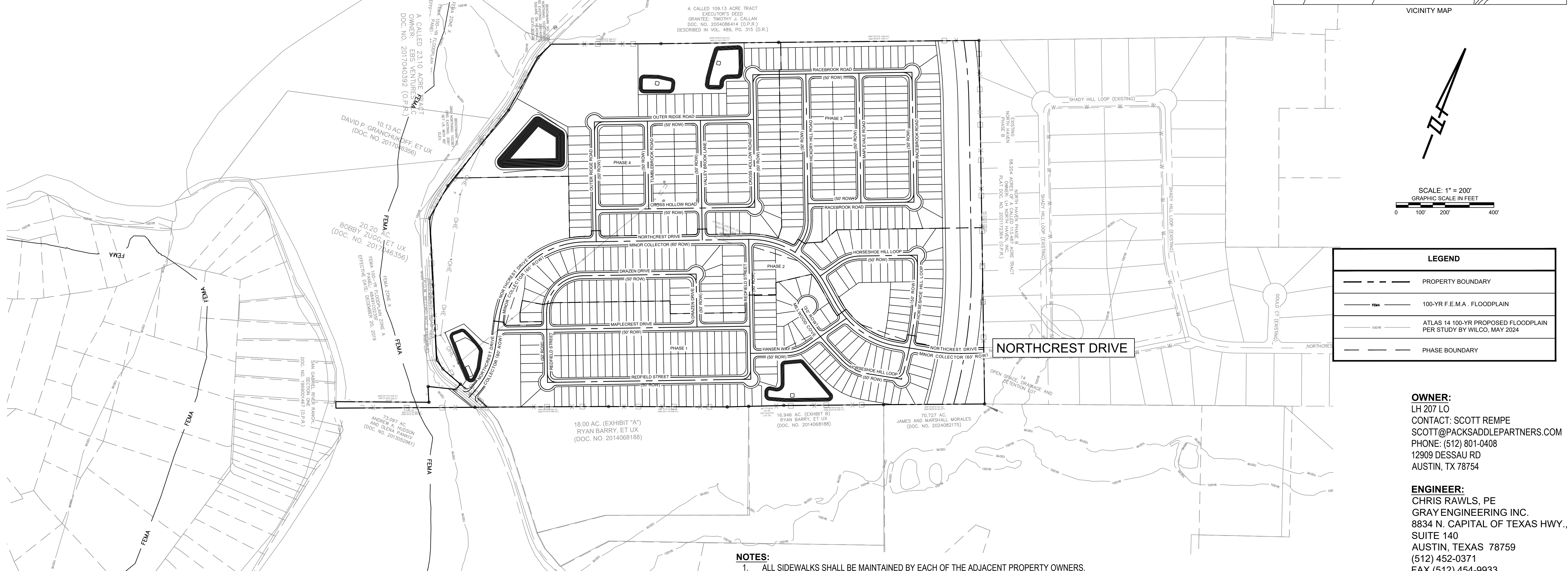
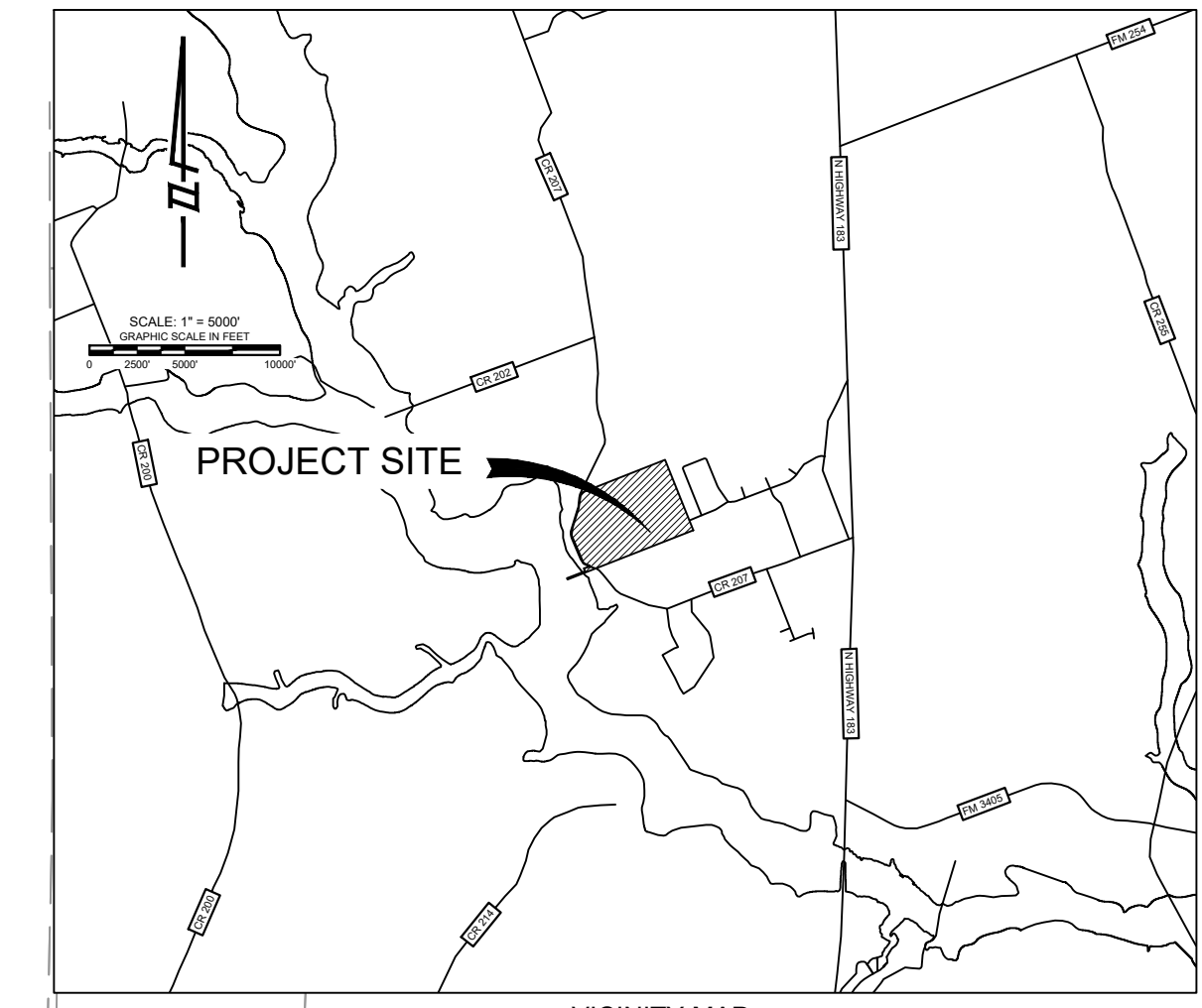

LEGEND	
	PROPERTY BOUNDARY
	100-YR F.E.M.A. FLOODPLAIN
	ATLAS 14 100-YR PROPOSED FLOODPLAIN PER STUDY BY WILCO, MAY 2024
	PHASE BOUNDARY

OWNER:
LH 207 LO
CONTACT: SCOTT REMPE
SCOTT@PACKSADDLEPARTNERS.COM
PHONE: (512) 801-0408
12909 DESSAU RD
AUSTIN, TX 78754

ENGINEER:
CHRIS RAWLS, PE
GRAY ENGINEERING INC.
8834 N. CAPITAL OF TEXAS HWY., SUITE 140
AUSTIN, TEXAS 78759
(512) 452-0371
FAX (512) 454-9933

SURVEYOR:
PAPE-DAWSON ENGINEERS
CONTACT: VALERIE ZURCHER, RPLS
EMAIL: VZURCHER@PAPE-DAWSON.COM
PHONE: (512) 454-8711
10801 NORTH MOPAC EXPRESSWAY
BUILDING 3 - SUITE 200
AUSTIN, TX 78759

TOTAL NUMBER OF LOTS:
NO. OF BLOCKS: 16
NO. OF 40' LOTS: 402
NO. OF 50' LOTS: 113
NO. OF SINGLE FAMILY LOTS: 515
NO. NON RESIDENTIAL LOTS: 31

TOTAL LINEAR FOOTAGE OF STREETS:
19,129 LF
ORIGINAL SUBMITTAL DATE: JAN. 7 2025

STREET DESIGN TABLE									
STREET NAME	CLASSIFICATION	DESIGN SPEED	LENGTH	ROW WIDTH	PAVEMENT WIDTH	RURAL/URBAN	MAINTENANCE AUTHORITY	DRAINAGE TYPE	SIDEWALK
CROSS HOLLOW ROAD	LOCAL	25 MPH	1,644	50'	33' F-F	URBAN	MUD 62	CURB & GUTTER	4' BOTH SIDES
DRAZEN DRIVE	LOCAL	25 MPH	1,315	50'	33' F-F	URBAN	MUD 62	CURB & GUTTER	4' BOTH SIDES
HICKORY HILL ROAD	LOCAL	25 MPH	993	50'	33' F-F	URBAN	MUD 62	CURB & GUTTER	4' BOTH SIDES
HORSESHOE HILL LOOP	LOCAL	25 MPH	1,772	50'	33' F-F	URBAN	MUD 62	CURB & GUTTER	4' BOTH SIDES
MAPLECREST DRIVE	LOCAL	25 MPH	1,379	50'	33' F-F	URBAN	MUD 62	CURB & GUTTER	4' BOTH SIDES
MAPLEVALE ROAD	LOCAL	25 MPH	710	50'	33' F-F	URBAN	MUD 62	CURB & GUTTER	4' BOTH SIDES
MILLWOOD COVE	LOCAL	25 MPH	215	50'	33' F-F	URBAN	MUD 62	CURB & GUTTER	4' BOTH SIDES
OUTER RIDGE ROAD	LOCAL	25 MPH	1,525	50'	33' F-F	URBAN	MUD 62	CURB & GUTTER	4' BOTH SIDES
RACEBROOK ROAD	LOCAL	25 MPH	2,110	50'	33' F-F	URBAN	MUD 62	CURB & GUTTER	4' BOTH SIDES
REDFIELD STREET	LOCAL	25 MPH	2,166	50'	33' F-F	URBAN	MUD 62	CURB & GUTTER	4' BOTH SIDES
NORTHCREST DRIVE	MINOR COLLECTOR	35 MPH	3,124	60'	40' F-F	URBAN	MUD 62	CURB & GUTTER	4' BOTH SIDES
NORTHCREST DRIVE	COLLECTOR	35 MPH	461	60'	48' F-F	URBAN	MUD 62	CURB & GUTTER	4' BOTH SIDES
HANSEN WAY	LOCAL	25 MPH	580	50'	33' F-F	URBAN	MUD 62	CURB & GUTTER	4' BOTH SIDES
TUMBLEBROOK ROAD	LOCAL	25 MPH	480	50'	33' F-F	URBAN	MUD 62	CURB & GUTTER	4' BOTH SIDES
VALLEY BROOK LANE	LOCAL	25 MPH	655	50'	33' F-F	URBAN	MUD 62	CURB & GUTTER	4' BOTH SIDES
			19,129						

- NOTES:**
- ALL SIDEWALKS SHALL BE MAINTAINED BY EACH OF THE ADJACENT PROPERTY OWNERS.
 - ALL NON-RESIDENTIAL LOTS SHALL BE OWNED AND MAINTAINED BY THE MUD.
 - THIS SUBDIVISION IS VESTED TO THE WILLIAMSON COUNTY SUBDIVISION REGULATIONS DATED DECEMBER 7, 2021.
 - NO LOTS SMALLER THAN 50' IN WIDTH SHALL BE FURTHER SUBDIVIDED.
 - THE FRONT BUILDING SETBACK LINE ON ALL PUBLIC ROADS SHALL BE 25 FEET FROM THE EDGE OF THE RIGHT-OF-WAY, 10 FEET FROM THE BACK OF LOT LINE AND 5 FEET FROM THE SIDES OF LOT LINES. CORNER LOTS WILL BE 15 FT ON THE RIGHT-OF-WAY SIDE INSTEAD OF 5 FEET. THE BUILDING SETBACK LINE ON MAJOR HIGHWAYS AND ROADS SHALL BE 50 FEET FROM THE EDGE OF THE RIGHT-OF-WAY. (WCSR F1.2)
 - UTILITY PROVIDERS WILL BE:
ELECTRICAL: ONCOR
TELECOM: TIME WARNER CABLE / AT&T
WATER: GEORGETOWN UTILITY SYSTEM
WASTEWATER: WILLIAMSON COUNTY MUD NO. 62 OR NEXT AVAILABLE.
 - A PORTION OF THIS SUBDIVISION IS ENCROACHED BY A SPECIAL FLOOD HAZARD AREA(S) INUNDATED BY THE 100-YEAR (1% CHANCE) FLOOD AS IDENTIFIED BY THE U.S. FEDERAL EMERGENCY MANAGEMENT AGENCY FLOOD INSURANCE MAP, COMMUNITY PANEL NO. 48491C0235F, EFFECTIVE DATE DECEMBER 20, 2019 FOR WILLIAMSON COUNTY, TEXAS
 - THE PURPOSE OF THIS PRELIMINARY PLAT IS TO SHOW THE PROPOSED IMPROVEMENTS TO THE OWNER'S PROPERTY, INCLUDING THE EXISTING TOPOGRAPHY, TO EVALUATE THE EXISTING AND PROPOSED DRAINAGE PATTERS.
 - RESIDENTIAL DRIVEWAYS SHALL ONLY CONNECT TO AN INTERNAL PLATTED ROAD AND NOT TO CR 207, NORTHCREST DRIVE, OR CORRIDOR 12.
 - A FINAL PLAT WILL NOT BE APPROVED BY THE WILLIAMSON COUNTY COMMISSIONERS COURT FOR ANY PORTION OF THIS PRELIMINARY PLAT (A "PHASE") UNTIL THE OWNER HAS OBTAINED AND PROVIDED TO THE COUNTY EVIDENCE THAT IT HAS OBTAINED APPROPRIATE PERMIT FROM THE TCEQ TO DISPOSE OF WASTEWATER FOR THE BUILD-OUT OF THE PHASE AND PLANS AND SPECIFICATIONS FOR THE PROPOSED WASTEWATER COLLECTION AND TREATMENT FACILITIES FOR THE PHASE SHALL BE APPROVED BY ALL ENTITIES HAVING JURISDICTION OVER THE PROPOSED PROJECT.
 - EVERY DEED WITHIN THIS SUBDIVISION SHALL CONTAIN NOTICE THAT ALL ROADS WITHIN THIS SUBDIVISION ARE PRIVATE. WILLIAMSON COUNTY WILL NEVER ACCEPT OR MAINTAIN THE ROADS.
 - MUD 62 SHALL BE RESPONSIBLE FOR THE MAINTENANCE OF ROADWAYS WITHIN THE RESERVE AT NORTH HAVEN SUBDIVISION. THE MUD SHALL HAVE ASSESSMENT AUTHORITY TO ENSURE PROPER FUNDING FOR MAINTENANCE.

8834 N. Capital of Texas Hwy.
Suite 140
Austin, Texas 78759
(512) 452-0371
FAX (512) 454-9933
TBPELS FRM #2946

GRAY ENGINEERING

NO.	BY	DATE	REVISION DESCRIPTION

COVER SHEET

RESERVE AT NORTH HAVEN
PRELIMINARY PLAN
WILLIAMSON COUNTY, TX

PROJECT NO: 11838
DESIGNED BY: XXX
DRAWN BY: XXX
CHECKED BY: XXX

NOTICE:
ALTERATION OF A SEALED DRAWING WITHOUT PROPER NOTIFICATION TO THE RESPONSIBLE ENGINEER IS A VIOLATION OF THE TEXAS ENGINEERING PRACTICE ACT.

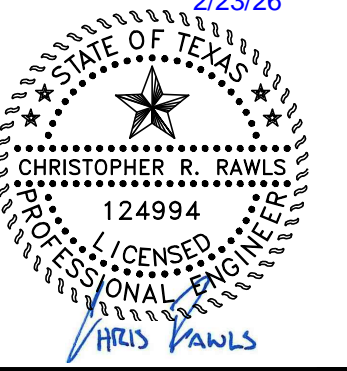

H:\PROJECTS\1737 - PACKSADDLE PARTNERS\1638 - PACKSADDLE LIBERTY HILL\CD\DWG SHEET 11838-C-PREL-COVER.DWG DATE: 2/23/2025 11:19:05 AM BY: GRAMLS

BLOCK P ROW DEDICATION 2

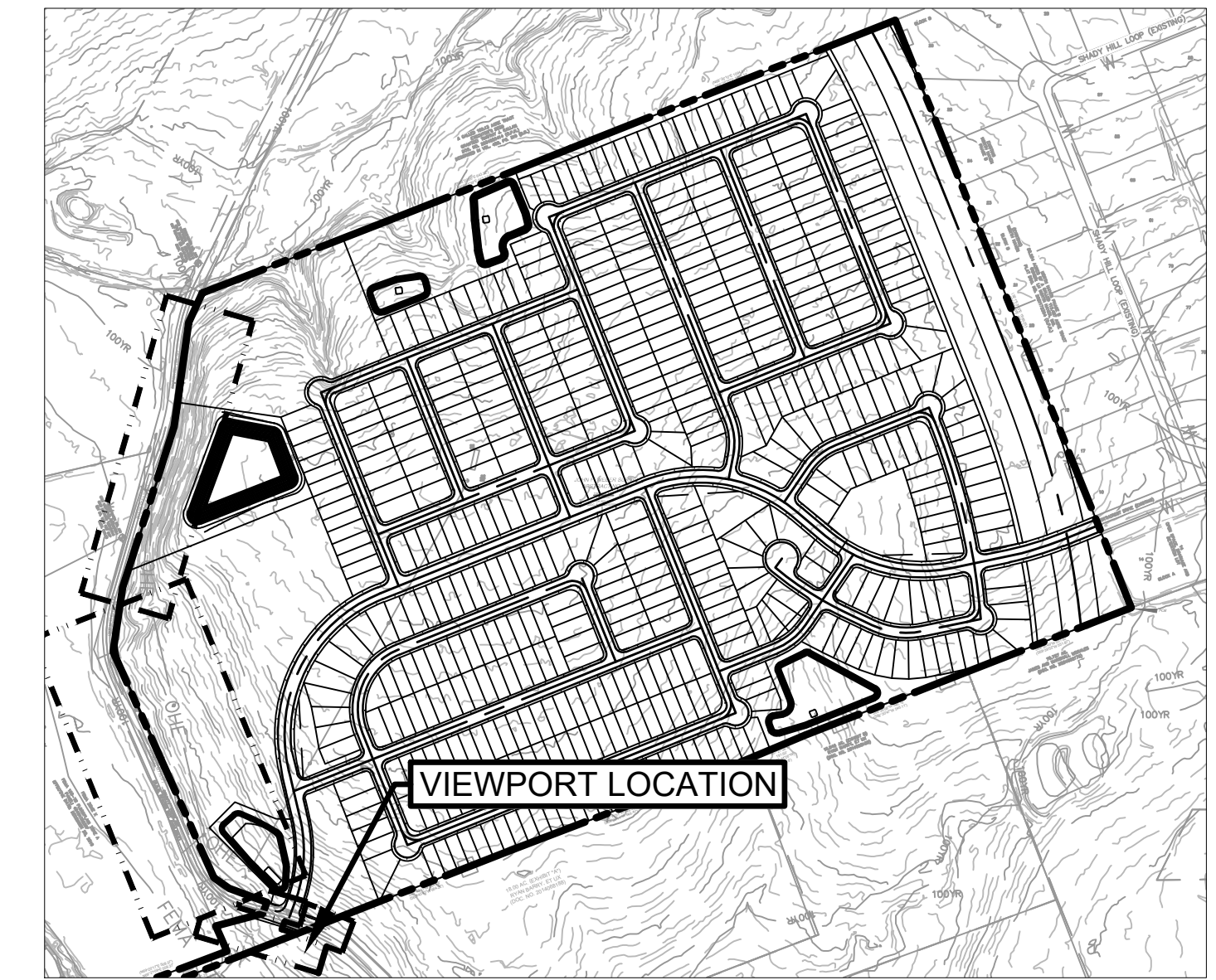
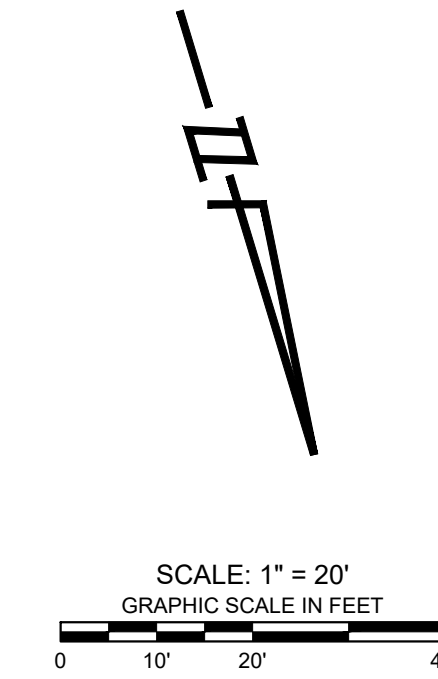
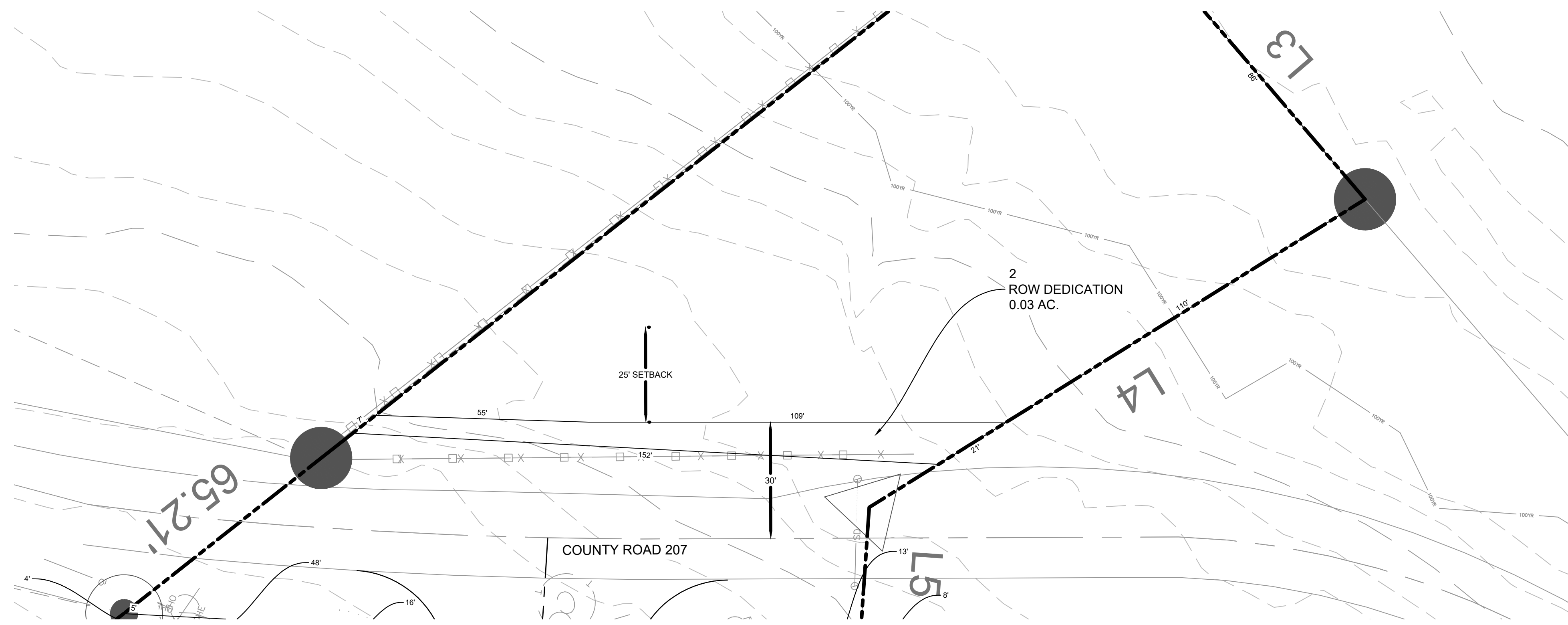

BLOCK A ROW DEDICATION 4 & 5

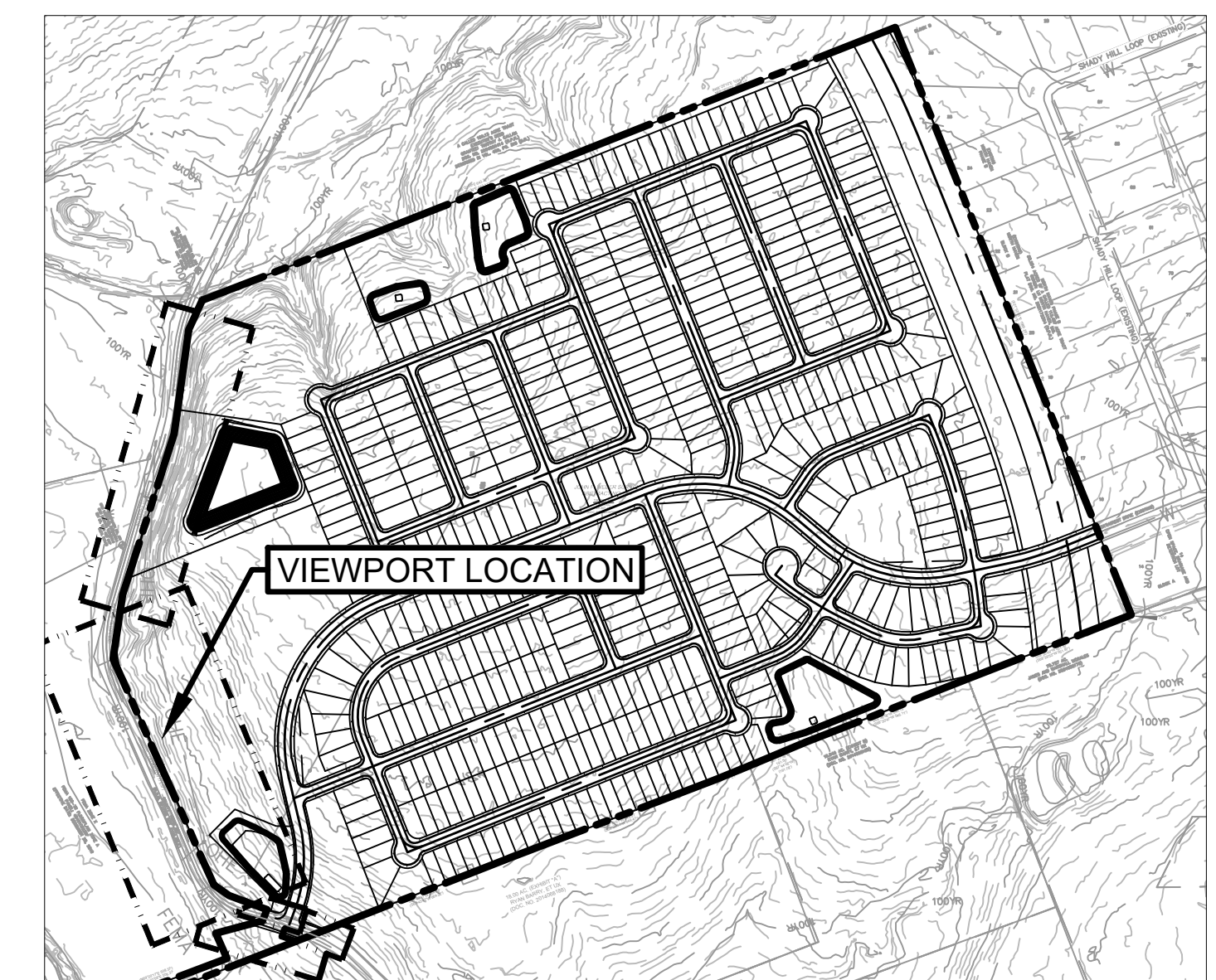
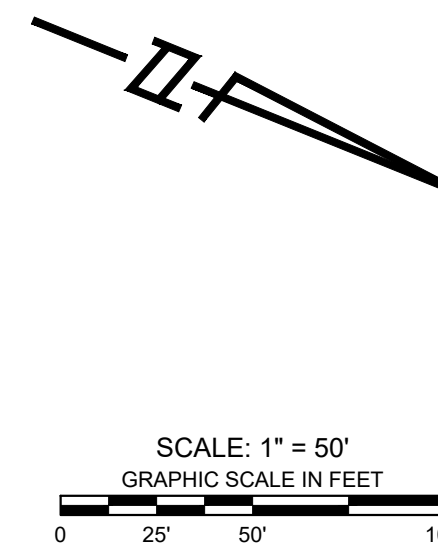
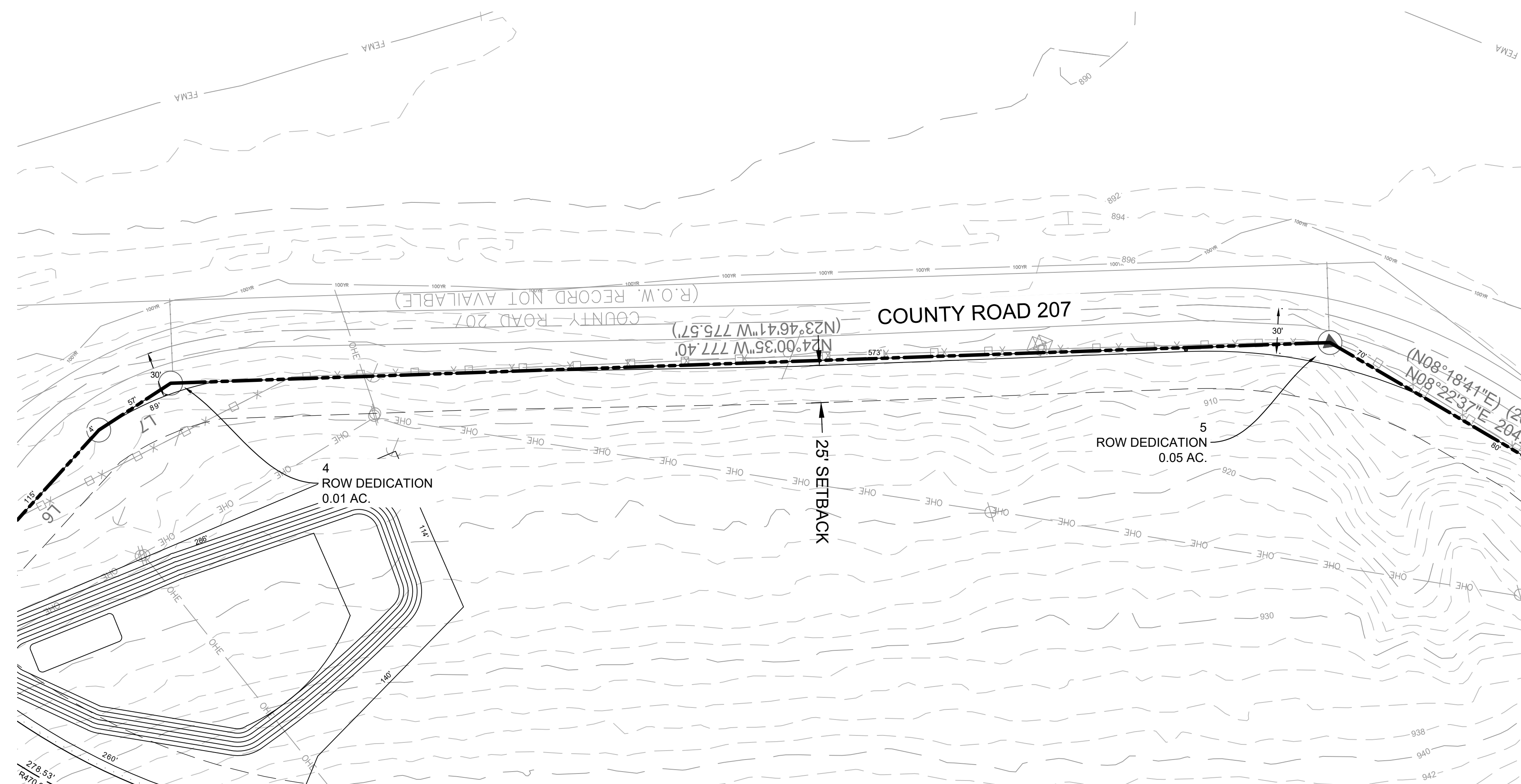

LEGEND

	PROPERTY BOUNDARY
	PHASE BOUNDARY
	PROPOSED STREET CENTERLINE
	PROPOSED LOT LINE
	BUILDING SETBACK
	100-YR F.E.M.A. FLOODPLAIN
	ATLAS 14 100-YR PROPOSED FLOODPLAIN PER STUDY BY WILCO, MAY 2024
	PROPOSED MAILBOX KIOSK
	PROPOSED SIDEWALK
	S.D.E. SIGHT LINE EASEMENT
	ROW DEDICATION LOCATION

8834 N. Capital of Texas Hwy.
Suite 140
Austin, Texas 78759
(512) 452-0371
FAX (512) 454-9933
TBPELS FRM #2946

GRAY
ENGINEERING

NO.	BY	DATE	REVISION DESCRIPTION

**ROW DEDICATION
(SHEET 2 OF 3)**

**RESERVE AT NORTH HAVEN
PRELIMINARY PLAN
WILLIAMSON COUNTY, TX**

PROJECT NO: 11838
DESIGNED BY: XXX
DRAWN BY: XXX
CHECKED BY: XXX

NOTICE:
ALTERATION OF A
SEALED DRAWING
WITHOUT PROPER
NOTIFICATION TO THE
RESPONSIBLE ENGINEER
IS A VIOLATION OF THE
TEXAS ENGINEERING
PRACTICE ACT.

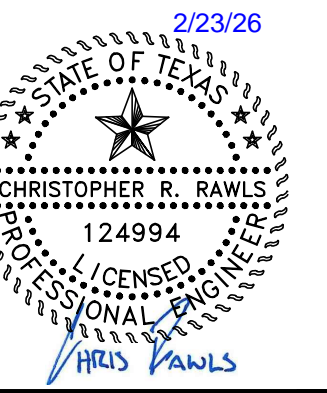

H:\PROJECTS\1737 - PACKSADDLE PARTNERS\1638 PACKSADDLE LIBERTY HILLS\DWG SHEET\1638-C-PREL-COVER.DWG DATE: 2/23/2026 11:02:23 AM BY: GRANMS

ROW DEDICATION 6 & 22

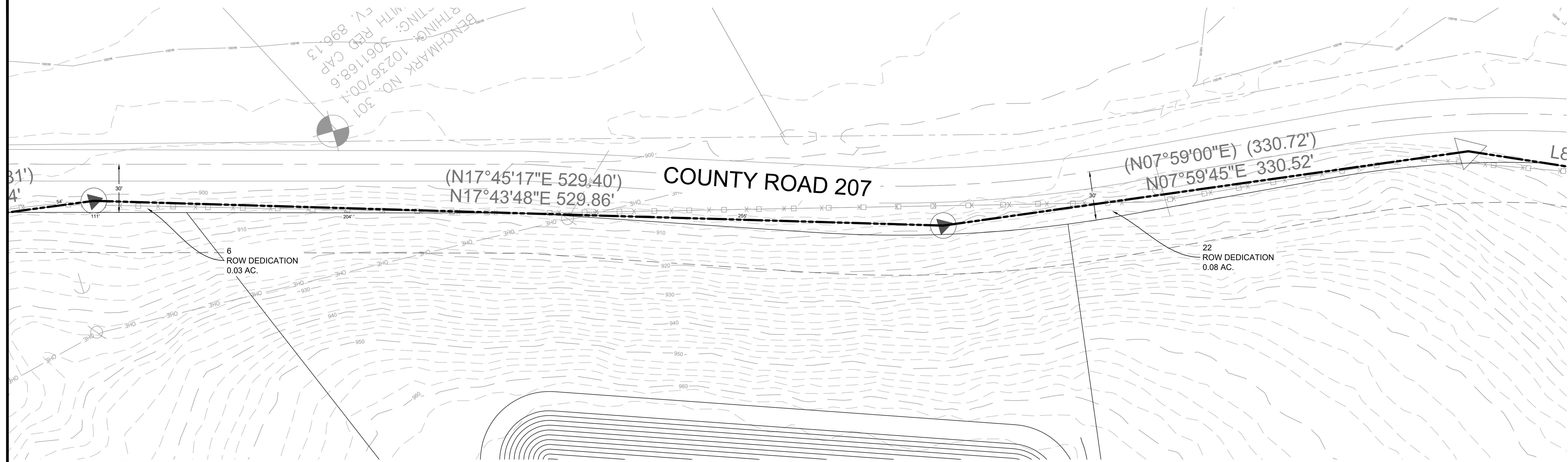

6 ROW DEDICATION
0.03 AC.

22 ROW DEDICATION
0.08 AC.

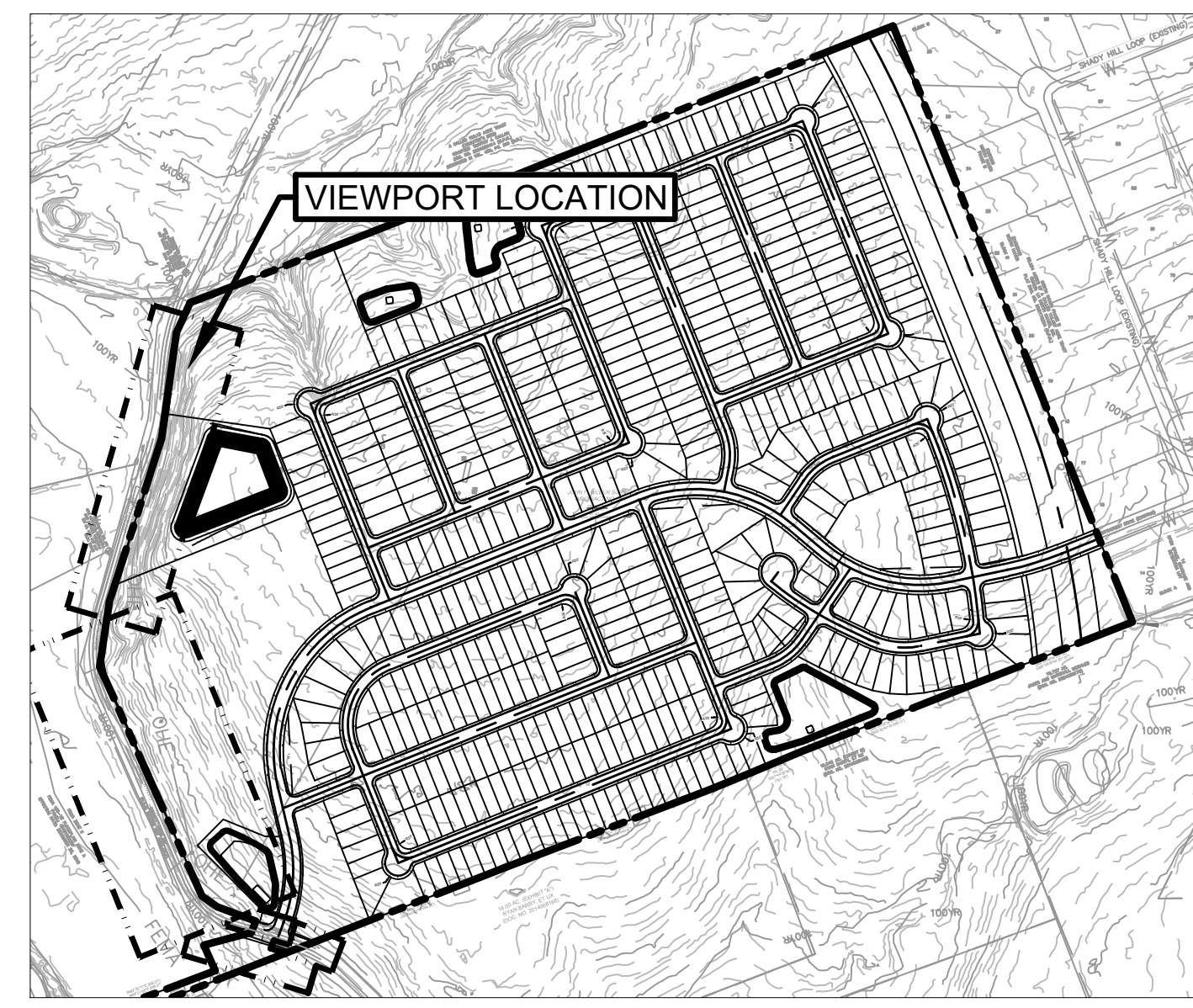
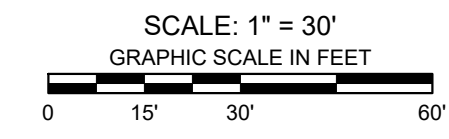
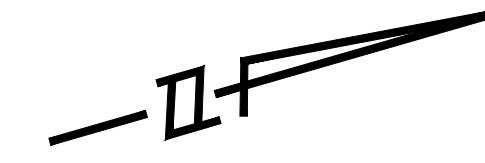

LEGEND	
	PROPERTY BOUNDARY
	SECTION BOUNDARY
	PROPOSED STREET CENTERLINE
	PROPOSED LOT LINE
	BUILDING SETBACK
	100-YR F.E.M.A. FLOODPLAIN
	ATLAS 14 100-YR PROPOSED FLOODPLAIN PER STUDY BY WILCO, MAY 2024
	PROPOSED MAILBOX KIOSK
	PROPOSED SIDEWALK
	SIGHT LINE EASEMENT

8834 N. Capital of Texas Hwy.
Suite 140
Austin, Texas 78759
(512) 452-0371
FAX (512) 454-9933
TBPELS FRM #2946

NO.	BY	DATE	REVISION DESCRIPTION

ROW DEDICATION
(SHEET 3 OF 3)

RESERVE AT NORTH HAVEN
PRELIMINARY PLAN
WILLIAMSON COUNTY, TX

PROJECT NO: 11838
DESIGNED BY: XXX
DRAWN BY: XXX
CHECKED BY: XXX

NOTICE:
ALTERATION OF A
SEALED DRAWING
WITHOUT PROPER
NOTIFICATION TO THE
RESPONSIBLE ENGINEER
IS A VIOLATION OF THE
TEXAS ENGINEERING
PRACTICE ACT.

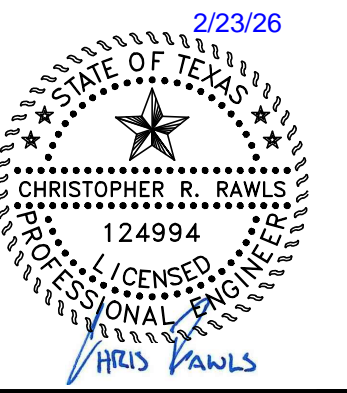

H:\PROJECTS\1737 - PACKSADDLE PARTNERS\11838 - PACKSADDLE LIBERTY HILL\CD\SHEETS\11838-C-PRE-COVER.DWG DATE: 2/23/26 1:20:38 AM BY: GRAMLS

H:\PROJECTS\1737 - PACKSADDLE PARTNERS\1638 PACKSADDLE LIBERTY HILL\CAD\PREL\1638-C-HYDRO-PREL\DWG DATE 2/23/26 11:22:51 AM BY: BSL\MORE

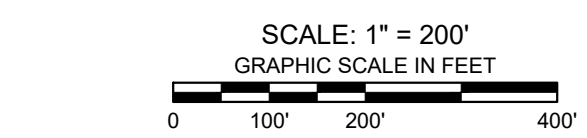

LEGEND

- PROPERTY BOUNDARY
- DRAINAGE AREA BOUNDARY
- TIME OF CONCENTRATION
- 100-YR FEMA FLOODPLAIN ZONE A
- EXISTING MAJOR CONTOUR
- EXISTING MINOR CONTOUR
- FLOW ARROW

Existing Basin Summary

Basin	Area ac	Area sq mi	CN	T _c	Q2	Q10	Q25	Q100
				min	cfs	cfs	cfs	cfs
EX-01	9.47	0.014797	84.00	7.72	23.50	49.90	65.10	88.70
EX-02	10.78	0.016844	84.00	7.46	27.10	57.50	75.00	102.00
EX-03	9.50	0.014844	84.00	10.78	20.40	43.50	56.80	77.30
EX-04	28.18	0.044032	84.00	9.46	64.20	136.50	178.10	242.40
EX-05	13.85	0.021641	84.00	13.32	27.00	57.40	75.00	102.00
EX-06	51.73	0.080829	84.00	14.55	96.50	205.50	268.60	365.40
EX-07	6.60	0.010313	84.00	6.93	17.00	36.20	47.30	64.40
EX-OFF	12.85	0.020079	84.00	9.08	29.80	63.30	82.70	112.70

Existing Output Summary

Analysis Point/Line	Area ac	Area sq mi	Q2	Q10	Q25	Q100
			cfs	cfs	cfs	cfs
EXPOA1	9.47	0.0148	23.5	49.9	65.1	88.70
EXPOA2	10.78	0.01684	27.1	57.5	75	102.00
EXPOA3	9.50	0.01484	20.4	43.5	56.8	77.30
EXLOA4	28.18	0.04403	64.2	136.5	178.1	242.40
EXLOA5	13.85	0.02164	27	57.4	75	102.00
EXPOA6	64.58	0.10091	124.9	266.3	348.1	473.90
EXLOA7	6.60	0.01031	17	36.2	47.3	64.40

8834 N. Capital of Texas Hwy.
Suite 140
Austin, Texas 78759
(512) 452-0371
FAX (512) 454-9933
TBPELS FRM #2946

NO.	BY	DATE	REVISION DESCRIPTION

**EXISTING
HYDROLOGY MAP
(INCLUDING OFSITE)**

**RESERVE AT NORTH HAVEN
PRELIMINARY PLAN
WILLIAMSON COUNTY, TX**

PROJECT NO: 11838
DESIGNED BY: XXX
DRAWN BY: XXX
CHECKED BY: XXX

NOTICE:
ALTERATION OF A
SEALED DRAWING
WITHOUT PROPER
NOTIFICATION TO THE
RESPONSIBLE ENGINEER
IS A VIOLATION OF THE
TEXAS ENGINEERING
PRACTICE ACT.

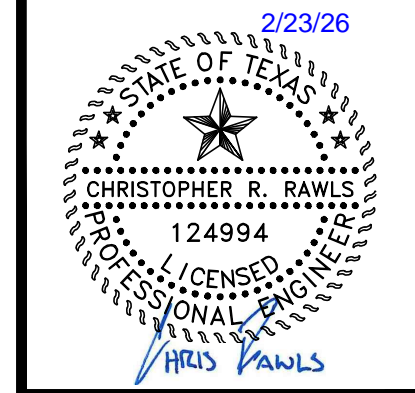

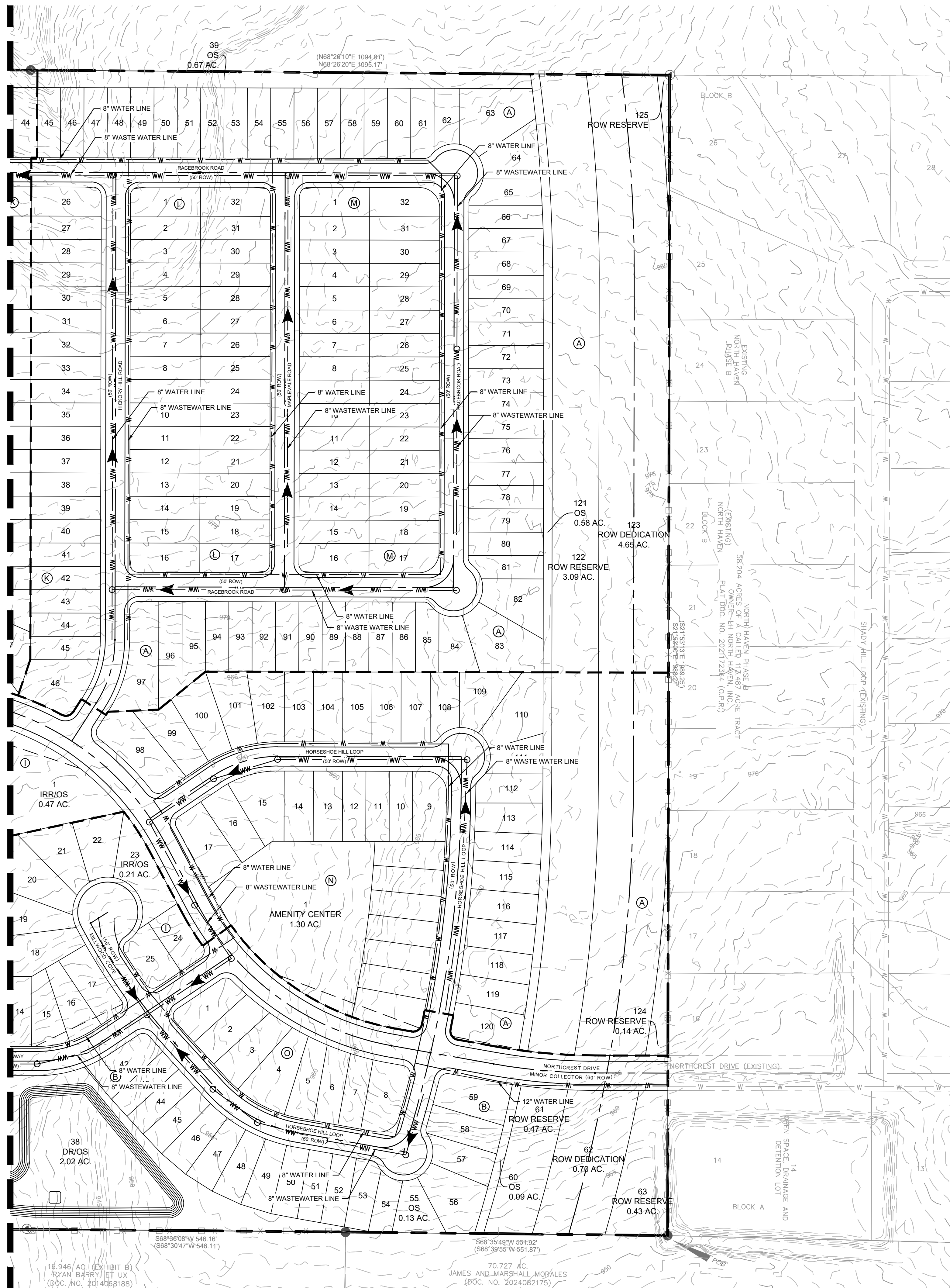

MATCHLINE TO SHEET 12

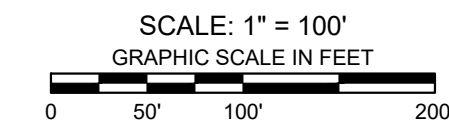
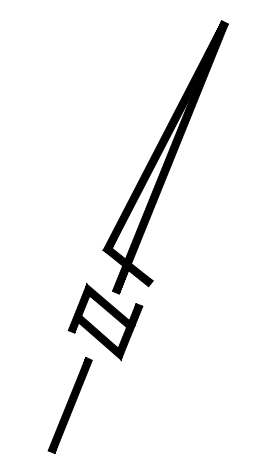

LEGEND	
	PROPERTY BOUNDARY
	PHASE BOUNDARY
	MAJOR ELEV. CONTOUR
	MINOR ELEV. CONTOUR
	PROPOSED WATERLINE
	PROPOSED WASTEWATER LINE
	FORCE MAIN
	TREATED EFFLUENT FORCEMAIN
	PROPOSED MANHOLE
	100-YR F.E.M.A. FLOODPLAIN
	ATLAS 14 100-YR PROPOSED FLOODPLAIN PER STUDY BY WILCO, MAY 2024

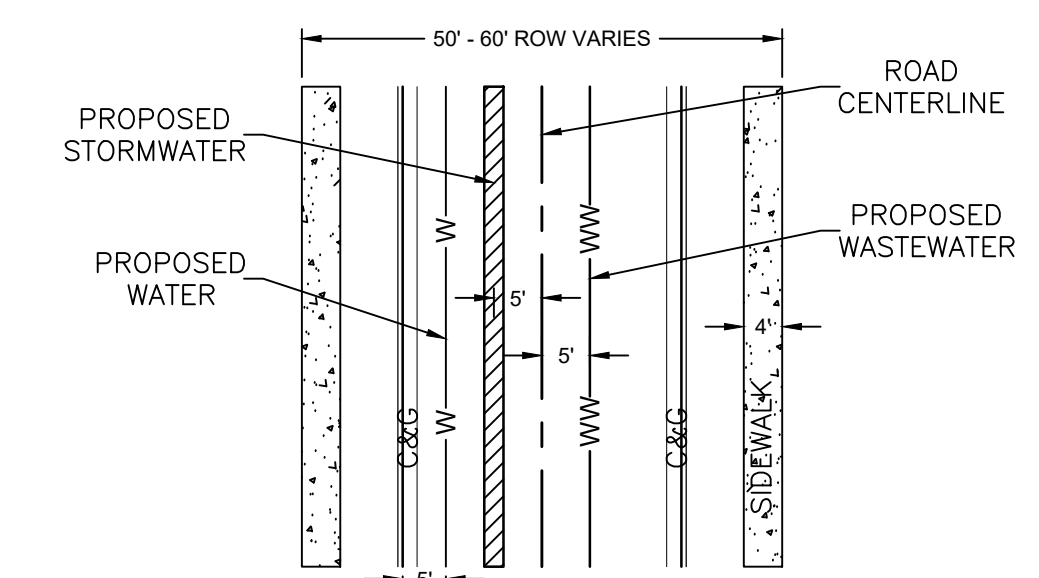

TYPICAL UTILITY ASSIGNMENT DETAIL N.T.S.

8834 N. Capital of Texas Hwy.
Suite 140
Austin, Texas 78759
(512) 452-0371
FAX (512) 454-9933
TBPELS FRM #2946

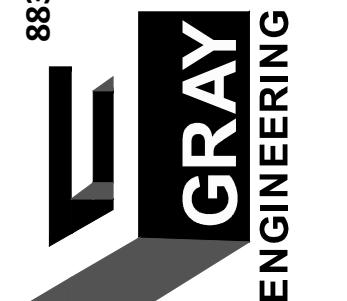

NO.	BY	DATE	REVISION DESCRIPTION

**PROPOSED UTILITIES
(SHEET 2 OF 2)**

**RESERVE AT NORTH HAVEN
PRELIMINARY PLAN
WILLIAMSON COUNTY, TX**

PROJECT NO: 11838
DESIGNED BY: XXX
DRAWN BY: XXX
CHECKED BY: XXX

NOTICE:
ALTERATION OF A
SEALED DRAWING
WITHOUT PROPER
NOTIFICATION TO THE
RESPONSIBLE ENGINEER
IS A VIOLATION OF THE
TEXAS ENGINEERING
PRACTICE ACT.

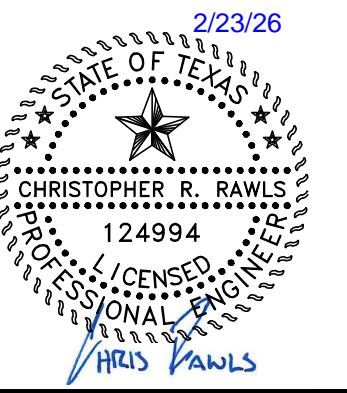

H:\PROJECTS\1237 - PACKSADDLE PARTNERS\11838 - PACKSADDLE LIBERTY HILL CAD SHEETS\11838-C-PREL-UTIL.DWG DATE: 2/23/2025 1:26:15 AM BY: T.MARSHALL

Commissioners Court - Regular Session

20.

Meeting Date: 03/10/2026

Replat of Lots 20-22 Sec 3 Lost River Ranches Subdivision – Pct 3

Submitted For: Adam Boatright

Submitted By: Misti Schulz, Infrastructure

Department: Infrastructure

Agenda Category: Consent

Information

Agenda Item

Discuss, consider, and take appropriate action on approval of the Replat of Lots 20-22 Section 3, Lost River Ranches Subdivision – Precinct 3.

Public Background

This replat consists of 8 residential lots and no new roads. The purpose of this replat is to subdivide the existing lots 20, 21, and 22 into 8 new lots. Drainage construction is not yet complete, but a financial security in the amount of \$47,690.50 has been posted with the County to cover the cost of the remaining construction.

Timeline

- 2026-01-06 – initial submittal of the replat
- 2026-02-05 – 1st review complete with comments
- 2026-02-11 – 2nd submittal of replat
- 2026-02-20 – 2nd review complete with comments
- 2026-03-02 – 3rd submittal of replat
- 2026-03-03 – 3rd review complete with comments cleared
- 2026-03-03 – receipt of replat with signatures
- 2026-03-03 – replat placed on the March 10th, 2026, Commissioners Court agenda for consideration

Fiscal Impact

From/To	Acct No.	Description	Amount
---------	----------	-------------	--------

Attachments

Replat - Lost River Ranches Sec 3 Lots 20-22

Form Review

Inbox

County Judge Exec Asst.
 Form Started By: Misti Schulz
 Final Approval Date: 03/04/2026

Reviewed By

Delia Colon

Date

03/04/2026 08:31 AM
 Started On: 03/03/2026 01:41 PM

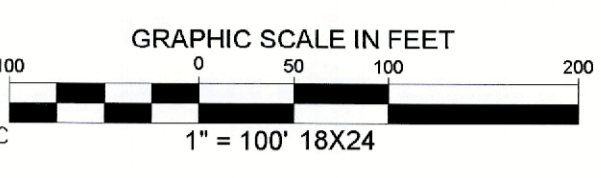
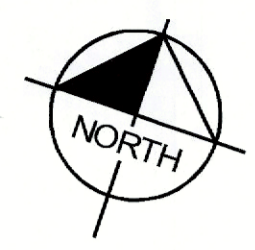
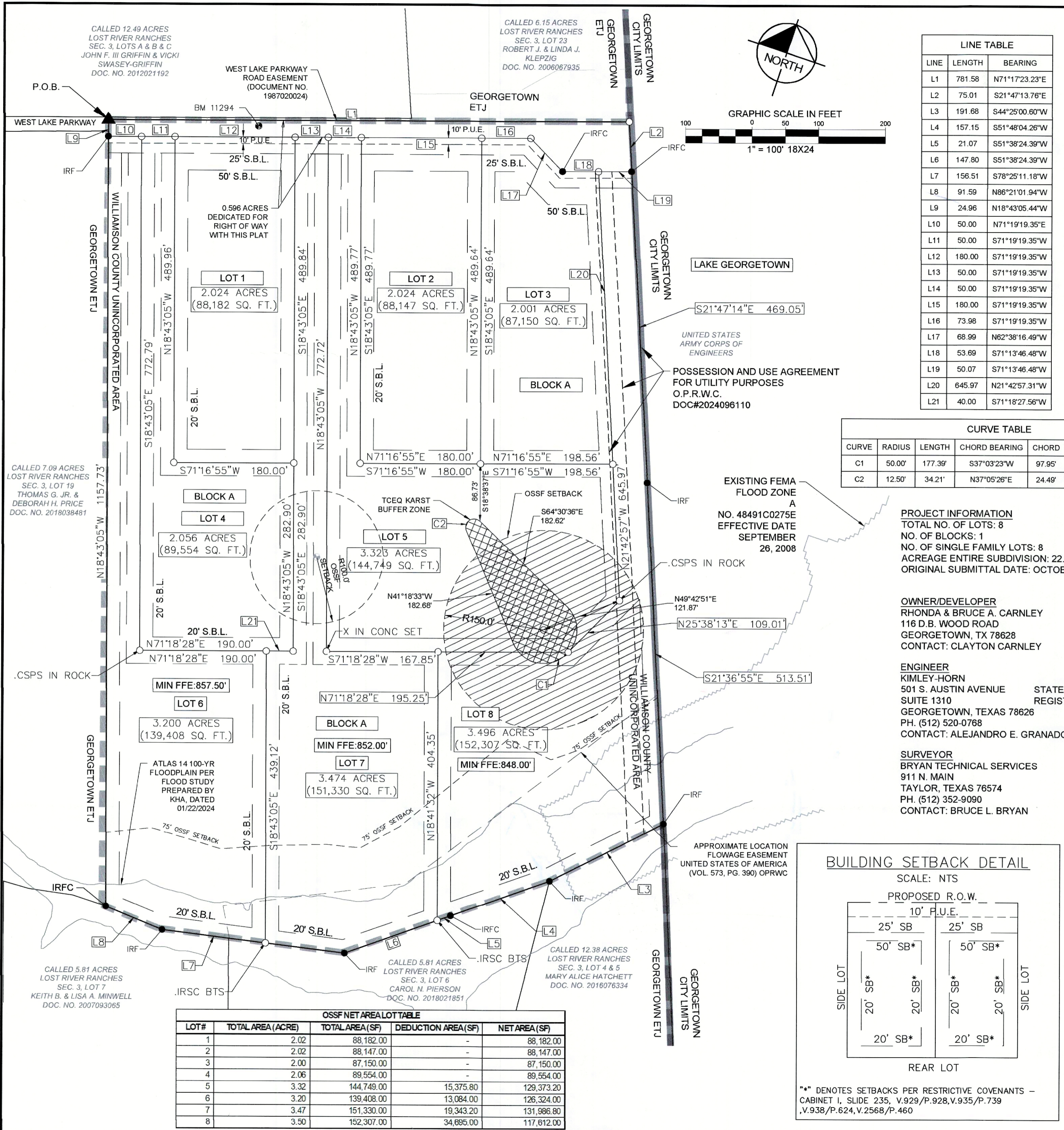

LINE TABLE		
LINE	LENGTH	BEARING
L1	781.58	N71°17'23.23"E
L2	75.01	S21°47'13.76"E
L3	191.68	S44°25'00.60"W
L4	157.15	S51°48'04.26"W
L5	21.07	S51°38'24.39"W
L6	147.80	S51°38'24.39"W
L7	156.51	S78°25'11.18"W
L8	91.59	N86°21'01.94"W
L9	24.96	N18°43'05.44"W
L10	50.00	N71°19'19.35"E
L11	50.00	S71°19'19.35"W
L12	180.00	S71°19'19.35"W
L13	50.00	S71°19'19.35"W
L14	50.00	S71°19'19.35"W
L15	180.00	S71°19'19.35"W
L16	73.98	S71°19'19.35"W
L17	68.99	N62°38'16.49"W
L18	53.69	S71°13'46.48"W
L19	50.07	S71°13'46.48"W
L20	645.97	N21°42'57.31"W
L21	40.00	S71°18'27.56"W

CURVE TABLE						
CURVE	RADIUS	LENGTH	CHORD BEARING	CHORD	DELTA	TANGENT
C1	50.00'	177.39'	S37°03'23"W	97.95'	203°16'13"	242.82'
C2	12.50'	34.21'	N37°05'26"E	24.49'	156°47'57"	60.89'

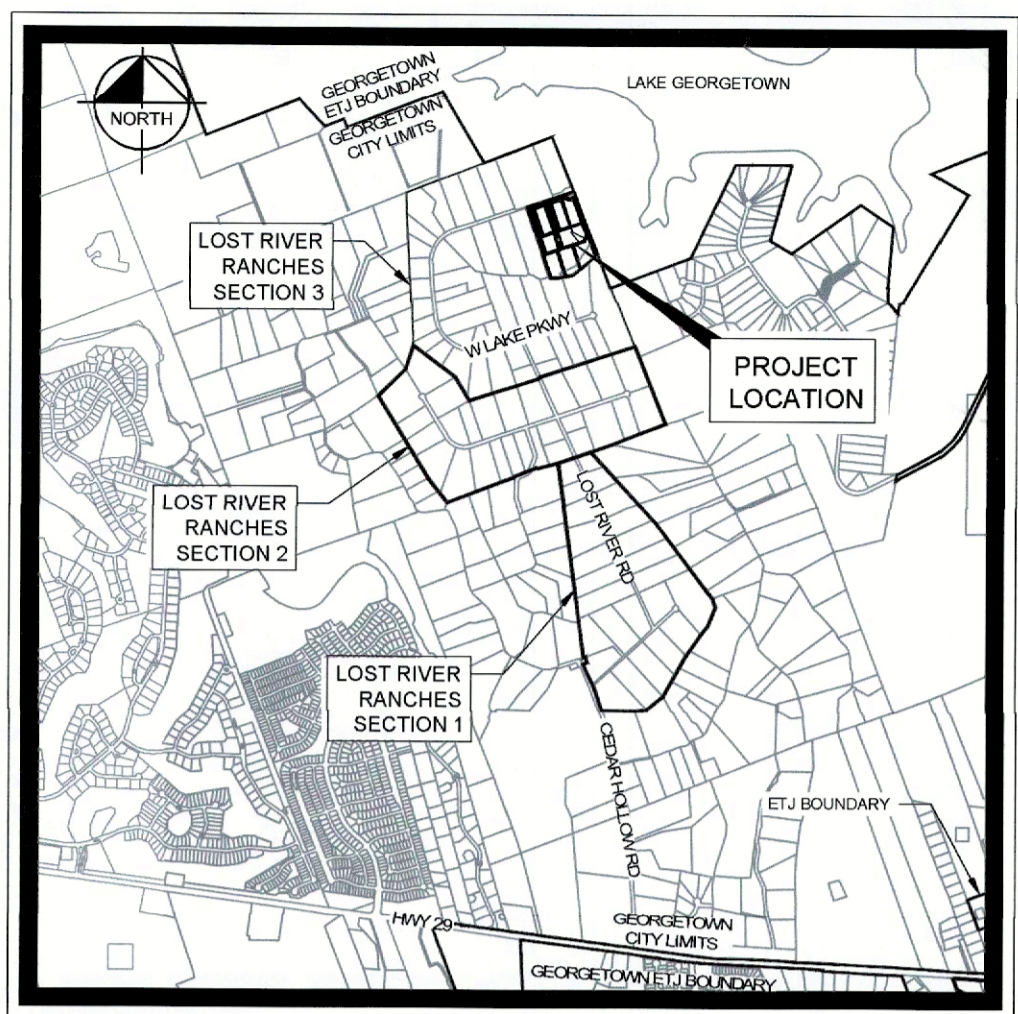

VICINITY MAP
SCALE: 1" = 3,000'

BENCHMARKS:
 BM-11294: COTTON GEAR SPINDLE SET, APPROXIMATELY 0.7 FEET NORTH OF THE EDGE OF ASPHALT OF WEST LAKE PARKWAY, AND APPROXIMATELY 8.5 FEET SOUTH OF THE PROPOSED CENTERLINE OF WEST LAKE PARKWAY.
 NORTHING: 10215008.644
 EASTING: 3102719.586
 ELEV: 952.227

PROJECT INFORMATION
 TOTAL NO. OF LOTS: 8
 NO. OF BLOCKS: 1
 NO. OF SINGLE FAMILY LOTS: 8
 ACREAGE ENTIRE SUBDIVISION: 22.19
 ORIGINAL SUBMITTAL DATE: OCTOBER 24TH 2025

OWNER/DEVELOPER
 RHONDA & BRUCE A. CARNLEY
 116 D.B. WOOD ROAD
 GEORGETOWN, TX 78628
 CONTACT: CLAYTON CARNLEY

ENGINEER
 KIMLEY-HORN
 501 S. AUSTIN AVENUE STATE OF TEXAS
 SUITE 1310 REGISTRATION NO. F-928
 GEORGETOWN, TEXAS 78626
 PH. (512) 520-0768
 CONTACT: ALEJANDRO E. GRANADOS RICO

SURVEYOR
 BRYAN TECHNICAL SERVICES
 911 N. MAIN
 TAYLOR, TEXAS 76754
 PH. (512) 352-9090
 CONTACT: BRUCE L. BRYAN

LEGEND	
●	O.P.R.W.C.
○	P.O.B.
●	P.O.C.
●	IRFC
○	IRF
○	CSPS
▲	OFFICIAL PUBLIC RECORDS WILLIAMSON COUNTY
▲	POINT OF BEGINNING
▲	POINT OF COMMENCEMENT
●	IRON ROD FOUND WITH CAP
○	IRON ROD FOUND
○	IRON ROD WITH CAP "BTS" SET
○	COTTON GEAR SPINDLE SET IN ROCK
▲	CALCULATED POINT
—	EXISTING WATER WALL
—	BOUNDARY LINE
---	PROPOSED LOT LINE
---	EASEMENT
---	ATLAS 14 100-YR FLOODPLAIN PER FLOOD STUDY PREPARED BY KHA, DATED 01/22/2024
---	EXISTING FEMA FLOOD ZONE A
---	BUILDING SETBACK
---	GEORGETOWN ETJ LIMITS
---	GEORGETOWN CITY LIMITS
---	BOUNDARY
---	TCEQ KARSTS BUFFER ZONE
---	OSSF BUFFER ZONE

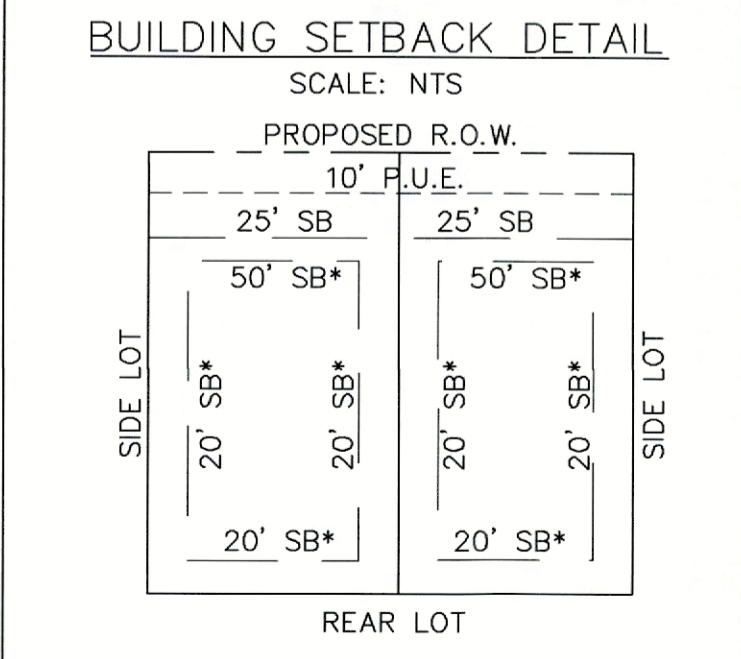

"*" DENOTES SETBACKS PER RESTRICTIVE COVENANTS - CABINET I, SLIDE 235, V.929/P.928, V.935/P.739, V.938/P.624, V.2568/P.460

OSSF NET AREA LOT TABLE				
LOT#	TOTAL AREA (ACRE)	TOTAL AREA (SF)	DEDUCTION AREA (SF)	NET AREA (SF)
1	2.02	88,182.00	-	88,182.00
2	2.02	88,147.00	-	88,147.00
3	2.00	87,150.00	-	87,150.00
4	2.06	89,554.00	-	89,554.00
5	3.32	144,749.00	15,375.80	129,373.20
6	3.20	139,408.00	13,084.00	126,324.00
7	3.47	151,330.00	19,343.20	131,986.80
8	3.50	152,307.00	34,695.00	117,612.00

REPLAT OF LOT 20, 21, AND 22 SECTION 3 LOST RIVER RANCHES
 BEING 22.19 ACRE SUBDIVISION SITUATED IN THE A. H. PORTER SURVEY, ABSTRACT 490 WILLIAMSON COUNTY, TEXAS



501 S. AUSTIN AVENUE, SUITE 1310 STATE OF TEXAS TEL. NO. (512) 520-0768
 GEORGETOWN, TEXAS 78626 REGISTRATION # F-928 WWW.KIMLEY-HORN.COM

SCALE	DRAWN BY	CHECKED BY	DATE	PROJECT NO.	SHEET NO.
1" = 100'	AEG	AEG	02/26/2026	069412700	1 OF 2

DWG NAME: K:\GEO_CIVIL\069412700 - LOST RIVER RANCHES\CAD\PRELIMINARY\PLANS\REPLAT OF LOT 20, 21, AND 22 SECTION 3 LOST RIVER RANCHES.DWG PLOTTED BY: GRANADOS, ALEX 2/26/2026 4:33 PM LAST SAVED: 2/26/2026 3:31 PM

LEGAL DESCRIPTION:

DESCRIPTION OF A 22.19 ACRE TRACT OF LAND LOCATED IN THE A.H. PORTER SURVEY, ABSTRACT 490, WILLIAMSON COUNTY, TEXAS, BEING ALL OF LOTS 20, 21, AND 22, LOST RIVER RANCHES SECTION 3 SUBDIVISION, RECORDED IN CABINET I, SLIDE 235, RECORDED AS DOCUMENT NO. 1987020024, OF THE PLAT RECORDS OF WILLIAMSON COUNTY, TEXAS. SAID 22.19 ACRE TRACT OF LAND BEING MORE PARTICULARLY DESCRIBED BY METES AND BOUNDS AS FOLLOWS:

BEGINNING AT A CALCULATED CORNER IN THE CENTER OF WEST LAKE PARKWAY, SAME BEING THE NORTHWEST CORNER OF SAID "LOT 20" AND THE NORTHEAST CORNER OF A CALLED "LOT 19, SECTION 3 OF LOST RIVER RANCHES, SECTION ONE, TWO, AND THREE", A SUBDIVISION IN WILLIAMSON COUNTY, RECORDED IN CABINET I, SLIDE 235, PLAT RECORDS OF WILLIAMSON COUNTY, SAME BEING THE NORTHEAST CORNER OF SUBJECT TRACT:

THENCE NORTH 71° 17' 23" EAST, ALONG THE CENTER LINE OF WEST LAKE PARKWAY AND THE NORTH LINE OF SAID "LOTS 20, 21, 22", AT 259.81 FEET A FOUND 1/2" IRON ROD FOUND (CAPPED TLS) LIES 24.92 FEET RIGHT (AS MEASURED IN A PERPENDICULAR FASHION), AT 518.36 FEET A FOUND 1/2" IRON ROD FOUND LIES 25.32 FEET RIGHT (AS MEASURED IN A PERPENDICULAR FASHION), AT 633.99 FEET A FOUND 1/2" IRON ROD FOUND LIES 25.32 FEET RIGHT (AS MEASURED IN A PERPENDICULAR FASHION), AT 681.85 FEET A FOUND 1/2" IRON ROD FOUND (CAPPED TLS) LIES 75.00 FEET RIGHT (AS MEASURED IN A PERPENDICULAR FASHION) AND CONTINUING AN ADDITIONAL 99.73 FEET FOR A TOTAL DISTANCE OF 781.58 FEET, TO A CALCULATED CORNER BEING THE NORTHEAST CORNER OF SAID "LOT 22" AND AN EXTERIOR CORNER OF A TRACT CONVEYED TO THE UNITED STATES OF AMERICA CORPS OF ENGINEERS (PER WCAD), ALSO BEING THE NORTHEAST CORNER OF SUBJECT TRACT;

THENCE SOUTH 21° 47' 14" EAST, ALONG AN EXTERIOR LINE OF SAID UNITED STATES OF AMERICA CORPS OF ENGINEERS TRACT AND THE EAST LINE OF SAID "LOT 22", PASSING A 1/2" IRON ROD FOUND (CAPPED TLS) AT A DISTANCE OF 75.00 FEET, CONTINUING FOR A TOTAL DISTANCE OF 544.06 FEET, TO A 1/2" IRON ROD FOUND IN AN EXTERIOR LINE OF A SAID UNITED STATES OF AMERICA CORPS OF ENGINEERS TRACT AND THE EAST LINE OF SAID "TRACT 22", BEING AN EXTERIOR CORNER OF BOTH SAID "LOT 22" AND SAID UNITED STATES OF AMERICA CORPS OF ENGINEERS TRACT, ALSO BEING AN EXTERIOR CORNER OF SUBJECT TRACT;

THENCE SOUTH 21° 36' 55" EAST, ALONG AN EXTERIOR LINE OF SAID UNITED STATES OF AMERICA CORPS OF ENGINEERS TRACT AND THE EAST LINE OF SAID "LOT 22", A DISTANCE OF 513.51 FEET, TO A 1/2" IRON ROD FOUND, BEING THE SOUTHWEST CORNER OF SAID "LOT 22", AN EXTERIOR CORNER SAID UNITED STATES OF AMERICA CORPS OF ENGINEERS TRACT, SAME BEING THE NORTHEAST CORNER OF A CALLED "LOT 5, SECTION 3 OF LOST RIVER RANCHES, SECTION ONE, TWO, AND THREE", A SUBDIVISION IN WILLIAMSON COUNTY, RECORDED IN CABINET I, SLIDE 235, PLAT RECORDS OF WILLIAMSON COUNTY, ALSO BEING THE SOUTHWEST CORNER OF SUBJECT TRACT;

THENCE SOUTH 44° 25' 01" WEST, ALONG A SOUTHERN LINE OF SAID "LOT 22" AND THE NORTH LINE OF SAID "LOT 5", A DISTANCE OF 191.68 FEET, TO A 1/2" IRON ROD FOUND BEING THE SOUTHWEST CORNER OF SAID "LOT 22" AND THE NORTHWEST CORNER OF SAID "LOT 5", SAME BEING THE NORTHEAST CORNER OF A CALLED "LOT 6, SECTION 3 OF LOST RIVER RANCHES, SECTION ONE, TWO, AND THREE", A SUBDIVISION IN WILLIAMSON COUNTY, RECORDED IN CABINET I, SLIDE 235, PLAT RECORDS OF WILLIAMSON COUNTY", ALSO BEING AN EXTERIOR CORNER OF SUBJECT TRACT;

THENCE SOUTH 51° 48' 04" WEST, ALONG A SOUTHERN LINE OF "LOT 22" AND A NORTHERN LINE OF SAID "LOT 6", A DISTANCE OF 157.15 FEET, TO A 1/2" IRON ROD FOUND (CAPPED TLS) BEING THE SOUTHWEST CORNER OF SAID "LOT 22" AND THE SOUTHWEST CORNER OF SAID "LOT 21" AND AN EXTERIOR CORNER OF SAID "LOT 6", SAME BEING AN EXTERIOR CORNER OF SUBJECT TRACT;

THENCE SOUTH 51° 38' 24" WEST, ALONG A SOUTHERN LINE OF "LOT 21" AND A NORTHERN LINE OF SAID "LOT 6", A DISTANCE OF 168.87 FEET, TO A 1/2" IRON ROD FOUND BEING AN EXTERIOR CORNER OF SAID "LOT 21" AND SAID "LOT 6", SAME BEING AN EXTERIOR CORNER OF SUBJECT TRACT;

THENCE SOUTH 78° 31' 52" WEST, ALONG A SOUTHERN LINE OF "LOT 21" AND A NORTHERN LINE OF SAID "LOT 6", A DISTANCE OF 100.08 FEET, TO A 1/2" IRON ROD FOUND BEING THE SOUTHWEST CORNER OF SAID "LOT 20" AND THE SOUTHWEST CORNER OF SAID "LOT 21", SAME BEING AN EXTERIOR CORNER OF SAID "LOT 6" AND AN EXTERIOR CORNER OF SUBJECT TRACT;

THENCE SOUTH 78° 25' 11" WEST, ALONG A SOUTHERN LINE OF "LOT 20" AND A NORTHERN LINE OF SAID "LOT 6", PASSING THE NORTHWEST CORNER OF SAID "LOT 6" SAME BEING THE NORTHEAST FROM A CALLED "LOT 7, SECTION 3 OF LOST RIVER RANCHES, SECTION ONE, TWO, AND THREE", A SUBDIVISION IN WILLIAMSON COUNTY, RECORDED IN CABINET I, SLIDE 235, PLAT RECORDS OF WILLIAMSON COUNTY, AT A DISTANCE OF 68.92 FEET, CROSSING ONTO A NORTHERN LINE OF SAID "LOT 7" CONTINUING FOR A TOTAL DISTANCE OF 175.85 FEET, TO A 1/2" IRON ROD FOUND BEING AN EXTERIOR CORNER OF SAID "LOT 20" AND SAID "LOT 7", SAME BEING AN EXTERIOR CORNER OF SUBJECT TRACT;

THENCE NORTH 86° 21' 02" WEST, ALONG A SOUTHERN LINE OF "LOT 20" AND A NORTHERN LINE OF SAID "LOT 6", A DISTANCE OF 91.59 FEET, TO A 1/2" IRON ROD FOUND BEING THE SOUTHWEST CORNER OF SAID "LOT 20" AND THE SOUTHWEST CORNER OF SAID "LOT 19", SAME BEING AN EXTERIOR CORNER OF SAID "LOT 7" AND THE SOUTHWEST CORNER OF SUBJECT TRACT;

THENCE NORTH 18° 43' 05" WEST, ALONG THE EAST LINE OF SAID "LOT 19" AND THE WEST LINE OF SAID "LOT 21", PASSING A 1/2" IRON ROD FOUND AT A DISTANCE OF 1157.69 FEET, CONTINUING FOR A TOTAL DISTANCE OF 1182.69 FEET, TO THE POINT OF BEGINNING, CONTAINING ACCORDING TO THE DIMENSIONS HEREIN STATED, AN AREA OF 22.19 ACRES.

WATERSHED STATUS

THIS SITE IS LOCATED IN THE NORTH FORK OF THE SAN GABRIEL RIVER WATERSHED. THIS SITE IS LOCATED IN THE EDWARDS AQUIFER RECHARGE ZONE AND THE EDWARDS AQUIFER CONTRIBUTING ZONE.

FLOODPLAIN INFORMATION

LOTS WITHIN THIS SUBDIVISION ARE ENCLOSED BY A SPECIAL FLOOD HAZARD AREA INDICATED BY THE 100 YEAR FLOOD AS IDENTIFIED BY THE U.S. FEDERAL EMERGENCY MANAGEMENT AGENCY BOUNDARY MAP #48491C0275E FOR WILLIAMSON COUNTY, EFFECTIVE DATE SEPTEMBER 26, 2008.

C10 - DEVELOPMENT NOTES:

C10.1 DRAINAGE MAINTENANCE MAINTENANCE RESPONSIBILITY FOR DRAINAGE WILL NOT BE ACCEPTED BY THE COUNTY OTHER THAN THAT ACCEPTED IN CONNECTION WITH DRAINING OR PROTECTING THE ROAD SYSTEM. MAINTENANCE RESPONSIBILITY FOR STORM WATER MANAGEMENT CONTROLS WILL REMAIN WITH THE OWNER.

C10.2 UTILITY SERVICE PROVIDERS: WATER SERVICE IS PROVIDED BY: CITY OF GEORGETOWN WASTEWATER SERVICE IS PROVIDED BY: ON-SITE SEWAGE FACILITY

C10.3 IMPROVEMENTS WITHIN THE RIGHT-OF-WAY OR ROAD WIDENING EASEMENTS THE LANDOWNER ASSUMES ALL RISKS ASSOCIATED WITH IMPROVEMENTS LOCATED IN THE RIGHT-OF-WAY OR ROAD WIDENING EASEMENTS. BY PLACING ANYTHING IN THE RIGHT-OF-WAY OR ROAD WIDENING EASEMENTS, THE LANDOWNER INDEMNIFIES AND HOLDS THE COUNTY, ITS OFFICERS AND EMPLOYEES HARMLESS FROM ANY LIABILITY OWING TO PROPERTY DEFECTS OR NEGLIGENCE NOT ATTRIBUTABLE TO THEM AND ACKNOWLEDGES THAT THE IMPROVEMENTS MAY BE REMOVED BY THE COUNTY AND THAT THE OWNER OF THE IMPROVEMENT SHALL BE RESPONSIBLE FOR THE RELOCATION AND/OR REPLACEMENT OF THE IMPROVEMENT.

C10.4 RURAL MAILBOXES RURAL MAILBOXES SHALL BE SET THREE FEET FROM THE EDGE OF THE PAVEMENT OR BEHIND CURBS, WHEN USED. ALL MAILBOXES WITHIN COUNTY ARTERIAL RIGHT-OF-WAY HALL MEET THE CURRENT TXDOT STANDARDS. ANY MAILBOX THAT DOES NOT MEET THIS REQUIREMENT MAY BE REMOVED BY WILLIAMSON COUNTY.

C10.5 REPLATS EXCEPT AS MAY BE MODIFIED OF HEREON, THIS REPLAT IS SUBJECT TO ALL APPLICABLE PLAT NOTES AND RESTRICTIONS AS SET FORTH IN THE ORIGINAL PLAT OF 20, 21, AND 22 OF SECTION 3, RECORDED IN CABINET I, SLIDE 235, RECORDED AS DOCUMENT NO. 1987020024 IN THE OFFICIAL PUBLIC RECORDS OF WILLIAMSON COUNTY.

C10.6 SIGHT DISTANCE EASEMENTS NO CONSTRUCTION, PLANTING OR GRADING SHALL BE PERMITTED TO INTERFERE WITH SIGHT DISTANCE EASEMENTS BETWEEN THE HEIGHTS OF THREE AND EIGHT FEET AS MEASURED FROM THE CROWNS OF THE ADJACENT STREETS.

C10.7 SIDEWALK MAINTENANCE ALL SIDEWALKS WITHIN THIS SUBDIVISION ARE TO BE MAINTAINED BY EACH OF THE ADJACENT PROPERTY OWNERS.

C10.8 IMPERVIOUS COVER MAXIMUM OF 20% IMPERVIOUS COVER PER LOT, OTHERWISE STORMWATER MANAGEMENT CONTROLS SHALL BE DESIGNED, CONSTRUCTED AND MAINTAINED BY IF IMPERVIOUS COVER IS PROPOSED TO EXCEED MAXIMUM PERCENTAGE ALLOWED, CONTACT WILLIAMSON COUNTY FLOODPLAIN ADMINISTRATION TO REVIEW THE STORMWATER MANAGEMENT CONTROLS PROPOSED ON LOT.

C10.9 MINIMUM FINISHED FLOOR ELEVATION THE MINIMUM FFE SHALL BE AT LEAST ONE FOOT ABOVE THE ADJACENT FINISHED GRADE AND BFE. EXCEPTIONS CAN BE MADE AT ENTRANCE AND EGRESS POINTS, WHERE NECESSARY, TO MEET THE AMERICANS WITH DISABILITIES ACT (ADA). RECREATIONAL VEHICLE PARKING PADS MUST ALSO BE PLACED AT LEAST ONE FOOT ABOVE BFE.

C10.11 NATURAL DRAINAGE PATTERN/SHEET FLOW SUBDIVISIONS THIS SUBDIVISION IS DESIGNED TO ALLOW NATURAL DRAINAGE PATTERNS TO SHEET FLOW ACROSS PROPERTIES AND ROADWAYS. PROPERTY GRADING SHALL DIRECT WATER AWAY FROM THE STRUCTURAL FOUNDATION, INCLUDING STORMWATER THAT ORIGINATES ACROSS ROADWAYS. IT IS THE PROPERTY OWNERS RESPONSIBILITY TO ENSURE THAT TOP OF GRASS OR OTHER LANDSCAPING ALONG RIBBON CURB, ON THE DOWNSLOPE SIDE OF THE ROADWAY, DOES NOT OBSTRUCT OR REDIRECT FLOW WITHIN THE RIGHT-OF-WAY. THIS REQUIREMENT APPLIES TO BLOCK A LOTS 1-8.

C10.12 DRIVEWAY MAINTENANCE DRIVEWAY MAINTENANCE WILL BE THE RESPONSIBILITY OF THE PROPERTY OWNER. IF OBSTRUCTIONS OCCUR WITHIN THE DRIVEWAY CULVERT, THE COUNTY RESERVES THE RIGHT TO CLEAR OBSTRUCTIONS THAT ARE CAUSING ADVERSE IMPACTS TO THE ROADWAY.

C11 - FLOODPLAIN NOTES

C11.1 FLOOD HAZARD AREA LOTS 4 AND 5 ARE ENCLOSED BY A SPECIAL FLOOD HAZARD AREA(S) UNINUNDATED BY THE 100-YEAR (1% CHANCE) FLOOD AS IDENTIFIED BY THE U.S. FEDERAL EMERGENCY MANAGEMENT AGENCY FLOOD INSURANCE RATE MAP, COMMUNITY PANEL NO. #48491C0275E, EFFECTIVE DATE SEPTEMBER, 2008 FOR WILLIAMSON COUNTY, TEXAS.

C11.2 NO STRUCTURE OR LAND IN THIS PLAT SHALL HEREAFTER BE LOCATED OR ALTERED WITHOUT FIRST OBTAINING A CERTIFICATE OF COMPLIANCE OR FLOODPLAIN DEVELOPMENT PERMIT FROM THE WILLIAMSON COUNTY FLOODPLAIN ADMINISTRATOR.

C12 - STORMWATER MANAGEMENT NOTES:

C12.3 THIS DEVELOPMENT IS CONSIDERED EXEMPT FROM ON-SITE STORMWATER DETENTION CONTROLS BASED ON WILLIAMSON COUNTY SUBDIVISION REGULATION B11.1.3, WHICH STATES THAT A PROPOSED DEVELOPMENT MAY BE CONSIDERED EXEMPT FROM PROVIDING ON-SITE STORMWATER DETENTION IF ALL LOTS ARE 2 ACRES OR MORE AND LESS THAN 20% OF IMPERVIOUS COVER PER LOT.

OTHER NOTES:

- 1. DRIVEWAY SPACING TO ALL LOTS WITHIN THIS SUBDIVISION SHALL BE A MINIMUM OF 30-FEET MEASURED FROM EDGE OF DRIVEWAY TO EDGE OF DRIVEWAY.
2. IT IS THE RESPONSIBILITY OF THE OWNER, NOT THE COUNTY, TO ASSURE COMPLIANCE WITH THE PROVISIONS OF ALL APPLICABLE STATE, FEDERAL AND LOCAL LAWS AND REGULATIONS RELATING TO THE PLATTING AND DEVELOPMENT OF THIS PROPERTY.
3. THE COUNTY ASSUMES NO RESPONSIBILITY FOR THE ACCURACY OF REPRESENTATIONS BY OTHER PARTIES IN THIS PLAT. FLOODPLAIN DATA, IN PARTICULAR, WILL CHANGE OVER TIME AND THE CURRENT EFFECTIVE FLOODPLAIN DATA TAKES PRECEDENCE OVER FLOODPLAIN DATA REPRESENTED ON THIS PLAT. IT IS FURTHER UNDERSTOOD THAT THE OWNERS OF THE TRACT OF LAND COVERED BY THIS PLAT MUST INSTALL AT THEIR OWN EXPENSE ALL TRAFFIC CONTROL DEVICES AND SIGNAGE THAT MAY BE REQUIRED BEFORE THE STREETS IN THE SUBDIVISION HAVE BEEN ACCEPTED FOR MAINTENANCE BY THE COUNTY.
4. IMPROVEMENTS WITHIN THE COUNTY ROAD RIGHT-OF-WAY INCLUDING, BUT NOT LIMITED TO, LANDSCAPING, IRRIGATION LIGHTING, CUSTOM SIGNS, IS PROHIBITED WITHOUT FIRST OBTAINING AN EXECUTED LICENSE AGREEMENT WITH WILLIAMSON COUNTY.
5. NO CONSTRUCTION IN THE SUBDIVISION MAY BEGIN UNTIL THE TEXAS COMMISSION ON ENVIRONMENTAL QUALITY (TCEQ) HAS APPROVED THE WATER POLLUTION ABATEMENT PLAN (WPAP) IN WRITING.
6. ON-SITE SEWAGE FACILITIES MUST BE DESIGNED BY A REGISTERED PROFESSIONAL ENGINEER OR REGISTERED SANITARIAN.

OWNER CERTIFICATION:

STATE OF TEXAS KNOW ALL MEN BY THESE PRESENTS
COUNTY OF WILLIAMSON

I, RHONDA AND BRUCE CARNLEY CO-OWNERS OF THE CERTAIN TRACT OF LAND SHOWN HEREON AND DESCRIBED IN A DEED RECORDED IN DOCUMENT NO. 2022080320 OF THE OFFICIAL RECORDS OF WILLIAMSON COUNTY, TEXAS, AND DO HEREBY (SUBDIVIDE RESUBDIVIDE, AMEND, ETC.) SAID TRACT AS SHOWN HEREON, AND DO HEREBY CONSENT TO ALL PLAT NOTE REQUIREMENTS SHOWN HEREON, AND DO HEREBY FOREVER DEDICATE TO THE PUBLIC THE ROADS, ALLEYS, RIGHTS-OF-WAY, EASEMENTS AND PUBLIC PLACES SHOWN HEREON FOR SUCH PUBLIC PURPOSES AS WILLIAMSON COUNTY MAY DEEM APPROPRIATE. AND DO HEREBY STATE THAT ALL PUBLIC ROADWAYS AND EASEMENTS AS SHOWN ON THIS PLAT ARE FREE OF LIENS. THIS SUBDIVISION IS TO BE KNOWN AS "REPLAT OF LOT 20, 21 AND 22, SECTION 3 - LOST RIVER RANCHES"

TO CERTIFY WHICH, WITNESS BY MY HAND THIS DAY OF 2026

NAME: RHONDA CARNLEY

NAME: BRUCE CARNLEY

ADDRESS: 116 DB WOODS ROAD, GEORGETOWN TEXAS, 78628

STATE OF TEXAS KNOW ALL MEN BY THESE PRESENTS
COUNTY OF

BEFORE ME, THE UNDERSIGNED, A NOTARY PUBLIC IN AND FOR SAID COUNTY AND STATE, ON THIS DAY PERSONALLY APPEARED Rhonda Carnley, KNOWN TO ME TO BE THE PERSON WHOSE NAME IS SUBSCRIBED TO THE FOREGOING INSTRUMENT.

GIVEN UNDER MY HAND AND SEAL OF OFFICE THIS 2 DAY OF March, 2026.

NOTARY PUBLIC IN AND FOR THE STATE OF TEXAS

MY COMMISSION EXPIRES ON: 6-19-2026

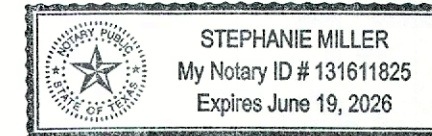

STATE OF TEXAS KNOW ALL MEN BY THESE PRESENTS
COUNTY OF

BEFORE ME, THE UNDERSIGNED, A NOTARY PUBLIC IN AND FOR SAID COUNTY AND STATE, ON THIS DAY PERSONALLY APPEARED Bruce Carnley, KNOWN TO ME TO BE THE PERSON WHOSE NAME IS SUBSCRIBED TO THE FOREGOING INSTRUMENT.

GIVEN UNDER MY HAND AND SEAL OF OFFICE THIS 2 DAY OF March, 2026.

NOTARY PUBLIC IN AND FOR THE STATE OF TEXAS

MY COMMISSION EXPIRES ON: 6-19-2026

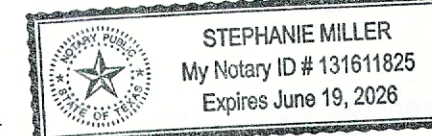

STATE OF TEXAS KNOW ALL MEN BY THESE PRESENTS
COUNTY OF WILLIAMSON

I, BRUCE L. BRYAN, DO HEREBY CERTIFY THAT THE INFORMATION CONTAINED ON THIS PLAT COMPLIES WITH THE SUBDIVISION REGULATIONS ADOPTED BY WILLIAMSON COUNTY, TEXAS.

TO CERTIFY WHICH, WITNESS MY HAND AND SEAL AT GEORGETOWN, WILLIAMSON, TEXAS, THIS

02 DAY OF MARCH, 2026

BRUCE L. BRYAN, RPLS

REGISTERED PROFESSIONAL SURVEYOR NO. 4249 STATE OF TEXAS



I, ALEJANDRO E. GRANADOS RICO, DO HEREBY CERTIFY THAT THE INFORMATION CONTAINED ON THIS PLAT COMPLIES WITH THE SUBDIVISION REGULATIONS ADOPTED BY WILLIAMSON COUNTY, TEXAS. THIS TRACT IS LOCATED WITHIN THE EDWARDS AQUIFER RECHARGE ZONE.

TO CERTIFY WHICH, WITNESS MY HAND AND SEAL AT GEORGETOWN, WILLIAMSON, TEXAS, THIS

2 DAY OF March, 2026

ALEJANDRO E. GRANADOS RICO, P.E. REGISTERED PROFESSIONAL ENGINEER NO. 130084 STATE OF TEXAS



ON-SITE SEWAGE APPROVAL

BASED UPON THE ABOVE REPRESENTATIONS OF THE ENGINEER OR SURVEYOR WHOSE SEAL IS AFFIXED HERETO, AND AFTER A REVIEW OF THE SURVEY AS REPRESENTED BY THE SAID ENGINEER OR SURVEYOR, I FIND THAT THIS PLAT COMPLIES WITH THE REQUIREMENTS OF EDWARDS AQUIFER REGULATIONS FOR WILLIAMSON COUNTY AND WILLIAMSON COUNTY ON-SITE SEWAGE FACILITY REGULATIONS. THIS CERTIFICATION IS MADE SOLELY UPON SUCH REPRESENTATIONS AND SHOULD NOT BE RELIED UPON FOR VERIFICATIONS OF THE FACTS ALLEGED. THE WILLIAMSON COUNTY ENGINEER'S OFFICE AND WILLIAMSON COUNTY DISCLAIMS ANY RESPONSIBILITY TO ANY MEMBER OF THE PUBLIC FOR INDEPENDENT VERIFICATION OF THE REPRESENTATIONS, FACTUAL OR OTHERWISE, CONTAINED IN THIS PLAT AND THE DOCUMENTS ASSOCIATED WITH IT.

Adam D. Boatright, P.E. COUNTY ENGINEER 03/03/2026

THE STATE OF TEXAS KNOW ALL MEN BY THESE PRESENTS:
COUNTY OF WILLIAMSON

CONSENT OF LIENHOLDER:

I, MCB CRE, INC. LIEN HOLDER OF THE CERTAIN TRACT OF LAND SHOWN HEREON AND DESCRIBED IN A DEED RECORDED IN DOCUMENT NO. 2022080320 OF THE OFFICIAL RECORDS OF WILLIAMSON COUNTY, TEXAS, DO HEREBY CONSENT TO THE SUBDIVISION OF SAID TRACT AS SHOWN HEREON, DO FURTHER HEREBY JOIN, APPROVE AND CONVEY TO ALL RESTRICTIONS LISTED HEREIN, AND DO HEREBY DEDICATE TO WILLIAMSON COUNTY THE STREETS, ALLEYS, RIGHTS-OF-WAY, EASEMENTS AND PUBLIC PLACES SHOWN HEREON FOR SUCH PUBLIC PURPOSES AS WILLIAMSON COUNTY MAY DEEM APPROPRIATE. THIS SUBDIVISION IS TO BE KNOWN AS "REPLAT OF LOT 20, 21 AND 22, SECTION 3 - LOST RIVER RANCHES"

LIENHOLDER NAME:

MCB CRE, INC.

BY:

NAME:

TITLE:

BEFORE ME, THE UNDERSIGNED AUTHORITY, A NOTARY PUBLIC IN AND FOR SAID COUNTY AND STATE, ON THIS

THE 2 DAY OF March, 2026, PERSONALLY APPEARED Brandon Batek, CLO OF MCB CRE, INC., AN AUTHORIZED DULY AUTHORIZED AGENT WITH AUTHORITY TO SIGN SAID DOCUMENT, PERSONALLY KNOWN TO ME (AND PROVED TO ME ON THE BASIS OF SATISFACTORY EVIDENCE) TO BE THE PERSON WHOSE NAME IS SUBSCRIBED TO THE FOREGOING INSTRUMENT, AND ACKNOWLEDGED TO ME THAT (S)HE EXECUTED THE SAME FOR THE PURPOSES AND CONSIDERATION THEREIN EXPRESSED.

GIVEN UNDER MY HAND AND SEAL OF OFFICE THIS 2 DAY OF March, 2026.

NOTARY PUBLIC IN AND FOR THE STATE OF TEXAS

PRINTED NAME: Stephanie Miller

MY COMMISSION EXPIRES ON: 6-19-2026

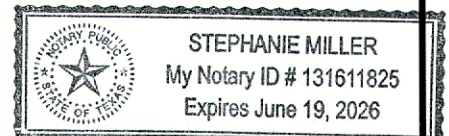

ROAD NAME AND 911 ADDRESSING APPROVAL

ROAD NAME AND ADDRESS ASSIGNMENTS VERIFIED THIS THE 3 DAY OF March, 2026 A.D.

WILLIAMSON COUNTY ADDRESSING COORDINATOR

COUNTY JUDGE CERTIFICATION:

THE STATE OF TEXAS KNOW ALL MEN BY THESE PRESENTS:
COUNTY OF WILLIAMSON

I, STEVEN SNELL, COUNTY JUDGE OF WILLIAMSON COUNTY, TEXAS, DO HEREBY CERTIFY THAT THIS MAP OR PLAT, WITH FIELD NOTES HEREON, THAT A SUBDIVISION HAVING BEEN FULLY PRESENTED TO THE COMMISSIONERS' COURT OF WILLIAMSON COUNTY, TEXAS, AND BY THE SAID COURT DULY CONSIDERED, WERE ON THIS DAY APPROVED AND PLAT IS AUTHORIZED TO BE REGISTERED AND RECORDED IN THE PROPER RECORDS OF THE COUNTY CLERK OF WILLIAMSON COUNTY, TEXAS.

STEVEN SNELL, COUNTY JUDGE WILLIAMSON COUNTY, TEXAS

COUNTY CLERK'S CERTIFICATION:

I, NANCY E. RISTER, CLERK OF THE COUNTY COURT OF SAID COUNTY, DO HEREBY CERTIFY THAT THE FOREGOING INSTRUMENT IN WRITING, WITH ITS CERTIFICATE OF AUTHENTICATION WAS FILED FOR RECORD IN MY OFFICE ON

THE DAY OF 2026, A.D., AT O'CLOCK, M., AND DULY RECORDED THIS

THE DAY OF 2026, A.D., AT O'CLOCK, M., IN THE OFFICIAL PUBLIC RECORDS OF SAID COUNTY IN

DOCUMENT NO. OF THE OFFICIAL PUBLIC RECORDS OF WILLIAMSON COUNTY, TEXAS

TO CERTIFY WHICH, WITNESS MY HAND AND SEAL AT THE COUNTY COURT OF SAID COUNTY, AT MY OFFICE IN GEORGETOWN, TEXAS, THE DATE LAST SHOWN ABOVE WRITTEN.

NANCY E. RISTER, CLERK COUNTY COURT OF WILLIAMSON COUNTY, TEXAS

BY: DEPUTY

REPLAT OF LOT 20, 21, AND 22 SECTION 3 LOST RIVER RANCHES BEING 22.19 ACRE SUBDIVISION SITUATED IN THE A. H. PORTER SURVEY, ABSTRACT 490 WILLIAMSON COUNTY, TEXAS



501 S. AUSTIN AVENUE, SUITE 1310 GEORGETOWN, TEXAS 78626 STATE OF TEXAS REGISTRATION # F-928 TEL. NO. (512) 418-1771 WWW.KIMLEY-HORN.COM

Table with 6 columns: SCALE, DRAWN BY, CHECKED BY, DATE, PROJECT NO., SHEET NO. Values: N/A, AEG, AEG, 02/26/2026, 069412700, 2 OF 2

FILED NAME: K:\GEO_CIVIL\069412700 - LOST RIVER RANCHES\CAD\PRELIMINARY\PLANS\REPLAT\06.DWG PLOTTED BY: GRANADOS, ALEX 2/26/2026 4:33 PM LAST SAVED: 2/26/2026 9:31 PM

Commissioners Court - Regular Session

21.

Meeting Date: 03/10/2026

Authorize Issuing IFB #26IFB33 North Barker Street for Road Bonds Program/HNTB

Submitted For: Joy Simonton

Submitted By: Fernando Ramirez, Purchasing

Department: Purchasing

Agenda Category: Consent

Information

Agenda Item

Discuss, consider, and take appropriate action on authorizing the Purchasing Agent to advertise and receive sealed responses for IFB North Barker Street, under IFB #26IFB33. The funding source is P689.

Public Background

Fiscal Impact

From/To	Acct No.	Description	Amount
---------	----------	-------------	--------

Attachments

Form Review

Inbox

County Judge Exec Asst.

Form Started By: Fernando Ramirez

Final Approval Date: 03/02/2026

Reviewed By

Delia Colon

Date

03/02/2026 02:59 PM

Started On: 02/25/2026 03:11 PM

Commissioners Court - Regular Session

22.

Meeting Date: 03/10/2026

On-Call Material Testing (CR 110) – HVJ – WA#1

Submitted By: Ragan Riggs, Road Bond

Department: Road Bond

Agenda Category: Consent

Information

Agenda Item

Discuss, consider, and take appropriate action on Work Authorization No. 1 to the On-Call Materials Testing (CR 110N) contract, dated September 11, 2024, between Williamson County and HVJ South Central Texas – M&J, Inc. relating to the 2023 Road Bond Program.

Public Background

Fiscal Impact

From/To	Acct No.	Description	Amount
---------	----------	-------------	--------

Attachments

Form Review

Inbox

County Judge Exec Asst.

Form Started By: Ragan Riggs

Final Approval Date: 03/04/2026

Reviewed By

Delia Colon

Date

03/04/2026 08:31 AM

Started On: 03/02/2026 10:42 AM

Commissioners Court - Regular Session

23.

Meeting Date: 03/10/2026

On-Call Environmental (Ronald Reagan, Seg C1) – SWCA – WA#13

Submitted By: Ragan Riggs, Road Bond

Department: Road Bond

Agenda Category: Consent

Information

Agenda Item

Discuss, consider, and take appropriate action on Work Authorization No. 13 to the On-Call Environmental Services (Ronald Reagan, Segment C1) contract, dated May 9, 2024, between Williamson County and SWCA, Incorporated dba SWCA Environmental Consultants relating to the 2023 Road Bond Program.

Public Background

Fiscal Impact

From/To	Acct No.	Description	Amount
---------	----------	-------------	--------

Attachments

Form Review

Inbox

County Judge Exec Asst.

Form Started By: Ragan Riggs

Final Approval Date: 03/04/2026

Reviewed By

Delia Colon

Date

03/04/2026 08:31 AM

Started On: 03/02/2026 10:44 AM

Commissioners Court - Regular Session

24.

Meeting Date: 03/10/2026

Alan McMillin – Recognition of Service to Williamson County as Red Cross Volunteer.

Submitted For: Bruce Clements

Submitted By: Bruce Clements, Emergency Services Dept.

Department: Emergency Services Dept.

Agenda Category: Regular Agenda Items

Information

Agenda Item

Discuss, consider and take appropriate action on approving a Resolution recognizing Alan McMillin for his years of dedicated service to Williamson County as an American Red Cross volunteer and partner to the Williamson County Office of Emergency Management.

Public Background

Alan McMillin served Williamson County for six years as an External Relations Volunteer Lead and Government Liaison with the American Red Cross, concluding more than eleven years of total Red Cross service in January 2026. During his service, Mr. McMillin worked closely with the Williamson County Office of Emergency Management and other county partners to strengthen local preparedness, response, and recovery capabilities. He assisted in identifying and securing fifteen shelter facilities across the County and regularly supported Emergency Operations Center activations, including the July 2025 flood event. In addition to his local service, he deployed to eight national disaster operations and brought back important lessons from those responses.

Fiscal Impact

From/To	Acct No.	Description	Amount
---------	----------	-------------	--------

Attachments

Commissioners Court Resolution - McMillin

Form Review

Inbox

County Judge Exec Asst.

Form Started By: Bruce Clements

Final Approval Date: 03/03/2026

Reviewed By

Delia Colon

Date

03/03/2026 09:48 AM

Started On: 03/03/2026 09:22 AM

State of Texas

County of Williamson

Know all men by these presents:

THAT ON THIS, the 10th day of March 2026, the Commissioners Court of Williamson County, Texas, met in duly called session at the Courthouse in Georgetown, with the following members present;

Steven Snell, County Judge

Terry Cook, Commissioner, Precinct One

Cynthia P. Long, Commissioner, Precinct Two

Valerie Covey, Commissioner, Precinct Three

Russ Boles, Commissioner, Precinct Four

And at said meeting, among other business, the Court considered the following

RESOLUTION

RECOGNIZING ALAN MCMILLIN FOR HIS DEDICATED SERVICE TO WILLIAMSON COUNTY

WHEREAS, Alan McMillin faithfully served the residents of Williamson County for six years as an External Relations Volunteer Lead and Government Liaison with the American Red Cross, concluding more than eleven years of total service in January 2026; and

WHEREAS, as a trusted partner to the Williamson County Office of Emergency Management, he strengthened the County's preparedness, response, and recovery capabilities through steady leadership, coordination, and professionalism; and

WHEREAS, Alan was instrumental in identifying and securing fifteen shelter locations across the County and became a valued presence in the Emergency Operations Center, helping coordinate shelter operations and disaster support efforts, including during the July 2025 flood event; and

WHEREAS, he further strengthened community resilience by deploying to eight national disasters, serving in leadership roles and supporting communities across the nation during times of crisis; and

WHEREAS, he invested in the preparedness of Williamson County by training local volunteers in Red Cross Shelter Fundamentals and Shelter Simulation courses, ensuring a capable and ready shelter workforce to care for residents during future emergencies;

NOW, THEREFORE, BE IT RESOLVED THAT Williamson County Commissioners Court hereby expresses its sincere appreciation and gratitude to Alan McMillin for his dedication, leadership, and lasting contributions to the safety and resilience of Williamson County, Texas.

RESOLVED this 10th day of March, 2026.

Steven Snell, Williamson County Judge

Commissioners Court - Regular Session

25.

Meeting Date: 03/10/2026

Colorectal Cancer Proclamation

Submitted For: Cynthia Long

Submitted By: Kathy Pierce, Commissioner Pct. #2

Department: Commissioner Pct. #2

Agenda Category: Regular Agenda Items

Information

Agenda Item

Hear a presentation on colorectal cancer and discuss, consider and take appropriate action on naming the month of March 2026 as "National Colorectal Cancer Awareness Month" in Williamson County.

Public Background

Fiscal Impact

From/To	Acct No.	Description	Amount
---------	----------	-------------	--------

Attachments

Proclamation

Form Review

Inbox

County Judge Exec Asst.

Form Started By: Kathy Pierce

Final Approval Date: 02/27/2026

Reviewed By

Delia Colon

Date

02/27/2026 10:29 AM

Started On: 02/26/2026 05:35 PM

State of Texas
County of Williamson
Know all men by these presents:

That on the 10th day of March 2026 the Commissioners Court of Williamson County, Texas met in duly called session at the Williamson County Courthouse, 710 Main Street, Georgetown, Texas, with the following members present:

Steven Snell, County Judge
Terry Cook, Commissioner Precinct One
Cynthia P. Long, Commissioner Precinct Two
Valerie Covey, Commissioner Precinct Three
Russ Boles, Commissioner Precinct Four

And at said meeting, among other business, the Court considered the following Proclamation:

WHEREAS, Colorectal Cancer is the 4th most commonly diagnosed cancer in the U.S. and the 2nd leading cause of cancer death, but is the leading cause of U.S. cancer deaths for men and women under the age of 50; and

WHEREAS, there were an estimated 154,270 people in the U.S. diagnosed with colon and rectal cancer in 2025, and 1,076 new cases were reported in Williamson County residents between 2018 and 2022; and

WHEREAS, Colorectal Cancer accounted for more than 50,000 deaths in the U.S. last year and took the lives of 348 Williamson County residents during 2019 – 2023; and

WHEREAS, raising awareness helps more people recognize risks, symptoms and the importance of preventative screenings to detect the disease early, when it is highly treatable with the 5-year survival rate is about 90% when detected early in the localized stage; and,

WHEREAS, there may be no symptoms of Colorectal Cancer in the early stages, which is why it is important to get screened early for polyps and colorectal cancer, when it is treatable; and

WHEREAS, it is important to discuss with your doctor any changes in bowel habits, persistent abdominal discomfort, such as pain, nausea, cramping, bloating, and/or feeling unusually full, even when you haven't eaten much; or noticing bleeding when going to the bathroom; weakness and/or fatigue; unexplained weight loss; and your family history since the disease runs in families; and

WHEREAS, the Williamson County and Cities Health District, with the support of the Williamson County Commissioners Court can provide education about this disease and screening from the comfort of your home, where no fasting, bowel prep, sedation or anesthesia is necessary, and no need to take off time from work; and

WHEREAS, Williamson County urges anyone to speak with their doctor and/or to request information on a preventative screening for early detection through the Williamson County & Cities Health District.

NOW THEREFORE, BE IT RESOLVED, that the Williamson County Commissioners Court declares the month of March 2026 as **“National Colorectal Cancer Awareness Month”** in Williamson County.

PROCLAIMED THIS 10th Day of March 2026.

Steven Snell, County Judge

Commissioners Court - Regular Session

26.

Meeting Date: 03/10/2026

Alternate Vehicle Replacement Schedule for Specific OEM and FM Vehicles

Submitted By: Ashlie Holladay, Budget Office

Department: Budget Office

Agenda Category: Regular Agenda Items

Information

Agenda Item

Discuss, consider and take appropriate action on an alternate vehicle replacement schedule for the Office of Emergency Management and Fire Marshal Office response vehicles as identified in the attached.

Public Background

The OEM and FM offices are asking for an alternate replacement schedule for five specific units (as attached) in their respective departments. The alternate schedule would say only one of the two criteria, or "age OR miles" be met, instead of the current approved policy that states both criteria must be met, or "age AND miles." The Budget office did explore a lease option, but that is nearly double the cost. The OEM and FM offices are stating that these vehicles sit at various fire stations as well as the ESOC and must be "deployment ready." Williamson County has roughly 5 incidents each year, while outside agencies have circa 25 incidents for a total of 30 annually where trailers need to be deployed. Since most of the time these vehicles are sitting, they will not reach age AND MILES as required by the current replacement schedule. The OEM and FM offices are asking to replace these diesel trucks with a 1/2 ton gas, Ford F150 or Chevy equivalent, which is a much less expensive solution (vehicle cost as well as maintenance) and Fleet preferred. The Fleet Committee voted 7 for and 2 against this alternate replacement schedule. Should an alternate replacement schedule be approved, units being replaced will be re-purposed/allocated to another department during the budget process until meeting age AND miles replacement criteria.

Fiscal Impact

From/To	Acct No.	Description	Amount
---------	----------	-------------	--------

Attachments

Fleet Replacement Schedule
OEM and FM Fleet

Form Review

Inbox

County Judge Exec Asst.

Form Started By: Ashlie Holladay

Final Approval Date: 03/02/2026

Reviewed By

Delia Colon

Date

03/02/2026 01:43 PM

Started On: 02/26/2026 03:34 PM

Fleet Replacement Criteria

The proposed fleet replacement criteria are based on over 20 years of usage patterns, maintenance history, and industry experience. Over time, technology and manufacturing changes have highlighted the necessity to update the usage requirements to meet safety, efficiency and lifecycle-cost standards.

TYPE-DESCRIPTION		Current
AUTOMOBILES & SUVS		REPLACEMENT
P-1	PRIMARY VEHICLES	7 yrs& 100,000 miles
	PRIMARY PATROL UNITS	4 yrs & 100,000 miles
PICKUPS & VANS		
PV-1	Light Duty (Class 1&2 - to 10,000 GVW)	11 yrs & 132,000 miles
	Front Line Ambulance	3 yrs & 100,000 miles
TRUCKS		
T-1	Light Duty, gas (Class 3&4 - to 16,000 GVW)	11 yrs & 132,000 miles
T-2	Light Duty, diesel (Class 3 & 4 - to 16,000GVW)	11 yrs & 180,000 miles
	Med Duty (Class 5,6 & 7 - to 35,000 GVW)	10 yrs& 200,000 miles
	Heavy duty (Class 8 - over 35,000 GVW)	10 yrs & 275,000 miles
CONSTRUCTION EQUIPMENT		
C-1	Motor Graders	14 yrs & 6,500 hrs
C-2	Gradall Excavators,Track Excavators, Wheeled Excavators	10 yrs & 6,500 hrs
C-3	Backhoe Loaders	14 yrs & 6,500 hrs
C-4	Wheel Loaders	15 yrs & 6,500 hrs
C-5	Compact Rollers	15 yrs & 4,000 hrs
C-6	Track Loaders, Dozers	15 yrs & 6,000 hrs
PAVING EQUIPMENT		
P-1	Asphalt Distributors	10 yrs & 85,000 miles
P-2	Asphalt Pavers	15 yrs & 6,500 hrs
P-3	Chip Spreaders	14 yrs & 3,500 hrs
P-4	Road Brooms	14 yrs & 3,500 hrs
P-5	Truck Mounted Sweeper	12 yrs & 60,000 miles
MOWING EQUIPMENT		
M-1	Mowing Tractors	12 year rotation
M-2	Boom Mowers	14 yrs & 3,000 hrs
M-3	Batwing mowers	6 year rotation
	Riding Mowers	10 yrs
	Sand Rake- Toro for Parks	10 yrs & 5000 hrs
TRAILERS		
	Gross load capacity of 4,500 lbs or greater	15 yrs

MISCELLANEOUS POWER EQUIPMENT		
	Water Pumps, Welding Machines, Concrete Saws	
	Forklifts, ETC	15 yrs

FIRE MARSHAL FLEET

Unit	Vehicle Year	Make	Model	Miles	YTD Maint. \$\$\$	Current	Alternate Replacement Schedule
HM5 (ZB0990)	2009	Dodge	Ram3500	65,249	\$ 11,324	11yrs AND 180,000	11yrs OR 180,000
HM4 (ZB1689)	2016	Ford	F550	10,457	\$ 14,533	10yrs AND 200,000	10yrs OR 200,000
HM7 (ZT0886)	2008	Ford	F450	30,984	\$ 20,913	11yrs AND 180,000	11yrs OR 180,000
HM3 (ZB1935)	2019	Ford	F350	8,429	\$ 6,795	11yrs AND 180,000	11yrs OR 180,000

One of these vehicles will remain as a Float

EMERGENCY MANAGEMENT FLEET

Unit	Vehicle Year	Make	Model	Miles	YTD Maint. \$\$\$	Current	Alternate Replacement Schedule
OEMS1 (GB1201)	2012	Dodge	Ram3500	67,584	\$ 16,899	11yrs AND 180,000	11yrs OR 180,000
OEMS2 (GB1366)	2013	Chevy	Silverado	87,632	\$ 9,698	11yrs AND 132,000	11yrs OR 132,000

Commissioners Court - Regular Session

27.

Meeting Date: 03/10/2026

Line Item Transfer

Submitted By: Ashlie Holladay, Budget Office

Department: Budget Office

Agenda Category: Regular Agenda Items

Information

Agenda Item

Discuss, consider and take appropriate action on a line item transfer for the District Attorney's Office.

Public Background

This is a Line-Item Transfer for funding the Williamson County District Attorney's payment of legal fees incurred and outstanding in relation to litigation pertaining to rules under Chapter 56 in Title 1 of the Texas Administrative Code regarding reporting requirements of District and County Attorneys.

Fiscal Impact

From/To	Acct No.	Description	Amount
FROM	0100-0440-001100	Dist Atty/FT Salary	\$22,343
TO	0100-0440-004100	Dist Atty/Prof Svcs	\$22,343

Attachments

No file(s) attached.

Form Review

Inbox

County Judge Exec Asst.

Form Started By: Ashlie Holladay

Final Approval Date: 03/03/2026

Reviewed By

Delia Colon

Date

03/03/2026 04:56 PM

Started On: 03/03/2026 04:46 PM

Commissioners Court - Regular Session

28.

Meeting Date: 03/10/2026

Line Item Transfer

Submitted By: Ashlie Holladay, Budget Office

Department: Budget Office

Agenda Category: Regular Agenda Items

Information

Agenda Item

Discuss, consider and take appropriate action on a line item transfer for the District Attorney's Office.

Public Background

This is a Line-Item Transfer requested by the Williamon County District Attorney for purposes of funding the payment of future legal fees in relation to litigation pertaining to rules under Chapter 56 in Title 1 of the Texas Administrative Code regarding reporting requirements of District and County Attorneys.

Fiscal Impact

From/To	Acct No.	Description	Amount
FROM	0100-0409-004100	Non Dept/Prof Svcs	\$145,000
TO	0100-0440-004100	Dist Atty/Prof Svcs	\$145,000

Attachments

No file(s) attached.

Form Review

Inbox

County Judge Exec Asst.

Form Started By: Ashlie Holladay

Final Approval Date: 03/03/2026

Reviewed By

Delia Colon

Date

03/03/2026 04:57 PM

Started On: 03/03/2026 04:53 PM

Commissioners Court - Regular Session

29.

Meeting Date: 03/10/2026

Wilco Local Alcohol Distance Regulations

Submitted By: Hal Hawes, General Counsel

Department: General Counsel

Agenda Category: Regular Agenda Items

Information

Agenda Item

Discuss, consider, and take appropriate action on adopting the Williamson County Local Alcohol Distance Regulations to enact regulations applicable in the unincorporated area of Williamson County, Texas prohibiting the sale of alcoholic beverages within certain distances of churches, public or private schools, and public hospitals in accordance with Texas Alcohol Beverage Code Section 109.33.

Public Background

Fiscal Impact

From/To	Acct No.	Description	Amount
---------	----------	-------------	--------

Attachments

Wilco Local Alcohol Distance Regulations

Form Review

Inbox

County Judge Exec Asst.

Form Started By: Hal Hawes

Final Approval Date: 03/04/2026

Reviewed By

Delia Colon

Date

03/04/2026 08:31 AM

Started On: 03/03/2026 08:14 PM

THE STATE OF TEXAS §
COUNTY OF WILLIAMSON §

WILLIAMSON COUNTY LOCAL ALCOHOL DISTANCE REGULATIONS

WHEREAS, the Texas Alcohol Beverage Code Section 109.33 authorizes the commissioners court of a county to enact regulations applicable in the unincorporated area of the county prohibiting the sale of alcoholic beverages within certain distances of churches, public or private schools, and public hospitals; and

WHEREAS, the Texas Alcohol Beverage Code further authorizes a commissioners court to adopt additional procedures, require notice to schools, and grant variances when warranted; and

WHEREAS, the Commissioners Court of Williamson County finds that reasonable local alcohol distance regulations serve an important public purpose, protect public health and safety, and provide clarity to applicants, affected institutions, and the public; and

WHEREAS, these regulations shall apply throughout all unincorporated areas of Williamson County, Texas;

WHEREAS, these regulations shall supersede all previous Williamson County alcohol distance regulations to the extent of any conflict, except that any other Williamson County regulation not addressed herein shall remain in effect; and,

NOW THEREFORE, BE IT ORDERED BY THE COMMISSIONERS COURT OF WILLIAMSON COUNTY THAT SUBJECT TO THE REQUIREMENTS OF STATE LAW THAT THE FOLLOWING RESTRICTIONS ARE HEREBY ADOPTED:

SECTION I. DEFINITIONS

All terms have the same meaning as found in Texas Alcoholic Beverage Code Section 109, as applicable.

SECTION II. SALE OF ALCOHOL RESTRICTIONS

A. General Restrictions

1. The sale of alcoholic beverages is prohibited within 300 feet of a church, public or private school, or public hospital.
2. The sale of alcoholic beverages is prohibited within 1,000 feet of a public school, if the Commissioners Court receives and approves a request from a school district under Section 38.007, Texas Education Code.

3. The sale of alcoholic beverages is prohibited within 1,000 feet of a private school, if the Commissioners Court receives and approves a request from the governing body of the private school.
4. Except as provided by Texas Alcohol Beverage Code Section 109.331, distance restrictions for public schools also apply to a day-care center and a child-care facility as those terms are defined by Section 42.002, Texas Human Resources Code.

B. Requirements for School Requests for 1,000-Foot Restrictions

1. Requests shall be in writing and addressed to the County Judge.
2. Requests shall state the reason(s) the additional distance restriction is sought.
3. Requests shall include a map depicting the campus or school property with the requested 1,000-foot distance boundary shown.
4. Public school requests must specify:
 - a. How the request complies with Section 38.007, Texas Education Code; and
 - b. Whether the restriction is requested for one campus or district wide.
5. Requests for 1,000 foot restrictions shall be effective upon approval by Commissioners Court.
6. Williamson County shall maintain a master list of all schools with an approved 1,000-foot distance restriction on file in the County Judge's Office, available to applicants upon request.

C. Measurement Requirements

1. The measurement of the distance between the places of business where alcoholic beverages are sold are as follows:
 - a. For churches and public hospitals, the specified distance is measured along the property lines of the street fronts and from front door to front door, and in direct line across intersections.
 - b. For public or private schools, the specified distance is measured:
 - i. In direct line from the property line to property line, and in a direct line across intersections; or
 - ii. If the permit holder or license holder is located on or above the fifth story of a building, in a direct line from the property line of the school to the property line of the place of business, in a direct line across intersections, and vertically up the building at the property line to the base of the floor on which the permit or license holder is located.

D. Applicant Requirements

1. Every applicant for an original alcoholic beverage license or permit shall:
 - a. Bear full responsibility for confirming all required measurements with the County Judge's Office.
 - b. Establish measurements by either:
 - i. A written measurement confirmation from the local TABC office, submitted to the County Judge's Office; or

- ii. A sworn measurements affidavit supported by a survey prepared by a Texas-licensed surveyor or engineer. The required form of affidavit is available upon request at the County Judge's Office.
2. Written Notice:
 - a. Applicants must provide written notice to any public or private school located within 1,000 feet of the business's entrance before filing a TABC application.
 - b. A copy of the notice must be submitted to TABC with the application.
 - c. This notice requirement does not apply to premises where minors are prohibited under Section 109.53, Texas Alcoholic Beverage Code.
3. The County Judge's Office shall maintain the affidavit form for Applicant use.

E. Exemptions

1. Section II. A (2.) & (3.) of these regulations do not apply to the holder of:
 - a. A retail on-premises consumption permit or license if less than 50 percent of gross receipts for the premises are from the sale or service of alcoholic beverages;
 - b. A retail off-premises consumption permit or license if less than 50 percent of the gross receipts for the premises, excluding the sale of items subject to the motor fuels tax, are from the sale or service of alcoholic beverages; or
 - c. A wholesaler's, distributor's, brewer's, distiller's and rectifier's, or winery permit or license, or any other license or permit held by a wholesaler or manufacturer as those words are ordinarily used and understood in Chapter 102, Texas Alcoholic Beverage Code.
 - d. A performing arts facility leased to a nonprofit organization under a policy adopted under Section 11.179, Education Code.
2. Section II. A (3.) of these regulations do not apply to the holder of:
 - a. A permit issued under Chapter 30, Texas Alcoholic Beverage Code, who is operating on the premises of a private school; or
 - b. A license or permit covering a premise where minors are prohibited from entering under Section 109.53, Texas Alcoholic Beverage Code, and is located within 1,000 feet of a private school.
3. Section II. A (1.) of these regulations do not apply to the holder of:
 - a. License or permit who also holds a food and beverage certificate covering a premise that is located within 300 feet of a private school; or
 - b. A license or permit covering a premise where minors are prohibited from entering under Section 109.53, Texas Alcoholic Beverage Code, and is located within 300 feet of a private school.

SECTION III. VARIANCES

- A. The Commissioners Court may grant variances to these distance restrictions if it determines that enforcement in a particular instance:
 1. Is not in the best interest of the public;
 2. Constitutes waste or inefficient use of land or resources;
 3. Creates an undue hardship on an Applicant for a license or permit;

4. Does not serve its intended purpose;
5. Is not effective or necessary; or
6. For any other reason, after considering public health, safety, welfare, and the equities of the situation, a variance is in the best interest of the community.

B. Variance requests must identify:

1. The date the application was initiated with TABC; and
2. All reasons the variance is warranted.

C. Variance requests shall be submitted in writing to the County Commissioner for the precinct where the property is located. A Commissioner receiving the request may place the item on Commissioners Court agenda for consideration.

D. If a variance is granted, the Commissioners Court shall issue a written order identifying any conditions or limitations.

SECTION IV. SEVERABILITY

If any part or provision of these regulations or their application to any person or circumstance is held invalid by a court of competent jurisdiction, the invalidity shall be limited to that portion and shall not affect the remainder of the regulation. The Commissioners Court declares that it would have adopted the valid sections independently.

SECTION V. MISCELLANEOUS

These regulations are to activate Texas Alcohol Beverage Code Section 109.33 as it applies to churches, public or private schools, and public hospitals in Williamson County, Texas and are not meant to substitute for state law regarding the subject matter of the regulations. To the extent there is a conflict with these regulations and Texas Alcohol Beverage Code Section 109.33, as it may be amended, Texas Alcohol Beverage Code Section 109.33 shall control.

PASSED AND APPROVED BY COMMISSIONERS COURT THIS 10th DAY OF MARCH, 2026.

Steven Snell, County Judge

Terry Cook, Commissioner, Precinct 1

Cynthia Long, Commissioner, Precinct 2

Valerie Covey, Commissioner, Precinct 3

Russ Boles, Commissioner, Precinct 4

Commissioners Court - Regular Session

30.

Meeting Date: 03/10/2026

Authorize Issuing 26RFP34 Food Truck Management and Scheduling Services for Administrative Building for County Manager's Office

Submitted For: Joy Simonton

Submitted By: Joy Simonton, Purchasing

Department: Purchasing

Agenda Category: Regular Agenda Items

Information

Agenda Item

Discuss, consider, and take appropriate action on authorizing the Purchasing Agent to advertise and receive sealed responses for Food Truck Management and Scheduling Services for Administrative Building, under RFP #26RFP34. There is no cost to Williamson County for this service. The added fee for service will be paid for by County employees as they order meals.

Public Background

Fiscal Impact

From/To	Acct No.	Description	Amount
---------	----------	-------------	--------

Attachments

Form Review

Inbox

County Judge Exec Asst.

Form Started By: Joy Simonton

Final Approval Date: 03/03/2026

Reviewed By

Delia Colon

Date

03/03/2026 12:27 PM

Started On: 03/03/2026 12:05 PM

Commissioners Court - Regular Session

31.

Meeting Date: 03/10/2026

Urban Area Security Initiative Federal Grant FY'26 for County Sheriff

Submitted For: Matthew Lindemann

Submitted By: Starla Hall, Sheriff

Department: Sheriff

Agenda Category: Regular Agenda Items

Information

Agenda Item

Discuss, consider and take appropriate action authorizing the Williamson County Sheriff's Office to apply for funding through the Office of the Governor's FY2026 Urban Area Security Initiative Federal Grant Program.

Public Background

The Sheriff's Office is seeking approval to apply for approximately \$454,510 through the Urban Area Security Initiative (UASI) Federal Grant Program. Funds awarded will be used to purchase an armored tactical vehicle. This grant requires no match. A resolution and CEO/Law Enforcement Certification and Assurances Form are required. Staff recommends the following action: Approve the Sheriff's Office to apply for the FY2026 UASI Federal Grant Program and authorize appropriate County department personnel to complete documentation relevant to the implementation of the grant.

Fiscal Impact

From/To	Acct No.	Description	Amount
---------	----------	-------------	--------

Attachments

Grants Management Request Questionnaire
CEO/Law Enforcement Cert & Assurances Form
Resolution

Form Review

Inbox

County Judge Exec Asst.
Form Started By: Starla Hall
Final Approval Date: 03/02/2026

Reviewed By

Delia Colon

Date

03/02/2026 10:49 AM
Started On: 02/27/2026 02:46 PM

Grant Title/Project Name:	WILCO SO Armored Tactical Vehicle
Department:	Sheriff's Office
Requestor:	Dana Foster
Contact Email:	dana.foster@wilcotx.gov
Contact Phone Number:	512.943.1168
Start Date:	10/1/2026
End Date:	9/30/2028
Please select request category:	Asset, Armored Tactical Vehicle
Describe the purpose of the grant in detail to include all requirements.	This grant will fund the purchase of an armored tactical vehicle, providing protection during high-risk operations such as active shooter responses, terrorist incidents, hostage situations, and the service of high-risk warrants.
Select the type of grant your department is applying for:	Federal Pass-thru
What is the amount of the grant?	\$454,510.00
Please provide a breakdown of the total cost above.	The package price of \$454,510.00 includes the vehicle, freight, and all custom features, such as a 360° camera, ballistic steel plating, armored glass, roof hatches, specialized communications, rescue equipment, lighting package, and run-flat off-road tires.
Is there a match requirement?	No
What is the source of the match?	
Does the grant cover the cost of the request 100%?	Yes
If not, how much is left unpaid?	
What is the plan to obtain grants/funds for the remaining amount?	
List other similar assets in the County and/or region and if they are available for use?	
How is this asset request different from any similar assets currently in the County and/or region?	
What types of events/purpose would this asset be used for that cannot be accomplished with a current County asset?	
How often do these events occur?	
Identify the number of personnel required to operate this asset and/or be available for the function where it is to be used? How much time is required of those personnel? What is the cost of the personnel?	
Where will the asset be stored?	
What is the useful life of the asset?	
Will a replacement be requested from general funds when useful life has been exhausted?	

Will other agencies be billed for the use of this asset (e.g. vendors paid, employee worked hours and paid, inventory costs etc.)?	
Does this asset require insurance coverage?	
If yes, what is the estimate of asset insurance coverage?	
Will this asset require on-going maintenance? Please describe the maintenance required along with an estimate for these costs.	
How will this asset be funded when the grant ends?	
What is the impact if the grant is not received?	
New Personnel position is:	
Where will this position office?	
Who will this position report to?	
What tasks will this position perform? Include the five primary functions and the percentage of time spent to be spent on each function.	
Will this position take over tasks from current County employee?	
If yes, please explain the impact to current employee.	
How will this position be funded when the grant ends?	
Does this position or a similar position currently exist within the department?	
If yes, how many of these similar positions exist?	
Describe any alternatives considered to achieve desired outcome in lieu of a position (i.e. equipment, software, technology or change in business practice).	
Describe how workload will be accomplished/re-allocated should grant not be approved.	
List other similar items in the County and/or region and if they are available for use?	WILCO Sheriff's Office SWAT Team currently has a 16-year-old tactical vehicle that is nearing its end of service life and has higher maintenance costs because of this. Its equipment and safety features are out of date, and some items on it are broken and no longer serviceable. Round Rock Police, Travis County Sheriff's Office, Austin Police, Texas DPS, and Central Texas SWAT Team have similar vehicles, but they are only available if not currently in use.
How is this item request different from any similar assets currently in the County and/or region?	The new vehicle will be tailored to meet the current and future needs of WILCO Sheriff's Office, offer the newest safety features and technologies, require less maintenance than the existing vehicle, and eventually replace it when it meets its end of service life. Unlike similar regional assets, this vehicle will be dedicated to the department and available at all times.
What types of events/purpose would this item be used for that cannot be accomplished with a current County asset?	The tactical vehicle will be utilized for the same operations as the current vehicle, primarily high-risk incidents including counterterrorism missions, active shooter response, hostage rescue, barricaded suspects, and warrant service; however, it will provide enhanced safety for officers and civilians and will eventually replace the existing unit.

Identify the number of personnel required to operate this item and/or be available for the function where it is to be used?	Minimum of two people to operate the equipment.
Please explain how this item will create the need for more or less personnel (or mark n/a for no change)?	NA
Where will the item be stored?	Sheriff's Office Impound Yard
What is the useful life of the item?	15+ years
Will other agencies be billed for the use of this item (e.g. vendors paid, employee worked hours and paid, inventory costs etc.)?	
Does this item require insurance coverage?	Yes
Will this item require any form of licensing?	No
Will this item require on-going maintenance? Please describe the maintenance required along with an estimate for these costs?	Approximate annual cost of \$5,000 for normal preventative maintenance and anticipated repairs.
How will this item be funded when the grant ends?	Costs associated with the vehicle upkeep will be funded through general funds.
What is the overall budgetary impact? (i.e. revenue generation, expense reduction, etc.)	The estimated annual maintenance and insurance cost for the new vehicle is approximately \$5,400. Once the current vehicle reaches the end of its service life and is removed from service, its associated maintenance costs will be eliminated; therefore, the additional budgetary impact should be negligible.
Please identify any additional equipment needed/required (now or in the future) should the grant/asset is awarded.	NA
What is the cost and frequency to maintain/update the additional equipment?	NA
What is the impact of this grant application on other internal/county departments?	Normal preventative maintenance associated with vehicles. Required reporting and tracking normally associated with grants.
If yes, what is the estimate of that license fee?	
If yes, what is the estimate of insurance coverage?	404
Will a replacement be requested from general funds when useful life has been exhausted? (OR)	No
If yes, how much is the match amount?	
Please identify any known decrease in funding at this time.	NA
Is this a new program to your department/office?	Yes
Please provide data points to be collected to show program success	Data will be collected to track the number of calls for service the vehicles respond to.
Please show historical data points or performance measures, statistics, services provided, etc. or any/all updates for re-application	
ID	20
Version	3.0
Attachments	False

Created	2/26/2026 11:11 AM
Created By	Dana Foster
Modified	2/26/2026 11:58 AM
Modified By	Dana Foster



**Office of the Governor
Public Safety Office –CEO/Law Enforcement Certifications and Assurances Form**

Entity Name: Williamson County	Date:
Agency/Department Name: Williamson County Sheriff's Office	
Name of Chief Executive Officer: Judge Steven Snell	
Name of Head of Law Enforcement Agency: Sheriff Matthew Lindemann	

Certification Required by CEO and Head of Law Enforcement Agency

In our respective capacities as chief executive officer of Williamson County (“Grantee”) and as head of Williamson County Sheriff's Office (“Agency”), we hereby each certify that Grantee and Agency participate fully, and will continue to participate fully from the date of this certification until the later of August 31, 2026 or the end of the grant project period, in all aspects of the programs and procedures utilized by the U.S. Department of Homeland Security (“DHS”) to: (1) notify DHS of all information requested by DHS related to illegal aliens in Agency’s custody; and (2) detain such illegal aliens in accordance with requests by DHS.

We further certify that Grantee and Agency do not have, and will continue not to have until the later of August 31, 2026 or the end of the grant project period, any policy, procedure, or agreement (written or unwritten) that in any way limits or impedes Agency’s receipt or DHS’s issuance of detainer requests, or in any way limits or restricts Grantee’s and Agency’s full participation in all aspects of the programs and procedures utilized by DHS to: (1) notify DHS of all information requested by DHS related to illegal aliens in Agency’s custody; and (2) detain such illegal aliens in accordance with requests by DHS.

Additionally, we certify that neither Grantee nor Agency have in effect, purport to have in effect, or are subject to or bound by any law, rule, policy, or practice (written or unwritten) that would: (1) require or authorize the public disclosure of federal law enforcement information in order to conceal, harbor, or shield from detection fugitives from justice or aliens illegally in the United States; or (2) impede federal officers from exercising authority under 8 U.S.C. § 1226(a), § 1226(c), § 1231(a), § 1357(a), § 1366(1), or § 1366(3).

Lastly, we certify that Grantee and Agency will comply with all provisions, policies, and penalties found in Chapter 752, Subchapter C of the Texas Government Code.

We acknowledge that failure to comply with this certification may result in OOG, in its sole discretion, terminating any grant made by OOG to Grantee, and that Grantee must return all funds received from OOG for any grant terminated under this certification. We further acknowledge that Grantee will remain ineligible for OOG funding until it provides satisfactory evidence that the jurisdiction has complied with this certification for at least one year.

Signature
Chief Executive Officer for Grantee

Matthew Lindemann

Signature
Head of Agency

IN THE COMMISSIONERS COURT OF WILLIAMSON COUNTY, TEXAS

WHEREAS, The Williamson County Commissioners Court finds it in the best interest of the citizens of Williamson County, that the WCSO Armored Tactical Vehicle be operated for the FY2026; and

WHEREAS, Williamson County Commissioners Court agrees that in the event of loss or misuse of the Office of the Governor funds, Williamson County Commissioners Court assures that the funds will be returned to the Office of the Governor in full.

WHEREAS, Williamson County Commissioners Court designates the Williamson County Judge as the grantee's authorized official. The authorized official is given the power to apply for, accept, reject, alter or terminate the grant on behalf of the applicant agency.

NOW THEREFORE, BE IT RESOLVED that Williamson County Commissioners Court approves submission of the grant application for the WCSO Armored Tactical Vehicle to the Office of the Governor.

Passed by Commissioners Court and Signed on this date: March 10,2026

Steven Snell, County Judge
On behalf of the Williamson County Commissioners Court Members

Grant Number: 5922701

Commissioners Court - Regular Session

32.

Meeting Date: 03/10/2026

MOU between Williamson County Emergency Medical Services (CHP) and WellMed

Submitted For: John Gonzales

Submitted By: John Gonzales, EMS

Department: EMS

Agenda Category: Regular Agenda Items

Information

Agenda Item

Discuss, consider, and take appropriate action on approving a MOU between Williamson County Emergency Medical Services and WellMed and authorizing the County Judge to sign the same and any necessary related documents.

Public Background

Williamson County Emergency Medical Services is entering into a 12-month pilot program (MOU) with WellMed Medical Management designed to strengthen local healthcare access and reduce taxpayer costs through a partnership between the WCEMS Community Health Paramedic team and WellMed Medical Management. This pilot integrates Community Health Paramedicine, a proven, evidence-based model for transitional and preventative care, with WellMed’s care coordination framework. Community Paramedics provide proactive in-home visits, follow-up assessments, medication reconciliation, and health education for high-risk, recently discharged, or frequently-employed patients.

Fiscal Impact

From/To	Acct No.	Description	Amount
---------	----------	-------------	--------

Attachments

Form Review

Inbox

County Judge Exec Asst.

Form Started By: John Gonzales

Final Approval Date: 03/02/2026

Reviewed By

Delia Colon

Date

03/02/2026 08:45 AM

Started On: 02/27/2026 03:54 PM

Commissioners Court - Regular Session

33.

Meeting Date: 03/10/2026

Juvenile Services Texas Parks and Wildlife Grant

Submitted By: Denise Carlson, Juvenile Services

Department: Juvenile Services

Agenda Category: Regular Agenda Items

Information

Agenda Item

Discuss, consider and take appropriate action for Juvenile Services to accept a \$49,697.00 grant through Texas Parks and Wildlife to provide outdoor programs for youth.

Public Background

Juvenile Services is requesting approval to accept a \$49,697.00 grant from Texas Parks and Wildlife to provide outdoor programming for youth. Juvenile Services has participated in the grant since 2005, successfully providing hiking, biking, fishing, camping and paddling, rock-climbing and other activities for youth. The grant will cover the entire cost of these activities and has no in-kind match requirement. Approval to apply for this grant was granted to Juvenile Services at the 8/19/2025 Commissioners Court meeting.

Fiscal Impact

From/To	Acct No.	Description	Amount
---------	----------	-------------	--------

Attachments

GO! Grant Docs

Form Review

Inbox

County Judge Exec Asst.

Form Started By: Denise Carlson

Final Approval Date: 03/03/2026

Reviewed By

Delia Colon

Date

03/03/2026 12:17 PM

Started On: 03/03/2026 10:47 AM

Proposed Project Details

Williamson County - Juvenile Services

COOP-2026-WilliamsonCo_JS-00008

Project Timeline

Based on your Program Performance Goals, provide a timeline for the proposed grant-funded program activities to be delivered. Be sure to clearly list all proposed TPWD relationships, including TPWD trainings, sites, or staff visits. Do not include planning meetings or internal deadlines. Keep in mind, the period of performance will be **March 1st, 2026 to September 1st, 2027** (18 months), and all activities must fall within this period. *

- Program dates should be listed in chronological order during the 18-month performance period.
- Programs listed in March/April/May are allowed but grant funds are not disbursed during the initial agreement phase (March 1-May 30th). Be sure programs listed on the timeline in these months are realistic for your organization and account for participant recruitment, staff training, and upfront costs.

Tentative Dates (Month / Year)	Location	Activity
March 2026	Brushy Creek Lake Park, Cedar Park	Staff introduction to paddling, biking and fishing
March (Spring Break) 2026	San Gabriel Park, Georgetown	fishing and/or biking
March (Spring Break) 2026	McKinney Falls State Park	hiking and fishing
April 2026	San Gabriel Park, Georgetown	Outdoor Family Night - fishing and biking
April 2026	Round Rock Park West, Round Rock	Outdoor Family Night - fishing and biking
April 2026	Bull Branch Park, Taylor	Outdoor Family Night - fishing and biking
April 2026	Brushy Creek Lake Park, Cedar Park	Outdoor Family Night - fishing and biking
May 2026	San Gabriel Park, Georgetown	biking and/or fishing
June 2026	Inks Lake State Park	paddling
June 2026	Inks Lake State Park	paddling
August 2026	Brushy Creek Lake Park, Cedar Park	paddling
September 2026	San Gabriel Park, Georgetown	Outdoor Family Night - fishing and biking
September 2026	Round Rock Park West, Round Rock	Outdoor Family Night - fishing and biking
September 2026	Bull Branch Park, Taylor	Outdoor Family Night - fishing and biking
September 2026	Brushy Creek Lake Park, Cedar Park	Outdoor Family Night - fishing and biking
November 2026	Mother Neff State Park	Outdoor Service Project
November 2026	Juvenile Justice Center, Georgetown	environmental education and leadership development
November 2026	Juvenile Justice Center, Georgetown	environmental education and leadership development
November 2026	Juvenile Justice Center, Georgetown	environmental education and leadership development
December 2026	Juvenile Justice Center, Georgetown	environmental education and leadership development
December 2026	Juvenile Justice Center,	Career Development Presentation

Proposed Project Details

Williamson County - Juvenile Services

COOP-2026-WilliamsonCo_JS-00008

January or February 2027	Georgetown San Gabriel Park, Georgetown	biking and/or fishing
March (Spring Break) 2027	Pedernales Falls State Park	hiking and fishing
March (Spring Break) 2027	San Gabriel Park, Georgetown	fishing and/or biking
March (Spring Break) 2027	Mother Neff State Park	Outdoor Service Project
April 2027	San Gabriel Park, Georgetown	Outdoor Family Night - fishing and biking
April 2027	Round Rock Park West, Round Rock	Outdoor Family Night - fishing and biking
April 2027	Bull Branch Park, Taylor	Outdoor Family Night - fishing and biking
April 2027	Brushy Creek Lake Park, Cedar Park	Outdoor Family Night - fishing and biking
June 2027	Inks Lake State Park	paddling
Spring - June 2027	TBA	make-up trips for any previous cancellations

Program Itinerary (optional but highly recommended)
Upload *Program Itinerary* document (as a single PDF):

https://tpwd-recgrants.intelligrants.com/_Upload/47635_1124991_2-ProgramItineraryfor2026COOPGrantApplication.pdf

Project Participants

Participant demographics and total un-duplicated participants served will be included in your grant agreement requirements, if awarded. To ensure successful completion of all contract requirements, please ensure the numbers provided are conservatively estimated and realistic for your organization.

Total Unduplicated Participants To Be Served by Grant Project

Total number of unduplicated participants directly served by the project. Demographic data is required to be collected for each unduplicated participant.

250

Please explain how you calculated the total number of participants served (500 characters max)

We have historically exceeded this estimated number but we want to remain conservative in our calculations. Based on the number of planned grant activities and the fact that 12 of these activities will include the families of our youth participants, we feel confident in this estimation.

Provide assurance of participant attendance for the proposed project. Explain how you will recruit participants and/or which partner groups will provide participants, if applicable. (1000 character max)

Field Probation Officers and Case Managers work together to refer participants from their caseload who they feel will benefit from participation in a particular activity. Although those who are referred to an activity are "required" to attend, there are often participants who don't show up even though they face a consequence for failing to attend. In anticipation of any "failure to attend" issues, our officers will attempt to enroll a few referrals above the desired attendance numbers as often as possible. Outdoor Family Nights, residents of the CORE residential program and Prevention Program referrals have historically been reliable in their attendance so we feel confident we will meet our proposed participant estimate.

Proposed Project Details

Community Partnership Letter(s)

If your recruitment plan and assurances include partnering with other organizations (schools, non-profits, etc.), please upload a partnership letter from all organizations agreeing to provide participants. This is not a general endorsement of your organization, and letters should clearly identify the specific program commitment, number of participants and/or demographics of participants. ([Sample Partnership Letter](#))

Upload Community Partnership Letter(s) (combined into single PDF):

Participant Demographics

CO-OP's primary purpose is to connect new audiences to TPWD sites, programs, and resources, and engage underserved participants in outdoor education and conservation. A minimum of 40% of grant funded program participants must meet at least one of the demographic categories below:

Target Audience	Definition
Female	Female participants of any age.
Low Income	Defined by USDA Food Eligibility Guidelines for the Free & Reduced School Lunch Program or by federal/local poverty guidelines.
Individuals w/a disability	Includes physical, intellectual, behavioral, developmental, learning, and other identified disabilities. Includes caretakers or family of disabled individuals accompanying participant.
Minority	Includes physical, intellectual, behavioral, developmental, learning, and other identified disabilities. Includes caretakers or family of disabled individuals accompanying participant.

Provide a breakout of participant demographics below, along with a detailed explanation for how you estimated the percentage and how you will ensure this percentage of participants will be served. Data specific to the population served must be used and general census data, including zip code/city/neighborhood data is not specific enough to award participant population points in the review process. Ideal examples of estimating participant demographics include:

- Partner school demographics if all or most participants are recruited through that school. In most circumstances, general school district demographics (ISD) are not specific enough to provide assurances unless projects are serving a majority of district students.
- Commitments from partners to provide project participants and who collect similar demographic information that they are willing to provide to the sponsor organization.
- Past demographics that document the proposed demographic collected by your organization for the proposed or other similar programs.
- Self-reported data collected from individuals expected to participate in the proposed scope of work, such as a registration form that collects the required demographic data.

*** If awarded a grant, you will be required to report individual participant demographics for the actual participants served, if you are proposing at least 40% or more of any category.** If you are not claiming to serve at least 40% or if you are not able to collect data for certain demographics, enter 0% in the application. Supporting documentation must be available upon request.

Demographic	% of Total Participants	Explain calculation & assurances of how % will be met
Female	40 %	this percentage is based on the average of our last two grant cycles
Low Income	50 %	we surpassed this percentage in our last two grant cycles
Individuals w/ a disability	40 %	this percentage is based on the average of our last

Proposed Project Details

Williamson County - Juvenile Services

COOP-2026-WilliamsonCo_JS-00008

Minority	50 %	two grant cycles we surpassed this percentage in our last two grant cycles
----------	------	--

Demographics Tracking

Do you currently track the above requested demographics for participants served?

Yes No

Project Budget Details

Williamson County - Juvenile Services

COOP-2026-WilliamsonCo_JS-00008

Project Cost Summary and Budget Narrative

Do you charge a program or a membership fee to participate in this proposed project?

Yes No

If yes, explain the cost breakout and what specific budget items those fees are used to support. A nominal fee to reserve participation in a program or ensure attendance is allowable. If participant cost is over a nominal fee, applicants must provide a detailed explanation of what the specific fees support for grant-funded programs and differentiate those items in the requested budget funds. CO-OP prefers grant funded programs to be free or low-cost to participants. The grant program does not fund scholarships. (4000 characters or less)

Itemized Budget

·Provide your proposed grant budget in whole dollar amounts (rounded) and ensure all items listed are supported in your Project Proposal.

Personnel costs must include number of hours and hourly rate.

·General categories such as "kayaking supplies" and "fishing supplies" are encouraged, but provide examples of items in these categories in the Budget Summary section below.

·Do not use "Program Supplies" or "Education supplies" categories, as they are too broad.

·Requested funding will be disallowed for any ineligible items listed in your budget and that dollar amount will be deducted from the total grant award.

·For additional guidelines on eligible items, please refer to the [CO-OP Program Guidance](#) and see the [Sample Budget](#) in the RGO CO-OP resources section.

	# of Hours	Hourly Rate	Total Funds Requested	<i>For TPWD use only</i> TPWD Grant Funds Approved
PROJECT COSTS				
Personnel and Employer-paid			\$37,216.56	\$37,216.56
FICA				
Grant Coordinator Administration Work Hours (contract/no FICA)	260	\$50.00	\$13,000.00	\$13,000.00
Grant Coordinator Guide	270	\$35.00	\$9,450.00	\$9,450.00

Project Budget Details

Williamson County - Juvenile Services

COOP-2026-WilliamsonCo_JS-00008

Hours(contract/no FICA)				
Guide Hours	568	\$24.15	\$13,717.20	\$13,717.20
FICA 7.65% for Guide Hours (combined)	1	\$1,049.36	\$1,049.36	\$1,049.36

	# of Units	Cost Per Unit	Total Funds Requested	TPWD Grant Funds Approved
--	-------------------	----------------------	------------------------------	----------------------------------

PROJECT COSTS

Food/Transportation

			\$4,490.00	\$4,490.00
Food (consolidated): Snacks, Beverages, Meals Approved Events Only	1	\$4,490.00	\$4,490.00	\$4,490.00
			\$0	
			\$0	
			\$0	
			\$0	

	# of Units	Cost Per Unit	Total Funds Requested	TPWD Grant Funds Approved
--	-------------------	----------------------	------------------------------	----------------------------------

PROJECT COSTS

**Fees (Park, Program, Housing,
Liability Insurance, Training)**

			\$2,590.00	\$2,590.00
WFR Recertifications (2)/Swift Water Training (1)	1	\$1,270.00	\$1,270.00	\$1,270.00
State/county/city park entrance fees, passes and pavilion rentals	1	\$780.00	\$780.00	\$780.00
Grant Coordinator General Liability Insurance for 18 months (Participant Liability Only)	1	\$540.00	\$540.00	\$540.00

	# of Units	Cost Per Unit	Total Funds Requested	TPWD Grant Funds Approved
--	-------------------	----------------------	------------------------------	----------------------------------

PROJECT COSTS

Service Project

			\$3,400.00	\$3,400.00
Native Seeds for Wildflower and Wild grass dispersal (consolidated)	1	\$2,900.00	\$2,900.00	\$2,900.00

Project Budget Details

Williamson County - Juvenile Services

COOP-2026-WilliamsonCo_JS-00008

Variety of hoes, shovels, other digging tools, similar items	1	\$500.00	\$500.00	\$500.00
			\$0	
			\$0	

	# of Units	Cost Per Unit	Total Funds Requested	TPWD Grant Funds Approved
PROJECT COSTS				
Supplies & Equipment			\$2,000.00	\$2,000.00
Biking Supplies	1	\$750.00	\$750.00	\$750.00
Kayaking Supplies	1	\$240.00	\$240.00	\$240.00
Fishing Supplies	1	\$150.00	\$150.00	\$150.00
Family Night and Day Trip Supplies	1	\$730.00	\$730.00	\$730.00
First Aid Supplies, Sunscreen, Bug Spray	1	\$130.00	\$130.00	\$130.00
TOTAL GRANT FUNDS REQUESTED				\$49,697
TOTAL GRANT FUNDS APPROVED				\$49,697

Budget Summary

Include any additional clarification on budget items you feel necessary to explain your budget. If using general categories such as "kayaking supplies," "fishing supplies," etc., please provide examples for these purchases in this section to further clarify. (4000 characters or less)

Biking Supplies – smaller bikes for children (3), water bottle holder clamps, reflectors and clips, bike seats, mini hand pumps (2), regular hand pump

Kayaking Supplies – waterproof box for phone, smaller PFD's for children

Fishing Supplies – worms/bait, tackle box supplies (bobbers, fishing line, weights, pliers, etc.)

Family Night and Day Trip Supplies – heavy duty wagon to carry bins/water jugs and other heavy items, electric tabletop griddle, propane stove carry cases (2), camp chairs (8), mesh food tents to deal with flies around table, propane, etc.

Outdoor Service Project - a variety of wildflower seeds and native grass seeds that can thrive in this growing area (recommended by Park Superintendent), tools to dig out invasive species as well as anything else needed to prepare the land for prairie restoration

TPWD Staff - Itemized Budget Notes: For TPWD use only

Project Budget Details

Williamson County - Juvenile Services

COOP-2026-WilliamsonCo_JS-00008

Consolidated Food
Consolidated native flower and native grass for dispersal line items

Commissioners Court - Regular Session

34.

Meeting Date: 03/10/2026

Approval of Purchase #2026-169 with immix Technology, Inc. for the UKG Pro Timekeeping Annual Purchase and Support for Information Services

Submitted For: Joy Simonton

Submitted By: Jesel Vigil, Purchasing

Department: Purchasing

Agenda Category: Regular Agenda Items

Information

Agenda Item

Discuss, consider, and take appropriate action on approving Purchase #2026-169 between Williamson County and Immix Technology, Inc. for UKG timekeeping software in the amount of \$190,680.00 and authorizing the execution of the purchase pursuant to DIR Contract #DIR-CPO-5688.

Public Background

Fiscal Impact

From/To	Acct No.	Description	Amount
---------	----------	-------------	--------

Attachments

Form Review

Inbox

County Judge Exec Asst.

Form Started By: Jesel Vigil

Final Approval Date: 03/02/2026

Reviewed By

Delia Colon

Date

03/02/2026 11:59 AM

Started On: 02/18/2026 03:37 PM

Commissioners Court - Regular Session

35.

Meeting Date: 03/10/2026

Approval of Contract 2026-174 with Tyler Technologies, Inc. for the FY26 Annual Maintenance and SaaS Subscription for Information Systems

Submitted For: Joy Simonton

Submitted By: Sandra Malcolm, Purchasing

Department: Purchasing

Agenda Category: Regular Agenda Items

Information

Agenda Item

Discuss, consider, and take appropriate action on approving Contract #2026-174 between Tyler Technologies and Williamson County for the Annual Maintenance and SaaS Subscription in the amount of \$649,503.14, utilizing the Sourcewell Cooperative Contract #060624-TTI, and authorizing the execution of the contract.

Public Background

Fiscal Impact

From/To	Acct No.	Description	Amount
---------	----------	-------------	--------

Attachments

Form Review

Inbox

County Judge Exec Asst.

Form Started By: Sandra Malcolm

Final Approval Date: 03/02/2026

Reviewed By

Delia Colon

Date

03/02/2026 03:53 PM

Started On: 02/23/2026 03:49 PM

Commissioners Court - Regular Session

36.

Meeting Date: 03/10/2026

Approval of Services Agreement #2026-176 with CDW Government LLC for the Active Directory Modernization and User/Server Migration Services for Information Systems

Submitted For: Joy Simonton

Submitted By: Sandra Malcolm, Purchasing

Department: Purchasing

Agenda Category: Regular Agenda Items

Information

Agenda Item

Discuss, consider, and take appropriate action to approve the Service Agreement #2026-176 with CDW Government LLC for the Active Directory Modernization and User/Server Migration Services in the amount of \$197,590.00, under the Omnia National Cooperative Contract #R210401, and authorizing the execution of the agreement.

Public Background

Fiscal Impact

From/To	Acct No.	Description	Amount
---------	----------	-------------	--------

Attachments

Form Review

Inbox

County Judge Exec Asst.

Form Started By: Sandra Malcolm

Final Approval Date: 03/03/2026

Reviewed By

Delia Colon

Date

03/03/2026 12:15 PM

Started On: 02/26/2026 03:43 PM

Commissioners Court - Regular Session

37.

Meeting Date: 03/10/2026

Authorize Issuing RFCSP #26RFCSP29 - Jail South Air Handler Unit Replacement for Facilities Management

Submitted For: Joy Simonton

Submitted By: Michelle McKinney, Purchasing

Department: Purchasing

Agenda Category: Regular Agenda Items

Information

Agenda Item

Discuss, consider, and take appropriate action on authorizing the Purchasing Agent to advertise and for contractors to provide Competitive Sealed Proposals for the Jail South AHU Replacement under RFCSP #26RFCSP29, and approving, in the public interest, assigning the price criteria a weighted value of not less than 36.9 percent of the total weighted value of all selection criteria.

Public Background

Fiscal Impact

From/To	Acct No.	Description	Amount
---------	----------	-------------	--------

Attachments

Form Review

Inbox

County Judge Exec Asst.

Form Started By: Michelle McKinney

Final Approval Date: 03/02/2026

Reviewed By

Delia Colon

Date

03/02/2026 12:07 PM

Started On: 02/26/2026 09:31 AM

Commissioners Court - Regular Session

38.

Meeting Date: 03/10/2026

Jester Annex HVAC RTU Replace - Trimbuilt Construction Inc Change Order No 1R

Submitted For: Dale Butler

Submitted By: Gretchen Glenn, Facilities Management

Department: Facilities Management

Agenda Category: Regular Agenda Items

Information

Agenda Item

Discuss, consider, and take appropriate action regarding Change Order No. 1R in the amount of \$204,217.89 for Project 25RFCSP50 Jester Annex HVAC Rooftop Unit (RTU) Replacement (Trimbuilt Construction, Inc.)

Public Background

This Change Order replaces the previously executed Change Order No. 1. The original Change Order #1 entered an incorrect amount listed under the "New Contract Sum including this Change Order" as \$3,204,117.89. This revised Change Order corrects the error by updating the correct "New Contract Sum including this Change Order" to read \$2,504,117.89. All other items from the previous Change Order No. 1 remain the same and no new items have been added to this revised Change Order. This Change Order No. 1 includes moving the Chiller yard 170 feet from its original location, an extension of time by 53 days to Substantial Completion of the project, and a net increase of \$204,217.89. As a result of this Change Order, the net increase is 8.8% in the Contract cost with a new contract sum of \$2,504,117.89.

Fiscal Impact

From/To	Acct No.	Description	Amount
---------	----------	-------------	--------

Attachments

Form Review

Inbox

County Judge Exec Asst.

Form Started By: Gretchen Glenn

Final Approval Date: 03/03/2026

Reviewed By

Delia Colon

Date

03/03/2026 04:30 PM

Started On: 03/03/2026 02:03 PM

Commissioners Court - Regular Session

39.

Meeting Date: 03/10/2026

Approval of Amendment to Master Service Agreement No. 2026-021 with Johnson Controls Fire Protection LP between Williamson County and Facilities Management

Submitted For: Joy Simonton

Submitted By: Cheryl Johnson, Purchasing

Department: Purchasing

Agenda Category: Regular Agenda Items

Information

Agenda Item

Discuss, consider, and take appropriate action to amend the executed Master Service Agreement #2026-021 with Johnson Controls Fire Protection LP between Williamson County and Facilities Management, previously approved by the Commissioners Court on the December 16, 2025, agenda, Item 31, and authorize execution of the amendment.

Public Background

Fiscal Impact

From/To	Acct No.	Description	Amount
---------	----------	-------------	--------

Attachments

Form Review

Inbox

County Judge Exec Asst.

Form Started By: Cheryl Johnson

Final Approval Date: 03/02/2026

Reviewed By

Delia Colon

Date

03/02/2026 11:59 AM

Started On: 02/18/2026 01:59 PM

Commissioners Court - Regular Session

40.

Meeting Date: 03/10/2026

Temporary Road Closure of CR 417

Submitted For: Matt Williamson

Submitted By: Jenifer Favreau, Infrastructure

Department: Infrastructure

Division: Road & Bridge

Agenda Category: Regular Agenda Items

Information

Agenda Item

Discuss, consider and take appropriate action regarding the temporary road closure of CR 417 near CR 418 starting Tuesday, March 17, 2026, continuing through Friday, May 1, 2026, and on approval of a temporary diversion plan for traffic during the closure.

Public Background

This temporary road closure is for the replacement of a drainage structure. A temporary diversion plan for traffic is attached. All properties in the vicinity of the closure will remain accessible throughout the closure by using the diversion plan.

Fiscal Impact

From/To	Acct No.	Description	Amount
---------	----------	-------------	--------

Attachments

Diversion Plan

Form Review

Inbox

County Judge Exec Asst.

Form Started By: Jenifer Favreau

Final Approval Date: 03/03/2026

Reviewed By

Delia Colon

Date

03/03/2026 02:54 PM

Started On: 03/03/2026 02:43 PM

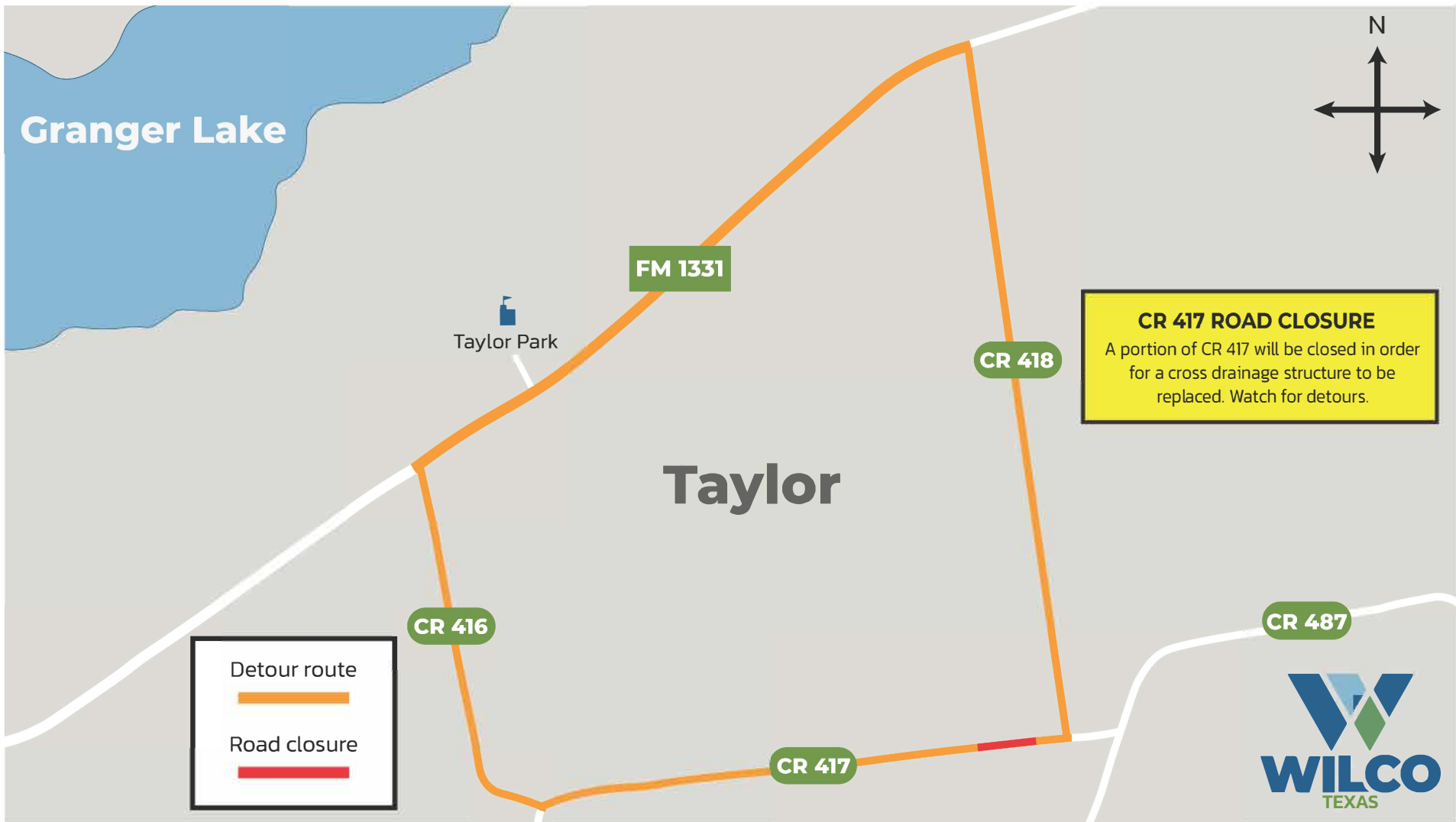

Commissioners Court - Regular Session

41.

Meeting Date: 03/10/2026

License agreement with The Meadows at Chandler Creek MUD for Tiger Trail – Pct 1

Submitted For: Adam Boatright

Submitted By: Misti Schulz, Infrastructure

Department: Infrastructure

Agenda Category: Regular Agenda Items

Information

Agenda Item

Discuss, consider and take appropriate action on approving a license agreement with The Meadows at Chandler Creek MUD for Tiger Trail – Precinct 1.

Public Background

This license agreement is to allow The Meadows at Chandler Creek MUD to install and maintain sidewalk improvements within the right-of-way of Tiger Trail.

Fiscal Impact

From/To	Acct No.	Description	Amount
---------	----------	-------------	--------

Attachments

License Agreement The Meadows at Chandler Creek MUD Tiger Trail

Form Review

Inbox

County Judge Exec Asst.

Form Started By: Misti Schulz

Final Approval Date: 03/04/2026

Reviewed By

Delia Colon

Date

03/04/2026 08:30 AM

Started On: 02/17/2026 12:46 PM

WILLIAMSON COUNTY
LICENSE AGREEMENT

WILLIAMSON COUNTY, TEXAS a political subdivision of the State of Texas (the "County"), and the Municipal Utility District named on the signature page hereinbelow, being a political subdivision of the State of Texas (the "Licensee"), enter into this License Agreement (the "Agreement") upon the terms and conditions set forth below.

I. PURPOSE OF LICENSE AGREEMENT

Licensee has requested permission from County to install, operate, maintain and repair additions, including, but not limited to sidewalks, accessible ramps, trails, landscaping, lighting, fencing, signage and irrigation systems (collectively referred to herein as the "Licensee's Improvements") in portions of the County's right-of-way. Subject to the terms and conditions of this Agreement, the County grants to Licensee permission to install, repair and maintain Licensee's Improvements in the areas of County's right-of-way shown and depicted in the attached **Exhibit "A"** (the "Licensed Property"). The parties acknowledge that this Agreement does not apply to, or affect any interests, rights and obligations regarding water, wastewater, drainage facilities or other utilities located or to be located within the Licensed Property pursuant to any validly issued permits or executed easements related thereto.

The County makes this grant solely to the extent of its right, title and interest in the Licensed Property, without any express or implied warranties.

Licensee agrees that all construction, repair, operation and maintenance permitted by this Agreement shall be done in compliance with the terms and conditions of this Agreement and all applicable County, State and/or Federal police, traffic, building, health and safety ordinances, laws and regulations existing at the time said construction, repair, operation and maintenance is performed.

II. ANNUAL FEE

The County, its governing body, and its respective successors and assigns agree that no annual fee shall be assessed for the license and permission herein granted to Licensee. Licensee agrees that the County's permission and grant of a license hereunder and Licensee's ability to construct Licensee's Improvements on the Licensed Property serve as consideration to support this Agreement.

III. COUNTY'S RIGHTS TO LICENSED PROPERTY

This Agreement is expressly subject and subordinate to the present and future rights of the County, its successors, assigns, lessees, grantees and licensees, to construct, install, establish, maintain, use, operate and renew any public utilities facilities, franchised public utilities, roadways or streets on, beneath or above the surface of the Licensed Property described in Article I above.

Nothing in this Agreement shall be construed to limit, in any way, the power of the County to widen, alter or improve the Licensed Property subject to this Agreement pursuant to official action by the governing body of the County or its successors. The County does, however, agree to

give Licensee at least thirty (30) days written notice of such action and shall cooperate with Licensee to effect the relocation and/or removal of Licensee's Improvements, at Licensee's sole cost, in the event of such widening, altering or improvement of the Licensed Property, further, to cooperate with Licensee wherever possible, to effect such widening, altering or improving of the Licensed Property so that Licensee's Improvements and operations on the Licensed Property will not be materially affected thereby.

Licensee hereby agrees and acknowledges that Licensee, at its expense, shall be responsible for removal of Licensee's Improvements from the Licensed Property within forty-eight (48) hours of County's directive to remove specified Licensee's Improvements whenever such removal is deemed by County necessary for: (a) exercising the County's rights or duties with respect to the Licensed Property; (b) protecting persons or property; or (c) protecting the public health or safety with respect to the Licensed Property. In the event Licensee fails to remove the Licensee's Improvements to the County's satisfaction following County's directive to do so, then and in that event the County may cause the Improvements to be removed at the expense of Licensee.

Notwithstanding any provision in this Agreement to the contrary, the County retains the right to enter upon the Licensed Property, at any time without notice to Licensee, assuming no obligation to Licensee, and remove, repair or replace, without liability to County and at Licensee's expense, any of the Licensee's Improvements thereof whenever such removal is deemed by County necessary for: (a) exercising the County's rights or duties with respect to the Licensed Property; (b) protecting persons or property; or (c) protecting the public health or safety with respect to the Licensed Property.

IV. INSURANCE

Licensee shall, at its sole expense, provide a commercial general liability insurance policy, written by a company acceptable to the County and licensed to do business in Texas, with a combined single limit of not less than One Million and No/100 Dollars (\$1,000,000.00), which coverage may be provided in the form of a rider and/or endorsement to a previously existing insurance policy. Such insurance coverage shall specifically name the County as an additional insured. This insurance coverage shall cover all perils arising from the activities of Licensee, its officers, directors, employees, agents or contractors, relative to this Agreement. Licensee shall be responsible for any deductibles stated in the policy. A true copy of each instrument effecting such coverage shall be delivered to the County on or before the Effective Date.

So long as Licensee is using the Licensed Property, Licensee shall not cause such insurance to be canceled nor permit such insurance to lapse. All insurance certificates shall include a clause to the effect that the policy shall not be canceled, reduced, restricted or otherwise limited until thirty (30) days after the County has received written notice as evidenced by a return receipt of registered or certified mail.

V. INDEMNIFICATION

INDEMNIFICATION - EMPLOYEE PERSONAL INJURY CLAIMS. TO THE FULLEST EXTENT PERMITTED BY LAW, THE LICENSEE SHALL INDEMNIFY, DEFEND (WITH COUNSEL OF COUNTY'S CHOOSING), AND HOLD HARMLESS COUNTY, AND COUNTY'S EMPLOYEES, AGENTS, REPRESENTATIVES, PARTNERS,

OFFICERS, AND DIRECTORS (COLLECTIVELY, THE "INDEMNITEES") AND SHALL ASSUME ENTIRE RESPONSIBILITY AND LIABILITY (OTHER THAN AS A RESULT OF COUNTY'S GROSS NEGLIGENCE) FOR ANY CLAIM OR ACTION BASED ON OR ARISING OUT OF THE PERSONAL INJURY, OR DEATH, OF ANY EMPLOYEE OF THE LICENSEE, OR OF ANY SUBCONTRACTOR, OR OF ANY OTHER ENTITY FOR WHOSE ACTS THEY MAY BE LIABLE, WHICH OCCURRED OR WAS ALLEGED TO HAVE OCCURRED ON THE PROJECT SITE OR IN CONNECTION WITH THE PERFORMANCE OF THE WORK. LICENSEE HEREBY INDEMNIFIES THE INDEMNITEES EVEN TO THE EXTENT THAT SUCH PERSONAL INJURY WAS CAUSED OR ALLEGED TO HAVE BEEN CAUSED BY THE SOLE, COMPARATIVE OR CONCURRENT NEGLIGENCE OF THE STRICT LIABILITY OF ANY INDEMNIFIED PARTY. THIS INDEMNIFICATION SHALL NOT BE LIMITED TO DAMAGES, COMPENSATION, OR BENEFITS PAYABLE UNDER INSURANCE POLICIES, WORKERS COMPENSATION ACTS, DISABILITY BENEFITS ACTS, OR OTHER EMPLOYEES BENEFIT ACTS.

INDEMNIFICATION - OTHER THAN EMPLOYEE PERSONAL INJURY CLAIMS. TO THE FULLEST EXTENT PERMITTED BY LAW, LICENSEE SHALL INDEMNIFY, DEFEND (WITH COUNSEL OF COUNTY'S CHOOSING), AND HOLD HARMLESS INDEMNITEES FROM AND AGAINST CLAIMS, DAMAGES, LOSSES AND EXPENSES, INCLUDING BUT NOT LIMITED TO ATTORNEYS' FEES, ARISING OUT OF OR ALLEGED TO BE RESULTING FROM THE PERFORMANCE OF THIS AGREEMENT OR THE WORK DESCRIBED HEREIN, TO THE EXTENT CAUSED BY THE NEGLIGENCE, ACTS, ERRORS, OR OMISSIONS OF LICENSEE OR ITS SUBCONTRACTORS, ANYONE EMPLOYED BY THEM OR ANYONE FOR WHOSE ACTS THEY MAY BE LIABLE, REGARDLESS OF WHETHER OR NOT SUCH CLAIM, DAMAGE, LOSS OR EXPENSE IS CAUSED IN WHOLE OR IN PART BY A PARTY INDEMNIFIED HEREUNDER.

VI. CONDITIONS

A. Plan Review. Licensee's Improvements shall not be erected, placed, constructed or altered after being constructed on any of the Licensed Property until Licensee's plans and specifications for Licensee's Improvements have been approved, in writing, by County's Engineer or its authorized representatives. Licensee's required plans and specifications for all proposed improvements shall be submitted to County's Engineer and include necessary and applicable details such as site plan, landscape plans, irrigation plans, exterior elevations, drainage and grading plans and/or exterior materials. Approval of plans is at the sole discretion of the County's Engineer. The County Engineer will review all plans in the normal course of business and will make good faith efforts to issue remarks and approvals without unreasonable delay. Once the required plans and specifications are approved by the County Engineer, Licensee hereby acknowledges and agrees that the development and use of the Licensed Property shall thereafter be in strict compliance with the approved plans and specifications or approved amendments thereto.

B. Licensee's Responsibilities. Licensee will be responsible for any damage to and/or for the relocation of existing facilities on the Licensed Property. Further, Licensee shall reimburse the County for all costs of replacing or repairing any property of the County or of others which are damaged or destroyed as a result of activities authorized under this Agreement by, or on behalf of, Licensee.

C. Maintenance. Licensee shall maintain the Licensed Property and the Licensee's Improvements by keeping the area free of debris and litter. Removal of dead or dying plants shall also be handled by Licensee at its expense, as required by the County. Such removal of dead or dying plants shall be completed within fifteen (15) days following receipt of a written request by

the County to do so. If Licensee abandons or fails to maintain the Licensed Property, and the County receives no substantive response within fifteen (15) days following written notification to Licensee, then the County may, in addition to any other remedy set out herein, remove and/or replace all of Licensee's Improvements.

D. Removal or Modification. Licensee agrees that removal or modification of any improvements now existing or to be later replaced on the Licensed Property shall be at Licensee's sole expense. Said removal or modification shall be at Licensee's sole discretion, except where otherwise provided by this Agreement; provided, however, any modification to existing Licensee's Improvements must comply with the Plan Review requirements set out herein.

E. Default. In the event that Licensee fails to maintain the Licensed Property or otherwise comply with the terms or conditions as set forth herein, then the County shall give Licensee written notice thereof to the Licensee at the address set forth below. Licensee shall have fifteen (15) days from the date of receipt of such notice to take action to remedy the failure complained of and, if Licensee does not remedy the same to County's complete satisfaction within the fifteen (15) period, the County may, in addition to other remedies available herein or by law to County, (1) perform the work, (2) contract for the completion of the work, or (3) terminate this Agreement. Licensee agrees to pay, within fifteen (15) days of written demand by the County, all costs and expenses incurred by the County in completing the work or contracting for the work to be completed.

VII. COMMENCEMENT; TERMINATION BY ABANDONMENT

This Agreement shall be effective as of the date of the last party's execution below ("Effective Date"), and continue thereafter for so long as the Licensed Property shall be used for the purposes set forth herein or until this Agreement is terminated according to the terms hereof.

If Licensee abandons the use of all or any part of the Licensed Property for such purposes set forth in this Agreement, then this Agreement, as to such portion or portions abandoned, shall expire and terminate following fifteen (15) days written notice to the Licensee. If such abandonment has not been remedied by Licensee within such period, the County shall thereafter have the same complete title to the Licensed Property so abandoned as though this Agreement had never been made and shall have the right to enter on the Licensed Property and terminate the rights of Licensee, its successors and assigns hereunder. All installations of Licensee's Improvements that are not removed prior to County's termination of the license subject of this Agreement shall be deemed property of the County as of the effective date of County's termination.

VIII. TERMINATION

A. Termination by Licensee. This Agreement, or portion of the Licensed Property, may be terminated by Licensee by delivering written notice of termination to the County not later than thirty (30) days before the effective date of termination. If Licensee so terminates, then Licensee shall, within the 30-day notice period, remove from the Licensed Property, or such other portion thereof that is being terminated, installations of Licensee's Improvements. Any of Licensee's Improvements that are not removed within said period shall become the property of the County. Licensee hereby agrees and acknowledges that Licensee shall be liable to County for any damages

caused to the Licensed Property by the removal of Licensee's Improvements.

B. Termination by County. In addition to any other termination rights set out herein, this Agreement may be revoked and terminated at any time by County if such revocation and termination is reasonably required by the public interest (as hereinafter set forth), after providing fifteen (15) days written notice to the Licensee.

Subject to prior written notification to Licensee or its successors-in-interest, revocation and termination of this Agreement is reasonably required by the public interest if:

1. the County deems, in its sole discretion, that Licensee's Improvements, or a portion of them, interfere with the County's right-of-way;
2. use of the Licensed Property becomes necessary for a public purpose;
3. the Licensee's Improvements, or a portion of them, constitute a danger to the public which the County deems, in its sole discretion, not to be remediable by alteration or maintenance of such improvements;
4. despite fifteen (15) days written notice to Licensee, the County deems, in its sole discretion, maintenance or alteration necessary to alleviate a danger to the public has not been made; or
5. Licensee fails to comply with the terms and conditions of this Agreement including, but not limited to, any insurance requirements specified herein.

IX. MISCELLANEOUS PROVISIONS

A. Venue and Governing Law. Each party to this Agreement hereby agrees and acknowledges that venue and jurisdiction of any suit, right, or cause of action arising out of or in connection with this Agreement shall lie exclusively in Williamson County, Texas. Furthermore, this Agreement shall be governed by and construed in accordance with the laws of the State of Texas, excluding, however, its choice of law rules.

B. Severability. If any provision of this Agreement shall be held invalid or unenforceable by any court of competent jurisdiction, such holding shall not invalidate or render unenforceable any other provision hereof, but rather this entire Agreement will be construed as if not containing the particular invalid or unenforceable provision or provisions, and the rights and obligation of the parties shall be construed and enforced in accordance therewith. The parties acknowledge that if any provision of this Agreement is determined to be invalid or unenforceable, it is the desire and intention of each that such provision be reformed and construed in such a manner that it will, to the maximum extent practicable, give effect to the intent of this Agreement and be deemed to be validated and enforceable.

C. Covenant Running With Land: Waiver of Default. This Agreement and all of the covenants herein shall run with the land; therefore, the conditions set forth herein shall inure to and bind each party's successors and assigns. Either party may waive any default of the other at any time, without affecting or impairing any right arising from any subsequent or other default.

D. Assignment. Licensee shall not assign, sublet or transfer its interest in this Agreement

without the written consent of the County, which consent shall not be unreasonably withheld. In the event County agrees to Licensee's assignment of its interest in this Agreement and subject to the assignee's compliance with the insurance requirements set forth herein, if any, Licensee shall furnish to the County a copy of any such assignment or transfer of any of Licensee's rights in this Agreement, including the name, date, address and contact person.

E. Notices. Excepts as specifically otherwise set forth herein, all notices, demands and requests for delivery of documents or information hereunder shall be in writing and shall be sent to the receiving party at the address identified below and be deemed to have been properly delivered and received (1) as of the time of delivery if personally delivered; (2) as of the time deposited in the mail system if sent by United States certified mail, return receipt requested, and postage prepaid; (3) as of the time of delivery to Federal Express (or comparable express delivery system) if sent by such method with all costs prepaid; or (4) as of the third (3rd) day following the date in which notice is sent by electronic mail (e-mail). All notices, demands and requests hereunder shall be addressed:

To Licensee At:

The address set forth below Licensee's signature block herein below.

To County At:

Williamson County Engineer
3151 S. E. Inner Loop, Suite B
Georgetown, Texas 78626

with copy to: Williamson County Judge
710 Main Street, Ste. 101
Georgetown, Texas 78626

or to such other addresses which either party may so designate by sending notice as aforesaid.

F. Day. Unless otherwise set forth herein, all references herein to a "day" shall mean a calendar day and not a business day.

G. No Third-Party Beneficiaries. This Agreement is for the sole and exclusive benefit of the parties hereto, and nothing in this Agreement, express or implied, is intended to confer or shall be construed as conferring upon any other person any rights, remedies or any other type or types of benefits.

H. Compliance with Laws. Each party to this Agreement shall comply with all federal, state, and local laws, statutes, ordinances, rules and regulations, and the orders and decrees of any courts or administrative bodies or tribunals in any matter affecting the performance of this Agreement

I. Gender, Number and Headings. Words of any gender used in this Agreement shall be held and construed to include any other gender, and words in the singular number shall be held to

include the plural, unless the context otherwise requires. The headings and section numbers are for convenience only and shall not be considered in interpreting or construing this Agreement.

J. Construction. Each party to this Agreement acknowledges that it and its counsel have reviewed this Agreement and that the normal rules of construction are not applicable and there will be no presumption that any ambiguities will be resolved against the drafting party in the interpretation of this Agreement.

K. No Waiver of Immunities. Nothing in this Agreement shall be deemed to waive, modify or amend any legal defense available at law or in equity to County, its past or present officers, employees, or agents or employees, nor to create any legal rights or claim on behalf of any third party. County does not waive, modify, or alter to any extent whatsoever the availability of the defense of governmental immunity under the laws of the State of Texas and of the United States.

L. Force Majeure. If the party obligated to perform is prevented from performance by reasons for which they are not responsible or circumstances beyond their control, including, but without limitation to, “acts of God”, abnormal weather conditions or other natural catastrophes, war, terrorist attacks, sabotage, computer viruses, riots, strikes, lockouts or other industrial disturbances, pandemics, epidemics, health emergencies, disease, plague, quarantine, travel restrictions, discovery of hazardous materials, differing or unforeseeable site conditions, acts of governmental agencies or authorities (whether or not such acts are made in response to other Force Majeure Events), or any other events or circumstances not within the reasonable control of the party affected, whether or not of a similar kind or nature to any of the foregoing (a “Force Majeure Event”). For the avoidance of doubt, Force Majeure Events include the Coronavirus (SARS Cov-2) and such related diseases (e.g. COVID- 19) outbreak., the other party shall grant such party relief from the performance of this Agreement. The burden of proof for the need of such relief shall rest upon the party obligated to perform. To obtain release based on force majeure, the party obligated to perform shall file a written request with the other party and take reasonable efforts undertaken to mitigate its effects.

M. Entire Agreement. This Agreement represents the entire and integrated Agreement between the parties hereto and supersedes all prior negotiations, representations, or agreements, either oral or written. This Agreement may be amended only by written instrument signed by each party to this Agreement. NO OFFICIAL, EMPLOYEE, AGENT, OR REPRESENTATIVE OF THE COUNTY HAS ANY AUTHORITY, EITHER EXPRESS OR IMPLIED, TO AMEND THIS AGREEMENT, EXCEPT PURSUANT TO SUCH EXPRESS AUTHORITY AS MAY BE GRANTED BY THE COUNTY COMMISSIONERS COURT.

TERMS AND CONDITIONS ACCEPTED, to be effective as of the date of the last party's execution below (the "Effective Date").

WILLIAMSON COUNTY, , TEXAS
a political subdivision of the State of Texas

By: _____

Printed Name: _____

Representative Capacity: As Presiding Officer of the
Williamson County Commissioners Court

Date: _____, 20__

THE STATE OF TEXAS §
 §
COUNTY OF WILLIAMSON §

This instrument was acknowledged before me on this the _____ day of _____, 20__ by _____, as Presiding officer of the Williamson County Commissioners Court, on behalf of Williamson County, Texas.

NOTARY PUBLIC, State of Texas

LICENSEE:

The Meadows at Chandler Creek Municipal Utility District,
a political subdivision of the State of Texas

By: Walter Berry

Printed Name: Walter Berry

Title: President

Date: January 20, 2026

Address for Notice:

The Meadows at Chandler Creek MUD
c/o Coats Rose, P.C.
attn: Cole Konopka
2700 Vic Fortuna, Suite 350
Austin, TX 78746
E-mail: ckonopka@coatsrose.com

THE STATE OF TEXAS §
 §
COUNTY OF WILLIAMSON §

This instrument was acknowledged before me on this the 20th day of January, 2026, by Walter Berry, President of the Meadows at Chandler Creek MUD a municipal utility district.

Chloe A. Daniels
NOTARY PUBLIC, State of Texas

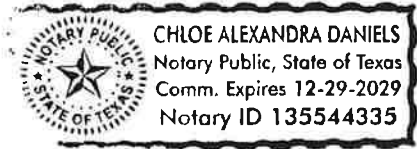

Commissioners Court - Regular Session

42.

Meeting Date: 03/10/2026

Award of IFB #26IFB12 FM734 at Rattan Creek to Aaron Concrete Contractors for Road Bonds/HNTB

Submitted For: Joy Simonton

Submitted By: Vickie Johnson, Purchasing

Department: Purchasing

Agenda Category: Regular Agenda Items

Information

Agenda Item

Discuss, consider, and take appropriate action on awarding IFB #26IFB12 to Aaron Concrete Contractors, LLC for the FM734 at Rattan Creek project for Road & Bridge/HNTB in the amount of \$1,239,349.71 and authorize execution of this agreement, contingent upon TXDOT concurrence. The funding source is P627.

Public Background

Fiscal Impact

From/To	Acct No.	Description	Amount
---------	----------	-------------	--------

Attachments

Form Review

Inbox

County Judge Exec Asst.

Form Started By: Vickie Johnson

Final Approval Date: 03/02/2026

Reviewed By

Delia Colon

Date

03/02/2026 03:40 PM

Started On: 02/26/2026 10:28 AM

Commissioners Court - Regular Session

43.

Meeting Date: 03/10/2026

Ronald Reagan Possession and Use Agreement

Submitted For: Don Childs

Submitted By: Don Childs, Road Bond

Department: Road Bond

Agenda Category: Regular Agenda Items

Information

Agenda Item

Discuss, consider and take appropriate action on a possession and use agreement for transportation purposes with CDJ & Lee, LLC to acquire 9.276 AC and 2.227 AC needed as right of way on the Ronald Reagan Segment D project (Parcel 42).

Public Background

Fiscal Impact

From/To	Acct No.	Description	Amount
---------	----------	-------------	--------

Attachments

Form Review

Inbox

County Judge Exec Asst.

Form Started By: Don Childs

Final Approval Date: 03/04/2026

Reviewed By

Delia Colon

Date

03/04/2026 08:31 AM

Started On: 03/02/2026 06:50 PM

Commissioners Court - Regular Session

44.

Meeting Date: 03/10/2026

Corridor A2 Purchase Contract

Submitted For: Don Childs

Submitted By: Don Childs, Road Bond

Department: Road Bond

Agenda Category: Regular Agenda Items

Information

Agenda Item

Discuss, consider and take appropriate action on a real estate contract with Hjalmar, LLC, a Texas limited liability company, to acquire 5.387 AC needed as right of way and 0.0662 AC needed as a utility easement for the Corridor A2 project (Parcel 34).

Public Background

Fiscal Impact

From/To	Acct No.	Description	Amount
---------	----------	-------------	--------

Attachments

Form Review

Inbox

County Judge Exec Asst.

Form Started By: Don Childs

Final Approval Date: 03/04/2026

Reviewed By

Delia Colon

Date

03/04/2026 08:31 AM

Started On: 03/02/2026 06:55 PM