

2024 DUNNIGAN COMMUNITY PLAN

Yolo County Board of Supervisors

Lucas Frerichs, Chair
Mary Vixie Sandy, Vice Chair
Jim Provenza
Angel Barajas
Oscar Villegas

Yolo County Planning Commission

Troy Bird, Chair
Brian Sala, Vice Chair
Elisabeth Dubin
Pat Reynolds
Amon Muller
Trini Campbell

Dunnigan Citizens Advisory Committee

Neil Busch, Chair
Bill Weber
Junior Guzman
David Hunt
Mel Smith
Anita Tatum
Erich Linse
Aimee Tibbs

Yolo County Department of Community Services

Leslie Lindbo, Director
Stephanie Cormier
JD Trebec, Liaison
Jeff Anderson
Tracy Gonzalez

The staff would like to acknowledge and to especially thank the Dunnigan Citizens Advisory Committee and all the community members who participated in the workshops and public meetings for their hard work and genuine concern about the future of their town.

Contents

1. Introduction	1
Purpose	1
Organization of the Plan	1
Legal Authority	1
Relationship to the Yolo County General Plan.....	1
Governmental Jurisdiction.....	4
Process.....	4
2. The Community Plan Area.....	5
Community Boundary	5
Community Background.....	7
3. Vision, Goals, and Implementation.....	8
Vision	8
Goals and Policies	8
Implementation.....	10
Implementation Programs.....	11
4. Land Use.....	15
Existing Land Use Conditions	15
Land Use Goals	16
5. Agriculture	21
Existing Agriculture Conditions	21
Agriculture Goals	22
Farmland Conservation	22
Agricultural Support and Industry	24
6. Transportation.....	27
Existing Transportation Conditions	27
Transportation Goals	29
Hardwood Grove Access	29
County Road 99W	30
7. Environment and Public Services	32
Existing Environment and Public Services Conditions	32
Environmental Goals.....	34
Air Quality.....	34
Flooding.....	34
Groundwater	35
Fire Hazards	35
Public Services Goals	37
Water and Wastewater.....	37
Law Enforcement, Fire, and Medical Services.....	38
Schools	40

TABLES

<u>Table Number</u>	<u>Page</u>
Table 1. Zoning Consistent with General Plan Land Designations	3
Table 2. Dunnigan Zoning Area Comparison.....	16

FIGURES

<u>Figure Number</u>	<u>Page</u>
Figure 1. Community Location	5
Figure 2. Community Boundary	6
Figure 3. Dunnigan population change.....	7
Figure 4. Dunnigan Land Use Map	13
Figure 5. Dunnigan Zoning Map	14
Figure 6. Potential Land Use Designations for the Town Center Specific Plan	17
Figure 7. Potential Land Use Designations for the West Dunnigan Specific Plan	18
Figure 8. 2021 Crop Permits by Type	21
Figure 9. Areas designated for agricultural mitigation	23
Figure 10. Potential agricultural mitigation areas around Dunnigan.....	24
Figure 11. Parcels suitable for potential I-5 corridor development	25
Figure 12. Access within the Hardwood Grove.....	27
Figure 13. Hardwood Grove Potential Access Improvements (yellow lines).....	29
Figure 14. Main Street, CR 99W, CR 89 Intersection.....	31
Figure 15. California-American Water Service Area	33

APPENDICES

Exhibit A. Parcels with Land Use Designation or Zoning Changes

Attachment 1: Dunnigan Infrastructure Feasibility Study

1. Introduction

Purpose

The purpose of the Dunnigan Community Plan is to protect the characteristics which make Dunnigan a pleasant place to live and to specify the changes which should occur to correct existing problems and to improve the quality of life. The Dunnigan Community Plan seeks to allow additional development that will help provide the services, housing, and commercial opportunities desired by the residents, while preserving and enhancing the agricultural lands and industry which are a vital part of the town's heritage and character.

Organization of the Plan

The Dunnigan Community Plan consists of seven chapters summarized below:

Chapter 1 introduces the Community Plan's purpose and describes legal requirements, organization, relationship to the County General Plan, and the process.

Chapter 2 describes the Community Plan's environment and extents including the Community Growth Boundary and a brief history of the community.

Chapter 3 is a statement of the community's vision and compilation of the Goals and Policies described in the Community Plan brought front and center for ease of use.

Chapters 4 through 7 are the body of the plan addressing specific areas of concern to the community including Land Use, Agriculture, Transportation, and Environment and Public Services. Each chapter describes existing and desired conditions in regard to each area of focus.

Legal Authority

The Dunnigan Community Plan is consistent with California State Government Code Section 65300 which permits cities and counties to prepare and adopt general plans for the physical development of land within their jurisdiction. Administration of a general plan requires the planning agency to investigate and make recommendations to the legislative body regarding reasonable and practical means for implementing the general plan. Community and area plans are parts of the general plan that focus on a particular region or community within the overall general plan area. Such plans refine the policies of the general plan as they apply to a smaller geographic area and are implemented by ordinances and other discretionary actions, such as zoning.

Relationship to the Yolo County General Plan

The Dunnigan Community Plan supplements the Countywide General Plan. It provides guidance specific to Dunnigan which may not be relevant to other parts of the County. On the other hand, most of the goals and policies in the Countywide General Plan have some application to Dunnigan.

The focus of the Yolo County General Plan is to retain the rural character of the County, while directing urban development to existing cities and unincorporated communities such as Dunnigan. In order to retain a separate identity for these towns, Community Growth Boundaries are identified and development is to be located and designed in such a way as to protect, preserve, and perpetuate the small town characteristics and qualities of unincorporated communities.

The 2030 Countywide General Plan includes the following goals and policies that are directly applicable to the Dunnigan Community Plan:

Community Character Element

Goal CC-2 Community Planning lists 16 policies to enhance community planning including increased density and mixed-use development at town centers; communities serving local and surrounding residents as retail, service, and employment centers and where appropriate, regional tourism; providing neighborhood parks, and using sustainable design standards.

Goal CC-3 Planned Development has policies identifying future Dunnigan growth areas and to buffer residential development from Interstates.

Goal CC-4 Project Design includes policies to further sustainable development and “smart growth” planning principals.

Agriculture Element

Goals AG-1 Preservation of Agriculture and AG-3 Healthy Farm Economy include policies to mitigate the conversion of farmland and allow uses that support agriculture such as agricultural commercial and industrial uses, on agricultural lands with appropriate review and development standards.

Economic Development Element

Goals ED-1 Economic Diversity & ED-3 Community Revitalization identify policies to diversify local economies and revitalize communities by ensuring that there is an adequate supply of commercial and industrial land, supporting infill, and improving town center street corridors to protect historical aesthetics and stimulate economic activity.

Goal ED-4 Expansion of Tourism seeks to expand local economies through a variety of tourism and recreational opportunities with an agricultural and open space emphasis.

Circulation Element

Goals CI-1 Comprehensive and Coordinated Transportation System and CI-2 Mode and User Equity deal with developing a fully connected grid circulation system, reducing road flooding, and planning for alternatives to automobile use.

Public Facilities and Services Element

Goal PF-1 Wastewater Management promotes policies regarding wastewater management and preventing nitrates from entering ground water.

Goal PF-3 Community Parks sets policies including providing 5 acres of park per 1,000 residents in towns and creating greenbelts to connect schools, residential areas, and parks.

Conservation Element

Goal CO-5 Water Resources includes policies to protect water quality and manage surface and groundwater for sustainable use.

Housing Element

Goal HO-3 Reduce Housing Constraints calls for developing plans to provide adequate infrastructure and public facilities to serve new housing.

The Dunnigan Community Plan complies with the land use designations prescribed in the Countywide General Plan.

Table 1. Zoning Consistent with General Plan Land Designations

General Plan Land Use Designation	Consistent Zoning Districts	General Description
Residential Rural (RR)	RR-2, RR-5	Single-family dwellings on estate size lots. (2 or 5 acre minimum)
Residential Low (RL)	R-L	Single family dwellings on urban size lots. (4 to 10 dwelling units per net acre)
Residential Medium (RM)	R-M	Single and multi-family dwellings on urban size lots and mobile home parks. (10 to 19 dwelling units per net acre)
Commercial General (CG)	C-G	Larger retail and other businesses that serve the everyday needs of the region, including grocery, restaurants, offices, and like uses.
Commercial General (CG)	C-H	Retail, commercial, amusements, and transient service uses (hotels/motels) appropriate to highway locations.
Commercial Local (CL)	C-L	Small local retail, service, and office uses that serve the everyday needs of nearby residents.
Industrial (IN)	I-L	Light industrial and service commercial businesses including those that serve the needs of agriculture.
Industrial (IN)	I-H	Heavy manufacturing and industrial uses that may create noise, odor, vibrations, or use hazardous materials.
Public/Quasi-Public (PQ)	PQP	Public services and facilities, including government offices, schools, libraries, and community infrastructure.
Parks and Recreation (PR)	P-R	Developed park facilities, play grounds, sports fields, and public pools.
Open Space (OS)	POS	Public open space, water bodies, agricultural buffer areas, and habitat.
Specific Plan (SP)	SP	Areas planned for future urban growth but which cannot be developed until detailed development standards as outlined in a specific plan are adopted.

Governmental Jurisdiction

Since the town is unincorporated, the Yolo County Board of Supervisors has the primary responsibility for providing most of the local government services, including planning and development regulations, review, and approval.

In addition to the County, several special districts are involved with shaping Dunnigan's future. The implementation of this plan will require a coordinated effort among these different public agencies. The Dunnigan County Service Area 11 (CSA 11) is a dependent special district that collects funds to install lighting at intersections that often become obscured by heavy fog. While currently providing only street lighting, CSA 11 could provide other services such as sewer, water, storm drainage, parking, parks and recreation, solid waste collection and ambulance service, among others. However, formation of a Community Service District would be preferable to serve new development.

The Dunnigan Water District distributes water from the Tehama-Colusa canal for irrigation to approximately 10,500 acres of agricultural land in the vicinity of Dunnigan. The district's water allocation contract is with the U.S. Bureau of Reclamation. The district does not currently have the infrastructure to serve additional non-agricultural lands but does provide water to some commercial businesses for landscaping and fire protection. A private company, California American Water, provides community water and wastewater services for the southern area of Dunnigan north of County Road 8.

Schools are provided to Dunnigan residents through the Pierce Unified School District (PJUSD). Children from the Dunnigan area are bused to schools in Arbuckle, about ten miles north of Dunnigan in Colusa County. The 2022-23 PJUSD Facilities Master Plan shows that 207 students originate from the Dunnigan area including 85 elementary school students. The district at one time operated an elementary school in Dunnigan, but that facility was closed because it was considerably more expensive to operate than busing the students to Arbuckle.

The Dunnigan Fire Protection District provides fire protection service to Dunnigan and the surrounding 105 square mile area. The district has about 24 volunteers including a fire chief, assistant chief, one captain, and two lieutenants. The general condition of all the equipment is good, though some of the individual units are quite old.

Process

The Dunnigan Community Plan builds on previous plans and was prepared in collaboration with the Dunnigan Citizen Advisory Committee (DCAC) and included a mailed community questionnaire and series of public meetings in Dunnigan between June 2022 and May 2023. The DCAC recommended approval of the plan at the February 2024 meeting.

2. The Community Plan Area

Located near the northern boundary of Yolo County, Dunnigan lies within the fertile Sacramento Valley between the uplands of the Dunnigan Hills to the west and the floodplain of the Sacramento River to the east. Interstate 5 runs through the center of Dunnigan and connects it to its closest neighbor, the unincorporated community of Arbuckle in Colusa County approximately eight miles to the north, and the communities of Zamora, Yolo, and the City of Woodland to the south.

Figure 1. Community Location

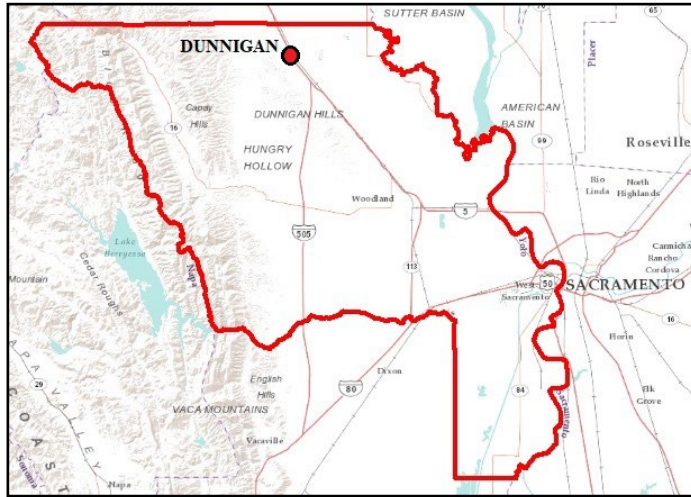

Community Boundary

The Dunnigan Community Plan focuses on the area within the Community Growth Boundary (CGB) of Dunnigan which contains approximately 840 acres along Interstate 5 in two discrete areas. The north and central parts of the community run roughly from County Road 2 at the north end to County Road 6 at the south end. The noncontiguous southern part of the community is located around County Road 8. The CGB serves to mark a clear separation between the urban development of the community and the productive agricultural land which surrounds the community on all sides.

The CGB is expanded modestly in this plan to include one area of existing residential development and the two areas identified in the 2030 Countywide General Plan (see Figure 2).

Figure 2. Community Boundary

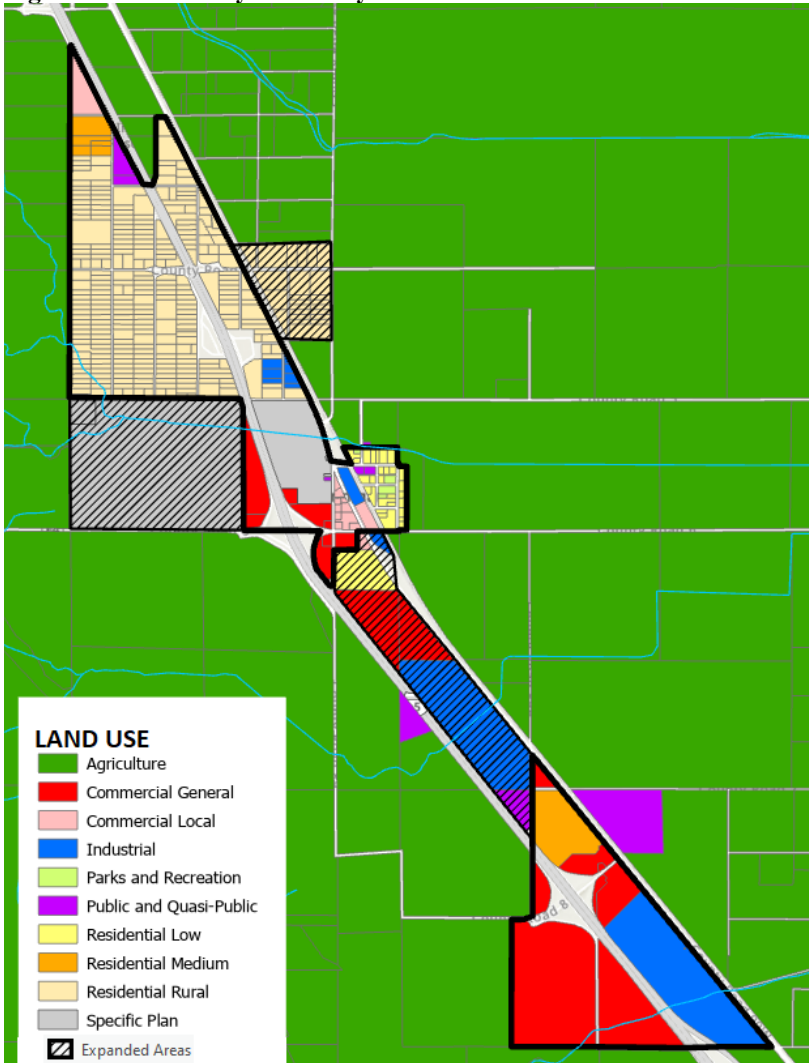

From north to south, these areas include:

- 60 acres of the original 1901 Yolo Hardwood Company’s subdivision between County Road 99 and County Road 89 is included within the CGB in recognition that, like the rest of the Hardwood Grove, this area consists of predominantly two to five acre lots in residential use.

The two growth areas identified in Policy CC-3.8 of the 2030 Countywide General Plan:

- 215 acres west of I-5 between County Road 5 and County Road 6 is included with a Specific Plan (SP) designation to be known as the West Dunnigan SP, which would provide a mix of parks, housing, and public services.
- 140 acres between I-5 and CR 99W from CR 6 to CR 7 is included to bridge the disconnected areas of Dunnigan along the Interstate 5 corridor with a mix of residential, commercial, and industrial uses.

Community Background

Dunnigan was originally founded under the name Antelope by a pair of settlers whose claim was washed out by the flooding of the Sacramento River. They decided to relocate well away from the floodplain at the town’s current location and the settlement grew, attracting an inn and drug store. When the railroad came through in 1876, the name was changed from Antelope to Dunnigan.

With access to the railroad and surrounded by farmland, Dunnigan became an agricultural service center. A failed scheme to commercially grow eucalyptus trees in the early twentieth century became the largest residential area in northern Yolo County when the wood lots of the Hardwood subdivision were later sold as homesites. When Interstate 5 was built in the 1960s, it divided the Hardwood subdivision from the Main Street area of town, though the interstate traffic has been seen as a source of potential economic development. The 2001 Dunnigan Community Plan focused on providing highway commercial services in the hopes of providing the town with jobs for the community and tax revenue for the County. Three expansion areas were identified, two of which have since been developed with a truck stop, farm equipment auction, and travel centers. Currently, close to half of the community is zoned for Highway Services Commercial.

Figure 3. Dunnigan population change

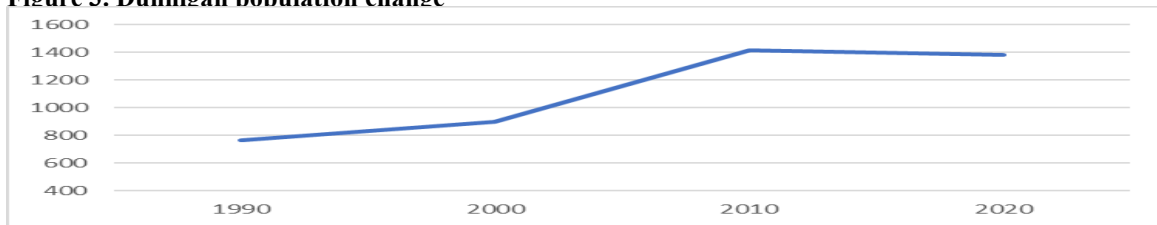

Dunnigan saw its largest population growth in the first decade of the 21st century when the number of residents increased from 897 in 2000 to 1,416 in 2010. According to Census data, the number of households increased from 189 to 504 during this period. Over the last decade, however, population has decreased. The 2020 Census reports that the population of Dunnigan has fallen slightly to 1,382 people and 484 households.

A Specific Plan prepared for the entire community around 2010 proposed to greatly expand the Community Growth Boundary. Had the plan been approved, it would have increased the footprint of the community by developing approximately 2,250 acres of farmland and building a minimum of 5,000 new homes. The Specific Plan was not able to balance the increase in population with providing local jobs and was ultimately withdrawn.

Without the Specific Plan, the community reverted to a version of the previous set of land uses contained in the 2001 Dunnigan Community Plan. In the interim, however, Yolo County had adopted the 2030 Countywide General Plan and some of the land use designations and corresponding zones used in the 2001 community plan are now obsolete. The update of the Dunnigan Community Plan addresses some of the changes in the community over the last 20 years.

3. Vision, Goals, and Implementation

Vision

The guiding vision for this community is to promote development that preserves the character of the town, enhances and maintains agriculture, and protects the natural environment.

Goals and Policies

The Dunnigan Community Plan consists of a Land Use Map, which illustrates the location for different kinds and intensities of land uses, along with community goals, policies, and programs. Goals are statements about the preferred condition the town is aspiring toward. Policies give direction for accomplishing these goals. Programs are implementation actions needed to make the plan come about.

Following is a compilation of the goals and policies for the Community Plan. They are included in this chapter to facilitate review by community members, Yolo County staff, and members of the development community. Further information on the intention and reason for these policies can be found in the chapters that follow. The bolded heading gives the relevant chapter's name and the italicized goals discussed in that chapter with the resulting policies numbered sequentially for each chapter.

Land Use Goals

Goal 1: Provide Dunnigan and the surrounding area with a wider variety of goods and services with a focus on infill development around the town center.

D-LU-1 Include the easternmost part of the Hardwood Subdivision between CR 99W and CR 89 within the Community Boundary with a Rural Residential land use designation.

D-LU-2 Development of the Town Center Specific Plan between Old Town and Interstate 5 shall require a Master Plan to include a mix of residential, commercial, public, and open space land uses.

D-LU-3 The two growth areas for Dunnigan described in the 2030 Countywide General Plan will be designated for a balanced mix of housing and job-providing commercial and industrial development. The area designated as the West Dunnigan Specific Plan shall require a Master Plan for a mix of residential, recreational, local commercial, and public land uses and include a future T/K-8 school site. The South Dunnigan growth area will include industrial, general commercial, open space, public, and a limited amount of residential land uses.

D-LU-4 New development shall pay its fair share of providing additional public services needed to accommodate such development.

D-LU-5 Target Old Town and the Hardwood Grove for 7 acres of parks and sports fields to meet the General Plan requirement of 5 acres of neighborhood parks per 1,000 residents.

D-LU-6 Development at County Road 8 will continue to support highway-oriented commercial land uses that provide economic opportunities for the community.

Agriculture Goals

Goal 2: Support farmland conservation and agricultural support services

D-AG-1 Agricultural lands surrounding Dunnigan shall be protected from the encroachment of urban development. Land uses outside the Community Growth Boundary shall be limited to agriculture, uses that are compatible with agriculture, or public/quasi-public uses.

D-AG-2 Conservation of farmland in northern Yolo County shall be fostered through the continued support of Williamson Act contracts and promotion of permanent conservation easements. The Board of Supervisors may consider appropriate areas of prime farmland within two miles of the Dunnigan Community Boundary to be designated eligible for agricultural mitigation under the Agricultural Conservation and Mitigation Program Ordinance. This consideration shall apply only for projects north of the County Road 13 alignment.

D-AG-3 Encourage agricultural support uses near the community along Interstate 5 on small and irregularly shaped agricultural parcels. Agricultural support uses could include farm machinery sales and repair, agricultural processing facilities, product or equipment warehousing, and farm supply stores.

Transportation Goals

Goal 3: Provide a safe and efficient circulation network for Dunnigan.

D-TR-1 Street sections for residential streets should have a 50-foot right-of-way and 32 feet of pavement from curb to curb, and five-foot sidewalks.

D-TR-2 Improve access to the southern end of the Hardwood Grove by extending and improving County Road 5 to provide a complete street connection between County Road 88 and County Road 89.

D-TR-3 Development of the West Dunnigan Specific Plan area shall provide a road between County Roads 5 and 6 by extending County Roads 88A, 88B, or 88C.

D-TR-4 Streets shall be arranged on a grid pattern to provide access and connectivity.

D-TR-5 Strict enforcement of keeping roads clear of parked vehicles and encroachment into the public right-of-way.

D-TR-6 Development of the Town Center Specific Plan will include measures to improve safety at the intersection of County Roads 89, 99W, and Main Street.

Environment and Public Service Goals

Goal 4: Protect natural resources and community health and resiliency.

D-EPS-1 To mitigate noise and potential health hazards due to poor air quality along Interstate 5, the County shall require a minimum 300-foot setback from residential development from the right of way for Interstate 5. All development along Interstate 5 is encouraged to provide vegetative screening to provide a visual and noise buffer.

D-EPS-2 To protect riparian habitats and prevent risk to property, the County shall enforce a 100-foot development setback along Buckeye Creek, Bird Creek, Dunnigan Creek and Azevedo Draw.

D-EPS-3 Landowners within the Hardwood Grove should maintain a 100-foot defensible space around their homesite clear of dense eucalyptus groves and thin eucalyptus on undeveloped lots. Where eucalyptus has been removed, replace with oaks and other native tree species.

Goal 5: Provide the level of public services desired by the residents at an equitable cost.

D-EPS-4 The County shall explore private and public funding sources for providing community water and wastewater service.

D-EPS-5 The County shall work with the Dunnigan Fire Protection District to improve emergency access and fire prevention through road additions and improvements, water storage and distribution, eucalyptus thinning, and trash abatement.

D-EPS-6 Establish a Sheriff's substation and ambulance service in the community to shorten response times.

D-EPS-7 Health care and emergency services should be planned to precede or coincide with the increase in the demand beyond current capacities as a result of development.

D-EPS-8 The County shall ensure that new residential subdivisions within the Pierce Unified School District provide for additional student population with a focus on establishing a local school in Dunnigan to serve the community and neighboring region.

Implementation

Implementation of the Dunnigan Community Plan depends on both public and private participants. There are many challenges to revitalizing a small, unincorporated town, including the identification of funding for infrastructure improvements, phasing of improvements, and the coordination of multiple responsible agencies. Public expectations vary, and there are often competing interests. Community building occurs one step at a time and adoption of this Community Plan will not result in immediate change. The process does not end with the adoption of this document and it is important to continue with the steps necessary to bring about the vision of the plan. Periodically, it is desirable to reexamine the Community Plan's goals; the plan is intended to be a living document that can be changed and updated as local conditions change.

Implementation Programs

1. The County will revise its zoning map to reflect the land use designations of this community plan (see Exhibit A).

Responsible Agency/Department: Planning
Funding: SALC Grant
Timing: Included with adoption of Community Plan

2. Development of the Specific Plan areas shall require installation or contributions toward communitywide water and wastewater systems. The County shall continue to pursue sources of funding to provide community water and wastewater systems for existing development. If community water and sewer systems are created, the County will work with public and private interests to determine the best systems for managing and maintaining these systems, whether that be a creation or expansion of a Community Service District or a State regulated business such as California American Water.

Responsible Agency/Department: Planning, Environmental Health, Natural Resources, LAFCO
Funding: County General Fund, Grants, Private
Timing: Ongoing

3. The County shall prioritize an Emergency Access and Fire Prevention Plan for the Hardwood Grove area of the community.

Responsible Agency/Department: Planning, Public Works, Dunnigan Fire Protection District, Office of Emergency Services
Funding: County General Fund, Grants
Timing: 2027

4. The County shall identify and pursue funding sources to implement an Emergency Access and Fire Prevention Plan for the Hardwood Grove area of the community.

Responsible Agency/Department: Planning, Public Works
Funding: County General Fund, Grants
Timing: 2028

5. The County shall pursue Green Means Go grant funds from SACOG to improve traffic safety at the intersection of Main Street and County Roads 99W and 89.

Responsible Agency/Department: Planning, Public Works
Funding: County General Fund, Grants
Timing: 2027

6. The Dunnigan Citizen Advisory Committee will undertake an annual review and evaluation of implementation of this plan.

2024 Dunnigan Community Plan

Responsible Agency/Department: Dept. of Community Services
Funding: County General Fund
Timing: Annual

Figure 4. Dunnigan Land Use Map

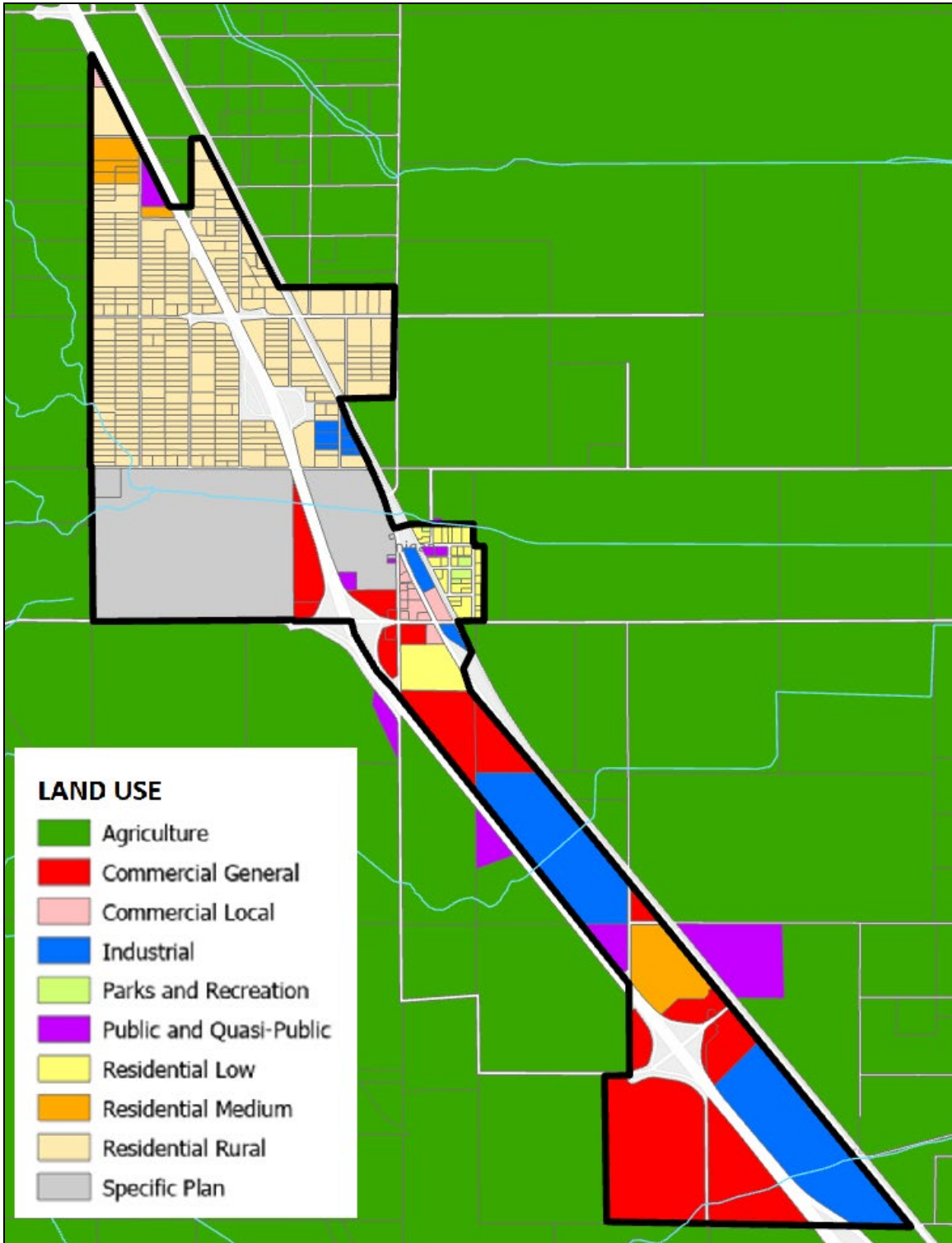
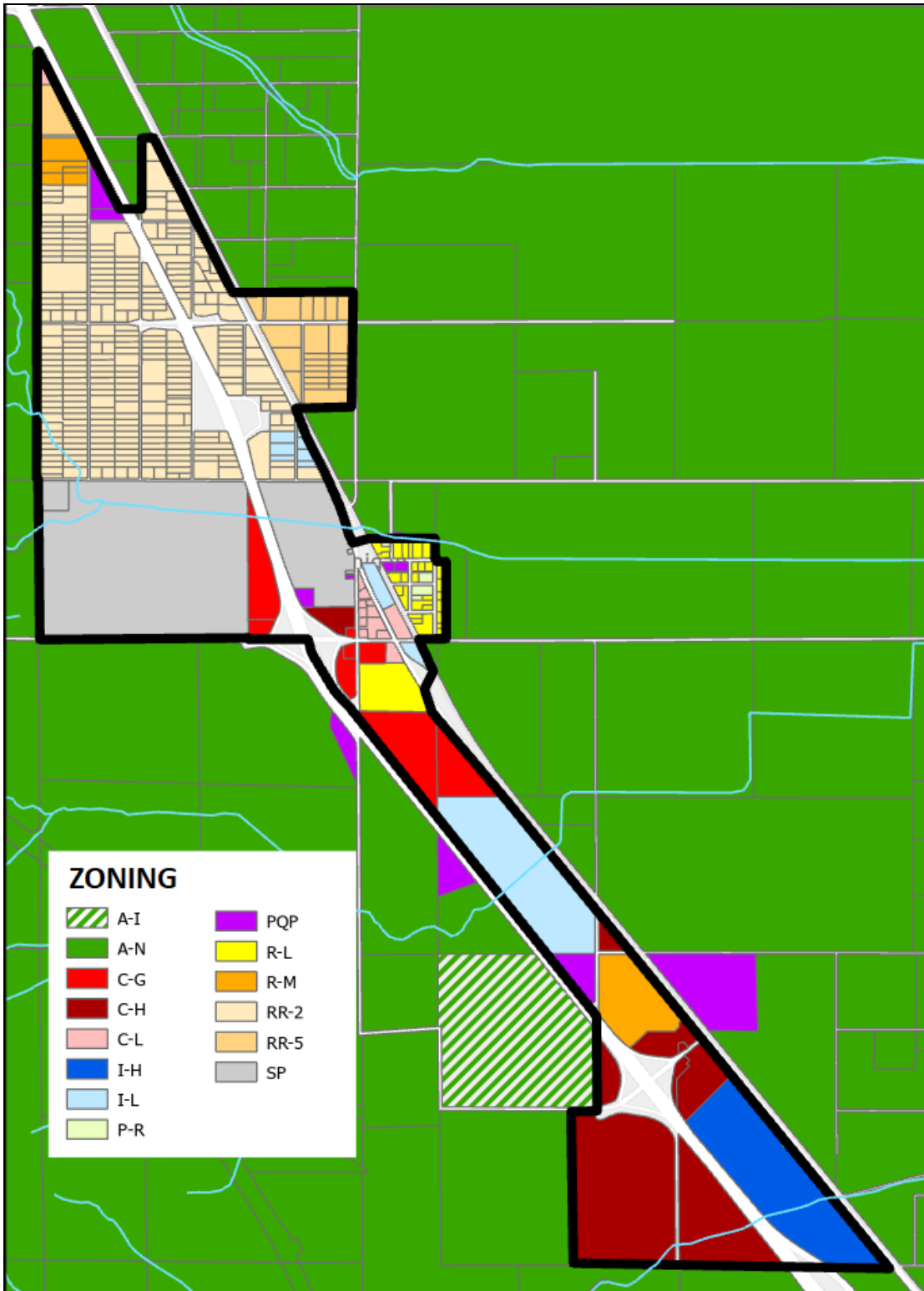

Figure 5. Dunnigan Zoning Map



4. Land Use

Existing Land Use Conditions

There are two important features, which make Dunnigan different from other small unincorporated towns in Yolo County. First, most of the community's residents live in the Hardwood Subdivision, also known as the Hardwood Grove, which was originally subdivided as woodlots devoted to growing eucalyptus trees. When it was recognized that these trees had little commercial value, the woodlots were sold as homesites, though the lots were not oriented to support residential use and lack adequate roads and infrastructure.

Second, the town is divided by Interstate 5, the major north-south transportation corridor in this part of the State. Thus, unlike other Yolo County towns which have a compact form, utilizing a traditional grid street pattern around a town center, Dunnigan consists of three discrete areas strung along the interstate: the northern area which includes the Hardwood Grove north of County Road 5, the central area which consists of Old Town at County Road 6, and the southern area which includes Country Fair Estates Mobile Home Park, Pilot Truckstop, and other highway-oriented commercial development at County Road 8.

Most of the residential development is in the Hardwood Grove area of northern Dunnigan. It consists primarily of one-acre lots on individual wells and septic systems. As mentioned above, this area was originally anticipated for timber production rather than residential development and provides challenges to access, circulation, water quality due to the density of individual well and septic systems, and fire concerns due to the remaining dense eucalyptus stands. At the northernmost end of this area is the Campers Inn Mobile Home and RV Park.

The central area of Dunnigan is the historic Old Town area on the east side of Interstate 5. The original 1876 plat for the town covered approximately 35 acres bounded by the Northern Railway on the west with Main Street at the north, Lincoln Street at the south, and Second Street on the east side. The Union Church of Dunnigan, also known as the Dunnigan Community Church, is the only historic public building still standing in Dunnigan. The Gothic revival church was completed in 1894 and registered as a National Historic Place in 2003.

Main Street is the site of the fire station, post office, and a small general store. The only community park, a half-acre plot with a playground, half-court basketball area, and portable toilets is located here. Most commercial development in Old Town, however, is at the intersection of County Road 6 and County Road 89 including two gas stations, a convenience store, a fast-food restaurant, and a motel. The 2001 Dunnigan Plan identified the approximately 54-acre parcel between the Old Town and I-5 as an expansion area to serve non-truck related highway services, but the area has remained undeveloped as this type of development has been drawn to the CR 8 interchange to the south.

The southern area of Dunnigan at County Road 8 has seen the most development recently with a 90-acre equipment auction, a truck stop, two gas stations, and four fast-food and one sit-down restaurants. Another truck stop on the west side of I-5 is currently being permitted. Country Fair Estates, a 174-site mobile home park predates the other development at this location by approximately a decade and a private water and wastewater utility owned by California American Water serves the residences and commercial uses north of CR 8.

The town of Dunnigan is surrounded by agricultural land. Much of this land is under Williamson Act agreement contracts. The Williamson Act provides a property tax reduction to farmers who agree to preserve their land in agricultural use.

Land Use Goals

Goal 1: Provide Dunnigan and the surrounding area with a wider variety of goods and services with a focus on infill development around the town center.

The community survey conducted for the plan found that many residents are dissatisfied with the amount of goods, services, and recreational opportunities available in Dunnigan. When asked their preferred non-residential land uses for the community, residents responded as follows ranked from most preferred to least: Local Businesses, Parks/Recreation, Agricultural Industry, Manufacturing, Highway-oriented Businesses, and Professional Offices. Local businesses that most respondents wanted to see were grocers and sit-down restaurants followed by pharmacy/clinics, hardware stores, and other retail. Parks, recreation centers, and gyms were the most requested recreational land uses followed by a pool, trails, ballfields, and dog parks.

Table 2. Dunnigan Zoning Area Comparison

Zoning	Current Acreage	Proposed Acreage	Current % of Community	Proposed % of Community
Rural Residential	345	410	41%	33%
Low Density Residential	18	171	2%	14%
Medium Density Residential	64	50	8%	4%
Highway Commercial	362	188	43%	15%
General Commercial	0	102	0%	8%
Local Commercial	25	51	3%	4%
Heavy Industrial	19	90	2%	7%
Light Industrial	3	94	0.5%	7%
Public/Quasi-public	4	39	0.5%	2%
Parks and Recreation	0	8	0%	1%
Open Space	0	57	0%	5%
TOTAL	840	1260	100%	100%

As seen on Table 1. Dunnigan Zoning Area Comparison, 43% of the Community is zoned for Highway-Serving Commercial (C-H). Although, C-H does permit grocery stores and various types of restaurants and retail, the zoning implies and facilitates uses more likely to be used by interstate travelers such as truck stops, large motels, and fast-food restaurants. Thus, developers have focused on these types of uses rather than more community serving establishments. In particular, C-H zoning around the town center at County Road 6 is in opposition to the community desire not to have heavy truck traffic through the community center. The Community Plan will retain the existing C-H zoning at County Road 8, but rezone C-H at County Road 6 to General Commercial (C-G) which permits the existing gas station and fast food uses while C-H will be retained for the existing motel development.

The Community Plan seeks a better balance of land uses by providing more land for parks and public services and increasing the number of employers with an increase in non-highway services commercial and industrial land uses which typically require more employees. The number of acres available for residential development is also increased based on the potential development of the Specific Plans. The actual development of Low Density Residential development as well as any future potential development of Medium and High Density Residential land uses is dependent on the construction of water and wastewater services.

The approximately 54-acre parcel between I-5 and Old Town Dunnigan currently zoned for highway-services commercial would receive a Specific Plan (SP) designation to include a broader variety of land uses appropriate for the site. The area will be identified as the Town Center Specific Plan (TCSP) and allocate approximately 6 acres of land designated Public for infrastructure such as a wastewater treatment, 12 acres of land designated Open Space to protect Dunnigan Creek, 18 acres of Residential land use, 12 acres of General Commercial, and 6 acres of Local Commercial land use (see figure 6).

Figure 6. Potential Land Use Designations for the Town Center Specific Plan

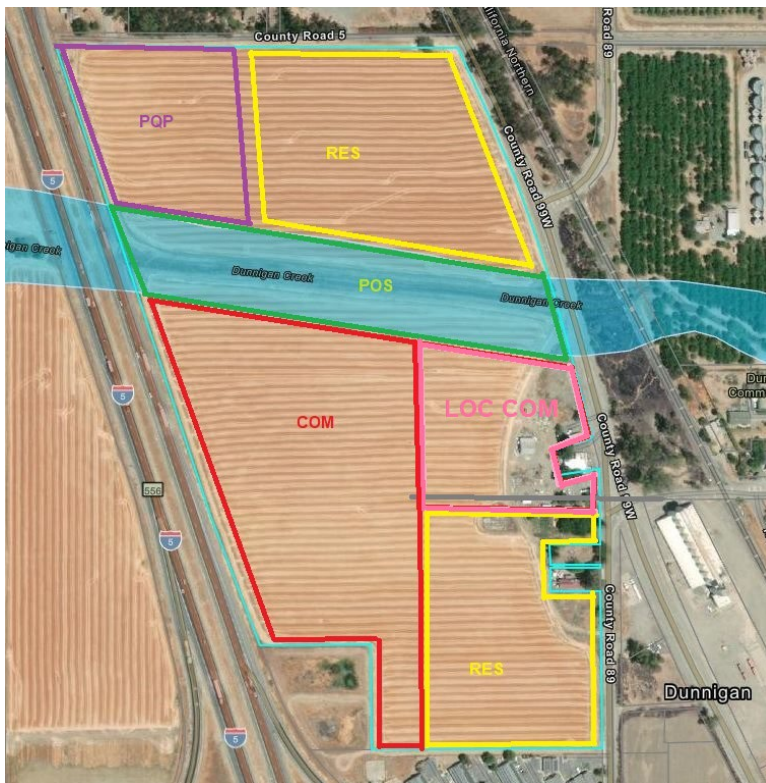

Currently, Dunnigan has no land zoned for Parks and Recreational use despite the 2030 Countywide General Plan’s policy that communities provide 5 acres of parks per 1,000 residents. The only park area currently provided is the half-acre Community Park with a playground and half of a basketball court on County Road 89 designated for Public and Quasi-public land use. At

current population levels, the community should have at least six acres of park and recreation designated land. The existing park will have its land use designation changed to Parks and Recreation (PR) and the County has initiated a discussion with the Bureau of Land Management to purchase three acres of land at 1st and Hays Streets for recreation field. Other high priority locations to consider for new parks areas within the Hardwood Grove or a dedication within the West Dunnigan Specific Plan area discussed below.

Figure 7. Potential Land Use Designations for the West Dunnigan Specific Plan

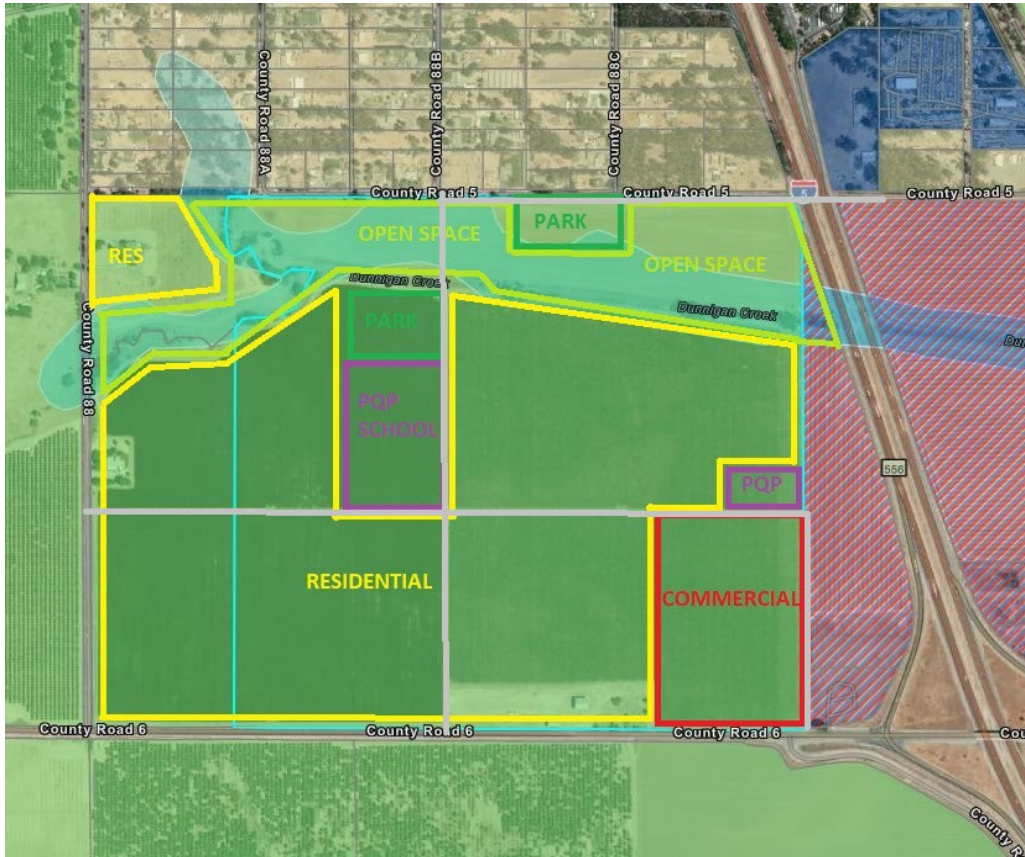

The West Dunnigan Specific Plan (WDSP) has been designated to provide land for community growth and services. The three parcels totaling approximately 215 acres would help fill in the gap between northern and central Dunnigan. Approximately 135 acres would be designated for Residential use with about 20 acres of Local Commercial use in the southeast corner closest to I-5. Approximately 15 to 20 acres of land designated for public uses would be available to provide for community water, a school site or other community services. At least 5 acres of recreational parks should be provided for the increase in population. The WDSP would include approximately 40 acres of Open Space along Dunnigan Creek for stormwater detention and trails. (See Figure 7). As discussed in the Health and Safety Chapter, this limited growth would make the provision of community water and wastewater services more feasible as well.

The third highest preferred land use identified by the community is agricultural industry land uses. Currently, about 22 acres or 2.5% of the community is zoned for Industrial uses. These include the silo facility at Main Street along CR 99W, and the scrapyards north of CR 5. The parcel identified as ‘Expansion Area 3’ in the 2001 Dunnigan Plan which was developed by Richey Brothers Auctioneers, was originally designated as Agricultural Industry, but during the removal of the Dunnigan Specific Plan in 2017, the land received a zoning for Highway Services Commercial. Although farm equipment sales are permitted with a Site Plan Review permit in the C-H zones, Heavy Industrial (I-H) zoning permits the repair and sales of heavy equipment by right and it would be more appropriate to change this parcel’s land use designation to Industrial. Approximately half of the expansion area connecting central and southern Dunnigan is designated for new industrial use. The Agriculture chapter also identifies agriculturally designated parcels adjacent to the interstate and outside the community that are appropriate for agricultural industrial and other agricultural support uses.

As discussed in the following chapter on agriculture, there continues to be a high demand for agricultural processing facilities and other agricultural support uses in Yolo County. In order to focus this type of development near highway access and existing communities, the Dunnigan Community plan has identified the narrow strip of land between I-5 and CR 99W for industrial and commercial land use as an expansion area.

Economic Development

Industrial and commercial development, as called for by the proposed Dunnigan land use plan, can have significant economic and fiscal impacts on the surrounding area. First, such development will create jobs for local residents. Second, some of the income earned by local residents will be spent in the area, thus increasing the level of economic activity. Finally, commercial development typically generates substantially more tax revenues for local governments than it costs to provide public services for such uses.

One of the goals of this plan is to balance the development of new housing opportunities in the Dunnigan area with the availability of jobs in the area. Although there is a discrepancy between the number of residents and job availability, it is important to note that a higher percentage of Dunnigan residents are of retirement age with 33% of residents aged 65 or greater. This combined with the 21% of the population under the age of 18 means that less than half of the population is within the age range most likely to be considered part of the labor force. This is an important consideration when balancing local jobs with the available labor force.

Economists use multipliers to quantify the total economic activity that results from a given economic action. For example, if one spends a dollar in a doughnut shop, that dollar provides the baker with the opportunity to spend a dollar on shoes (or any other commodity). Various studies cite spending multipliers ranging from 1.5 to as high as 3.5, though a recent study cites 1.9 as a conservative figure. This suggests that for every dollar of wages, another 90 cents worth of economic activity will result.

Finally, one must consider the tax revenues generated by commercial development versus the cost of providing public services such as police and fire protection, or possibly water and sewer service.

The largest contribution of commercial development will likely come from retail sales taxes, property taxes, and in case of motels and hotels, transient occupancy taxes.

Typically, when revenues from commercial development are weighed against the cost of public services needed by the development, most commercial development is shown to be fiscally beneficial. Commercial development will need additional levels of police and fire protection; however, such uses generally require fewer parks, schools, and personal services than residential development. Combined with the significantly large revenues generated by commercial development, this fact generally causes commercial development to generate more revenues than expenses.

It is important to note that public services may also contribute to revenue generation. For example, the presence of a school in Dunnigan would improve the housing market, enhance the tax base, and help employers hire and retain local employees.

5. Agriculture

Existing Agriculture Conditions

Agriculture has played, and continues to play, an important role in the economy and development of the Dunnigan area. Almonds are the main crop grown around the community of Dunnigan with walnut orchards, rice, wheat, tomatoes and other fruits and vegetables also grown on the surrounding farms (Figure 5).

Figure 8. 2021 Crop Permits by Type

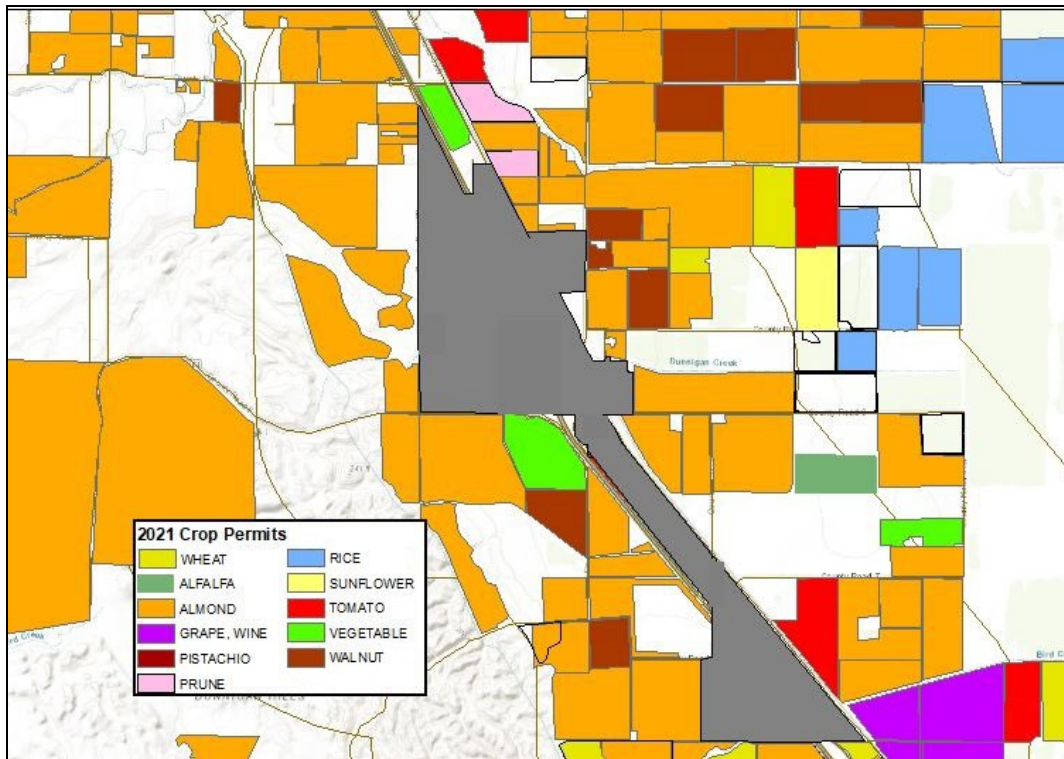

Soils

The U.S. Department of Agriculture, Natural Resources Conservation Service has developed a system for placing soils in land capability classes. The system uses a scale from I to VIII, with Class I having the most desirable characteristics and Class VIII having the least desirable characteristics. Soils Classes I and II are considered prime agricultural land. Class I soils are very deep and well drained, with moderately fine texture on nearly level topography. Class II soils are also prime agriculture land but may have minor problems, such as inferior drainage, too fine a texture, or a slight slope (between 0% and 2%). Class III and Class IV soils have additional restrictions (slopes, drainage, texture), but may still be suitable for agriculture. Class V and VI are generally unsuitable for farming because of excessive slopes or rocky soils.

In an effort to monitor the amount and productivity of the State's farmlands, the State of California Department of Conservation has mapped soils that it considers to be "prime" and of "statewide importance." Almost all the soils surrounding Dunnigan are considered "prime" on the State Important Farmland Map.

Much of the land around Dunnigan, in particular east of CR 99W and west of the Tehama-Colusa Canal, are part of agricultural preserves and have a Williamson Act Land Use Agreement with the County. Although these contracts provide protection for farmland at the decadal level, perpetual conservation easements are rather limited for the area. Currently, the Wildlife Heritage Foundation holds two conservation easements; the Dunnigan Agricultural Easement which includes approximately 247 acres west of CR 89 and south of Buckeye Creek; and the Ridge Cut Easement including approximately 200 acres west of the Colusa Basin Drainage Canal. Additionally, over 2,000 acres along the Colusa Basin Drainage canal east of Dunnigan is held federally by the US Natural Resources Conservation Service.

As discussed in the Yolo County Agricultural Conservation Priority Plan (April 2023), Yolo County has been very successful in preserving agricultural land by protecting agricultural land from conversion to nonagricultural uses through various land conservation and mitigation strategies including zoning with minimum parcels sizes that are large enough to sustain viable agriculture and discouraging land division for residential development outside of communities.

Agriculture industry is supported in the Dunnigan region as well. The Vann Brothers operate an almond huller at CR 8 west of I-5. Ritchie Bros Auctioneers sell farm equipment, truck tractors and other heavy equipment at their 90-acre facility at CR 8 on the west side of I-5.

Agriculture Goals

Goal 2: Support farmland conservation and agricultural support services

D-AG-1 Agricultural lands surrounding Dunnigan shall be protected from the encroachment of urban development. Land uses outside the Community Growth Boundary shall be limited to agriculture, uses that are compatible with agriculture, or public/quasi-public uses.

D-AG-2 Conservation of farmland in northern Yolo County shall be fostered through the continued support of Williamson Act contracts and promotion of permanent conservation easements. The Board of Supervisors may consider appropriate areas of prime farmland within two miles of the Dunnigan Community Boundary to be designated eligible for agricultural mitigation under the Agricultural Conservation and Mitigation Program Ordinance. This consideration shall apply only for projects north of the County Road 13 alignment.

Farmland Conservation

The conversion of farmland to non-agricultural uses is the biggest threat to farms and agriculturally viable farmland. Yolo County has prioritized the protection of farmland through strict zoning and support of Williamson Act contracts and farmland conservation easements. Another threat to continued agricultural viability is the encroachment of urban uses that may interfere with agricultural operations or are incompatible with the noise, dust, and chemical use associated with agricultural operations. Residents next to agricultural operations may complain

and demand restrictions upon the agricultural operations to reduce nuisance impacts. Yolo County has a right-to-farm ordinance that provides protection for agricultural uses against such complaints. To minimize potential conflicts between agriculture and urban uses, the General Plan (Policy LU 2.1) requires a buffer zone between urban and agricultural lands outside the Community Growth Boundary

The County Agricultural Conservation and Mitigation Program Ordinance (Sec. 8-2.404) generally directs conservation easements for agricultural mitigation to areas within two miles of the Sphere of Influence for an incorporated city within the county or within two miles of the community boundary of Esparto. Priority conservation areas which allow mitigation at a 1:1 ratio for prime farmland are located within a quarter mile of the above-mentioned communities and much of the area between Davis and Woodland.

Figure 9. Areas designated for agricultural mitigation

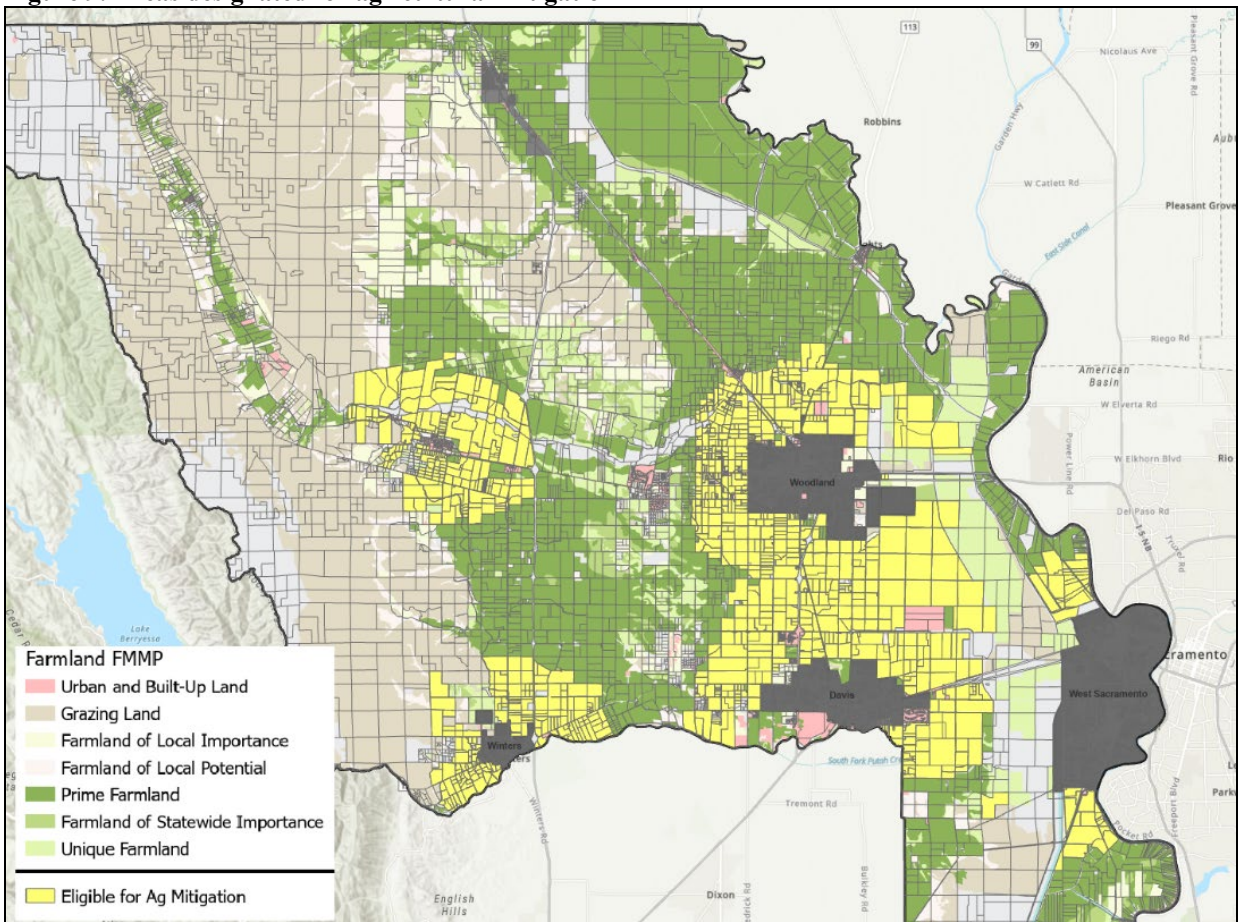

Sec. 8-2.404(d)(1) of the Zoning Ordinance allows the Board of Supervisors to adopt a resolution designating other areas that are predominantly designated as prime farmland and/or under threat of conversion to non-agricultural uses as eligible for agricultural mitigation. As shown in Figure 10 below, much of the area within two miles of Dunnigan’s community boundary is designated as

Prime Farmland by the California Farmland Mapping and Monitoring Program and could be eligible for agricultural mitigation areas as well. This designation would encourage preservation of agricultural lands in the northern portion of the County which is not currently designated as qualifying for agricultural mitigation under the County’s ordinance. To more directly link conservation of farmland with future development of Dunnigan, the County should consider only allowing agricultural mitigation in the area around Dunnigan for projects in the northern part of the County (specifically projects that convert agricultural land north of County Road 13).

Figure 10. Potential agricultural mitigation areas around Dunnigan

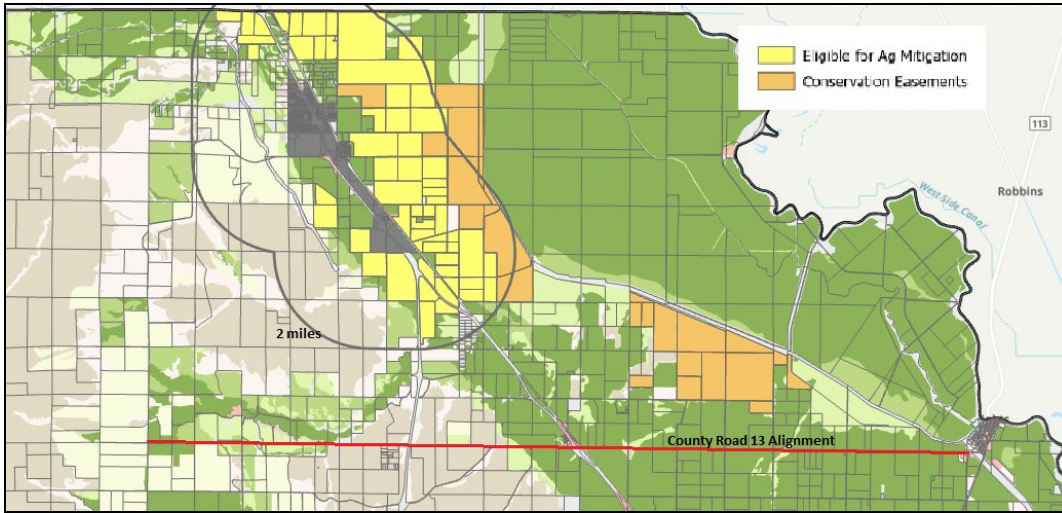

Agricultural Support and Industry

D-AG-3 Encourage agricultural support uses near the community along interstate 5 on small and irregularly shaped agricultural parcels. Agricultural support uses could include farm machinery sales and repair, agricultural processing facilities, product or equipment warehousing, and farm supply stores.

General Plan Policy LU-2.2 advocates for additional agricultural commercial and industrial zoning where appropriate. This is aligned with the 2020-2025 strategic goal to increase the development potential of the freeway corridors through Yolo County. The County has identified easily accessible parcels within a quarter mile of I-5 and I-505 between five and twenty acres in size as potentially developable for agricultural support industry and commercial services. Five acres is the minimum size for Agricultural Industrial zone (A-I) and 20 acres is generally seen as too small to farm in Yolo County. Additionally, parcels abutting the highway may be irregular in shape making them difficult to farm. The parcels highlighted in Figure 7 meet the location requirements and are close enough to Dunnigan to provide additional employment opportunities to the community.

Figure 11. Parcels suitable for potential I-5 corridor development



There continues to be a high demand for agricultural processing facilities and other agricultural support uses in Yolo County. To encourage these uses near rural communities that need local employment opportunities, applying the Agricultural Industrial (A-I) zone to other parcels near local communities and with easy access to Interstates is a strategic goal of the County. The gap between the southern and central areas of Dunnigan along CR 99W could be a good location to facilitate employment generating capacity with a focus on agricultural commercial and industrial land uses. This area was retained in the C2030 Countywide General Plan for expansion of the community and has been designated mainly for commercial and industrial land uses. Agriculturally related businesses should be encouraged to locate here. Similarly, the Vann Brothers nut hulling facility on the west side of the County Road 8/I-5 interchange will be zoned to A-I in recognition of the agricultural processing facility.

Dunnigan has succeeded in developing highway commercial services at County Road 8 since the 2001 Dunnigan Plan identified the area as an expansion area that was designated and zoned for highway services. It has since been developed with two travel centers, a gas station, five fast food restaurants. An additional 100 acres is zoned for similar development on the west side of I-5 and has another truck stop and travel center development pending.

The plan from 2001 also included an expansion area for agricultural industry uses at the site of the Ritchie Brothers Auctioneers. County Road 8 has also become the headquarters of the Vann

Brothers almond huller business which lies on a 140-acre parcel just west of the intersection with the interstate. Although, agricultural support businesses may be allowed on parcels designated for agriculture, the County would like to focus the more intensive developments to smaller parcels that are harder to cultivate and are close to the interstate and communities where employees might live. Identifying parcels between 5 and 20 acres within a half mile of Interstate 5 the County can focus attention on the use of these parcels by zoning them to A-I.

6. Transportation

Existing Transportation Conditions

While the County maintained road system in the Dunnigan area has been established in a grid pattern, Interstate 5 (I-5) bisects the town diagonally from the northwest to the southeast creating a number of challenges. Interstate 5 is the major north-south highway that links the west coast of the United States from Canada to Mexico. On average, approximately 35,000 vehicles travel I-5 through Dunnigan.

Two interchanges from I-5 provide the principal access into Dunnigan. The County Road 8 interchange provides access to the southern part of Dunnigan, and the County Road 6 interchange provides access to the central part of Dunnigan. County Road 4 which provides access to northern Dunnigan does not connect directly to I-5. Although the Dunnigan Safety Rest Area is located adjacent to the Hardwood Grove in northern Dunnigan, approximately 0.7 mile north of the CR 6 interchange, neither the northbound nor southbound rest stop allows access beyond the immediate rest stop facilities.

Figure 12. Access within the Hardwood Grove

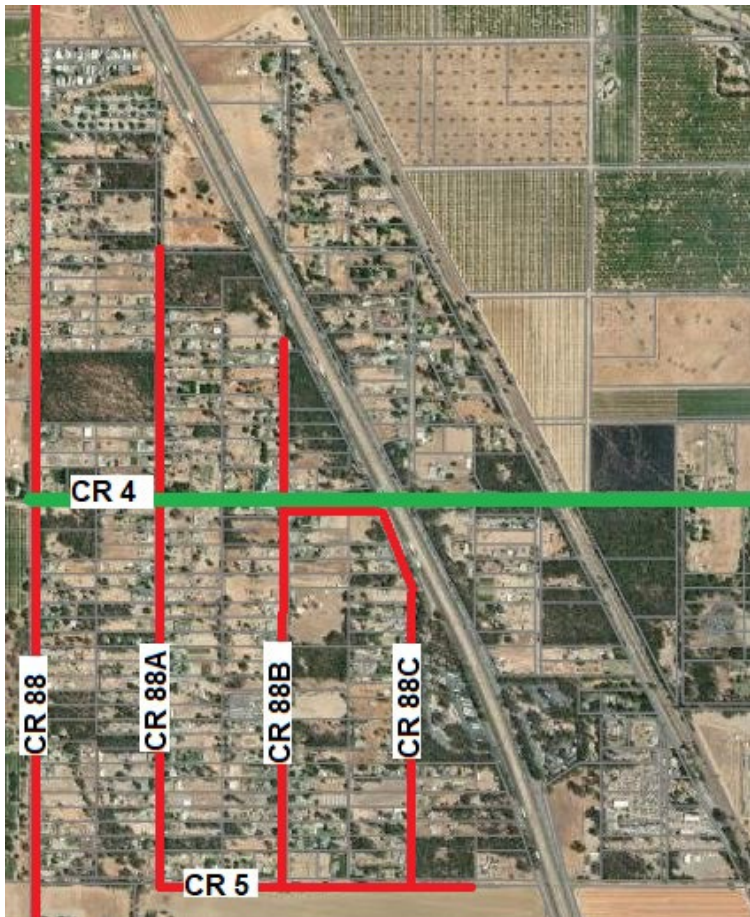

The Hardwood Subdivision was originally intended to create commercial woodlots and was not designed to provide appropriate access and circulation for the approximately 300 acres of rural residential development that now characterize the Hardwood Grove. The northern part of Dunnigan can only be accessed by CR 4 which connects to CR 88 at the west end and passes over I-5 to connect to CR 99W to the east. Three roads (CR 88A, 88B, and 88C) provide north-south access. South of CR 4, CR 88A and CR 88B run a half mile to CR 5. County Road 88C parallels CR 4 east back toward I-5 before turning south to reach CR 5 running for approximately 3,000 feet. County Road 5 runs east from CR 88A to a dead-end just past CR 88C creating a cul-de-sac. Although no right-of-way or easements exist, two dirt alleys run behind the 100-foot wide by 435-foot long lots in the southern half of the Hardwood Grove. One alley is located between CR 88A and 88B and the other between CR 88B and 88C.

The three north-south roads (88A, 88B, and 88C) of the Hardwood Grove originally platted for the woodlots do not meet the County minimum width for residential streets. Furthermore, the roads may run over a mile between cross streets. Only County Road 4 provides access and egress to both the east and west by connecting to County Road 88 and by passing over I-5 to County Road 99W. Two freeway rest stops are located on the east and west side of I-5 adjacent to the Hardwood Grove area.

North of County Road 4, only two roads run north-south: CR 88A extends approximately 1,700 feet before reaching a dead-end and CR 88B extends approximately 1,000 feet before ending in a turn-around adjacent to I-5. There is no east-west access north of County Road 4.

Except for County Road 4, county-maintained streets within the Hardwood Grove do not comply with the minimum design standards for local residential streets. County design standards require 58 feet of right-of-way and 36 feet of paved drive lanes. The streets in the Hardwood Grove have only 40 feet of right-of-way and barely 20 feet of paved roadway with drainage ditches along each side of the roadway. Where driveways intersect the streets, private culverts of varying sizes and degrees of maintenance connect the drainage ditches. Private alleys and streets are not paved. All these conditions create a high level of concern about effective evacuation routes and emergency vehicle access for the Hardwood Grove.

County Road 99W runs diagonally through Dunnigan, roughly parallel to Interstate 5 and adjacent to the Southern Pacific railroad tracks. Thus, a few intersections of County roads and County Road 99W occur at non-perpendicular angles. In some cases, this creates sight distance problems for motorists attempting to cross or turn at these intersections. This alignment can also create confusion for visitors who may not be familiar with the area. Of particular concern is the intersection of Main Street, County Road 99W, and County Road 89.

Alternative transportation is not currently available in Dunnigan. Although the Southern Pacific railroad offers freight transportation through the Dunnigan area, the nearest passenger rail service is the Amtrak station in Davis. Yolobus has provided service between Woodland and Dunnigan in the past, but transit service is no longer available to Dunnigan. Finally, there are no established bike routes in the Dunnigan area.

Transportation Goals

Goal 3: Provide a safe and efficient circulation network for Dunnigan.

D-TR-1 Street sections for residential streets should have a 50-foot right-of-way and 32 feet of pavement from curb to curb, and five-foot sidewalks.

Hardwood Grove Access

D-TR-2 Improve access to the southern end of the Hardwood Grove by extending and improving County Road 5 to provide a complete street connection between County Road 88 and County Road 89.

D-TR-3 Development of the West Dunnigan Specific Plan area shall provide a road between CR5 and CR 6 by extending CR 88A, 88B, or 88C.

D-TR-4 Streets shall be arranged on a grid pattern to provide access and connectivity.

Figure 13. Hardwood Grove Potential Access Improvements (yellow lines)



A major concern of the community is the limited access and poor condition of the roads in the northern part of Dunnigan. The County standard for local residential streets is 58 feet of right-of-way with 36 feet of pavement from curb to curb and separated sidewalks on either side of the street. Roads in the Hardwood Grove which were not designed for residential use fall far short of this standard with only 40 feet of right-of-way provided and a substandard road width that is impacted by the lack of a comprehensive stormwater drainage system.

California Fire Code sets a maximum length of 1,320 feet for a dead-end road serving parcels between parcels 1 to 5 acres in size regardless of the number of parcels served. Currently, CR 88A north of CR 4 exceeds the maximum dead-end road length. One means for the dead end to be remedied is to require a through road for public safety between CR 88 and 88A as part of an expansion of the Campers Inn development at the northern end of the Hardwood Grove.

There has been much discussion about extending CR 5 to provide better access to the homes south of CR 4, but it is difficult to find a feasible solution. Extending County Road 5 east to CR 99W would need to be elevated to get over the interstate and although there is existing right-of-way at the west end of CR 5 to connect it to CR 88, extending CR 5 here would require a bridge to cross over the creek that drains into Dunnigan Creek. Either of these options would be quite expensive and the County would need to pursue a grant to be able to complete construction. Other proposed alternatives include an emergency access gate to the southbound safety rest stop on I-5 or an extension of CR 88B or CR 88C as part of the development of the West Dunnigan Specific Plan.

Implementation Actions 4 and 5 call for the County to complete an Emergency Access and Fire Prevention Plan for the Hardwood Grove. This plan should look at acquiring right-of-way to expand all existing roads within the Hardwood Grove to 60 feet of right-of-way, connecting the north end of CR 88A and CR 88B to CR 88, protecting the alleyways south of CR 4, and providing another east-west access road for the area between County Roads 4 and 5.

County Road 99W

D-TR-5 Strict enforcement of keeping roads clear of parked vehicles and encroachment into the ROW.

D-TR-6 Development of the Town Center Specific Plan will include measures to improve safety at the intersection of CR 89, CR99W, and Main Street.

County Road 99W runs parallel to I-5 between the interstate and the California Northern railroad tracks. It is the only road that connects all three parts of Dunnigan and has been a safety concern for the community since it does not intersect community roads at a right angle.

Past concern about the intersection with CR 8 has been mitigated by improvements to the intersection including turning lanes and traffic lights. The intersection of CR 99W with CR 89 and Main Street is still considered a hazardous intersection. A crosswalk is painted across the intersection to provide a pedestrian access between Old Dunnigan east of CR 99W and the post

office and Dunnigan Market on the west side of the street (Figure 13). Although there are warning signs for pedestrians and the fire station on CR 99W, the speed limit is 45 miles per hour. Main Street and CR 89 have a stop sign, but there are no sidewalks or other improvements for pedestrian or bicycle safety.

Figure 14. Main Street, CR 99W, CR 89 Intersection



7. Environment and Public Services

Existing Environment and Public Services Conditions

Dunnigan's location, outside of the Sacramento River floodplain and well east of the higher fire severity areas of the Capay Hills and Blue Range, provides some security from the floods and wildfires that have afflicted California with increasing frequency in the twenty-first century. However, the community is rightly concerned about undeveloped lots that are overgrown with eucalyptus in the Hardwood Grove area and road flooding along Dunnigan Creek.

Dunnigan enjoys relatively clean air, but occasionally experiences high levels of ozone and other pollutants that are transported from the Sacramento area and smoke from wildfires. More localized sources of air pollution include dust and smoke from agricultural operations as well as vehicular emissions associated with Interstate 5.

Three channelized riparian corridors run from the Dunnigan Hills through the community: Dunnigan Creek, Azevedo Draw, and Bird Creek. All three are relatively absent of trees. Saturated soils or higher water tables limit the type of tree species found here. Periodic use of herbicides has also limited the natural progression of shrubs and grasses found along the creeks. The riparian corridor along Dunnigan Creek between County Road 88 and I-5 was altered from its natural state when material from this area was used for fill during construction of I-5.

Dunnigan lies within the North Yolo Groundwater Management Area, one of six within the Yolo Subbasin. This management area extends from the Yolo-Colusa County line on the north to Cache Creek on the south and between the eastern slopes of the Dunnigan Hills on the west to the Sacramento River on the east. In general, groundwater levels for the area have lowered during drought years but recover to a long-term average during wet periods.

The Dunnigan Water District (DWD) manages water delivery from the Tehama-Colusa Canal and provides agricultural water services and seasonal fire ponds outside the community. DWD also provides some water for landscaping and fire hydrants within the community. Fire hydrants are currently located at the motel on CR 6 and the truck stop and Country Fair Estates at CR 8. A private water company, California American Water, provides water and wastewater services to some of the southern part of Dunnigan around CR 8 including Country Fair Estates residents and Dunnigan Gateway development (Figure 14). Finally, Campers Inn provides services to approximately 120 people north of the Hardwood Grove.

All homes outside of southern Dunnigan have domestic wells and septic tank leach field systems for wastewater treatment. A few businesses have settling ponds rather than septic systems. Although there are a few small, shared water systems that serve several residences from common wells, there is no community water supply or sewer system. This has contributed to water quality concerns within the community.

Dunnigan has an existing Community Service Area though it is only for street lighting. County Service Area 11 (CSA 11) is a dependent special district that was formed under the auspices of the Yolo County Board of Supervisors in response to Dunnigan residents' desire for street lighting and more local control over public services. The primary goal of the lighting is to identify street

intersections that often become obscured by heavy fog. Thirty-five lights have been installed; there are no current plans to increase this number. The district encompasses about 605 acres. The boundary includes the Hardwood Grove and the Old Town area of Dunnigan.

Figure 15. California-American Water Service Area

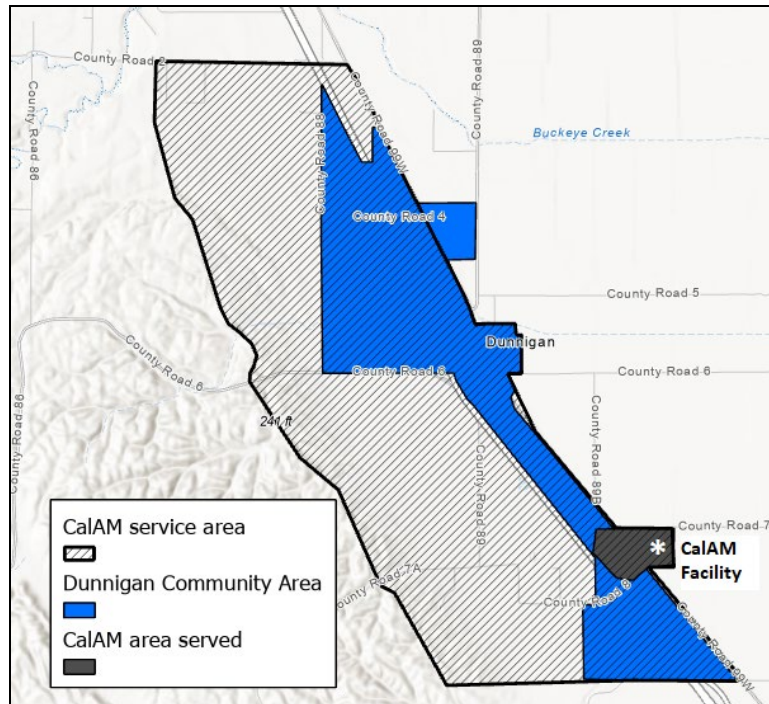

Yolo County provides many of the public services in Dunnigan including law enforcement, planning, building inspection, and road and street maintenance. Solid waste disposal is provided to the Dunnigan area by private waste disposal carrier franchise agreements with the County of Yolo. Fire Protection Services are provided by the Dunnigan Fire Protection District. The Dunnigan Fire Protection District was officially organized in the mid-1940s to provide fire protection service to the Dunnigan area. The district encompasses a large portion of northern Yolo County; an area of approximately 105 square miles.

The Dunnigan Fire Protection District is a volunteer-staffed district which provides fire protection and medical emergency services to an over 105 square mile area. It is the second largest service area within Yolo County. The district has 24 volunteers including a fire chief, assistant chief, captain, and two lieutenants. The station is located on Main Street in central Dunnigan. Firefighting equipment includes two pumper trucks, one tanker truck, and four smaller brush/grass units. Water is supplied within the district by the Dunnigan Water District conveyance system. The general condition of all the equipment is good, though some of the units are quite old. The fire district has a mutual aid agreement with other Yolo County fire districts to provide fire suppression services.

Children from the Dunnigan area are bused to public schools in Arbuckle, about ten miles north of Dunnigan in Colusa County. The Pierce Union School District operates four schools, three of which are in Arbuckle: an elementary school (grades K-6); a junior high school (grades 7-8); and a high school

(grades 9-12). The district also operates an elementary school in the community of Grimes. Facilities are near or over capacity. In particular, Arbuckle Elementary has been extremely impacted for the past six years and currently houses more than 550 students on a site that should only have 430 students.

The 2022-23 PJUSD Facilities Master Plan shows that 207 students originate from the Dunnigan area including 85 elementary school students. The district at one time operated a school in Dunnigan, but that facility was closed because it was considerably more expensive to operate than busing the students to Arbuckle. The district sold the old school site for use by the Dunnigan Water District and it is now owned by the Bureau of Reclamation. The Bureau is studying closing the site and would then offer it for sale to a public entity. The County or the School District acquiring the site could help meet the educational and recreational needs of the community.

There are no medical or other health care services offered in the Town of Dunnigan. Health services are generally sought in Woodland or Davis. Emergency medical transport (ambulance service) dispatched from Woodland usually require 45 minutes to deliver a Dunnigan area resident to a Woodland hospital.

Environmental Goals

Goal 4: Protect natural resources and community health and resiliency.

Air Quality

D-EPS 1. To mitigate noise and potential health hazards due to poor air quality along Interstate 5, the County shall require a minimum 300-foot setback from the right of way for I-5 for residential development and sensitive land uses. All development along Interstate 5 is encouraged to provide vegetative screening to provide a visual and noise buffer.

The California Air Resources Board (CARB) issued recommendations in the siting of new sensitive land uses in 2005. The recommendation advises avoiding concentrating sensitive land uses within 500 feet of rural roads with 50,000 vehicles per day. Additionally, noise levels for the stretch of I-5 between the I-505 interchange and the Colusa County Line can exceed the normally acceptable upper limit of 60 dBA for more than 250 feet from the interstate. Although I-5 has an annual average of 35,000 trips per day which is less than the threshold for the CARB recommendation, given the cumulative impacts of proximity to lower air quality and higher noise levels along the interstate, the Community Plan shall require a 300-foot setback from the interstate right-of-way for residential or sensitive land uses such as schools or hospitals.

Flooding

D-EPS 2. To protect riparian habitats and prevent risk to property, the County shall enforce a 100-foot development setback along Buckeye Creek, Bird Creek, Dunnigan Creek and Azevedo Draw.

During periods of heavy rains, saturated soils combined with high water levels in the Sacramento River and Colusa Basin Drainage Canal can slow drainage from the planning area, resulting in backup and overflow of Dunnigan and Buckeye Creek's banks near their confluence with the canal.

Other drainage problems include ponding in the Hardwood Grove west of I-5 and a smaller area of ponding east of and adjacent to the Southern Pacific Railroad tracks at County Road 4. Bridge locations crossing creeks subject to 100-year storms are also subject to potential flooding where their design prohibits 100-year storm flows causing access problems during periods of heavy rain. There are several such locations along Dunnigan and Buckeye Creeks.

Groundwater

In 2014, the California adopted three bills that are collectively known as the Sustainable Groundwater Management Act (SGMA). The Act requires the formation of local groundwater sustainability agencies in priority groundwater basins and subbasins. Yolo County is designated a high-priority area and the Yolo Subbasin Groundwater Agency was formed in 2017 to develop a Groundwater Sustainability Plan, which was adopted in 2022.

Dunnigan lies within the North Yolo Groundwater Management Area, one of six within the Yolo Subbasin. This management area extends from the Yolo-Colusa County line on the north to Cache Creek on the south and between the eastern slopes of the Dunnigan Hills on the west to the Sacramento River on the east.

Water table measurements regularly taken from three wells located between County Road 99W and I-5 provide a reasonable assessment of general ground water conditions throughout the planning area. Measurements have been taken since 1926 during the wet winter and late dry summer conditions. All wells exhibit declining ground water levels over time with greater fluctuations during the summer months, when ground water pumping for agricultural lands in the area are at their highest level.

Since the Dunnigan Water District began delivery of surface water to agricultural uses from the Tehama-Colusa Canal, fluctuating ground water levels in the Dunnigan area have stabilized and in some cases ground water levels have risen. Dunnigan Water District has begun a groundwater recharge project using the Tehama-Colusa Canal and Buckeye Creek to convey a planned 5,000 acre feet of water onto fallow agricultural land and eventually back into the aquifers.

As noted earlier, the County's Environmental Health Services has surveyed a number of small public water systems in the Dunnigan area and found nitrate levels that exceed State and Federal standards.

Fire Hazards

D-EPS 3. Landowners within the Hardwood Grove should maintain a 100-foot defensible space around their home clear of dense eucalyptus groves and thin eucalyptus on undeveloped lots. Where appropriate, removed eucalyptus shall be replaced with oaks and other native tree species.

The Dunnigan region was originally covered with oak woodland-grassland plant communities and riparian corridors. With nineteenth century settlement, much of this area was converted to farming and livestock raising though some oak woodlands-grasslands landcover remains to the west of the community. In the early twentieth century the northern part of the community was planted in red gum eucalyptus (*Eucalyptus camaldulensis*) in the hopes of producing lumber for railroad ties. Though red gum wood is hard, it grows in an irregular, crooked shape and the wood does not season well as it warps and splits during the process. Eventually, the eucalyptus operation closed, and the lots were sold off and used for homesites.

Thick groves of red gum remain mainly on undeveloped parcels and are an identifying feature of the community, but the fire-adapted trees are also a hazard. Eucalyptus trees shed bark and branches and emit volatile oils that contribute to the fire regime of their native habitats in Australia and regrow from branches allowing them to recover more quickly than competing species. Cal Fire designates the community as a Local Responsibility Area, so it does not define the Fire Hazard Severity of the area. The similarly developed area of the Hardwood Grove currently outside the Community Boundary and east of CR 99W is designated as a Moderate Fire Hazard Severity Area.

2024 Dunnigan Community Plan

California Public Resources Code Section 4291 requires property owners in forest-covered lands to maintain a defensible space of 100 feet around structures. Most developed residential parcels in the Hardwood Grove appear to have a defensible space, but there are several larger parcels that do not appear maintained. Although PRC 4291 doesn't apply to owners of undeveloped parcels, given the density of homes within the area, efforts ought to be made to have all property owners reduce the density of red gum eucalyptus and clear fallen bark and limbs.

Public Services Goals

Goal 5: Provide the level of public services desired by the residents at an equitable cost.

Dunnigan has historically not received much investment in safety or services and is considered a disadvantaged community by the State. Continuing concerns within the community include water quality, the condition of the roads, emergency services including fire, sheriff, and ambulance availability, and schools.

Water and Wastewater

D-EPS-4 The County shall explore private and public funding sources for providing community water and wastewater service.

Dunnigan has a history of high levels of nitrates in the drinking water. Elevated nitrate levels were detected in 1982 in a study conducted by Yolo County Environmental Health Services and in 1993 by Wallace, Kuhl & Associates in their Groundwater Pollution Study for the Dunnigan area. Both studies indicated that onsite septic systems, especially those that are old and close to old water wells could be a major cause for the nitrate problem. Both studies did not preclude other factors such as domestic or commercial agricultural practices and other old and improperly constructed sewage systems in the area. High levels of nitrates in drinking water may cause health problems, particularly in infants.

Despite the history of a nitrate problem in the drinking water and more recent concerns regarding wells going dry from drought, northern and central Dunnigan have not had a plan to provide safe water to the residents. In 1993, the County hired Psomas & Associates of Sacramento to write a preliminary facilities plan to address water, wastewater, and drainage needs for the community. The *Dunnigan Facilities Plan* was left incomplete however, when the developers attached to the project withdrew financial support in 1995.

For the current community plan, the *Dunnigan Infrastructure Feasibility Study* was conducted to look at the needs and costs of providing water and wastewater service to the existing development in central and northern Dunnigan including the Old Town and Hardwood Grove area (Attachment A). It proposes that two new wells, a primary well and a backup well located near Dunnigan Creek to provide water to the central and northern part of the community.

Alternative sources of water were investigated including the Dunnigan Water District or the existing California American Water facilities which serve parts of the community. Due to the ongoing drought, Dunnigan Water District does not have the capacity to serve the non-agricultural needs of the community with water from the Tehama-Colusa Canal. California American Water owns water and wastewater treatment facilities at County Road 8 which serve the adjacent Country Fair Estates Mobile Home Park and Dunnigan Gateway commercial center. The company's business model however is to acquire existing facilities rather than construct new infrastructure.

The probable construction costs of these facilities are included in the study. The sewer collection system is estimated at \$8.4 million with a package wastewater treatment plant of \$12 million. The water distribution system is expected to cost \$12.7 million and the wells, tanks, water treatment and pumps are likely to cost an estimated \$11.3 million. The total cost for a community water and wastewater system including contingencies would likely be an estimated \$60 million.

The economic feasibility part of the study looks at how much the cost of infrastructure would add to the cost of infill housing allowed by current zoning. The study found that this approach would not be feasible

since it would add well over \$100,000 to each new single-family home. Expanding the amount of area available for residential development would reduce this amount in relation to the amount of housing added. For example, the 153 acres of new residential land uses to be included in the Specific Plan areas, if developed at a typical density of six to seven dwelling units per acre, could reduce the additional infrastructure costs to closer to \$100 per home.

At the development densities proposed for the Specific Plan areas, individual wells and septic systems are inadequate. A public water and/or sewer system is also necessary to solve the nitrate problem in the existing town as described above. In developing the Specific Plan areas, the capacity of the major water and sewer lines and of the sewer plant should be sufficient to accommodate the demand from existing developed areas. Developers should be reimbursed for providing this additional capacity to solve existing problems.

Excess water and sewer capacity should be considered in the future to allow existing development in Dunnigan to eventually use the collection and treatment facilities. The County can adopt an ordinance that includes the requirement that "improvements installed by the subdivider shall contain supplemental size, capacity, number, or length for the benefit of property not within the subdivision, and that those improvements be dedicated to the public (Govt. Code 66485)." The County would be required to enter into an agreement with the subdivider for reimbursement for costs in excess of the construction required for the subdivision.

Another option is to coordinate development of infrastructure with California American Water, a private water company that includes the entire community of Dunnigan in its service area though it only currently serves a portion of the part of the community. Although the company has expressed interest in managing future facilities in the community, they have not proposed funding the construction of the facilities proposed in the *Dunnigan Infrastructure Feasibility Study*. To this end, the County should pursue public funding either to implement the needed infrastructure in conjunction with a developer or independently.

The County of Yolo has established a number of County Service Areas and Community Service Districts throughout the unincorporated County that provide public services, such as water, sewer, storm drainage, and road maintenance; the governing body for a County Service Area is the Yolo County Board of Supervisors. County Service Area No. 11 or formation of a Community Service District would likely be the water and/or sewer purveyor. County Service Area No 11 (CSA-11) was formed to provide street lighting for the Dunnigan area. The petition adopted by the Local Agency Formation Commission when the service area was formed allows CSA-11 to provide other urban services that may include water and/or sewer service. However, either the formation of a Community Service District or management by California American Water would be preferable to a CSA for the expanded services.

Law Enforcement, Fire, and Medical Services

D-EPS-5. The County shall work with the Dunnigan Fire Protection District to improve emergency access and fire prevention through road additions and improvements, water storage and distribution, eucalyptus thinning, and trash abatement.

D-EPS-6. Establish a sheriff's substation and ambulance service in the community to shorten response times.

D-EPS-7. Health care and emergency services should be planned to precede or coincide with the increase in the demand beyond current capacities as a result of development.

2024 Dunnigan Community Plan

Law enforcement in Dunnigan is provided primarily through the Yolo County Sheriff's Department. Telephone calls for services are routed to the dispatch at the Yolo County Communications Emergency Services Agency in Woodland. From this point, deputies are assigned to respond. The Sheriff's Department covers all of the unincorporated areas of Yolo County. The time it takes an officer to arrive to an emergency call can vary greatly, depending on proximity of a patrol vehicle. The County should evaluate if a Sheriff's substation is warranted in Dunnigan to serve new development envisioned by this plan.

The California Highway Patrol provides limited services to the Dunnigan area. Wireless phone calls for service involving the use of 911 are sent to the California Highway Patrol's communications dispatch in Sacramento.

The Dunnigan Fire Protection District is responsible for providing fire protection and medical emergency services to approximately 105 square miles of the northern County including the community of Dunnigan. Fire district staffing consists of 24 firefighters. Several of the volunteers have emergency medical technician training. The fire district has a mutual aid agreement with other Yolo County fire districts to provide fire suppression services. As with many rural fire districts, the fire district is struggling to maintain an adequate level of service due to lack of funding. Staff has assisted in out-of-state firefighting to help raise revenue, which leaves less staff available for local emergency needs.

Dunnigan FPD's call volume in FY 20/21 was the 3rd highest in Yolo County at 551 dispatches (including mutual aid calls). The difference is the FPDs with comparable/higher call volume have 2.5 – 4 FTE paid staff each. It appears the Dunnigan FPD is receiving a lower level of service as compared to other FPDs which is likely due in part to its disadvantaged status and corresponding lack of funding. Support of a Proposition 218 is likely affected by the disadvantaged income status of roughly half of its territory. Incident response data indicates Dunnigan FPD is struggling to respond to calls with sufficient personnel. Call volume has increased significantly at 42% over the last three years. More personnel, likely paid staff, is needed to serve the Dunnigan FPD high demands for service. But Dunnigan FPD's core revenues are relatively low, even though in FY 20/21 it had the highest number of dispatches of all the FPDs inside its jurisdiction (i.e., not including mutual aid calls). Dunnigan FPD needs increased personnel, which will likely require increased revenue.

There is no medical care in Dunnigan; the nearest hospital is in Woodland. The nearest ambulance service is also in Woodland. Non-life threatening calls can take as long as one hour from the initial call to delivering a person via ambulance to the hospital in Woodland. For life threatening emergencies, the fire department or the California Highway Patrol will call Life Flight, a medical-helicopter service based in Sacramento.

The Town of Dunnigan has no medical and other health care services. Health services are generally sought in Woodland or Davis for any complicated or extensive medical treatment. Ambulances dispatched from Woodland can take up to an hour to deliver a Dunnigan area resident to a Woodland hospital. As a result of the time lag, many people choose to drive the injured or ill into Woodland rather than rely on an ambulance. For these reasons, emergency medical technicians (EMTs) are needed to serve the Dunnigan area.

The increase of commercial, industrial, and residential development will require a commensurate increase in fire-fighting capabilities. The Dunnigan Fire Protection District should conduct a study of the equipment, staffing, and facility needs of the fire protection district at full build-out of this plan. As a condition of approval, developers should pay for their fair share amount of the fire protection equipment and facilities to service their development.

If a large amount of commercial and retail businesses locates in Dunnigan, there may also be an increase in law enforcement problems associated with this development. Prior to approving such projects, the County shall review law enforcement service needs generated by the new development. If the study concludes that cumulative impacts require a new substation in Dunnigan, developers should pay their fair share amount towards building such a facility to service their development.

New development is expected to pay its fair share for the cost of providing additional services. However, the cost of upgrading and expanding public services that serve the existing residents cannot be shifted to developers. At the same time, the costs of new facilities to existing residents cannot be so onerous that low-income families are forced to move.

Schools

D-EPS-8. The County shall ensure that new residential subdivisions within the Pierce Unified School District provide for additional student population with a focus on establishing a local school in Dunnigan to serve the community and neighboring region.

Since there is no school site in Dunnigan, children are bused 10 miles north to schools in Arbuckle which were not designed for the additional students. The elementary school facilities in particular have been severely impacted by high number of students attending. Pierce Unified School District has provided comments that its preference is to establish a small transitional kindergarten to eighth grade school in Dunnigan. There would not necessarily need to be sufficient population to have full classes (30 students per class) for each grade level before a new elementary school in Dunnigan could be considered. PJUSD's Grand Island Elementary School in Grimes, California functions well with combination grades which is often more desirable for small group instruction. State law allows school districts to collect fees from new commercial and residential development to construct new facilities. School siting requirements are found in Title 5, Division 1, Chapter 13 of the California Code of Regulations.

Exhibit A. Parcels with Land Use Designation or Zoning Changes

APN	Acreage	Current Designation	Proposed Designation	Current Zoning	Proposed Zoning
Residential east of 99W (24 land use designation changes)					
051090010	2.39	AG	RR	A-N	RR-5
051090011	6.42	AG	RR	A-N	RR-5
051090027	3.06	AG	RR	A-N	RR-5
051090028	2.22	AG	RR	A-N	RR-5
051090029	2.22	AG	RR	A-N	RR-5
051090030	2.31	AG	RR	A-N	RR-5
051190019	5.37	AG	RR	A-N	RR-5
051190020	3.73	AG	RR	A-N	RR-5
051190021	2.07	AG	RR	A-N	RR-5
051190022	5.66	AG	RR	A-N	RR-5
051190024	4.73	AG	RR	A-N	RR-5
051190025	4.68	AG	RR	A-N	RR-5
051190029	0.97	AG	RR	A-N	RR-5
051190030	0.97	AG	RR	A-N	RR-5
051190031	0.97	AG	RR	A-N	RR-5
051190032	0.98	AG	RR	A-N	RR-5
051190033	0.98	AG	RR	A-N	RR-5
051190034	0.98	AG	RR	A-N	RR-5
051190035	0.95	AG	RR	A-N	RR-5
051190036	0.95	AG	RR	A-N	RR-5
051190037	0.95	AG	RR	A-N	RR-5
051190038	0.95	AG	RR	A-N	RR-5
051190039	0.95	AG	RR	A-N	RR-5
051190040	0.95	AG	RR	A-N	RR-5
Specific Plan areas (7 Land use designation changes)					
051160007	0.25	CL	SP	C-L	S-P
051160008	0.21	CG	SP	C-H	S-P
051160013	53.55	CG, CL	SP	C-H, C-L	S-P
051160020	167.1	AG	SP	A-N	S-P
051160023	13.63	AG	SP	A-N	S-P
051160024	30.81	AG	SP	A-N	S-P
051160098	0.24	CL	PQ	C-L	PQP
CR 6 to CR 7 (4 land use designation changes)					
052030004	17.73	AG	CG	A-N	C-G
052030007	76.41	AG	IN	A-N	I-L
052030022	42.22	AG	CG, RL, CL	A-N	C-G, R-L, C-L
052130001	8.2	AG	PQ	A-N	PQP
Hardwood Grove (5 land use designation changes)					
051110007	2.0	RM	RR	R-M	RR-2
051110008	5.0	RM	RR	R-M	RR-2
051110011	6.0	RM	PQ	R-M	PQP
051120001	12.99	CL	RR, CL	C-L	RR-5, C-L

2024 Dunnigan Community Plan

APN	Acreage	Current Designation	Proposed Designation	Current Zoning	Proposed Zoning
051202002	6.04	IN	RR	I-H	RR-2
Central Dunnigan (7 land use designation changes)					
051160004	2.4	CG	CG	C-H	C-G
051160005	16.08	CG	CG	C-H	C-G
051160010	0.55	CG	CG	C-H	C-G
051221001	0.36	PQ	PR	PQP	P-R
051224001	0.29	PQ	PR	PQP	P-R
051231001	0.55	IN	PQ	I-H	PQP
051242001	1.36	PQ	PR	PQP	P-R
051242002	0.33	PQ	PR	PQP	P-R
051244004	3.15	IN	CL	I-L	C-L
052020003	5.07	CG	CG	C-H	C-G
052020004	1.0	CG	CG	C-H	C-G
052030020	2.12	AG	IN	A-N	I-L
052030023	4.23	CG	CG	C-H	C-G
Existing Wastewater Facility (4 land use designation changes)					
052130009	39.3	AG	PQ	A-N	PQP
052030017	8.2	AG	PQ	A-N	PQP
052020005	5.25	AG	PQ	A-N	PQP
051160012	2.0	CG	PQ	C-H	PQP
County Road 8 (1 land use designation changes)					
052060011	100.00	CG	CG	C-H/ PD-65	C-H
052060018	140.89	AG	AG	A-N	A-I
052130007	90.39	CG	IN	C-H	I-H

Land Use Designations

- AG Agriculture
- CG Commercial General
- CL Commercial Local
- IN Industrial
- PQP Public/Quasi-Public
- PR Parks and Recreation
- RM Residential Medium
- RR Residential Rural
- SP Specific Plan

Zoning

- A-I Agricultural Industrial
- A-N Agricultural Intensive
- C-H Highway Service Commercial
- C-G General Commercial
- C-L Local Commercial
- I-H Heavy Industrial
- I-L Light Industrial
- PD Planned Development Overlay
- P-R Parks and Recreation
- PQP Public/Quasi-Public
- R-M Residential Medium
- RR-2 Residential Rural (2-acre minimum)
- RR-5 Residential Rural (5-acre minimum)
- S-P Specific Plan

Attachment 1. Dunnigan Infrastructure Feasibility Study



MEMORANDUM

To: Jamie Gomes, Economic & Planning Systems

CC: JD Trebec, Yolo County

From: Steve Greenfield, PE, ^{SGG}Cunningham Engineering Corporation (CEC)
Shekhar Raj Mote, CEC

Date: 14 December 2022

Subject: Dunnigan Sewer and Water Feasibility Study

This memo provides a summary of the feasibility study conducted for providing public sewer services and water mains in the Old Town and Hardwoods/Grove area of Dunnigan (Study Area). Currently, the residents use either septic tanks or sewer percolation ponds to discharge sanitary sewage. Having developed prior to current County standards which require a 2-acre lot minimum for septic systems, nearly all the existing residential lots, approximately 250 lots, in the study area are an acre or less. This has contributed to nitrogen contamination in the ground water. In addition, residents use private wells as their source of drinking water, with evidence of recent well failures. Providing public water and sewer services would not only improve the water quality of current residents, but also allow for increased housing density and local business growth.

CEC has prepared this analysis for providing public sewer and water infrastructure based on proposed land use/density assumptions provided by Yolo County Planning as presented in Exhibit A.

Demands

Acreage and existing zoning information for each parcel within the study area were obtained from Yolo County GIS. Considering the County recommended freeway setbacks and estimated net developable acreage, EPS provided the density (developable units/acre) for each parcel that they categorized as either underutilized parcel or parcels for development or vacant parcels. Based on these proposed building densities, the land use for these parcels were determined using Table 1 below. For the remaining existing parcels and the corresponding existing land use, number of developed units were estimated using average density number in Table 1 below. Then, based on the developable units for the residential land uses and acreage for the other land uses, the sanitary sewer design flow and water demands were obtained as per Yolo County improvement standards as shown on Table 1 below, modified as described below the table based on water conservation practices.

Land Use	Unit	Density	Sewer Demand (gal/unit/day)	Water Demand (gal/unit/day)
Rural Residential (RR)	Dwelling Unit	1-2 units/acre (Average 1)	350	728
Low Density Residential (RL)	Dwelling Unit	3-10 units/acre (Average 5)	350	728
Medium Density Residential (RM)	Dwelling Unit	11-20 units/acre (Average 14.2)	300	521
Public and Quasi Public (PQP)	Acreage		2500	1780
Commercial Local (CL)	Acreage		2500	2598
Commercial Highway (CH)	Acreage		3500	2598
Industrial (IL)	Acreage		3500	2598

Table 1: Yolo County Standard Land Use-Density-Demand for sewer and water

The water demand and sewer generation rates shown above do not reflect current water conservation practices throughout the State. Based on analysis prepared in 2012 during preparation of the draft Dunnigan Specific Plan, a 20% reduction in demand/generation was applied for this analysis.

For the sewer demand, flows from the Dunnigan safety roadside rest area was assumed to be connected to the proposed sewer collection system. The demands were estimated based on the monthly water usage data of the Dunnigan rest area provided by the client as shown on Exhibit B.

Analysis and Recommendations

Sanitary Sewer

Cumulative peak flow of 1.6 million gallons (MG) per day and average dry weather flow of 0.4 MG per day was estimated as shown on Exhibit C. For the community of this size with potential growth in future, CEC recommends a package sewage treatment plant because of the following factors:

- i) Fully portable when completely assembled and can be moved if required.
- ii) Can be placed above/below/partially below ground without a concrete surround.
- iii) Requires minimal maintenance, power and spare parts.

Furthermore, although the typical capital cost is higher, a membrane bioreactor (MBR) treatment plant is recommended over conventional activated sludge process (ASP) system because of the following advantages as mentioned on EPA Wastewater Management Fact Sheet attached as Exhibit D in this report:

- i) The effluent from MBRs contain low concentrations of bacteria, total suspended solids (TSS), biochemical oxygen demand (BOD), and phosphorus, which facilitates high-level disinfection and thus the effluents can be readily discharged to surface streams or

can be sold for reuse, such as irrigation. This will be critical to achieve permit approval to discharge treated effluent to Dunnigan Creek.

- ii) The low retention times mean that less space is required compared to a conventional system, which will reduce land acquisition costs.

The effluent discharge from the treatment plant is proposed to be discharged into Dunnigan Creek. Hence, as a preliminary placeholder, the treatment plant is proposed to be located just north of Dunnigan Creek as shown on Exhibit E; on a vacant parcel (051-160-013) east of Interstate 5 and south of Country Road 5. This location was selected based on the following factors:

- i) Proximity to Dunnigan Creek for effluent discharge.
- ii) Freeway buffer land area can be used for non-residential uses.

The plant size is estimated to be 170' x 65', which includes a 500,000-gallon equalization tank, a 200,000-gallon aeration tank, MBR basin, and 160,000-gallon sludge holding tank

The sewer collection system network was laid out as shown on Exhibit E. The sizes of conveyance pipes were determined using Manning's formula and in accordance with "Section 7 Sanitary Sewers" of Yolo County Improvement Standards. Sizing calculations are shown on Exhibit C. The design factors used for determining pipe sizes include:

- i) Mannings "n" = 0.013
- ii) Slope = Minimum provided such that the velocity of flow in the pipe when full is not less than two feet per second.
- iii) Flow Depth (d/D) = Maximum 0.7 of the pipe diameter
- iv) Infiltration Rate = 600 gal/acre/day
- v) Peak Factor = 3

Most of the sewer pipes are proposed to be within the public Right of Way (ROW). However, the following issues were considered for routing and estimating the cost of the conveyance network. Jack and bore would be required for following conditions:

- a) Under Interstate 5 along Country Road 5 to connect the sewer flow from the Hardwoods area to the proposed wastewater treatment plant location.
- b) Under Southern Pacific Railroad and Country Road 99W along Main St to connect the sewer from the Old Town area to the proposed sewer main along County Road 99W.
- c) Under Dunnigan Creek to connect the sewer main from Old Town area to the proposed wastewater treatment plant location.

In addition, a lift station is proposed near the intersection of Main St and 99W to avoid deep pipe covers.

Water

1.7 MG of maximum day and 0.8 MG of average day water demands were estimated for the project area for proposed land use condition. Considering just the existing land use for current residents, 0.9 MG of maximum day and 0.5 MG of average day water demands were estimated. The demand calculations are shown on Exhibit F.

For determining potential municipal water source options, CEC reached out to The Dunnigan Water District and to California American Water. CEC met with Mr. William Vanderwaal, Deputy Manager of Dunnigan Water District (DWD) on Oct 7th, 2022. Mr. Vanderwaal indicated the district has a contract with the Bureau of Reclamation (Tehama Colusa Canal) for 19,000 acre-feet (AF) water per year until 2025. However, the majority of this surface water is committed for agricultural land uses and is not readily available for residential needs. Hence, CEC met with Mr. Evan Jacobs, External Affairs of California American Water company on Oct 19th, 2022, to explore groundwater options as a source. He indicated that the study area has already been annexed into California American Water district through Public Utilities Commission (PUC). Also, according to the Technical Appendix D – Water Supply prepared by PACE Advanced Water Engineering dated January 2013, Dunnigan Water District undertook an evaluation of its existing and projected land uses in its Groundwater Management Investigation completed in 2005, which summarized that the recharge exceeds extraction by approximately 1,000-to-5,000-acre feet per year on average. Since the residents are also already using the private wells to meet their current demand, groundwater extraction is considered a viable option for this study area.

California American representatives indicated that two wells, one for redundancy, would be required. In addition, a 1.7 MG storage tank would be required to provide operational storage, fire water demand and emergency storage for proposed land use condition. Considering just the existing land use for current residents, a 1.1 MG storage tank would be required. The storage volume calculation is shown in Exhibit F. One groundwater well with adequate capacity to pump the maximum daily demand (MDD) water supply is assumed, with one more as redundant well to supply MDD when the primary well is out of service. Depending upon the location of the groundwater well and the corresponding ground elevation, booster pumps will be required to provide adequate pressure in the distribution system. The schematic location of groundwater wells, a treatment plant, storage tank, booster pump station and the water main distribution network layout is shown in Exhibit G.

Most of the water lines are within the public Right of Way, however, the following issues were considered for routing and estimating the cost of the distribution network. Jack and bore would be required for following conditions:

- a. Under Interstate 5 along Country Road 4 and Country Road 5 to connect the east and west areas in Hardwoods area.
- b. Under Interstate 5, Southern Pacific Railroad and Country Road 99W along Country Road 6 to connection the Old Town area with the main grid.
- c. Under Southern Pacific Railroad along Main Street to connect Old Town area with main grid.

Engineer's Opinion of Probable Cost

CEC estimated the construction cost to be \$28 million for water treatment and distribution system and \$32 million for sewer collection and treatment system, with the total construction cost of \$60 million. This planning level estimate includes a 25% design contingency and a 10% construction contingency. This estimate does not include costs for land acquisition. The itemized cost estimate is shown in Exhibit H.

Regulatory Permits and Actions

Construction of this project would require the following regulatory permits and actions:

- i) Land acquisition for improvements i.e., WWTP/Wells
- ii) Biological assessments/Special status species surveys: Environmental Site Assessments
- iii) National Historic Preservation Act (NHPA) (Section 106) Review: This is required if applying for Federal Grants and allowing the Advisory Council on Historic Preservation (ACHP) to comment on proposed plans – identify affects and evaluate avoidance measures and mitigation measures.
- iv) CEQA and NEPA Review: This is required if applying for Federal Grants.
- v) Yolo County Habitat Conservation Plan (HCP) approval – Yolo County Conservancy: Application for approval through the conservancy.
- vi) Groundwater Reporting managed by Groundwater Sustainability Agencies (GSAs): As per Sustainable Groundwater Management Act (SGMA).
- vii) Waste Discharge Permit – California State Water Resources Control Board: This is required for discharging the WWTP effluent into Dunnigan Creek.
- viii) 1602 Streambed Alteration Permit – CA Dept of Fish and Wildlife: This is required when depositing or disposing of material into any river, stream or lake.
- ix) 401 and 404 Permit – Clean Water Act – US Army Corps of Engineers: This is required when discharging material into the waters of the US.
- x) Water Well Permits – Yolo County Environmental Health Approval
- xi) Construction General Permit Coverage / WDID Number – State Water Resources Control Board: Stormwater Pollution Prevention Plan (SWPPP) will be required to be prepared and implemented
- xii) Infrastructure Improvement Plans: Civil engineering improvements plans for the proposed infrastructure will be processed through County, California American Water and Caltrans for approval.
- xiii) Encroachment Permit – Yolo County
- xiv) Encroachment Permit – Caltrans
- xv) Encroachment Permit – Union Pacific Railroad: Encroachment permit required for crossing the railroad right-of-way located on the east side of County Road 99W to construct improvements.
- xvi) Community Services District formation

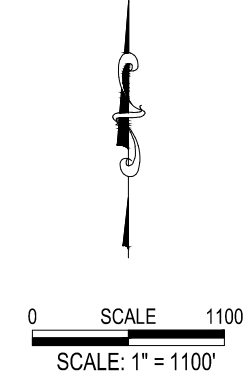
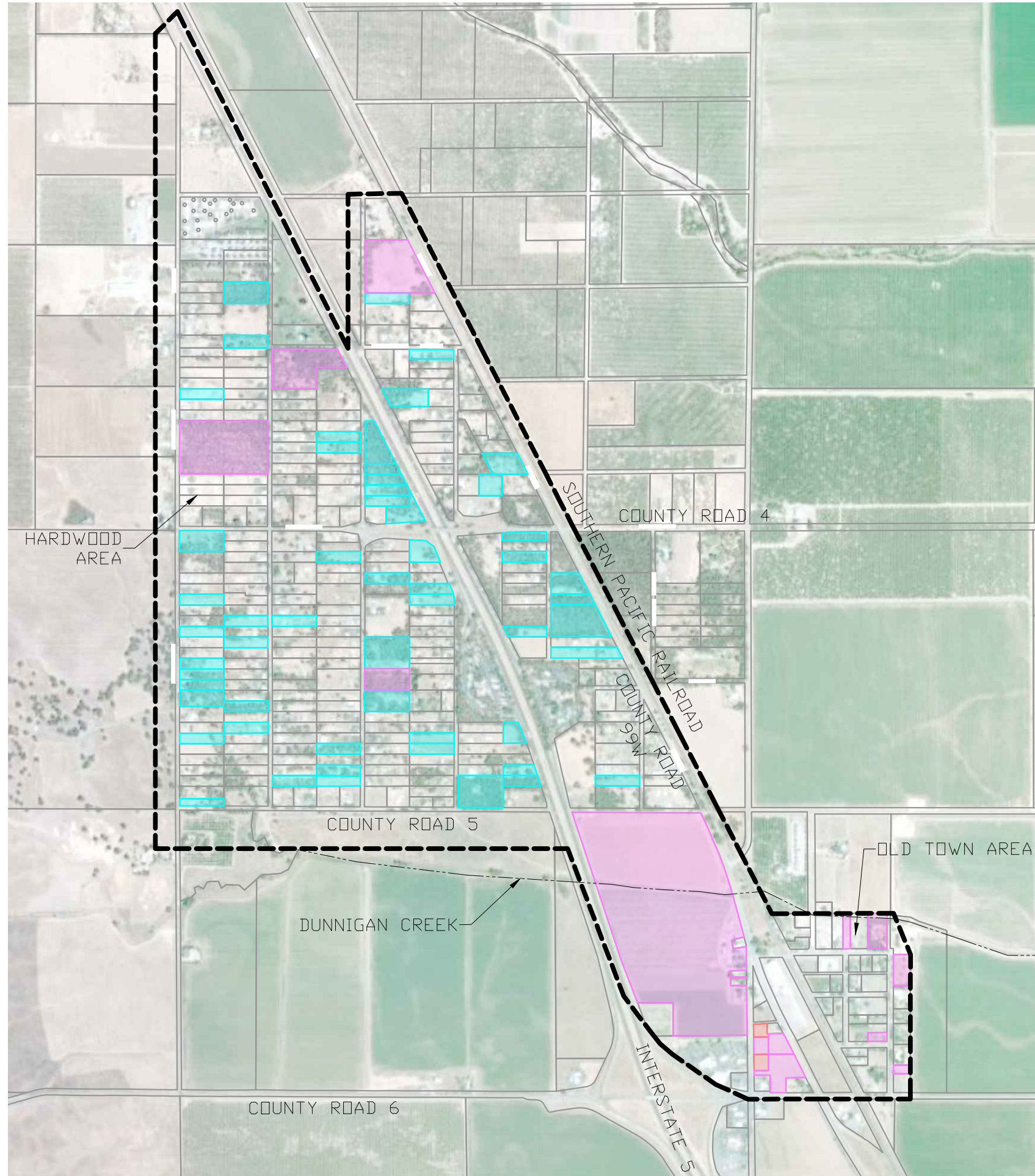

- LEGEND**
- EXISTING PARCELS (EXISTING ZONING REMAINS)
 - PROPOSED RURAL RESIDENTIAL (RR)
 - PROPOSED LOW DENSITY RESIDENTIAL (RL)
 - PROPOSED COMMERCIAL LOCAL (CL)
 - STUDY AREA
 - DUNNIGAN CREEK

PROPOSED RESIDENTIAL LAND USE DENSITY

RR 1-2 Building Units per Acre
 RL 6 Building Units per Acre

DUNNIGAN SEWER AND WATER FEASIBILITY STUDY
EXHIBIT A: PROPOSED LAND USE
 FOR VACANT, UNDERUTILIZED AND PARCELS FOR DEVELOPMENT
 YOLO CALIFORNIA

DESIGNED	SG
DRAWN	SM
CHECKED	SG
SCALE	
1" = 1100'	
SHEET	
1	
OF	
1	
DATE:	11/02/22
JOB No:	1940.01

CECWEST.COM

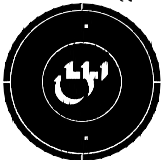

Project Planning ■ Civil Engineering ■ Landscape Architecture
 Sacramento Office ■ Davis Office
 2120 20th Street, Suite Three 2940 Spafford Street, Suite 200
 Sacramento, CA 95818 Davis, CA 95618
 (916) 455-2026 (530) 758-2026

TABLE SS-1



Cunningham Engineering Corp.
2940 Spafford Street, Suite 200
Davis, CA 95618

Design Criteria:
Infiltration Rate (all sizes) = 600
Mannings "n" = 0.013
Peaking factor = see table

gal/acre/day
Manning's formula $q=A(1.49/n)R^{2/3}S^{1/2}$

Project: Dunnigan SACOG REAP Date: 2-Nov-22
Project No.: 1940.00 Calc By: SM
Location: Dunnigan, CA Checked By: SG

* Incorporates 20% flow rate reduction based on water conservation requirements.

Land Use Area and Flow Rate Table

Inlet			Land Use Unit														Land Use Flow Rate															
Area	From	To	RR (BU)	RE (BU)	RL (BU)	RM (BU)	RH (BU)	MU (AC)	CL (AC)	CG (AC)	HC (AC)	OFF/RD (AC)	LI (AC)	PQ (AC)	PS (Std)	CP (AC)	NP (Unit)	Area (ac)	RR (gal/u/d)	RE (gal/u/d)	RL (gal/u/d)	RM (gal/u/d)	RH (gal/u/d)	MU (gal/u/d)	CL (gal/u/d)	HC (gal/u/d)	OFF/RD (gal/u/d)	LI (gal/u/d)	PQ (gal/u/d)	PS (gal/u/d)	CP (gal/u/d)	NP (gal/u/d)
1	0	1							12.0									11.7	280	280	280	240	240	2000	2000	2800	2000	2800	2000	40	160	160
2	1	2	17.0		57.0	172.0												36.7	280	280	280	240	240	2000	2000	2800	2000	2800	2000	40	160	160
3	2	3	36.0															24.9	280	280	280	240	240	2000	2000	2800	2000	2800	2000	40	160	160
4	3	4	1.0															0.7	280	280	280	240	240	2000	2000	2800	2000	2800	2000	40	160	160
5	28	24	28.0		25.0	218.0												44.1	280	280	280	240	240	2000	2000	2800	2000	2800	2000	40	160	160
6	24	4	57.0															49.8	280	280	280	240	240	2000	2000	2800	2000	2800	2000	40	160	160
7	4	5	2.0															1.9	280	280	280	240	240	2000	2000	2800	2000	2800	2000	40	160	160
8	25	5	79.0		12.0													67.5	280	280	280	240	240	2000	2000	2800	2000	2800	2000	40	160	160
9	5	6	1.0															1.4	280	280	280	240	240	2000	2000	2800	2000	2800	2000	40	160	160
10	29	26	5.0															4.5	280	280	280	240	240	2000	2000	2800	2000	2800	2000	40	160	160
11	26	6	37.0															40.3	280	280	280	240	240	2000	2000	2800	2000	2800	2000	40	160	160
12	6	7																0.0	280	280	280	240	240	2000	2000	2800	2000	2800	2000	40	160	160
13	7	8																0.0	280	280	280	240	240	2000	2000	2800	2000	2800	2000	40	160	160
14	37	36	6.0															4.7	280	280	280	240	240	2000	2000	2800	2000	2800	2000	40	160	160
15	36	34	9.0															8.2	280	280	280	240	240	2000	2000	2800	2000	2800	2000	40	160	160
16	35	34	21.0															18.2	280	280	280	240	240	2000	2000	2800	2000	2800	2000	40	160	160
17	34	33	4.0															4.2	280	280	280	240	240	2000	2000	2800	2000	2800	2000	40	160	160
18	33	31																0.0	280	280	280	240	240	2000	2000	2800	2000	2800	2000	40	160	160
19	32	31	30.0															20.7	280	280	280	240	240	2000	2000	2800	2000	2800	2000	40	160	160
20	31	30	2.0															11.0	280	280	280	240	240	2000	2000	2800	2000	2800	2000	40	160	160
21	30	8											6.0					5.6	280	280	280	240	240	2000	2000	2800	2000	2800	2000	40	160	160
22	89	90	18.0		36.0													22.5	280	280	280	240	240	2000	2000	2800	2000	2800	2000	40	160	160
23	90	91																0.0	280	280	280	240	240	2000	2000	2800	2000	2800	2000	40	160	160
24	91	38																0.0	280	280	280	240	240	2000	2000	2800	2000	2800	2000	40	160	160
25	38	88	5.0										10.0					15.9	280	280	280	240	240	2000	2000	2800	2000	2800	2000	40	160	160
26	88	8																0.0	280	280	280	240	240	2000	2000	2800	2000	2800	2000	40	160	160
27	8	WWTP																0.0	280	280	280	240	240	2000	2000	2800	2000	2800	2000	40	160	160
28	83	82			52.0									1.0				9.2	280	280	280	240	240	2000	2000	2800	2000	2800	2000	40	160	160
29	82	80			24.0													3.4	280	280	280	240	240	2000	2000	2800	2000	2800	2000	40	160	160
30	81	80			24.0									1.0				6.7	280	280	280	240	240	2000	2000	2800	2000	2800	2000	40	160	160
31	80	78			23.0								1.0	1.0				6.5	280	280	280	240	240	2000	2000	2800	2000	2800	2000	40	160	160
32	78	LS																0.0	280	280	280	240	240	2000	2000	2800	2000	2800	2000	40	160	160
33	84	85			9.0				1.0	6.0								8.6	280	280	280	240	240	2000	2000	2800	2000	2800	2000	40	160	160
34	85	LS			21.0								4.0					5.4	280	280	280	240	240	2000	2000	2800	2000	2800	2000	40	160	160
35	79	LS			5.0				5.0	9.0								12.4	280	280	280	240	240	2000	2000	2800	2000	2800	2000	40	160	160
36	LS	87			307.0													53.4	280	280		240	240	2000	2000	2800	2000	2800	2000	40	160	160
37	87	WWTP																0.0	280	280	280	240	240	2000	2000	2800	2000	2800	2000	40	160	160
TOTAL																																

TABLE SS-2



Cunningham Engineering Corp.
2940 Spafford Street, Suite 200
Davis, CA 95618

Design Criteria:
Infiltration Rate (all sizes) = 600 gal/acre/day
Mannings "n" = 0.013 Manning's formula $q=A(1.49/n)R^{2/3}S^{1/2}$
Peaking factor = see table

Project: Dunnigan SACOG REAP
Project No.: 1940.00
Location: Dunnigan, CA

Date: 2-Nov-22
Calc By: SM
Checked By: SG

Sewer Calculation Table

Inlet			ADF	Cum ADF	PF	Incr. I/I	Cum. I/I	Cum.	Cum.	Pipe Dia.	Pipe Slope	Q Full	d (ft)	d/D (%)	V (ft/s)	Vel.@ Q-Full	Inv. Up	Inv. Down	Ground Elev. Up	Ex. Ground Elev. Down	Pipe Cover Up	Pipe Cover Down	Length (ft)	Drop @ DS MH	CHANGE	CHANGE
Area	From	To	(mgd)	(mgd)	-	(mgd)	(mgd)	(mgd)	(cfs)	(in)	(ft/ft)	(cfs)			(ft/s)	(ft/s)	(ft)	(ft)	(ft)	(ft)	(ft)	(ft)	(ft)	(ft)		
1	0	1	0.024	0.024	3	0.0070	0.007	0.07903	0.12228	8	0.0035	0.71	0.18	27%	1.61	2.05	102.3	97.2	110	110	7.0	12.1	1450	0.00	0.00	0.00
2	1	2	0.062	0.086	3	0.0220	0.029	0.28706	0.44414	8	0.0035	0.71	0.37	56%	2.21	2.05	97.2	86.2	110	102	12.1	15.1	3150	0.00	0.00	0.00
3	2	3	0.010	0.096	3	0.0149	0.044	0.33223	0.51404	8	0.0035	0.71	0.41	62%	2.26	2.05	86.2	77.1	102	96	15.1	18.2	2600	0.10	0.00	0.10
4	3	4	0.000	0.096	3	0.0004	0.044	0.33346	0.51594	8	0.0045	0.81	0.38	57%	2.51	2.32	77.0	73.2	96	90	18.3	16.1	850	0.33	0.33	0.00
5	28	24	0.067	0.067	3	0.0265	0.026	0.22795	0.35268	8	0.0042	0.78	0.31	46%	2.25	2.24	101.3	89.1	109	97	7.0	7.2	2900	0.00	0.00	0.00
6	24	4	0.016	0.083	3	0.0299	0.056	0.30568	0.47296	8	0.0060	0.94	0.33	50%	2.71	2.68	89.1	73.2	97	90	7.2	16.1	2650	0.33	0.33	0.10
7	4	5	0.001	0.180	3	0.0011	0.102	0.64196	0.99325	12	0.0020	1.59	0.57	57%	2.15	2.03	72.9	71.2	90	86	16.1	13.8	850	0.00	0.00	0.00
8	25	5	0.025	0.025	3	0.0405	0.041	0.11695	0.18094	8	0.0035	0.71	0.23	34%	1.73	2.05	84.3	71.5	92	86	7.0	13.8	3650	0.33	0.33	0.10
9	5	6	0.000	0.206	3	0.0009	0.143	0.76061	1.17683	12	0.0020	1.59	0.63	63%	2.26	2.03	71.2	69.5	86	80	13.8	9.5	850	0.00	0.00	0.00
10	29	26	0.001	0.001	3	0.0027	0.003	0.00688	0.01065	8	0.0110	1.27	0.04	6%	1.25	3.63	82.3	77.3	90	85	7.0	7.0	450	0.10	0.00	0.10
11	26	6	0.018	0.019	3	0.0242	0.027	0.08462	0.13092	8	0.0037	0.73	0.19	28%	1.64	2.11	77.2	69.8	85	80	7.1	9.5	2000	0.33	0.33	0.10
12	6	7	0.000	0.225	3	0.0000	0.170	0.84523	1.30775	12	0.0053	2.59	0.50	50%	3.33	3.30	69.5	65.0	80	73	9.5	7.0	850	0.00	0.00	0.00
13	7	8	0.000	0.225	3	0.0000	0.170	0.84523	1.30775	12	0.0420	7.30	0.28	28%	7.27	9.30	65.0	56.6	73	73	7.0	15.4	200	0.25	0.25	0.10
14	37	36	0.002	0.002	3	0.0028	0.003	0.00784	0.01212	8	0.0248	1.90	0.03	5%	1.86	5.45	88.3	74.7	96	93	7.0	17.6	550	0.10	0.00	0.10
15	36	34	0.003	0.004	3	0.0049	0.008	0.02029	0.0314	8	0.0035	0.71	0.09	14%	1.03	2.05	74.6	68.1	93	90	17.7	21.2	1850	0.00	0.00	0.00
16	35	34	0.006	0.006	3	0.0109	0.011	0.02854	0.04416	8	0.0088	1.13	0.09	13%	1.66	3.25	82.3	68.2	90	90	7.0	21.1	1600	0.10	0.00	0.10
17	34	33	0.001	0.011	3	0.0025	0.021	0.0547	0.08463	8	0.0035	0.71	0.15	23%	1.39	2.05	68.1	63.2	90	77	21.2	13.1	1400	0.10	0.00	0.10
18	33	31	0.000	0.011	3	0.0000	0.021	0.0547	0.08463	8	0.0035	0.71	0.15	23%	1.39	2.05	63.1	62.2	77	75	13.2	12.1	250	0.10	0.00	0.10
19	32	31	0.008	0.008	3	0.0124	0.012	0.03761	0.0582	8	0.008	1.08	0.10	15%	1.77	3.10	71.3	62.1	79	75	7.0	12.2	1150	0.00	0.00	0.00
20	31	30	0.008	0.028	3	0.0066	0.040	0.12306	0.1904	8	0.0035	0.71	0.23	35%	1.75	2.05	62.1	60.2	75	76	12.2	15.1	550	0.10	0.00	0.10
21	30	8	0.017	0.044	3	0.0034	0.043	0.17682	0.27358	8	0.0035	0.71	0.28	42%	1.97	2.05	60.1	56.9	76	73	15.2	15.4	900	0.58	0.58	0.00
22	89	90	0.015	0.015	3	0.0135	0.013	0.05885	0.09105	8	0.0070	1.01	0.13	20%	1.83	2.90	87.0	77.2	95	85	7.3	7.1	1400	0.10	0.00	0.10
23	90	91	0.000	0.015	3	0.0000	0.013	0.05885	0.09105	8	0.0037	0.73	0.15	23%	1.50	2.11	77.1	71.4	85	80	7.2	7.9	1550	0.00	0.00	0.00
24	91	38	0.000	0.015	3	0.0000	0.013	0.05885	0.09105	8	0.0045	0.81	0.15	22%	1.60	2.32	71.4	63.3	80	71	7.9	7.0	1800	0.00	0.00	0.00
25	38	88	0.029	0.045	3	0.0095	0.023	0.15656	0.24223	8	0.0035	0.71	0.27	40%	1.86	2.05	63.3	59.3	71	68	7.0	8.0	1150	0.10	0.00	0.10
26	88	8	0.000	0.045	3	0.0000	0.023	0.15656	0.24223	8	0.0035	0.71	0.27	40%	1.86	2.05	59.2	56.9	68	73	8.1	15.4	650	0.58	0.58	0.10
27	8	WWTP	0.000	0.314	3	0.0000	0.236	1.1786	1.82356	15	0.0015	2.50	0.79	63%	2.24	2.04	56.3	55.3	73	72	15.5	15.5	650	0.00	0.00	0.00
28	83	82	0.017	0.017	3	0.0055	0.006	0.05519	0.08539	8	0.0035	0.71	0.15	23%	1.41	2.05	47.9	43.7	56	60	7.4	15.6	1200	0.10	0.00	0.10
29	82	80	0.007	0.023	3	0.0020	0.008	0.07739	0.11975	8	0.0035	0.71	0.18	27%	1.57	2.05	43.6	42.2	60	63	15.7	20.1	400	0.00	0.00	0.00
30	81	80	0.009	0.009	3	0.0040	0.004	0.03017	0.04669	8	0.0140	1.43	0.08	12%	1.97	4.10	54.2	42.3	62	63	7.1	20.0	850	0.10	0.00	0.10
31	80	78	0.011	0.043	3	0.0039	0.015	0.14519	0.22465	8	0.0035	0.71	0.25	38%	1.91	2.05	42.2	40.6	63	66	20.1	24.7	450	0.00	0.00	0.00
32	78	LS	0.000	0.043	3	0.0000	0.015	0.14519	0.22465	8	0.0035	0.71	0.25	38%	1.91	2.05	40.6	39.2	66	68	24.7	28.1	400	0.17	0.17	0.10
33	84	85	0.021	0.021	3	0.0052	0.005	0.06912	0.10694	8	0.0035	0.71	0.17	26%	1.48	2.05	53.1	51.0	61	65	7.2	13.3	600	0.00	0.00	0.00
34	85	LS	0.017	0.038	3	0.0033	0.008	0.12362	0.19126	8	0.0035	0.71	0.23	35%	1.76	2.05	51.0	48.2	65	68	13.3	19.1	800	0.17	0.17	0.00
35	79	LS	0.037	0.037	3	0.0075	0.007	0.11726	0.18143	8	0.0035	0.71	0.23	34%	1.73	2.05	58.3	53.7	66	68	7.0	13.6	1300	0.17	0.17	0.10
36	LS	87	0.000	0.118	3	0.0321	0.063	0.41814	0.64696	10	0.0025	1.10	0.46	55%	2.10	2.01	60.0	58.2	68	66	7.2	7.0	700	0.10	0.00	0.10
37	87	WWTP	0.000	0.118	3	0.0000	0.063	0.41814	0.64696	10	0.0025	1.10	0.46	55%	2.10	2.01	58.1	55.0	66	72	7.1	16.2	1250	0.00	0.00	0.00
TOTAL			0.432				1.59674									55.0										



Wastewater Management Fact Sheet

Membrane Bioreactors

INTRODUCTION

The technologies most commonly used for performing secondary treatment of municipal wastewater rely on microorganisms suspended in the wastewater to treat it. Although these technologies work well in many situations, they have several drawbacks, including the difficulty of growing the right types of microorganisms and the physical requirement of a large site. The use of microfiltration membrane bioreactors (MBRs), a technology that has become increasingly used in the past 10 years, overcomes many of the limitations of conventional systems. These systems have the advantage of combining a suspended growth biological reactor with solids removal via filtration. The membranes can be designed for and operated in small spaces and with high removal efficiency of contaminants such as nitrogen, phosphorus, bacteria, biochemical oxygen demand, and total suspended solids. The membrane filtration system in effect can replace the secondary clarifier and sand filters in a typical activated sludge treatment system. Membrane filtration allows a higher biomass concentration to be maintained, thereby allowing smaller bioreactors to be used.

APPLICABILITY

For new installations, the use of MBR systems allows for higher wastewater flow or improved treatment performance in a smaller space than a conventional design, i.e., a facility using secondary clarifiers and sand filters. Historically, membranes have been used for smaller-flow systems due to the high capital cost of the equipment and high operation and maintenance (O&M) costs. Today however, they are receiving increased use in larger systems. MBR systems are also well suited for some industrial and commercial applications. The high-quality effluent produced by MBRs makes them particularly applicable to reuse applications and for surface

water discharge applications requiring extensive nutrient (nitrogen and phosphorus) removal.

ADVANTAGES AND DISADVANTAGES

The advantages of MBR systems over conventional biological systems include better effluent quality, smaller space requirements, and ease of automation. Specifically, MBRs operate at higher volumetric loading rates which result in lower hydraulic retention times. The low retention times mean that less space is required compared to a conventional system. MBRs have often been operated with longer solids residence times (SRTs), which results in lower sludge production; but this is not a requirement, and more conventional SRTs have been used (Crawford et al. 2000). The effluent from MBRs contains low concentrations of bacteria, total suspended solids (TSS), biochemical oxygen demand (BOD), and phosphorus. This facilitates high-level disinfection. Effluents are readily discharged to surface streams or can be sold for reuse, such as irrigation.

The primary disadvantage of MBR systems is the typically higher capital and operating costs than conventional systems for the same throughput. O&M costs include membrane cleaning and fouling control, and eventual membrane replacement. Energy costs are also higher because of the need for air scouring to control bacterial growth on the membranes. In addition, the waste sludge from such a system might have a low settling rate, resulting in the need for chemicals to produce biosolids acceptable for disposal (Hermanowicz et al. 2006). Fleischer et al. 2005 have demonstrated that waste sludges from MBRs can be processed using standard technologies used for activated sludge processes.

MEMBRANE FILTRATION

Membrane filtration involves the flow of water-containing pollutants across a membrane. Water permeates through the membrane into a separate channel for recovery (Figure 1). Because of the cross-flow movement of water and the waste constituents, materials left behind do not accumulate at the membrane surface but are carried out of the system for later recovery or disposal. The water passing through the membrane is called the *permeate*, while the water with the more-concentrated materials is called the *concentrate* or *retentate*.

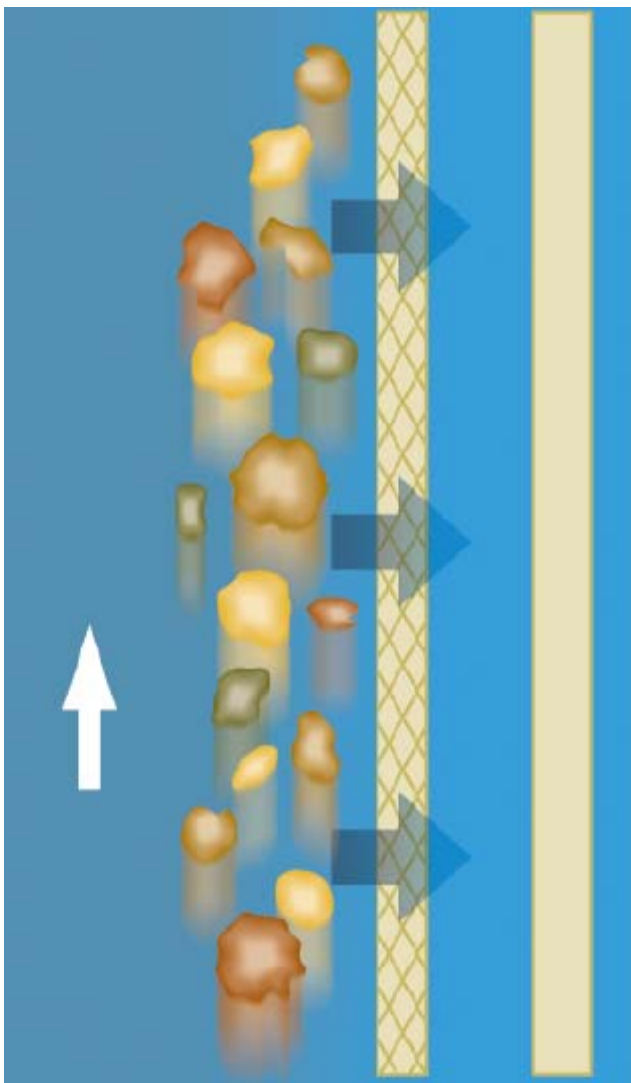

Figure 1. Membrane filtration process (Image from Siemens/U.S. Filter)

Membranes are constructed of cellulose or other polymer material, with a maximum pore size set during the manufacturing process. The require-

ment is that the membranes prevent passage of particles the size of microorganisms, or about 1 micron (0.001 millimeters), so that they remain in the system. This means that MBR systems are good for removing solid material, but the removal of dissolved wastewater components must be facilitated by using additional treatment steps.

Membranes can be configured in a number of ways. For MBR applications, the two configurations most often used are hollow fibers grouped in bundles, as shown in Figure 2, or as flat plates. The hollow fiber bundles are connected by manifolds in units that are designed for easy changing and servicing.



Figure 2. Hollow-fiber membranes (Image from GE/Zenon)

DESIGN CONSIDERATIONS

Designers of MBR systems require only basic information about the wastewater characteristics, (e.g., influent characteristics, effluent requirements, flow data) to design an MBR system. Depending on effluent requirements, certain supplementary options can be included with the MBR system. For example, chemical addition (at various places in the treatment chain, including: before the primary settling tank; before the secondary settling tank [clarifier]; and before the MBR or final filters) for phosphorus removal can be included in an MBR system if needed to achieve low phosphorus concentrations in the effluent.

MBR systems historically have been used for small-scale treatment applications when portions of the treatment system were shut down and the

wastewater routed around (or bypassed) during maintenance periods.

However, MBR systems are now often used in full-treatment applications. In these instances, it is recommended that the installation include one additional membrane tank/unit beyond what the design would nominally call for. This “N plus 1” concept is a blend between conventional activated sludge and membrane process design. It is especially important to consider both operations and maintenance requirements when selecting the number of units for MBRs. The inclusion of an extra unit gives operators flexibility and ensures that sufficient operating capacity will be available (Wallis-Lage et al. 2006). For example, bioreactor sizing is often limited by oxygen transfer, rather than the volume required to achieve the required SRT—a factor that significantly affects bioreactor numbers and sizing (Crawford et al. 2000).

Although MBR systems provide operational flexibility with respect to flow rates, as well as the ability to readily add or subtract units as conditions dictate, that flexibility has limits. Membranes typically require that the water surface be maintained above a minimum elevation so that the membranes remain wet during operation. Throughput limitations are dictated by the physical properties of the membrane, and the result is that peak design flows should be no

more than 1.5 to 2 times the average design flow. If peak flows exceed that limit, either additional membranes are needed simply to process the peak flow, or equalization should be included in the overall design. The equalization is done by including a separate basin (external equalization) or by maintaining water in the aeration and membrane tanks at depths higher than those required and then removing that water to accommodate higher flows when necessary (internal equalization).

DESIGN FEATURES

Pretreatment

To reduce the chances of membrane damage, wastewater should undergo a high level of debris removal prior to the MBR. Primary treatment is often provided in larger installations, although not in most small to medium sized installations, and is not a requirement. In addition, all MBR systems require 1- to 3-mm-cutoff fine screens immediately before the membranes, depending on the MBR manufacturer. These screens require frequent cleaning. Alternatives for reducing the amount of material reaching the screens include using two stages of screening and locating the screens after primary settling.

Membrane Location

MBR systems are configured with the mem-

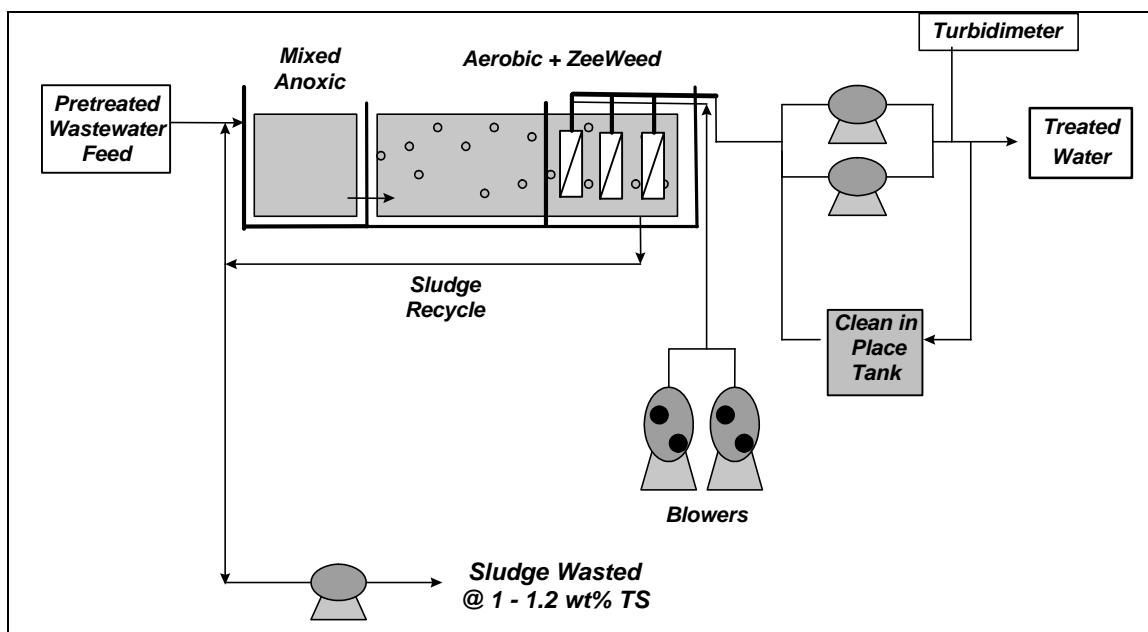

Figure 3. Immersed membrane system configuration (Image from GE/Zenon)

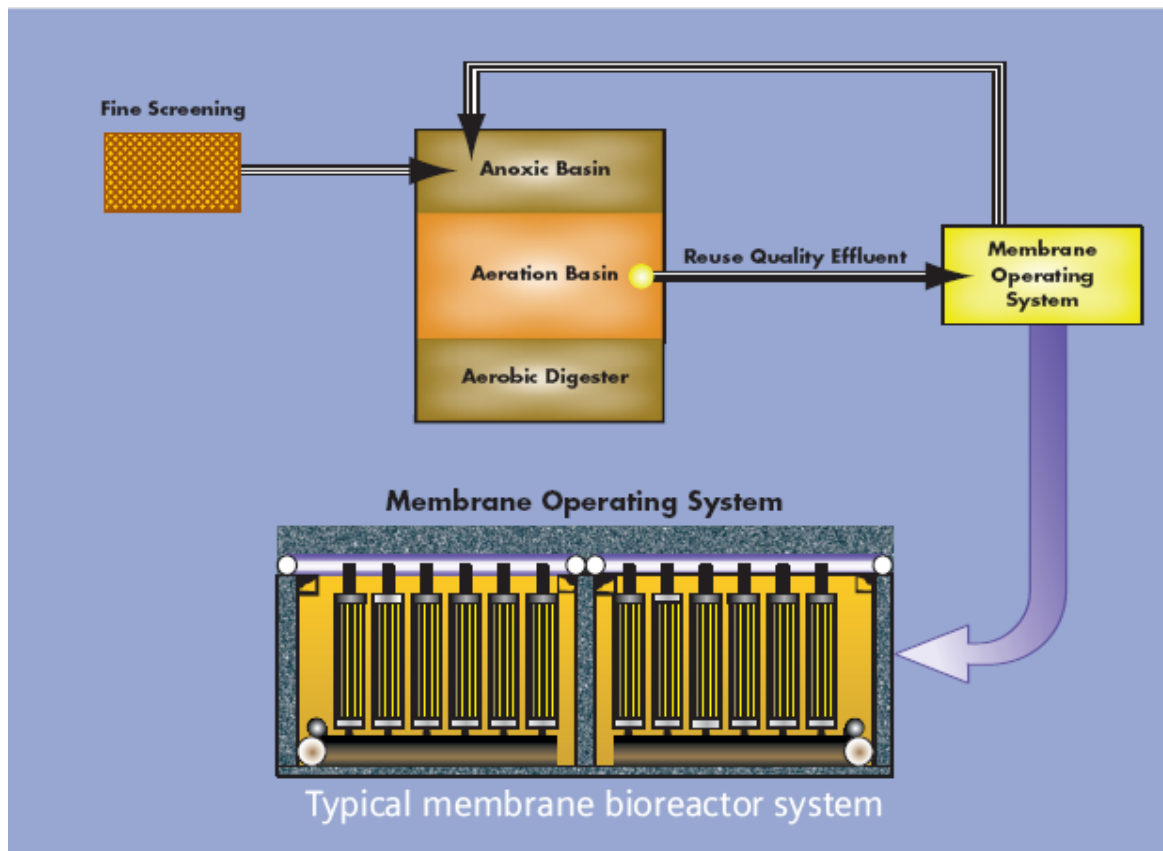

Figure 4. External membrane system configuration (Image from Siemens/U.S. Filter)

branes actually immersed in the biological reactor or, as an alternative, in a separate vessel through which mixed liquor from the biological reactor is circulated. The former configuration is shown in Figure 3; the latter, in Figure 4.

Membrane Configuration

MBR manufacturers employ membranes in two basic configurations: hollow fiber bundles and plate membranes. Siemens/U.S.Filter's Memjet and Memcor systems, GE/Zenon's ZeeWeed and ZenoGem systems, and GE/Ionics' system use hollow-fiber, tubular membranes configured in bundles. A number of bundles are connected by manifolds into units that can be readily changed for maintenance or replacement. The other configuration, such as those provided by Kubota/Enviroquip, employ membranes in a flat-plate configuration, again with manifolds to allow a number of membranes to be connected in readily changed units. Screening requirements for both systems differ: hollow-fiber membranes typically require 1- to 2-mm screening, while

plate membranes require 2- to 3-mm screening (Wallis-Lage et al. 2006).

System Operation

All MBR systems require some degree of pumping to force the water flowing through the membrane. While other membrane systems use a pressurized system to push the water through the membranes, the major systems used in MBRs draw a vacuum through the membranes so that the water outside is at ambient pressure. The advantage of the vacuum is that it is gentler to the membranes; the advantage of the pressure is that throughput can be controlled. All systems also include techniques for continually cleaning the system to maintain membrane life and keep the system operational for as long as possible. All the principal membrane systems used in MBRs use an air scour technique to reduce buildup of material on the membranes. This is done by blowing air around the membranes out of the manifolds. The GE/Zenon systems use air scour, as well as a back-pulsing technique, in which permeate is occasionally pumped back

into the membranes to keep the pores cleared out. Back-pulsing is typically done on a timer, with the time of pulsing accounting for 1 to 5 percent of the total operating time.

Downstream Treatment

The permeate from an MBR has low levels of suspended solids, meaning the levels of bacteria, BOD, nitrogen, and phosphorus are also low. Disinfection is easy and might not be required, depending on permit requirements..

The solids retained by the membrane are recycled to the biological reactor and build up in the system. As in conventional biological systems, periodic sludge wasting eliminates sludge buildup and controls the SRT within the MBR system. The waste sludge from MBRs goes through standard solids-handling technologies for thickening, dewatering, and ultimate disposal. Hermanowicz et al. (2006) reported a decreased ability to settle in waste MBR sludges due to increased amounts of colloidal-size particles and filamentous bacteria. Chemical addition increased the ability of the sludges to settle. As more MBR facilities are built and operated, a more definitive understanding of the characteristics of the resulting biosolids will be achieved. However, experience to date indicates that conventional biosolids processing unit operations are also applicable to the waste sludge from MBRs.

Membrane Care

The key to the cost-effectiveness of an MBR system is membrane life. If membrane life is curtailed such that frequent replacement is required, costs will significantly increase. Membrane life can be increased in the following ways:

- Good screening of larger solids before the membranes to protect the membranes from physical damage.
- Throughput rates that are not excessive, i.e., that do not push the system to the limits of the design. Such rates reduce the amount of material that is forced into the membrane and thereby reduce the amount that has to be re-

moved by cleaners or that will cause eventual membrane deterioration.

- Regular use of mild cleaners. Cleaning solutions most often used with MBRs include regular bleach (sodium) and citric acid. The cleaning should be in accord with manufacturer-recommended maintenance protocols.

Membrane Guarantees

The length of the guarantee provided by the membrane system provider is also important in determining the cost-effectiveness of the system. For municipal wastewater treatment, longer guarantees might be more readily available compared to those available for industrial systems. Zenon offers a 10-year guarantee; others range from 3 to 5 years. Some guarantees include cost prorating if replacement is needed after a certain service time. Guarantees are typically negotiated during the purchasing process. Some manufacturers' guarantees are tied directly to screen size: longer membrane warranties are granted when smaller screens are used (Wallis-Lage et al. 2006). Appropriate membrane life guarantees can be secured using appropriate membrane procurement strategies (Crawford et al. 2002).

SYSTEM PERFORMANCE

Siemens/U.S. Filter Systems

Siemens/U.S.Filter offers MBR systems under the Memcor and Memjet brands. Data provided by U.S. Filter for its **Calls Creek (Georgia) facility** are summarized below. The system, as Calls Creek retrofitted it, is shown in Figure 5. In essence, the membrane filters were used to replace secondary clarifiers downstream of an Orbal oxidation ditch. The system includes a fine screen (2-mm cutoff) for inert solids removal just before the membranes.

The facility has an average flow of 0.35 million gallons per day (mgd) and a design flow of 0.67 mgd. The system has 2 modules, each containing 400 units, and each unit consists of a cassette with manifold-connected membranes. As shown in Table 1, removal of BOD, TSS, and ammonia-nitrogen is excellent; BOD and TSS in the effluent are around the detection limit. Phosphorus is also removed well in the system, and the effluent

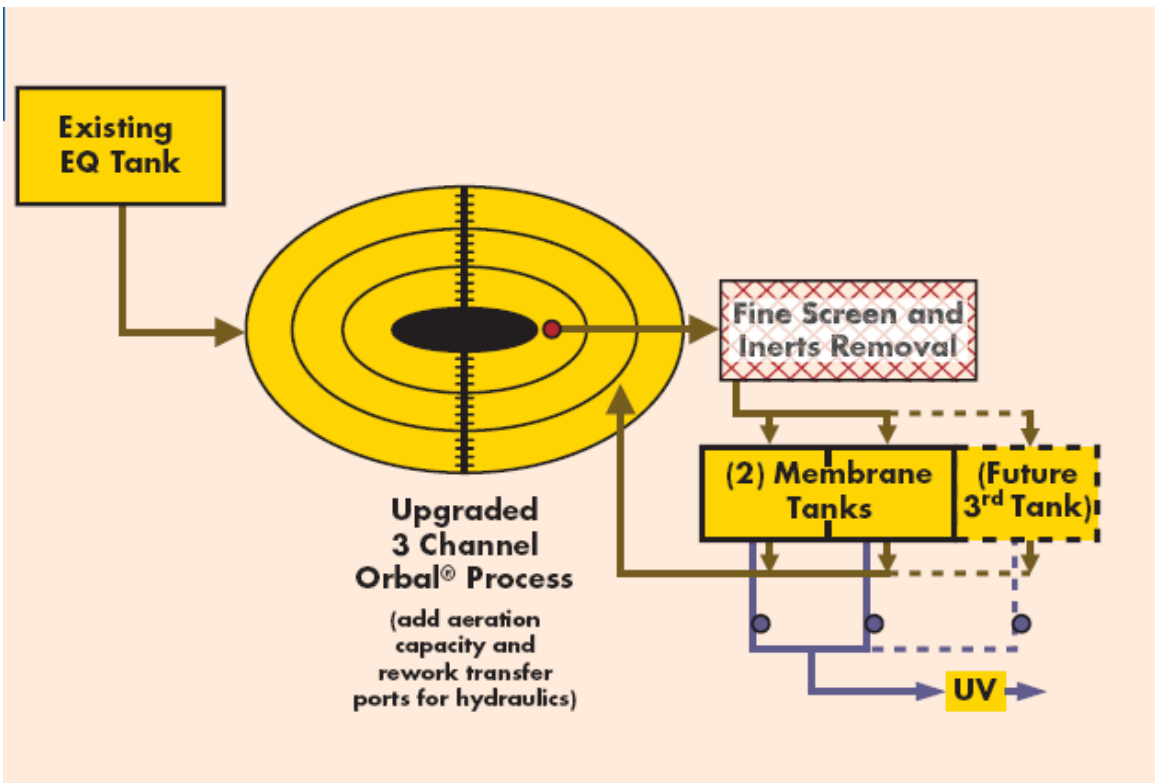

Figure 5. Calls Creek flow diagram (courtesy of Siemens/U.S. Filter)

Table 1.
Calls Creek results 2005

Parameter	Influent	Effluent		
	Average	Average	Max Month	Min Month
Flow (mgd)	0.35	--	0.44	0.26
BOD (mg/L)	145	1	1	1
TSS (mg/L)	248	1	1	1
Ammonia-N (mg/L)	14.8	0.21	0.72	0.10
P (mg/L)	0.88	0.28	0.55	0.12
Fecal coliforms (#/100 mL)	--	14.2	20	0
Turbidity (NTU)	--	0.30	1.31	0.01

has very low turbidity. The effluent has consistently met discharge limits.

Zenon Systems

General Electric/Zenon provides systems under the ZenoGem and ZeeWeed brands. The ZeeWeed brand refers to the membrane, while ZenoGem is the process that uses ZeeWeed.

Performance data for two installed systems are shown below.

Cauley Creek, Georgia. The Cauley Creek facility in Fulton County, Georgia, is a 5-mgd wastewater reclamation plant. The system includes biological phosphorus removal, mixed liquor surface wasting, and sludge thickening using a ZeeWeed system to minimize the required volume of the aerobic digester, according to information provided by GE. Ultraviolet disinfection is employed to meet regulatory limits. Table 2 shows that the removal for all parame-

Table 2.
Cauley Creek, Georgia, system performance

Parameter	Influent Average	Effluent		
		Average	Max Month	Min Month
Flow (mgd)	4.27	--	4.66	3.72
BOD (mg/L)	182	2.0	2.0	2.0
COD (mg/L)	398	12	22	5
TSS (mg/L)	174	3.2	5	3
TKN (mg/L)	33.0	1.9	2.9	1.4
Ammonia-N (mg/L)	24.8	0.21	0.29	0.10
TP (mg/L)	5.0	0.1	0.13	0.06
Fecal coliforms (#/100 mL)	--	2	2	2
NO3-N (mg/L)	--	2.8		

ters is over 90 percent. The effluent meets all permit limits, and is reused for irrigation and lawn watering.

Traverse City, Michigan. The Traverse City Wastewater Treatment Plant (WWTP) went through an upgrade to increase plant capacity and produce a higher-quality effluent, all within the facility's existing plant footprint (Crawford et al. 2005). With the ZeeWeed system, the facility was able to achieve those goals. As of 2006, the plant is the largest-capacity MBR facility in North America. It has a design average annual flow of 7.1 mgd, maximum monthly flow of 8.5 mgd, and peak hourly flow of 17 mgd. The membrane system consists of a 450,000-gallon tank with eight compartments of equal size. Secondary sludge is distributed evenly to the compartments. Blowers for air scouring, as well as permeate and back-pulse pumps, are housed in a nearby building.

Table 3 presents a summary of plant results over a 12-month period. The facility provides excellent removal of BOD, TSS, ammonia-nitrogen, and phosphorus. Figure 6 shows the influent, effluent, and flow data for the year.

Operating data for the Traverse City WWTP were obtained for the same period. The mixed liquor suspended solids over the period January to August averaged 6,400 mg/L, while the mixed liquor volatile suspended solids averaged 4,400 mg/L. The energy use for the air-scouring blow-

ers averaged 1,800 kW-hr/million gallons (MG) treated.

COSTS

Capital Costs

Capital costs for MBR systems historically have tended to be higher than those for conventional systems with comparable throughput because of the initial costs of the membranes. In certain situations, however, including retrofits, MBR systems can have lower or competitive capital costs compared with alternatives because MBRs have lower land requirements and use smaller tanks, which can reduce the costs for concrete. U.S. Filter/Siemen's Memcor package plants have installed costs of \$7–\$20/gallon treated.

Fleischer et al. (2005) reported on a cost comparison of technologies for a 12-MGD design in Loudoun County, Virginia. Because of a chemical oxygen demand limit, activated carbon adsorption was included with the MBR system. It was found that the capital cost for MBR plus granular activated carbon at \$12/gallon treated was on the same order of magnitude as alternative processes, including multiple-point alum addition, high lime treatment, and post-secondary membrane filtration.

Operating Costs

Operating costs for MBR systems are typically higher than those for comparable conventional systems. This is because of the higher energy

Table 3.
Summary of Traverse City, Michigan, Performance Results

Parameter	Influent	Effluent		
	Average	Average	Max Month	Min Month
Flow (mgd)	4.3	--	5.1	3.6
BOD (mg/L)	280	< 2	< 2	< 2
TSS (mg/L)	248	< 1	< 1	< 1
Ammonia-N (mg/L)	27.9	< 0.08	< 0.23	< 0.03
TP (mg/L)	6.9	0.7	0.95	0.41
Temperature (deg C)	17.2	--	23.5	11.5

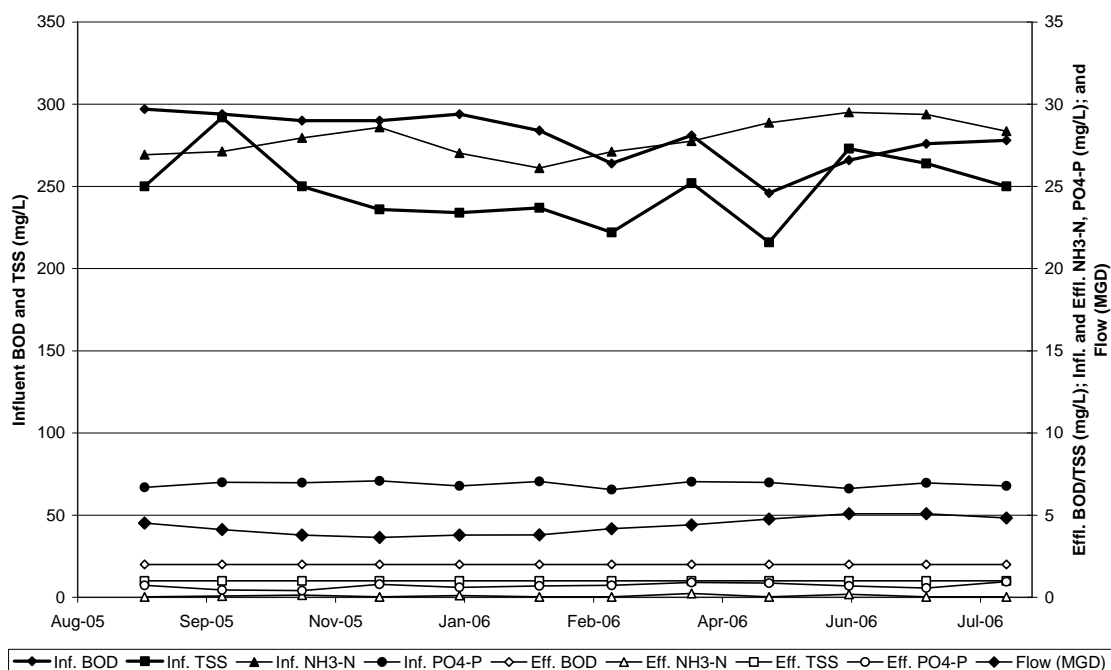

Figure 6. Performance of the Traverse City plant

costs if air scouring is used to reduce membrane fouling. The amount of air needed for the scouring has been reported to be twice that needed to maintain aeration in a conventional activated sludge system (Scott Blair, personal communication, 2006). These higher operating costs are often partially offset by the lower costs for sludge disposal associated with running at longer sludge residence times and with membrane thickening/dewatering of wasted sludge.

Fleischer et al. (2005) compared operating costs. They estimated the operating costs of an MBR system including activated carbon adsorption at \$1.77 per 1,000 gallons treated. These costs were

of the same order of magnitude as those of alternative processes, and they compared favorably to those of processes that are chemical-intensive, such as lime treatment.

ACKNOWLEDGMENTS

The authors acknowledge Dr. Venkat Mahendrakar, GE/Zenon, Mr. John Irwin, Siemens/U.S. Filter, and Mr. Scott Blair and Mr. Leroy Bonkoski of the Traverse City WWTP for their assistance in obtaining data and system information. EPA acknowledges external peer

reviewers Pat Brooks, Alan Cooper, and Glenn Daigger for their contribution.

PRODUCT LITERATURE USED

Enviroquip/Kubota. Sales literature.

Siemens. Product literature.

<http://www.usfilter.com/en/Product+Lines/Envirex_Products/Envirex_Products/envirex_mbr_xpress_packaged_plant.htm>.

Zenon. Case studies: Cauley Creek, Georgia.

<http://www.zenon.com/resources/case_studies/water_reuse/CauleyCreek.shtml>.

Zenon. Case studies: Traverse City, Michigan.

<http://www.zenon.com/resources/case_studies/wastewater/TraverseCity.shtml>.

REFERENCES

Crawford, G., G. Daigger, J. Fisher, S. Blair, and R. Lewis. 2005. Parallel Operation of Large Membrane Bioreactors at Traverse City. In *Proceedings of the Water Environment Federation 78th Annual Conference & Exposition*, Washington, DC, CD-ROM, October 29–Nov 2, 2005.

Crawford, G., A. Fernandez, A. Shawwa, and G. Daigger. 2002. Competitive Bidding and Evaluation of Membrane Bioreactor Equipment—Three Large Plant Case Studies. In *Proceedings of the Water Environment Federation 75th Annual Conference & Exposition*, Chicago, IL, CD-ROM, September 28–Oct 2, 2002.

Crawford, G., D. Thompson, J. Lozier, G. Daigger, and E. Fleischer. 2000. Membrane Bioreactors—A Designer's Perspective. In *Proceedings of the Water Environment Federation 73rd Annual Conference & Exposition on Water Quality and Wastewater Treatment*, Anaheim, CA, CD-ROM, October 14-18, 2000.

Fleischer, E.J., T.A. Broderick, G.T. Daigger, A. D. Fonseca, R.D. Holbrook, and S.N. Murthy. 2005. Evaluation of Membrane Bioreactor Process Capabilities to Meet Stringent Effluent Nutrient Discharge Requirements. *Water Environment Research* 77:162–178.





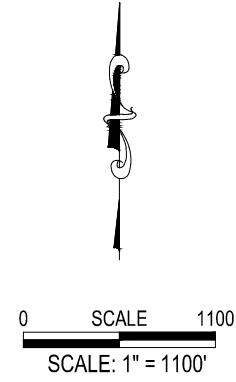
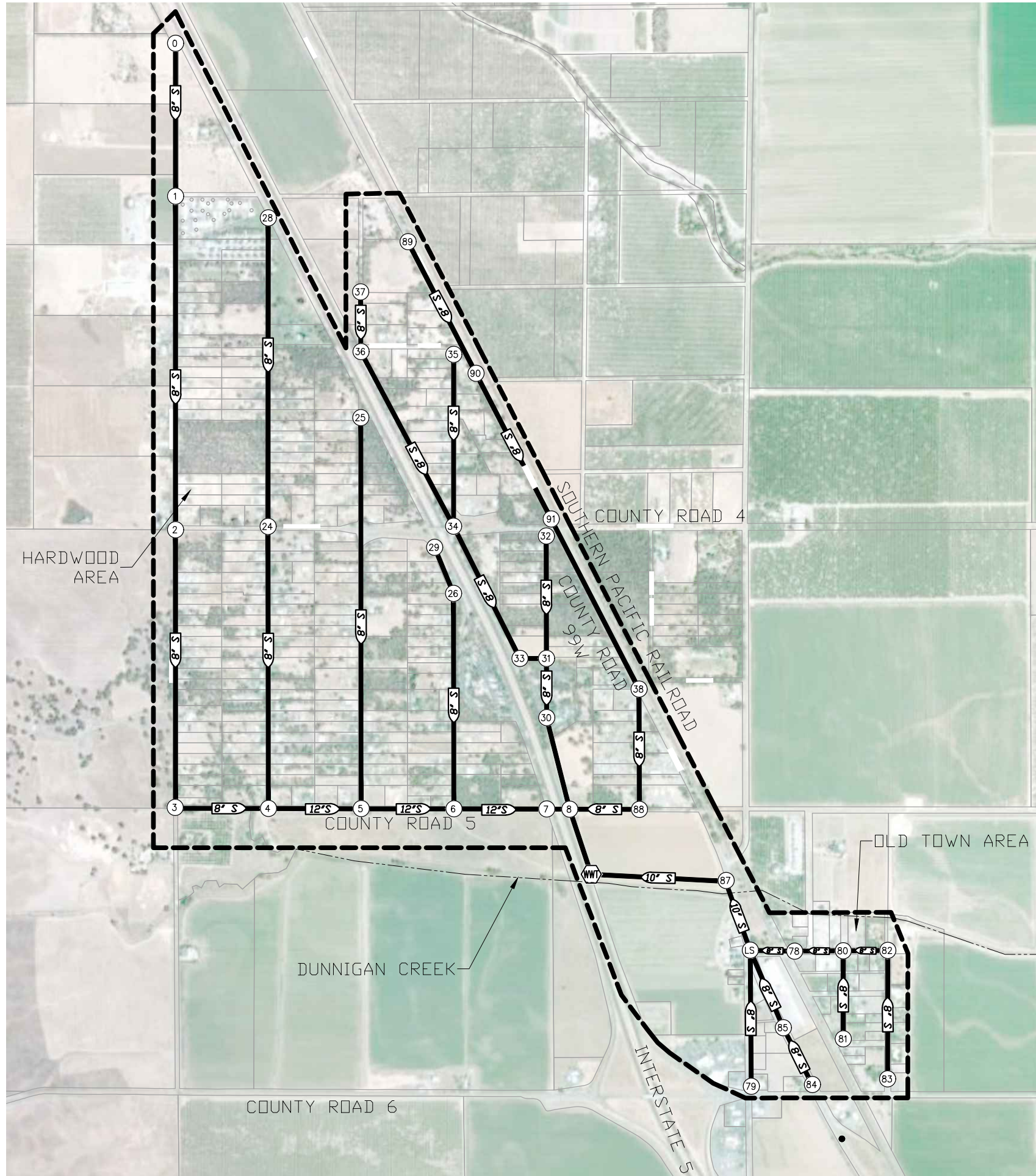

Fleischer, E. J., T. A. Broderick, G. T. Daigger, J. C. Lozier, A. M. Wollmann, and A. D. Fonseca. 2001. Evaluating the Next Generation of Water Reclamation Processes. In *Proceedings of the Water Environment Federation 74th Annual Conference & Exposition*, Atlanta, GA, CD-ROM, October 13–17, 2001.

Hermanowicz, S.W., D. Jenkins, R.P. Merlo, and R.S. Trussell. 2006. *Effects of Biomass Properties on Submerged Membrane Bioreactor (SMBR) Performance and Solids Processing*. Document no. 01-CTS-19UR. Water Environment Federation.

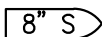
Metcalf & Eddy. 2003. *Wastewater Engineering, Treatment and Reuse*. 4th ed. McGraw-Hill, New York.

Wallis-Lage, C., B. Hemken, et al. 2006. *MBR Plants: Larger and More Complicated*. Presented at the Water Reuse Association's 21st Annual Water Reuse Symposium, Hollywood, CA, September 2006.



- LEGEND**
-  PROPOSED SANITARY SEWER
 -  PRELIMINARY PIPE SIZE
 -  EXISTING PARCEL
 -  PROPOSED 1.6 MGD MBR WASTEWATER TREATMENT PLANT
 -  STUDY AREA
 -  DUNNIGAN CREEK
 -  PROPOSED LIFT STATION

**DUNNIGAN SEWER AND WATER FEASIBILITY STUDY
EXHIBIT E: PROPOSED SEWER**

DESIGNED SG
 DRAWN SM
 CHECKED SG

SCALE
 1" = 1100'
 SHEET
 1
 OF
 1

DATE: 11/02/22
 JOB No: 1940.01



CECWEST.COM

Project Planning ■ Civil Engineering ■ Landscape Architecture

Sacramento Office ■ Davis Office

2120 20th Street, Suite Three 2940 Spafford Street, Suite 200
 Sacramento, CA 95818 Davis, CA 95618
 (916) 455-2026 (530) 758-2026

CALIFORNIA

YOLO



DUNNIGAN SEWER AND WATER FEASIBILITY STUDY
 WATER DEMAND SUMMARY (DENSIFIED LAND USE)
 DUNNIGAN, YOLO, CA
 DATE: 17-Nov-22

Proposed Land Use	Area (Acres)	Demand Factor Units	Total Units	Average Day Water Demand (gallons/day/Demand Factor Unit)	Average Day Water Demand (gallons/day/Demand Factor Unit) (20% Reduced *)	Average Day Water Demand (Gallons per day)	Peaking Factor (Max Day)	Peaking Factor (Peak Hour)	Max Day Demand (Gallons per day)	Peak Hour Demand (GPH)
RR-2	298.71	Dwelling Unit	358	728	582.4	208,499	2	1.7	416,998	29,537
R-L	99.66	Dwelling Unit	595	728	582.4	346,528	2	1.7	693,056	49,091
R-M	27.54	Dwelling Unit	390	521	416.8	162,552	2	1.7	325,104	23,028
C-H	14.62	Acres	15	2598	2078.4	30,386	2	1.7	60,772	4,305
C-L	15.80	Acres	18	2598	2078.4	32,839	2	1.7	65,678	4,652
PQP	4.31	Acres	3	1780	1424.0	6,137	2	1.7	12,274	869
I-H	20.20	Acres	21	2598	2078.4	41,984	2	1.7	83,968	5,948
I-L	0.00	Acres	0	2598	2078.4	0	2	1.7	0	0
				Sum		828,925			1,657,850	117,430

0.8 MGD	1.7 MGD
575.6 GPM	1,151.3 GPM
302.6 Yearly (MG)	605.1 Yearly (MG)
929 Acre-foot	1857 Acre-foot

* use of water E friendly fixtures

Storage Tank Calculation

Max Day Demand (MDD)	1657850.0 Gallons	
Operational Storage	0.4 MG	25% of MDD
Fire Water Demand	0.4 MG	Considering 3500 GPM for 2 hours
Emergency Storage	0.8 MG	Considering 12 hrs supply of MDD
Total Storage Tank	1.7 MG	

Treatment Plant

Standard water treatment capacity	1150.0 GPM
-----------------------------------	------------



DUNNIGAN SEWER AND WATER FEASIBILITY STUDY
 WATER DEMAND SUMMARY (EXISTING LAND USE)
 DUNNIGAN, YOLO, CA
 DATE: 17-Nov-22

Proposed Land Use	Area (Acres)	Demand Factor Units	Total Units	Average Day Water Demand (gallons/day/Demand Factor Unit)	Average Day Water Demand (gallons/day/Demand Factor Unit) (20% Reduced *)	Average Day Water Demand (Gallons per day)	Peaking Factor (Max Day)	Peaking Factor (Peak Hour)	Max Day Demand (Gallons per day)	Peak Hour Demand (GPH)
RR-2	234.69	Dwelling Unit	243	728	582.4	141,523	2	1.7	283,046	20,049
R-L	17.2	Dwelling Unit	87	728	582.4	50,669	2	1.7	101,338	7,178
R-M	27.54	Dwelling Unit	390	521	416.8	162,552	2	1.7	325,104	23,028
C-H	14.62	Acres	15	2598	2078.4	30,386	2	1.7	60,772	4,305
C-L	14.96	Acres	16	2598	2078.4	31,093	2	1.7	62,186	4,405
PQP	4.31	Acres	3	1780	1424.0	6,137	2	1.7	12,274	869
I-H	20.20	Acres	21	2598	2078.4	41,984	2	1.7	83,968	5,948
I-L	0.00	Acres	0	2598	2078.4	0	2	1.7	0	0
				Sum		464,344			928,688	65,782

0.5 MGD
322.5 GPM
169.5 Yearly (MG)
520 Acre-foot

0.9 MGD
644.9 GPM
339.0 Yearly (MG)
1040 Acre-foot

* use of water E friendly fixtures

Storage Tank Calculation

Max Day Demand (MDD)	928688.0 Gallons	
Operational Storage	0.2 MG	25% of MDD
Fire Water Demand	0.4 MG	Considering 3500 GPM for 2 hours
Emergency Storage	0.5 MG	Considering 12 hrs supply of MDD
Total Storage Tank	1.1 MG	

Treatment Plant

Standard water treatment capacity	650.0 GPM
-----------------------------------	-----------

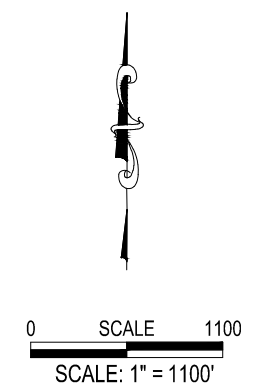
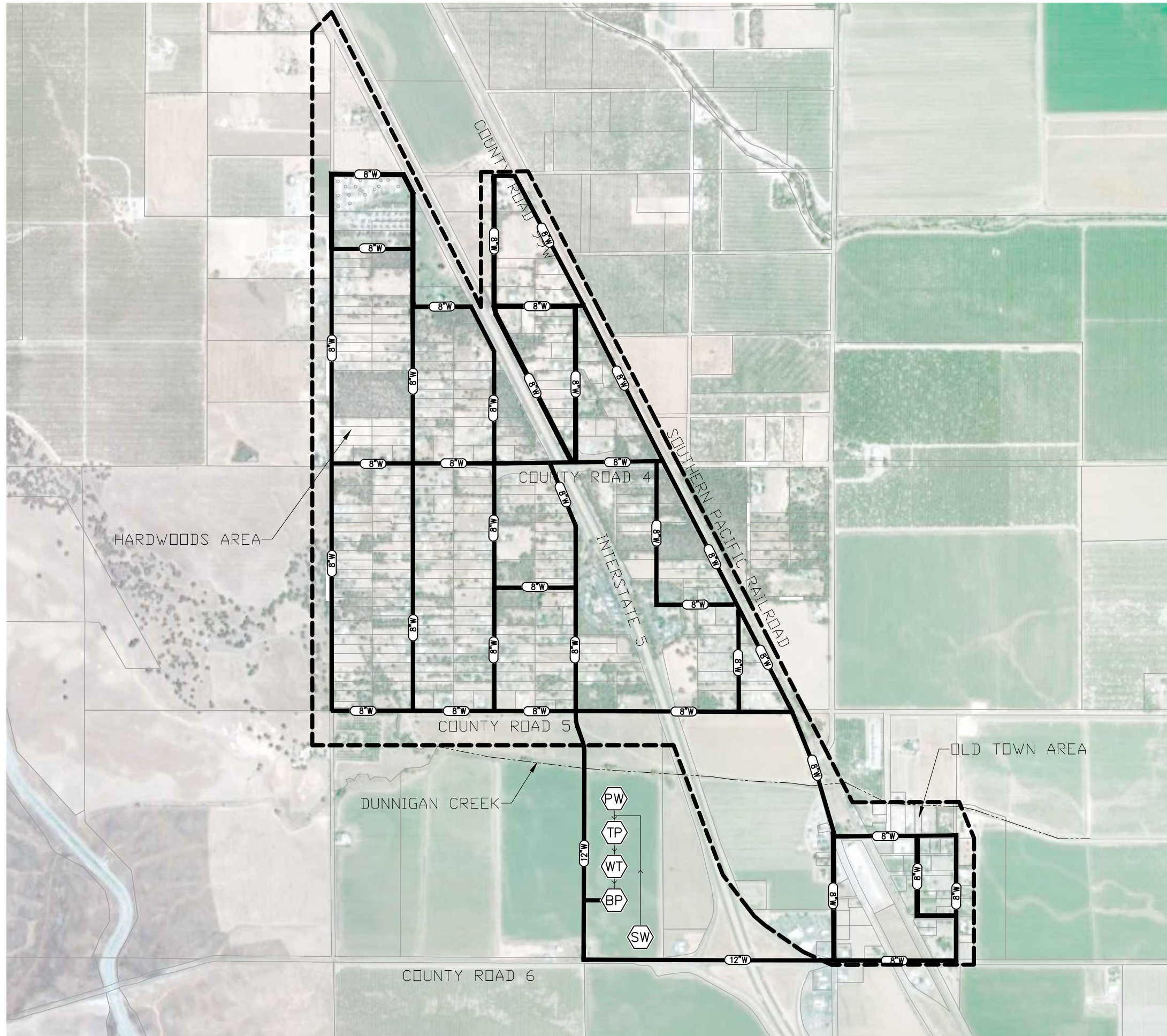

- LEGEND**
- PROPOSED WATER MAIN
 - (12"W) PRELIMINARY PIPE SIZE
 - EXISTING PARCEL
 - (PW) PRIMARY WELL
 - (SW) SECONDARY WELL (FOR REDUNDANCY)
 - (TP) PROPOSED WATER TREATMENT PLANT
 - (WT) PROPOSED WATER TANK
 - (BP) PROPOSED BOOSTER PUMP

NOTE: THE PIPING NETWORK SHOWN FOR THE WELLS, TREATMENT PLANT, AND WATER TANK ARE SCHEMATIC IN NATURE AND DO NOT REFLECT ACTUAL PROPOSED PIPING LOCATIONS.

DUNNIGAN SEWER AND WATER FEASIBILITY STUDY
EXHIBIT G: PROPOSED WATER

DESIGNED	SG
DRAWN	SM
CHECKED	SG
SCALE	
1" = 1100'	
SHEET	
1	
OF	
1	
DATE:	11/02/22
JOB No:	1940.01

CECWEST.COM

Project Planning ■ Civil Engineering ■ Landscape Architecture

■ Sacramento Office

2120 20th Street, Suite Three
Sacramento, CA 95818
(916) 455-2026

■ Davis Office

2940 Spafford Street, Suite 200
Davis, CA 95618
(530) 758-2026

YOLO CALIFORNIA



ENGINEER'S OPINION OF PROBABLE CONSTRUCTION COSTS
PROJECT: DUNNIGAN SEWER AND WATER FEASIBILITY STUDY
PURPOSE: CLIENT REVIEW
DATE: 11/02/2022

ITEM	DESCRIPTION	QTY	UNIT	UNIT COST	TOTAL COST
I. SEWER SYSTEM					
A. COLLECTION					
1.	8" SDR-35	41,101	LF	\$107	\$4,398,000
2.	10" SDR-35	1,951	LF	\$135	\$263,000
3.	12" SDR-35	2,829	LF	\$157	\$444,000
4.	15" SDR-35	646	LF	\$105	\$68,000
5.	48" SEWER MANHOLE	116	EA	\$6,235	\$723,000
6.	4" SEWER SERVICE	350	EA	\$1,500	\$525,000
7.	CLEAN-OUT	350	EA	\$1,853	\$649,000
8.	LIFT STATION	1	EA	\$500,000	\$500,000
8.	JACK AND BORE	839	LF	\$1,000	\$839,000
	SEWER COLLECTION SYSTEM SUB-TOTAL				\$8,409,000
B. TREATMENT					
9.	MBR WWTP	1	EA	\$12,000,000	\$12,000,000
	SEWER TREATMENT SUB-TOTAL				\$12,000,000
II. WATER SYSTEM					
A. TREATMENT					
10.	GROUNDWATER WELL	2	EA	\$1,500,000	\$3,000,000
11.	WATER TREATMENT PLANT (1200 GPM CAPACITY)	1	EA	\$3,200,000	\$3,200,000
12.	BOOSTER PUMPS (INCLUDES 2 BACKUP PUMPS)	4	EA	\$200,000	\$800,000
13.	WATER TANK	2	MG	\$2,500,000	\$4,250,000
	WATER TREATMENT SUB-TOTAL				\$11,250,000
B. DISTRIBUTION					
14.	8" PVC C900 Class 200	54,302	LF	\$130	\$7,059,000
15.	12" PVC C900 Class 200	4,961	LF	\$152	\$754,000
16.	8" GATE VALVE	23	EA	\$2,077	\$47,000
17.	12" BUTTERFLY VALVE	23	EA	\$2,970	\$67,000
18.	1.5" METER ASSEMBLY	352	EA	\$2,288	\$805,000
19.	1.5" BACKFLOW ASSEMBLY	352	EA	\$1,668	\$587,000
20.	FIRE HYDRANT AND ASSEMBLY	70	EA	\$11,265	\$793,000
21.	JACK AND BORE	1,289	LF	\$1,000	\$1,289,000
	WATER DISTRIBUTION SUB-TOTAL				\$12,786,000

SUMMARY

I.A.	SEWER COLLECTION SYSTEM	\$8,409,000
I.B.	SEWER TREATMENT SYSTEM	\$12,000,000
II.A.	WATER TREATMENT SYSTEM	\$11,250,000
II.B.	WATER DISTRIBUTION	\$12,786,000
	SUB-TOTAL:	\$44,445,000
	25% DESIGN CONTINGENCY:	\$11,111,000
	10% CONSTRUCTION CONTINGENCY:	\$4,445,000
	TOTAL SEWER/WATER COST :	\$60,000,000

NOTES:

- (1) COST OPINION EXCLUDES COSTS ASSOCIATED WITH LAND ACQUISITION.
 In providing opinions of probable construction cost, the Client understands that the Engineer has no control over costs or the price of labor, equipment or materials, or over the Contractor's method of pricing, and that the opinions of probable construction costs provided herein are to be made on the basis of the Engineer's qualifications and experience. The Engineer makes no warranty, expressed or implied, as to the accuracy of such opinions as compared to bid or actual costs.
- (2) This opinion of costs DOES NOT include costs for the following items:
 - b. Undergrounding or relocation of overhead facilities; off-site dry utility improvements.
 - c. Engineering, surveying, construction management and soils testing.
 - d. Permits or city fees.
 - e. Costs for financing, bonds, and easements.
 - f. Design Costs
 - g. Traffic Control
 - f. Offsite improvements including fencing, etc.
- (4) Unit costs are 2022 basis and assume the project is constructed in one single phase.