

A TENANT IMPROVEMENT FOR: YOLO 911 DISPATCH CENTER 35 N. COTTONWOOD ST. WOODLAND, CA 95695



PROFESSIONAL STAMP:



CONSULTANT INFO:

GENERAL NOTES	FIRE EXTINGUISHER NOTES:	PROJECT INFORMATION	INDEX
<ol style="list-style-type: none"> 1. ALL WORK SHALL CONFORM TO ALL REQUIREMENTS OF THE STATE OF CALIFORNIA TITLE 24 REGARDLESS OF THE INFORMATION INDICATED ON THESE PLANS. 2. GENERAL CONTRACTOR SHALL FIELD VERIFY ALL EXISTING CONDITIONS PRIOR TO CONSTRUCTION. 3. A SEPARATE PLAN CHECK SUBMITTAL & PERMIT IS REQUIRED FOR THE FIRE ALARM SYSTEM & MUST BE SUBMITTED TO THE FIRE INSPECTOR/PLAN CHECKER IN THE LOCAL FIRE DEPARTMENT FOR APPROVAL & PERMIT PRIOR TO INSTALLATION. 4. A SEPARATE PLAN CHECK SUBMITTAL & PERMIT IS REQUIRED FOR THE AUTOMATIC FIRE SPRINKLER SYSTEM. PLANS & CALCS SHALL BE SUBMITTED TO THE FIRE INSPECTOR/PLAN CHECKER FOR APPROVAL & PERMIT PRIOR TO INSTALLATION. 5. A SEPARATE SIGN PERMIT & BUILDING PERMIT ARE REQUIRED FOR SIGNAGE. CONTRACTOR TO VERIFY ALL EXISTING CONDITIONS & DIMENSIONS @ THE JOB SITE BEFORE PROCEEDING W/ THE WORK. 6. SMOKE DETECTORS SHALL BE PROVIDED AS REQUIRED BY FIRE DEPARTMENT FIELD INSPECTORS. 7. AT TIME OF PERMIT ISSUANCE, CONTRACTOR SHALL SHOW A VALID WORKER'S COMPENSATION INSURANCE CERTIFICATE. 8. BUILDING TO BE FULLY SPRINKLERED PER N.F.P.A. 13 & OTHER NATIONALLY RECOGNIZED STANDARDS. 9. ENLARGED PLANS: WHERE ENLARGED OR PARTIAL PLANS ARE REFERENCED, DIMENSIONS & SPECIAL DETAILING OR FINISH REQUIREMENTS ARE NOTED ON THE ENLARGED PLANS AND USUALLY OMITTED ON THE SMALLER SCALE PLANS. 10. THE CONTRACTOR SHALL CAREFULLY STUDY & COMPARE THE CONTRACT DOCUMENTS PRIOR TO CONSTRUCTION, & SHALL REPORT TO THE ARCHITECT ANY ERROR, INCONSISTENCY, OR OMISSION HE MAY DISCOVER. 11. NO DEVIATION FROM CONTRACT DRAWINGS OR SPECIFICATIONS SHALL BE MADE WITHOUT WRITTEN APPROVAL FROM THE ARCHITECT. 12. ALL PARTITION DIMENSIONS ARE TO CENTERLINE OF STUD UNLESS NOTED OTHERWISE. ALL EXTERIOR DIMENSIONS ARE TO FACE OF CONCRETE UNLESS NOTED OTHERWISE. FACE OF CONCRETE ALIGNS W/ CONCRETE UNO. 13. ALL WALLS HAVING PLUMBING ARE TO BE SIZED TO ACCOMMODATE THE PLUMBING. 14. THE STRUCTURAL, MECHANICAL, & ELECTRICAL DRAWINGS ARE SUPPLEMENTARY TO THE ARCHITECTURAL DRAWINGS. SHOULD THERE BE A DISCREPANCY BETWEEN THE ARCHITECTURAL DRAWINGS & THE ENGINEERING DRAWINGS, SUCH A DISCREPANCY IS TO BE BROUGHT TO THE ATTENTION OF THE ARCHITECT PRIOR TO INSTALLATION OF SAID WORK. ANY WORK INSTALLED IN CONFLICT W/ THE ARCHITECTURAL DRAWINGS SHALL BE CORRECTED BY THE CONTRACTOR @ HIS OWN EXPENSE, & @ NO EXPENSE TO THE OWNER OR ARCHITECT. 15. THE CONTRACTOR SHALL BE RESPONSIBLE FOR VERIFICATION & COORDINATION W/ OTHER TRADES & THEIR WORK TO ENSURE COMPLIANCE W/ THE DRAWINGS & SPECIFICATIONS. ALSO HE SHALL VERIFY SIZES & LOCATIONS OF ALL OPENINGS FOR MECHANICAL, ELECTRICAL, & PLUMBING EQUIPMENT W/ ARCHITECT, BEFORE PROCEEDING W/ THE WORK. 16. IT SHALL BE THE RESPONSIBILITY OF THE CONTRACTOR TO SUPERVISE ALL CUTTING & PATCHING OF EXISTING FINISHED WORK INSTALLED IF SUCH WORK IS MADE NECESSARY BY NEW WORK ERRORS, CHANGES, OR OTHER REASONS. ALL REPLACEMENT WORK SHALL MATCH ADJOINING SURFACES. 17. DO NOT SCALE DRAWINGS. CONTRACTOR SHALL VERIFY ALL CONDITIONS & DIMENSIONS @ JOB SITE & IF ANY DISCREPANCIES ARE FOUND, THE ARCHITECT SHALL BE NOTIFIED. 18. PROVIDE GALVANIC ISOLATION OR OTHER MEANS OF ISOLATION BETWEEN DISSIMILAR METALS. 19. WHERE DOORS ARE LOCATED NEXT TO A WALL, THERE SHALL BE 4" MINIMUM CLEARANCE BETWEEN WALL SURFACE & FACE OF DOOR IN 90 DEGREES OPEN POSITION, UNLESS DETAILED OR DIMENSIONED OTHERWISE. 20. SOUND TRANSMISSION CONTROL SHALL CONFORM TO STATE LAWS. 21. ABBREVIATIONS THROUGHOUT THE PLANS ARE THOSE IN COMMON USE. ARCHITECT WILL DEFINE INTENT OF ANY IN QUESTION. 22. ALL SHOP FABRICATED ITEMS SHALL NOT BE FABRICATED FROM ANY DIMENSIONS OTHER THAN ACTUAL EXISTING FIELD DIMENSIONS. 23. PENETRATIONS OF PIPES, CONDUITS, ETC. IN WALLS OR FLOORS REQUIRING PROTECTED OPENINGS SHALL BE FIRE STOPPED. FIRE STOP MATERIAL SHALL BE A TESTED ASSEMBLY APPROVED BY THE LOCAL FIRE MARSHALL. 24. SUPPORT & BRACING OF ALL PIPES, DUCTS & CONDUITS PER LOCAL CODES. 25. CONTRACTOR SHALL PROVIDE & INSTALL ALL STIFFENERS, BRACING, BACKING PLATES, & SUPPORTING BRACKETS REQUIRED FOR THE INSTALLATION OF ALL CASEWORK AND OF ALL FLOOR MOUNTED OR SUSPENDED MECHANICAL, ELECTRICAL, OR EQUIPMENT. CONTRACTOR SHALL SUBMIT SHOP DRAWINGS & ENGINEERING CALCULATIONS AS REQUIRED TO THE ARCHITECT & STRUCTURAL ENGINEER FOR APPROVAL PRIOR TO FABRICATION & INSTALLATION. 	<ol style="list-style-type: none"> 1. THE MAXIMUM TRAVEL DISTANCE TO A PORTABLE FIRE EXTINGUISHER SHALL NOT EXCEED 75 FT; OR ONE EXTINGUISHER FOR EVERY 3,000 S.F. OF SPACE, WHICHEVER IS MORE RESTRICTIVE. 2. FIRE EXTINGUISHER CABINETS SHALL NOT BE LOCKED. 3. PORTABLE FIRE EXTINGUISHERS SHALL HAVE A SERVICE TAG, & INTERNAL MAINTENANCE TAG AFFIXED FROM A CALIFORNIA STATE FIRE MARSHAL PRIOR TO FINAL OCCUPANCY APPROVAL BY THE FIRE DEPT. 4. FIRE EXTINGUISHERS SHALL BE SERVICED ON AN ANNUAL BASIS IN ACCORDANCE W/ CALIFORNIA CODE OF REGULATIONS, TITLE 19. 5. A SIGN, W/ MINIMUM HEIGHT OF 8'-0", SHALL BE INSTALLED DIRECTLY ABOVE FIRE EXTINGUISHER LOCATIONS WHEN REQUIRED BY THE FIRE DEPT. THIS SIGN SHALL STATE 'FIRE EXTINGUISHER' & BE CLEARLY LEGIBLE & CONTRASTING W/ ITS BACKGROUND. 6. THE MINIMUM CLASSIFICATION FOR THE FIRE EXTINGUISHER(S) SHALL BE TYPE 2A10BC. 	<p>BUILDING DATA:</p> <p>APN: 064-010-032 STREET ADDRESS: 35 N. COTTONWOOD STREET JURISDICTION: CITY OF WOODLAND OCCUPANCY: B TYPE OF CONSTRUCTION: V-B STORIES: ONE SITE FIRE PROTECTION: WET SYSTEMS HYDRANTS FIRE PROTECTION: CENTRALLY MONITORED FULLY SPRINKLERED BUILDING</p> <p>TOTAL BUILDING S.F.: 7,438 S.F. PROJECT AREA: 1,404 S.F.</p> <p>CODES: 2022 CALIFORNIA BUILDING CODE 2022 CALIFORNIA MECHANICAL CODE 2022 CALIFORNIA ELECTRICAL CODE 2022 CALIFORNIA ENERGY CODE</p>	<p>ARCHITECTURAL</p> <p>A0.0 COVER SHEET A1.0 SITE PLAN (FOR REFERENCE ONLY) A1.1 SITE DETAILS (FOR REFERENCE ONLY) A2.0 EGRESS PLAN A2.1 OVERALL FLOOR PLAN A2.2 DEMO FLOOR PLAN AND REFLECTED CEILING PLAN A2.3 NEW FLOOR PLAN AND REFLECTED CEILING PLAN A2.4 ENLARGED RESTROOMS AND DETAILS A3.1 DOOR SCHEDULE A4.1 WALL TYPE AND CEILING DETAILS</p> <p>MECHANICAL</p> <p>MO MECHANICAL SCHEDULES, DETAILS, & GENERAL NOTES M1 MECHANICAL PLAN</p> <p>ELECTRICAL</p> <p>E0 ELECTRICAL SCHEDULES, ONE-LINE, & GENERAL NOTES E1 ELECTRICAL PLAN E2 INDOOR LIGHTING ENERGY COMPLIANCE</p>
	SEPARATE PERMITS & DEFERRED SUBMITTALS	PROJECT SCOPE	VICINITY MAP
	<p>SEPARATE PERMITS:</p> <ol style="list-style-type: none"> 1. FIRE ALARM / FIRE SPRINKLER 	<p>THIS PROJECT IS A TENANT IMPROVEMENT IN AN EXISTING OFFICE BUILDING. THE EXISTING DISPATCH ROOM IS BEING SLIGHTLY EXPANDED & MODERNIZED, INCLUDING MECHANICAL & ELECTRICAL RE-CONFIGURATION ALONG W/ (N) SYSTEMS FURNITURE.</p>	
		PROJECT COORDINATION	
		<p>ARCHITECT PERKINS, WILLIAMS & COTTERILL, INC. 3320 DATA DRIVE, SUITE 200 RANCHO CORDOVA, CALIFORNIA 95670 (916) 851-1400</p> <p>MECHANICAL/PLUMBING/ELECTRICAL OPTIMIZED ENERGY AND FACILITIES CONSULTING, INC. 5734 LONETREE BOULEVARD ROCKLIN, CALIFORNIA 95765 (916) 626-5518</p>	<p style="text-align: center;">NORTH </p>

A TENANT IMPROVEMENT FOR:
**YOLO 911
 DISPATCH CENTER
 35 N. COTTONWOOD ST.
 WOODLAND, CA 95695**

ISSUE TYPE:

REVISIONS:

DATE: 12-21-23

PROJECT NUMBER: 23-378

DRAWING TITLE: COVER SHEET

SHEET NUMBER: A0.0

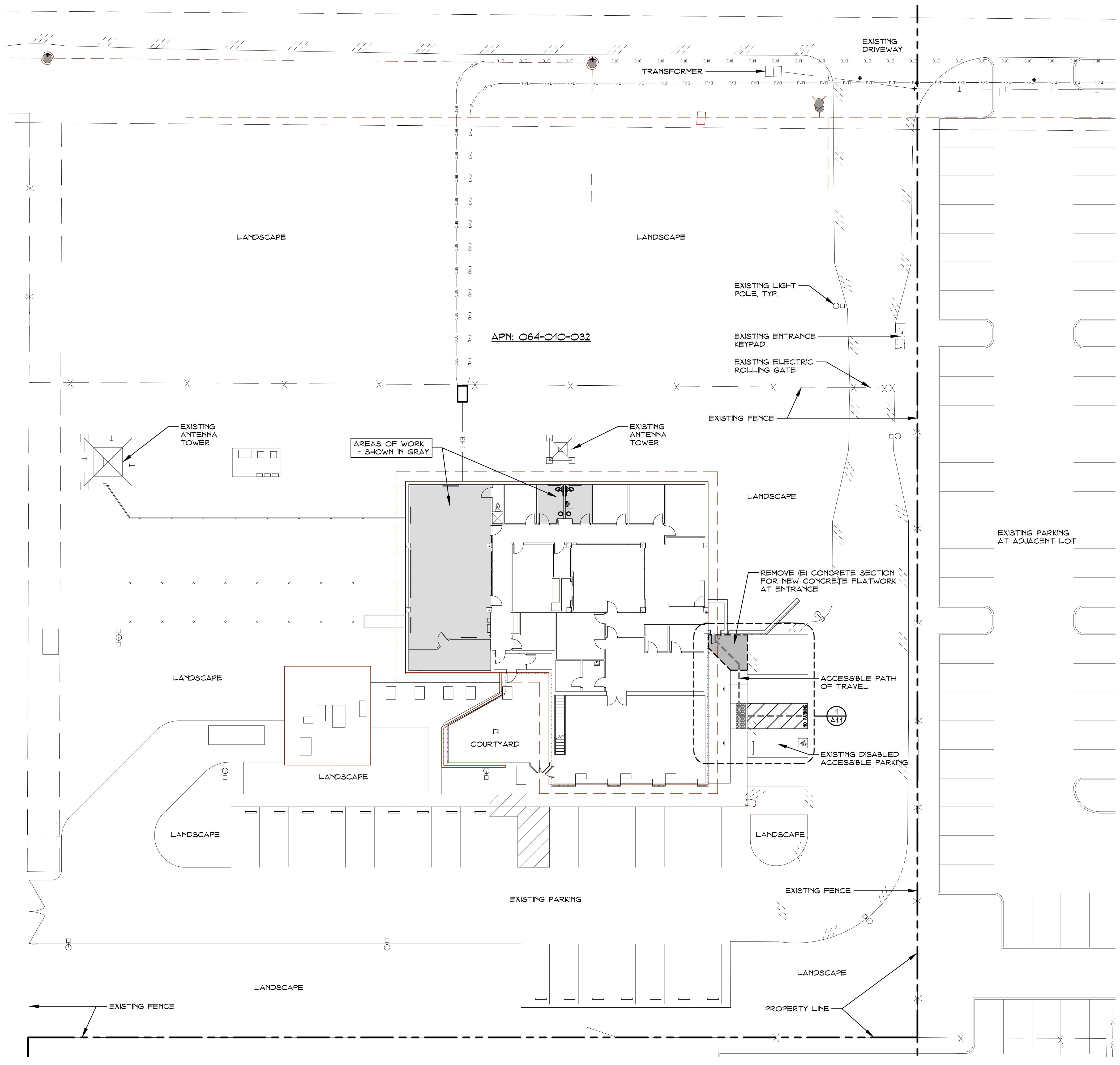

2 SITE PLAN
SCALE: 1/16" = 1'-0"

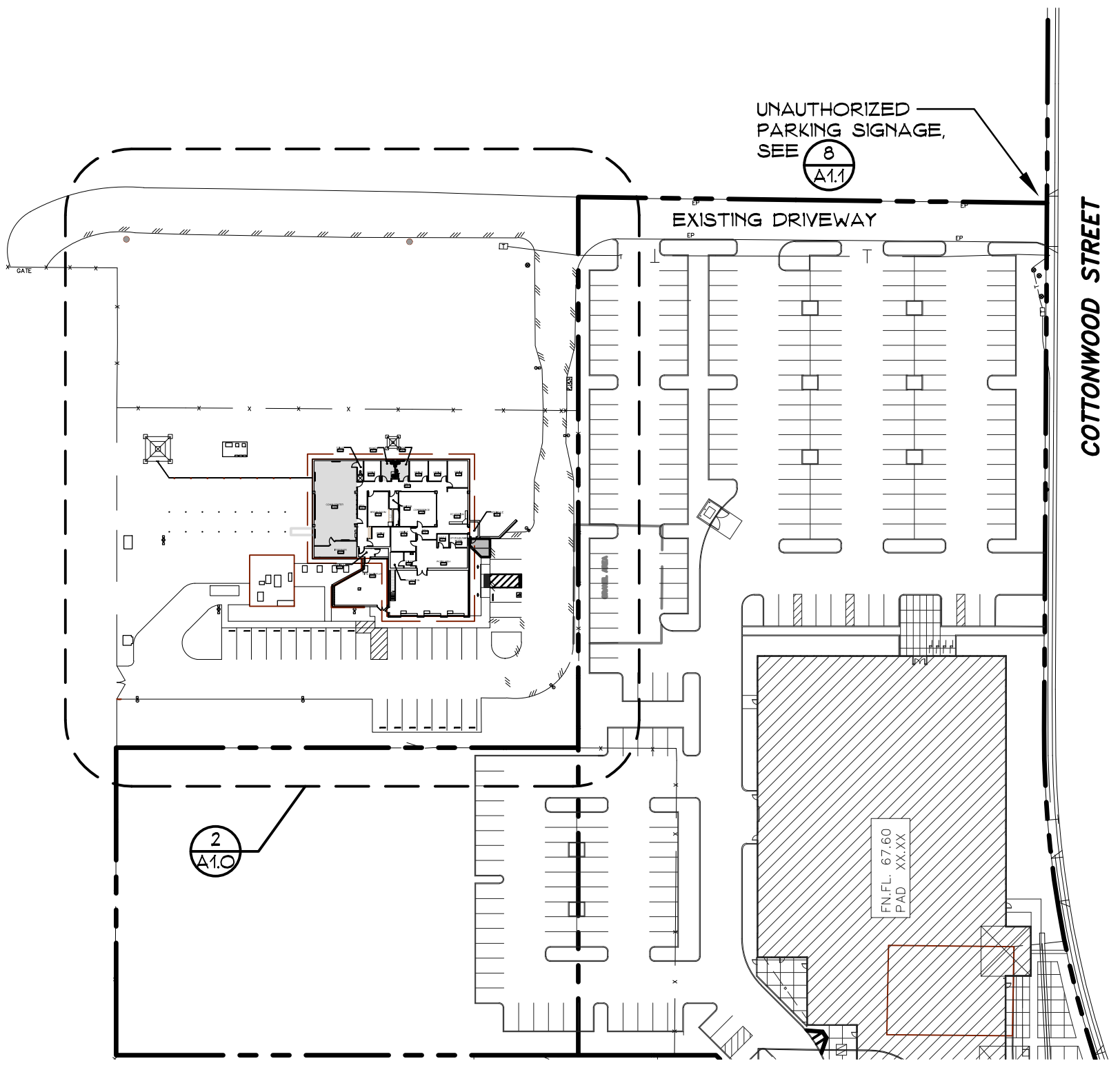

1 OVERALL SITE PLAN - FOR REFERENCE
SCALE: 1" = 80'-0"

ACCESSIBILITY NOTES:

PROVIDE SIGNAGE DIRECTING PERSONS W/ DISABILITIES TO THE ACCESSIBLE ROUTE OF TRAVEL. SIGN SHALL BE LOCATED AT EVERY MAJOR JUNCTION ALONG OR LEADING TO AN ACCESSIBLE ROUTE OF TRAVEL. THERE SHALL BE A SIGN DISPLAYING THE INTERNATIONAL SYMBOL OF ACCESSIBILITY. SIGN SHALL INDICATE THE DIRECTION TO THE ACCESSIBLE FACILITIES & BUILDING ENTRANCES. SIGNAGE SHALL COMPLY W/ THE REQUIREMENTS FOUND IN SECTION 11B-502.8

WALKWAYS AND SIDEWALKS ALONG ACCESSIBLE ROUTES OF TRAVEL:

- A. SHALL BE CONTINUOUSLY ACCESSIBLE
- B. SHALL HAVE MAXIMUM 1/2" CHANGE IN ELEVATION
- C. SHALL BE MINIMUM 48" IN WIDTH
- D. SHALL HAVE A MAX. CROSS SLOPE OF 1/4" : 1'
- E. SHALL HAVE RAMP COMPLIING WITH CBC 11B-405 & 11B-406, WHERE NECESSARY TO CHANGE ELEVATION AT A SLOPE EXCEEDING 5% (1E, 1:20)

PROVIDE INTERNATIONAL SYMBOL OF ACCESSIBILITY ON OR ADJACENT TO ENTRANCE LOCATED ON STRIKE SIDE & MOUNTED 60" A.F.F. TO THE CENTER OF THE SIGN, PER SECTION 11B-216.6. SEE 2/A2.0.

WALKWAYS AT PRIMARY ENTRY/EXITS SHALL BE LEVEL WITH BUILDING FINISH FLOOR WITH 2% MAX. CROSS SLOPE FOR 5'-0" (MIN) IN WIDTH WITH AT LEAST 24" CLEAR WIDTH PROVIDED FROM STRIKE EDGE OF DOOR. SEE 5/A1.1.

■■■■■ ACCESSIBLE PATH OF TRAVEL

PERKINS, WILLIAMS & COTTELL, INC.
ARCHITECTS
3329 Data Drive, Suite 200 - Rancho Cordova, California 95670
T: (916) 851-1400 F: (916) 851-1408 E: pwcarch@pwcarchitects.com



PROFESSIONAL STAMP
CONSULTANT INFO:

A TENANT IMPROVEMENT FOR:
**YOLO 911
DISPATCH CENTER**
35 N. COTTONWOOD ST.
WOODLAND, CA 95695

ISSUE TYPE:

REVISIONS:

DATE: 12-21-23
PROJECT NUMBER: 23-378
DRAWING TITLE: SITE PLAN (FOR REFERENCE ONLY)
SHEET NUMBER:

A1.0

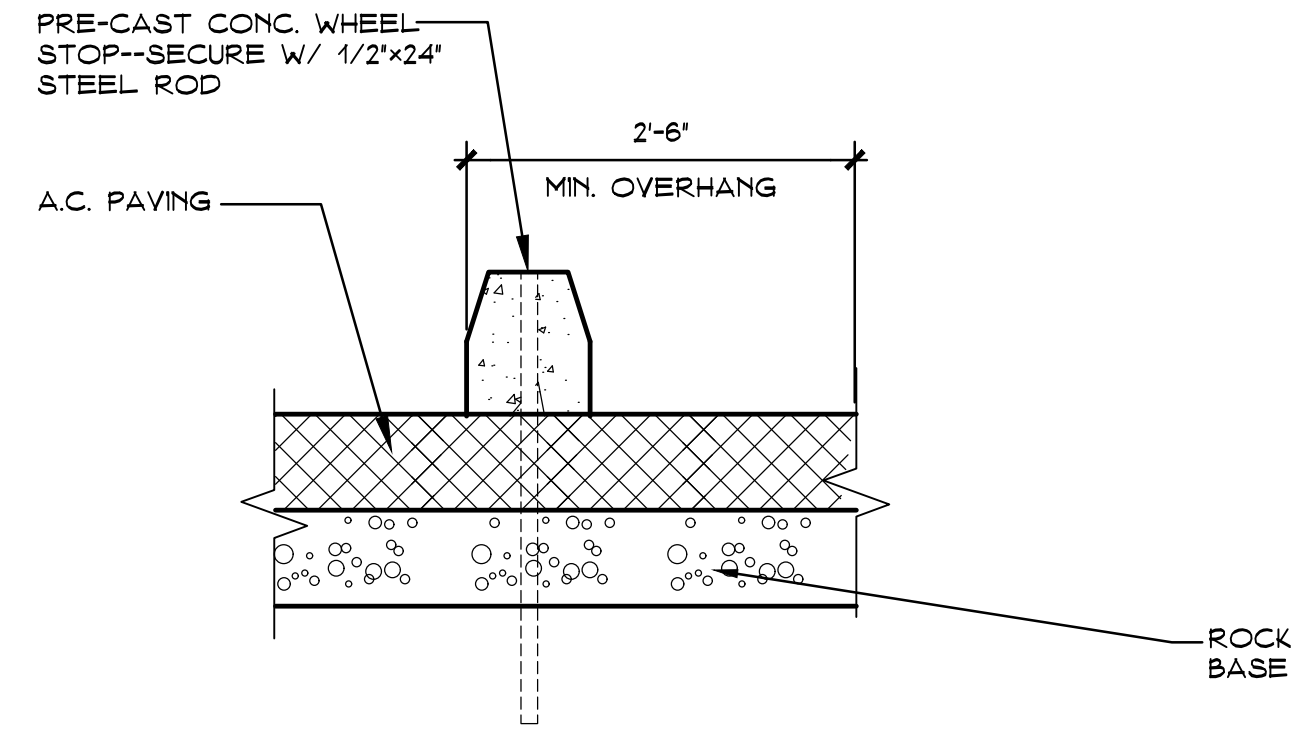

6 WHEEL STOP
SCALE: 1/2" = 1'-0"

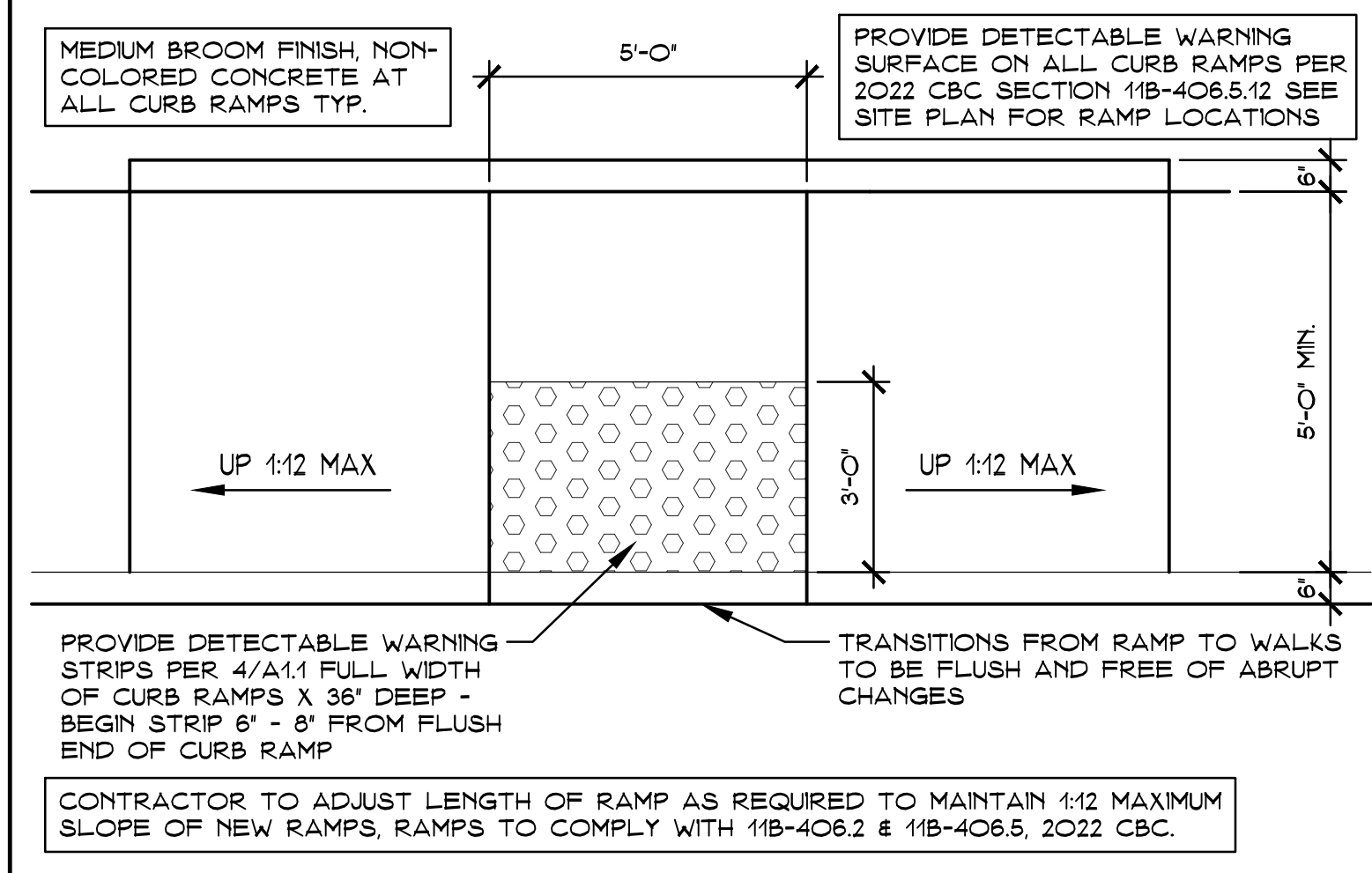

3 TYPICAL PARALLEL RAMP
SCALE: 3/8" = 1'-0"

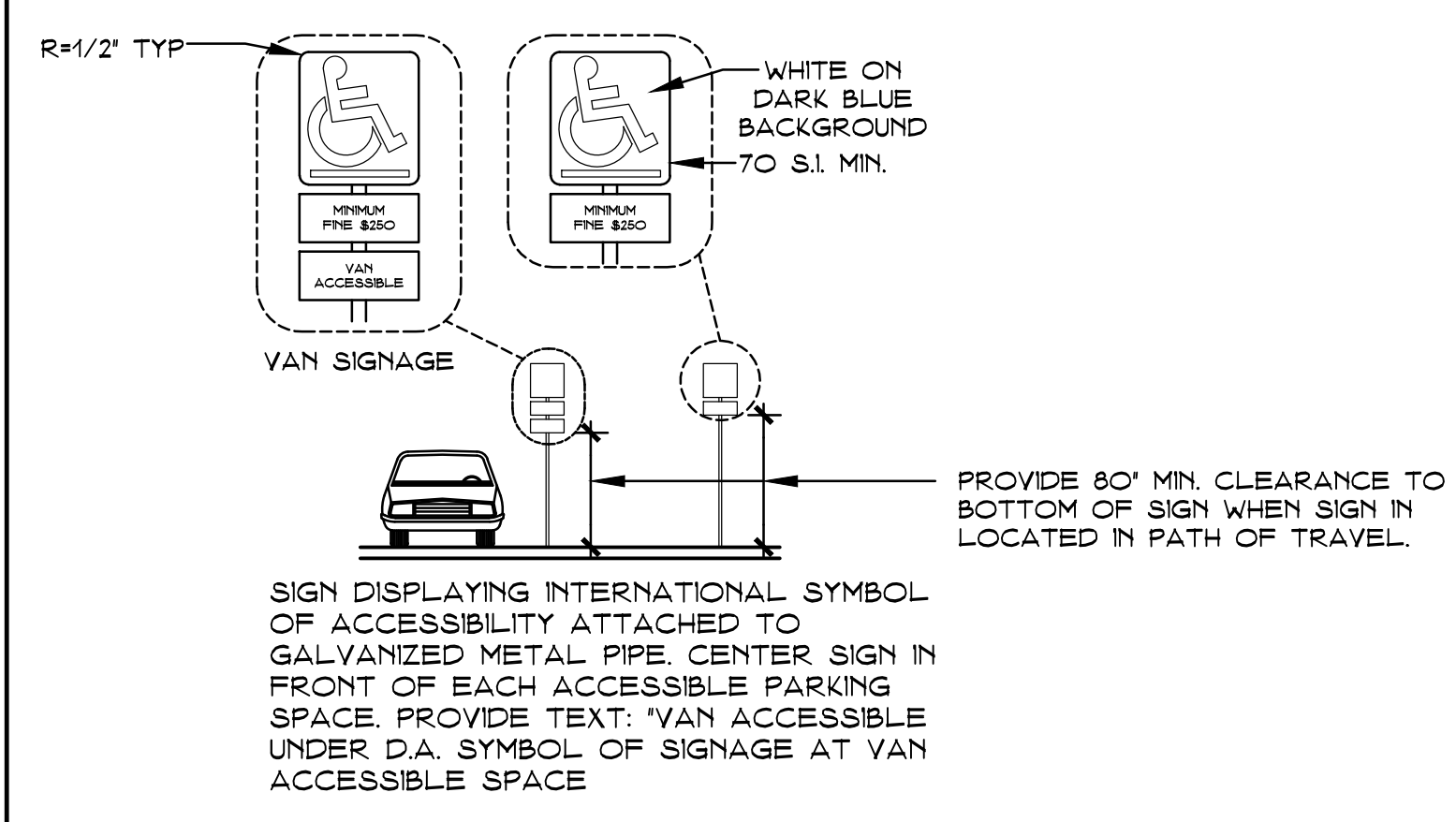

7 ACCESSIBLE PARKING STALL SIGNAGE
NO SCALE

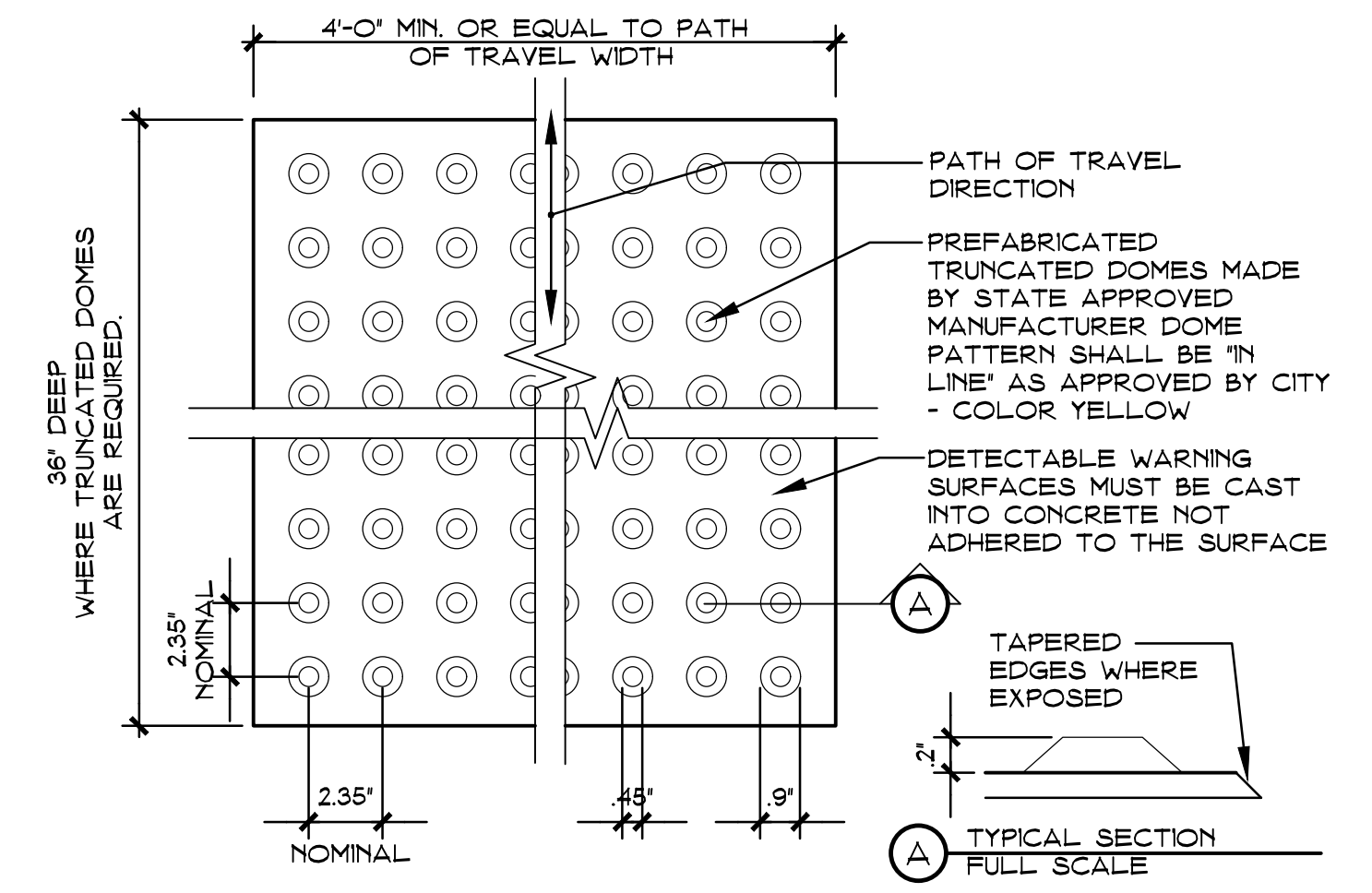

4 DETECTABLE WARNING STRIP
SCALE: 3" = 1'-0"

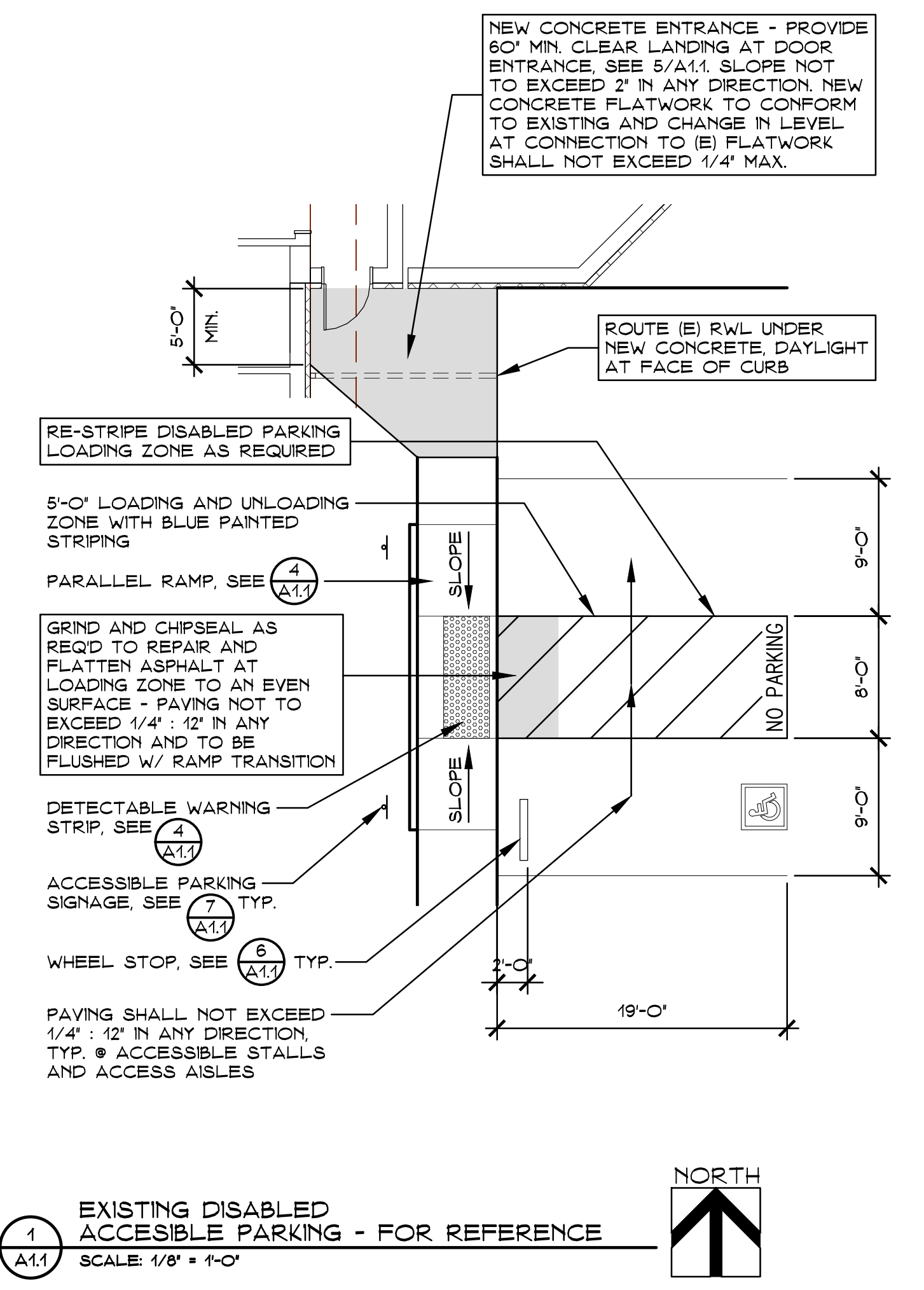

1 EXISTING DISABLED ACCESSIBLE PARKING - FOR REFERENCE
SCALE: 1/8" = 1'-0"

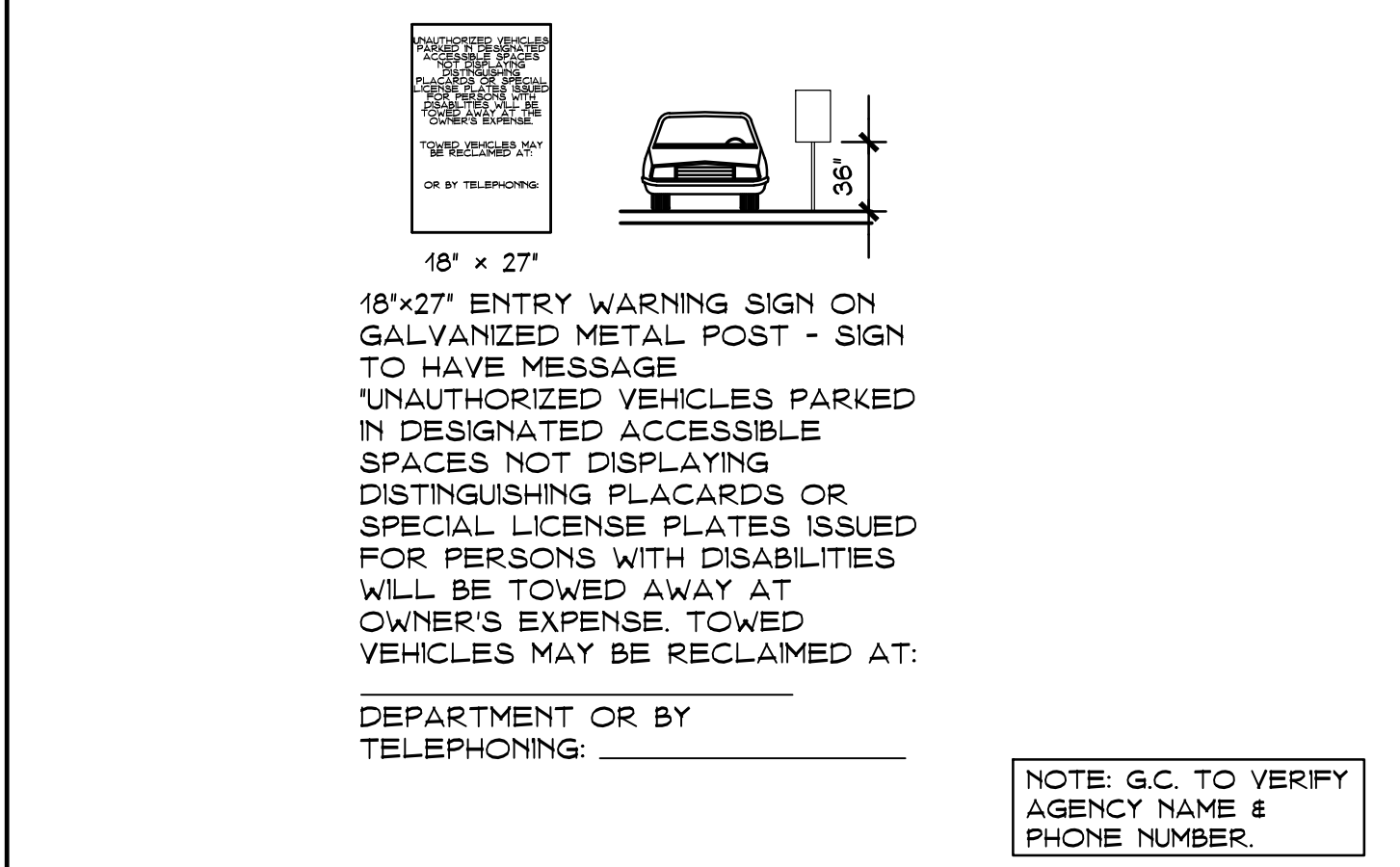

8 UNAUTHORIZED PARKING SIGNS AT ENTRIES
SCALE: 1/8" = 1'-0"

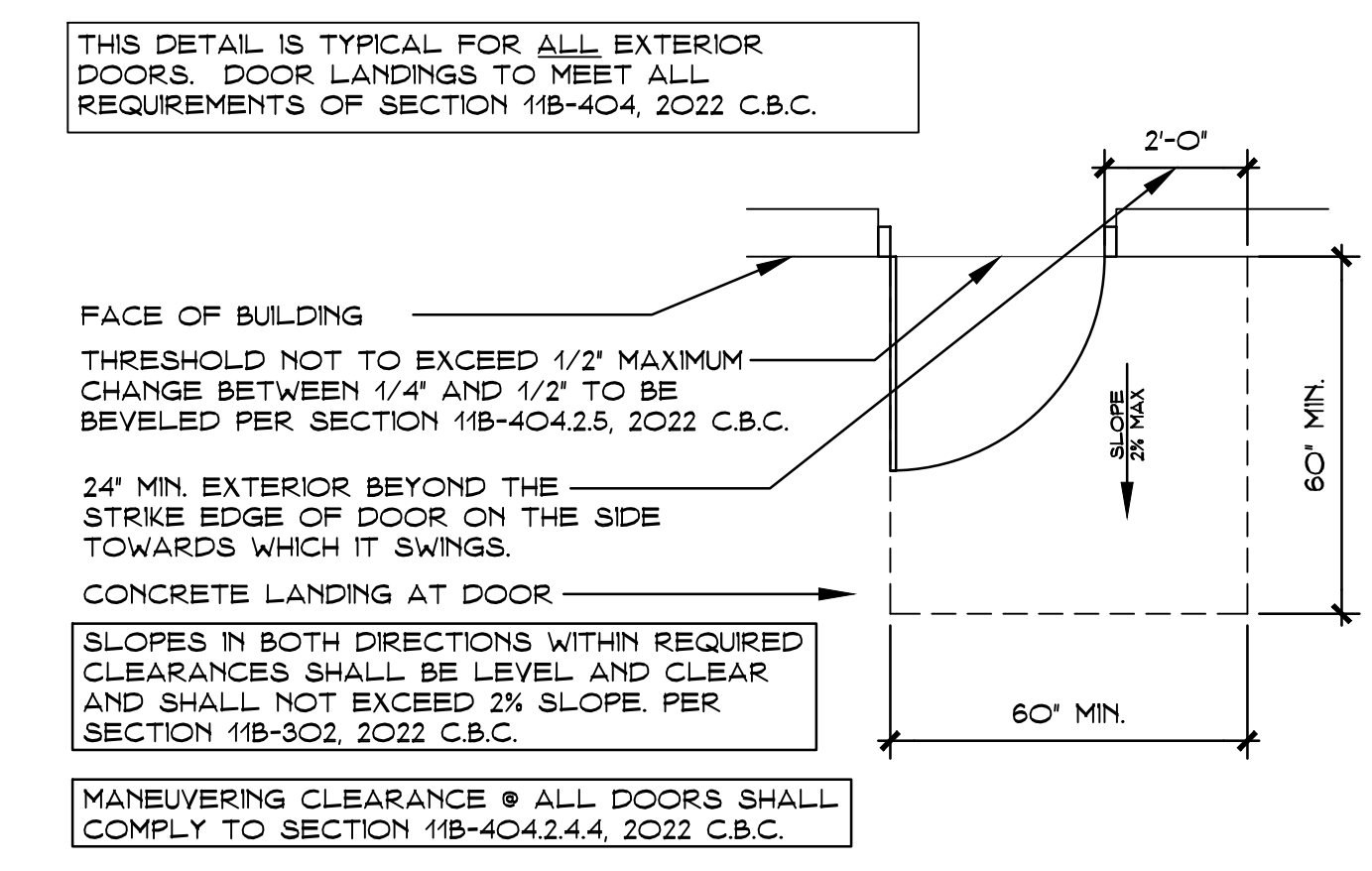

5 TYP. DOOR LANDINGS
SCALE: 3/8" = 1'-0"

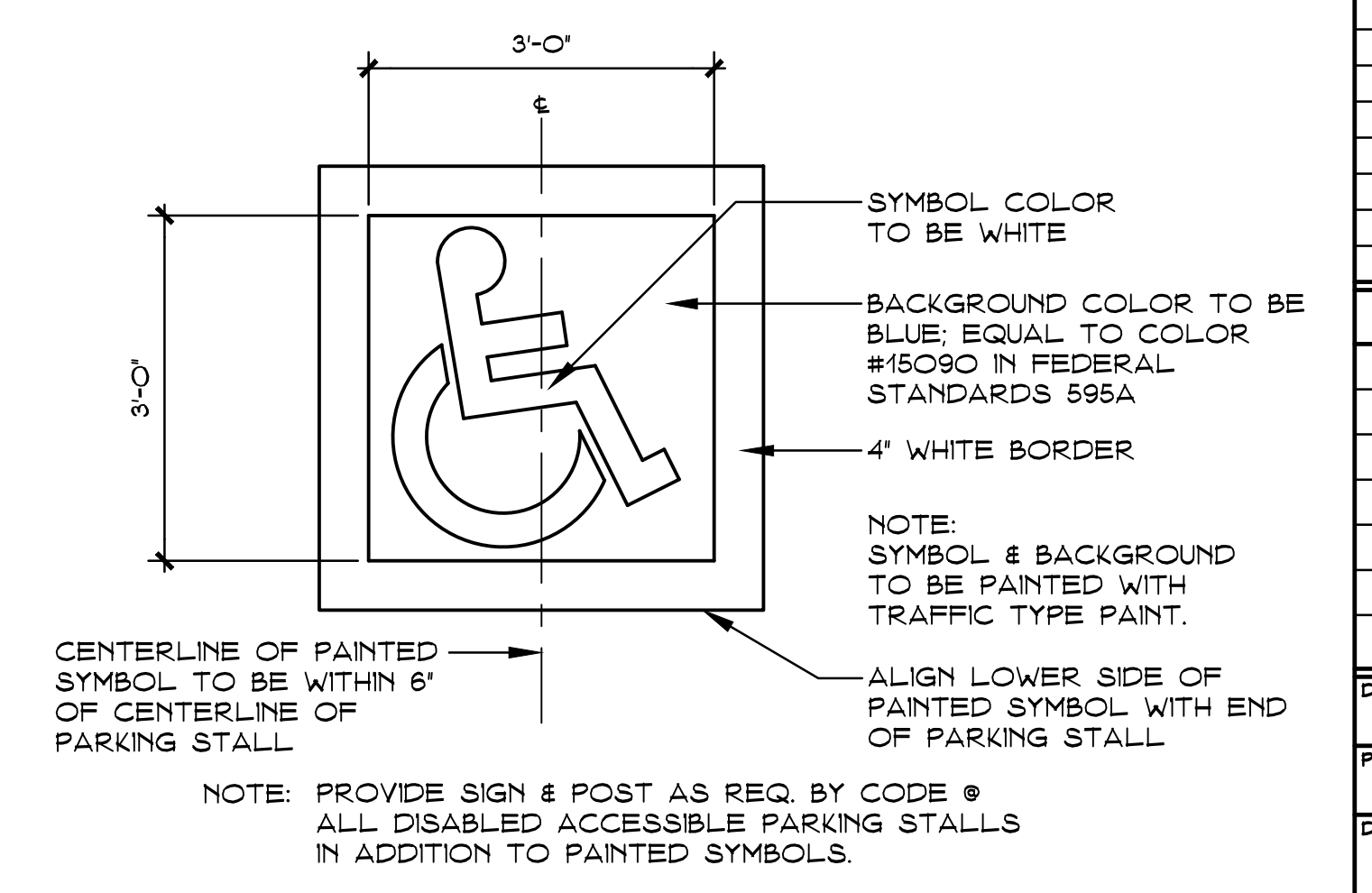

2 DISABLED ACCESSIBLE SYMBOL
SCALE: 3/8" = 1'-0"

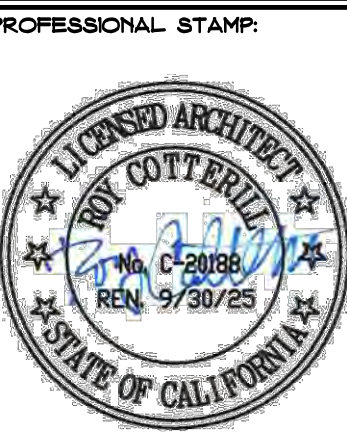

CONSULTANT INFO:

A TENANT IMPROVEMENT FOR:
YOLO 911 DISPATCH CENTER
35 N. COTTONWOOD ST.
WOODLAND, CA 95695

ISSUE TYPE:

REVISIONS:

DATE: 12-21-23
PROJECT NUMBER: 23-378
DRAWING TITLE: SITE DETAILS (FOR REFERENCE ONLY)
SHEET NUMBER:

A1.1

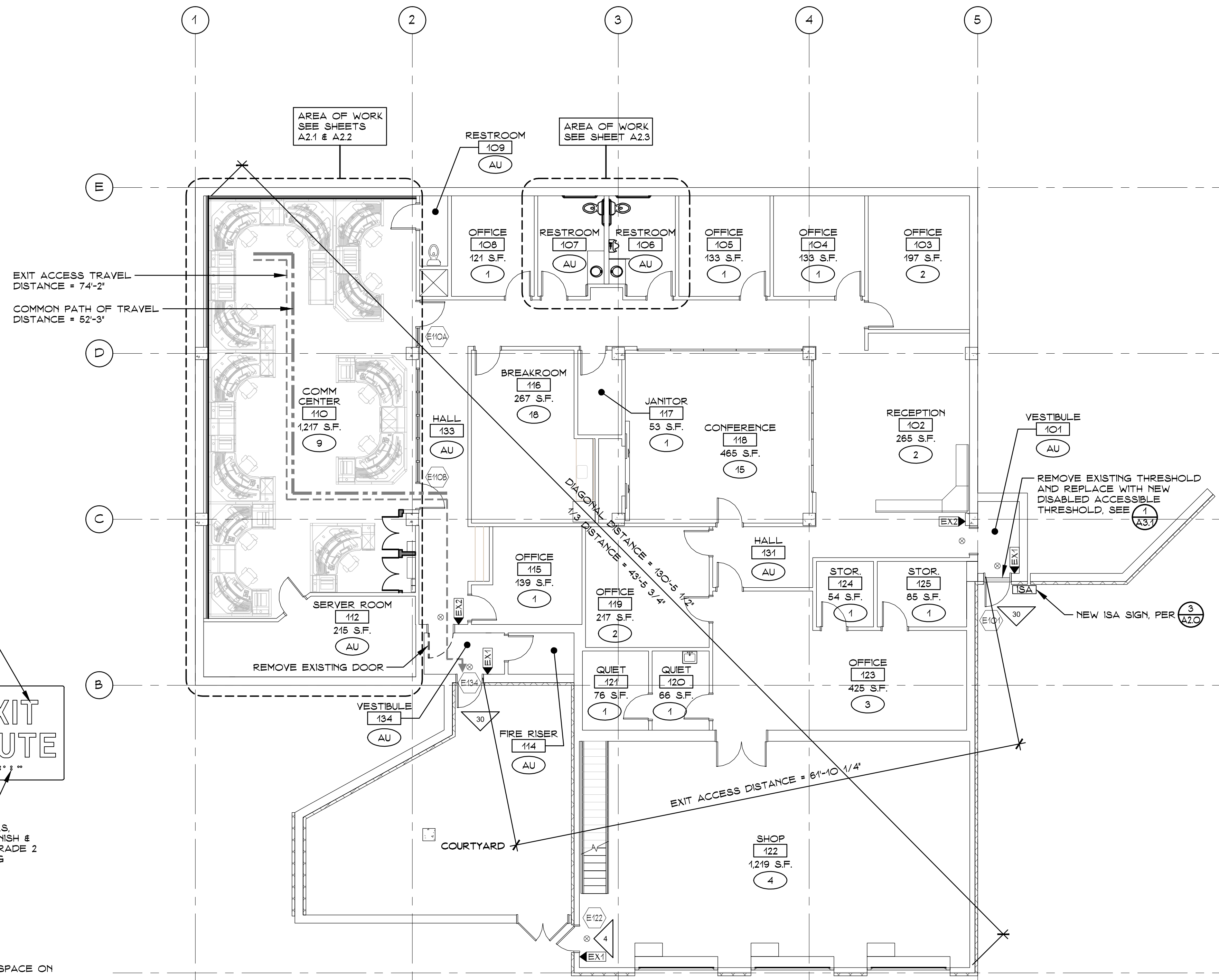

LEGEND

- (E) WALL, TYP.
- # OCCUPANT LOAD
- AU ACCESSORY USE - NO OCCUPANT LOAD
- # TOTAL ACCUMULATED OCCUPANT LOAD THROUGH DOORWAY
- ⊗ EXIT SIGN
- ISA INTERNATIONAL SYMBOL OF ACCESSIBILITY ON OR ADJACENT TO ENTRANCES, LOCATED STRIKESIDE & MOUNTED 60" A.F.F. TO THE CENTER OF THE SIGN, PER SECTION 11B-216.6, 2022 C.B.C.
- > PROJECT EXIT ACCESS TRAVEL DISTANCE
- CONF. ROOM ROOM NAME
- OOO ROOM NUMBER
- ⊗ EXISTING DOOR SYMBOL, SEE A3.1

EGRESS WIDTH CALCULATION

DOOR WIDTH / O.2 = PERSONS ALLOWED THROUGH

- (3'-0" WIDE) 33' / O.2 = 165 PERSONS
- (4'-0" WIDE) 48' / O.2 = 225 PERSONS
- (6'-0" WIDE) 66' / O.2 = 330 PERSONS

EXITING

OCCUPANT LOAD FACTORS PER TABLE 1004.1.2

BUSINESS AREAS	150 GROSS
STORAGE	300 GROSS
CONFERENCE ROOM	15 NET
BREAK ROOM	15 NET
SHOP	300 GROSS

EXITING OCCUPANT LOAD ANALYSIS

AREA: 7,438 S.F.

TOTAL OCCUPANT LOAD: 64

TOTAL EXITS REQUIRED: 2 (TABLE 1006.3.1)

TOTAL EXITS PROVIDED: 3

TOTAL REQUIRED EXIT WIDTH: 3 x 64 = 192' (SEC. 1005.3, CBC 2022)

ACTUAL EXIT WIDTH: 99'

MAXIMUM TRAVEL DISTANCE TO EXITS: B = 300 FEET (TABLE 1017.2)

SIGN & IDENTIFICATION REQUIREMENTS

IDENTIFICATION SIGNS: WHEN SIGNS IDENTIFY PERMANENT ROOMS & SPACES OF THE BUILDING OR SITE, THEY SHALL COMPLY W/ SECTION 11B-216.2, 2022 C.B.C.

DIRECTIONAL & INFORMATIONAL SIGNS: WHEN SIGNS DIRECT TO OR GIVE INFORMATION ABOUT PERMANENT ROOMS & FUNCTIONAL SPACES OF THE BUILDING OR SITE, THEY SHALL COMPLY W/ SECTION 11B-216.3, 2022 C.B.C.

ACCESSIBILITY SIGNS: WHEN SIGNS IDENTIFY, DIRECT TO OR GIVE INFORMATION ABOUT ACCESSIBLE ELEMENTS & FEATURES OF THE BUILDING OR SITE, THEY SHALL INCLUDE THE APPROPRIATE SYMBOL OF ACCESSIBILITY & SHALL COMPLY W/ SECTION 11B-703.6.2 & 11B-703.7.2.1, 2022 C.B.C.

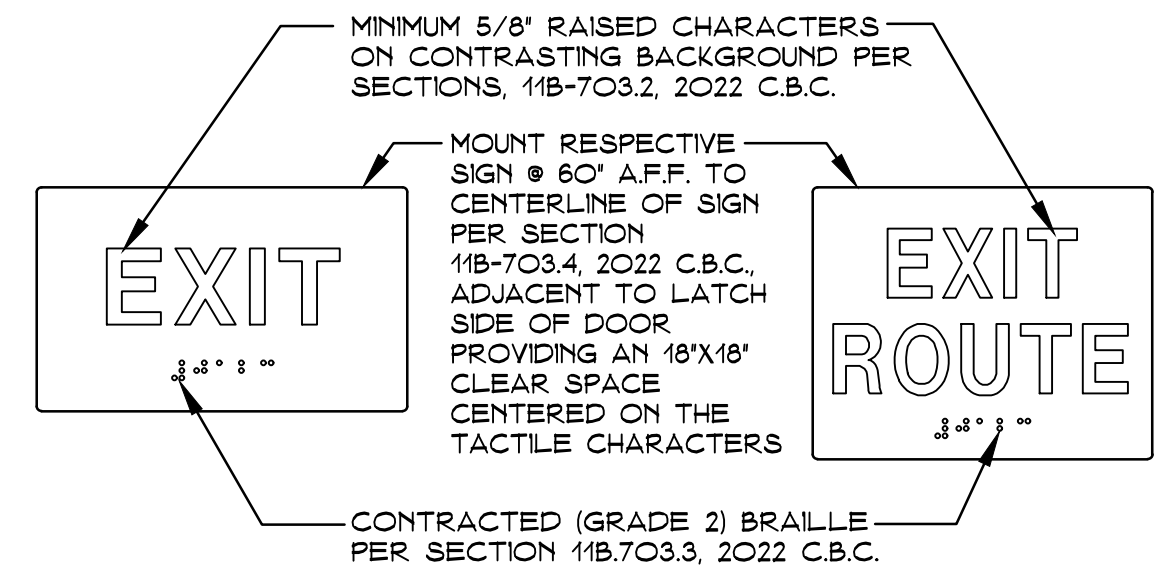

TACTILE EXIT SIGNS PER SECTION 1011.4, W/ CHARACTERS, SYMBOLS & THEIR BACKGROUND HAVING A NON-GLARE FINISH & CONTRASTING COLOR. SIGNS SHALL BE CONTRACTED GRADE 2 BRAILLE PER CBC SECTION 11B-703.3 W/ THE FOLLOWING WORDS, AS INDICATED: 'EXIT' & 'EXIT ROUTE'.

- EX1 = EXIT
- EX2 = EXIT ROUTE

MOUNTING LOCATION AND HEIGHT: TACTILE EXIT SIGNS SHALL BE LOCATED ON THE WALL ADJACENT TO THE LATCH, WHERE THERE IS NO WALL SPACE ON LATCH SIDE, SIGNS SHALL BE PLACED ON THE NEAREST ADJACENT WALL, PREFERABLE ON THE RIGHT. SIGNS WITH RAISED CHARACTERS AND BRAILLE SHALL BE LOCATED 48 INCHES MINIMUM ABOVE THE FINISH FLOOR OR GROUND SURFACE, MEASURED FROM THE BASELINE OF THE LOWEST LINE OF BRAILLE AND 60 INCHES MAXIMUM ABOVE THE FINISHED FLOOR OR GROUND SURFACE, MEASURED FROM THE BASELINE OF THE HIGHEST LINE OF RAISED CHARACTERS. MOUNTING LOCATION SHALL BE DETERMINED SO THAT A PERSON MAY APPROACH WITHIN 3 INCHES OF SIGNAGE WITHOUT ENCOUNTERING PROTRUDING OBJECTS OR STANDING WITHIN THE SWING OF A DOOR.

2 TACTILE EXIT SIGNAGE
A2.0 NO SCALE

1 EGRESS PLAN
SCALE: 1/8" = 1'-0"
NORTH

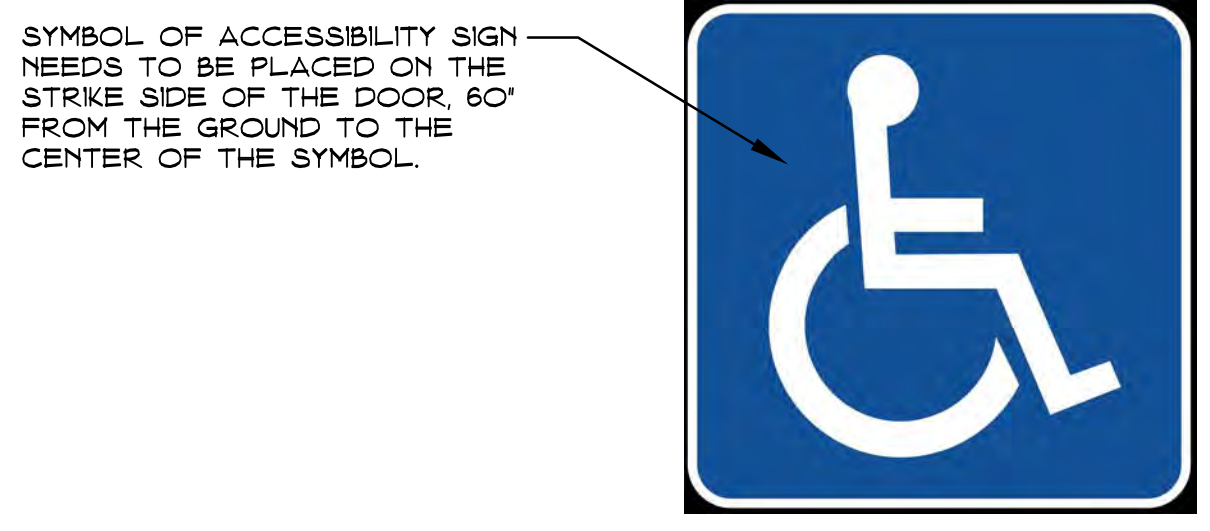

2 ISA SYMBOL
A2.0 NO SCALE

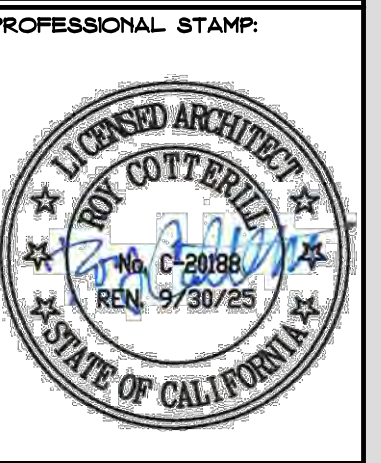

CONSULTANT INFO:

A TENANT IMPROVEMENT FOR:
**YOLO 911
DISPATCH CENTER**
35 N. COTTONWOOD ST.
WOODLAND, CA 95695

ISSUE TYPE:

REVISIONS:

DATE: 12-21-23
PROJECT NUMBER: 23-378
DRAWING TITLE: EGRESS PLAN
SHEET NUMBER:

A2.0

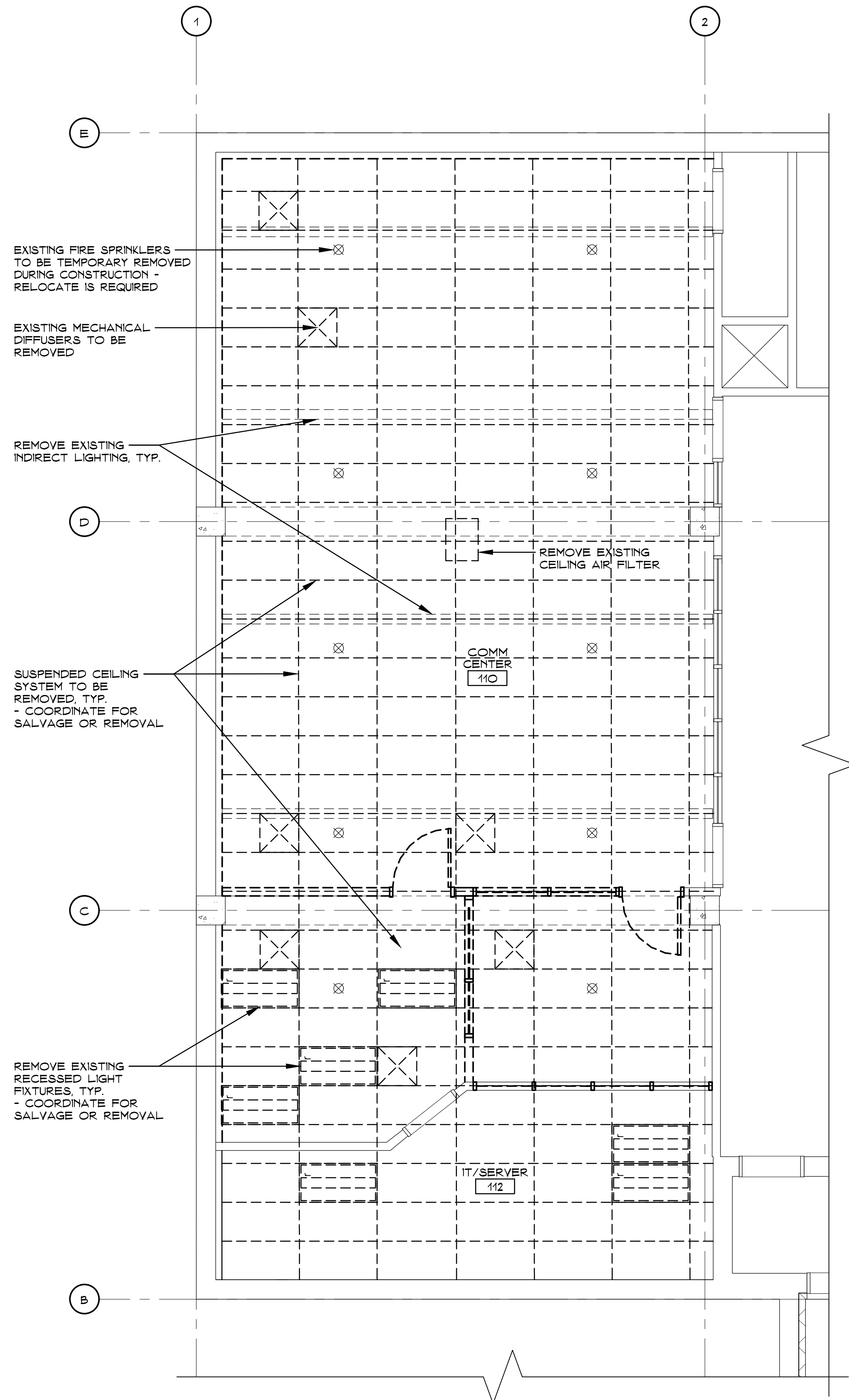

2 DEMO REFLECTED CEILING PLAN
 A2.1 SCALE: 1/4" = 1'-0"
 NORTH

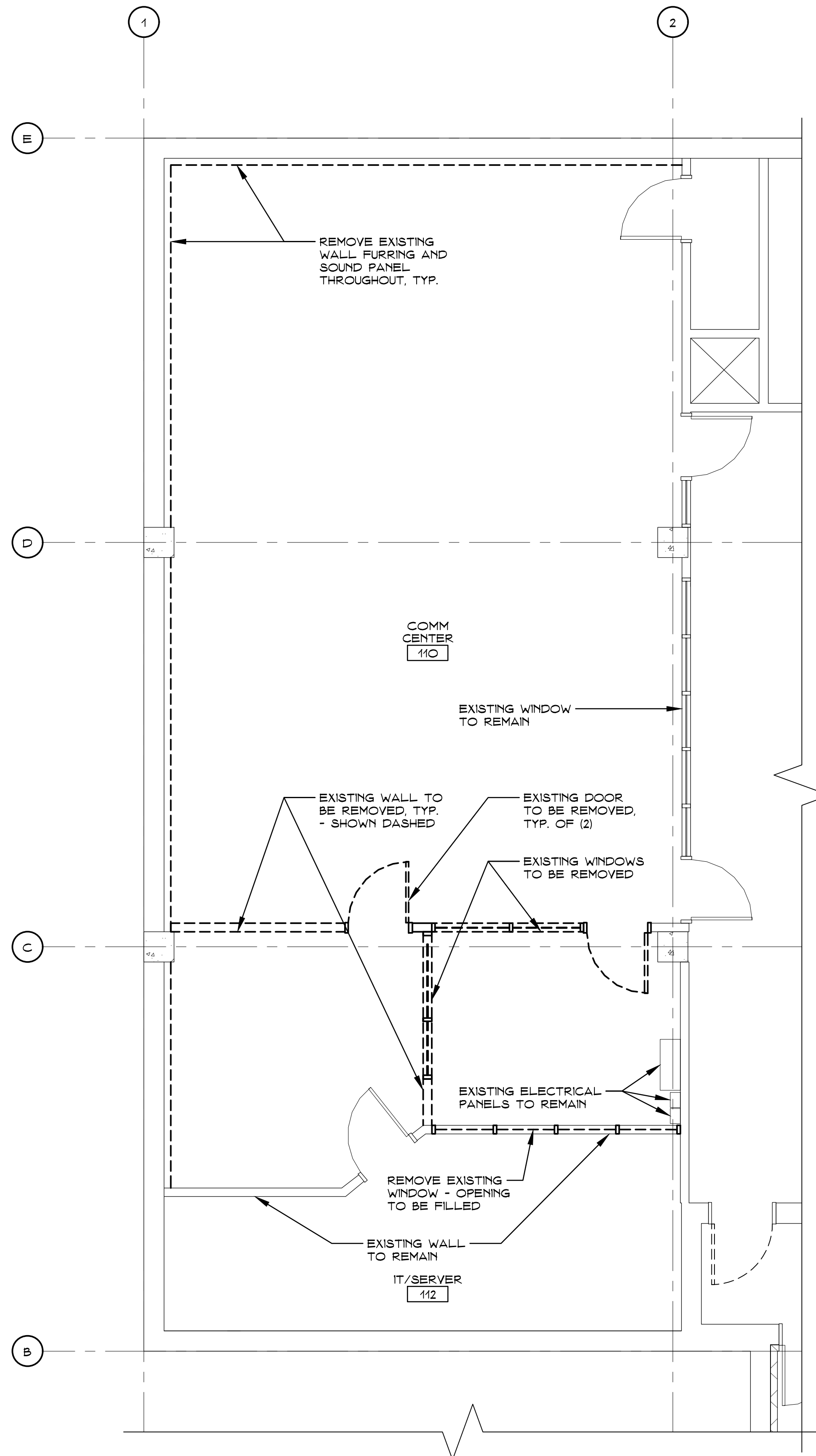

1 DEMO FLOOR PLAN
 A2.1 SCALE: 1/4" = 1'-0"
 NORTH

DEMO FLOOR PLAN LEGEND

- (E) WALL TO REMAIN
- (E) DOOR TO REMAIN
- (E) WINDOW TO REMAIN
- WALL TO BE DEMOLISHED
- - - DOOR TO BE REMOVED
- - - WINDOW TO BE REMOVED

DEMO REFLECTED CEILING PLAN LEGEND

- - - SUSPENDED CEILING SYSTEM TO BE REMOVED
- ☒ RECESSED LIGHT FIXTURE TO BE REMOVED
- ☒ MECHANICAL DIFFUSER TO BE REMOVED

CUTTING AND PATCHING NOTES

EXECUTION

- A. VERIFY THAT DEMOLITION IS COMPLETE AND AREAS ARE READY FOR INSTALLATION OF NEW WORK. CONTRACTOR TO EXAMINE EXISTING CONDITIONS PRIOR TO COMMENCING WORK.
- B. ASSESS CONDITIONS AFFECTING PERFORMANCE OF WORK. BEGINNING OF CUTTING OR PATCHING MEANS ACCEPTANCE OF EXISTING CONDITIONS.
- C. CUT, MOVE OR REMOVE ITEMS AS NECESSARY FOR ACCESS TO ALTERATIONS AND RENOVATION WORK. REPLACE AND RESTORE AT COMPLETION.
- D. REMOVE UNSUITABLE MATERIAL NOT MARKED FOR SALVAGE. REPLACE MATERIALS AS REQUIRED FOR FINISHED WORK.
- E. REMOVE DEBRIS AND ABANDONED ITEMS FROM AREA AND FROM CONCEALED SPACES.
- F. PREPARE SURFACE AND REMOVE SURFACE FINISHES TO PROVIDE FOR PROPER INSTALLATION OF NEW WORK AND FINISHES.
- G. COORDINATE WORK OF ALTERATIONS AND RENOVATIONS TO EXPEDITE COMPLETION AND TO ACCOMMODATE OWNER OCCUPANCY. PATCH AND EXTEND EXISTING WORK USING SKILLED MECHANICS WHO ARE CAPABLE OF MATCHING EXISTING QUALITY OF WORKMANSHIP.
- H. ROOM FINISHES. COMPLETE IN ALL RESPECTS INCLUDING OPERATIONAL MECHANICAL AND ELECTRICAL WORK.
- I. REMOVE, CUT AND PATCH WORK IN A MANNER TO MINIMIZE DAMAGE AND TO PROVIDE A MEANS OF RESTORING PRODUCTS AND FINISHES TO SPECIFIED CONDITION.
- J. REFINISH VISIBLE EXISTING SURFACES TO REMAIN IN RENOVATED ROOMS AND SPACES WITH A NEAT TRANSITION TO ADJACENT FINISHES.
- K. WHERE NEW WORK ABUTS OR ALIGNS WITH EXISTING, PERFORM A SMOOTH AND EVEN TRANSITION. PATCH WORK TO MATCH EXISTING ADJACENT WORK IN TEXTURE AND APPEARANCE, WITHOUT BREAKS, STEPS OR BULKHEADS.
- L. WHEN FINISHED SURFACES ARE CUT SO THAT A SMOOTH TRANSITION WITH NEW WORK IS NOT POSSIBLE, TERMINATE EXISTING SURFACE ALONG A STRAIGHT LINE AT A NATURAL LINE OF DIVISION AND MAKE RECOMMENDATION TO ARCHITECT.
- M. PATCH OR REPLACE PORTIONS OF EXISTING SURFACES THAT ARE DAMAGED BY NEW WORK.
- N. REPAIR SUBSTRATE PRIOR TO PATCHING FINISH.
- O. FINISH PATCHES TO PRODUCE UNIFORM FINISH AND TEXTURE OVER ENTIRE AREA. WHEN FINISH CANNOT BE MATCHED, REFINISH ENTIRE SURFACE TO NEAREST INTERSECTIONS.
- P. CLEAN ADJACENT OWNER OCCUPIED AREAS OF WORK SOILED BY WORK OF THIS CONTRACT.

ALTERATIONS, CUTTING AND PROTECTION

- A. ASSIGN THE WORK OF MOVING, REMOVAL, CUTTING AND PATCHING TO TRADES QUALIFIED TO PERFORM THE WORK IN A MANNER TO CAUSE LEAST DAMAGE TO EACH TYPE OF WORK AND PROVIDE MEANS OF RETURNING SURFACES TO APPEARANCE OF NEW WORK.
- B. PERFORM CUTTING AND REMOVAL WORK TO REMOVE MINIMUM NECESSARY AND IN A MANNER TO AVOID DAMAGE TO ADJACENT WORK. CUT FINISH SURFACES BY METHODS TO TERMINATE SURFACES IN A STRAIGHT LINE AT A NATURAL POINT OF DIVISION OR WHERE INDICATED.
- C. PROTECT EXISTING FINISHES, EQUIPMENT AND ADJACENT WORK THAT ARE SCHEDULED TO REMAIN. FROM DAMAGE. PROTECT EXISTING AND NEW WORK FROM EXTREMES OF TEMPERATURE. PROVIDE HEAT AND HUMIDITY CONTROL AS NEEDED TO PREVENT DAMAGE TO REMAINING EXISTING WORK AND TO NEW WORK.
- D. PROVIDE TEMPORARY ENCLOSURES TO SEPARATE WORK AREAS FROM AREAS OCCUPIED BY OWNER.
- E. COORDINATE REQUIRED SAW CUTTING OF SLAB WITH NEW PLUMBING WORK.

PRODUCTS FOR PATCHING AND EXTENDING WORK

- A. NEW MATERIALS: MATCH EXISTING PRODUCTS AND WORK FOR PATCHING AND EXTENDING WORK. PROVIDE SAME PRODUCTS OR TYPES OF CONSTRUCTION AS THAT IN EXISTING STRUCTURE, AS NEEDED TO PATCH, EXTEND OR MATCH EXISTING WORK. PRESENCE OF A PRODUCT, FINISH OR TYPE OF CONSTRUCTION REQUIRES THAT PATCHING, EXTENDING OR MATCHING SHALL BE PERFORMED AS NECESSARY TO WORK COMPLETE AND CONSISTENT TO IDENTICAL STANDARDS OF QUALITY.
- B. TYPE AND QUALITY OF EXISTING PRODUCTS: DETERMINE BY INSPECTION AND TESTING PRODUCTS WHERE NECESSARY, REFERRING TO EXISTING WORK AS A STANDARD.



CONSULTANT INFO:

A TENANT IMPROVEMENT FOR:
**YOLO 911
 DISPATCH CENTER**
 35 N. COTTONWOOD ST.
 WOODLAND, CA 95695

ISSUE TYPE:

REVISIONS:

DATE: 12-21-23
 PROJECT NUMBER: 23-378
 DRAWING TITLE: DEMO FLOOR PLAN AND REFLECTED CEILING PLAN
 SHEET NUMBER: A2.1

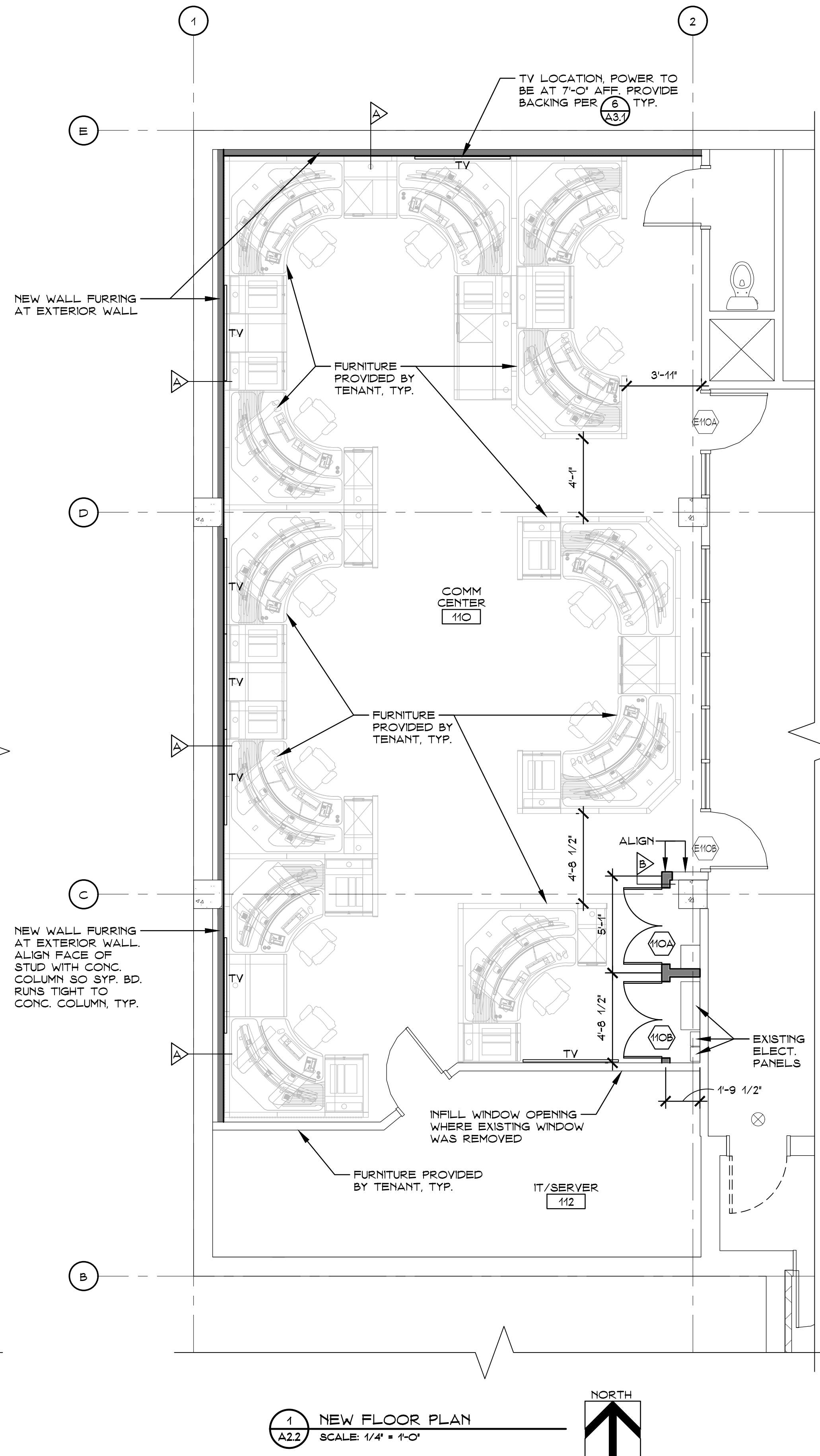
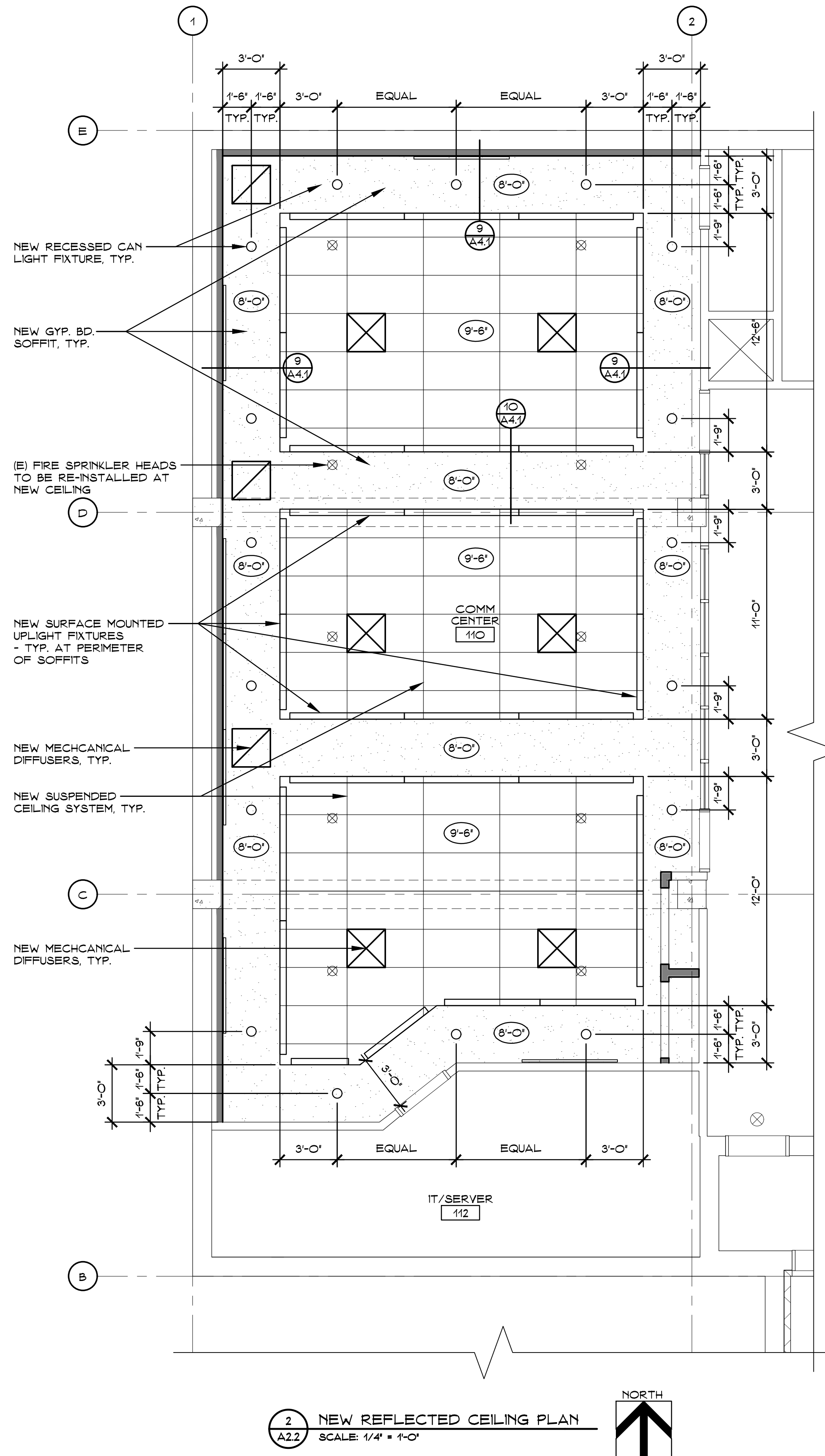

FLOOR PLAN LEGEND	
(E) WALL, TYP.	
NEW WALL, TYP.	
(N) WALL TYPE, SEE A4.1	
XXXX	ROOM NAME
XXX	ROOM NUMBER
(X'-XX)	CEILING HEIGHT

REFLECTED CEILING PLAN LEGEND	
[Grid]	NEW SUSPENDED CEILING SYSTEM
[X]	NEW MECHANICAL DIFFUSERS
[Hatched Box]	NEW FRAMED GYP. BD. SOFFIT
[Line]	NEW SURFACE MOUNTED UPLIGHT FIXTURE
[Circle]	NEW RECESSED CAN LIGHT FIXTURE

- REFLECTED CEILING PLAN NOTES**
- INSTALL CEILING TERMINATIONS ALONG WALL WHERE WALLS BREAK GRID
 - ALL PENETRATIONS THRU CEILING SHALL HAVE A MINIMUM 1" CLEARANCE TO ALLOW FOR LATERAL MOVEMENT.
 - REFERENCE THE FOLLOWING LATERAL & BRACING DETAILS:
 - (3) (A4.1) - METAL SUSPENSION SYSTEM
 - (4) (A4.1) - LIGHT FIXTURE SUPPORT
 - (5) (A4.1) - LATERAL FORCE BRACING
 - (6) (A4.1) - VERTICAL COMPRESSION BRACE
 - (7) (A4.1) - SEISMIC JOINT CLIP AT CROSS TEE
 - (8) (A4.1) - SYSTEM EDGE CONDITION
 - ILLUMINATION TO COMPLY WITH 2022 CBC SECTION 1008.1 THRU 1008.3.5

PERKINS, WILLIAMS & COTTELL, INC.
ARCHITECTS
 3329 Data Drive, Suite 200 - Rancho Cordova, California 95670
 T: (916) 851-1400 F: (916) 851-1408 E: pwcarch@pwcarchitects.com



CONSULTANT INFO:

A TENANT IMPROVEMENT FOR:
YOLO 911 DISPATCH CENTER
 35 N. COTTONWOOD ST.
 WOODLAND, CA 95695

ISSUE TYPE:

REVISIONS:

DATE: 12-21-23
 PROJECT NUMBER: 23-378
 DRAWING TITLE: NEW FLOOR PLAN AND REFLECTED CEILING PLAN
 SHEET NUMBER:

A2.2

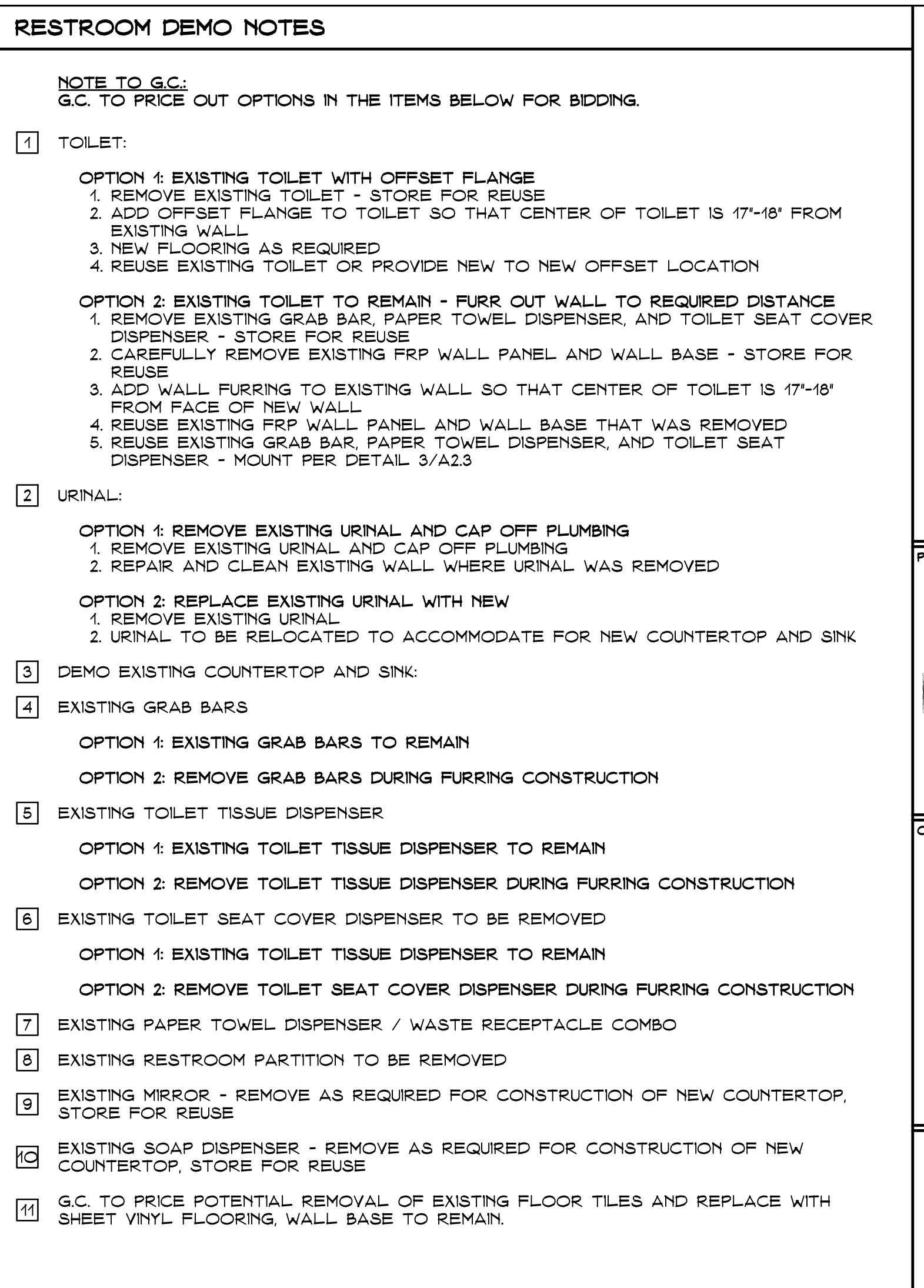
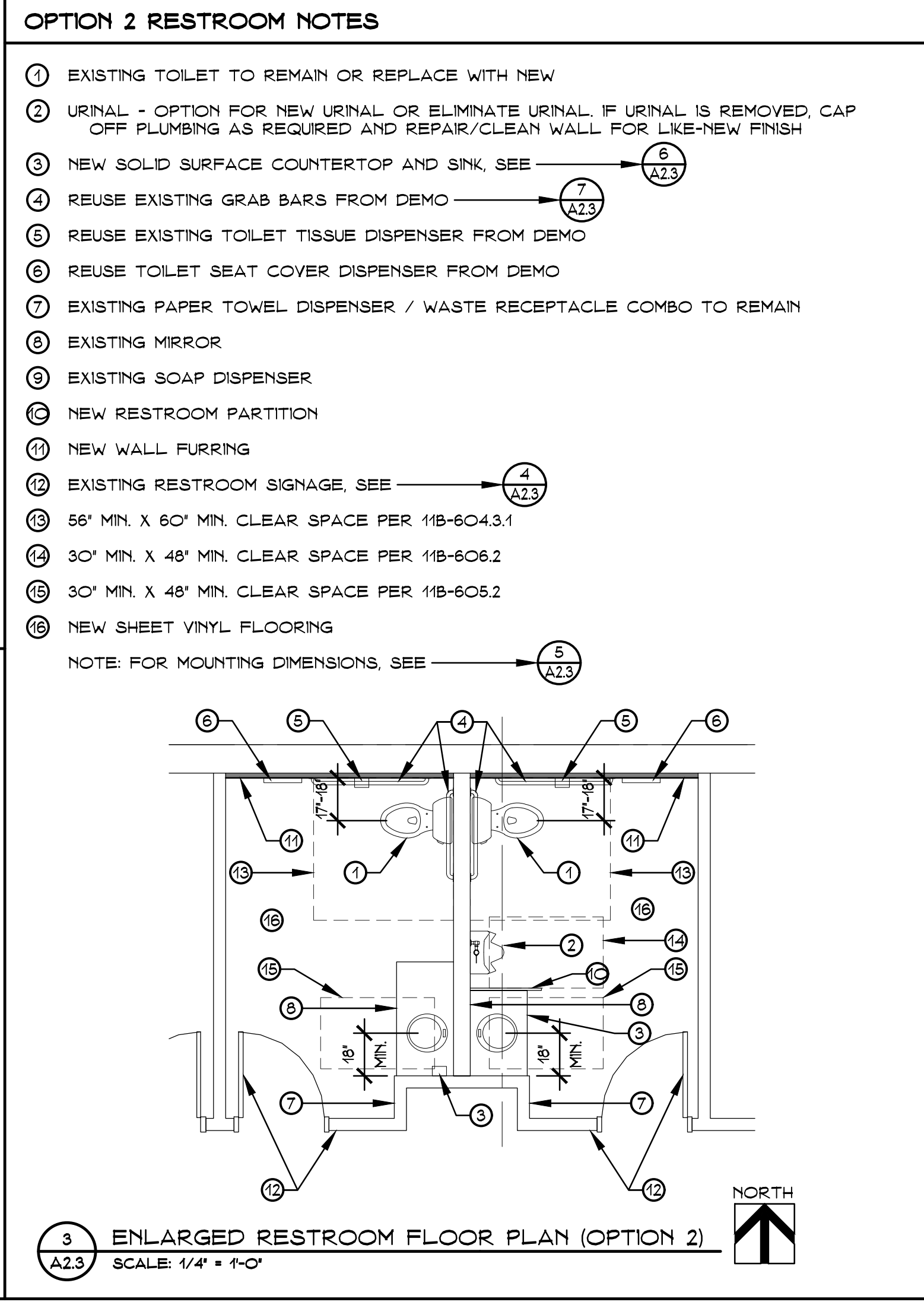
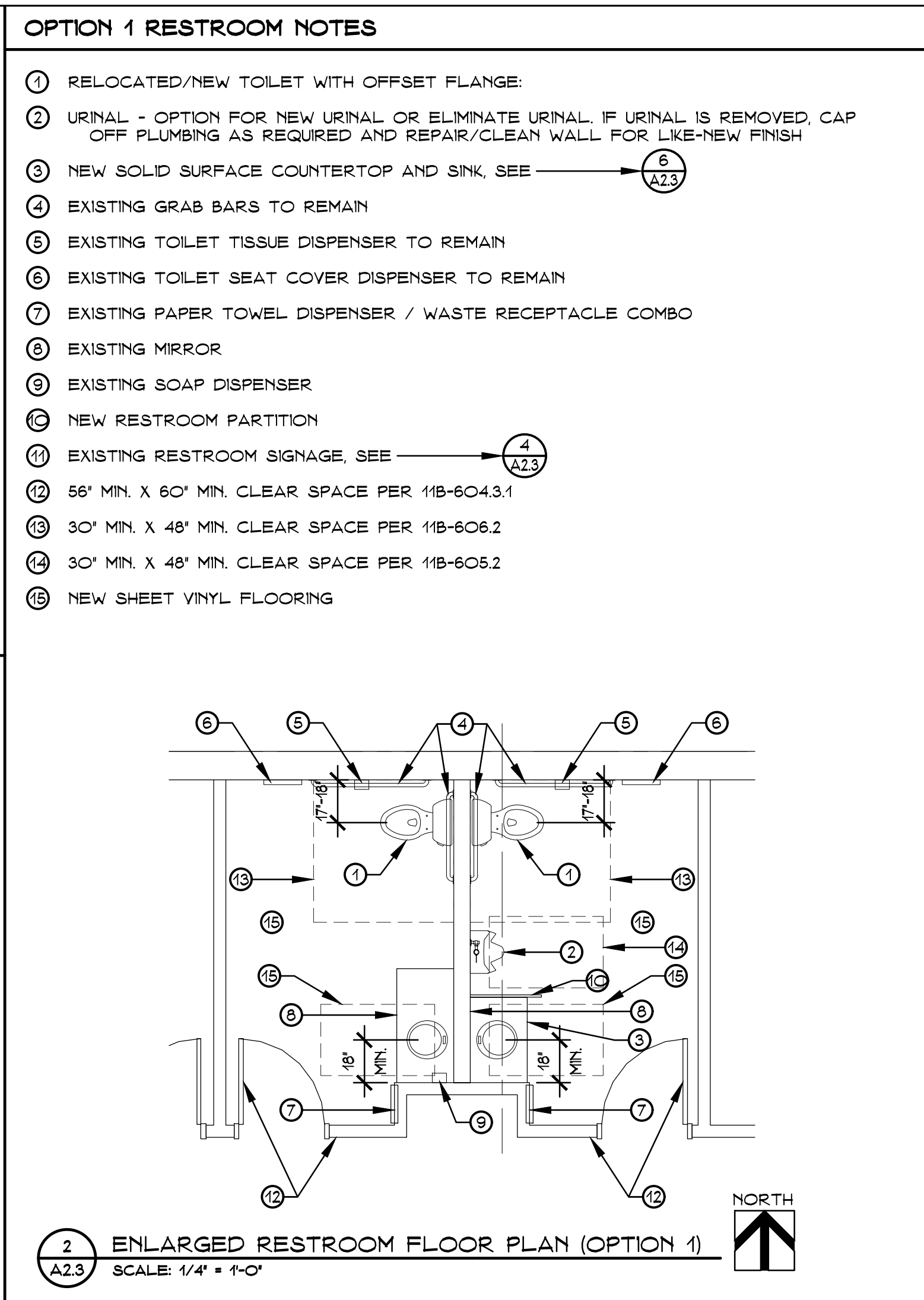
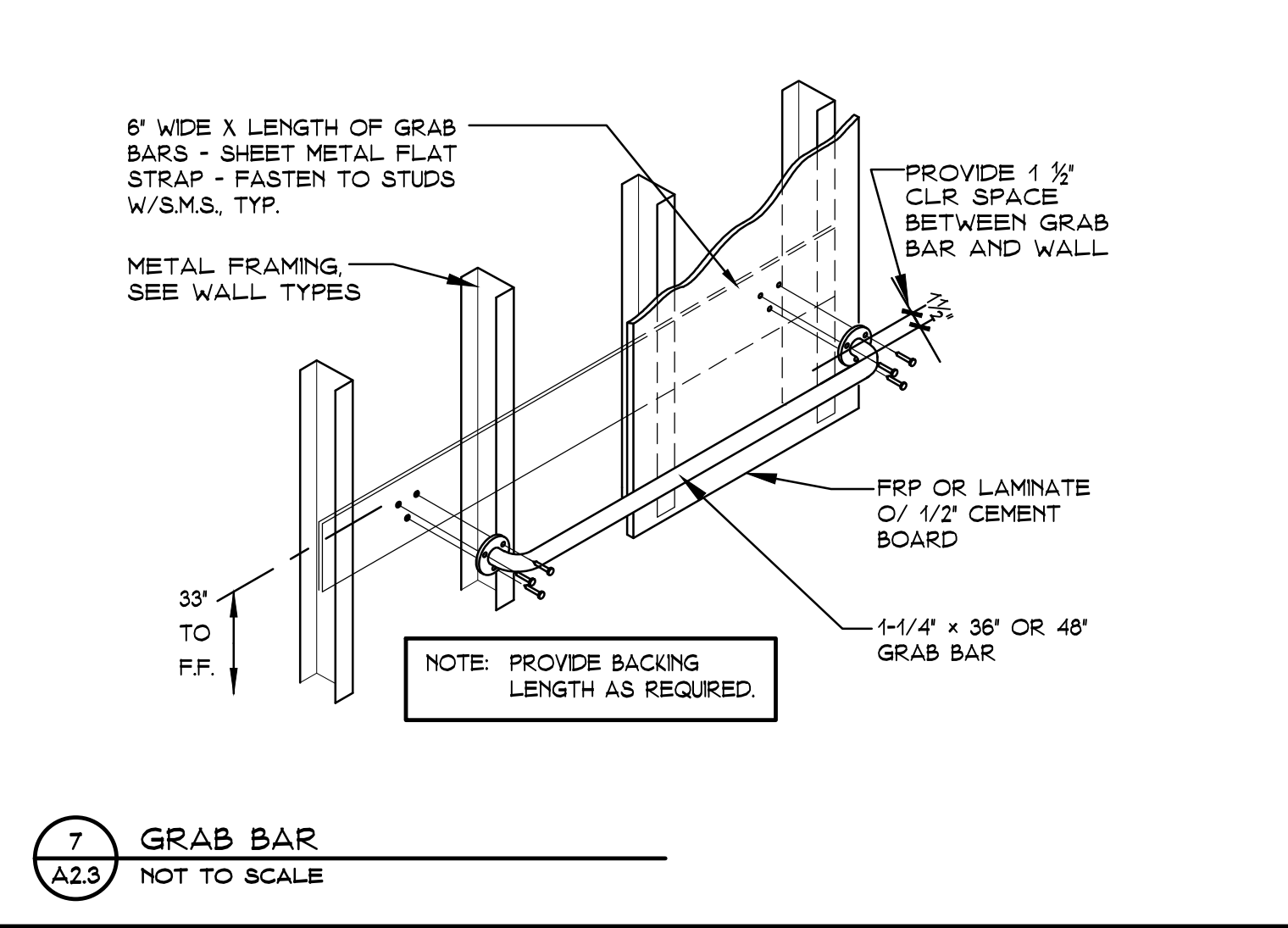
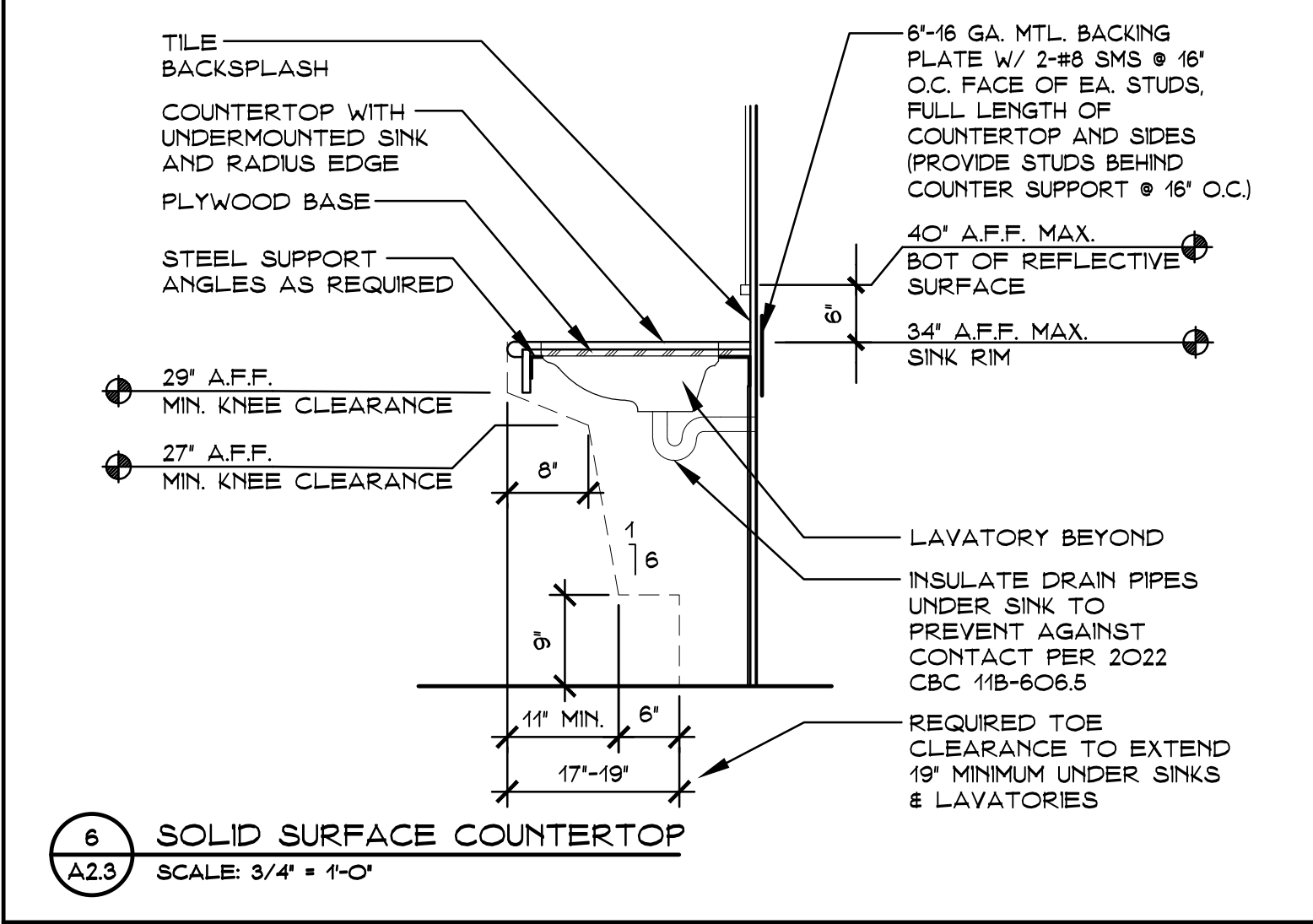
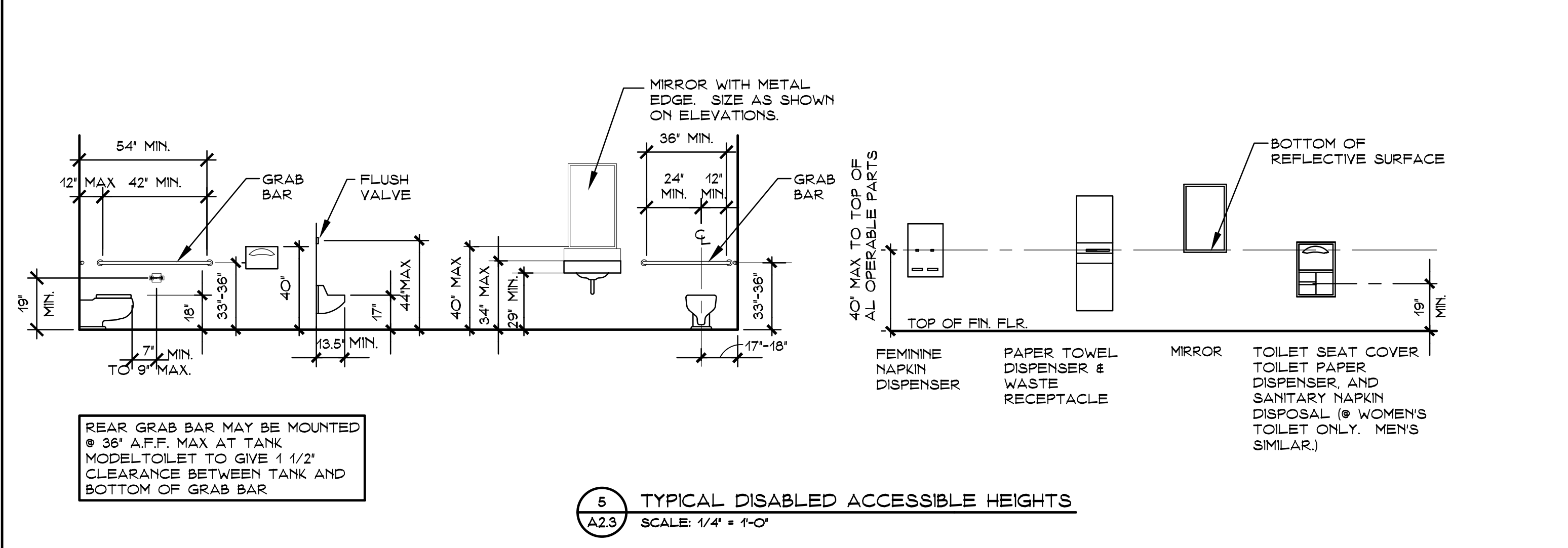
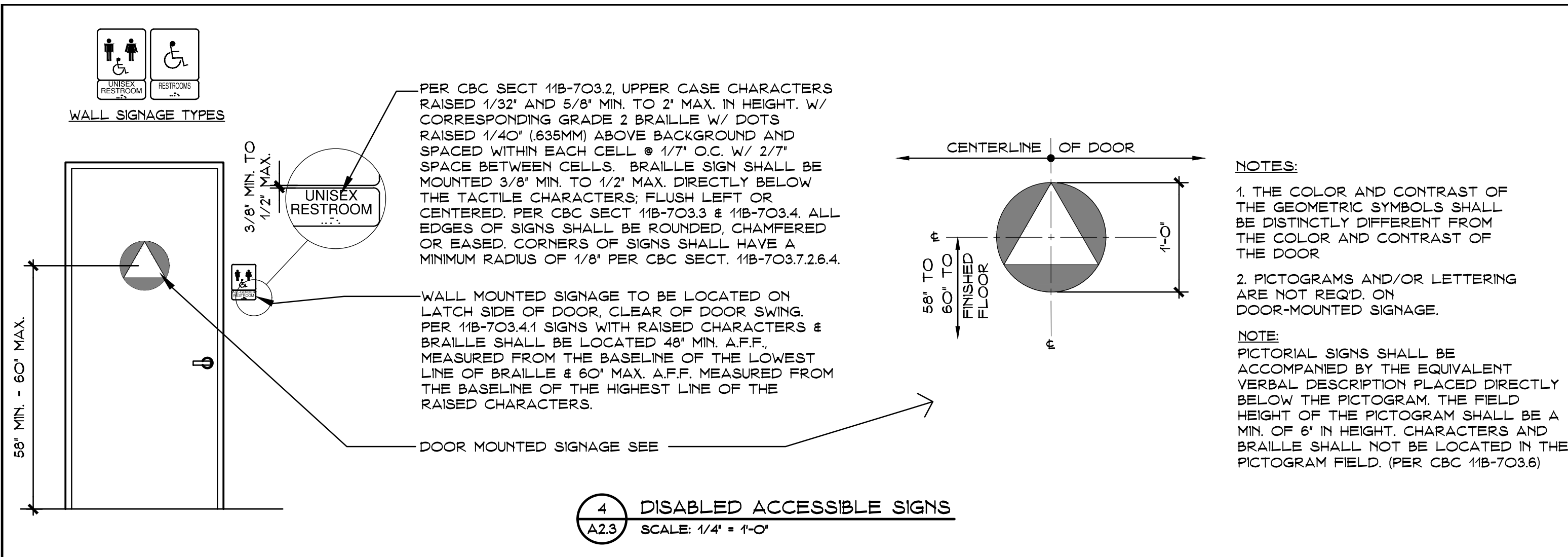

PERKINS, WILLIAMS & COTTELL, INC.
ARCHITECTS
3320 Data Drive, Suite 200 - Rancho Cordova, California 95670
T: (916) 851-1400 F: (916) 851-1408 E: pwcarch@pwcarchitects.com

PROFESSIONAL STAMP



CONSULTANT INFO

A TENANT IMPROVEMENT FOR:
YOLO 911 DISPATCH CENTER
35 N. COTTONWOOD ST.
WOODLAND, CA 95695

ISSUE TYPE:

REVISIONS:

DATE: 12-21-23
PROJECT NUMBER: 23-378
DRAWING TITLE: ENLARGED RESTROOMS & DETAILS
SHEET NUMBER:

A2.3

PROFESSIONAL STAMP



CONSULTANT INFO:

A TENANT IMPROVEMENT FOR:
YOLO 911
DISPATCH CENTER
 35 N. COTTONWOOD ST.
 WOODLAND, CA 95695

ISSUE TYPE:

REVISIONS:

DATE: 12-21-23
 PROJECT NUMBER: 23-378
 DRAWING TITLE: DOOR SCHEDULE & DETAILS
 SHEET NUMBER:

A3.1

DOOR SCHEDULE

OPENING NUMBER	DOOR TYPE	CLOSER	THRESHOLD	HARDWARE GROUP	PANIC HARDWARE	SEE FLOOR PLAN FOR EXACT DOOR LOCATIONS	INSTALLATION REMARKS
E101	-	●	●	E1	●		REPLACE THRESHOLD WITH NEW ADA COMPLIANT THRESHOLD
E110A	1			4			REPLACE DOOR KNOB WITH W/ NEW PER HARDWARE NOTE 3
E110B	1			4			REPLACE DOOR KNOB WITH W/ NEW PER HARDWARE NOTE 3
E122	-	●	●	E2	●		
E134	-	●	●	E1	●		

EXISTING DOORS

DOOR	TYPE	CLOSER	THRESHOLD	HARDWARE GROUP	PANIC HARDWARE
E101	-	●	●	E1	●
E110A	1			4	
E110B	1			4	
E122	-	●	●	E2	●
E134	-	●	●	E1	●

NEW DOORS

DOOR	TYPE	CLOSER	THRESHOLD	HARDWARE GROUP	PANIC HARDWARE
110A	A			2	
110B	A			2	

HARDWARE GROUPS

EXISTING GROUP #1 (ENTRANCE):
 ENTRANCE LOCKSET
 HINGES
 PANIC DEVICE
 CLOSER

EXISTING GROUP #2 (HOLLOW METAL DOOR):
 ENTRANCE LOCKSET
 HINGES
 CLOSERS

GROUP #1:
 NEW PASSAGE LEVER SET
 NEW HINGES
 NEW DOOR SILENCERS

GROUP #2:
 1 EA. PASSAGE LEVER SET
 6 PR. HINGES
 1 EA. DOOR SILENCERS

HARDWARE NOTES

- MAXIMUM EFFORT TO OPERATE DOORS SHALL COMPLY TO 2022 C.B.C. 1010.13, EXTERIOR DOORS SHALL HAVE A MAXIMUM FORCE OF 5 POUNDS, INTERIOR DOORS HAVE A MAXIMUM FORCE OF 5 POUNDS. REQUIRED FIRE DOORS SHALL HAVE THE MINIMUM OPENING FORCE ALLOWABLE BY CODE, NOT TO EXCEED 15 POUNDS.
- ALL EXIT DOORS SHALL BE OPERABLE FROM THE INSIDE WITHOUT THE USE OF A KEY OR ANY SPECIAL KNOWLEDGE OR EFFORT PER SECTION 1010.2, 2022 C.B.C.
- DOOR HANDLES, PULLS, LATCHES, LOCKS & OTHER OPERATING DEVICES ON DOORS REQUIRED TO BE ACCESSIBLE SHALL NOT REQUIRE TIGHT GRASPING, TIGHT PINCHING OR TWISTING OF THE WRIST TO OPERATE PER SECTION 1010.2.2, 2022 C.B.C.
- DOOR HANDLES, PULLS, LATCHES, LOCKS & OTHER OPERATING DEVICES SHALL BE INSTALLED 34" MINIMUM & 44" MAXIMUM ABOVE THE FLOOR PER SECTIONS 1010.2.3, 2022 C.B.C.
- MANUALLY OPERATED FLUSH BOLTS OR SURFACE BOLTS OR ANY OTHER DEVICE THAT MAY BE USED TO CLOSE OR RESTRAIN THE DOOR OTHER THAN BY OPERATION OF THE LOCKING DEVICE SHALL NOT BE PERMITTED PER SECTION 1010.2.5, 2022 C.B.C.
 -BOLT LOCKS ARE ALLOWED WHERE DOORS MEET SECTION 1010.2.5, 2022 C.B.C. EXCEPTIONS #1 THRU #5.
- THE UNLATCHING OF ANY DOOR OR LEAF SHALL NOT REQUIRE MORE THAN ONE MOTION PER SECTION 1010.2.4, 2022 C.B.C.
- PER SECTION 1010.2.9.3, 2022 C.B.C. WHERE PANIC AND FIRE EXIT HARDWARE IS INSTALLED, IT SHALL COMPLY WITH THE FOLLOWING:
 -THE ACTUATING PORTION OF THE RELEASING DEVICE SHALL EXTEND NOT LESS THAN ONE-HALF OF THE DOOR LEAF WIDTH.
 -THE MAX. UNLATCHING FORCE SHALL NOT EXCEED 15 LBS.
- PER SECTION 11B-404.2.8 DOORS EQUIPPED W/ A CLOSER SHALL BE ADJUSTED SO THAT FROM AN OPEN POSITION OF 90 DEGREES, THE TIME REQUIRED TO MOVE THE DOOR TO A POSITION OF 12 DEGREES FROM THE LATCH IS 5 SECONDS MINIMUM.
- LATCHING AND LOCKING DOORS THAT ARE HAND ACTIVATED AND WHICH ARE IN A PATH OF TRAVEL SHALL BE OPERATED BY LEVER-TYPE HARDWARE, PANIC HARDWARE, PUSH-PULL ACTIVATING BARS, U-SHAPED HANDLES, OR OTHER HARDWARE DESIGNED TO PROVIDE PASSAGE PER 11B-404.2.7.
- ENTRANCE/EXIT MAY USE KEY-LOCKING HARDWARE WITH A SIGN ABOVE THE DOOR WHICH READS: "THIS DOOR TO REMAIN UNLOCKED WHEN BUILDING IS OCCUPIED", PER 2022 C.B.C. SEE 1010.2.4. THE SIGN SHALL BE IN LETTERS 1" HIGH ON A CONTRASTING BACKGROUND AND USE OF THE KEY-OPERATED LOCKING DEVICE IS REVOCABLE BY THE BUILDING OFFICIAL FOR DUE CAUSE.
 T = TEMPERED GLASS TO COMPLY WITH SECTION 2406.3, 2022 C.B.C.
- PROVIDE INTERNATIONAL SYMBOL OF ACCESSIBILITY AT STRIKE SIDE OF EXTERIOR DOORS WHEN POSSIBLE, MOUNTED AT +60" AFF.
- SWINGING DOOR SURFACES WITHIN 10 INCHES OF THE FINISH FLOOR OR GROUND MEASURED VERTICALLY SHALL HAVE A SMOOTH SURFACE ON THE PUSH SIDE EXTENDING THE FULL WIDTH OF THE DOOR OR GATE. PARTS CREATING HORIZONTAL OR VERTICAL JOINTS IN THESE SURFACES SHALL BE WITHIN 1/16" INCH OF THE SAME PLANE AS THE OTHER AND BE FREE OF SHARP OR ABRASIVE EDGES. CAVITIES CREATED BY ADDED KICK PLATES SHALL BE CAPPED. 2022 C.B.C. 11B-404.2.10.
- DOOR TO FIRE RISER MUST BE PERMANENTLY LABELED "FIRE CONTROL ROOM" IN FOUR-INCH LETTERS WITH A 1/2" STROKE AND CONTRASTING IN COLOR TO THE BACKGROUND
- CARD READERS DO NOT INHIBIT EGRESS AND SHALL COMPLY WITH 2022 C.B.C. 1010.2.10

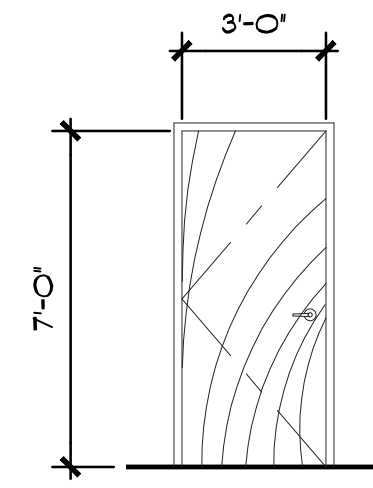

TYPE 1
 DOOR: 1 3/4" SOLID CORE WOOD
 FRAME: HOLLOW METAL FRAME

2
 A3.1 **EXISTING DOOR TYPES**
 SCALE: 1/4" = 1'-0"

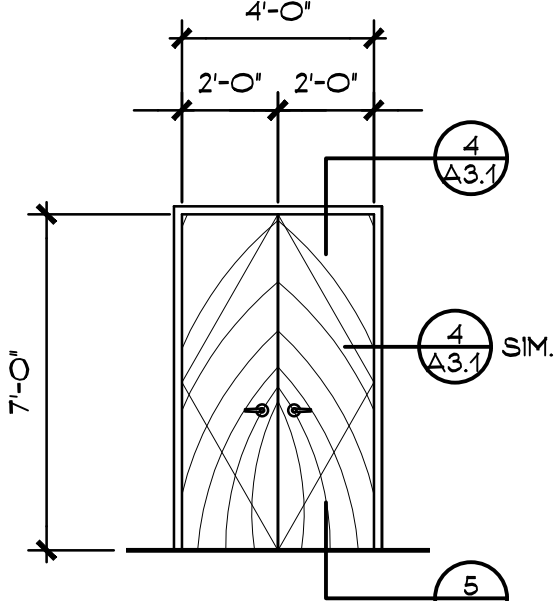

TYPE A
 DOOR: 1 3/4" SOLID CORE WOOD
 FRAME: TIMELY METAL FRAME

3
 A3.1 **NEW DOOR TYPES**
 SCALE: 1/4" = 1'-0"

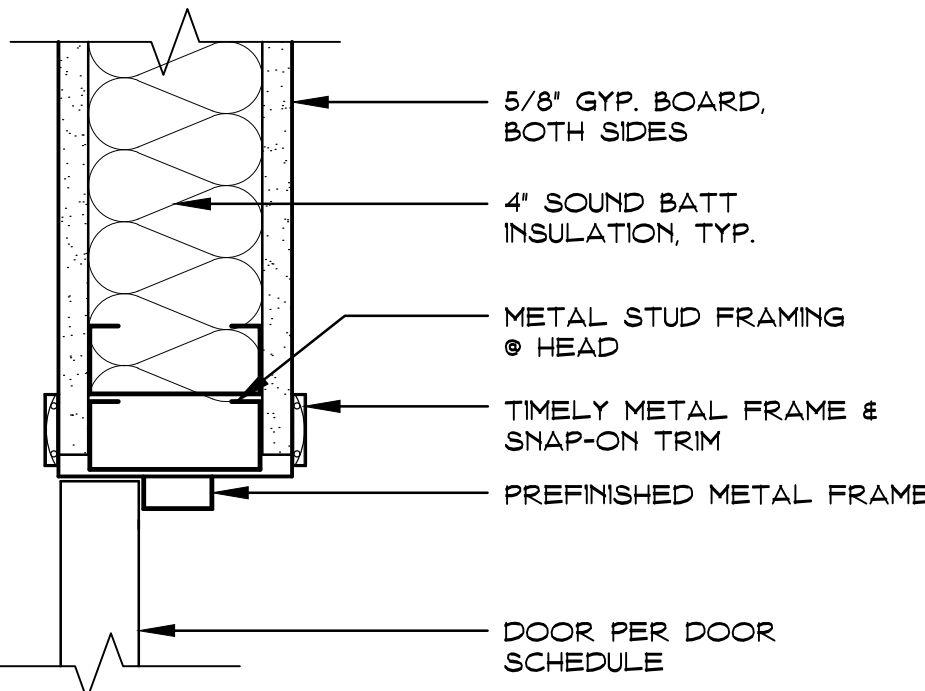

4
 A3.1 **HEAD @ INTERIOR DOOR**
 SCALE: 3" = 1'-0" (JAMB SIM.)

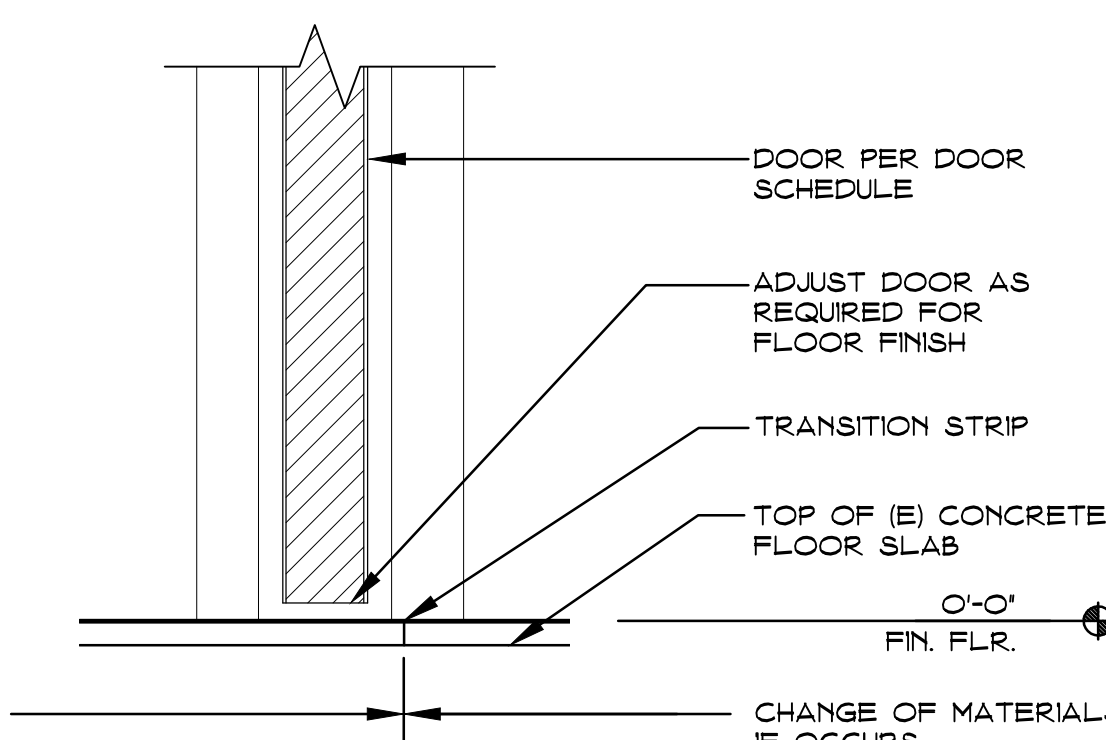

5
 A3.1 **INTERIOR DOOR W/ OUT THRESHOLD**
 SCALE: 3" = 1'-0"

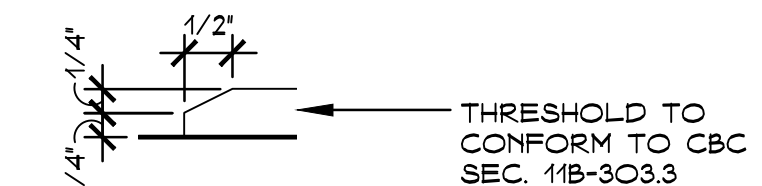

1
 A3.1 **DOOR THRESHOLD**
 SCALE: 6" = 1'-0"

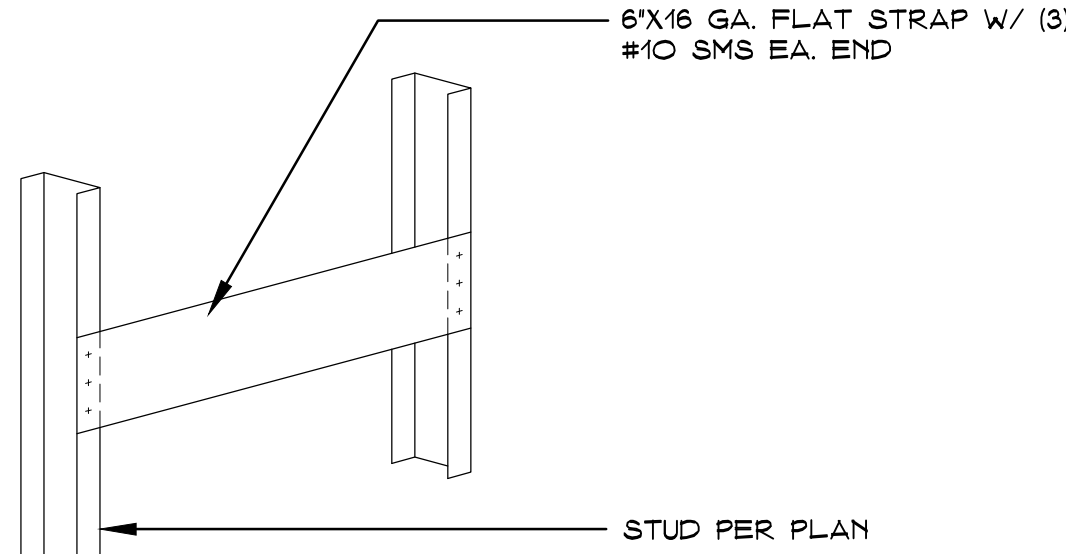

DETAIL A
 ACCEPTABLE FOR HANGING PICTURES, MIRRORS, SOAP DISPENSERS, & HAND DRYERS

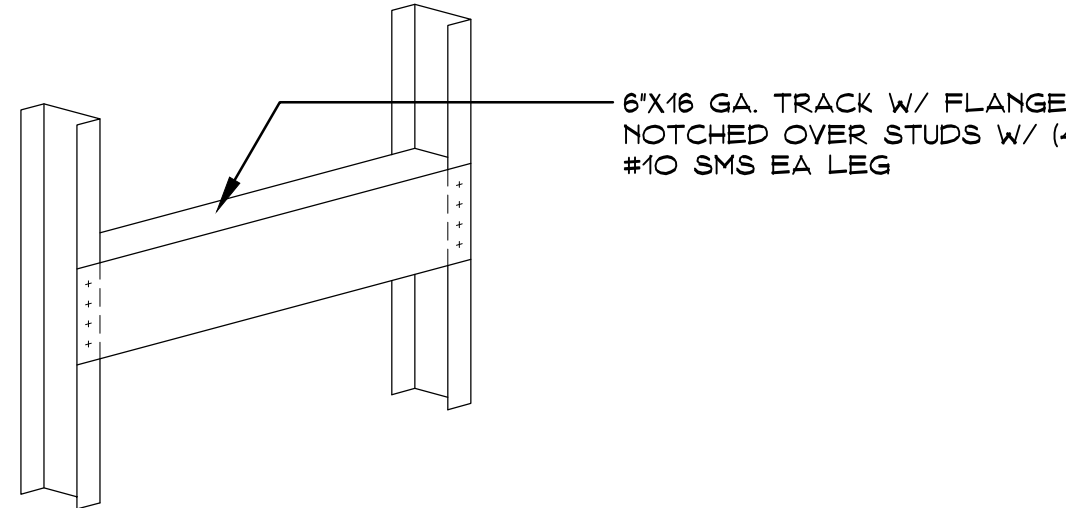

DETAIL B
 ACCEPTABLE FOR HANGING WALL STANDARDS & WALL-HUNG CABINETS

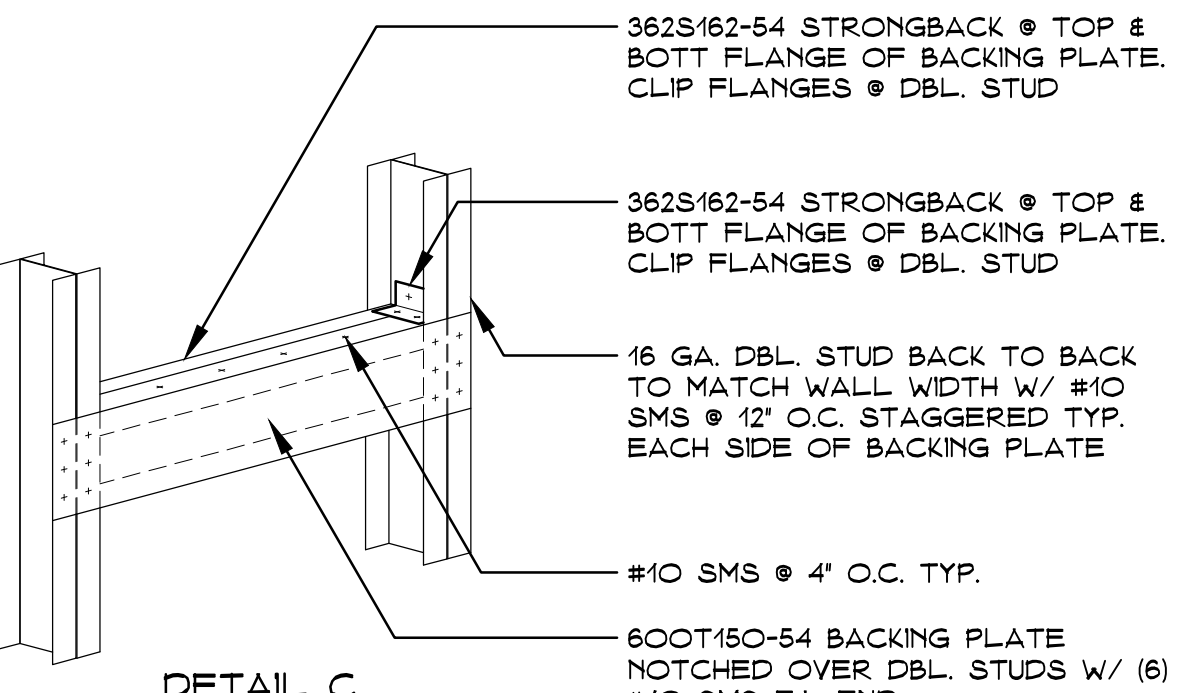

DETAIL C
 ACCEPTABLE FOR HANGING FLAT-SCREEN TV'S, GRAB BARS, & ALL ITEMS NOT LISTED IN A & B

6
 A3.1 **TYPICAL MOUNTING DETAILS**
 1" = 1'-0"

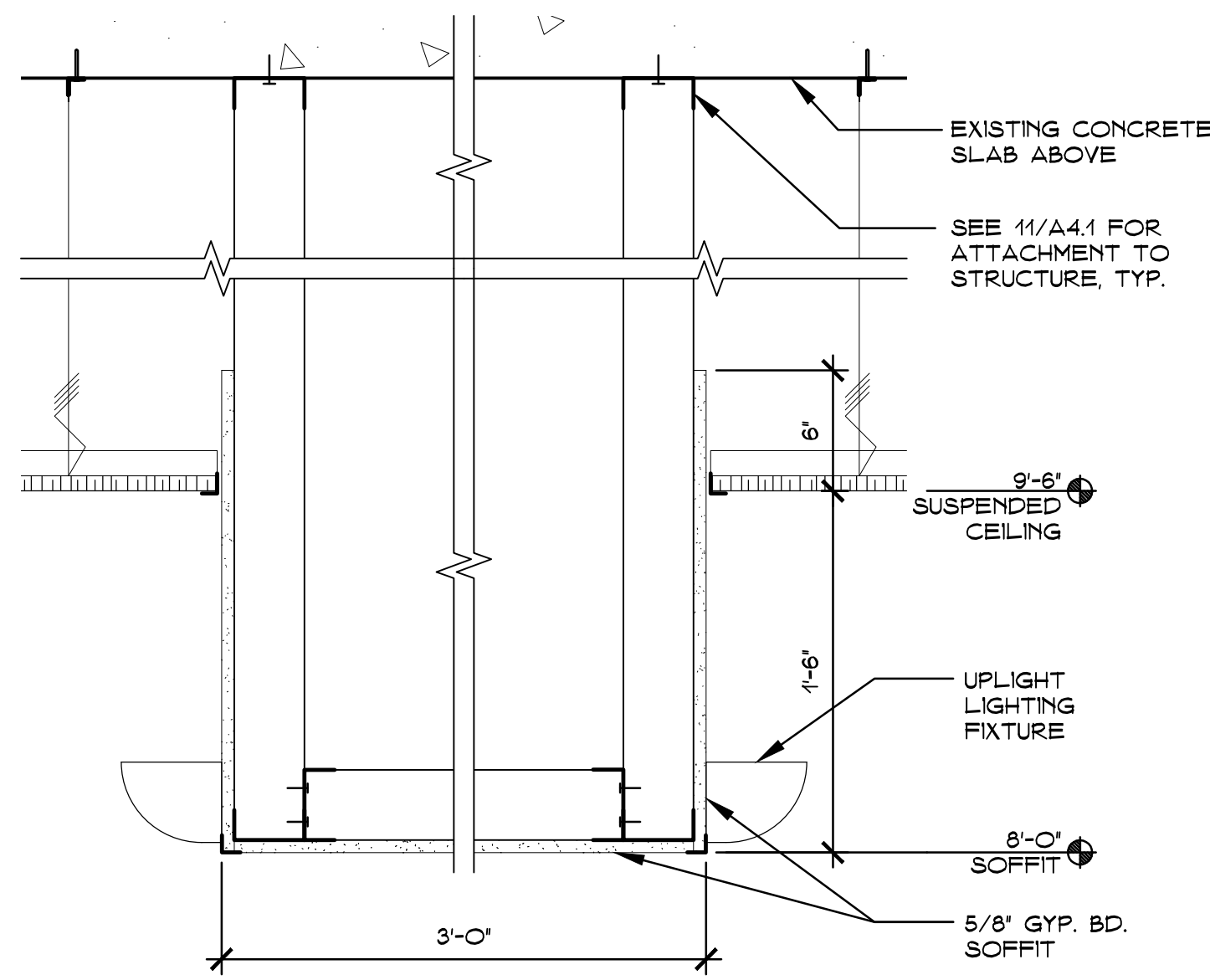

10 SOFFIT DETAIL
A4.1 SCALE: 1 1/2" = 1'-0"

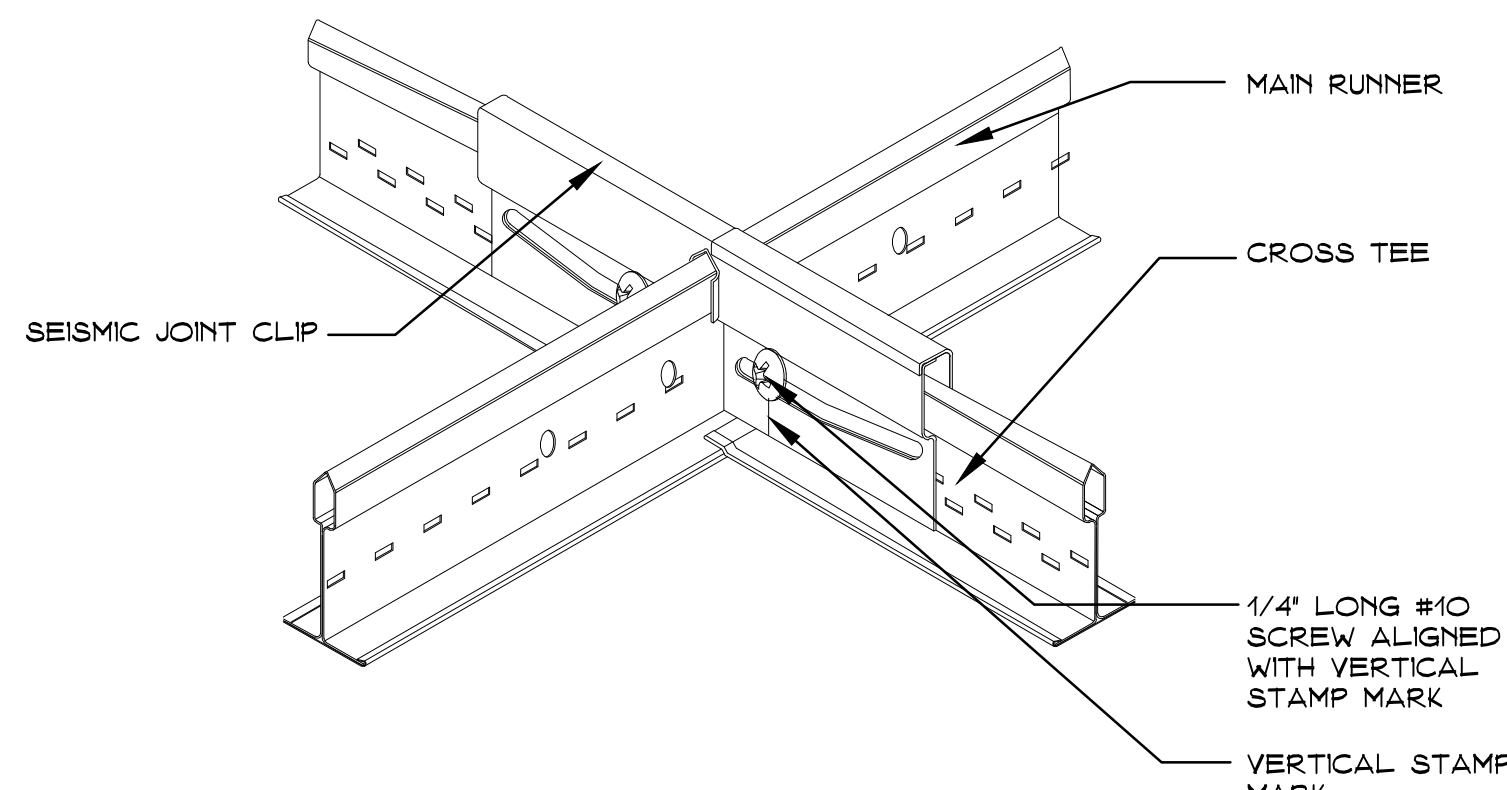

PLACE SEISMIC SEPARATIONS SO NON-SEPARATED SUSPENSION CEILING AREA DOES NOT EXCEED 2500 SF.

SUSPENSION SYSTEM SHALL BE RATED FOR CATEGORY 'D' SEISMIC DESIGN AND SHALL BE OF 'HEAVY-DUTY' TYPE.

7 SEISMIC JOINT CLIP AT CROSS TEE
A4.1 NOT TO SCALE

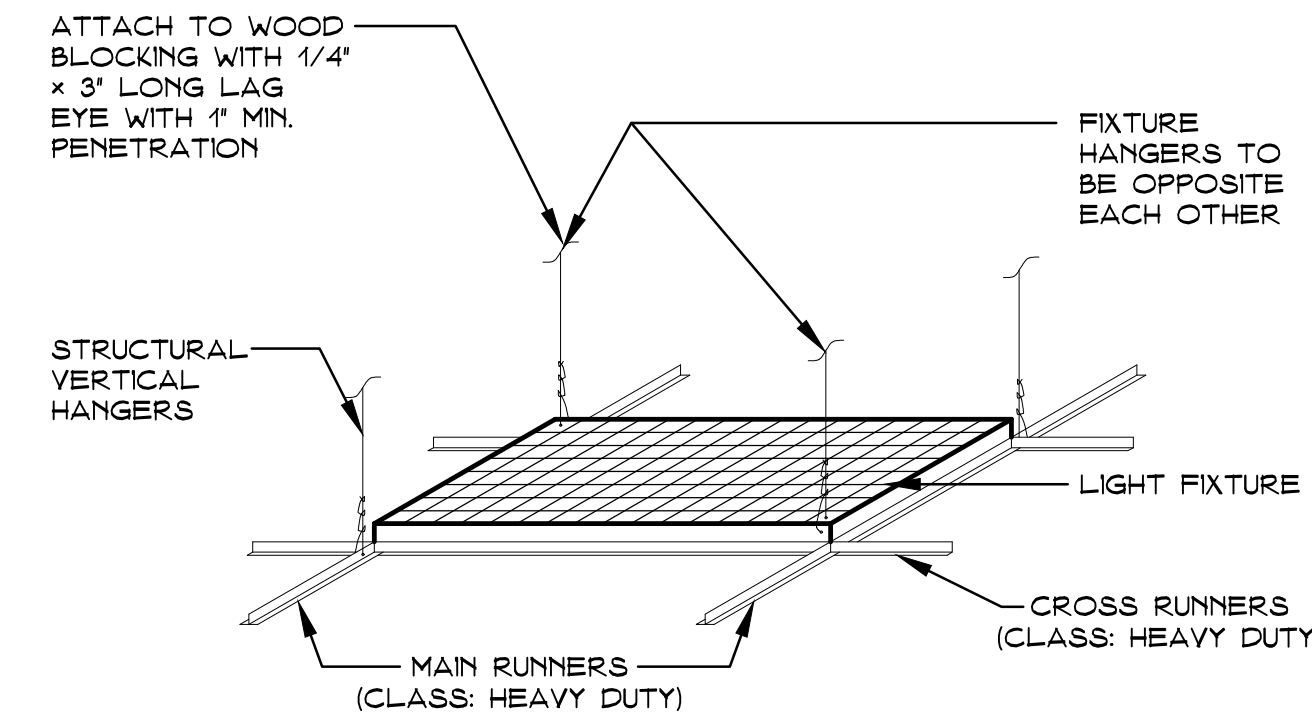

NOTE:
- ALL WIRES TO BE NOT LESS THAN 12 GA.
- ALL WIRES TO HAVE MIN. 3 TURNS, BOTH ENDS.
- IF FIXTURE EXCEEDS 55 LBS. THEN WIRES USED FOR FIXTURE SUPPORT MUST BE FASTENED TO BUILDING STRUCTURE.
- ALL LIGHTING FIXTURES SHALL BE POSITIVELY ATTACHED TO SUSPENDED CEILING SYSTEM PER CIGSA RECOMMENDATIONS.

SUSPENSION SYSTEM SHALL BE RATED FOR CATEGORY 'D' SEISMIC DESIGN AND SHALL BE OF 'HEAVY-DUTY' TYPE.

4 LIGHT FIXTURE SUPPORT
A4.1 NOT TO SCALE

FRAMING SCHEDULES

THIS INFORMATION TO BE WITH WALL TYPES SHOWN TO CONFIRM FRAMING DETAILS. COORDINATE WITH ARCHITECT WHERE FIELD CONDITIONS MAY VARY BEFORE BUILDING NEW WORK. BASED ON SCAFCO SPECIFICATION MANUAL.

CEILING JOIST FRAMING		BASED ON L/240 DEFLECTION	
SPAN	JOIST	SPACING	GAUGE
2'-0" TO 6'-0"	1 1/4" x 2 1/2"	24" O.C.	25 / 18 ML
6'-1" TO 15'-0"	1 5/8" x 4"	24" O.C.	20 / 33 ML
6'-1" TO 15'-0"	1 5/8" x 3 5/8"	16" O.C.	20 / 33 ML
15'-1" TO 20'-0"	1 5/8" x 6"	16" O.C.	20 / 33 ML
21'-1" TO 21'-10"	1 5/8" x 6"	16" O.C.	18 / 43 ML

NOTE: WHERE SPANS EXCEED 10'-0" PROVIDE 3 5/8" 25 GA. STUD STRONG BACKS ON TOP OF JOIST SET PERPENDICULAR EVERY 5'-0" O.C. OR AT THIRD POINTS OF SPANNED DISTANCE.

CEILING LOAD		
SUSP. CLG. SYSTEM		0.3
METAL FRAMING		2.8
INSULATION		0.7
MISC. MECH. & ELEC.		2.2
TOTAL DEAD LOAD		6.0 #/SQ.FT.

WALL STUD FRAMING BASED ON 5 PSF WINDLOAD & L/240 DEFLECTION

HEIGHT OF UNBRACED VERT. SPAN (COMPOSITE WALL SHEATHED BOTH SIDES)			
HEIGHT OF UNBRACED VERT. SPAN	STUD	SPACING	GAUGE
TO - 13'-5"	1 1/4" x 3 5/8"	24" O.C.	25 / 18 ML
TO - 14'-9"	1 1/4" x 3 5/8"	24" O.C.	20 / 33 ML
TO - 16'-5"	1 1/4" x 3 5/8"	16" O.C.	20 / 33 ML
TO - 21'-7"	1 1/4" x 6"	16" O.C.	20 / 33 ML

INSTALLATION OF STUD TRACKS AT FLOOR: 18 GA. X WIDTH TO MATCH STUD WALL FRAMING - SHOOT TO CONCRETE FLOOR WITH SIMPSON PDP4 0.157" DIA X 1" MIN. PER ICC ESR-2136

4 FRAMING NOTES & SCHEDULE
A4.1 NO SCALE

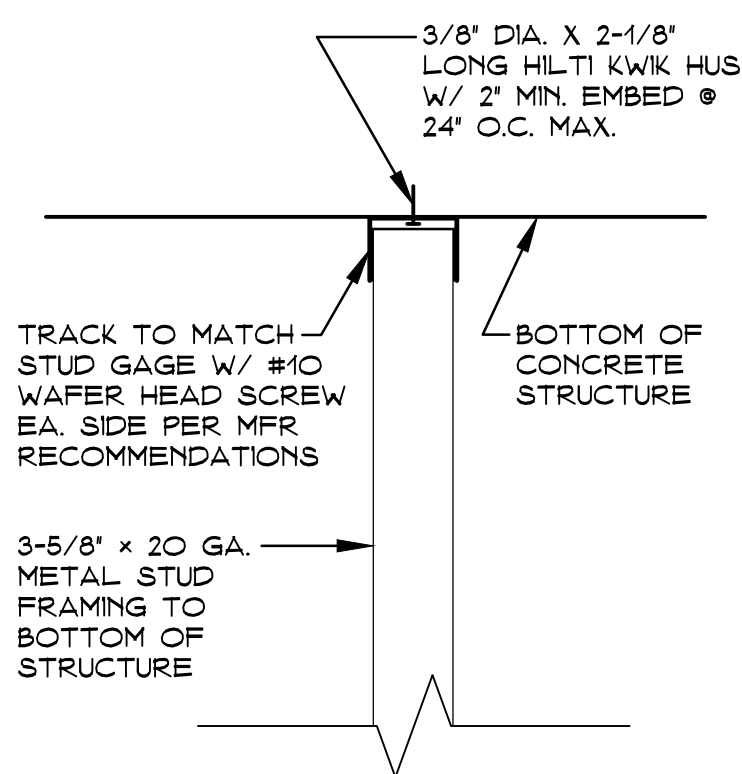

11 SOFFIT FRAMING CONNECTION ABOVE
A4.1 SCALE: 1 1/2" = 1'-0"

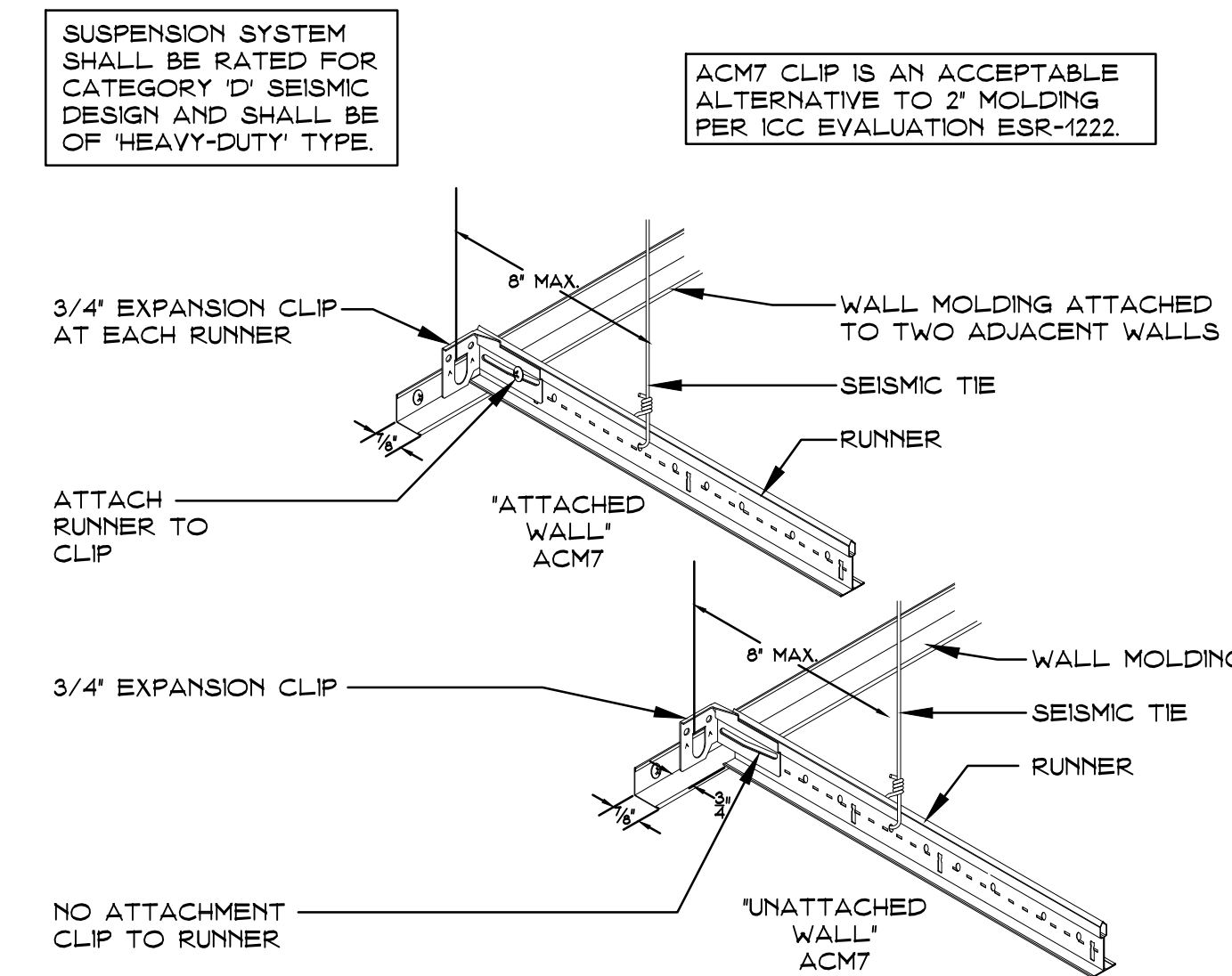

8 METAL SUSPENSION SYSTEM EDGE CONDITION
A4.1 NOT TO SCALE

FOUR 12 GA. WIRES SECURED TO THE MAIN RUNNER WITH FOUR TIGHT TWISTS IN 1 1/2" AND WITHIN 2" OF THE CROSS RUNNER AND SPAYED 90 DEGREES FROM EACH OTHER, AND AT ANGLE NOT EXCEEDING 45° FROM THE PLANE OF THE CEILING.
ALL SUSPENDED DUCTWORK AND EQUIPMENT SHALL BE 6" CLEAR FROM ALL CEILING SPLAY WIRES PER C.B.C. STANDARD 25-2
ENDS OF DROPS IN TILE GRID SHALL BE TIED TO PREVENT SPREADING AT THEIR PERIMETER.

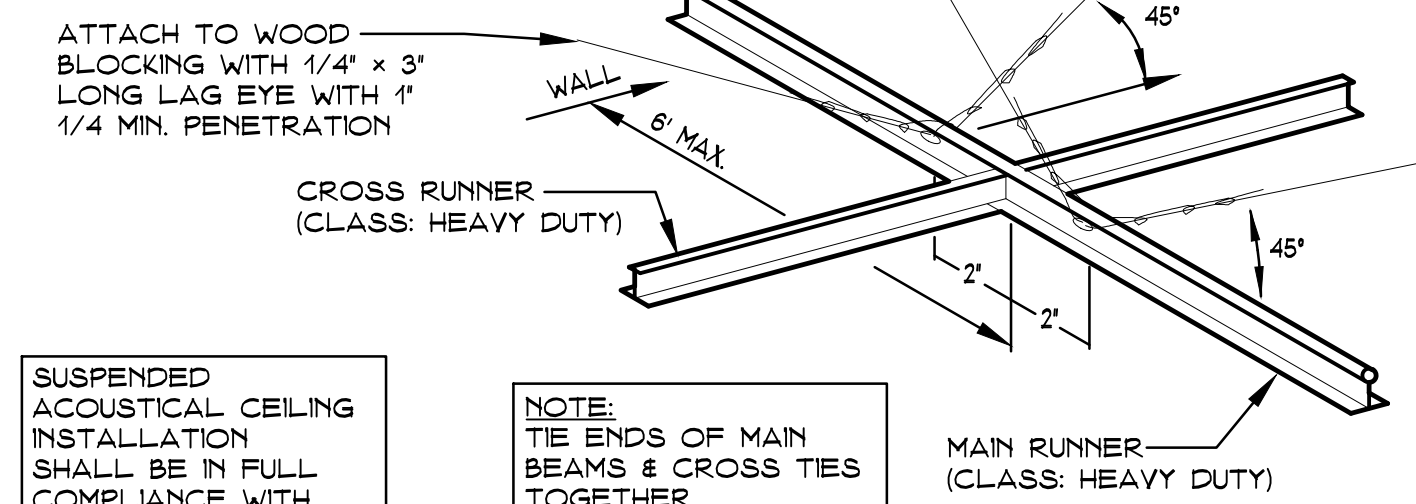

SUSPENDED ACOUSTICAL INSTALLATION SHALL BE IN FULL COMPLIANCE WITH CBC 1613 ACE7, ASCE 7-10 SECTION 11A13.9 & ASTM C635 & ASTM C636.

NOTE: TIE ENDS OF MAIN BEAMS & CROSS TIES TOGETHER.

SUSPENSION SYSTEM SHALL BE RATED FOR CATEGORY 'D' SEISMIC DESIGN AND SHALL BE OF 'HEAVY-DUTY' TYPE.

5 LATERAL FORCE BRACING
A4.1 NOT TO SCALE

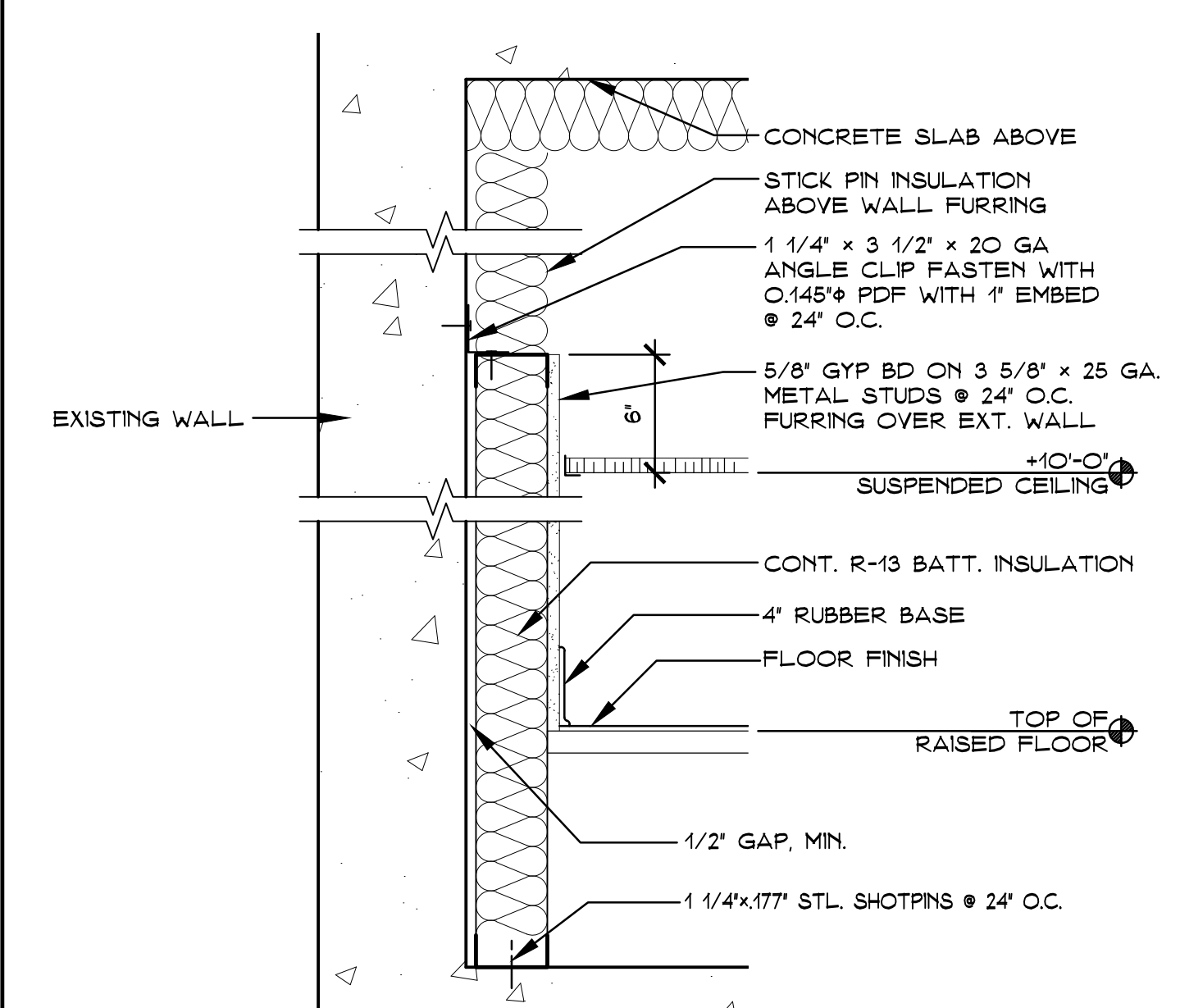

2 FURRED EXTERIOR WALL
A4.1 SCALE: 1 1/2" = 1'-0"

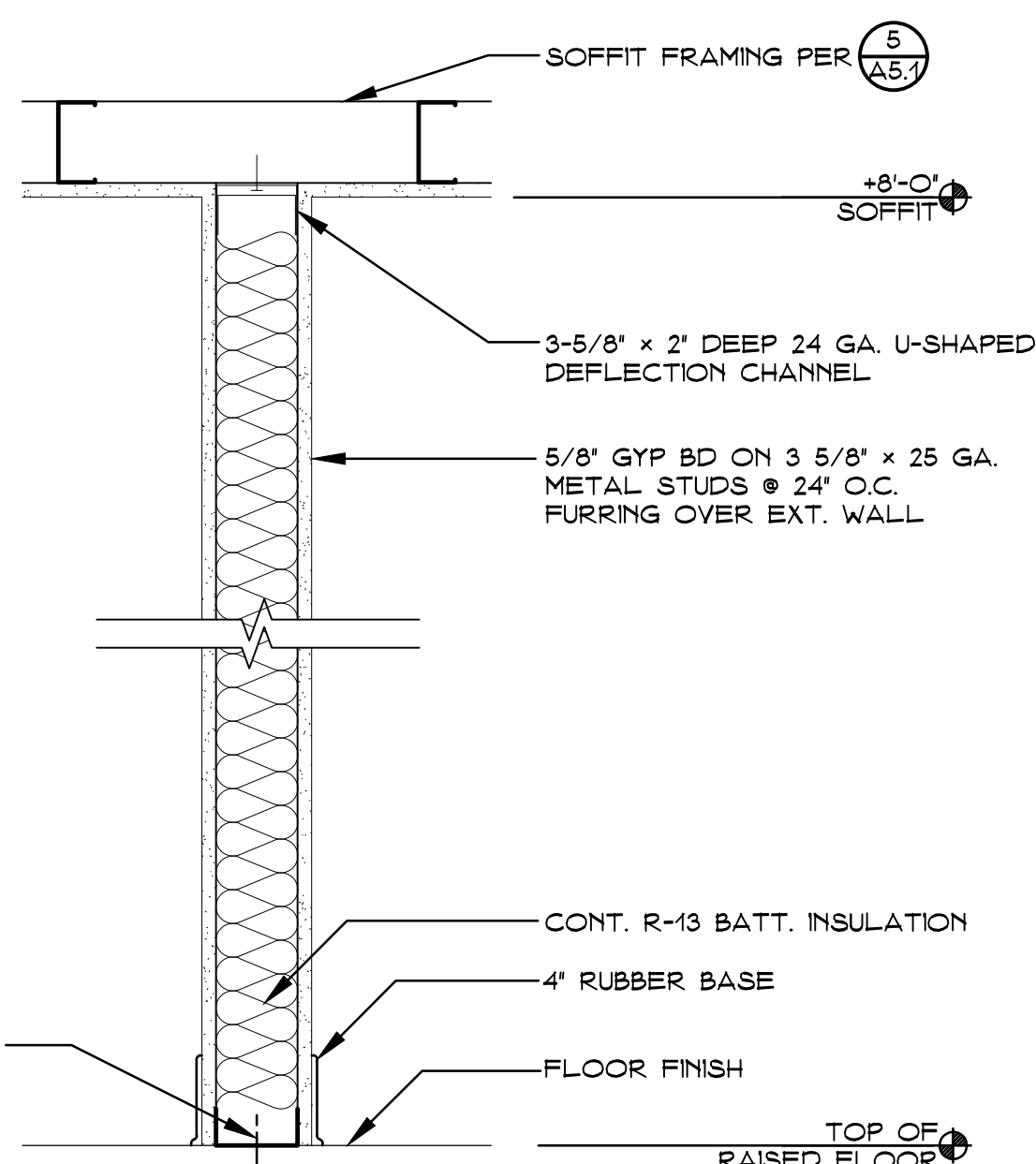

12 FURRED EXTERIOR WALL
A4.1 SCALE: 1 1/2" = 1'-0"

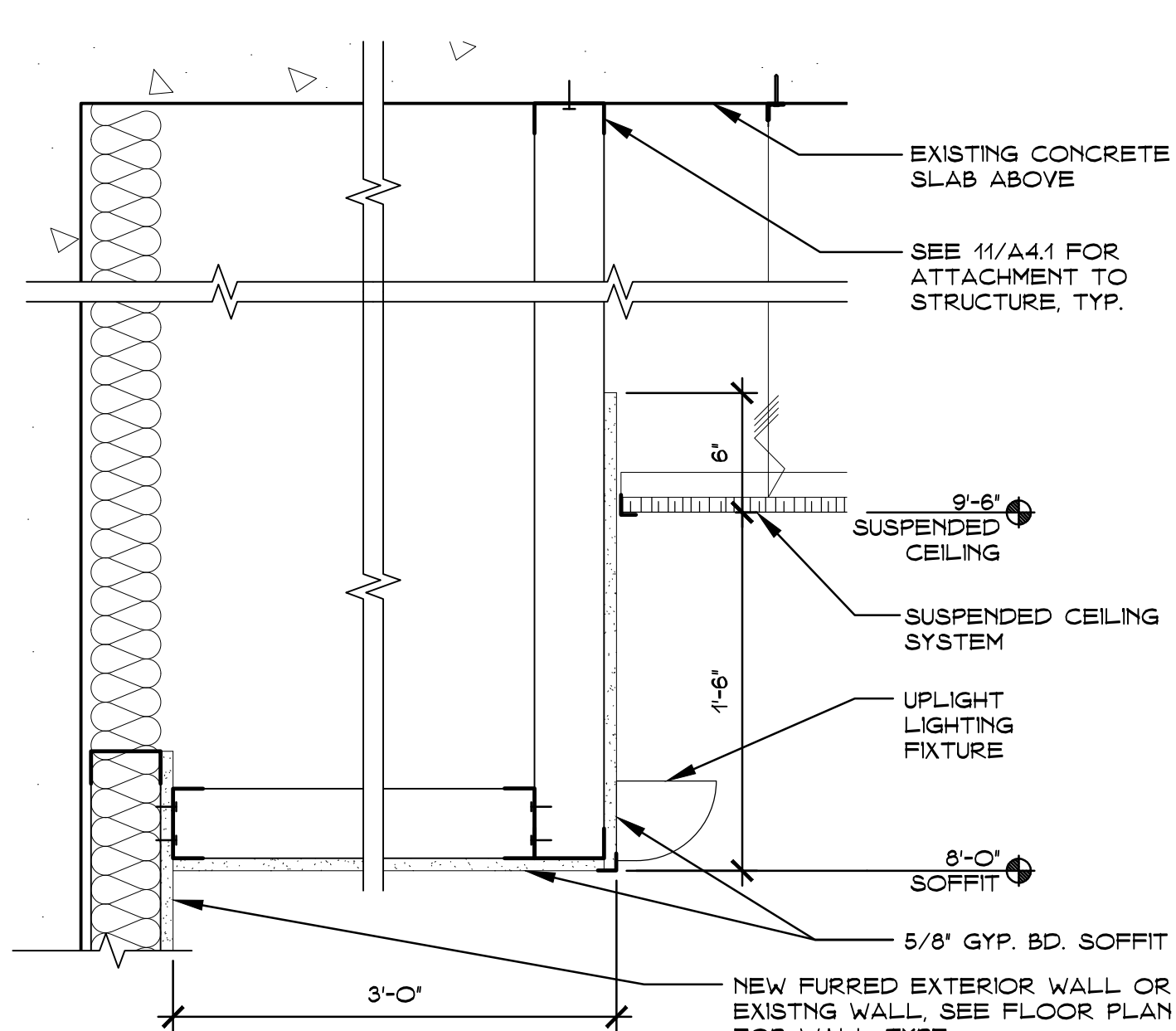

9 SOFFIT DETAIL
A4.1 SCALE: 1 1/2" = 1'-0"

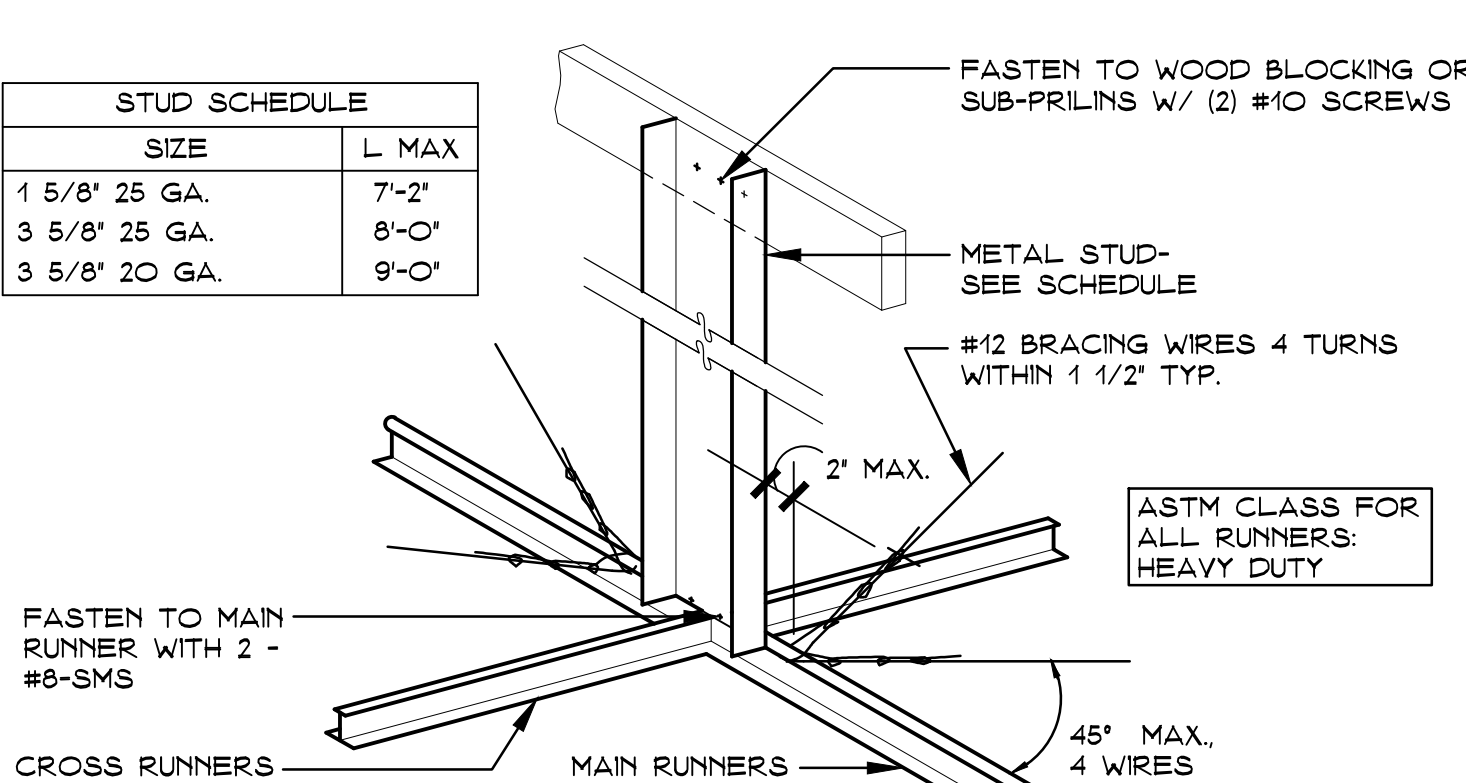

FASTEN TO MAIN RUNNER WITH 2 - #8-SMS

CROSS RUNNERS

6 VERTICAL COMPRESSION BRACE
A4.1 NOT TO SCALE

SUSPENSION SYSTEM SHALL BE RATED FOR CATEGORY 'D' SEISMIC DESIGN AND SHALL BE OF 'HEAVY-DUTY' TYPE.

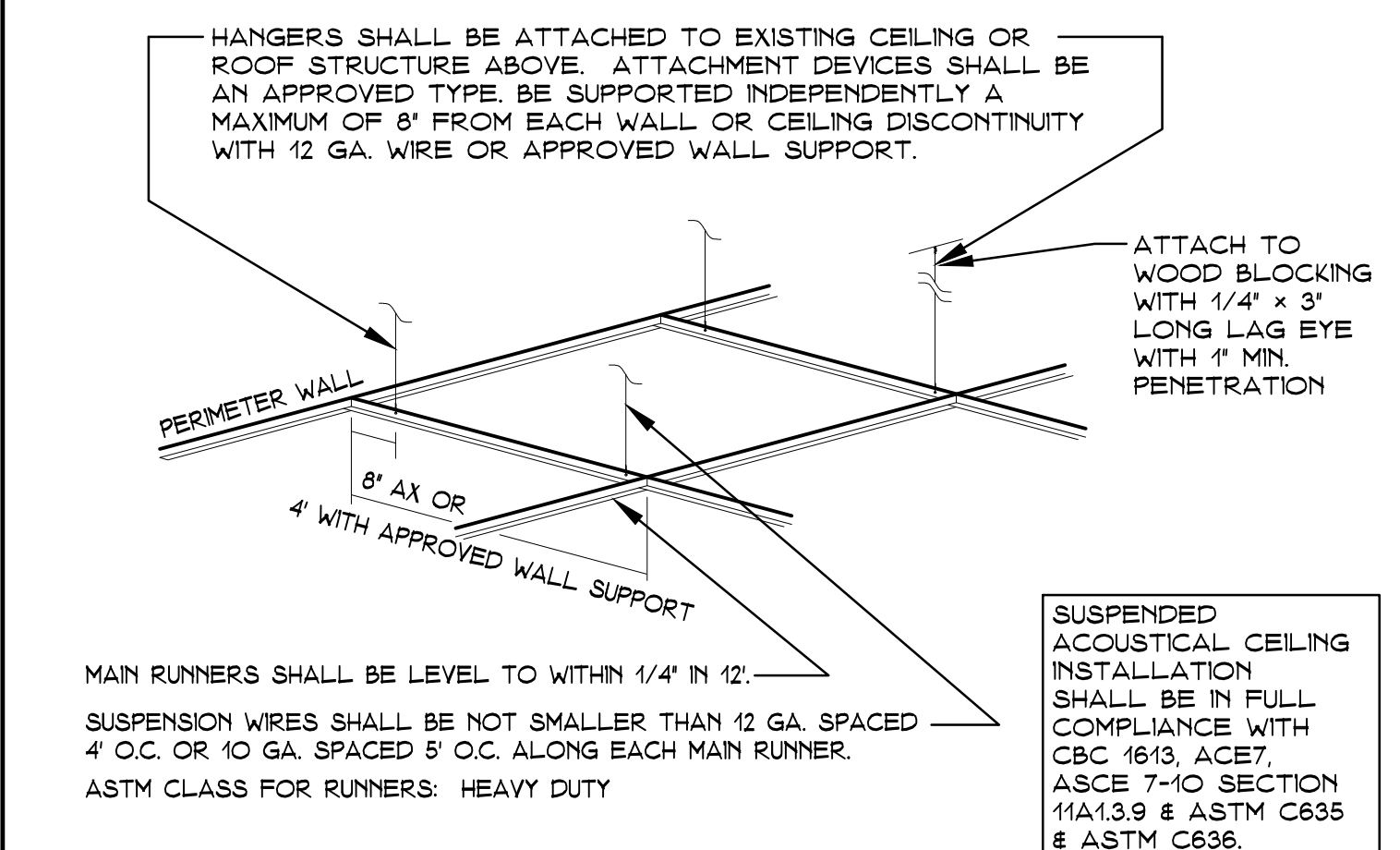

NOTE: ATTACH GRID TO TWO ADJACENT WALLS

SUSPENSION SYSTEM SHALL BE RATED FOR CATEGORY 'D' SEISMIC DESIGN AND SHALL BE OF 'HEAVY-DUTY' TYPE.

3 METAL SUSPENSION SYSTEMS
A4.1 NOT TO SCALE



CONSULTANT INFO:

A TENANT IMPROVEMENT FOR:
YOLO 911 DISPATCH CENTER
35 N. COTTONWOOD ST.
WOODLAND, CA 95695

ISSUE TYPE:

REVISIONS:

DATE: 12-21-23
PROJECT NUMBER: 23-378
DRAWING TITLE: WALL TYPE & CEILING DETAILS
SHEET NUMBER: A4.1

MECHANICAL GENERAL NOTES

- ALL WORK AND MATERIALS SHALL BE PERFORMED AND INSTALLED IN COMPLIANCE WITH THE FOLLOWING CODES AS AMENDED AND ADOPTED BY THE AUTHORITY(ES) HAVING JURISDICTION: 2022 CALIFORNIA ADMINISTRATIVE CODE (CAC), 2022 CALIFORNIA BUILDING CODE (CBC), 2022 CALIFORNIA FIRE CODE (CFC), 2022 CALIFORNIA MECHANICAL CODE (CMC), 2022 CALIFORNIA PLUMBING CODE (CPC), 2022 CALIFORNIA ELECTRICAL CODE (CEC), 2022 CALIFORNIA ENERGY CODE (CENC), 2022 CALIFORNIA GREEN BUILDING CODE (CGC), NATIONAL FIRE PROTECTION ASSOCIATION (NFPA), OCCUPATIONAL SAFETY AND HEALTH ACT (OSHA), AND ANY OTHER LOCAL CODES, ORDINANCES, REGULATIONS, OR AUTHORITIES HAVING JURISDICTION. NOTHING IN THESE PLANS IS TO BE CONSTRUED TO PERMIT WORK NOT CONFORMING TO THESE CODES OR OTHER CODES AND REGULATIONS APPLICABLE TO THIS PROJECT. THESE CODES SHALL DETERMINE MINIMUM REQUIREMENTS FOR MATERIALS, METHODS, AND LABOR PRACTICES NOT OTHERWISE DEFINED IN THESE SPECIFICATIONS.
- CONTRACTOR TO EXAMINE THE PROPOSED WORK SITE AND BECOME FAMILIAR WITH ALL JOB CONDITIONS AFFECTING THE WORK SHOWN. CONTRACTOR(S) SHALL FIELD-VERIFY SITE CONDITIONS INCLUDING LOCATIONS AND SIZES OF EXISTING PIPING, VALVES, CLEANOUTS, WASTE MAINS, GAS METERS, ETC., AND BIDS SHALL BE BASED ON ACTUAL FIELD CONDITIONS. NO ADDITIONAL ALLOWANCE WILL BE GRANTED DUE TO LACK OF KNOWLEDGE OF SITE CONDITIONS. ACCEPT SOLE AND COMPLETE RESPONSIBILITY FOR CONDITIONS OF THE JOBSITE, INCLUDING SAFETY OF ALL PERSONS AND PROPERTY DURING PERFORMANCE OF THE WORK.
- DRAWINGS INDICATE DIAGRAMMATICALLY THE ARRANGEMENT OF PRINCIPAL APPARATUS, PIPING, DUCTWORK, AND OTHER MATERIAL. FOLLOW DRAWING AS CLOSELY AS POSSIBLE IN ORDER TO ACHIEVE A NEAT INSTALLATION WHILE STILL WORKING AROUND ANY OBSTRUCTIONS. INSPECT SITE CONDITIONS AFFECTING THE WORK AND PROVIDE FITTINGS AND ACCESSORIES AS REQUIRED TO MEET CONDITIONS WHETHER SHOWN OR NOT.
- IT IS NOT THE INTENTION OF THE PLANS AND SPECIFICATIONS TO COVER ALL INCIDENTALS REQUIRED TO PROVIDE COMPLETE AND FULLY-OPERATIONAL SYSTEMS. THE CONTRACTOR IS TO FURNISH ALL LABOR, MATERIALS, TRANSPORTATION, EQUIPMENT, MISCELLANEOUS SERVICES, ETC., REQUIRED TO ACCOMPLISH THIS RESULT. ANYTHING WHICH MAY BE REASONABLY CONSTRUED AS A NECESSARY PART OF THE INSTALLATION SHALL BE INCLUDED, WHETHER SPECIFICALLY SHOWN OR MENTIONED OR NOT. ENGINEER WILL PROVIDE INTERPRETATIONS UPON REQUEST.
- DEFINITIONS:
 - WORK: LABOR AND MATERIALS OF THE CONTRACTOR AND/OR SUBCONTRACTOR.
 - FURNISH: OBTAIN, COORDINATE, SUBMIT THE NECESSARY DRAWINGS, DELIVER TO THE JOBSITE IN NEW CONDITION AND GUARANTEE.
 - PROVIDE: FURNISH AND INSTALL.
 - CONNECT: BRING SERVICE TO THE EQUIPMENT AND MAKE FINAL ATTACHMENTS INCLUDING NECESSARY PIPE FITTINGS, DUCTWORK, TRANSITIONS, ETC.
 - CONCEALED: HIDDEN FROM SIGHT IN CHASES, FURRED SPACES, SHAFTS, ABOVE CEILING, EMBEDDED IN CONSTRUCTION, IN CRAWL SPACES, OR BURIED.
 - EXPOSED: NOT INSTALLED UNDERGROUND OR CONCEALED AS DEFINED ABOVE.
 - PERFORMANCE: CONTRACTOR SHALL PERFORM ALL WORK SPECIFIED, INDICATED, AND REQUIRED UNLESS OTHERWISE NOTED, INCLUDING FINAL CONNECTIONS, IN A WORKMANLIKE MANNER USING WORKERS SKILLED AND EXPERIENCED IN THE TRADE. PIPES, FIXTURES, EQUIPMENT, GRILLES, REGISTERS, ETC. TO BE INSTALLED LEVEL, SQUARE, OR CENTERED, ETC. TO GIVE A NEAT APPEARANCE.
 - FULL FUNCTION: PROVIDE ALL MINOR ITEMS NECESSARY FOR A COMPLETE AND FULLY FUNCTIONAL INSTALLATION.
- CONTRACTOR SHALL CONFIRM ALL SITE VOLTAGES BEFORE BIDDING AND ORDERING EQUIPMENT. REIMBURSE ELECTRICAL CONTRACTOR, AT NO CHARGE TO CLIENT, FOR ELECTRICAL CONTRACTOR'S COST INCURRED DUE TO SUBSTITUTION OF MECHANICAL EQUIPMENT HAVING ELECTRICAL REQUIREMENTS DIFFERING FROM SITE CONDITIONS.
- CONTRACTOR SHALL PROVIDE THE OWNER WITH COPIES OF OPERATION, MAINTENANCE, AND PREVENTATIVE MAINTENANCE MANUALS FOR EACH MODEL AND TYPE OF PLUMBING AND MECHANICAL EQUIPMENT.
- CONTRACTOR SHALL PROVIDE EVIDENCE OF LICENSING, BONDING, AND INSURANCE, AND PROVIDE OTHER NECESSARY ADMINISTRATIVE FUNCTIONS FOR CONTRACTOR'S WORK.
- CONTRACTOR SHALL PROCURE AND PAY FOR ALL REQUIRED PERMITS AND SERVICE CHARGES.
- COORDINATION: CONFORM TO GENERAL CONSTRUCTION CONTRACT DOCUMENTS EXCEPT AS MODIFIED HEREIN. REFER ALSO TO STRUCTURAL AND ELECTRICAL CONTRACT DOCUMENTS. COORDINATE ALL WORK WITH OTHER TRADES.
- CUTTING AND PATCHING: CUT AND PATCH AS REQUIRED. CUT OR WELD STRUCTURAL MEMBERS ONLY WITH APPROVAL OF A STRUCTURAL ENGINEER. PATCHING SUBJECT TO ACCEPTANCE BY OWNER.
- SAW CUT TRENCHES IN SLAB SHALL BE FULLY RESTORED AND REINFORCED TO PREVENT SAGGING. ROUGHEN SAW CUT EDGES PRIOR TO RE-POURING CONCRETE.
- COORDINATE ALL WORK WITH OTHER TRADES TO PROVIDE A COMPLETE INSTALLATION. CONNECT ALL EQUIPMENT FURNISHED BY OTHERS AS REQUIRED. INSTALL ALL WORK TO CLEAR ARCHITECTURAL AND STRUCTURAL MEMBERS. INSTALL ALL ABOVE GRADE (OVERHEAD) PIPING AS HIGH AS PRACTICAL.
- RESTORE ALL DAMAGE RESULTING FROM YOUR WORK AND LEAVE PREMISES IN CLEAN CONDITION WHEN FINISHED WITH WORK. ADJUST, CLEAN, REPAIR, OR REPLACE PRODUCTS, WHICH HAVE BEEN DAMAGED.
- GUARANTEE ALL WORK AND MATERIALS FOR ONE YEAR MINIMUM FROM DATE OF FILING NOTICE OF COMPLETION.
- PROVIDE FLASHING AND COUNTER FLASHING FOR ALL WALL AND ROOF PENETRATIONS.
- ADJUSTMENTS: MAKE MINOR ADJUSTMENTS TO WORK WHERE REQUESTED BY OWNER, WHEN SUCH ADJUSTMENTS ARE NECESSARY TO PROPER OPERATION AND WITHIN THE INTENT OF THE CONTRACT.
- MATERIALS AND EQUIPMENT: PROVIDE NEW, UL-LISTED, COMMERCIAL-GRADE MATERIALS, DEVICES, EQUIPMENT, AND FIXTURES SUITABLE FOR THE ENVIRONMENT WHERE INSTALLED. REUSE EXISTING ONLY WHEN COMPLIANT WITH THE CONTRACT DOCUMENTS, IN GOOD CONDITION, AND APPROVED BY THE ENGINEER.
- INSTALLATION: INSTALL ALL MATERIALS, EQUIPMENT, AND SYSTEMS IN FULL ACCORD WITH MANUFACTURER'S INSTRUCTIONS, CLEARANCES, ETC.
- LAYOUT: INSTALL ALL PIPING AND DUCTWORK TO PRESENT A NEAT AND ORDERLY APPEARANCE. RUN ALL LINES PARALLEL WITH BUILDING CONSTRUCTION AS MUCH AS POSSIBLE. MAINTAIN HEADROOM, EQUIPMENT CLEARANCE, AND GRADIENT WHERE REQUIRED. ALLOW FOR EXPANSION & CONTRACTION.
- ACCESS DOORS: PROVIDE ACCESS DOORS OR PANELS FOR ALL VALVES, CLEANOUTS, DAMPERS, CONTROLS, DEVICES, AND OTHER ITEMS REQUIRING INSPECTION OR MAINTENANCE.
- START-UP: THOROUGHLY TEST/DEMONSTRATE PROPER OPERATION OF ALL SYSTEMS AND EQUIPMENT MODIFIED, FURNISHED OR INSTALLED UNDER THIS CONTRACT.
- WARRANTY: ALL MATERIALS AND EQUIPMENT INSTALLED UNDER THIS CONTRACT SHALL BE GUARANTEED FREE FROM ALL MECHANICAL, ELECTRICAL, AND WORKMANSHIP DEFECTS FOR A MINIMUM OF ONE YEAR FROM DATE OF FINAL ACCEPTANCE. CONTRACTOR SHALL BE RESPONSIBLE FOR ALL DAMAGES TO THE PREMISES CAUSED BY LEAKS AND/OR BREAKS IN PIPES AND FIXTURES INSTALLED UNDER THIS CONTRACT, AS WELL AS ANY DAMAGE FROM LEAKS VIA ROOF PENETRATIONS MADE AND SEALED UNDER CONTRACTOR'S SCOPE.
- PATCHING & PAINTING: RESTORE ANY DAMAGE RESULTING FROM THE WORK AND LEAVE PREMISES CLEAN. ADJUST, CLEAN, REPAIR, AND/OR REPLACE ANY ITEMS DAMAGED BY THE WORK. RESTORE WALL AND ROOF PENETRATIONS TO MATCH SURROUNDING WALL OR ROOF, RESPECTIVELY.
- AIR BALANCE: PROVIDE SERVICES NECESSARY TO VERIFY AIR QUANTITIES AND BALANCE FOR ESTABLISHED QUANTITIES AND UNIFORM TEMPERATURE IN THE SPACES SERVED. ADJUST ALL DAMPERS AND ELEMENTS IN GRILLES AND DIFFUSERS FOR PROPER AIR DISTRIBUTION AND TO MINIMIZE DRAFTS. COMPLY WITH SMACNA MANUAL FOR THE BALANCING AND ADJUSTMENT OF AIR DISTRIBUTION SYSTEMS.
- DUCTWORK SHALL BE FABRICATED AND INSTALLED IN ACCORDANCE WITH THE LATEST EDITION OF THE SMACNA LOW PRESSURE DUCT CONSTRUCTION STANDARD.
- MATERIALS EXPOSED WITHIN DUCTS OR PLENUMS SHALL BE NONCOMBUSTIBLE OR SHALL HAVE A FLAME SPREAD INDEX NOT TO EXCEED 25 AND A SMOKE DEVELOPED INDEX NOT TO EXCEED 50, WHERE TESTED AS A COMPOSITE PRODUCT IN ACCORDANCE WITH ASTM E84 OR UL 723
- ALL SUPPLY BRANCH DUCTS SHALL HAVE MANUAL VOLUME BALANCING DAMPERS WITH ACCESSIBLE LOCKING TYPE QUADRANT
- PROVIDE CONICAL FITTINGS FOR ALL ROUND TO RECTANGULAR DUCTWORK CONNECTIONS
- PROVIDE TURNING VANES FOR RECTANGULAR DUCTWORK AT ALL HARD 90 DEGREE ELBOWS
- DUCTWORK SHALL MEET UL 181, CLASS I AND NFPA 90A AND 90B. DUCT SHALL BE INSTALLED STRAIGHT AND SUPPORT SPACING SHALL BE IN STRICT ACCORDANCE WITH SMACNA HVAC DUCT CONSTRUCTION STANDARDS. METAL AND FLEXIBLE, FLEXIBLE DUCTWORK TO BE 5" MAX LENGTH, AND SHALL BE EXTENDED TO THE FULLEST POSSIBLE LENGTH, IN ORDER TO MINIMIZE PRESSURE DROP IN THE DUCT. EXCESS DUCT LENGTHS SHALL BE SHORTENED TO PREVENT UNNECESSARY CHANGES IN DIRECTIONS, WHERE ABRUPT CHANGES IN DIRECTION ARE UNAVOIDABLE USE ADJUSTABLE SHORT RADIUS SHEET METAL ELBOWS TO MAKE DIRECTION CHANGES. CONNECTIONS AT METAL DUCTS OR COLLARS SHALL BE MADE BY DRAW BANDS AND PRESSURE-SENSITIVE TAPE WITH THE DRAW BANDS TIGHTENED AS RECOMMENDED BY THE MANUFACTURER WITH AN ADJUSTABLE TENSIONING TOOL. USING PRESSURE-SENSITIVE TAPE ALONE WITHOUT DRAW BANDS IS NOT ACCEPTABLE. ALL PRESSURE-SENSITIVE TAPES AND MASTICS USED SHALL COMPLY WITH UL 181.
- HVAC EQUIPMENT SHALL NOT BE OPERATED DURING CONSTRUCTION WITHOUT A FILTER INSTALLED TO PROTECT THE EVAPORATOR COIL. AFTER ALL CONSTRUCTION IS COMPLETED, ALL CONSTRUCTION FILTERS SHALL BE REMOVED AND NEW FILTERS SHALL BE INSTALLED.
- HVAC EQUIPMENT SHALL BE CERTIFIED BY THE MANUFACTURER FOR COMPLIANCE WITH CALIFORNIA ENERGY COMMISSION STANDARDS.

GRILLE SCHEDULE								
TAG	TYPE	MANU.	MODEL	MOUNTING LOCATION	FRAME	MODULE SIZE	NECK SIZE	REMARKS
CD-1	CEILING DIFFUSER	TITUS	PCS	CEILING	BORDER TYPE 3	24"x24"	SEE PLANS	LAY IN, PERFORATED STEEL DIFFUSER WITH 4-WAY DEFLECTION
CR-1	CEILING RETURN	TITUS	PAR	CEILING	BORDER TYPE 1	20"x20"	N/A	SURFACE MOUNT, STEEL PERFORATED RETURN GRILLE FOR EXISTING CEILING PLENUM RETURN

RIGID DUCT SCHEDULE			
TYPE	DUCT SIZE (IN.)	MINIMUM THICKNESS (IN.)	GALVANIZED GAUGE NO.
ROUND	≤14	0.0157	28
	16-18	0.0187	26
	≥20	0.0236	24
RECTANGULAR	≤14	0.0157	28
	>14	0.0187	26

EXSITING FAN COIL SCHEDULE									
TAG	MANU.	MODEL	LOCATION	SERVES	NOMINAL TONS	CFM	MIN. OSA	ELECTRICAL	REMARKS
FC-1	TRANE	TWE12043AAA	2ND FLOOR	COMM CENTER 110, OFFICES, BREAKROOM	10.0	3,600	450	V-φ-Hz 208-3-60	EXISTING FAN COIL UNIT WITH ECONOMIZER AND BAROMETRIC RELIEF AND SUPPLY AIR SMOKE DETECTOR

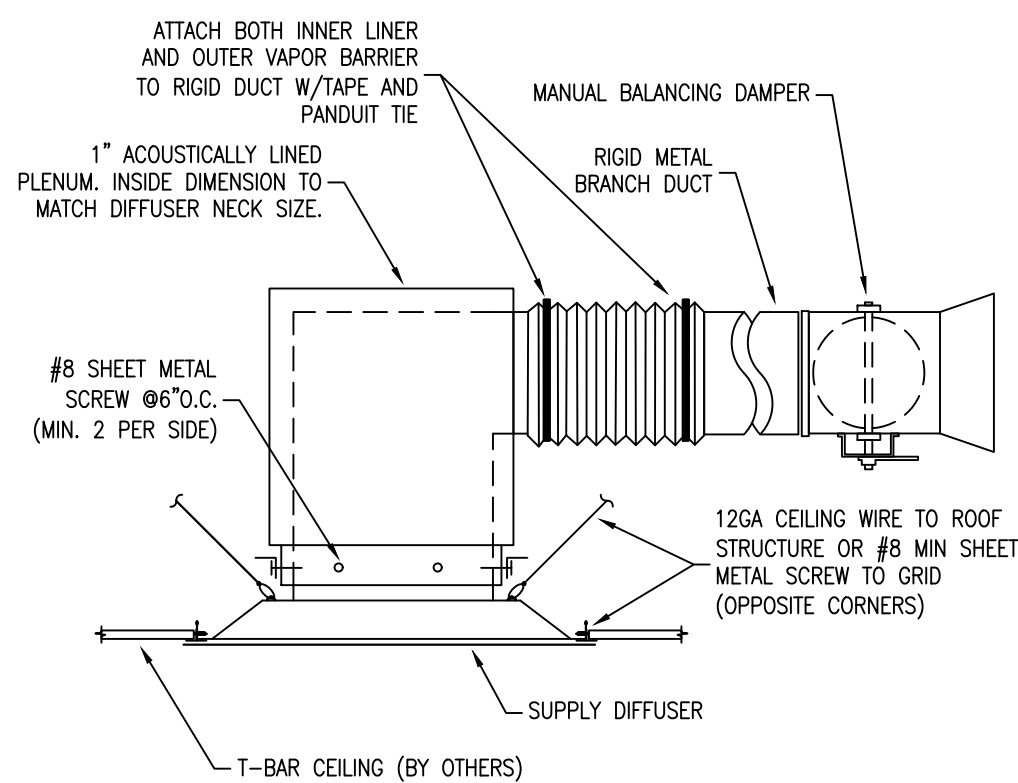

DIFFUSER MOUNTING (T-BAR) 1 MO

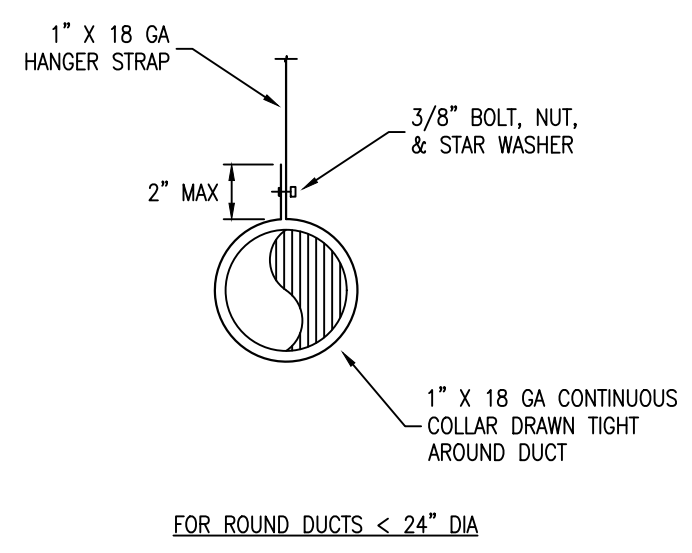

ROUND DUCT SUPPORT 2 MO

MECHANICAL CALGREEN NOTES	
5.504.1	THE PERMANENT HVAC SYSTEM SHALL ONLY BE USED DURING CONSTRUCTION IF NECESSARY TO CONDITION THE BUILDING OR AREAS OF ADDITION OR ALTERATION WITHIN THE REQUIRED TEMPERATURE RANGE FOR MATERIAL AND EQUIPMENT INSTALLATION. IF THE HVAC SYSTEM IS USED DURING CONSTRUCTION, USE RETURN AIR FILTERS WITH A MINIMUM EFFICIENCY REPORTING VALUE (MERV) OF 8, BASED ON ASHRAE 52.2-1999, OR AN AVERAGE EFFICIENCY OF 30 PERCENT BASED ON ASHRAE 52.1-1992. REPLACE ALL FILTERS IMMEDIATELY PRIOR TO OCCUPANCY, OR, IF THE BUILDING IS OCCUPIED DURING ALTERATION, AT THE CONCLUSION OF CONSTRUCTION.
5.504.3	AT THE TIME OF ROUGH INSTALLATION OR DURING STORAGE ON THE CONSTRUCTION SITE AND UNTIL FINAL STARTUP OF THE HEATING AND COOLING EQUIPMENT, ALL DUCT AND OTHER RELATED AIR DISTRIBUTION COMPONENT OPENINGS SHALL BE COVERED WITH TAPE, PLASTIC, SHEET METAL OR OTHER METHODS ACCEPTABLE TO THE ENFORCING AGENCY TO REDUCE THE AMOUNT OF DUST OR DEBRIS WHICH MAY COLLECT IN THE SYSTEM.
5.504.5.3	IN MECHANICALLY VENTILATED BUILDINGS, PROVIDE REGULARLY OCCUPIED AREAS OF THE BUILDING WITH AIR FILTRATION MEDIA FOR OUTSIDE AND RETURN AIR PRIOR TO OCCUPANCY THAT PROVIDES AT LEAST A MERV OF 13.
5.505.1	BUILDINGS SHALL MEET OR EXCEED THE PROVISIONS OF CALIFORNIA BUILDING CODE, CCR, TITLE 24, PART 2, SECTIONS 1202 AND CHAPTER 14.
5.506.1	FOR MECHANICALLY OR NATURALLY VENTILATED SPACES IN BUILDINGS, MEET THE MINIMUM REQUIREMENTS OF SECTION 120.1 OF THE CALIFORNIA ENERGY CODE, CCR, TITLE 24, PART 6 AND CHAPTER 4 OF CCR, TITLE 8 OR THE APPLICABLE LOCAL CODE, WHICHEVER IS MORE STRINGENT.
5.506.2	FOR BUILDINGS EQUIPPED WITH DEMAND CONTROL VENTILATION, CO2 SENSORS AND VENTILATION CONTROLS SHALL BE SPECIFIED AND INSTALLED IN ACCORDANCE WITH THE REQUIREMENTS OF THE LATEST EDITION OF THE CALIFORNIA ENERGY CODE, CCR, TITLE 24, PART 6, SECTION 120.1(C)(4).
5.508.1	INSTALLATIONS OF HVAC, REFRIGERATION AND FIRE SUPPRESSION EQUIPMENT SHALL COMPLY WITH SECTIONS 5.508.1.1 AND 5.508.1.2
5.508.1.1	CHLOROFLUOROCARBONS (CFCs). INSTALL HVAC AND REFRIGERATION EQUIPMENT THAT DOES NOT CONTAIN CFCs.
5.508.1.2	HALONS. INSTALL FIRE SUPPRESSION EQUIPMENT THAT DOES NOT CONTAIN HALONS.
5.410.4.5	PROVIDE THE BUILDING OWNER WITH DETAILED OPERATING AND MAINTENANCE INSTRUCTIONS AND COPIES OF GUARANTIES/WARRANTIES FOR EACH SYSTEM PRIOR TO FINAL INSPECTION.
5.410.4	TESTING AND ADJUSTING OF SYSTEMS SHALL BE REQUIRED FOR BUILDINGS LESS THAN 10,000 SQUARE FEET OR NEW SYSTEMS TO SERVE AN ADDITION OR ALTERATION SUBJECT TO SECTION 303.1.
5.410.4.3.1	BEFORE A NEW SPACE-CONDITIONING SYSTEM SERVING A BUILDING OR SPACE IS OPERATED FOR NORMAL USE, THE SYSTEM SHOULD BE BALANCED IN ACCORDANCE WITH THE PROCEDURES DEFINED BY NATIONAL STANDARDS LISTED IN SECTION 5.410.4.3.1.

MECHANICAL SHEET INDEX

- M0 MECHANICAL SCHEDULES, DETAILS, & GENERAL NOTES
- M1 MECHANICAL PLAN

MECHANICAL SCOPE OF WORK

- INSTALLATION OF NEW GRILLES, DIFFUSERS, DUCTWORK, AND ASSOCIATED COMPONENTS FOR COMM CENTER 110
- BALANCE EXISTING FAN COIL FOR NEW OUTSIDE AIR VENTILATION RATE AND SUPPLY AIRFLOWS LISTED ON THE PLANS

MECHANICAL LEGEND

- POC
- GAS POC
- COLD WATER POC
- CONDENSATE POC
- POWER AND CONTROL WIRING
- SWITCH
- THERMOSTAT
- CO2 SENSOR
- FLEX DUCT
- DAMPER
- DUCT REDUCER
- CEILING DIFFUSER - TBAR
- CEILING DIFFUSER - HARDLID
- SIDE/SPIRAL DIFFUSER/RETURN
- SLOT DIFFUSER/RETURN
- CEILING RETURN - TBAR
- CEILING RETURN - HARDLID
- EXHAUST GRILLE - TBAR
- EXHAUST GRILLE - HARDLID
- CEILING FIRE-SMOKE DAMPER
- FIRE-SMOKE DAMPER
- SUPPLY AIR
- RETURN AIR
- EXHAUST AIR
- DIAMETER
- AIR CONDITIONING
- ON CENTER
- CUBIC FEET PER MINUTE
- FROM ABOVE, TO BELOW
- FROM BELOW, TO ABOVE
- FIRE DAMPER
- FIRE SMOKE DAMPER
- GAUGE
- GALLONS PER MINUTE
- HORSEPOWER
- BRAKE HORSEPOWER
- MAXIMUM / MINIMUM
- NOT TO SCALE
- OUTSIDE AIR
- RETURN AIR
- SUPPLY AIR
- SHEET METAL SCREW
- TYPICAL
- UNLESS OTHERWISE NOTED

DATE	DESCRIPTION	REVISION	JOB NO.	DRAWN	ALN	CHECKED	JRP	ORIGINAL DATE
			24012					02-09-2024

ISSUED FOR PERMIT DATE 03-01-2024

**YOLO 911 DISPATCH CENTER
TENANT IMPROVEMENT**
35 N. COTTONWOOD ST.
WOODLAND, CA 95665

SHEET TITLE
MECHANICAL SCHEDULES, DETAILS, & GEN. NOTES

SHEET NO.
M0

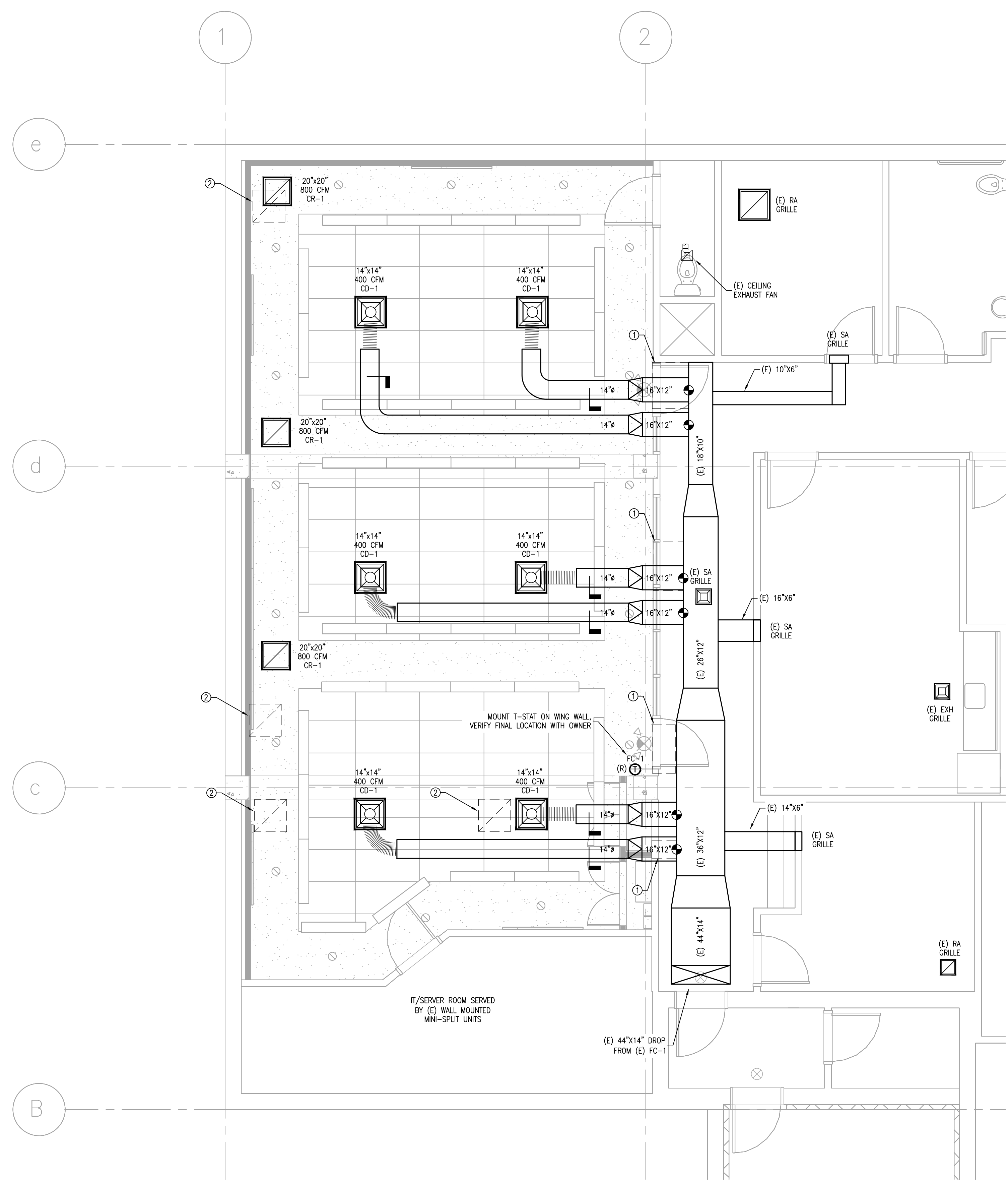

- SHEET NOTES:**
- (E) EXISTING
(N) NEW
(R) RELOCATED
(D) DEMO
 - ALL EQUIPMENT/CONTROLS AND DUCTWORK/FITTINGS SHOWN ARE (N) U.O.N.
 - HVAC EQUIPMENT SHALL BE PERMANENTLY IDENTIFIED AS TO THE AREA OR SPACE SERVED BY THE EQUIPMENT PER CMC 303.6
 - EXISTING UNIT (FC-1) IS INSTALLED WITH AN (E) SMOKE DETECTOR IN THE MAIN SUPPLY AIR DUCT
 - THERMOSTATS TO BE INSTALLED AT 48" A.F.F. (TOP OF THERMOSTAT). DO NOT INSTALL THERMOSTATS OVER CASEWORK OR SHELVING OVER 24" IN DEPTH AND 34" IN HEIGHT. COORDINATE EXACT LOCATION WITH OWNER.
 - CONCEALED DUCTWORK SHALL BE RIGID GALVANIZED METAL PER CMC 603.3 AND 603.4. SEE RIGID DUCTWORK CONSTRUCTION SCHEDULE FOR GAUGE. DUCTWORK SHALL BE INSULATED WITH MINIMUM R=4.2. FLEX DUCT CONNECTORS PER CMC 603.5 SHALL BE PERMITTED FROM RIGID DUCTWORK TO A TERMINAL DEVICE AND SHALL BE <5 FT IN LENGTH PER CMC 603.4.1
 - CONTRACTOR SHALL RECORD THE EXISTING AIRFLOWS OF EACH SUPPLY DIFFUSER ON (E) FC-1 PRIOR TO ANY DEMO WORK. WHEN BALANCING THE NEW SUPPLY DIFFUSERS FOR COMM CENTER 110, ENSURE THE EXISTING SUPPLY DIFFUSERS IN OTHER ROOMS APPROXIMATELY MATCH THEIR RESPECTIVE RECORDED AIRFLOWS

DATE	DESCRIPTION	REVISION	JOB NO.	DRAWN	CHECKED	ORIGINAL DATE
			24012	AJN	JRP	02-09-2024



ISSUED FOR PERMIT DATE 03-01-2024

OPTIMIZEDENERGY
& FACILITIES CONSULTING, INC.
5734 LoneTree Boulevard, Rocklin, CA 95765
Office: (916) 626-5518 www.oefinc.com

- KEY NOTES:**
- ① DEMO (E) SUPPLY DIFFUSER AND ASSOCIATED DUCT, CAP/SEAL OPENINGS
 - ② DEMO (E) RETURN GRILLE

**YOLO 911 DISPATCH CENTER
TENANT IMPROVEMENT**
35 N. COTTONWOOD ST.
WOODLAND, CA 95695

SHEET TITLE
MECHANICAL PLAN

SHEET NO.
M1



ELECTRICAL GENERAL NOTES

- 1) ALL WORK AND MATERIALS SHALL BE PERFORMED AND INSTALLED IN COMPLIANCE WITH THE FOLLOWING CODES AS AMENDED AND ADOPTED BY THE AUTHORITY(ES) HAVING JURISDICTION: 2022 CALIFORNIA ADMINISTRATIVE CODE (CAC), 2022 CALIFORNIA BUILDING CODE (CBC), 2022 CALIFORNIA FIRE CODE (FC), 2022 CALIFORNIA MECHANICAL CODE (CMC), 2022 CALIFORNIA PLUMBING CODE (CPC), 2022 CALIFORNIA ELECTRICAL CODE (CEC), 2022 CALIFORNIA ENERGY CODE (CEC), 2022 CALIFORNIA GREEN BUILDING CODE (CGC), NATIONAL FIRE PROTECTION ASSOCIATION (NFPA), OCCUPATIONAL SAFETY AND HEALTH ACT (OSHA), AND ANY OTHER LOCAL CODES, ORDINANCES, REGULATIONS, OR AUTHORITIES HAVING JURISDICTION. NOTHING IN THESE PLANS IS TO BE CONSTRUED TO PERMIT WORK NOT CONFORMING TO THESE CODES OR OTHER CODES AND REGULATIONS APPLICABLE TO THIS PROJECT. THESE CODES SHALL DETERMINE MINIMUM REQUIREMENTS FOR MATERIALS, METHODS, AND LABOR PRACTICES NOT OTHERWISE DEFINED IN THESE SPECIFICATIONS.
- 2) CEC AND MAXIMUM VOLTAGE DROP OF 5% WILL DEFINE CONDUCTOR SIZING.
- 3) ALL CONDUCTORS SHALL BE IN CONDUITS, U.O.N. CONDUITS SHALL BE USED IN THE FOLLOWING METHODS:
 - POLYVINYL CHLORIDE (PVC) CONDUITS ALLOWED FOR UNDERGROUND OTHERWISE PROVIDE RMC OR IMC. INSTALL PER CEC TABLE 300.5 BURIAL DEPTH REQUIREMENTS
 - ELECTRICAL METALLIC TUBING (EMT) WITH COMPRESSION FITTINGS MAY BE USED IN OR ON WALLS OR CEILING WHERE NOT SUBJECT TO MECHANICAL DAMAGE, DAMP CONDITIONS OR CORROSIIVE CONDITIONS;
 - LIQUID TIGHT FLEXIBLE METAL CONDUIT WHERE REQUIRED;
 - FLEXIBLE METALLIC CONDUIT, WHERE REQUIRED BY CEC, IN DRY LOCATIONS. NOTE: ALL CONDUITS IN HAZARDOUS LOCATIONS (PER CEC) SHALL MEET THE REQUIREMENTS OF CEC CHAPTER 5.
 - CONNECTION TO LIGHT FIXTURES ABOVE LAY-IN CEILING MAY USE 3/8" FLEXIBLE METAL CONDUIT PER CEC 348.20(A)(2)
 - ALL EXPOSED CONDUIT SUBJECT TO WEAR OR COLLISION SHALL BE RIGID GALVANIZED STEEL (RGS) OR INTERMEDIATE METALLIC TUBING (MT). APPLY BITUMASTIC COATING TO ALL METALLIC CONDUITS IN SLABS OR UNDERGROUND.
 - PROVIDE FIRE RETARDANT U.L. APPROVED SEALANT ON ALL RACEWAY PENETRATIONS OF FIRE RATED CEILING, PARTITIONS, WALLS AND STRUCTURAL SLABS.
- 4) FOR TELEPHONE SYSTEM: PROVIDE GROUNDING FOR ALL TELEPHONE BACKBOARDS, TERMINAL CABINETS AND EQUIPMENT PER REQUIREMENTS OF CEC 800 AND TELEPHONE COMPANY.
- 5) ALL EQUIPMENT SHALL BE PROVIDED WITH AN APPROVED DISCONNECTING MEANS PER CEC. ALL DISCONNECT SWITCHES SHALL BE SIZED PER CEC TO ACCOMMODATE EQUIPMENT SERVED, INCLUDING REQUIRED FUSES, U.O.N. SWITCHES SHALL BE HORSE POWER RATED, OF HEAVY DUTY TYPE. PROVIDE MEANS FOR PAD LOCKING IN THE OPEN POSITION.
- 6) ALL CIRCUIT BREAKERS SHALL BE INVERSE TIME (THERMAL MAGNETIC) "PERMANENT TRIP" TYPE. TWO AND THREE POLE CIRCUIT BREAKERS SHALL BE COMMON TRIP.
- 7) ALL CONNECTIONS TO GROUND RODS AND GRID, ETC., SHALL BE MADE WITH U.L. APPROVED WELDED CONNECTIONS, UNLESS NOTED OTHERWISE.
- 8) LIGHTING SYSTEMS SHALL COMPLY WITH CENC. ALL LIGHTING FIXTURES, LAMPS, BALLASTS, DIMMER SWITCHES, AND CONTROLS SHALL BE CERTIFIED WITH THE CALIFORNIA ENERGY COMMISSION AS MEETING ALL CENC REQUIREMENTS AND BE LISTED IN THE APPLICABLE ENERGY COMMISSION DIRECTORY. ALL SUCH DEVICES AND EQUIPMENT SHALL BE INSTALLED PER THE MANUFACTURER'S INSTRUCTIONS. LIGHT FIXTURES IN SUSPENDED CEILING SHALL BE SUPPORTED IN STRICT ACCORDANCE WITH CBC SEISMIC REQUIREMENTS.
- 9) LIGHT POLLUTION REDUCTION: OUTDOOR LIGHTING SYSTEMS SHALL BE INSTALLED TO COMPLY WITH CENC, CGC, OR LOCAL JURISDICTION ORDINANCE, WHICHEVER IS MORE STRINGENT.
- 10) ALL ELECTRICAL EQUIPMENT, DEVICES, WIRE, ETC., SHALL BE LISTED FOR THE INTENDED USE, WITH UNDERWRITER'S LABORATORIES, INC. (UL), WHERE STANDARDS HAVE BEEN ESTABLISHED BY UL. ALL EQUIPMENT SHALL BE RAIN TIGHT WHERE EXPOSED TO THE WEATHER. ALL FLEX CONDUITS CONNECTED TO SUCH EQUIPMENT SHALL BE METALLIC LIQUID TIGHT. ALL EQUIPMENT IN HAZARDOUS LOCATIONS, PER CEC, CHAPTER 5, SHALL BE IN ACCORDANCE WITH THE CEC. ALL EQUIPMENT IN CORROSIVE ENVIRONMENTS SHALL BE IN ENCLOSURES (SUCH AS NEMA 4X) RATED FOR THE ENVIRONMENT.
- 11) RECEPTACLES AND SWITCHES INTENDED TO BE ACCESSIBLE TO THE PUBLIC SHALL BE INSTALLED IN ACCORDANCE WITH CBC 11B-308. INSTALLATION HEIGHT ABOVE FINISHED FLOOR OR GROUND SHALL BE AS FOLLOWS: TOP OF UNOBSTRUCTED OUTLET BOXES SHALL BE NO MORE THAN 48 INCHES, BOTTOM OF UNOBSTRUCTED OUTLET BOXES SHALL BE NO LESS THAN 15 INCHES, ETC.
- 12) UTILITY SERVICE AND REQUIREMENTS SHALL BE COORDINATED WITH POWER SERVICE WITH POWER COMPANY. PROVIDE FOR ALL STANDARD POWER COMPANY REQUIREMENTS. FAULT CURRENT RATINGS SHALL BE PROVIDED BY UTILITY.
- 13) THE LAYOUTS OF THE CONTRACT DRAWINGS ARE DIAGRAMMATIC. IT IS NOT INTENDED TO SHOW EVERY OFFSET AND FITTING, NOR EVERY STRUCTURAL DIFFICULTY THAT WILL BE ENCOUNTERED DURING THE INSTALLATION OF THE WORK. ALIGNMENT OF EQUIPMENT AND ROUTING OF RACEWAYS MAY BE VARIED SLIGHTLY TO ACCOMMODATE ARCHITECTURAL CONDITIONS OR TO AVOID THE WORK OF OTHER TRADES. IF ANY CONFLICTS OCCUR NECESSITATING DEPARTURES FROM CONTRACT DRAWINGS, DETAILS OF DEPARTURES AND REASONS THEREFORE SHALL BE SUBMITTED AS SOON AS PRACTICABLE FOR WRITTEN APPROVAL OF THE ENGINEER.
- 14) THE WORD "CONTRACTOR", AS USED IN THE ELECTRICAL CONTRACT DOCUMENTS, SHALL MEAN THE PRIME (I.E. GENERAL) CONTRACTOR AND THEIR SUBCONTRACTORS FOR THE APPROPRIATE TRADE. WHERE THE OWNER ACTS AS THEIR OWN CONTRACTOR, THE WORD CONTRACTOR APPLIES TO THE OWNER.
- 15) CONTRACTOR SHALL PROVIDE EVIDENCE OF LICENSING, BONDING, AND INSURANCE, AND PROVIDE OTHER NECESSARY ADMINISTRATIVE FUNCTIONS FOR CONTRACTOR'S WORK.
- 16) CONTRACTOR SHALL PROCURE AND PAY FOR ALL REQUIRED PERMITS AND SERVICE CHARGES.
- 17) COORDINATION: CONFORM TO GENERAL CONSTRUCTION CONTRACT DOCUMENTS EXCEPT AS MODIFIED HEREIN. REFER ALSO TO STRUCTURAL AND MECHANICAL CONTRACT DOCUMENTS. COORDINATE ALL WORK WITH OTHER TRADES.
- 18) CUTTING AND PATCHING: ANY CUTTING, ATTACHING, OR WELDING TO BUILDING STRUCTURE SHOULD BE COORDINATED AND APPROVED BY A CALIFORNIA LICENSED STRUCTURAL ENGINEER. PATCHING SUBJECT TO ACCEPTANCE BY OWNER.
- 19) SAW CUT TRENCHES IN SLAB SHALL BE FULLY RESTORED AND REINFORCED TO PREVENT SAGGING. ROUGHEN SAW CUT EDGES PRIOR TO RE-POURING CONCRETE.
- 20) COORDINATE ALL WORK WITH OTHER TRADES TO PROVIDE A COMPLETE INSTALLATION. CONNECT ALL EQUIPMENT FURNISHED BY OTHERS AS REQUIRED. INSTALL ALL WORK TO CLEAR ARCHITECTURAL AND STRUCTURAL MEMBERS. INSTALL ALL ABOVE GRADE (OVERHEAD) PIPING AS HIGH AS PRACTICAL.
- 21) RESTORE ALL DAMAGE RESULTING FROM THE WORK AND LEAVE PREMISES IN CLEAN CONDITION WHEN FINISHED WITH WORK. ADJUST, CLEAN, REPAIR, OR REPLACE PRODUCTS, WHICH HAVE BEEN DAMAGED.
- 22) PROVIDE FLASHING AND COUNTER FLASHING FOR ALL WALL AND ROOF PENETRATIONS.
- 23) WARRANTY: ALL MATERIALS AND EQUIPMENT INSTALLED UNDER THIS CONTRACT SHALL BE GUARANTEED FREE FROM ALL MECHANICAL, ELECTRICAL, AND WORKMANSHIP DEFECTS FOR A MINIMUM OF ONE YEAR FROM DATE OF FINAL ACCEPTANCE. CONTRACTOR SHALL BE RESPONSIBLE FOR ALL DAMAGES TO THE PREMISES CAUSED BY WORK UNDER THIS CONTRACT, AS WELL AS ANY DAMAGE FROM LEAKS VIA ROOF PENETRATIONS MADE AND SEALED UNDER CONTRACTOR'S SCOPE.

ELECTRICAL CALGREEN NOTES

- 5.106.5.3.1 ELECTRIC VEHICLE (EV) CHARGING. CONSTRUCTION SHALL COMPLY WITH CGC SECTION 5.106.5.3.1 OR SECTION 5.106.5.3.2 TO FACILITATE FUTURE INSTALLATION OF ELECTRIC VEHICLE SUPPLY EQUIPMENT (EVSE).
- 5.106.5.3.1 SINGLE CHARGING SPACE REQUIREMENTS. WHEN ONLY A SINGLE CHARGING SPACE IS REQUIRED PER CGC TABLE 5.106.5.3.3, A RACEWAY IS REQUIRED TO BE INSTALLED AT THE TIME OF CONSTRUCTION AND SHALL BE INSTALLED IN ACCORDANCE WITH CEC.
- 5.106.5.3.2 MULTIPLE CHARGING SPACES REQUIREMENTS. WHEN MULTIPLE CHARGING SPACES ARE REQUIRED PER CGC TABLE 5.106.5.3.3, RACEWAY(S) IS/ARE REQUIRED TO BE INSTALLED AT THE TIME OF CONSTRUCTION AND SHALL BE INSTALLED IN ACCORDANCE WITH CEC.
- 5.106.5.3.3 EV CHARGING SPACE CALCULATION. CGC TABLE 5.106.5.3.3 SHALL BE USED TO DETERMINE IF SINGLE OR MULTIPLE CHARGING SPACE REQUIREMENTS APPLY FOR THE FUTURE INSTALLATION OF EVSE.
- 5.106.5.3.4 IDENTIFICATION. THE SERVICE PANEL OR SUBPANEL(S) CIRCUIT DIRECTORY SHALL IDENTIFY THE RESERVED OVERCURRENT PROTECTIVE DEVICE SPACE(S) FOR FUTURE EV CHARGING AS "EV CAPABLE". THE RACEWAY TERMINATION SHALL BE PERMANENTLY AND VISIBLY MARKED AS "EV CAPABLE"
- 5.106.5.3.5 FUTURE CHARGING SPACES. FUTURE CHARGING SPACES QUALIFY AS DESIGNATED PARKING AS DESCRIBED IN CGC SECTION 5.106.5.2 DESIGNATED PARKING FOR CLEAN AIR VEHICLES.

LIGHTING FIXTURE SCHEDULE

TAG	TYPE	MANUF.	SERIES	MODEL	QTY.	MOUNTING	VOLT.	WATTAGE	SOURCE	LUMENS	CCT	REMARKS
A	DOWNLIGHT	LITHONIA	LDN6	LDN6 40/15 LD6 WR LD TRW 120 EZ1	17	RECESSED	120	17.5	LED	1500	4000K	
B	LINEAR INDIRECT	PEERLESS	CERRA	CRW7L LSL 4FT MSL4 R0CR1 40K I500LMF DARK ZT 120 SCT C210	37	SOFFIT SURFACE	120	20.0	LED	2160	4000K	
EMX	EMER/EXIT COMBO	ISOLITE	CMB	CMB-EM-X-U-WH-MTEBP-L1	2	CEILING SURFACE	120	-	LED	-	-	90 MIN BATTERY BACKUP

NOTES: COORDINATE ALL ARCHITECTURAL TRIM AND ACCESSORY OPTIONS WITH OWNER EQUIVALENT FIXTURES ACCEPTABLE CONTINGENT ON OWNER APPROVAL

EXISTING PANEL 'CP' SCHEDULE

Code	VA	Description	BRK	Ckt	PHASE	Ckt	BRK	Description	VA	Code
O	1086	Mod Furniture 1	20/1	1	A	2	20/2	(E)		
O	300	Mod Furniture 1	20/1	3	B	4	-			
O	300	Mod Furniture 2	20/1	5	C	6	20/2	(E)		
O	1086	Mod Furniture 2	20/1	7	A	8	-			
O	1186	(N) Mod Furniture 12 - Supervisor	20/1	9	B	10	20/1	(E) Core Switch Recep	180	R
O	1150	(N) Mod Furniture 12 - Supervisor	20/1	11	C	12	20/2	(E)		
O	1186	Mod Furniture 3	20/1	13	A	14	-			
O	1150	Mod Furniture 3	20/1	15	B	16	20/1	(E)		
O	1186	Mod Furniture 4	20/1	17	C	18	20/1	(E) Firewall Rack	500	R
O	1150	Mod Furniture 4	20/1	19	A	20	20/1	Mod Furniture 6	1186	O
R	1200	(E) BLD MTN Microwave	20/1	21	B	22	20/1	Mod Furniture 6	1150	O
O	1186	Mod Furniture 5	20/1	23	C	24	20/1	Mod Furniture 7	1186	O
R	750	(E) Middle Rack Power	20/1	25	A	26	20/1	Mod Furniture 7	1150	O
R	750	(E) VM Rack Power	20/1	27	B	28	20/1	Mod Furniture 8	1186	O
		(E)	20/1	29	C	30	20/1	Mod Furniture 8	1150	O
R	180	(E) Plug Under Camera Rack	20/1	31	A	32	20/1	Mod Furniture 9	1186	O
R	180	(E) Floor behind Lower Rack	20/1	33	B	34	20/1	Mod Furniture 9	1150	O
O	1150	Mod Furniture 5	20/1	35	C	36	20/1	Mod Furniture 10	1186	O
R	750	(E) Logger Rack Power	20/1	37	A	38	20/1	Mod Furniture 10	1150	O
M	1414	(E) AC-1	30/2	39	B	40	20/1	Mod Furniture 11	1186	O
M	1414	(E) AC-1	-	41	C	42	20/1	Mod Furniture 11	1150	O

Panel Name: CP Bus Rating: 100A
 Voltage & Phase: 120/208Y-3Ø-4W AIC Rating: (E)
 Mounting: Surface Main Type: Circuit Breaker
 Enclosure Rating: NEMA 1 MCB Rating: 100A

Load Code	VA Load per Phase			Calculation	
	A	B	C	Total VA	VA Load
R = Recept	1680	2310	500	4490	1.00 4490
K = Kitchen	0	0	0	0	1.00 0
M = Motor	0	1414.4	1414.4	2828.8	1.00 2829
L = Lighting	0	0	0	0	1.25 0
H = Heat	0	0	0	0	1.25 0
PV = Solar	0	0	0	0	1.25 0
EV = Elec. Vehicle	0	0	0	0	1.25 0
O = Other	9180	7308	9644	26132	1.00 26132
Load Totals	10860	11032.4	11558.4	33450.8	1.00 33450.8
VA of Largest Motor				1414.4	0.25 353.6
Subfeed VA Loads	0.0	0.0	0.0		
Total VA Loads	10860.0	11209.2	11735.2		
Load Balance	96.4%	99.5%	104.1%		
				VA Load This Panel	33804.4
				Amperage This Panel Per Largest Phase VA	97.8

EXISTING ONE-LINE DIAGRAM

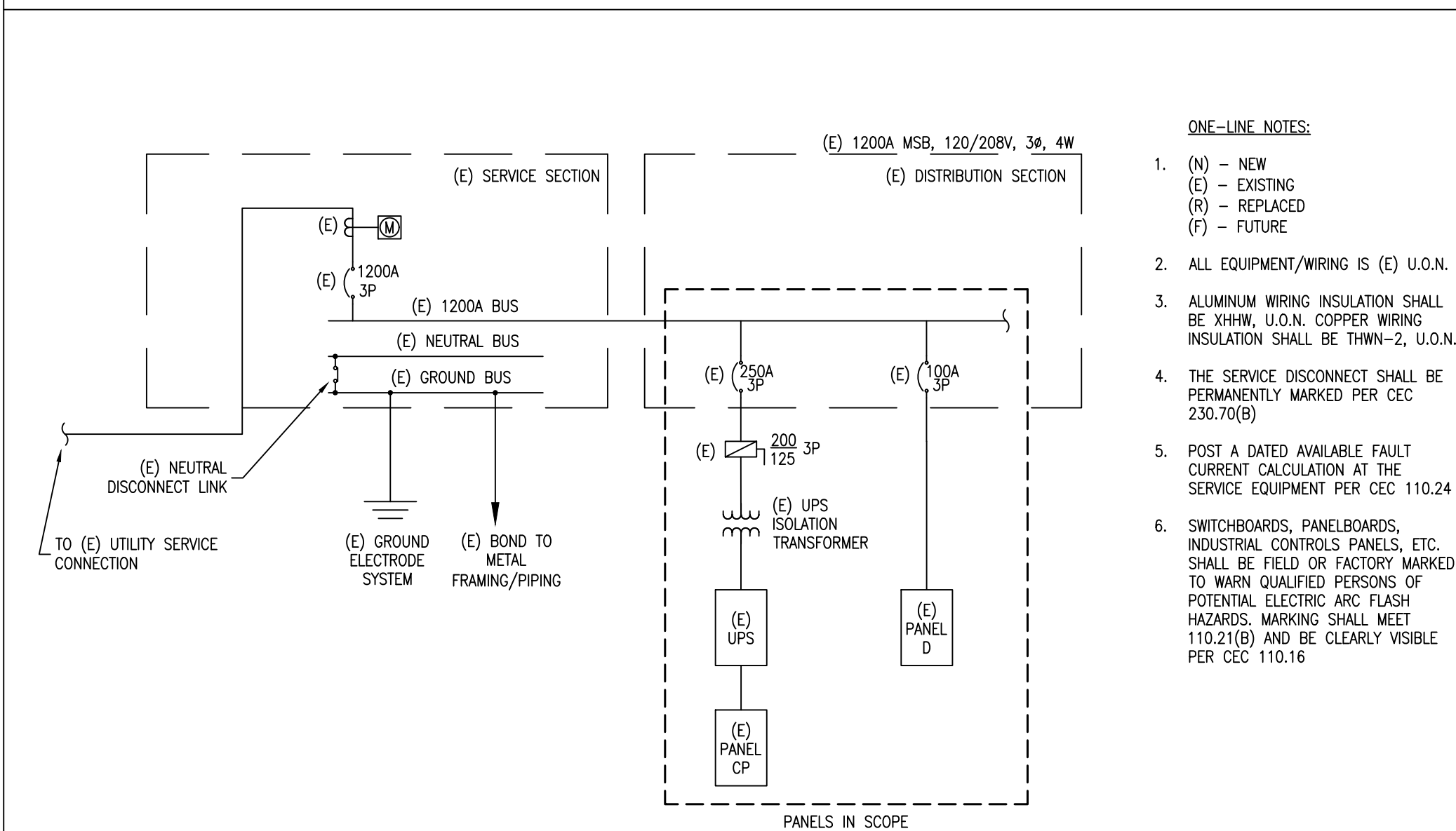

ELECTRICAL SHEET INDEX

- E0 ELECTRICAL SCHEDULES, ONE-LINE, & GENERAL NOTES
- E1 ELECTRICAL PLAN
- E2 INDOOR LIGHTING ENERGY COMPLIANCE

ELECTRICAL SCOPE OF WORK

- 1) REUSE OF EXISTING PANELS AND UPS SYSTEM
- 2) INSTALLATION OF NEW POWER FOR MODULAR FURNITURE IN COMM CENTER 110
- 3) INSTALLATION OF REPLACED LIGHTING AND CONTROLS IN COMM CENTER 110

EXISTING PANEL 'D' SCHEDULE

Code	VA	Description	BRK	Ckt	PHASE	Ckt	BRK	Description	VA	Code
R	540	(E) Recept - Underfloor	20/1	1	A	2	20/1	Mod Furniture 9	984	O
O	984	Mod Furniture 1	20/1	3	B	4	20/1	Mod Furniture 10	984	O
O	984	Mod Furniture 2	20/1	5	C	6	20/1	Mod Furniture 11	984	O
O	984	Mod Furniture 12 (Supervisor)	20/1	7	A	8	20/1	Recept - TV	180	R
O	984	Mod Furniture 3	20/1	9	B	10	20/1	Recept - TV	180	R
O	984	Mod Furniture 4	20/1	11	C	12	20/1	Recept - TV	540	R
R	540	(E) Phone Room	20/1	13	A	14	20/1	Recept - TV	180	R
R	200	(E) Alarm Cab	20/1	15	B	16	20/1	(E) Recept - Phone Room	720	R
R	200	(E) Alarm Cab	20/1	17	C	18	20/1	(E) Recept - Tower Lights	200	R
O	984	Mod Furniture 5	20/1	19	A	20	20/1	Recept - TV	180	R
O	984	Mod Furniture 6	20/1	21	B	22	30/2	(E) Spare		
O	984	Mod Furniture 7	20/1	23	C	24	-			
O	984	Mod Furniture 8	20/1	25	A	26	30/2	(E) Spare		
R	500	(E) NW Electric Gate	20/1	27	B	28	-			
K	800	Refrigerator	20/1	29	C	30				
				31	A	32				
				33	B	34				
				35	C	36				

Panel Name: D Bus Rating: 225A
 Voltage & Phase: 120/208Y-3Ø-4W AIC Rating: (E)
 Mounting: Surface Main Type: Lugs Only
 Enclosure Rating: NEMA 1 Upstream Feed Size: 100A

Load Code	VA Load per Phase			Calculation	
	A	B	C	Total VA	VA Load
R = Recept	1620	1600	940	4160	1.00 4160
K = Kitchen	0	0	800	800	1.00 800
M = Motor	0	0	0	0	1.00 0
L = Lighting	0	0	0	0	1.25 0
H = Heat	0	0	0	0	1.25 0
PV = Solar	0	0	0	0	1.25 0
EV = Elec. Vehicle	0	0	0	0	1.25 0
O = Other	3936	3936	3936	11808	1.00 11808
Load Totals	5556	5536	5676	16768	1.00 16768
VA of Largest Motor				0	0.25 0
Subfeed VA Loads	0.0	0.0	0.0		
Total VA Loads	5556.0	5536.0	5676.0		
Load Balance	99.4%	99.0%	101.6%		
				VA Load This Panel	16768.0
				Amperage This Panel Per Largest Phase VA	47.3

VOLTAGE DROP SUMMARY

Voltage Drop Summary			
Total Feeder Voltage Drop	Worst Case Branch Circuit		Worst Case Voltage Drop
MSB-->CP	0.15%	CP-24	1.37%
MSB-->D	0.52%	D-3	1.23%
			1.52%
			1.75%

ELECTRICAL LEGEND

- 2X4 LIGHT FIXTURE (SURFACE, RECESSED)
- 2X2 LIGHT FIXTURE (SURFACE, RECESSED)
- FIXTURE W/ BATTERY BACKUP (TYP. ALL SHADED FIXTURES)
- RECESSED DOWNLIGHT
- ROUND SURFACE MOUNT LIGHT
- PENDANT LIGHT
- TRACK LIGHT
- SIGNAL LIGHT
- WALL MOUNT LIGHT
- POLE MOUNT LIGHT - 2 HEAD
- POLE MOUNT LIGHT - 1 HEAD
- EXIT/EMERGENCY COMBO LIGHT
- EMERGENCY FIXTURE
- EXIT LIGHT
- CEILING EXHAUST FAN
- WALL MOUNTED SWITCH
- WALL MOUNTED 3-WAY SWITCH
- PHOTOCELL
- PRIMARY AND SECONDARY DAYLIT ZONES
- CEILING MOUNTED SENSOR
- RECEPTACLE - DUPLEX
- RECEPTACLE - QUADRUPLX
- RECEPTACLE - DEDICATED
- RECEPTACLE - 2-POLE
- RECEPTACLE - SPECIALTY, SEE PLANS FOR TYPE
- RECEPTACLE WITH USB PORT
- FLOOR MOUNTED RECEPTACLE
- CEILING MOUNTED RECEPTACLE
- PHONE-DATA PORT
- SMOKE DETECTOR
- CARBON MONOXIDE DETECTOR
- JUNCTION BOX
- DISCONNECT - POLES (CAPACITY/FUSE)
- HOME RUN - PANEL-CIRCUIT(S)
- WIRE/CONDUIT - OVERHEAD
- WIRE/CONDUIT - UNDERGROUND
- POWER PANEL
- TRANSFORMER
- AFF ABOVE FINISHED FLOOR
- +XX" HEIGHT (INCHES) AFF
- D DIMMER
- M OCCUPANCY SENSOR
- V VACANCY SENSOR
- GFCI GROUND FAULT CURRENT INTERRUPTER
- WP WEATHERPROOF
- HP HORSEPOWER
- BHP BRAKE HORSEPOWER
- NTS NOT TO SCALE
- GND GROUND
- GEC GROUNDING ELECTRODE CONDUCTOR
- MSB MAIN SWITCHBOARD
- SBJ SYSTEM BONDING JUMPER
- SSBJ SUPPLY SIDE BONDING JUMPER
- BCPM BRANCH CIRCUIT POWER METER
- TYP TYPICAL
- UN UNLESS OTHERWISE NOTED

DATE	DESCRIPTION	REVISION	JOB NO.	DRAWN	CHECKED	ORIGINAL DATE
			24012	ALN	JRP	02-09-2024

ISSUED FOR	DATE
PERMIT	03-01-2024

OPTIMIZED ENERGY & FACILITIES CONSULTING, INC.
 5734 LoneTree Boulevard, Rocklin, CA 95765
 Office: (916) 626-5518 www.oefinc.com

**YOLO 911 DISPATCH CENTER
 TENANT IMPROVEMENT**
 35 N. COTTONWOOD ST.
 WOODLAND, CA 95669

SHEET TITLE
ELECTRICAL SCHEDULES, ONE-LINE, & GEN. NOTES
 SHEET NO.
E0

SHEET NOTES:

- (E) EXISTING
(N) NEW
(R) RELOCATED
(D) DEMO
- ALL RECEPTACLES/EQUIPMENT LIGHTING/CONTROLS SHOWN ARE (N) U.O.N.
- BRANCH CIRCUITS: ALL WIRING SHALL BE #12 AWG CU AND ALL WIRING INSULATION SHALL BE THWN-2, U.O.N.
- BOTTOM OF BOXES FOR RECEPTACLES AND DATA PORTS SHALL BE AT 16" ABOVE FINISHED FLOOR, U.O.N.
- TOP OF BOXES FOR SWITCHES SHALL BE AT 44" ABOVE FINISHED FLOOR, U.O.N.
- GFCI RECEPTACLES SHALL BE WIRED IN PARALLEL
- ALL LIGHTING CONTROLS, INCLUDING BUT NOT LIMITED TO TIME SWITCHES, PHOTOSENSORS, DIMMERS, AND OCCUPANCY SENSING DEVICES SHALL COMPLY WITH CENC 110.9, 130.0-130.5, 140.6-140.8, AND 141.0. CONTROLS MAY BE SELF-CONTAINED OR PART OF A LIGHTING CONTROL SYSTEM AS DEFINED IN CENC 100.1. RECOMMENDED LIGHTING CONTROL SYSTEMS MEETING THESE REQUIREMENTS INCLUDE ACUTY NULIGHT AND COOPER WAVELINK. CONTROL ELEMENTS SHOWN ON PLANS ARE THE MINIMUM REQUIRED AND SHALL BE INCLUDED IN ANY LIGHTING CONTROL SYSTEM. CONSULT PREFERRED MANUFACTURER FOR PRODUCT SPECIFICATION AND INSTALLATION DETAILS
- ALL NEW LIGHT FIXTURES INSTALLED WITHIN 1/2" OF COMBUSTIBLE MATERIAL SHALL BE RATED FOR AND LABELED AS TYPE IC (INSULATION CONTACT)
- EXIT SIGNS SHALL BE ILLUMINATED AT ALL TIMES. TO ENSURE CONTINUED ILLUMINATION FOR A DURATION OF NOT LESS THAN 90 MINUTES IN CASE OF PRIMARY POWER LOSS, THE SIGN ILLUMINATION MEANS SHALL BE CONNECTED TO AN EMERGENCY POWER SYSTEM PROVIDED FROM STORAGE BATTERIES, UNIT EQUIPMENT OR AN ON-SITE GENERATOR. CONNECT ALL EMERGENCY/EXIT LIGHT FIXTURES TO NEAREST UNSWITCHED HOT LEG LIGHTING CIRCUIT
- SEE XYBIX DRAWINGS FOR CONDUIT POWER AND DATA HOLE LOCATIONS. ENSURE PENETRATIONS DO NOT CONFLICT WITH FLOOR GRID AND VERIFY ALL FINAL HOLE LOCATIONS WITH OWNER. CONDUIT STUBS SHOULD TERMINATE IN XYBIX WORKSTATION CABINET

KEY NOTES:

- PROVIDE (2) 3" CONDUIT STUBS FROM BELOW THE RAISED FLOOR FOR POWER AND DATA TO NEW WORKSTATION. PROVIDE 5' WHIP ON POWER WIRING FOR EACH CIRCUIT. AFTER INSTALLATION OF FURNITURE, CONTRACTOR TO CONNECT ELECTRICAL BOX TO BUILDING POWER. COORDINATE EXACT DETAILS WITH MANUFACTURER DRAWINGS AND INSTALLATION REQUIREMENTS
- CONTRACTOR TO VERIFY EXISTING CIRCUIT SERVING REMOVED WORKSTATION AND TO EXTEND CONDUIT AND WIRING TO NEW LOCATION
- CONTRACTOR TO INSTALL NEW CONDUIT AND WIRING FROM UPS PANEL CP TO WORKSTATION. FIELD VERIFY CONDUIT ROUTING BELOW THE RAISED FLOOR.
- CONTRACTOR TO INSTALL NEW CONDUIT AND WIRING FROM BUILDING PANEL D TO WORKSTATION. FIELD VERIFY CONDUIT ROUTING BELOW THE RAISED FLOOR.
- CONNECT MODULAR FURNITURE GROUNDING BAR TO THE EGC. ENSURE GROUND CONNECTION TO FURNITURE IS PER MANUFACTURER'S REQUIREMENTS
- LIGHTING TO BE RE-CONNECTED TO EXISTING LIGHTING CIRCUIT SERVING COMM ROOM. OVERALL REDUCTION IN LIGHTING WATTAGE
- TV RECEPTACLE AND DATA PORT TO BE MOUNTED AT 84" AFF. CONTRACTOR TO VERIFY MOUNTING HEIGHT AND RECEPTACLE LOCATION WITH OWNER PRIOR TO INSTALLATION

DATE	DESCRIPTION	REVISION	JOB NO.	DRAWN	CHECKED	ORIGINAL DATE
			24012	AJN	JRP	02-09-2024



ISSUED FOR PERMIT DATE 03-01-2024



**YOLO 911 DISPATCH CENTER
TENANT IMPROVEMENT**
35 N. COTTONWOOD ST.
WOODLAND, CA 95695

SHEET TITLE
ELECTRICAL PLAN
SHEET NO.
E1

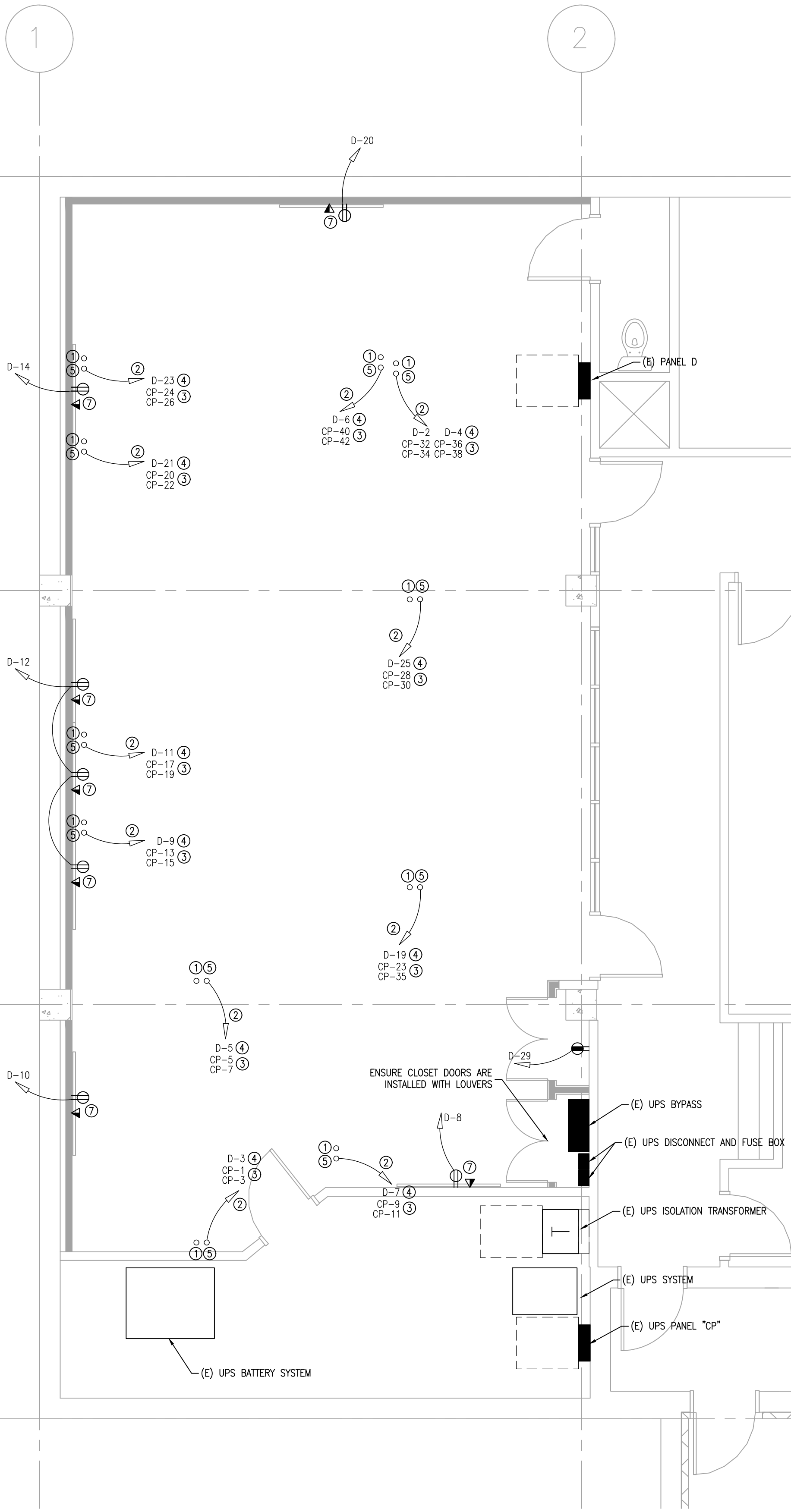

A ELECTRICAL PLAN - POWER
SCALE: 1/4"=1'-0"

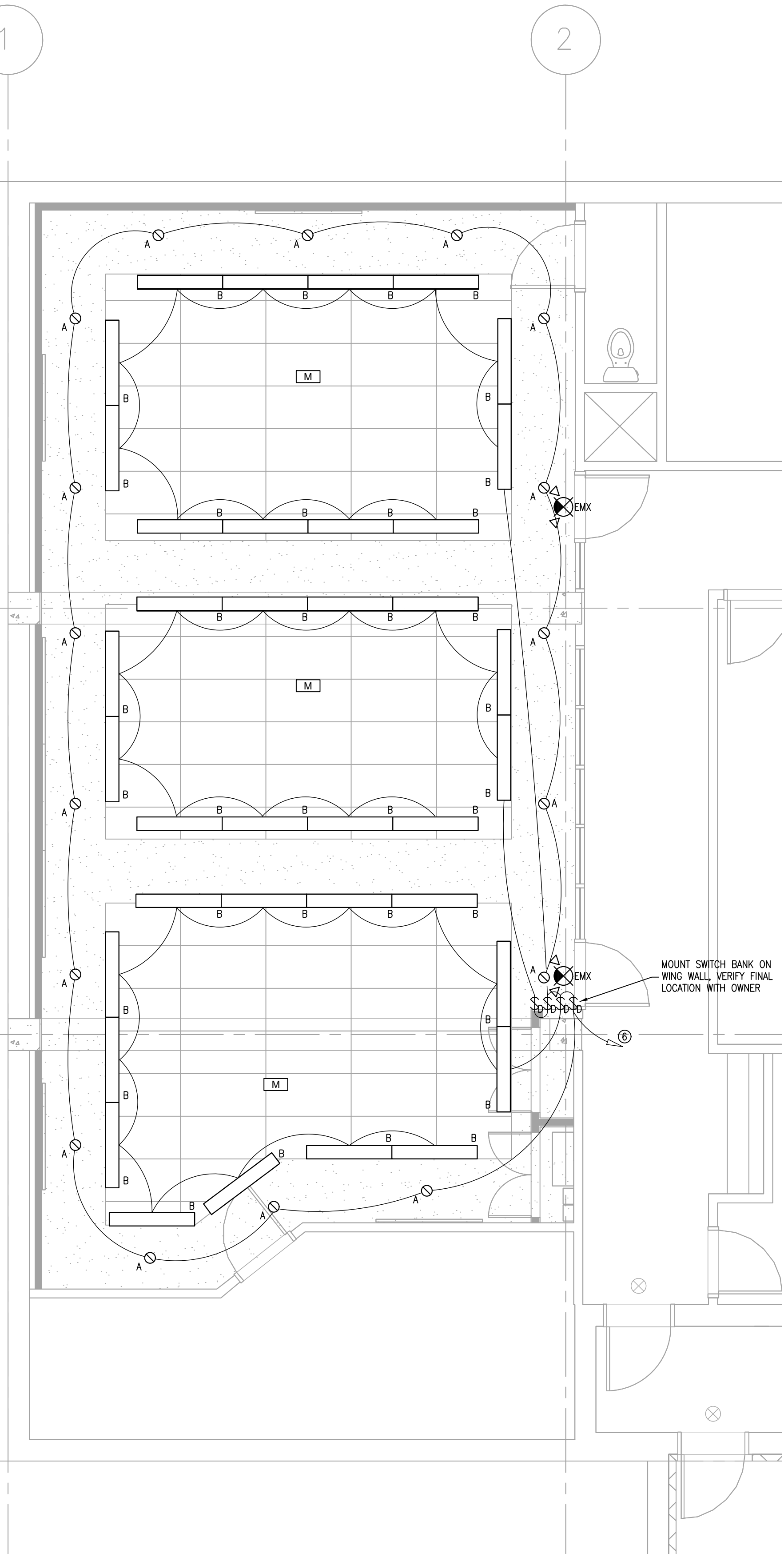

B ELECTRICAL PLAN - LIGHTING
SCALE: 1/4"=1'-0"

STATE OF CALIFORNIA
Indoor Lighting
 CALIFORNIA ENERGY COMMISSION

CERTIFICATE OF COMPLIANCE NRCC-LTI-4
 Project Name: Yolo County YECA Bldg Report Page: (Page 1 of 7)
 Project Address: 35 N. Cottonwood St Date Prepared: 3/1/2024

A. GENERAL INFORMATION

01 Project Location (city)	Woodland	04 Total Conditioned Floor Area (ft ²)	1,250
02 Climate Zone	12	05 Total Unconditioned Floor Area (ft ²)	0
03 Occupancy Types Within Project (select all that apply):		06 # of Stories (Habitable Above Grade)	1

* Commercial Industrial

B. PROJECT SCOPE

This table includes any lighting systems that are within the scope of the permit application and are demonstrating compliance using the prescriptive path outlined in 140.6 / 170.2(e) or 141.0(b) / 180.2(b) for alterations.

Scope of Work	Conditioned Spaces	Unconditioned Spaces
01	02	03
My Project Consists of (check all that apply):	Calculation Method	Area (ft ²)
<input type="checkbox"/> New Lighting System		
<input type="checkbox"/> New Lighting System - Parking Garage		
<input checked="" type="checkbox"/> Altered Lighting System	Area Category Method	1250
	Area Category Method	0
Total Area of Work (ft²)		0

Generated Date/Time: Documentation Software: EnergyPro
 CA Building Energy Efficiency Standards - 2022 Nonresidential Compliance Report Version: 2022.0.000 Compliance ID: EnergyPro-5910-0324-1820
 Schema Version: rev 20220101 Report Generated: 2024-03-01 09:22:20

STATE OF CALIFORNIA
Indoor Lighting
 CALIFORNIA ENERGY COMMISSION

CERTIFICATE OF COMPLIANCE NRCC-LTI-4
 Project Name: Yolo County YECA Bldg Report Page: (Page 4 of 7)
 Project Address: 35 N. Cottonwood St Date Prepared: 3/1/2024

H. INDOOR LIGHTING CONTROLS (Not including PAFs)

Area Level Controls

04	05	06	07	08	09	10	11	12
Area Description	Complete Building or Area Category Primary Function Area	Manual Area Controls 130.1(a) / 160.5(b)4A	Multi-Level Controls 130.1(b) / 160.5(b)4B	Shut-Off Controls 130.1(c) // 160.5(b)4C	Primary/Skylight Daylighting 130.1(d) / 160.5(b)4D	Secondary Daylighting Systems 140.6(a) / 170.2(e)2A	Interlocked Systems 140.6(a) / 170.2(e)2A	Field Inspector
Comm Center	General Commercial Industrial Work Area Precision	Readily Accessible	Dimmer	Occupancy Sensor	NA; Rem < 24sf Glazing	NA; Rem < 24sf Glazing	No	Pass <input type="checkbox"/> Fail <input type="checkbox"/>

13
 Plan Sheet Showing Daylit Zones:

LIGHTING POWER ALLOWANCE: COMPLETE BUILDING OR AREA CATEGORY METHODS

Each area complying using the Complete Building or Area Category Methods per 140.6(b) are included in this table. Column 06 indicates if additional lighting power allowances per 140.6(c) or adjustments per 140.6(a) are being used.

Conditioned Spaces	01	02	03	04	05	06
Area Description	Complete Building or Area Category Primary Function Area	Area Category Primary Function Area	Allowed Density (W/ft ²)	Area (ft ²)	Allowed Wattage (Watts)	Additional Allowance / Adjustment Area Category PAF
Comm Center	General Commercial Industrial Work Area Precision		0.85	1,250	1,062.5	No No
TOTALS:			1,250	1,250	1,062.5	See Tables J, or P for detail

J. ADDITIONAL ALLOWANCE: AREA CATEGORY METHOD QUALIFYING LIGHTING SYSTEM
 This section does not apply to this project.

Generated Date/Time: Documentation Software: EnergyPro
 CA Building Energy Efficiency Standards - 2022 Nonresidential Compliance Report Version: 2022.0.000 Compliance ID: EnergyPro-5910-0324-1820
 Schema Version: rev 20220101 Report Generated: 2024-03-01 09:22:20

STATE OF CALIFORNIA
Indoor Lighting
 CALIFORNIA ENERGY COMMISSION

CERTIFICATE OF COMPLIANCE NRCC-LTI-4
 Project Name: Yolo County YECA Bldg Report Page: (Page 7 of 7)
 Project Address: 35 N. Cottonwood St Date Prepared: 3/1/2024

DOCUMENTATION AUTHOR'S DECLARATION STATEMENT
 I certify that this Certificate of Compliance documentation is accurate and complete.

Documentation Author Name: Alex Batista
 Signature: [Signature]
 Date: 2024-03-01
 Address: 5734 Lonetree Blvd
 City/State/Zip: Rocklin CA 95765
 Phone: (916) 626-5518

- RESPONSIBLE PERSON'S DECLARATION STATEMENT**
 I certify the following under penalty of perjury under the laws of the State of California:
- The information provided on this Certificate of Compliance is true and correct.
 - I am eligible under Division 3 of the Business and Professions Code to accept responsibility for the building design or system design identified on this Certificate of Compliance (responsible designer).
 - The energy features and performance specifications, materials, components, and manufactured devices for the building design or system design identified on this Certificate of Compliance conform to the requirements of Title 24, Part 1 and Part 6 of the California Code of Regulations.
 - The building design features or system design features identified on this Certificate of Compliance are consistent with the information provided on other applicable compliance documents, worksheets, calculations, plans and specifications submitted to the enforcement agency for approval with this building permit application.
 - I will ensure that a completed signed copy of this Certificate of Compliance shall be made available with the building permit(s) issued for the building, and made available to the enforcement agency for all applicable inspections. I understand that a completed signed copy of this Certificate of Compliance is required to be included with the documentation the building owner to the building permit application.

Responsible Designer Name: Alex Batista
 Signature: [Signature]
 Date Signed: 2024-03-01
 License: C23735
 Address: 5734 Lonetree Blvd
 City/State/Zip: Rocklin CA 95765
 Phone: (916) 626-5518

Generated Date/Time: Documentation Software: EnergyPro
 CA Building Energy Efficiency Standards - 2022 Nonresidential Compliance Report Version: 2022.0.000 Compliance ID: EnergyPro-5910-0324-1820
 Schema Version: rev 20220101 Report Generated: 2024-03-01 09:22:20

STATE OF CALIFORNIA
Indoor Lighting
 CALIFORNIA ENERGY COMMISSION

CERTIFICATE OF COMPLIANCE NRCC-LTI-4
 Project Name: Yolo County YECA Bldg Report Page: (Page 2 of 7)
 Project Address: 35 N. Cottonwood St Date Prepared: 3/1/2024

C. COMPLIANCE RESULTS

If any cell on this table says "DOES NOT COMPLY" or "COMPLIES with Exceptional Conditions" refer to Table D. for guidance.

Lighting in conditioned and unconditioned spaces must not be combined for compliance per 140.6(b)1 / 170.2(e)	Allowed Lighting Power per 140.6(b) / 170.2(e) (Watts)					Adjusted Lighting Power per 140.6(a) / 170.2(e) (Watts)			Compliance Results
	01	02	03	04	05	06	07	08	
Complete Building 140.6(c)1	Area Category 140.6(c)2 / 170.2(e)4	Area Category Additional 140.6(c)2G / 170.2(e)4Av (+)	Tailored 140.6(c)3 / 170.2(e)4B (+)	=	Total Allowed (Watts)	Total Designed (Watts)	PAF Lighting Control Credits 140.6(a)2 / 170.2(e)1B (-)	Total Adjusted (Watts) * Includes Adjustments	05 must be >= 08 140.6 / 170.2(e)
(See Table I)	(See Table I)	(See Table J)	(See Table K)	=	1,062.5	1,038	0	1038	COMPLIES
Unconditioned				=	2				COMPLIES

Controls Compliance (See Table H for Details)
 Rated Power Reduction Compliance (See Table Q for Details)

D. EXCEPTIONAL CONDITIONS
 This table is auto-filled with uneditable comments because of selections made or data entered in tables throughout the form.

E. ADDITIONAL REMARKS
 This table includes remarks made by the permit applicant to the Authority Having Jurisdiction.

Generated Date/Time: Documentation Software: EnergyPro
 CA Building Energy Efficiency Standards - 2022 Nonresidential Compliance Report Version: 2022.0.000 Compliance ID: EnergyPro-5910-0324-1820
 Schema Version: rev 20220101 Report Generated: 2024-03-01 09:22:20

STATE OF CALIFORNIA
Indoor Lighting
 CALIFORNIA ENERGY COMMISSION

CERTIFICATE OF COMPLIANCE NRCC-LTI-4
 Project Name: Yolo County YECA Bldg Report Page: (Page 5 of 7)
 Project Address: 35 N. Cottonwood St Date Prepared: 3/1/2024

K. TAILORED METHOD GENERAL LIGHTING POWER ALLOWANCE
 This section does not apply to this project.

L. ADDITIONAL LIGHTING ALLOWANCE: TAILORED WALL DISPLAY
 This section does not apply to this project.

M. ADDITIONAL LIGHTING ALLOWANCE: TAILORED FLOOR AND TASK LIGHTING
 This section does not apply to this project.

N. ADDITIONAL LIGHTING ALLOWANCE: TAILORED DECORATIVE / SPECIAL EFFECTS
 This section does not apply to this project.

O. ADDITIONAL LIGHTING ALLOWANCE: TAILORED VERY VALUABLE MERCHANDISE
 This section does not apply to this project.

P. POWER ADJUSTMENT: LIGHTING CONTROL CREDIT (POWER ADJUSTMENT FACTOR (PAF))
 This section does not apply to this project.

Q. RATED POWER REDUCTION COMPLIANCE FOR ONE-FOR-ONE ALTERATIONS
 This section does not apply to this project.

R. 80% LIGHTING POWER FOR ALL ALTERATIONS - CONTROLS EXCEPTIONS
 This section does not apply to this project.

Generated Date/Time: Documentation Software: EnergyPro
 CA Building Energy Efficiency Standards - 2022 Nonresidential Compliance Report Version: 2022.0.000 Compliance ID: EnergyPro-5910-0324-1820
 Schema Version: rev 20220101 Report Generated: 2024-03-01 09:22:20

STATE OF CALIFORNIA
Indoor Lighting
 CALIFORNIA ENERGY COMMISSION

CERTIFICATE OF COMPLIANCE NRCC-LTI-4
 Project Name: Yolo County YECA Bldg Report Page: (Page 3 of 7)
 Project Address: 35 N. Cottonwood St Date Prepared: 3/1/2024

F. INDOOR LIGHTING FIXTURE SCHEDULE

This table includes all planned permanent and portable lighting other than dwelling unit/ hotel/ motel room lighting. Multifamily dwelling unit and hotel/motel room lighting is documented in Table T. If using Table T to document lighting in multifamily common use areas providing shared provisions for living, eating, cooking or sanitation, those luminaires are not included here.

Designated Wattage: Conditioned Spaces

01	02	03	04	05	06	07	08	09	10
Name or Item Tag	Complete Luminaire Description	Modular (Track) Fixture	Small Aperture & Color Change	Watts per luminaire ²	How is Wattage determined	Total Number of Luminaires	Excluded per 140.6(a)3 / 170.2(e)2C	Design Watts	Field Inspector
A	A	No	NA	17.5	Mfr. Spec	17	No	297.5	Pass <input type="checkbox"/> Fail <input type="checkbox"/>
B	B	No	NA	20	Mfr. Spec	37	No	740	Pass <input type="checkbox"/> Fail <input type="checkbox"/>
Total Designed Watts: CONDITIONED SPACES								1,038	

¹FOOTNOTE: Design Watts for small aperture and color changing luminaires which qualify per 140.6(a)4B / 170.2(e)2D is adjusted to be 75% / 80% of their rated wattage. Table F automatically makes this adjustment, the permit applicant should enter full rated wattage in column 05.
²Authority Having Jurisdiction may ask for Luminaire cut sheets to confirm wattage used for compliance per 130.0(c) / 160.5(b). Wattage used must be the maximum rated for the luminaire, not the lamp.

G. MODULAR LIGHTING SYSTEMS
 This section does not apply to this project.

H. INDOOR LIGHTING CONTROLS (Not including PAFs)

This table includes lighting controls for conditioned and unconditioned spaces.

Building Level Controls	01	02	03
Mandatory Demand Response 110.12(c)		Shut-off controls 130.1(c) / 160.5(b)4C	Field Inspector
NA < 4,000W subject to multilevel		See Area/Space Level Controls	Pass <input type="checkbox"/> Fail <input type="checkbox"/>

Generated Date/Time: Documentation Software: EnergyPro
 CA Building Energy Efficiency Standards - 2022 Nonresidential Compliance Report Version: 2022.0.000 Compliance ID: EnergyPro-5910-0324-1820
 Schema Version: rev 20220101 Report Generated: 2024-03-01 09:22:20

STATE OF CALIFORNIA
Indoor Lighting
 CALIFORNIA ENERGY COMMISSION

CERTIFICATE OF COMPLIANCE NRCC-LTI-4
 Project Name: Yolo County YECA Bldg Report Page: (Page 6 of 7)
 Project Address: 35 N. Cottonwood St Date Prepared: 3/1/2024

S. DAYLIGHT DESIGN POWER ADJUSTMENT FACTOR (PAF)
 This section does not apply to this project.

T. DWELLING UNIT LIGHTING
 This section does not apply to this project.

U. DECLARATION OF REQUIRED CERTIFICATES OF INSTALLATION
 Selections have been made based on information provided in this document. If any selections have been changed by permit applicant, an explanation should be included in Table E. Additional Remarks. These documents must be provided to the building inspector during construction and any with "4" in the form name must be completed through an Acceptance Test Technician Certification Provider (ATTCP). For more information visit: <http://www.energy.ca.gov/title24/attcp/providers.html>

Form/Title
 NRCA-LTI-E - Must be submitted for all buildings.

V. DECLARATION OF REQUIRED CERTIFICATES OF ACCEPTANCE
 Selections have been made based on information provided in this document. If any selections have been changed by the permit applicant, an explanation should be included in Table E. Additional Remarks. These documents must be provided to the building inspector during construction and any with "4" in the form name must be completed through an Acceptance Test Technician Certification Provider (ATTCP). For more information visit: <http://www.energy.ca.gov/title24/attcp/providers.html>

Form/Title
 NRCA-LTI-Q2-A - Must be submitted for occupancy sensors and automatic time switch controls.
 Systems/Spaces To Be Field Verified
 Comm Center;

Generated Date/Time: Documentation Software: EnergyPro
 CA Building Energy Efficiency Standards - 2022 Nonresidential Compliance Report Version: 2022.0.000 Compliance ID: EnergyPro-5910-0324-1820
 Schema Version: rev 20220101 Report Generated: 2024-03-01 09:22:20

DATE	DESCRIPTION	REVISION
24012		



ISSUED FOR: PERMIT DATE: 03-01-2024



**YOLO 911 DISPATCH CENTER
 TENANT IMPROVEMENT
 35 N. COTTONWOOD ST.
 WOODLAND, CA 95665**

SHEET TITLE: INDOOR LIGHTING ENERGY COMPLIANCE

SHEET NO.: E2

PAGE #	PAGE NAME
D2.0	FLOOR PLAN
D3.0	TYPICALS
D6.0	FINISH SELECTION
D7.0	CABLE SHEET
D7.1	CABLE SHEET
D8.0	HOLE LOCATION PLAN
D11.0	CARPET PLAN

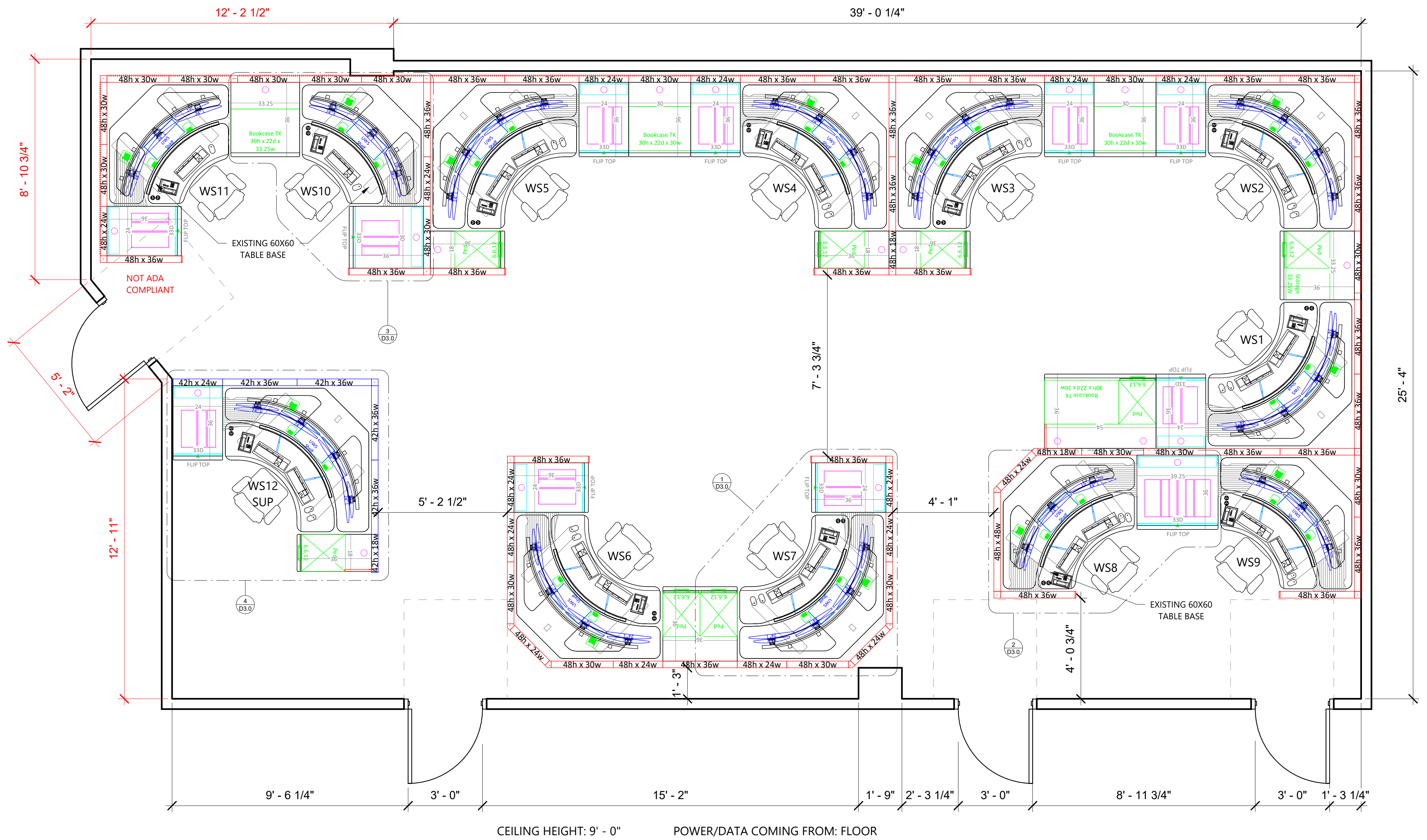
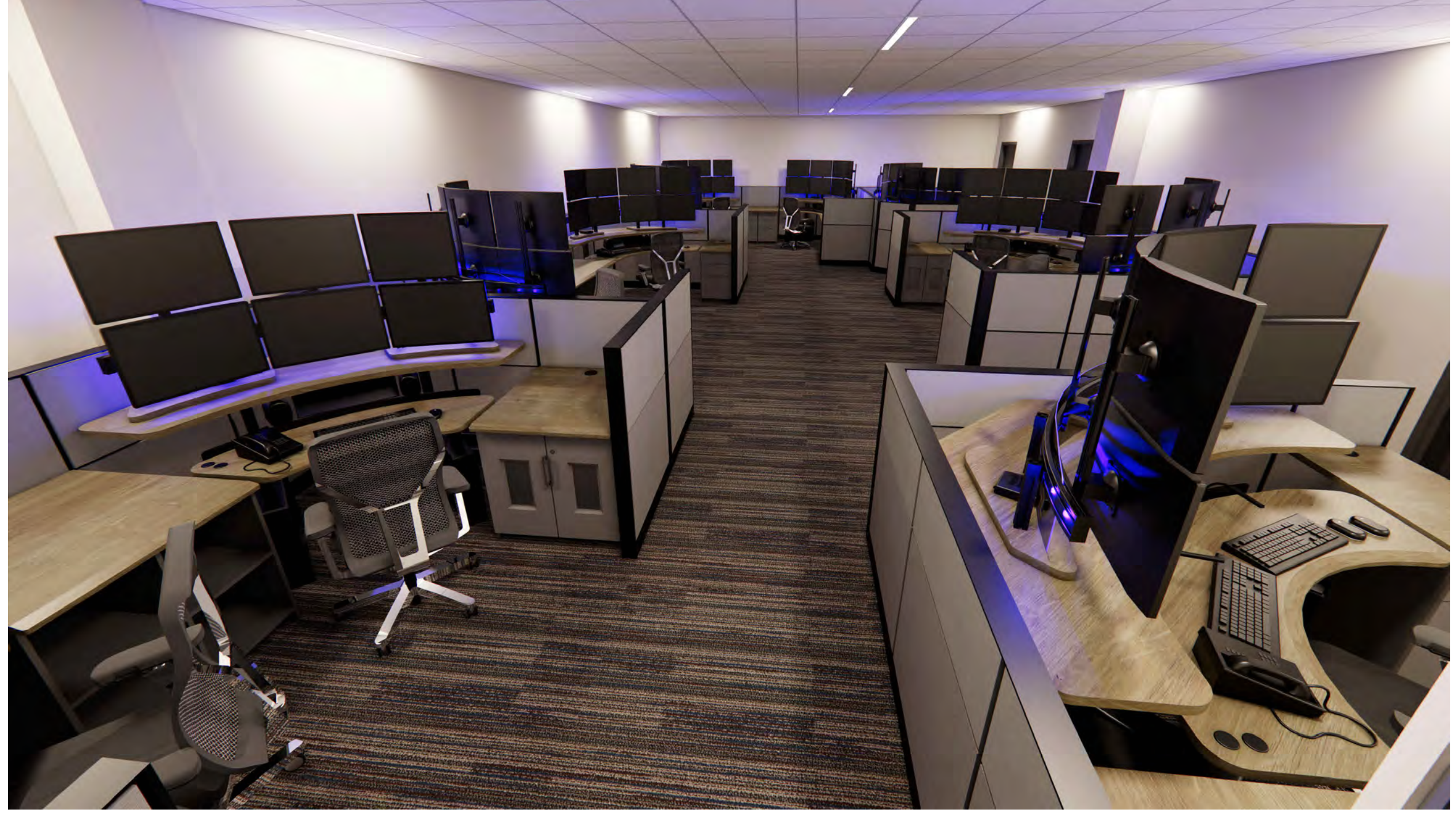

1 FLOOR PLAN
 3/8" = 1'-0"

Opportunity: 0025551
 Carpet Opp: 0027383
 Drawing Name: FLOOR PLAN

SHEET:	SCALE:
D2.0	As indicated

NOTE: This design & layout is the property of XYBIX Systems, Inc. & is not to be used in any written manner without express written permission by XYBIX Systems, Inc.

Sign-Off Initials:	REV
x	14

REV	DESIGNER	DATE	DESCRIPTION
10	Kmr	08.14.23	Update Finishes & Cables
11	Kmr	08.30.23	Update Carpet Finish / Update Layout - (3) OPTIONS
12	Kmr	10.09.23	Option 2 Selected
13	Kmr	11.07.23	Remove Footwell Lighting
14	Kmr	11.29.23	Reduce Worksurface between WS1 & 2 to allow proper ADA Clearance at WS 8 & 9

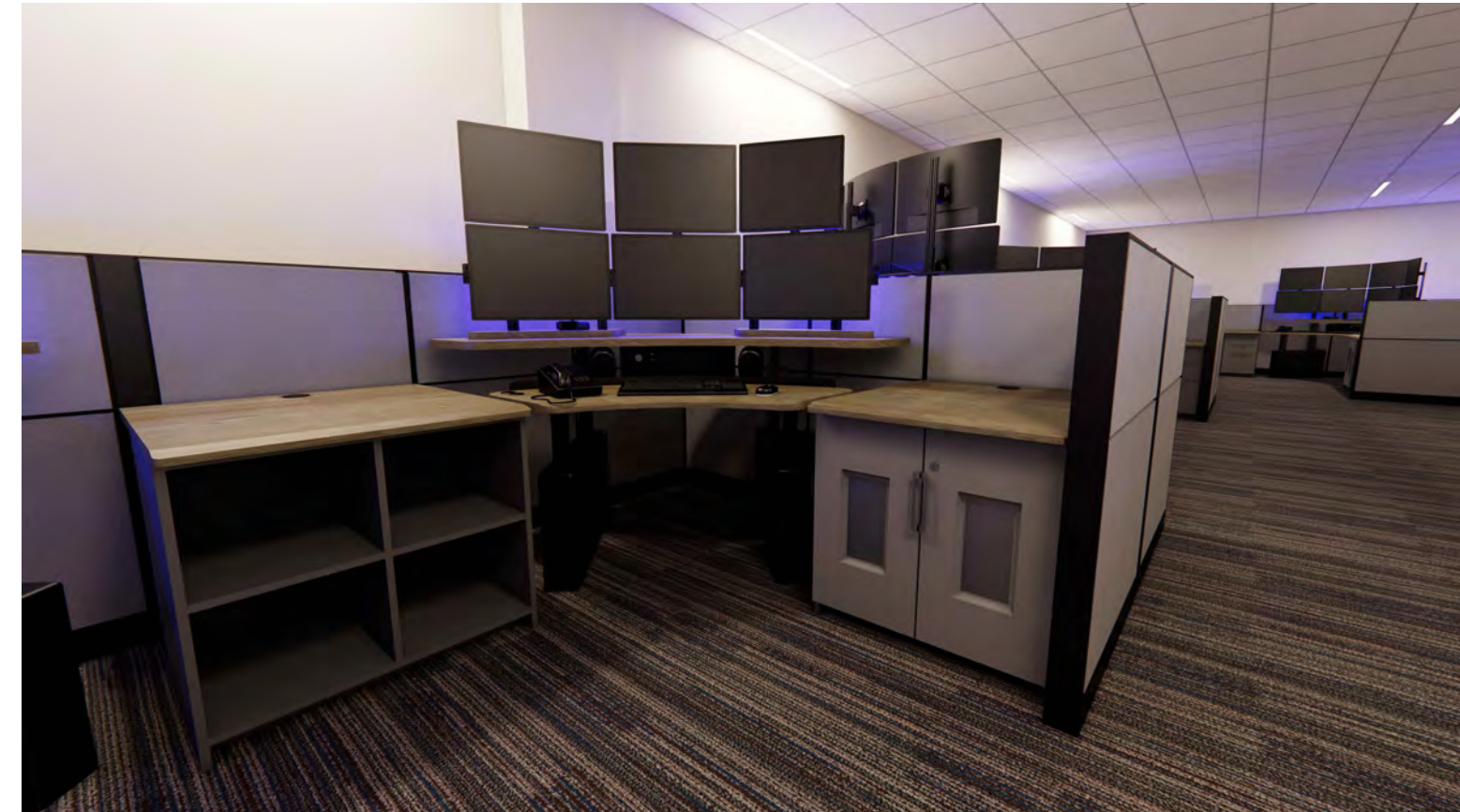
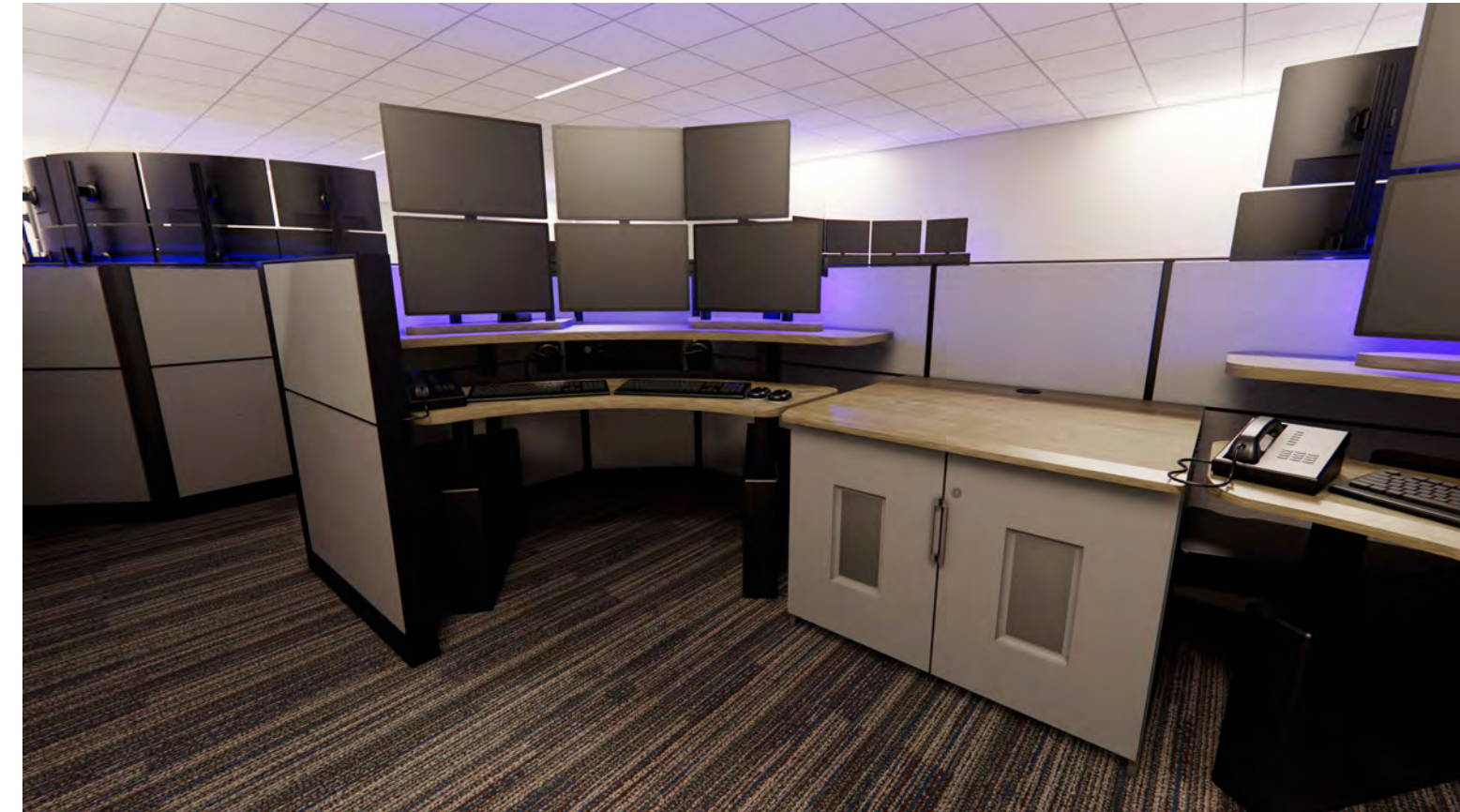

5 3D TYPICAL 72x72
12" = 1'-0"

6 3D TYPICAL 66x66
12" = 1'-0"

7 3D TYPICAL 60x60
12" = 1'-0"

8 3D SUPERVISOR
12" = 1'-0"

Xybix 72"x72" Dual Surface Console with true sit to stand adjustment range of 22"-48" AFF, with L5S Table Base.

axys Control System with Fan
User Interface controlled through Windows, Andriod, and IOS

- Heat: (2) 250w Forced Air Heaters
- Task Light: (2) Dimmable lights with flexible mounting arm on keyboard surface.
- Down Bias Lighting
- Arc Lighting

Xybix 66"x66" Dual Surface Console with true sit to stand adjustment range of 22"-48" AFF, with L4 Table Base.

axys Control System with Fan
User Interface controlled through Windows, Andriod, and IOS

- Heat: (2) 250w Forced Air Heaters
- Task Light: (2) Dimmable lights with flexible mounting arm on keyboard surface.
- Down Bias Lighting
- Arc Lighting

Xybix 60"x60" Dual Surface Console with true sit to stand adjustment range of 22"-48" AFF, with L4 Table Base.

axys Control System with Fan
User Interface controlled through Windows, Andriod, and IOS

- Heat: (2) 250w Forced Air Heaters
- Task Light: (2) Dimmable lights with flexible mounting arm on keyboard surface.
- Down Bias Lighting
- Arc Lighting

Xybix 72"x72" Dual Surface Console with true sit to stand adjustment range of 22"-48" AFF, with L5S Table Base.

axys Control System with Fan
User Interface controlled through Windows, Andriod, and IOS

- Heat: (2) 250w Forced Air Heaters
- Task Light: (2) Dimmable lights with flexible mounting arm on keyboard surface.
- Down Bias Lighting
- Arc Lighting

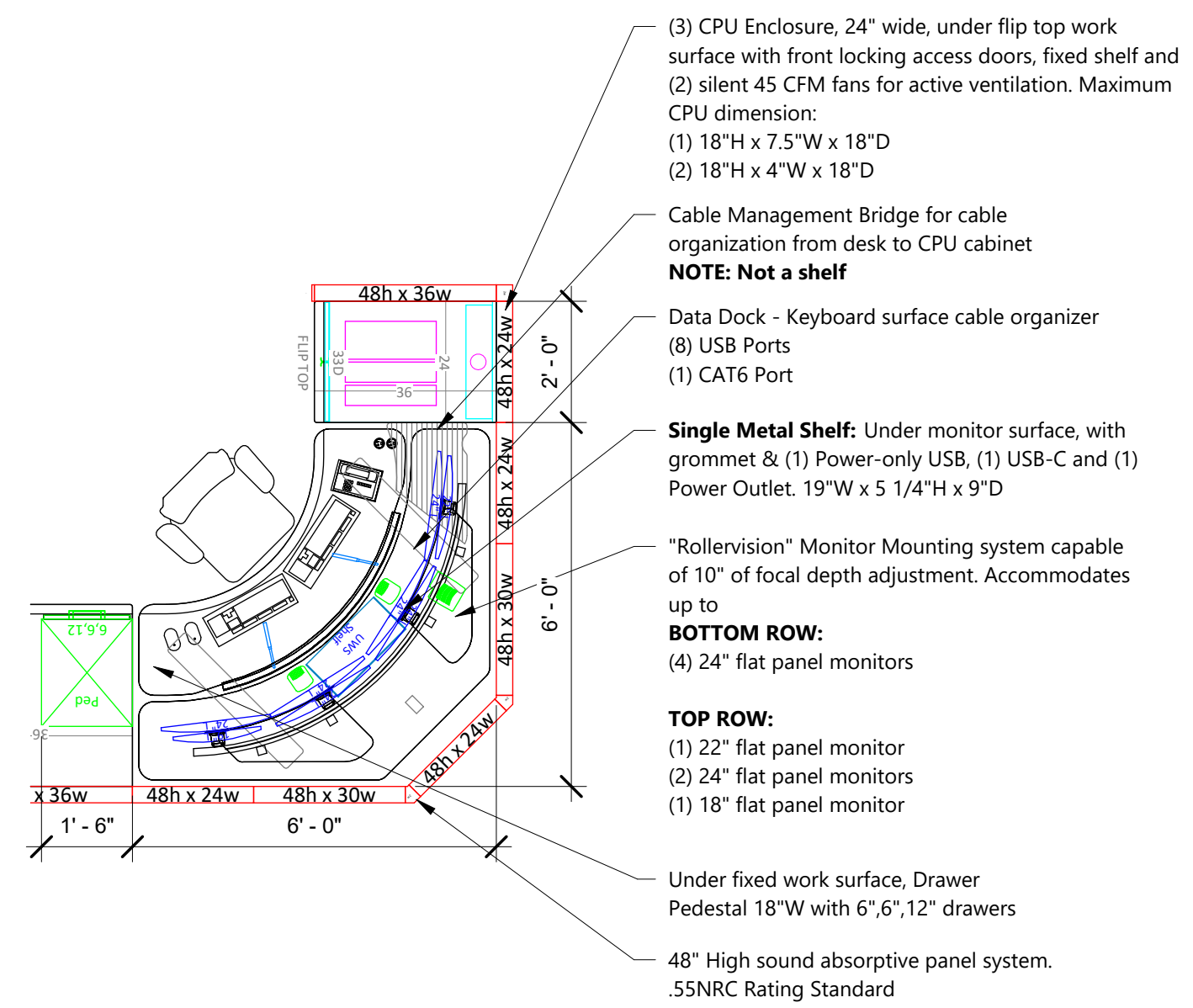

1 TYPICAL 72x72
3/8" = 1'-0"

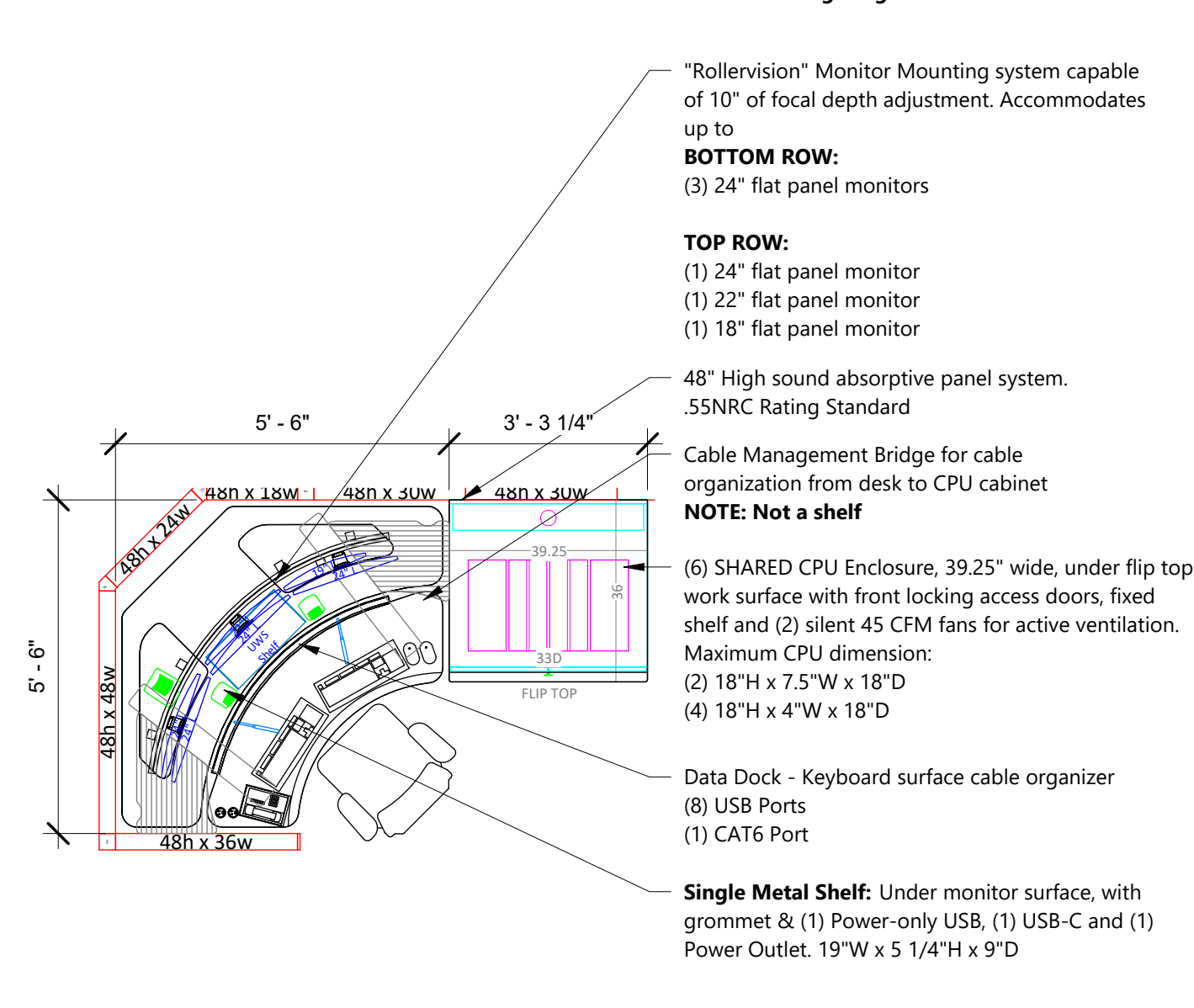

2 TYPICAL 66X66
3/8" = 1'-0"

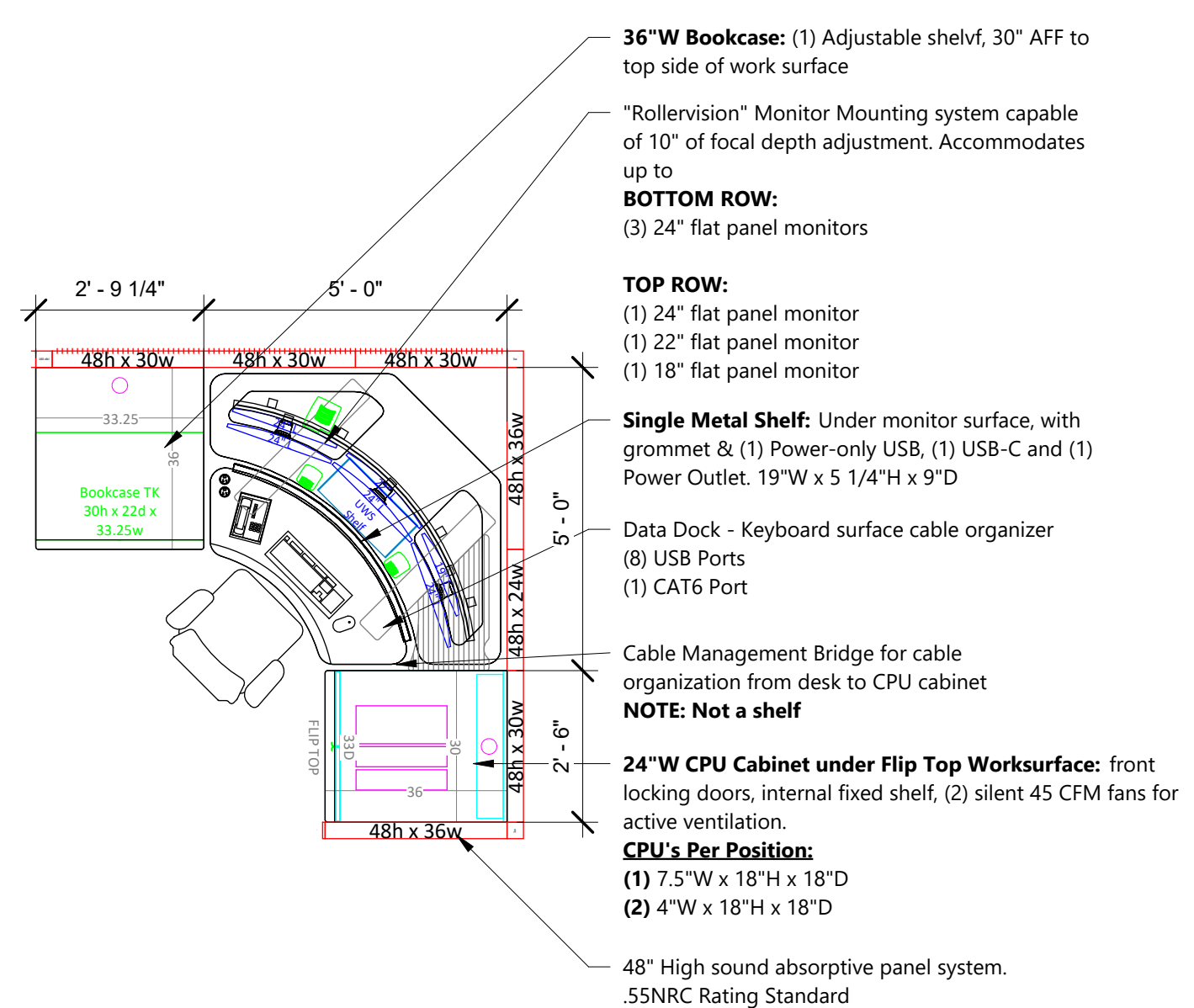

3 TYPICAL 60x60
3/8" = 1'-0"

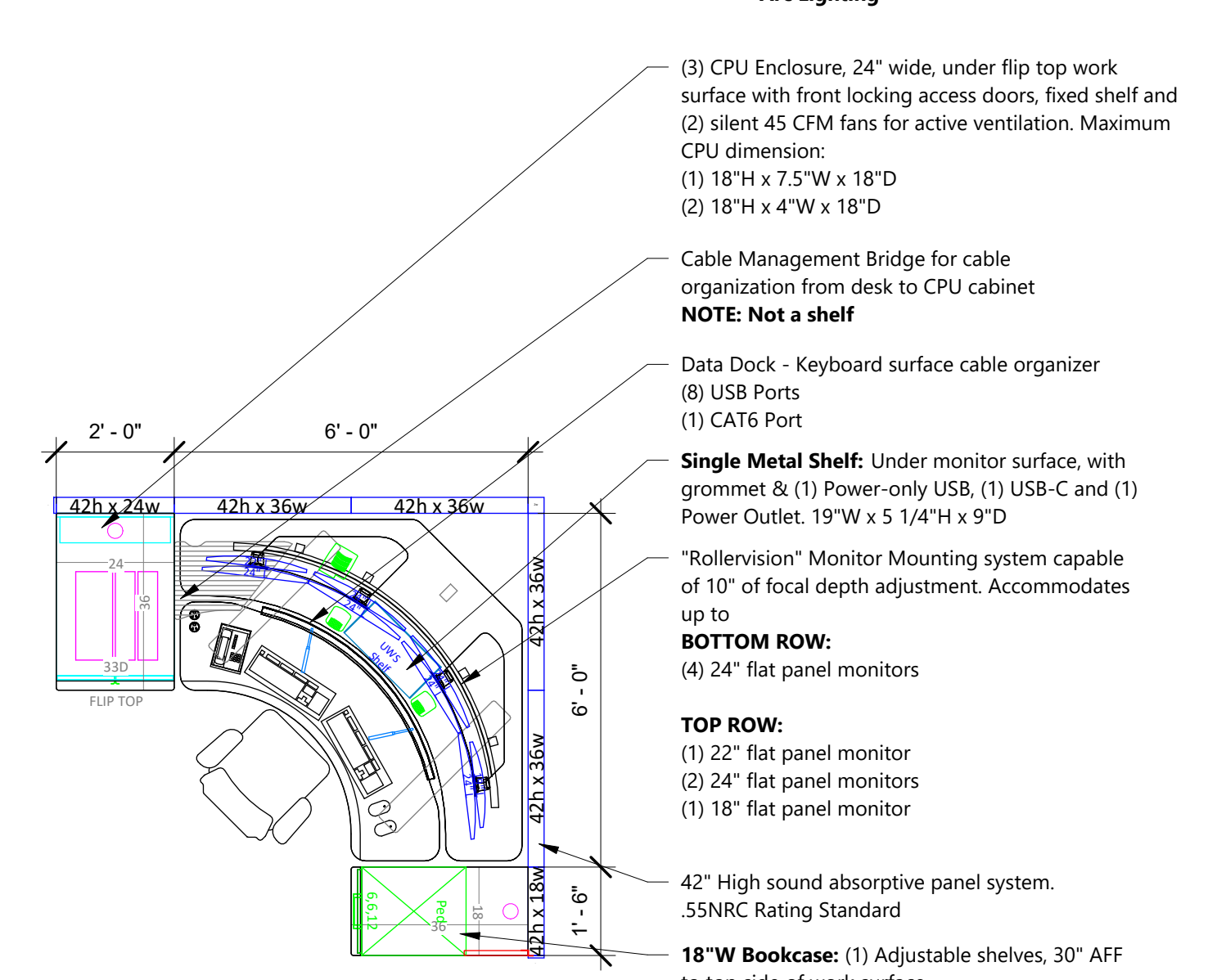

4 SUPERVISOR
3/8" = 1'-0"

Opportunity: 0025551
Carpet Opp: 0027383
Drawing Name:
TYPICALS

SHEET: D3.0
SCALE: As indicated

NOTE: This design & layout is the property of XYBIX Systems, Inc. & is not to be used in any written manner without express written permission by XYBIX Systems, Inc.

Sign-Off Initials: REV
14



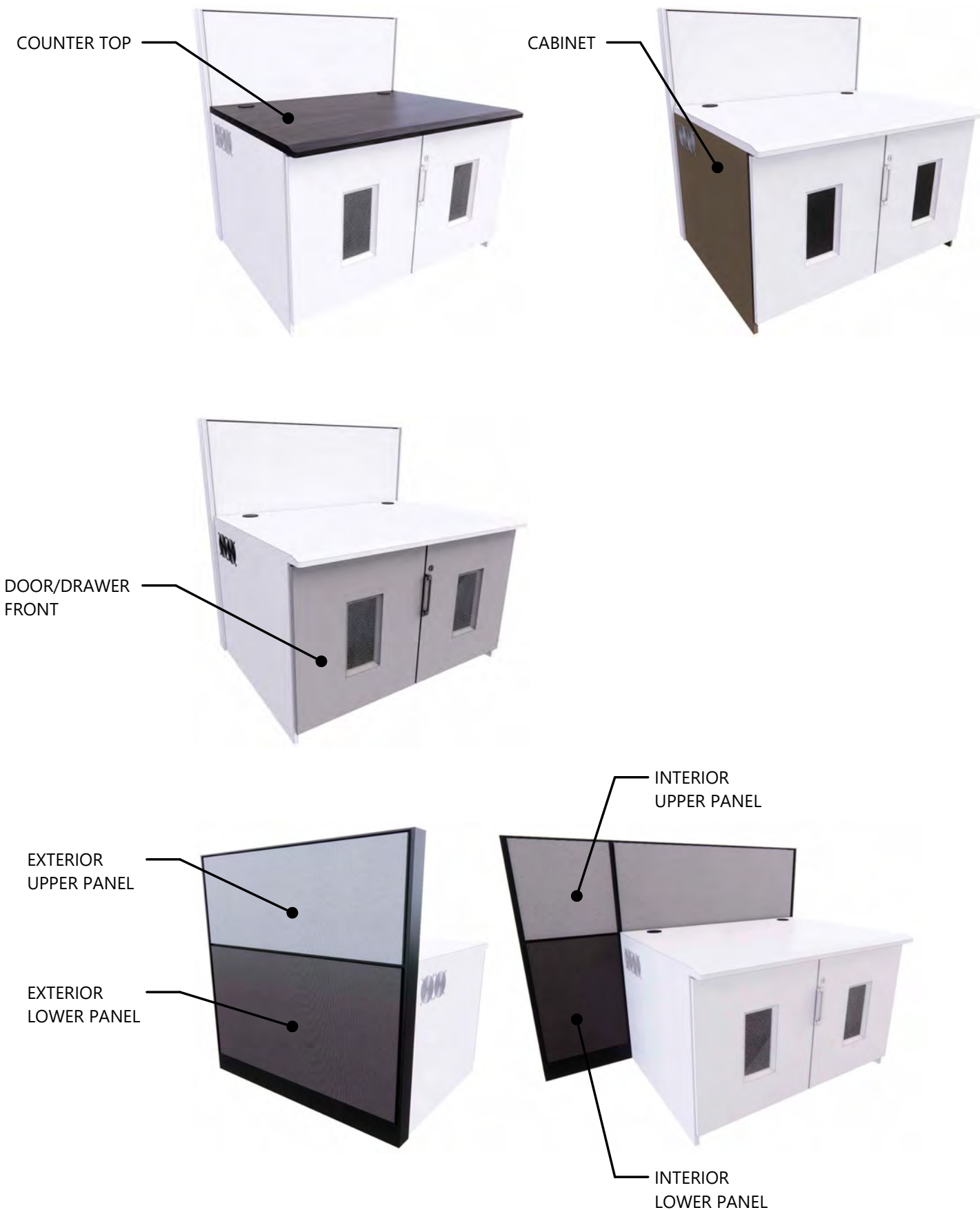

REV	DESCRIPTION	DATE	DESIGNER
10	Update Finishes & Cables	08.14.23	Kmrr
11	Update Carpet Finish / Update Layout - (3) OPTIONS	08.30.23	Kmrr
12	Option 2 Selected	10.09.23	Kmrr
13	Remove Footwell Lighting	11.07.23	Kmrr
14	Reduce Worksurface between W51 & 2 to allow proper ADA Clearance at W6 & 9	11.29.23	Kmrr

FINISH LOCATIONS



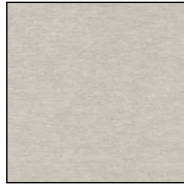
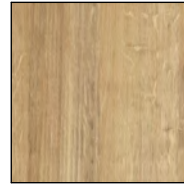

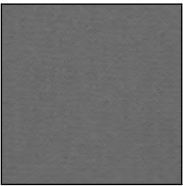
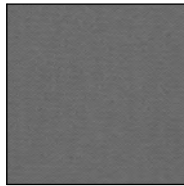
FINISH SELECTIONS

Panel Trim : Black
Interior Upper Panel : CF Stinson Shift Aqueduct 64497
Interior Lower Panel : CF Stinson Focus Shade FOS55
Exterior Upper Panel : CF Stinson Shift Aqueduct 64497
Exterior Lower Panel : CF Stinson Focus Shade FOS55
Counter Top : Dackor Riviera Oak, Mistral D097
Door & Drawer Front : surf(x) Matte Luxe, Linen 537142
Cabinet : Panolam Storm TFL S565
Edgeband : Panolam Storm TFL match
Handle : Eagle Silver

<u>Interior Upper Panel</u>  SHIFT AQUEDUCT	<u>Exterior Upper Panel</u>  SHIFT AQUEDUCT	<u>Counter Top</u>  RIVIERA OAK MISTRAL	<u>Handle</u>  SILVER
<u>Interior Lower Panel</u>  FOCUS SHADE	<u>Exterior Lower Panel</u>  FOCUS SHADE	<u>Cabinet</u>  STORM	<u>Door/Drawer Front</u>  MATTE LUXE LINEN

CARPET SELECTIONS

Carpet : Niagara
Cove Base : Charcoal
Installation Method : Monolithic

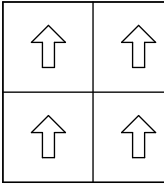
<u>Carpet</u>  NIAGARA	<u>Cove Base</u>  CHARCOAL	<u>Installation Method</u>  MONOLITHIC
---	---	---



8207 SouthPark Circle
 Littleton, CO. 80120
 1.800.788.2810 F.303.683.5454
 www.xybix.com

Sales : Brittany Williams
 Email : BrittanyW@xybix.com
 Designer : Sarah Noonan
 Email : SarahN@xybix.com

Yolo Emergency Communications Upgrade
 34 N Cottonwood Street
 Woodland, CA 95695

Opportunity: 0025551
 Carpet Opp: 0027383
 Drawing Name:
 FINISH SELECTION

SHEET: D6.0 SCALE: 3/8" = 1'-0"

NOTE: This design & layout is the property of XYBIX Systems, Inc. & is not to be used in any written manner without express written permission by XYBIX Systems, Inc.

Sign-Off Initials: _____ REV 14

CABLE EXTENSIONS (PER POSITION)

POSITION(S) TYPE: **WS 8-11**



8207 SouthPark Circle
Littleton, CO. 80120
1.800.788.2810 F.303.683.5454
www.xybix.com

Sales : Brittany Williams
Email : BrittanyW@xybix.com
Designer : Sarah Noonan
Email : SarahN@xybix.com

Yolo Emergency Communications Upgrade
34 N Cottonwood Street
Woodland, CA 95695

DUAL SURFACE DATADOCK CABLES (For Keyboard, Mouse and Phone connections)

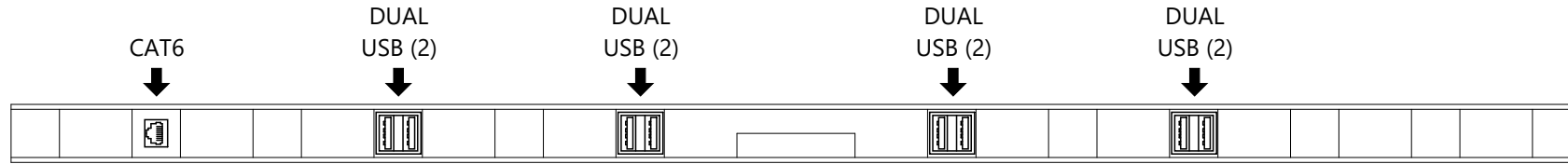

MONITOR SURFACE CABLES

CABLE TYPE	VGA Male / Female Extension Standard Connection for monitors.	DVI-D Male / Female Extension Typical for Hi-Resolution	DVI-I 10' Max Length Male / Female Extension Typical for Hi-Resolution	HDMI Male / Male Extension Typical for Hi-Resolution
QUANTITY				
CABLE TYPE	Display Port Male / Male Extension Typical for Hi-Resolution	Display Port to Mini Display Port	USB	AUDIO Typical for Speakers
QUANTITY	6 ea.			

CABLE ADAPTOR TYPE	DUAL USB (2) (Cable Managed to CPU Cabinet) Keyboard & Mouse	CHARGE ONLY - DUAL USB (2) (Cable Managed to Power Outlet) Cell Phone charging	CAT6 (Max. 2) (Cable Managed to CPU Cabinet) Phone ONLY not for Networking
QUANTITY	8 Total	N/A	1 Total LOCATED ON LEFT SIDE

Datadock has (5) additional slots for expansion if more than (8) USB's and (1) CAT6 is needed. Please note that additional cables will be charged separately.

KEYBOARD SURFACE CABLES (ONLY applies for Monitor or Touchscreen sitting on Keyboard Surface)

CABLE TYPE	VGA Male / Female Extension Standard Connection for monitors.	DVI-D Male / Female Extension Typical for Hi-Resolution	DVI-I 10' Max Length Male / Female Extension Typical for Hi-Resolution	HDMI Male / Male Extension Typical for Hi-Resolution	Display Port Male / Male Extension Typical for Hi-Resolution	USB Keyboard & Mouse	CAT6 Phone ONLY
QUANTITY							

OPTIONAL ITEMS FOR MONITOR SURFACE (EX: CABLE ADAPTORS, USB'S)

CABLE ADAPTOR TYPE	_____	_____	_____	_____
	TO	TO		
QUANTITY				

Opportunity: 0025551
Carpet Opp: 0027383
Drawing Name:
CABLE SHEET

SHEET: D7.0 SCALE:
NOTE: This design & layout is the property of XYBIX Systems, Inc. & is not to be used in any written manner without express written permission by XYBIX Systems, Inc.

If different cable connector types are required it is your responsibility to contact your Designer or Sales Rep. You agree that any changes to this order following receipt of sign-off drawing and PO may result in additional cost that will be expensed to the client.

Signature: _____

Date: _____

Sign-Off Initials: _____
REV **14**

CABLE EXTENSIONS (PER POSITION)

POSITION(S) TYPE: WS 1-7 / WS12 (SUP)



8207 SouthPark Circle
Littleton, CO. 80120
1.800.788.2810 F.303.683.5454
www.xybix.com

Sales : Brittany Williams
Email : BrittanyW@xybix.com
Designer : Sarah Noonan
Email : SarahN@xybix.com

Yolo Emergency Communications Upgrade
34 N Cottonwood Street
Woodland, CA 95695

DUAL SURFACE DATADOCK CABLES (For Keyboard, Mouse and Phone connections)

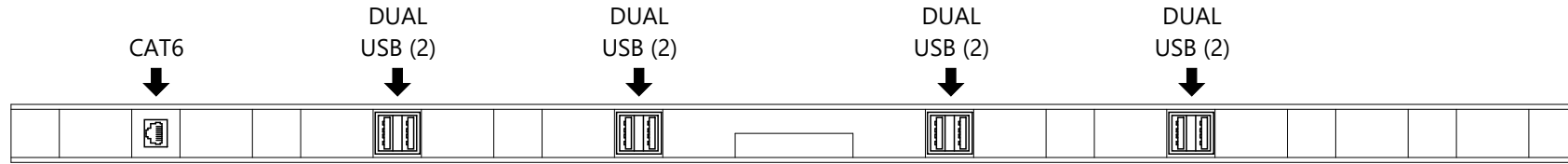

CABLE ADAPTOR TYPE	 DUAL USB (2) (Cable Managed to CPU Cabinet) Keyboard & Mouse	 CHARGE ONLY - DUAL USB (2) (Cable Managed to Power Outlet) Cell Phone charging	 CAT6 (Max. 2) (Cable Managed to CPU Cabinet) Phone ONLY not for Networking	***Datadock has (5) additional slots for expansion if more than (8) USB's and (1) CAT6 is needed. Please note that additional cables will be charged separately.***
QUANTITY	8 Total	N/A	1 Total LOCATED ON LEFT SIDE	

MONITOR SURFACE CABLES

CABLE TYPE	 VGA Male / Female Extension Standard Connection for monitors.	 DVI-D Male / Female Extension Typical for Hi-Resolution	 DVI-I 10' Max Length Male / Female Extension Typical for Hi-Resolution	 HDMI Male / Male Extension Typical for Hi-Resolution
QUANTITY				
CABLE TYPE	 Display Port Male / Male Extension Typical for Hi-Resolution	 Display Port to Mini Display Port	 USB	 AUDIO Typical for Speakers
QUANTITY	8 ea.			

KEYBOARD SURFACE CABLES (ONLY applies for Monitor or Touchscreen sitting on Keyboard Surface)

CABLE TYPE	 VGA Male / Female Extension Standard Connection for monitors.	 DVI-D Male / Female Extension Typical for Hi-Resolution	 DVI-I 10' Max Length Male / Female Extension Typical for Hi-Resolution	 HDMI Male / Male Extension Typical for Hi-Resolution	 Display Port Male / Male Extension Typical for Hi-Resolution	 USB Keyboard & Mouse	 CAT6 Phone ONLY
QUANTITY							

OPTIONAL ITEMS FOR MONITOR SURFACE (EX: CABLE ADAPTORS, USB'S)

CABLE ADAPTOR TYPE	TO	TO		
QUANTITY				

Opportunity: 0025551
Carpet Opp: 0027383
Drawing Name:
CABLE SHEET

SHEET: D7.1
SCALE:

NOTE: This design & layout is the property of XYBIX Systems, Inc. & is not to be used in any written manner without express written permission by XYBIX Systems, Inc.

If different cable connector types are required it is your responsibility to contact your Designer or Sales Rep. You agree that any changes to this order following receipt of sign-off drawing and PO may result in additional cost that will be expensed to the client.

Signature: _____

Date: _____

Sign-Off Initials: _____
REV
14

GENERAL ELECTRICAL NOTES	
--	Comments
1.	Xybix CANNOT recommend the number of circuits or power requirements for your stations. Please consult with an electrical engineer, your architect, local or city electrician for compliance with local electrical codes.
2.	Some radio and phone equipment manufacturers have specific electrical requirements, so consult with them as well.
3.	Most common set up is typically three circuits per station. (2) 20-Amp UPS circuits & (1) 20-Amp non-UPS circuit. Please contact Xybix to discuss other solutions if this is not a feasible.
4.	Non-UPS/Building Power circuit is used for connecting non-critical equipment (MyClimate, adjustable table lifts, task lights, USB charging, etc.). UPS circuits are used for connecting critical equipment (Computers, monitors, radios, or other critical equipment)
5.	(6) outlets for the two UPS circuits and (2) outlets for non-UPS building power circuit is the most common application. If possible, the wires should be fed through a MC conduit to the receptacle box. The MC conduit with extra length coiled under the floor allows for the flexibility to move it in any future layout changes. MC conduit can be run through the panel frame system to be installed in the cpu cabinets.
6.	Another option is to have receptacles in the wall at each station and the Xybix panel system will hide it. When placed at the correct height it will be easy to access. Xybix will plug the power bars into the receptacles. The panel must be tight up against the wall for this method to work.
7.	Xybix will plug into these receptacles using custom made power bars. These have 15-25ft cords and 6 or 10 outlets on each one. Xybix typically supplies 4-6 of these per station, depending on layout and equipment (see "Electrical Diagram" document). Xybix will supply orange and black labels on the power bars to help differentiate between UPS (orange) and building power (black) circuits. Typically, there is one black labeled power bar per station and all others will be labeled orange.
8.	Xybix's standard equipment does not require any specific grounding. We recommend that you contact your radio supplier for grounding requirements. However, Xybix does offer several ways to help ground your stations and to meet any required grounding standards. Xybix offers two levels of grounding to meet your needs; Standard Grounding, and R-56 Grounding. The simpler one (Standard Grounding) grounds the panel frames to a buss bar in the CPU cabinet. The more extensive one (R-56) meets the latest Motorola R-56 grounding standard. This option grounds almost everything that is metal in the station. The project electrician will need to attach the grounding network to the buss bar to complete the attachment to the building ground.

HOLE LOCATION

RECOMMENDED: (2) 2" - 3" DIAMETER HOLES PER CPU CABINET 6" APART ON CENTER

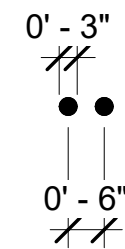

ALL WALL DIMENSIONS TO BE VERIFIED PRIOR TO DRILLING HOLES

HOLE LOCATION PLAN LEGEND
3/8" = 1'-0"

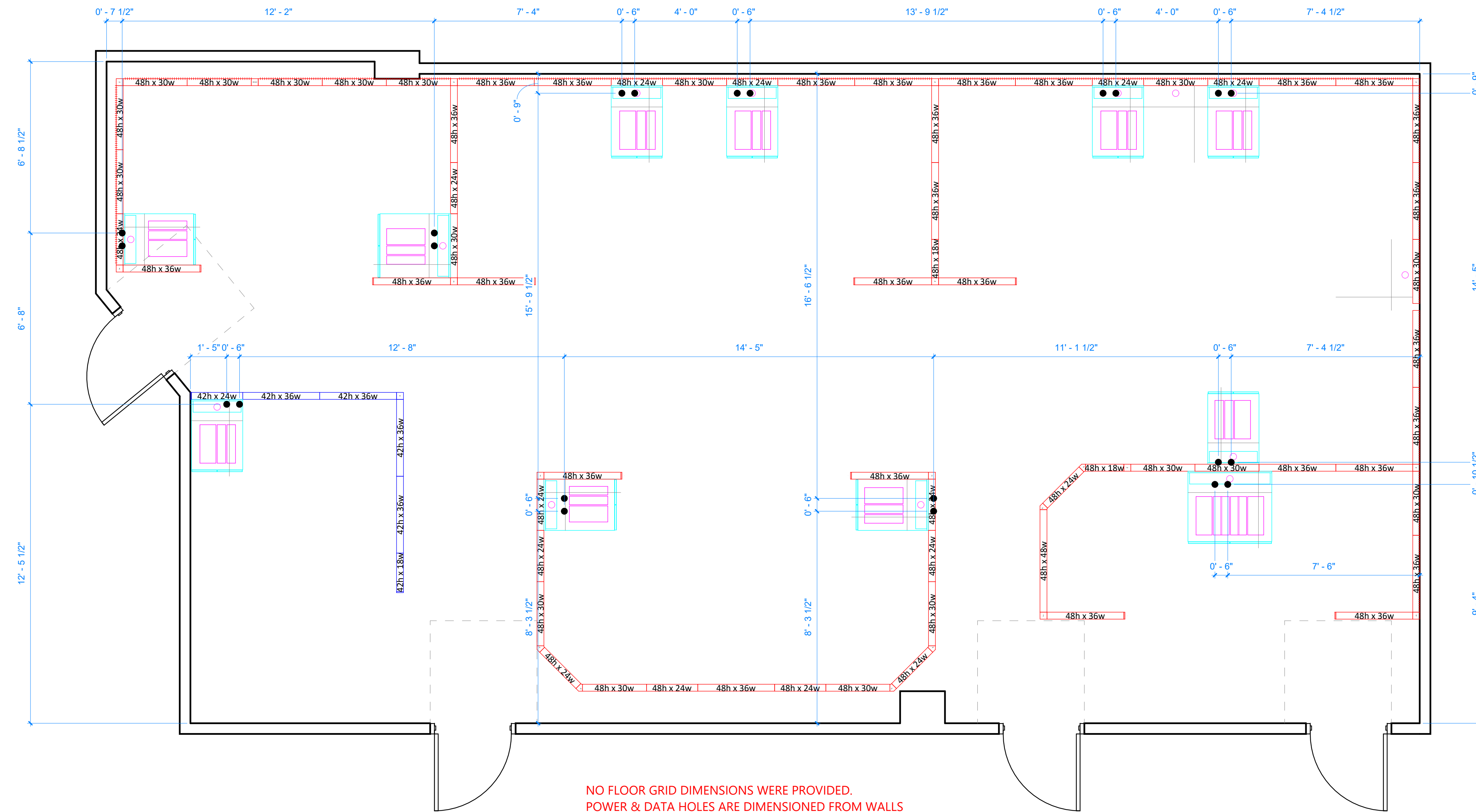

NO FLOOR GRID DIMENSIONS WERE PROVIDED.
POWER & DATA HOLES ARE DIMENSIONED FROM WALLS
HOLE LOCATIONS MUST BE VERIFIED TO ENSURE
THERE ARE NO CONFLICTS WITH EXISTING FLOOR GRID

1 HOLE LOCATION PLAN
3/8" = 1'-0"



8207 SouthPark Circle
Littleton, CO 80120
1.800.782.2810 / 303.483.5454
www.xybix.com

Sales : Brittany Williams
Email : BrittanyW@xybix.com
Designer : Sarah Noonan
Email : SarahN@xybix.com

Yolo Emergency Communications Upgrade
34 N Cottonwood Street
Woodland, CA 95695

Opportunity: 0025551
Carpet Opp: 0027383

Drawing Name:
HOLE LOCATION PLAN

SHEET: D8.0 SCALE: 3/8" = 1'-0"

NOTE: This design & layout is the property of XYBIX Systems, Inc. & is not to be used in any written manner without express written permission by XYBIX Systems, Inc.

Sign-Off Initials: REV 14

REV	DESIGNER	DATE	DESCRIPTION
10	Kmr	08.14.23	Update Finishes & Cables
11	Kmr	08.30.23	Update Carpet Finish / Update Layout - (3) OPTIONS
12	Kmr	10.05.23	Option 2 Selected
13	Kmr	11.07.23	Remove Footwell Lighting
14	Kmr	11.29.23	Reduce Worksurface between W51 & 2 to allow proper ADA Clearance at W5 & 9

SIGN OFF APPROVAL: Furniture orders and product installation shall not proceed until the Client has given approval to these documents. Approval of the Client shall constitute approval of the drawings for contents, scope of work and all dimensions regarded by the Client as being necessary to the use of space, furnishings and equipment. Furniture orders, or product installation authorized by the Client from these documents, shall be interpreted by XYBIX as approval in full to these documents by the Client. Revisions after approval of these documents shall result in additional costs.

Signature: _____ Title: _____ Date: _____

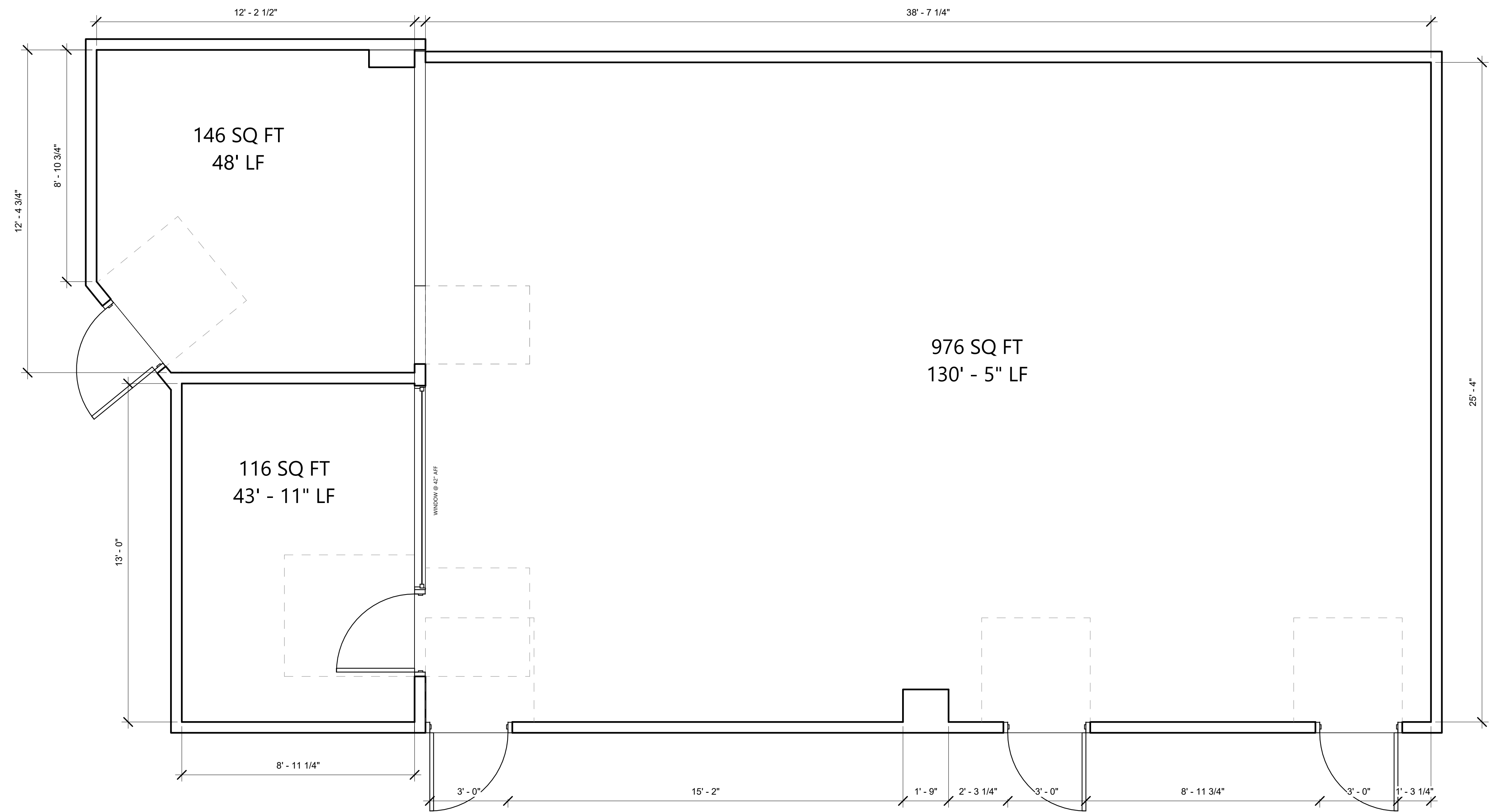
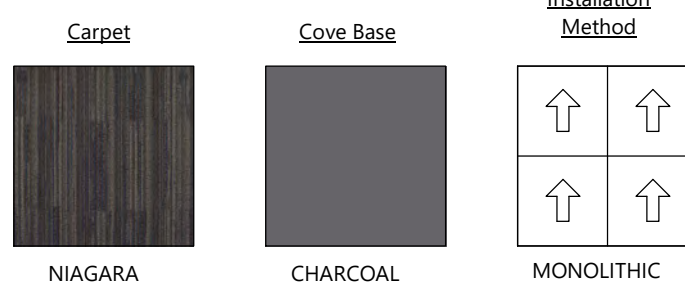

CEILING HEIGHT: 9' - 0"
POWER/DATA COMING FROM: FLOOR

1 CARPET PLAN
3/8" = 1'-0"



8207 SouthPark Circle
Littleton, CO 80120
1.800.788.2310 F. 303.683.5454
www.xybix.com

Sales: Brittany Williams
Email: BrittanyW@xybix.com
Designer: Sarah Noonan
Email: SarahN@xybix.com

Yolo Emergency Communications Carpet
34 N. Cottonwood Street
Woodland, CA 95695

Opportunity: 0027383
Carpet Opp:
Drawing Name: CARPET PLAN
SHEET: D11.0 SCALE: 3/8" = 1'-0"

NOTE: This design is based on the property of XYBIX Systems, Inc. It is not to be used in any written manner without express written permission by XYBIX Systems, Inc.

Sign-Off Initials: REV 1

REV	DATE	DESIGNER	DESCRIPTION
0	01.10.23	SN	Drawing Creation
1	10.09.23	Kmr	Update Carpet to Niagara

Signature: _____ Title: _____ Date: _____

SIGN OFF APPROVAL: Furniture orders and product installation shall not proceed until the Client has given approval to these documents. Approval of the Client shall constitute approval of the drawings for contents, scope of work and all dimensions regarded by the Client as being necessary to the use of space, furnishings and equipment. Furniture orders, or product installation authorized by the Client from these documents, shall be interpreted by XYBIX as approval in full to these documents by the Client. Revisions after approval of these documents shall result in additional costs.



PROJECT MANUAL

Volume I: Bidding and Contracting Requirements



Yolo County 911 Dispatch Center Tenant Improvement Project
Woodland, CA 95695

June 26, 2024

Bids Due before 2:00PM, Thursday, August 15, 2024 at
Yolo County General Services
Procurement Division
120 West Main Street, Suite G
Woodland, CA 95695



THIS PAGE INTENTIONALLY LEFT BLANK



SECTION 00 01 10

TABLE OF CONTENTS

VOLUME 1: BIDDING AND CONTRACTING REQUIREMENTS

DIVISION 00 – BIDDING AND CONTRACTING REQUIREMENTS

00 01 10	Table of Contents
00 01 15	List of Bid Documents
00 12 00	Notice to Bidders
00 20 00	Instructions to Bidders
00 41 00	Bid Form with Bid Schedule
00 42 00	Bidder's Bond
00 43 00	Subcontractor List
00 44 00	Bidder Information Sheet
00 45 00	List of Successful Projects
00 45 10	Non-Collusion Declaration
00 45 26	Joint Apprenticeship Committee Certification
00 45 27	Statement re No Apprenticeship Violation
00 45 28	Acknowledgment re: Health Care Expenditure Requirement
00 45 46	Certification Against Lobbying-reserved
00 51 00	Notice of Award
00 52 00	Construction Agreement (Contract)
00 55 00	Notice to Proceed
00 61 00	Performance Bond
00 62 00	Payment Bond
00 62 10	Indemnification
00 62 20	Iran Contacting Act
00 62 21	Fleet Compliance Certification Form
00 70 00	General Conditions



Yolo County 911 Dispatch Center Tenant
Improvement Project



SECTION 00 01 15

LIST OF BID DOCUMENTS

BID DOCUMENTS

A. PROJECT MANUAL

1. Volume 1: Bidding and Contracting Requirements dated June 26, 2024, rev 7-18-24.
2. Volume 2: Technical Specifications dated April 17, 2024

B. PROJECT PLANS

3. Volume 3: Yolo County 911 Dispatch Center Tenant Improvement Project Plans dated December 21, 2023

C. Asbestos Report-October 27, 2026



SECTION 00 12 00

NOTICE TO BIDDERS

NOTICE IS HEREBY GIVEN that the County of Yolo will receive sealed bids in accordance with the provisions of the Public Contract Code from contractors licensed for the furnishing of all labor, materials, equipment, transportation, mobilization, demobilization, permitting, disposal and any other required services for the performance of the following Work:

Yolo County 911 Dispatch Center Tenant Improvement Project

The extent of work is identified in the Technical Specifications Volume II.

All work to be performed during the hours of 7:30am-5:00pm, Monday through Friday.

Plans and Specifications for the work will be available as noted herein.

All questions regarding Plans and Specifications and Interpretations or Clarifications for this Initiation for Bid must be entered electronically through Periscope (formerly Bid Sync at (<https://www.BidSync.com>)). The County's Project Manager will respond to all Contractor questions through the Periscope (formerly Bid Sync) Question and Answer section on this website.

SEALED BIDS:

Sealed bids on the above project shall be filed with Yolo County General Services Department, Procurement Division, located at 120 West Main Street, Suite G, Woodland, CA 95695, before **2:00 pm** on **Thursday, August 15, 2024.**

All bids must be marked clearly on the envelope:

“Yolo County 911 Dispatch Center Tenant Improvement Project”

Said bids will be opened in public after **2:15 pm** of said day at Yolo County General Services Department -Procurement Division 120 West Main Street, Ste. G Woodland, CA 95695. Bids shall be submitted only on forms provided in the Bid Documents and shall be accompanied by all documents and information required to be submitted by the Instructions to Bidders and by law. No bid may be withdrawn after the time established for receiving bids or before the award and execution of the Contract, unless the award is delayed for a period exceeding one hundred twenty (120) calendar days. The low bidder, for purposes of the award, shall be the responsive bidder offering the low lump sum amount for the base bid and meeting all other bid submittal requirements. The County reserves the right to reject any or all bids.



CONTRACTOR'S LICENSE REQUIRED:

The Board will not consider or accept any bids from contractors who are not licensed to do business in the State of California. Contractor warrants and represents that he/she holds a valid California license pursuant to the State Contractors License Act [Business and Professions Code Section 7000, et seq.], that his/her license is in good standing and that he/she possess a Class A or Class B; C-10, C-12, C-6, C-36 and C-33 license and any other additional licensing needed to perform all required categories and type of work -- or any others as identified per design plan. Copies of the Contractor's State Contractor license(s) must be provided, along with their bid.

REQUIRED LISTING OF PROPOSED SUBCONTRACTORS:

Each proposal shall have listed therein the name and address of each subcontractor to whom the Bidder proposes to subcontract portions of the Work in an amount in excess of one-half of one percent (½ of 1%) of his total Bid in accordance with the Subletting and Subcontracting Fair Practices Act, commencing with Section 4100, through 4113 inclusive of the Public Contract Code. The Bidder's attention is invited to other provisions of said Act related to the imposition of penalties for a failure to observe its provisions by using unauthorized subcontractors or by making unauthorized substitutions.

Notice is hereby given that the Project is a public works project within the requirements of Division 2, Part 7, Chapter 1 of the California Labor Code, and that each bidder and listed subcontractor is required to be registered pursuant to Labor Code section 1725.5 at the time of bidding. Failure of the bidder to be registered at the time of bidding shall render the bid non-responsive and unavailable for award. Bidder's listing of an unregistered subcontractor may render the bid non-responsive and unavailable for award unless such failure is the result of an inadvertent error and the provisions of Labor Code section 1771.1 apply.

JOINT APPRENTICESHIP COMMITTEE PARTICIPATION REQUIREMENT

The County has adopted additional requirements for certain "Covered Projects" as defined in the County's Policy on Procurement. This Project is considered a "Covered Project" and is subject to the County's Joint Apprenticeship Committee (JAC) participation requirement. The County has adopted a JAC participation requirement for certain public projects estimated to cost more than one-million dollars (\$1,000,000). A JAC means an apprenticeship program comprised of an equal number of employer and employee representatives approved by the State of California Division of Apprenticeship Standards. This JAC requirement is in addition to the apprenticeship requirements of the Prevailing Wage Laws.

To satisfy the County's JAC participation requirement, Contractors must submit with their bid the Joint Apprenticeship Committee Participation Certification with signed evidence satisfactory to the Procurement Manager or the Procurement Manager's designee that they participate in a JAC by being a signatory to a JAC or employ registered apprentices dispatched by a JAC. Such evidence may be in the form of a signed letter from a JAC confirming the Contractor is a signatory to a JAC or has hired registered apprentices who are active participants of a JAC.

In addition, Bidders must submit a signed "Statement Re: No Apprenticeship Violation" confirming the Bidder has not been found in violation of any provision of state or local apprenticeship laws or regulations in the past three years.



HEALTH CARE EXPENDITURE REQUIREMENT

The County has also adopted the following health care expenditure requirement for certain public projects estimated to cost more than one-million dollars (\$1,000,000):

Each Contractor with construction craft employees shall make health care expenditures for each such employee in an amount per hour worked on the Covered Project equivalent to at least the hourly pro rata cost of a Covered California Platinum level plan for two 40-year-old adults and two dependents 0 to 14 years of age for the Covered California rating area in which the development is located. Qualifying expenditures shall be credited toward compliance with prevailing wage payment requirements up to the amount determined by the Director of Industrial Relations pursuant to Sections 1773 and 1773.9 of the Labor Code. Health care expenditures in excess of that amount shall not be so credited. "Health care expenditures" include contributions under Sections 501(c) or (d) or 401(a) of the Internal Revenue Code and payments toward "medical care" as defined under Section 213(d)(1) of the Internal Revenue Code. A Contractor that is signatory to a valid collective bargaining agreement that requires payment of at least the prevailing wage, participation in a joint labor-management apprenticeship program, and the provision of health care payments for all construction craft employees shall be deemed in compliance. A Contractor without construction craft employees shall show a contractual obligation that its subcontractors comply with this paragraph.

Bidders must submit a signed Acknowledgment confirming they have read and will comply with this requirement.

CALIFORNIA AIR RESOURCES BOARD REQUIREMENT

The California Air Resources Board ("CARB") implemented amendments to the In-Use Off-Road Diesel-Fueled Fleets Regulations ("Regulation") which are effective on January 1, 2024 and apply broadly to all self-propelled off road diesel vehicles 25 horsepower or greater and other forms of equipment used in California. A copy of the Regulation is available at <https://ww2.arb.ca.gov/sites/default/files/barcu/regact/2022/off-roaddiesel/appa-1.pdf>. Bidders are required to comply with all CARB and Regulation requirements, including, without limitation, all applicable sections of the Regulation, as codified in Title 13 of the California Code of Regulations section 2449 et seq. throughout the duration of the Project. Bidders must provide, with their Bid, copies of Bidder's and all listed subcontractors' most recent, valid Certificate of Reported Compliance ("CRC") issued by CARB. Failure to provide valid CRCs as required herein may render the Bid non-responsive.

The County is a Public Works Awarding Body, as defined under Title 13 California Code of Regulations section 2449(c)(46). Accordingly, Bidders must submit, with their Bids, valid Certificates of Reported Compliance ("CRC") for the Bidder's fleet and for the fleet(s) of its listed subcontractors (including any applicable leased equipment or vehicles). Bidders must additionally complete and submit the Fleet Compliance Certification, included in the Bid Documents. Failure to provide a CRC for the Bidder, and for all listed subcontractors, or failure to complete the Fleet Compliance Certification, may render the Bid non-responsive.



BID EXAMINATION AND PREPARATION:

Project Documents may be obtained at Periscope (formerly Bid Sync) at (<https://www.BidSync.com>) or at the Yolo County Website (under *Doing Business with the County*). Documents will be available beginning on April 18, 2024. It is the bidder's responsibility to arrange for printing services to obtain printed copies of the bid documents. The contract documents may also be examined at the following locations:

Construction Bid Board
Dodge Data & Analytics
Sacramento Regional Builders Exchange
Placer County Contractors Association & Builders

The Bidder shall carefully examine the Bid Documents, including the Plans and Specifications and the Asbestos Inspection Report, and satisfy the Bidder as to their sufficiency, and shall not at any time after submission of the Bid, dispute or complain of such Plans or Specifications nor assert that there is any misunderstanding in regard to the location, extent or nature or amount of work to be performed in accordance thereto. Should a Bidder find discrepancies or omissions in the Plans and Specifications, the Bidder shall notify the Project Manager immediately. Interpretations or clarifications considered necessary by the Project Manager shall be by addenda, mailed or electronically delivered to all plan holders and acknowledged on Bid form. **Questions received after 2:00 p.m. of August 1, 2024 will not be answered. The issuance and release of the final addendum is estimated to be Thursday, August 8, 2024.**

The Bid shall have all items filled in and the signatures of all persons signing the Bid shall be in long-hand. Mistakes must be corrected, and the correction inserted and initialed in ink by the person signing the Bid. Erasures and/or correction fluid are NOT acceptable. Changes must be lined out and corrections inserted adjacent and initialed by the bidder's authorized representative. No proposal will be considered which makes exceptions, changes or reservations to the Plans and Specifications.

The bids must supply all information required by the bid documents & specifications. Bids must be full and complete. The County reserves the right in its sole discretion to reject any bid as non-responsive as a result of any omission or error in the bid.

SUBSTITUTIONS:

Bids shall be based on products and systems specified in the Bid Documents or listed by name in addenda. Contractors and materials suppliers may submit requests for substitutions up to 35 days following Notice of Award.

NON-COLLUSION DECLARATION:

Bidders shall include with their bids a signed declaration under penalty of perjury stating that their bid is not a sham or a collusive bid. The declaration is to be signed exactly as worded; no alternate wording will be accepted. The declaration is included with the bid.



DEBARMENT AND SUSPENSION

By signing and submitting a bid for the Project, Bidder represents and warrants that it is eligible to bid and work on this project pursuant to Sections 1777.1 and 1777.7 of the California Labor Code and other applicable provisions of law. Further, Bidder acknowledges that it is prohibited from performing work on this project with a subcontractor who is ineligible to perform work on public works project pursuant to Sections 1777.1 and 1777.7.

ECONOMIC SANCTIONS

Pursuant to California State Executive Order N-6-22 (“Executive Order”) imposing economic sanctions against Russia and declaring support of Ukraine, County shall terminate any contract with any individual or entity that is in violation of the Executive Order or that is subject to economic sanctions therein and shall not enter a contract with any such individual or entity while the Executive Order is in effect. By signing and submitting a bid, Bidder acknowledges and represents that it is aware of and shall comply with the Executive Order and that Bidder is not a target of economic sanctions pursuant to the Executive Order or the federal government, nor is Bidder conducting prohibited transactions with sanctioned individuals or entities. Violation of the Executive Order shall be grounds for County to terminate the Construction Agreement.

BONDS AND INSURANCE REQUIRED:

A bid security shall be provided with each Bid. Bid security shall be in an amount of not less than ten percent (10%) of the total amount of the Bid and shall be cash, a certified check or cashier's check drawn to the order of the County of Yolo or a Bidder's Bond executed by a surety satisfactory to the County of Yolo in the form provided in the Proposal section of these Bid Documents. The Bidder to whom award is made shall provide Certificates of Insurance as required in Article 2 of the General Conditions, and shall complete and submit the Performance Bond and Payment Bond forms contained in the Contract Documents.

PREVAILING WAGE PROVISION:

- a. Pursuant to Labor Code Section 1770 et seq., 1773, 1773.1, 1773.2, 1773.6, 1773.7, and 1720 each laborer or mechanic of contractor or any subcontractor engaged in work on the project under this Contract shall be paid not less than the hourly wage rate of per diem wages set forth in the prevailing wage rate schedule published by the Director of Industrial Relations regardless of any contractual relationship which may be alleged to exist between contractor or any subcontractor and such laborers and mechanics. Interested parties may obtain the current wage information by submitting their requests to the Department of Industrial Relations, Division of Labor Statistics and Research, P.O. Box 603, San Francisco, CA 94101, or at www.dir.ca.gov/dlsr/pwd.
- b. Any laborer or mechanic employed to perform work on the project under this Contract, which work is not covered by any of the foregoing classifications, shall be paid not less than the prevailing rate of per diem wages specified herein for the classification which most nearly corresponds to the work to be performed by him/her.



- c. The foregoing specified prevailing wage rates are minimum rates only, and the contractor may pay any wage rate in excess of the applicable rates contained in this Contract.
- d. Pursuant to Labor Code Section 1775, the contractor as a penalty to the owner shall forfeit \$200.00 for each calendar day, or portion thereof for each worker paid less than the prevailing rate established by the Department of Industrial Relations for such work or craft in which such worker is employed. The difference between such prevailing wage rates and the amount paid to each worker for each calendar day or portion thereof for which the worker was paid less than the prevailing wage rate shall be paid to each worker by the contractor. NOTE: an error on the part of an awarding body does not relieve the contractor from responsibility for payment of the prevailing rate of per diem wages and penalties pursuant to Labor Code Sections 1770-1775.
- e. Prevailing wage rates are available through the following website:
<https://www.dir.ca.gov/OPRL/dprevagedetermination.htm>.
- f. All contractors and subcontractors are subject to the provisions of Sections 1810 through 1814 of the California Labor Code which provide for the maximum hours a worker is to be employed and the amount and rate of overtime compensation.

AWARD OF CONTRACT:

Bids will be considered for award by the Yolo County General Services Department. The County of Yolo reserves the right after opening bids to reject any or all bids, or to waive any informality (non-responsiveness) in any bid, or to make award to the lowest responsive, responsible bidder and reject all other bids, as it may best serve the interests of the County.

If this Contract is to be awarded, the Notice of Award shall be issued to the lowest responsive, responsive bidder within One-Hundred Twenty (120) days following the bid opening.

As a condition of award, the successful Bidder will be required to submit bonds and evidence of insurance prior to execution of the Agreement by the County. Failure to meet this requirement shall constitute abandonment of the Bid by the Bidder and forfeiture of the Bid Bond. Award will then be considered to the next lowest responsible Bidder.

All bids will be compared using the Opinion of Probable Cost prepared by the AE of Record for the project. For the purposes of bonding, the OPC for the base bid work is in the range of \$399,000.00.

REMAINDER OF PAGE INTENTIONALLY LEFT BLANK

////////////////////////////////////



SECTION 00 20 00

INSTRUCTIONS TO BIDDERS

1. Bids are requested for a general construction contract, or work described in general, as follows:
Yolo County 911 Dispatch Center Tenant Improvement Project
2. The County of Yolo will receive sealed bids from Bidders as stipulated in Document 00 12 00, Notice to Bidders.
3. Apparent low Bid will be based solely on: Base Bid Price. All Bidders are required to submit Bids on all bid items.
4. Bidders must submit bids on Document 00 41 00 Bid Form. Bids not submitted on the required form shall be deemed non-responsive and shall not be considered.
5. Bidders must submit cash, a cashier's check, a certified check or a corporate surety bond of not less than ten percent (10%) of amount bid, payable to the County, with their Bids. Required form of corporate surety bond, Document 00 42 00 County of Yolo Bidder's Bond, is provided by the County. Bids submitted without necessary bid security will be deemed non-responsive and will not be considered.
6. Bidders must submit names of all subcontractors and their respective bid item sub-bids on Document 00 43 00 Subcontractors List for those subcontractors who will perform any portion of Work, including labor, rendering of service, or specially fabricating and installing a portion of the work or improvement according to detailed drawings contained in the plans and specifications, in excess of one half of one percent (0.5%) of total bid. Any violation of this provision may result in Bid being deemed non-responsive and not being considered.
7. Bidders must submit Document 00 44 00 Bidder Information Sheet with their bids. Bids submitted without the Bidder Information Sheet will be deemed non-responsive and will not be considered.
8. Bidders must submit Document 00 45 00 List of Successful Projects. Bids submitted without the list will be deemed non-responsive and will not be considered.
9. Bidders must submit Document 00 45 10 Non-collusion Declaration with their bids. Bids submitted without the declaration will be deemed non-responsive and will not be considered.



10. Bidders must submit Document 00 45 26 Joint Apprenticeship Committee Certification
11. Bidders must submit Document 00 45 27 Statement re No Apprenticeship Violation
12. Bidders must submit Document 00 45 28 Acknowledgment re: Health Care Expenditure Requirement
13. Bidders must submit Document 00 45 46 Certification Against Lobbying with their bids. Bids submitted without the certification will be deemed non-responsive and will not be considered.
(reserved)
14. Bidders must submit Document 00 62 20 Iran Contacting Act with their bids. Bids submitted without the certification will be deemed non-responsive and will not be considered.
15. Bidders must submit Document 00 62 21 Fleet Compliance Certification with their bid. Bids submitted without the form will be deemed non-responsive and will not be considered.
16. Bidders must supply all information required by Bid documents and specifications. Bids must be full and complete. The County reserves the right in its sole discretion to reject any Bid as non-responsive as a result of any error or omission in the Bid.
17. A mandatory Pre-bid Conference and Site Visit will be held as referenced in Document 00 12 00, Notice to Bidders, to clarify such matters as Bidders may request. The referenced Pre-bid Conference and Site Visit will take approximately two hours. The County will transmit to all prospective Bidders of record such Addenda as the County in its discretion considers necessary in response to questions arising at the Pre-bid Conference. The sign in sheet at the Pre-bid conference will be posted by addendum on Periscope (formerly Bid Sync) following the Pre-bid conference. Oral statements shall not be relied upon and will not be binding or legally effective. Addenda issued as a result of the Pre-bid Conference, shall constitute the sole and exclusive record and statement of the results of the Pre-bid Conference.



18. Bids shall be clearly written without erasure or deletions. The County reserves the right to reject any Bid containing erasures or deletions.
19. Bidders may not modify Bid Form or qualify their Bids.
20. Submission of Bid signifies careful examination of Contract Documents and complete understanding of the nature, extent and location of Work to be performed. Bidder must complete the tasks listed below in subsections as a condition to bidding and submission of Bid shall constitute the Bidder's express representation to the County that Bidder has fully completed the following:
 - (A) Bidder has visited the site and has examined thoroughly and understood the nature and extent of the Contract Documents, Work, existing facility conditions for demolition and removal, Site, locality, actual conditions, existing access and facility conditions, and all local conditions and federal, state and local laws and regulations that in any manner may affect cost, progress, performance or furnishing of Work or which relate to any aspect of the means, methods, techniques, sequences or procedures of construction to be employed by Bidder and safety precautions and programs incident thereto;
 - (B) Bidder has given Project Manager prompt written notice of all conflicts, errors, ambiguities or discrepancies that it has discovered in or among the Contract Documents and as-built and actual conditions and the written resolution thereof by Project Manager is acceptable to Bidder.



21. Copies of the general prevailing rates of per diem wages for each craft, classification, or type of worker needed to execute the Contract, as determined by Director of the State of California Department of Industrial Relations, are deemed included in the bid documents.
 - (C) **DIR REGISTRATION AND NOTICE:** To be qualified to bid on, be listed in a bid proposal or engage in the performance of any public work contract subject to Labor Code section 1720, contractors and subcontractors must be registered with the Department of Industrial Relations. Failure to provide this information at the time of bid will result in disqualification. Please see <http://www.dir.ca.gov/Public-Works/PublicWorks.html> for more information. No contract will be entered into without proof of the contractor's and subcontractors' current registration with the Department of Industrial Relations to perform public work provided at the time of bid. If awarded a contract, the bidder and its subcontractors, at all tiers, shall maintain active registration with the Department of Industrial Relations for the duration of the project. This Project is subject to compliance monitoring and enforcement by the Department of Industrial Relations. Each contractor and subcontractor must furnish certified payroll records to the Labor Commissioner at least monthly.
 - (D) A ***reminder*** to General Contractors in regard to State Public Contracting and apprenticeship, there are additional local Yolo County requirement concerning participation in a Joint Apprenticeship Committee and a Health Care Expenditure requirement that apply to the Project pursuant to the County's Procurement Rules. See Section 00 12 00, 0045, 26, 00 45 27, and 00 45 28 for additional information regarding these requirements and the related forms that must be included with your bid.
22. All questions regarding Plans and Specifications and Interpretations or Clarifications for this Invitation for Bid must be entered electronically through the County's electronic solicitation system, **Periscope (formerly Bid Sync)** at <https://www.BidSync.com>. The County Project Manager will respond to all Contractor questions through the Periscope (formerly Bid Sync) Question and Answer section on this website. Questions received less than seven (7) days prior to the date for opening Bids may not be answered. Only questions answered in BidSync or by formal written Addenda posted in Periscope (formerly BidSync) will be binding. Oral and other interpretations or clarifications will be without legal effect.
23. Addenda may also be issued to modify the Bidding Documents as deemed necessary by the County and consultants.
24. Addenda shall be acknowledged on Bid Form by number and shall be part of Contract Documents. Contractor shall be responsible for obtaining all addenda published and complete listing of Addenda may be secured from the Project Manager.



25. Substitutions: Bids shall be based on products and systems specified in Contract Documents or listed by name in Addenda. Contractors and materials suppliers may submit requests for substitutions up to thirty-five (35) days following the Notice of Award.
- (E) Requests for substitutions shall contain sufficient information to assess acceptability of product or system and impact on Project (see Specification Section 01 25 00 for criteria). Insufficient information shall be ground for rejection of substitution.
 - (F) Substitutions may be requested after Contract is signed in accordance with requirements specified in Document 00 70 00 General Conditions and Specifications Section 01 25 00.
 - (G) Substitutions may not be requested during bidding or between bid opening and issuance of the Notice of Award.
26. Bids will be received at County of Yolo, Procurement Division Office 120 West Main Street, Suite G, Woodland, CA 95695 by the County and/or Project Manager who will receive them and time/date them. Bids submitted by mail must be received prior to the opening of bids; the County will not be held responsible for the failure of delivery.
- (H) Envelopes or boxes must be sealed, and marked with name and address of the Bidder, and addressed to:

**Yolo County Procurement Division
120 West Main Street, Suite G
Woodland, CA 95695**

- (I) Mark envelopes:

Yolo County 911 Dispatch Center Tenant Improvement Project

- (J) Envelopes must be submitted by date and time shown in Document 00 12 00, Notice to Bidders.
- (K) Bids must contain the following, fully executed documents:
 - 1) Document 00 41 00 Bid Form: Must be filled in and signed by Bidder.
 - 2) Cash, Cashier's Check or Certified Check, or Document 00 42 00 County of Yolo Bidder's Bond: If submitted, Document 00 42 00 is to be executed by Bidder and its surety.
 - 3) Document 00 43 00 Subcontractors List: If Bidder intends to employ subcontractors, it is necessary to furnish information required on this form, in accordance with instructions contained herein. It is acceptable for the bidder to provide the city and state only on bid day and within 24 hours of the bid due date provide the mailing addresses & phone numbers."



- 4) Document 00 44 00 Bidder Information Sheet
 - 5) Document 00 45 00 List of Successful Projects
 - 6) Document 00 45 10 Non-collusion Declaration: To be subscribed and sworn before a notary public.
 - 7) Document 00 45 26 Joint Apprenticeship Committee Certification with attachment [JAC Letter or other evidence of JAC participation]
 - 8) Document 00 45 27 Statement re No Apprenticeship Violation
 - 9) Document 00 45 28 Acknowledgment Re: Health Care Expenditure Requirement
 - 10) Document 00 45 46 Certification Against Lobbying-reserved
 - 11) Document 00 62 20 Iran Contacting Act
 - 12) Document 00 62 21 Fleet Compliance Certification
27. Envelopes will be opened in public following receipt of bids at 2:15pm on **August 15, 2024**, at Yolo County General Services Department-Procurement Division 120 West Main Street, Ste. G., Woodland, CA.95695.
28. The following documents are to be executed and submitted by apparent low Bidder after Bids have been opened and duly inspected. Failure to properly and timely submit these documents entitles the County to reject the bid as non-responsive.
- (L) Submit the following documents to Procurement by 5:00 p.m. of the TENTH business day following opening and inspection of bids.
- 1) Insurance Certificates and Endorsements required by Document 00 70 00 General Conditions Article 2
- (M) Submit the following documents to Procurement by 5:00 p.m. of the TENTH business day following NOTICE OF AWARD. Award of contract depends upon approval of State Department of Finance, Insurance Certificates and Endorsements, Document 00450 Contractor Information Form, and any required safety submittals.
- 1) Document 00 52 00 Construction Agreement: To be executed by successful Bidder. Submit two (2) copies, each bearing an original signature.
 - 2) Document 00 61 00 Performance Bond: To be executed by successful Bidder and surety.
 - 3) Document 00 62 00 Payment Bond: To be executed by successful bidder and surety.



- (N) Pursuant to Section 1777.5 (d) of the California Labor Code, the Apparent Low Bidder and each of its subcontractors who employ workers in any apprenticeable craft or trade shall employ apprentices in the ratio set forth in Section 1777.5 of the California Labor Code and shall apply to any apprenticeship program in the craft or trade that can provide apprentices to the site of the Project for a certificate approving the contractor (Apparent Low Bidder) and subcontractors under the apprenticeship standards for the employment and training of apprentices in the area or industry affected. The Apparent Low Bidder shall provide documentation of proof of compliance with applicable apprenticeship requirements upon request by the County. This requirement is in addition to the obligation to participate in the County's Joint Apprenticeship Committee requirement and Health Care Expenditure set forth in Section 00 12 00 'Notice to Bidders,' as well as 00 45 26, 00 45 27, and 00 45 28 in this Project Manual.
29. Any bid protest must be submitted in writing to Procurement before 5 p.m. of the FIFTH business day following the posting of the **Intent to Award** on Periscope (formerly Bid Sync).
- (O) The initial protest document must contain a complete statement of the basis for the protest.
- (P) The protest must refer to the specific portions of all documents, which form the basis for the protest.
- (Q) The protest must include the name, address and telephone number of the person representing the protesting party.
- (R) The party filing the protest must concurrently transmit a copy of the initial protest document and any attached documentation to all other parties with a direct financial interest that may be adversely affected by the outcome of the protest. Such parties shall include all other Bidders or proposers who appear to have a reasonable prospect of receiving an award depending upon the outcome of the protest.
- (S) The County will issue a decision on the protest. If the County determines that a protest is frivolous, the party originating the protest may be determined to be irresponsible and that party may be determined to be ineligible for a future contract award.
- (T) The procedure and time limits set forth in this paragraph are mandatory and are the Bidder's sole and exclusive remedy in the event of bid protest and failure to comply with these procedures shall constitute a waiver of any right to further pursue the bid protest, including filing a Government Code Claim or legal proceedings.



30. The County reserves the right, acting in its sole discretion, to reject any or all Bids, including without limitation the right to reject any or all nonconforming, non-responsive, unbalanced or conditional Bids, re-bid, and to reject the Bid of any Bidder if the County believes that it would not be in the best interest of Project to make an award to that Bidder, whether because the Bid is not responsive or the Bidder is unqualified or of doubtful financial ability or fails to meet any other pertinent standard or criteria established by the County. The County also reserves the right, acting in its sole discretion, to waive inconsequential or immaterial deviations not involving price, time or changes in the Work. For purposes of this paragraph, an "unbalanced bid" is one having nominal prices for some work items and enhanced prices for other work items.
31. Discrepancies between the multiplication of units of Work and unit prices will be resolved in favor of the unit prices. Discrepancies between the indicated sum of any column of figures and the correct sum thereof will be resolved in favor of the correct sum. Discrepancies between written words and figures, or words and numerals, will be resolved in favor of the words.
32. In evaluating Bids, the County will consider the qualifications of Bidders, whether or not the Bids comply with the prescribed requirements, unit prices and other data, as may be requested in the Bid Form or prior to the Notice of Award. The County may conduct such investigations as the County deems necessary to assist in the evaluation of any Bid and to establish the responsibility, qualifications and financial ability of Bidders, proposed subcontractors, suppliers and other persons and organizations to perform and furnish the Work in accordance with the Contract Documents to the County's satisfaction within the prescribed time.
33. Special attention is directed to contractors for Covid-19 precautions and requirements during construction. Refer to Section 01 10 00 Summary of Work for description of minimum requirements.
34. Special Requirements:
 - A. The Contractor's workers and equipment shall be limited to the work areas as designated by this contract. In the event the Contractor, his/her employees, or subcontractors fail to adhere to the County's security provisions, the County has the right to deny access to the work site to that employee or subcontractor without an extension of time being granted to the Contractor.
 - B. No smoking shall be allowed on construction site per County's policy.



SECTION 00 41 00

BID FORM

Project: Yolo County 911 Dispatch Center Tenant Improvement Project

1. The undersigned Bidder proposes and agrees, if this Bid is accepted, to enter into an agreement with the County of Yolo ("the County") in the form included in the Contract Documents, Document 00 52 00 Construction Agreement (Contract), to perform and furnish all Work as specified or indicated in the Contract Documents for the Contract Sum and within the Contract Time indicated in this Bid and in accordance with all other terms and conditions of Contract Documents.
2. Bidder accepts all of the terms and conditions of the Contract Documents and the Notice to Bidders, including without limitation, those dealing with the disposition of Bid security. Bidder will sign and submit the Agreement with Bonds and other documents required by Document 00 20 00 Instructions to Bidders, within ten (10) calendar days after receipt of the County's Notice of Award.
3. In submitting this Bid, Bidder represents:
 - (a) Bidder has examined copies of all of the Contract Documents and of the following Addenda (receipt of all of which is hereby acknowledged).

<u>Date</u>	<u>Number</u>
_____	_____
_____	_____
_____	_____
_____	_____

- (b) Bidder has visited the site and has examined thoroughly and understood the nature and extent of the Contract Documents, Work, Site, locality, actual conditions, as built conditions, and all local conditions and federal, state and local laws and regulations that in any manner may affect cost, progress, performance or furnishing of Work or which relate to any aspect of the means, methods, techniques, sequences or procedures of construction to be employed by Bidder and safety precautions and programs incident thereto;



- (c) Bidder has examined thoroughly and understood all reports, drawings and/or reports, available for Bidding purposes and accepts the determination set forth in these documents and Document 00 70 00 General Conditions of the limited extent of the information contained in such reports and drawings upon which the Bidder may be entitled to rely. Bidder agrees that except for the information so identified, Bidder does not and shall not rely on any other information contained in such reports and drawings.
 - (d) Bidder has conducted or obtained and has understood all such examinations, investigations, explorations, tests, reports and studies (in addition to or to supplement those referred to in paragraph 3(c) above) which pertain to the subsurface conditions, as built conditions, Underground Facilities and all other physical conditions at or contiguous to the site or otherwise which may affect the cost, progress, performance or furnishing of Work, as Bidder considers necessary for the performance or furnishing of Work at the Contract Sum, within the Contract Time and in accordance with the other terms and conditions of Contract Documents, including specifically the provisions of the General Conditions; and no additional examinations, investigations, explorations, tests, reports, studies or similar information or data are or will be required by Bidder for such purposes;
 - (e) Bidder has correlated its knowledge and the results of all such observations, examinations, investigations, explorations, tests, reports and studies with the terms and conditions of the Contract Documents.
 - (f) Bidder has given Project Manager prompt written notice of all conflicts, errors, ambiguities or discrepancies that it has discovered in or among the Contract Documents and as built and actual conditions and the written resolution thereof by Project Manager is acceptable to Bidder.
4. Based on the foregoing, Bidder proposes and agrees to fully perform the Work within the time stated and in strict accordance with the Contract Documents for the following sum of money listed in the following Bid Schedule:

(continued next page)



Bid Schedule

Yolo County 911 Dispatch Center Tenant Improvement Project

Contractor / Company: _____

***All line items on Bid Schedule form must be completed for valid bids.** The costs for any work shown or required in the Plans and Specifications, but not specifically identified as a line item are to be included in the related line items and no additional compensation shall be due to Contractor for the performance of the work.

Item Description	Lump Sum Amount
A. MOBILIZATION/DEMOLITION	\$
B. WALLS/CEILING	\$
C. CASEWORK	\$
D. PAINTING	\$
E. MECHANICAL	\$
F. ADA IMPROVEMENTS	\$
a. Building Main Entrance	\$
b. ADA Parking	\$
c. Restroom Improvement:	
Option 1- Detail 4 sheet A2.3	\$
Option 2- Detail 4 sheet A2.3	\$
TOTAL BID with ADA Restroom Improvement Option 1	\$
TOTAL BID with ADA Restroom Improvement Option 1-<u>Written in Words</u>	
TOTAL BID with ADA Restroom Improvement Option 2	\$
TOTAL BID with ADA Restroom Improvement Option 2-<u>Written in Words</u>	



Base Bid Total Price for the Yolo County 911 Dispatch Tenant Improvement Project _____

(written) _____ Dollars

Enclosed find Bidder's Bond, certified check or cashier's check No. _____ of the _____ (Company/Bank), for \$ _____.

Dated this _____ day of _____, 2024

- 5. Subcontractors are listed on the attached document 00 43 00, Subcontractors List.
6. The undersigned understands that the County reserves the right to reject this Bid, but that this Bid shall remain open and shall not be withdrawn for a period of one hundred twenty (120) calendar days from the date prescribed for its opening (to accommodate State financing process).
7. If written notice of the acceptance of this Bid, hereinafter referred to as Notice of Award, is mailed or delivered to the Undersigned within the stipulated time after the date set for the opening of this Bid, or at any other time thereafter before it is withdrawn, the undersigned will execute and deliver the documents required by Document 00 20 00 Instructions to Bidders including, but not limited to, Document 00 52 00 Construction Agreement, Document 00 61 00 Performance Bond, and Document 00 62 00 Payment Bond and Escrow Bid Documents, all within ten (10) calendar days after personal delivery or after receipt in the mails of the Notice of Award.
8. Notice of Award or request for additional information may be addressed to the undersigned at the address set forth below.
9. The undersigned herewith encloses a cash, cashier's check, certified check or corporate surety bond in the amount of ten percent (10%) of the total of Bid Items and made payable to: County of Yolo and is subject to all conditions imposed by law.
10. The undersigned agrees to commence work under this Contract on the date established and to complete all work within the time specified in Document 00 52 00 (Construction Agreement).
11. The undersigned agrees that, in accordance with Document 00 70 00 General Conditions liquidated damages for failure to complete all work in the contract within the time specified are as set forth in Document 00 52 00 (Construction Agreement).
12. The undersigned herewith encloses the completed Bidder's Bond - 00 42 00.
13. The undersigned herewith encloses the completed Subcontractors List - 00 43 00.
14. The undersigned herewith encloses the completed Bidder Information Sheet - 00 44 00.
15. The undersigned herewith encloses the completed List of Successful Projects form - 00 45 00.



16. The undersigned herewith encloses the completed Non-Collusion Declaration – 00 45 10.
17. The undersigned herewith encloses the completed Joint Apprenticeship Committee Certification– 00 45 26.
18. The undersigned herewith encloses the completed Statement re No Apprenticeship Violation – 00 45 27.
19. The undersigned herewith encloses the completed Acknowledgment re: Health Care Expenditure Requirement – 00 45 28.
20. The undersigned herewith encloses the completed Certification Against Lobbying – 00 45 46. (reserved)
21. The undersigned herewith encloses the completed Iran Contracting Act-00 62 20. (reserved).
22. The undersigned herewith encloses the completed Document 00 62 21 Fleet Compliance Certification.

REMAINDER OF PAGE INTENTIONALLY LEFT BLANK
////////////////////////////////////



23) The names of all persons interested in the foregoing Bid as principals are:

(IMPORTANT NOTICE: If Bidder or other interested person is a corporation, give the legal name of corporation, state where incorporated, and names of president and secretary thereof; if a partnership, give name of the firm and names of all individual co-partners composing the firm; if Bidder or other interested person is an individual, give first and last names in full).

Name of Bidder:

Legal Name of Corporation or Firm

CA Contractor's License No.

DIR Registration No.

Business Address

Email Address

Telephone Number

Date of Bid

Signature of Bidder (Authorized to sign contracts on behalf of the Corporation or Firm)

Printed Name

Title



SECTION 00 42 00

COUNTY OF YOLO BIDDER'S BOND

We, _____ as Principal, and
_____ as Surety, are bound unto THE COUNTY
OF YOLO as Owner (Obligee), in the penal sum of ten percent (10%) of the total amount of the bid of
the Principal submitted to the Obligee for the work described below, for the payment of which sum we
bind ourselves, jointly and severally,

THE CONDITION OF THIS OBLIGATION IS SUCH, THAT:

WHEREAS, the Principal is submitting a bid to the Obligee, for the **Yolo County 911
Dispatch Center Tenant Improvement Project** for which bids are to be opened in public at the
**General Services Department, Procurement Division 120 West Main Street, Ste G, Woodland,
CA 95695.**

NOW THEREFORE, if Principal is awarded the Contract and, within the time and manner
required under the specifications, after the prescribed forms are presented to him for signature,
enters into a written contract, in the prescribed form, in accordance with the bid, and files two
bonds with the Obligee, one to guarantee faithful performance of the contract and the other to
guarantee payment for labor and materials, as required by law, then this obligation shall be null and
void; otherwise it shall remain in full force.

In the event suit is brought upon this bond by the Obligee and judgment is recovered, the
Surety shall pay all costs incurred by the Obligee in such suit, including reasonable attorney's fees to be
fixed by the Court.

Dated: _____

Principal

Surety

By: _____
Attorney-in-Fact

ADDRESS OF SURETY FOR SERVICE OF NOTICE:

NOTE: Signature of those executing for the Surety shall be properly acknowledged and accompanied by a Certificate of
Acknowledgement



SECTION 00 44 00

BIDDER INFORMATION SHEET

The Bidder must check one of the following classifications that fit its type of business organization and furnish all information required under that classification.

Please type or print your answers.

Attach a copy of license(s) upon which you intend to rely.

() **BIDDER IS A CORPORATION**

The full name of the corporation as it appears on the State Contractor's License is:

Corporation is incorporated in the State of:

() **BIDDER IS AN INDIVIDUAL**

Bidder's name as it appears on State Contractor's License is:

() **BIDDER IS A PARTNERSHIP**

Bidder's firm name, individual or partnership, as it appears on State Contractor's License is:

The full names of all partners as they appear on State Contractor's License are:

County in which any Certificate of Doing Business Under Fictitious Name is filed – (If none, so state):

Accompanying this proposal is _____ (NOTICE: INSERT THE WORDS "CASH (\$_____)", "CASHIER'S CHECK", "CERTIFIED CHECK", OR "BIDDER'S BOND", AS THE CASE MAY BE) in amount equal to at least ten (10) percent of the total of the Bid.



The names of all persons interested in the forgoing proposal as principals are as follows:

IMPORTANT NOTICE: If the Bidder or other interested person is a corporation, state legal name of corporation, also names of the president, secretary, treasurer, and executive officer thereof; if a partnership, state name of partnership, also names of all individual partners; if Bidder or other interested person is an individual, state first and last names in full.

Licensed in accordance with an act providing for the registration of contractors,

License No. _____ Classifications(s) _____
(A copy of the afore-referenced license must be supplied at Notice of Award.)

ADDENDA: This Proposal is submitted with respect to the changes to the Contract included in addenda number/s

(Fill in addenda numbers if addendas have been received and insert, in this proposal, any Engineer's Estimate sheets that were received as part of the addenda)

CERTIFICATION OF BIDDER FOR PROPOSAL:

By my signature on this Proposal I certify, under penalty of perjury under the laws of the State of California, that the foregoing questionnaire and statements of Public Contract Code are true and correct. By my signature on this proposal I further certify, under penalty of perjury under the laws of the State of California and the United States of America, that the Non-collusion Declaration required by Public Contract Code Section 7106 and Part 24 Debarment and Suspension Certification are true and correct.

The person or persons executing this proposal on behalf of a corporation or a member of partnership, shall be prepared to demonstrate by resolution, article, or otherwise, that such person is or that such persons are appropriately authorized to act in these regards for such corporation or partnership. Such authority shall be demonstrated to the satisfaction of the County of Yolo.

If the signature is by an agent other than an officer of a corporation or a member of a partnership, a power of attorney authorizing said act by the agent on behalf of his principal shall be submitted with the bid forms, otherwise the Bid may be disregarded as irregular and unauthorized.

The Bidder's execution on the signature portion of this Proposal shall constitute an endorsement and execution of those affidavits, declarations and certifications which are of this Proposal.

Executed this _____ day of _____ at _____,
California.

Sign Here: _____

by

Name and Title of Bidder



SECTION 00 45 00

LIST OF SUCCESSFUL PROJECTS

Bidders must have experience in remodeling projects and bidders must list below a minimum of five similar projects of not less than 50% of the total work scope of this project and within the last eight years.

Bidder name: _____

	Project Location	Project Description	Contract Dollar Amount	Name and Phone # of Owner's Representative
1				
2				
3				
4				
5				



SECTION 00 45 10

NON-COLLUSION DECLARATION

**Non-Collusion Declaration To Be Executed By Bidder and Submitted with Bid
(Public Contract Code Section 7106)**

State of California)

) ss.

County of Yolo)

The undersigned declares:

I am the _____ of _____, the party making the foregoing bid.

The bid is not made in the interest of, or on behalf of, any undisclosed person, partnership, company, association, organization, or corporation. The bid is genuine and not collusive or sham. The bidder has not directly or indirectly induced or solicited any other bidder to put in a false or sham bid. The bidder has not directly or indirectly colluded, conspired, connived, or agreed with any bidder or anyone else to put in a sham bid, or to refrain from bidding. The bidder has not in any manner, directly or indirectly, sought by agreement, communication, or conference with anyone to fix the bid price of the bidder or any other bidder, or to fix any overhead, profit, or cost element of the bid price, or of that of any other bidder. All statements contained in the bid are true. The bidder has not, directly or indirectly, submitted his or her bid price or any breakdown thereof, or the contents thereof, or divulged information or data relative thereto, to any corporation, partnership, company, association, organization, bid depository, or to any member or agent thereof, to effectuate a collusive or sham bid, and has not paid, and will not pay, any person or entity for such purpose.

Any person executing this declaration on behalf of a bidder that is a corporation, partnership, joint venture, limited liability company, limited liability partnership, or any other entity, hereby represents that he or she has full power to execute, and does execute, this declaration on behalf of the bidder.

I declare under penalty of perjury under the laws of the State of California that the foregoing is true and correct and that this declaration is executed on _____ [date], at _____ [city], _____ [state].

Name of Bidder _____

Signature _____

Name and Title _____

Dated _____

Note: Bidders are cautioned that making a false certification may subject the bidder to criminal prosecution



SECTION 00 45 26

JOINT APPRENTICESHIP COMMITTEE PARTICIPATION CERTIFICATION

The County has adopted a Joint Apprenticeship Committee (JAC) participation requirement for certain public projects estimated to cost more than one-million dollars (\$1,000,000). A JAC means an apprenticeship program comprised of an equal number of employer and employee representatives approved by the State of California Division of Apprenticeship Standards. This JAC requirement is in addition to the apprenticeship requirements of the Prevailing Wage Laws.

To satisfy the County's JAC participation requirement, Contractors must submit evidence satisfactory to the Procurement Manager or the Procurement Manager's designee that they participate in a JAC by being a signatory to a JAC or employ registered apprentices dispatched by a JAC. Such evidence may be in the form of a signed letter from a JAC confirming the Contractor is a signatory to a JAC or has hired registered apprentices who are active participants of a JAC.

By signing below, Contractor acknowledges the County's JAC participation requirement and certifies that it satisfies this requirement. Failure to submit this form and attach evidence of compliance with this requirement shall result in a determination that the bid is non-responsive.

Name of Contractor Submitting Bid: _____

Signature: _____

Name and Title: _____

Date: _____

Occupation(s)/Trade(s)/Craft(s):

Name of JAC: _____

Include Attachment – JAC Letter or other evidence of JAC participation.



SECTION 00 45 27

STATEMENT RE NO APPRENTICESHIP VIOLATION

I am the _____ of _____
[Title] [Contractor]

and I am authorized to make this statement on Contractor's behalf.

During the past three (3) years, Contractor has not been found in violation of any provision of State or local apprenticeship laws or regulations.

Signature: _____

Printed Name: _____

Date: _____

REMAINDER OF THIS PAGE INTENTIONALLY LEFT BLANK

////////////////////////////////////



SECTION 00 45 28

ACKNOWLEDGMENT RE: HEALTH CARE EXPENDITURE REQUIREMENT

As set forth in the County's Policy on Procurement, the County has adopted the following requirement regarding Health Care Expenditures for certain public projects estimated to cost more than one million dollars (\$1,000,000):

Each Contractor with construction craft employees shall make health care expenditures for each such employee in an amount per hour worked on the Covered Project equivalent to at least the hourly pro rata cost of a Covered California Platinum level plan for two 40-year-old adults and two dependents 0 to 14 years of age for the Covered California rating area in which the development is located. Qualifying expenditures shall be credited toward compliance with prevailing wage payment requirements up to the amount determined by the Director of Industrial Relations pursuant to Sections 1773 and 1773.9 of the Labor Code. Health care expenditures in excess of that amount shall not be so credited. "Health care expenditures" include contributions under Sections 501(c) or (d) or 401(a) of the Internal Revenue Code and payments toward "medical care" as defined under Section 213(d)(1) of the Internal Revenue Code. A Contractor that is signatory to a valid collective bargaining agreement that requires payment of at least the prevailing wage, participation in a joint labor-management apprenticeship program, and the provision of health care payments for all construction craft employees shall be deemed in compliance. A Contractor without construction craft employees shall show a contractual obligation that its subcontractors comply with this paragraph.

The Project is a "Covered Project" and subject to this health care expenditure requirement.

By signing below, Contractor acknowledges that Contractor has read and will comply with this health care expenditure requirement or, alternatively, that Contractor is a signatory to a valid collective bargaining agreement, which requires payment of at least the prevailing wage, participation in join labor-management apprenticeship program, and the provision of health care payments for all construction craft employees.

Failure to submit this acknowledgment form shall result in a determination that the bid is non-responsive.

Name of Contractor Submitting Bid: _____

Signature: _____

Name and Title: _____

Date: _____



SECTION 00 51 00

NOTICE OF AWARD

Dated: xxxxxxxx, 2024

TO: xxxxxxxxxxxxxxxxxxxxxxxxxxxxxxxx
xxxxxxxxxxxxxxxxxxxxxxxxxxxxxxxxxxxx

COUNTY OF YOLO PROJECT:
Bid No. **01**

ADDRESS: xxxxxxxxxxxxxxxx
xxxxxxxxxxxxxxxxxxxx

PROJECT: Yolo County 911 Dispatch Center Tenant Improvement Project .

COUNTY OF YOLO CONTRACT

CONTRACT FOR: Yolo County 911 Dispatch Center Tenant Improvement Project.

The Contract Price of your contract is xxxxxxxxxxxxxxxxxxxxxxxxxxxxxxxx Dollars (\$xxxxxxxxxxxx).

Two copies of each of the proposed Contract Documents (except Drawings) accompany this Notice of Award. Three sets of the Drawings will be delivered separately or otherwise made available to you immediately.

Upon receipt of this Notice of Award, you and each of your subcontractors who employ workers in any apprenticeship craft or trade, shall apply to the joint apprenticeship committee administering the apprenticeship standards of the craft or trade for a certificate approving you and your subcontractors under the apprenticeship standards for the employment and training of apprentices, pursuant to section 1777.5 of the California Labor Code.

Upon commencement of the work, you and each of your subcontractors shall certify and make available for inspection payroll records on forms provided by the Division of Labor Standards Enforcement, pursuant to section 1776 of the California Labor Code.

You must comply with the following conditions precedent within ten calendar days of the date of this Notice of Award, that is by xxxxxxxxxxxxxxxxxxxxxxxxxx, 2024.

1. You must deliver to the County two fully executed counterparts of the Construction Agreement (Document 00 52 00). Each of the Contract Documents must bear your signature on the cover page.
2. You must deliver to the County the Contract Performance Bond (Document 00 61 00) and Payment Bond (Document 00 62 00).
3. You must deliver to the County Certificates of Insurance for amounts specified.



Failure to comply with these conditions within the time specified will entitle the County to consider your bid abandoned, to annul this Notice of Award and to declare your Bid Security forfeited.

Within ten days after you comply with those conditions, the County will return to you one fully signed counterpart of the Contract with the Contract Documents attached.

County of Yolo

BY: _____

Chris Rice
Project Manager
Yolo County General Services Department

REMAINDER OF PAGE INTENTIONALLY LEFT BLANK

////////////////////////////////////



SECTION 00 52 00

COUNTY OF YOLO, CALIFORNIA

**CONSTRUCTION AGREEMENT FOR
Yolo County 911 Dispatch Center Tenant Improvement Project
35 N Cottonwood Street, Woodland, CA 95695**

CONTRACT NO. _____

This Agreement for Construction (“Agreement” or “Contract”) is between _____, a California _____ (“Contractor”), and the County of Yolo (“County”), a political subdivision of the State of California.

1. SCOPE OF WORK. Contractor shall furnish all labor, services, transportation, materials, equipment, parts, and supplies necessary for the Yolo County 911 Dispatch Center Tenant Improvement Project (“**the Project**”) in strict accordance with the Project plans and specifications and Contract Documents. Contractor shall complete the Project per the Bid Schedule, not to exceed \$__ (“Contract Price”).

2. CONTRACT DOCUMENTS. The following documents defined as the “Contract Documents” in Section 1.12 of the General Conditions, are incorporated as if fully set forth herein by this reference and comprise the entire Agreement between the County and Contractor concerning the Project.

- Proposal Response, including all required forms
- Subcontractor List
- Project Manual, Vol. I, Bidding and Contracting Requirements
- Project Manual, Vol. II, Technical Specifications and Drawings
- Performance Bond and Payment Bond
- General Conditions
- Notice to Bidders
- Notice to Proceed
- Project Plans and Specifications
- Addendas
- Change Orders Issued by the County

All of the Contract Documents are intended to be complementary. Work required by one of the Contract Documents and not by others shall be done as if required by all. In the event of a conflict, the various Contract Documents will be given effect in the order set forth in the General Conditions (Sections 4.02 and 20.08). In the event of any remaining conflict, the provision that requires the highest level of performance from Contractor for the County’s benefit shall prevail.



3. CONDUCT OF WORK, CONTRACT ADMINISTRATOR. Contractor shall perform the services described in the Contract Documents in a in a good, workmanlike and substantial manner and to the satisfaction of the County and in a manner that causes the least possible inconvenience to County and the public and safeguards persons and property from any dangerous activities or conditions conducted or created by Contractor. County's Chief Deputy County Administration Officer shall administer this Agreement for County. County's Board of Supervisors may designate a different person to serve as Contract Administrator by giving advance written notice to Contractor.

(a) **Work Schedule.** Unless otherwise agreed pursuant to Section 3.01 of the General Conditions, Contractor shall begin work within ten (10) calendar days after receiving the Contract Administrator's Notice to Proceed and shall complete the work within **60 calendar days** after receiving that notice, followed by a 90-day maintenance period. This work must be complete, operational, and be accepted by the County for its intended use for this milestone to be deemed complete.

(b) **Liquidated Damages.** Contractor shall pay County \$400.00 a day liquidated damages for each day's delay (excluding Saturdays, Sundays, and County observed holidays) in completing the work beyond the time specified for completion of work. All other aspects of the payment of such damages shall be governed by Section 3.12 of the General Conditions and other relevant provisions thereof. The assessment of liquidated damages is not a penalty but considered to be a reasonable estimate of the amount of damages County will suffer by delay in completion of the Project. The County is entitled to set off the amount of liquidated damages assessed against any payments otherwise due to Contractor, including, but not limited to, setoff against release of retention. If the total amount of liquidated damages assessed exceeds the amount of unreleased retention, County is entitled to recover the balance from Contractor or its sureties. Use of the Project in whole or in part prior to substantial completion, shall not operate as a waiver of County's right to assess liquidated damages.

4. INDEMNIFICATION. With the exception that this section shall in no event be construed to require indemnification by Contractor to a greater extent than permitted under the public policy of the State of California, Contractor shall provide indemnification and defense of the County as set forth in the General Conditions (see sections 2.05 and 2.06 of the General Conditions) and Section 00 62 10 of the Project Manual.

Responsibility for such defense and indemnity obligations shall survive the termination or completion of this Agreement for the full period of time allowed by law. The defense and indemnification obligations of this Agreement are undertaken in addition to, and shall not in any way be limited by, the insurance obligations contained in this Agreement. In providing any defense under the Contract Documents, Contractor shall use counsel reasonably acceptable to the County.

5. COMPENSATION; PREVAILING WAGE. The County shall pay to the Contractor as full compensation for the performance of this Agreement the Contract Price, subject to any additions or deductions as provided in the Contract Documents. All matters of compensation and payment shall be governed by the General Conditions, including but not limited to Article 25 thereof, provided, however that the total compensation to be paid by County to Contractor shall not



exceed the Contract Price. The statement of prevailing wages appearing in the General Prevailing Wage Rate Determinations of the Director of the State of California Department of Industrial Relations are incorporated herein by reference. When two rates differ for similar kinds of labor, Contractor shall pay not less than the higher rate. Contractor shall bear all risks of payment or non-payment of prevailing wages under California law, and Contractor hereby agrees to defend, indemnify, and hold the County, its officials, officers, employees, agents and volunteers, free and harmless from any claim or liability arising out of any failure or alleged failure to comply with the prevailing wage laws.

6. INSURANCE. Contractor shall maintain the insurance required by the General Conditions and the following insurance while performing the work covered by this Agreement. The comprehensive general liability insurance shall include broad form property damage insurance.

(a) Minimum Coverages (as applicable) - Insurance coverage shall be with limits not less than the following:

1. **Commercial General Liability** Occurrence form Insurance policy (ISO CG 00 01 or equivalent) covering all operations by or on behalf of Contractor, including coverage for:

- a) Premises and Operations
- b) Products and completed Operations
- c) Contractual Liability insuring the obligations assumed by Contractor in this agreement or Blanket Contractual Liability Coverage
- d) Broad Form Property Damage (including Completed Operations)
- e) Explosion, Collapse, and Underground Hazards
- f) Personal Injury Liability

Limits of liability shall be not less than:

\$5,000,000 each occurrence (combined single limit for bodily injury and property damage)

\$5,000,000 for Personal Injury Liability

\$5,000,000 for Products Completed Operations

\$10,000,000 General Aggregate

If the policy does not have an endorsement providing that the General Aggregate Limit applies separately, or if defense costs are included in the aggregate limits, then the required aggregate limits shall be \$10,000,000.

2. **Automobile Liability** – Insurance policy (ISO CA 00 01) covering Bodily Injury, Property Damage and contractual Liability coverage for “Any Auto” which includes coverage for any owned, hired, borrowed and non-owned automobile, trailer, and equipment coverage, with limits no less than \$1,000,000 occurrence (per accident for bodily injury and property damage) and \$2,000,000 policy aggregate.



3. **Workers' Compensation** – Statutory Limits/**Employers' Liability** – No less than \$1,000,000 per accident for bodily injury or disease.
4. **Builder's Risk** – (Course of Construction) insurance utilizing an “All Risk” (Special Perils) coverage form, with limits equal to the completed value of the project and no coinsurance penalty provisions.
5. **Contractor's Pollution Legal Liability Insurance** – Limits of no less than \$2,000,000 per occurrence or claim, and \$2,000,000 policy aggregate.

(b) The County, its officers, agents, employees and volunteers shall be named as additional insured on all but the workers' compensation and professional liability coverages. [NOTE: Evidence of additional insured may be needed as a separate endorsement due to wording on the certificate negating any additional writing in the description box.] It shall be a requirement under this agreement that any

available insurance proceeds broader than or in excess of the specified minimum Insurance coverage requirements and/or limits shall be available to the Additional Insured. Furthermore, the requirements for coverage and limits shall be (1) the minimum coverage and limits specified in this Agreement; or (2) the broader coverage and maximum limits of coverage of any Insurance policy or proceeds available to the named Insured; whichever is greater.

1. The Additional Insured coverage under the Contractor's policy shall be “primary and non-contributory” and will not seek contribution from the County's insurance or self-insurance and shall be at least as broad as CG 20 01 04 13.
2. The limits of Insurance required in this agreement may be satisfied by a combination of primary and umbrella or excess Insurance. Any umbrella or excess Insurance shall contain or be endorsed to contain a provision that such coverage shall also apply on a primary and non-contributory basis for the benefit of the County of Yolo (if agreed to in a written contract or agreement) before the County's own Insurance or self-insurance shall be called upon to protect it as a named insured.
3. Said policies shall remain in force through the life of this Agreement and, with the exception of professional liability coverage, shall be payable on a “per occurrence” basis unless the County Risk Manager specifically consents in writing to a “claims made” basis. For all “claims made” coverage, in the event that the Contractor changes insurance carriers Contractor shall purchase “tail” coverage covering the term of this Agreement and not less than three years thereafter. Proof of such “tail” coverage shall be required at any time that the Contractor changes to a new carrier prior to receipt of any payments due.



4. The Contractor shall declare all aggregate limits on the coverage before commencing performance of this Agreement, and the County's Risk Manager reserves the right to require higher aggregate limits to ensure that the coverage limits required for this Agreement as set forth above are available throughout the performance of this Agreement.
 5. Any deductibles or self-insured retentions must be declared to and are subject to the approval of the County Risk Manager. All self-insured retentions (SIR) must be disclosed to Risk Management for approval and shall not reduce the limits of liability. Policies containing any SIR provision shall provide or be endorsed to provide that the SIR may be satisfied either by the named Insured or Yolo County.
 6. Each insurance policy shall be endorsed to state that coverage shall not be suspended, voided, canceled by either party, reduced in coverage or in limits except after thirty (30) days' prior written notice by certified mail, return receipt requested, has been given to the Director (ten (10) days for delinquent insurance premium payments).
 7. Insurance is to be placed with insurers with a current A.M. Best's rating of no less than A:VII, unless otherwise approved by the County Risk Manager.
 8. The policies shall cover all activities of Contractor, its officers, employees, agents and volunteers arising out of or in connection with this Agreement.
 9. For any claims relating to this Agreement, the Contractor's insurance coverage shall be primary, including as respects the County, its officers, agents, employees and volunteers. Any insurance maintained by the County shall apply in excess of, and not contribute with, insurance provided by Contractor's liability insurance policy.
 10. The insurer shall waive all rights of subrogation against the County, its officers, employees, agents and volunteers.
- (c) Prior to commencing services pursuant to this Agreement, Contractor shall furnish the County with original endorsements reflecting coverage required by this Agreement. The endorsements are to be signed by a person authorized by that insurer to bind coverage on its behalf. All endorsements are to be received by, and are subject to the approval of, the County Risk Manager before work commences. Upon County's request, Contractor shall provide complete, certified copies of all required insurance policies, including endorsements reflecting the coverage required by these specifications.
- (d) During the term of this Agreement, Contractor shall furnish the County with original endorsements reflecting renewals, changes in insurance companies and any other documents reflecting the maintenance of the required coverage throughout the entire term of this Agreement. The endorsements are to be signed by a person authorized



_____Yolo County 911 Dispatch Center Tenant Improvement Project

by that insurer to bind coverage on its behalf. Upon County's request, Contractor shall provide complete, certified copies of all required insurance policies, including endorsements reflecting the coverage required by these specifications. Yolo County reserves the right to obtain a full certified copy of any Insurance policy and endorsements. Failure to exercise this right shall not constitute a waiver of right to exercise later.

- (e) Contractor agrees to include with all Subcontractors in their subcontract the same requirements and provisions of this agreement including the indemnity and Insurance requirements to the extent they apply to the scope of the Subcontractor's work. Subcontractors hired by Contractor agree to be bound to Contractor and the County of Yolo in the same manner and to the same extent as Contractor is bound to the County of Yolo under the Contract Documents. Subcontractor further agrees to include these same provisions with any Sub-subcontractor. A copy of the Owner Contract Document Indemnity and Insurance provisions will be furnished to the Subcontractor upon request. Contractor shall require all Subcontractors to provide a valid certificate of insurance and the required endorsements included in the agreement prior to commencement of any work and Contractor will provide proof of compliance to the County of Yolo.
- (f) Contractor shall maintain insurance as required by this contract to the fullest amount allowed by law and shall maintain insurance for a minimum of five years following the completion of this project. In the event Contractor fails to obtain or maintain completed operations coverage as required by this agreement, the County at its sole discretion may purchase the coverage required and the cost will be paid by Contractor.

7. COMPLIANCE WITH LAWS.

- (a) Contractor shall comply with all relevant federal, state, and local statutes, regulations, ordinances, rules, orders, and other laws in effect when performing the services required by this Agreement, all as set forth in the General Conditions (including but not limited to Article 20 thereof), and including, but not limited to, the provisions of the California Labor Code and California Public Contract Code that are applicable to this Project.
- (b) By its signature hereunder, Contractor further certifies that it is aware of the provisions of Section 3700 of the Labor Code et seq. which require every employer to be insured against liability for worker's compensation or to undertake self-insurance in accordance with the provisions of that code, and Contractor will comply with such provisions before commencing the performance of the work of this contract.
- (c) Contractor further represents and warrants that it is eligible to work on the Project pursuant to Labor Code Sections 1777.1 and 1777.7 and other applicable provisions of law. Further, Contractor acknowledges that it is prohibited from performing work on the Project with a subcontractor who is ineligible to perform work on public works project pursuant to Labor Code Sections 1777.1 and 1777.7.

8. INDEPENDENT CONTRACTOR. While performing the services required by this Agreement for Construction, Contractor shall act as an independent contractor, not as an employee of County, and thus shall be subject to the direction and control of County only for the final result. Contractor shall be solely responsible for paying all required employment taxes and for meeting all employment obligations related to its performance of the services, including but not limited to



payment of worker's compensation, liability insurance, social security taxes (i.e., FICA), and tax withholding. Moreover, Contractor shall indemnify, defend (upon County's written request), and protect County from any liability County may incur to federal or state governments for such taxes and obligations. This Agreement does not entitle Contractor or its officers, employees, subcontractors, or agents to vacation pay, sick leave, retirement benefits, disability or unemployment insurance, or employee benefits of any kind from County.

9. INSPECTIONS. All inspections and any remedial action required in response thereto shall be governed by the General Conditions, including but not limited to Article 18 thereof.

10. PERFORMANCE AND PAYMENT BONDS. Within the time set forth in the Proposal and before performing any services pursuant to this Agreement, Contractor shall provide to County the bonds required by the General Conditions, including but not limited to Article 2 thereof. All other matters relating to bonds shall be governed by the General Conditions.

11. TERM OF AGREEMENT; EARLY TERMINATION. The term and termination of this Agreement shall be governed by the General Conditions, including but not limited to Article 27 thereof.

12. GUARANTY. Guarantees and warranties shall be governed by the General Conditions, including but not limited to Article 26 thereof.

13. AUDIT PROVISIONS. Contractor's records which shall include but not limited to accounting records, subcontract files, correspondence, change order files, and any other supporting evidence necessary to substantiate charges relating to this contract (all the foregoing hereinafter referred to as "records") shall be open to inspection and subject to audit and/or reproduction, during normal working hours, by County's agent or its authorized representative to the extent necessary to adequately permit evaluation and verification of any invoices, payments, or claims submitted by the contractor or any of his payees pursuant to the execution of this Agreement. For the purpose of such audits, inspections, examination, and evaluations, the County's agent or authorized representative shall have access to said records from the effective date of this Agreement, for the duration of the work, and until six years after the date of final payment by County to Contractor pursuant to this Agreement.



14. PROCEDURE FOR RESOLVING CLAIMS.

Contractor shall timely comply with any and all requirement of the Contract Documents pertaining to notices and requests for changes to the Contract Time or Contract Price as a prerequisite to filing any claim governed by this Section. The failure to timely submit a notice of delay or notice of change, or to timely request a change to the time for completion or Contractor's compensation, or to timely provide any other notice or request required herein shall constitute a waiver of the right to further pursue the claim under the Contract or at law. This claim resolution procedure shall control over any conflicting claim or dispute resolution procedure in the Contract Documents.

(a) **Intent.** Effective January 1, 1991, Section 20104 et seq., of the California Public Contract Code prescribes a process utilizing informal conferences, non-binding judicial supervised mediation, and judicial arbitration to resolve disputes on construction claims of \$375,000 or less. Effective January 1, 2017, Section 9204 of the Public Contract Code prescribes a process for negotiation and mediation to resolve disputes on construction claims. The intent of this Section is to implement Sections 20104 et seq. and Section 9204 of the California Public Contract Code. This Section shall be construed to be consistent with all applicable law, including but not limited to these statutes.

(b) **Claims.** For purposes of this Section, "Claim" means a separate demand by the Contractor for:

- i. An adjustment to the time for completion including, without limitation, for relief from damages or penalties for delay assessed by the County;
- ii. Payment by the County of money or damages arising from Work done by or on behalf of the Contractor pursuant to the Contract, payment for which is not otherwise expressly provided or to which the Contractor is not otherwise entitled; or
- iii. An amount the payment of which is disputed by the County.

A "Claim" does not include any demand for payment for which the CONTRACTOR has failed to provide notice, request a Contract Change Order, or otherwise failed to follow any procedures contained in the Contract Documents.

(c) **Filing Claims.** Claims governed by this Section may not be filed unless and until the Contractor completes any and all requirements of the Contract Documents pertaining to notices and requests for changes to the Contract Price or Contract Time, and Contractor's request for a change has been denied in whole or in part. Claims governed by this Section must be filed no later than fourteen (14) days after a request for change has been denied in whole or in part or after any other event giving rise to the Claim. The Claim shall be submitted in writing to the County and shall include on its first page the following words in



16 point capital font: “THIS IS A CLAIM.” The Claim shall include all information and documents necessary to substantiate the Claim, including but not limited to those identified below. Nothing in this Section is intended to extend the time limit or supersede notice requirements otherwise provided by Contract Documents. Failure to follow such contractual requirements shall bar any Claims or subsequent proceedings for compensation or payment thereon.

(d) Documentation. The Contractor shall submit all Claims in the following format:

- i. Summary description of Claim including basis of entitlement, merit and amount of time or money requested, with specific reference to the Contract Documents provisions pursuant to which the Claim is made
- ii. List of documents relating to Claim:
 - i. Specifications
 - ii. Drawings
 - iii. Clarifications (Requests for Information)
 - iv. Schedules
 - v. Other
- iii. Chronology of events and correspondence
- iv. Narrative analysis of Claim merit
- v. Analysis of Claim cost, including calculations and supporting documents
- vi. Time impact analysis in the form required by the Contract Documents, if the Contract Documents do not require a particular format, CPM format, if an adjustment of the Contract Time is requested.

(e) County’s Response. Upon receipt of a Claim pursuant to this Section, the County shall conduct a reasonable review of the Claim and, within a period not to exceed forty-five (45) days, shall provide the Contractor a written statement identifying what portion of the Claim is disputed and what portion is undisputed. Any payment due on an undisputed portion of the Claim will be processed and made within sixty (60) days after the County issues its written statement.

- i. If the County needs approval from its governing body to provide the Contractor a written statement identifying the disputed portion and the undisputed portion of the Claim, and the County’s governing body does not meet within the forty-five (45) days or within the mutually agreed to extension of time following receipt of a Claim sent by registered mail or certified mail, return receipt requested, the County shall have up to three (3) days following the next duly publicly noticed meeting of the County’s governing body after the forty-five (45) day period, or extension, expires to provide the Contractor a written statement identifying the disputed portion and the undisputed portion.
- ii. Within thirty (30) days of receipt of a Claim, the County may request in writing additional documentation supporting the Claim or relating to defenses or Claims the County may have against the Contractor. If additional information is thereafter required, it shall be requested and provided pursuant to this subdivision, upon mutual



agreement of the County and the Contractor. The County's written response to the Claim, as further documented, shall be submitted to the Contractor within thirty (30) days (if the Claim is less than \$50,000, within fifteen (15) days after receipt of the further documentation, or within a period of time no greater than that taken by the Contractor in producing the additional information or requested documentation, whichever is greater.

- (f) **Meet and Confer.** If the Contractor disputes the County's written response, or the County fails to respond within the time prescribed, the Contractor may so notify the County, in writing, either within fifteen (15) DAYS of receipt of the County's response or within fifteen (15) days of the County's failure to respond within the time prescribed, respectively, and demand in writing an informal conference to meet and confer for settlement of the issues in dispute. Upon receipt of a demand, the County shall schedule a meet and confer conference within thirty (30) days for settlement of the dispute.
- (g) **Mediation.** Within ten (10) business days following the conclusion of the meet and confer conference, if the Claim or any portion of the Claim remains in dispute, the County shall provide the Contractor a written statement identifying the portion of the Claim that remains in dispute and the portion that is undisputed. Any payment due on an undisputed portion of the Claim shall be processed and made within sixty (60) days after the County issues its written statement. Any disputed portion of the Claim, as identified by the Contractor in writing, shall be submitted to nonbinding mediation, with the County and the Contractor sharing the associated costs equally. The County and Contractor shall mutually agree to a mediator within ten (10) business days after the disputed portion of the Claim has been identified in writing, unless the parties agree to select a mediator at a later time.
- i. If the parties cannot agree upon a mediator, each party shall select a mediator and those mediators shall select a qualified neutral third party to mediate with regard to the disputed portion of the Claim. Each party shall bear the fees and costs charged by its respective mediator in connection with the selection of the neutral mediator.
 - ii. For purposes of this Section, mediation includes any nonbinding process, including, but not limited to, neutral evaluation or a dispute review board, in which an independent third party or board assists the parties in dispute resolution through negotiation or by issuance of an evaluation. Any mediation utilized shall conform to the timeframes in this Section.
 - iii. Unless otherwise agreed to by the County and the Contractor in writing, the mediation conducted pursuant to this Section shall excuse any further obligation under Section 20104.4 to mediate after litigation has been commenced.
 - iv. The mediation shall be held no earlier than the date the Contractor completes the Work or the date that the Contractor last performs Work, whichever is earlier. All unresolved Claims shall be considered jointly in a single mediation, unless a new unrelated Claim arises after mediation is completed.
- (h) **Procedures After Mediation.** If following the mediation, the Claim or any portion remains in dispute, the Contractor must file a Claim pursuant to Chapter 1 (commencing with



Section 900) and Chapter 2 (commencing with Section 910) of Part 3 of Division 3.6 of Title 1 of the Government Code prior to initiating litigation. For purposes of those provisions, the running of the period of time within which a Claim must be filed shall be tolled from the time the Contractor submits his or her written Claim pursuant to subdivision (a) until the time the Claim is denied, including any period of time utilized by the meet and confer conference.

(i) Civil Actions. The following procedures are established for all civil actions filed to resolve Claims of \$375,000 or less:

- i. Within sixty (60) days, but no earlier than thirty (30) days, following the filing or responsive pleadings, the court shall submit the matter to non-binding mediation unless waived by mutual stipulation of both parties or unless mediation was held prior to commencement of the action in accordance with Public Contract Code section 9204 and the terms of this Contract. The mediation process shall provide for the selection within fifteen (15) days by both parties of a disinterested third person as mediator, shall be commenced within thirty (30) days of the submittal, and shall be concluded within fifteen (15) days from the commencement of the mediation unless a time requirement is extended upon a good cause showing to the court.
- ii. If the matter remains in dispute, the case shall be submitted to judicial arbitration pursuant to Chapter 2.5 (commencing with Section 1141.10) of Title 3 of Part 3 of the Code of Civil Procedure, notwithstanding Section 1114.11 of that code. The Civil Discovery Act of 1986 (Article 3 (commencing with Section 2016) of Chapter 3 of Title 3 of Part 4 of the Code of Civil Procedure) shall apply to any proceeding brought under this subdivision consistent with the rules pertaining to judicial arbitration. In addition to Chapter 2.5 (commencing with Section 1141.10) of Title 3 of Part 3 of the Code of Civil Procedure, (A) arbitrators shall, when possible, be experienced in construction law, and (B) any party appealing an arbitration award who does not obtain a more favorable judgment shall, in addition to payment of costs and fees under that chapter, also pay the attorney's fees on appeal of the other party.

(j) Government Code Claim Procedures.

- i. This Section does not apply to tort claims and nothing in this Section is intended nor shall be construed to change the time periods for filing tort claims or actions specified by Chapter 1 (commencing with Section 900) and Chapter 2 (commencing with Section 910) of Part 3 of Division 3.5 of Title 1 of the Government Code.
- ii. In addition to any and all requirements of the C pertaining to Contract Documents notices of and requests for adjustment to the Contract Time, Contract Price, or compensation or payment for extra work, disputed Work, construction claims and/or changed conditions, the Contractor must comply with the claim procedures set forth in Government Code Section 900, et seq. prior to filing any lawsuit against the County.
- iii. Such Government Code claims and any subsequent lawsuit based upon the Government Code claims shall be limited to those matters that remain unresolved



after all procedures pertaining to adjustment of the Contract Time or Contract Work for extra work, disputed work, construction claims, and/or changed conditions have been followed by Contractor. If Contractor does not comply with the Government Code claim procedure or the prerequisite contractual requirements, Contractor may not file any action against the County.

iv. **A Government Code claim must be filed no earlier than the date the Work is completed or the date the Contractor last performs Work on the Project, whichever occurs first. A Government Code claim shall be inclusive of all unresolved claims known to Contractor or that should reasonably be known to Contractor excepting only new unrelated Claims that arise after the Government Code claim is submitted.**

(k) **Non-Waiver.** The County’s failure to respond to a Claim from the Contractor within the time periods described in this Section or to otherwise meet the time requirements of this Section shall result in the Claim being deemed rejected in its entirety and shall not constitute a waiver of any rights under this Section.

15. MISCELLANEOUS.

(a) **Notice.** Except as provided in Section 6, all correspondence regarding this Agreement, including invoices, payments, and notices, shall be directed to the following persons at the following addresses and phone number:

County:

Ryan Pistochini
Director, Yolo County General Services Department
120 West Main Street, Ste G
Woodland, CA 95695
Telephone: (530) 406-8005

Contractor:

Telephone: _____

If written, correspondence shall be sent by personal delivery (including overnight delivery service); by U.S. Mail, postage prepaid; or by fax during business hours. Notices must be actually received to be effective.

(b) **Time of Essence.** Time is of the essence of this Agreement.



- (c) **Interpretation and Jurisdiction.** This Agreement shall be interpreted and applied in accordance with California law. In the event of a dispute between the parties as to the language of this Contract or the construction or meaning of any term hereof, this Contract shall be deemed to have been drafted by the parties in equal parts so that no presumptions or inferences concerning its terms or interpretation may be construed against any party to this Contract. Any action or proceeding arising out of this Contract shall be filed in a California Superior Court located in Woodland, California.
- (d) **Waiver.** A party's failure to insist on strict performance of this Agreement or to exercise any right or remedy upon breach of this Agreement shall not constitute a waiver of such performance, right, or remedy. No waiver is binding unless set forth in a writing signed by the waiving party.
- (e) **Assignments and Subcontracts.** Contractor shall not assign this Agreement. Contractor may subcontract any of the services described in Section 1 (Scope of Work) with County's prior written consent. Contractor shall require each subcontractor to agree in writing to be bound by Section 4 (Indemnification) and Section 6 (Insurance) of this Agreement. County shall consider all subcontractors to be Contractor's employees, and Contractor shall be responsible for their work.
- (f) **Integration.** This Agreement sets forth the parties' entire understanding regarding the matters set forth in herein. It supersedes all prior Agreements and representations, written and oral, and may be modified only by a written amendment approved by County's Chief Deputy County Administration Officer and signed by County and Contractor.
- (h) **Effective date.** This Agreement shall be effective on the last date shown below.
- (i) **Public Record.** Upon its execution, this Agreement (including all exhibits and attachments) shall be subject to disclosure pursuant to the California Public Records Act.

[Signatures on Following Page]



IN WITNESS WHEREOF, the parties have executed this Contract as of the date set forth above.

COUNTY OF YOLO:

CONTRACTOR:

By: _____

Ryan Pistochini
Director of General Services

By: _____

(Signature)

(Print Name & Title)

(Date)

APPROVED AS TO FORM
Philip J. Pogledich, Yolo County Counsel

By _____



SECTION 00 55 00

NOTICE TO PROCEED

Dated: xxxxxxxxxxxx, 2024

TO: xxxxxxxxxxxxxxxx (Contractor)

ADDRESS: xxxxxxxxxxxxxxxx
xxxxxxxxxxxxxxxxxx

RE: COUNTY OF YOLO

PROJECT:

Yolo County Ag Department Shops Building

BID NO. 01

CONTRACT FOR

You are notified that the Contract Time under the above contract will commence to run on xxxxxxxxxxxxxxxxxxxxxxxx, 2024. By that date, you are to start performing your obligations under the Contract Documents. In accordance with Article 3 of the Construction Agreement (Document 00 52 00), the date of final completion **60 calendar days** from the date of this notice.

THE COUNTY OF YOLO

By: _____

Ryan Pistochini
Director
Yolo County General Services Department



**SECTION 00 61 00
COUNTY OF YOLO**

PERFORMANCE BOND
(To Accompany Contract)

KNOW ALL PERSONS BY THESE PRESENTS:

THAT WHEREAS, the County of Yolo, organized and operating under the laws of the State of California, (hereinafter referred to as the "County") has awarded to _____, (hereinafter referred to as the "Contractor") an agreement for **Contract No.** _____, (hereinafter referred to as the "Project").

WHEREAS, the work to be performed by the Contractor is more particularly set forth in Contract No. for the Project dated _____, (hereinafter referred to as "Contract Documents"), the terms and conditions of which are expressly incorporated herein by reference; and

WHEREAS, the Contractor is required by the Contract Documents to perform the terms thereof and to furnish a bond for the faithful performance of said Contract Documents.

NOW, THEREFORE, we, _____, the undersigned Contractor and _____ as Surety, a corporation organized and duly authorized to transact business under the laws of the State of California, are held and firmly bound unto the County in the sum of _____ DOLLARS, (\$ _____), said sum being not less than one hundred percent (100%) of the total amount of the Contract, for which amount well and truly to be made, we bind ourselves, our heirs, executors and administrators, successors and assigns, jointly and severally, firmly by these presents.

THE CONDITION OF THIS OBLIGATION IS SUCH, that, if the Contractor, his or its heirs, executors, administrators, successors or assigns, shall in all things stand to and abide by, and well and truly keep and perform the covenants, conditions and agreements in the Contract Documents and any alteration thereof made as therein provided, on its part, to be kept and performed at the time and in the manner therein specified, and in all respects according to their intent and meaning; and shall faithfully fulfill all obligations including the one (1) year guarantee of all materials and workmanship; and shall indemnify and save harmless the County, its officials, officers, employees, and authorized volunteers, as stipulated in said Contract Documents, then this obligation shall become null and void; otherwise it shall be and remain in full force and effect.

As a part of the obligation secured hereby and in addition to the face amount specified therefore, there shall be included costs and reasonable expenses and fees including reasonable attorney's fees, incurred by the County in enforcing such obligation.

As a condition precedent to the satisfactory completion of the Contract Documents, unless otherwise provided for in the Contract Documents, the above obligation shall hold good for a period of one (1) year after the acceptance of the work by the County, during which time if Contractor shall fail to make full, complete, and satisfactory repair and replacements and totally protect the



County from loss or damage resulting from or caused by defective materials or faulty workmanship. The obligations of Surety hereunder shall continue so long as any obligation of Contractor remains. Nothing herein shall limit the County's rights or the Contractor or Surety's obligations under the Contract, law or equity, including, but not limited to, California Code of Civil Procedure Section 337.15.

Whenever Contractor shall be, and is declared by the County to be, in default under the Contract Documents, the Surety shall remedy the default pursuant to the Contract Documents, or shall promptly, at the County's option:

- i. Take over and complete the Project in accordance with all terms and conditions in the Contract Documents; or
- ii. Obtain a bid or bids for completing the Project in accordance with all terms and conditions in the Contract Documents and upon determination by Surety of the lowest responsive and responsible bidder, arrange for a contract between such bidder, the Surety and the County, and make available as work progresses sufficient funds to pay the cost of completion of the Project, less the balance of the contract price, including other costs and damages for which Surety may be liable. The term "balance of the contract price" as used in this paragraph shall mean the total amount payable to Contractor by the County under the Contract and any modification thereto, less any amount previously paid by the County to the Contractor and any other set offs pursuant to the Contract Documents.
- iii. Permit the County to complete the Project in any manner consistent with California law and make available as work progresses sufficient funds to pay the cost of completion of the Project, less the balance of the contract price, including other costs and damages for which Surety may be liable. The term "balance of the contract price" as used in this paragraph shall mean the total amount payable to Contractor by the County under the Contract and any modification thereto, less any amount previously paid by the County to the Contractor and any other set offs pursuant to the Contract Documents.

Surety expressly agrees that the County may reject any contractor or subcontractor which may be proposed by Surety in fulfillment of its obligations in the event of default by the Contractor.

Surety shall not utilize Contractor in completing the Project nor shall Surety accept a bid from Contractor for completion of the Project if the County, when declaring the Contractor in default, notifies Surety of the County's objection to Contractor's further participation in the completion of the Project.

The Surety, for value received, hereby stipulates and agrees that no change, extension of time, alteration or addition to the terms of the Contract Documents or to the Project to be performed thereunder shall in any way affect its obligations on this bond, and it does hereby waive notice of any such change, extension of time, alteration or addition to the terms of the Contract Documents or to the Project.



IN WITNESS WHEREOF, we have hereunto set our hands and seals this _____ day of _____, 20__.

(Corporate Seal)

Contractor/ Principal

By _____

Title _____

(Corporate Seal)

Surety

By _____

Attorney-in-Fact

(Attach Attorney-in-Fact Certificate)

Title _____

The rate of premium on this bond is _____ per thousand. The total amount of premium charges is \$ _____.

(The above must be filled in by corporate attorney.)

THIS IS A REQUIRED FORM

Any claims under this bond may be addressed to:

(Name and Address of Surety)

(Name and Address of Agent or Representative for service of process in California, if different from above)

(Telephone number of Surety and Agent or Representative for service of process in California)

NOTE: Signatures of those executing for Surety must be properly acknowledged. The bond must be accompanied by a properly acknowledged Power of Attorney from the Surety authorizing its agent to bind it to this bond. A copy of such Power of Attorney must be on file with the Yolo County Clerk.



SECTION 00 62 00

PAYMENT BOND

BOND NO. _____

KNOW ALL PERSONS BY THESE PRESENTS:

WHEREAS, the County of Yolo, State of California, ("Owner") has awarded to _____ ("Contractor/Principal") a contract (County Agreement No. _____, dated _____, referred to as the "Agreement") for the work described as _____. The Agreement is incorporated by this reference into this Payment Bond ("Bond"); and

WHEREAS, Contractor/Principal is required to furnish a bond in connection with the Agreement and pursuant to California Civil Code section 9550;

NOW, THEREFORE, we, _____ the undersigned Contractor/Principal, and _____, ("Surety"), a corporation organized and existing under the laws of the State of _____, and duly authorized to transact business under the laws of the State of California, as Surety, are held and firmly bound unto the County of Yolo, and to any and all persons, companies, or corporations entitled by law to file stop payment notices under California Civil Code Section 9100, or any person, company, or corporation entitled to make a claim on this bond, in the sum of _____ DOLLARS (\$ _____), which such sum being not less than one hundred percent (100%) of the total amount payable by the Owner under the terms of the Agreement, for which payment will and truly to be made, we bind ourselves, our heirs, executors and administrators, successors and assigns, jointly and severally, firmly by these presents.

THE CONDITION OF THIS OBLIGATION IS SUCH that if Contractor/Principal, its heirs, executors, administrators, successors, or assigns, or subcontractor, shall fail to pay any person or persons named in Civil Code section 9100; or fail to pay for any materials, provisions, or other supplies, used in, upon, for, or about the performance of the work contracted to be done, or for any work or labor thereon of any kind, or for amounts due under the Unemployment Insurance Code, with respect to work or labor thereon of any kind; or shall fail to deduct, withhold, and pay over to the Employment Development Department, any amounts required to be deducted, withheld, and paid over by Unemployment Insurance Code Section 13020 with respect to work and labor thereon of any kind, then Surety will pay for the same, in an amount not exceeding the amount herein above set forth, and in the event suit is brought upon this bond, also will pay such reasonable attorneys' fees as shall be fixed by the court, awarded and taxed as provided in California Civil Code Section 9550 et seq.

It is further stipulated and agreed that the Surety of this bond shall not be exonerated or released from the obligation of the bond by any change, extension of time for performance, addition, alteration or modification in, to, or of any contract, plans, or specifications, or agreement pertaining or relating to



any scheme or work of improvement herein above described; or pertaining or relating to the furnishing of labor, materials, or equipment therefor; nor by any change or modification of any terms of payment or extension of time for payment pertaining or relating to any scheme or work of improvement herein above described; nor by any rescission or attempted rescission of the contract, agreement or bond; nor by any conditions precedent or subsequent in the bond attempting to limit the right of recovery of claimants otherwise entitled to recover under any such contract or agreement or under the bond; nor by any fraud practiced by any person other than the claimant seeking to recover on the bond; and that this bond be construed most strongly against the Surety and in favor of all persons for whose benefit such bond is given; and under no circumstances shall the Surety be released from liability to those for whose benefit such bond has been given, by reason of any breach of contract between the Owner and Contractor/Principal or on the part of any obligee named in such bond; that the sole condition of recovery shall be that the claimant is a person described in California Civil Code section 9100, and who has not been paid the full amount of his or her claim; and that the Surety does hereby waive notice of any such change, extension of time, addition, alteration or modification herein mentioned, including but not limited to the provisions of sections 2819 and 2845 of the California Civil Code.

Any notice to Surety may be given in the manner specified in the Agreement and delivered or transmitted to Surety as follows:

Attn: _____
Address: _____
City/State/Zip: _____
Phone: _____
Fax: _____
Email: _____

[REMAINDER OF PAGE LEFT INTENTIONALLY BLANK]



IN WITNESS WHEREOF, two identical counterparts of this Bond, each of which shall for all purposes be deemed an original thereof, have been duly executed by Contractor/Principal and Surety above named, on the ____ day of _____, 20__.

(SEAL)
Contractor/Principal

By: _____
Contractor/s Representative

Contractor/Principal's Address

City, State, Zip

(SEAL)
Surety

By: _____
Surety's Representative

Surety's Address

City, State, Zip

Telephone Number

NOTE: Signatures of those executing for Surety must be properly acknowledged. The bond must be accompanied by a properly acknowledged Power of Attorney from the Surety authorizing its agent to bind it to this bond. A copy of such Power of Attorney must be on file with the Yolo County Clerk.



SECTION 00 62 10

INDEMNIFICATION

Section 2.05 of the General Conditions - **INDEMNIFICATION**

Contractor shall pay the cost of defense, indemnify, and save harmless the County of Yolo and all its officers, agents and employers from any and all claims, demands, damages, costs expenses, injury and liability of every kind, nature and description, arising or alleged to have arisen directly or indirectly from the performance or attempted performance of the Agreement for Construction of the Work, or from the nature of the Work, or by products, materials or equipment installed in or used on the Work, howsoever the same may be caused, without set off due to the Contractor's right, if any, to apportionment between joint tortfeasors.

This indemnity obligation extends to, but is not limited to, all acts, errors, omissions, and active and/or passive negligence by the Contractor, all subcontractors, all material suppliers, and their officers, employees, agents, or subcontractors, and includes all acts, errors, omissions, and active and/or passive negligence alleged to be joint or concurrent by them and the County or any of its officers, employees, agents, independent contractors or consultants, save only liability caused exclusively by the sole negligence, willful misconduct or defects in design provided by the County or its officers, employees, agents or independent contractors (other than the Prime Contractor) who are directly responsible to the County.

This indemnity obligation expressly extends to and includes, but is not limited to any and all claims, demands, damages, costs, expenses, or liability occasioned as a result of damages to the work, the Site or improvements thereon, or to adjacent property; and for injuries occurring after completion of the Work, as well as during the progress of the Work; and as a result of the violation of any provision of Federal or State law; and for inverse condemnation or equitable relief; and occasioned by personal and/or bodily injury to or death of any person, or any damage to property owned by any person while on or about the premises by right or not, whenever the work is alleged to have been a contributing cause in any degree whatsoever.

Nothing contained in this indemnity provision shall be construed to require the Contractor to indemnify the County in contravention of Section 2782 of the Civil Code. Contractor's responsibility for such defense and indemnity obligations shall survive the termination or completion of this Agreement for the full period of time allowed by law. The defense and indemnification obligations of this Agreement are undertaken in addition to, and shall not in any way be limited by, the insurance obligations contained in this Agreement. In providing any defense under this Section, the Contractor shall use counsel reasonably acceptable to the County.

AGREEMENT/ACKNOWLEDGMENT

Contractor agrees that he/she has read and agrees to the indemnification clause as written above.

Date

Authorized Representative

Title



SECTION 00 62 20

IRAN CONTRACTING ACT

As required by California Public Contract Code Section 2204, the Contractor certifies subject to penalty for perjury that the option checked below relating to the Contractor's status in regard to the Iran Contracting Act of 2010 (Public Contract Code Section 2200 *et seq.*) is true and correct:

The Contractor is not:

- (1) identified on the current list of person and entities engaged in investment activities in Iran prepared by the California Department of General Services in accordance with subdivision (b) of Public Contract Code Section 2203; or
- (2) a financial instruction that extends, for 45 days or more, credit in the amount of \$20,000,000 or more to any other person or entity identified on the current list of persons and entities engaging in investment activities in Iran prepared by the California Department of General Services in accordance with subdivision (b) of Public Contract Code Section 2203, if that person or entity uses or will use the credit to provide goods or services in the energy sector in Iran.

The County has exempted the Contractor from the requirements of the Iran Contracting Act of 2010 after making a public finding that, absent the exemption, the City will be unable to obtain the goods and/or services to be provided pursuant to the Contract.

The amount of the Contract payable to the Contractor for the Project does not exceed \$1,000,000.

Signature: _____

Printed Name: _____

Title: _____

Firm Name: _____

Date: _____

Note: In accordance with Public Contract Code Section 2205, false certification of this form shall be reported to the California Attorney General and may result in civil penalties equal to the greater of \$250,000 or twice the Contract amount, termination of the Contract and/or ineligibility to bid on contracts for three years.



SECTION 00 62 23

FLEET COMPLIANCE CERTIFICATION

Bidder hereby acknowledges that they have reviewed the California Air Resources Board's policies, rules and regulations and are familiar with the requirements of Title 13, California Code of Regulations, Division 3, Chapter 9, effective on January 1, 2024 (the "Regulation"). Bidder hereby certifies, subject to penalty for perjury, that the option checked below relating to the Bidder's fleet, and/or that of their subcontractor(s) ("Fleet") is true and correct:

- The Fleet is subject to the requirements of the Regulation, and the appropriate Certificate(s) of Reported Compliance have been attached hereto.
- The Fleet is exempt from the Regulation under section 2449.1(f)(2), and a signed description of the subject vehicles, and reasoning for exemption has been attached hereto.
- Bidder and/or their subcontractor is unable to procure R99 or R100 renewable diesel fuel as defined in the Regulation pursuant to section 2449.1(f)(3). Bidder shall keep detailed records describing the normal refueling methods, their attempts to procure renewable diesel fuel and proof that shows they were not able to procure renewable diesel (i.e. third-party correspondence or vendor bids).
- The Fleet is exempt from the requirements of the Regulation pursuant to section 2449(i)(4) because this Project has been deemed an Emergency, as defined under section 2449(c)(18). Bidder shall only operate the exempted vehicles in the emergency situation and records of the exempted vehicles must be maintained, pursuant to section 2449(i)(4).
- The Fleet does not fall under the Regulation or are otherwise exempted and a detailed reasoning is attached hereto.

Name of Bidder: _____

Signature: _____

Name: _____

Title: _____

Date: _____



FOR USE BY THE PRIME CONTRACTOR WITH THE COUNTY OF YOLO
SECTION 00 70 00

GENERAL CONDITIONS
ARTICLE 1.

- Index -

ARTICLE 1. DEFINITIONS AND PRINCIPLES OF INTERPRETATIONS..... 1

Section 1.01 - Defined Terms 1

Section 1.02 - Addendum/Addenda 1

Section 1.03 - Agreement for Construction..... 1

Section 1.04 - Allowance 1

Section 1.05 - Award of Contract; Date 1

Section 1.06 - Bid 2

Section 1.07 - Board of Supervisors/County Administrative Officer..... 2

Section 1.08 - Certification 2

Section 1.09 - Change Order..... 2

Section 1.10 - Clarifications..... 2

Section 1.11 - Contract Administrator/Project Manager..... 2

Section 1.12 - Contract Documents/Project Manual 2

Section 1.13 - Contract Drawings 2

Section 1.14 - Contract Price 3

Section 1.15 - Contract Time 3

Section 1.16 - Contractor: Prime Contractor..... 3

Section 1.17 - County 3

Section 1.18 - County Inspector..... 3

Section 1.19 - Day/Holiday; Working Day; Counting Days 3

Section 1.20 - Reserved 4

Section 1.21 - Materials 4

Section 1.22 - Notice of Cessation of Work..... 4

Section 1.23 - Notice of Completion..... 4

Section 1.24 - Program Manager 4

Section 1.25 - Project..... 4

Section 1.26 - Project Architect/Engineers/Consultants 4

Section 1.27 - Reference to Codes 5

Section 1.28 - Site 5

Section 1.29 - Specifications 5

Section 1.30 - Subcontractor 5

Section 1.31 - Submittals 5

 A. Shop Drawings 5

 B. Product Data..... 5

 C. Samples 6

Section 1.32 - Supplementary Conditions..... 6

Section 1.33 - Work/Notice to Proceed..... 6

Section 1.34 - Work Authorizations..... 6



ARTICLE 2. BONDS; INDEMNIFICATION; INSURANCE.....7

Section 2.01 - Bonds; Submittals7
Section 2.02 - Performance Bond7
Section 2.03 - Labor and Materials Payment Bond.....7
Section 2.04 - Contract Bond.....7
Section 2.05 - Indemnification7
Section 2.06 - Indemnification of Adjacent Property Owners8
Section 2.07 - Insurance; Submittals.....8
Section 2.08 - Contractor’s Insurance Requirements8
Section 2.09 - Subcontractors’ Insurance.....9
 A. Insurance Coverage Requirements9
 B. (Reserved).....9
 C. Contractor Responsibilities9
Section 2.10 - Workers’ Compensation & Employees’ Liability Insurance9
Section 2.11 - Posting at Site9
Section 2.12 - Effective Date of Policies9

ARTICLE 3. INITIAL SUBMITTALS AND TIME OF WORK.....10

Section 3.01 - Progress Schedule and Schedule of Values10
 A. Progress Schedule10
 B. Schedule of Values.....10
Section 3.02 - Initial Submittals.....10
 A. Schedule of Unavailable Materials.....10
 B. Schedule of Substitutions10
 C. Schedule of Item Requiring Long Order Lead Time.....10
 D. Subcontractor Insurance.....11
 1. First-Tier Subcontractors11
 2. Lower-Tier Subcontractors11
 E. Subcontractors: Allocation of Work11
 F. Schedule of Submittal Dates11
Section 3.03 - Approval of Initial Submittals’ Effect.....11
Section 3.04 - Commencement and Prosecution of Work.....11
Section 3.05 - Other Submittals12
Section 3.06 - Time of Essence.....12
Section 3.07 - Date of Completion.....12
Section 3.08 - Extension of Time; Unavoidable Delays12
 A. Unavailable Materials12
 B. Force Majeure12
 C. Unseasonable Weather12
 D. Time Extension Due to Change Orders or Work Authorizations.....13
 E. Delay Due to Rejected Submittals13
 F. County Caused Delays.....13
Section 3.09 - Notice of Delays; Submittals14
Section 3.10 - Investigation; Procedure14
Section 3.11 - Discretionary Time Extension for Best Interest of County14
Section 3.12 - Liquidated Damages15
Section 3.13 - Extension of Time Not a Waiver15
Section 3.14 - Suspensions Exceeding One Year.....15
Section 3.15 - Effect of Stop Work Notice15



ARTICLE 4. SCOPE & INTENT OF CONTRACT DOCUMENTS; CLARIFICATIONS..... 16

Section 4.01 - Basic Intent and Scope of Contract Documents..... 16
Section 4.02 - Harmonization of Contract Documents 16
Section 4.03 - Locations..... 18
Section 4.04 - Site Conditions..... 18
Section 4.05 - Project Record Documents 18
Section 4.06 - Contractor’s Supervision and Coordination of the Work..... 18
Section 4.07 - Clarifications Authorized..... 19
Section 4.08 - Clarifications; Procedure 19
 A. Contract-Initiated Requests..... 19
 B. County-Initiated Clarifications 19
 C. Incorporation in Contract 19
 D. Procedure for Extra Work Claims..... 19
Section 4.09 - Contract Administrator’s Investigation and Response Time..... 19
Section 4.10 - Dispute as to Scope of Contract Documents 20

ARTICLE 5. SUBMITTALS 21

Section 5.01 - Required Submittals; Time 21
Section 5.02 - Time for Submittals 21
 A. Time Generally 21
 B. Submittals within Twenty-One (21) Days Following Notice to Proceed 21
 C. Submittals after Twenty-One (21) Days Following Issuance of the Notice 22
 to Proceed
Section 5.03 - Contractor’s Responsibilities Regarding Submittals..... 22
Section 5.04 - Action on Submittals 22
Section 5.05 - Effect of Acceptance of Submittals..... 23

ARTICLE 6. MATERIALS; STORAGE; PAYMENT; CERTIFICATIONS..... 26

Section 6.01 - Quality of Material and Products 24
Section 6.02 - Better Material or Process..... 24
Section 6.03 - Industry Standards 24
Section 6.04 - Materials and Products Storage 25
Section 6.05 - Time for Delivery of Materials/Early Delivery..... 25
 A. Basic Requirement 25
 B. Early Delivery of Materials..... 25
Section 6.06 - Spare Parts and Maintenance Materials 26
Section 6.07 - Providing and Paying for Materials, Etc. 26
Section 6.08 - Warranty of Title..... 26
Section 6.09 - Patents and Royalties 27
Section 6.10 - Payment of Federal or State Taxes..... 27
Section 6.11 - Product Certification 27

ARTICLE 7. PRODUCT OPTIONS AND SUBSTITUTIONS 28

Section 7.01 - Applicability of Article 28
Section 7.02 - Effect of Brand Name Materials Specification 28
Section 7.03 - Necessity for Substitution Requests..... 28
Section 7.04 - Time for Requesting Substitutions 28



Section 7.05 - Application for Substitutions; Contents.....29
Section 7.06 - Action on Request.....29
Section 7.07 - Samples and Testing of Proposed Substitutions.....30
Section 7.08 - Design Costs for Substitution30
Section 7.09 - Effect of Acceptance.....30

ARTICLE 8. SAMPLES, TESTS AND TESTING LABORATORIES33

Section 8.01 - Contract Compliance Testing; Samples31
Section 8.02 - Delivery of Samples.....31
Section 8.03 - Testing Laboratory; Costs31
Section 8.04 - Re-Testing.....31
Section 8.05 - Access to Site, Cooperation32
Section 8.06 - Damage Due to Testing32
Section 8.07 - Results of Sampling/Testing32
Section 8.08 - Effect of Sampling and Testing32
Section 8.09 - Code Compliance Testing; Costs.....32

ARTICLE 9. REJECTION AND REPLACEMENT OF WORK AND MATERIALS..... 33

Section 9.01 - Rejection of Materials and Workmanship.....33
Section 9.02 - Removal of Rejected Materials.....33
Section 9.03 - Failure to Remove Rejected Materials.....33
Section 9.04 - Failure to Correct Rejected Work; Withhold and Deduction33
Section 9.05 - Reservation of Rights.....33

ARTICLE 10. SUPERVISION AND LABOR.....34

Section 10.01 - Skilled Labor34
Section 10.02 - No Tenancy.....34
Section 10.03 - Dismissal of Unsatisfactory Employees.....34
Section 10.04 - Personal Attention and Superintendence; Contractor’s Agent.....34
Section 10.05 - Authorized County Visitors to the Site34
Section 10.06 - Relationships of Employees and County Employees and the Public35

ARTICLE 11. SUBCONTRACTORS; LISTING AND BID; SUBSTITUTION36

Section 11.01 - Subcontractors; Contractor's Supervision36
Section 11.02 - Disputes Between Subcontractor and/or Contractor36
Section 11.03 - Listing of Subcontractors37
Section 11.04 - Termination of Unsatisfactory Subcontractors.....37
Section 11.05 - Subcontractors’ Insurance.....37

**ARTICLE 12. STATE REQUIREMENTS REGARDING WAGES, HOURS, AND
EQUAL OPPORTUNITY.....38**

Section 12.01 - Prevailing Wage Rate Notice.....38
Section 12.02 - Payment of Prevailing Wage Rates.....38
Section 12.03 - Wage Rates for Crafts Not Listed38
Section 12.04 - Records of Hours Worked and Wages39
Section 12.05 - Additional Requirements for Labor Compliance39



Section 12.06 - Underpayment of Wages	40
Section 12.07 - Apprentices	40
Section 12.08 - Penalties	40
Section 12.09 - Hours of Work and Approval of Schedules	41
Section 12.10 - Compliance with State Anti-Discrimination Laws	41
<u>ARTICLE 13. FEDERAL REQUIREMENTS REGARDING WAGES, HOURS, AND</u>	42
<u>EQUAL OPPORTUNITY</u>	
<u>ARTICLE 14. ON-SITE SECURITY; RISK OF LOSS; SITE SAFETY</u>	43
Section 14.01 - Project Site	43
Section 14.02 - Security of the Site	43
Section 14.03 - Risk of Loss	43
Section 14.04 - Protection of Workmen and Visitors to the Site	45
Section 14.05 - Excavation and Trenching; Safety	44
Section 14.06 - CAL OSHA	45
<u>ARTICLE 15. OFF-SITE SAFETY AND PROTECTION OF ADJACENT</u>	46
<u>PROPERTY; INDEMNITY</u>	
Section 15.01 - Protection of Adjacent Property During Excavation or other Operations, Notices	46
Section 15.02 - Underground Utilities; "USA"	46
Section 15.03 - Damage to or Blocking Streets, Street Improvements and Tracks	46
Section 15.04 - Fire Protection	47
Section 15.05 - Dust Control	47
Section 15.06 - Indemnity for Damage to Adjacent Property; Repairs	47
A. Indemnity	47
B. Repairs	47
Section 15.07 - Emergency Safety Actions	48
<u>ARTICLE 16. CONDUCT AND PROSECUTION OF THE WORK</u>	49
Section 16.01 - Basic Standard	49
Section 16.02 - Surveys and Field Engineering	49
Section 16.03 - Clearing Obstructions	49
Section 16.04 - Layout Work	49
Section 16.05 - Contractor's Equipment	49
Section 16.06 - Discovery of Unknown Conditions; Procedure	50
Section 16.07 - Equipment and Methods	50
Section 16.08 - Temporary Facilities and Services	50
Section 16.09 - Coordination of Work	50
Section 16.10 - Joining Work	51
Section 16.11 - Cutting and Patching of Work	51
Section 16.12 - Inspection of the Work of Other Contractors	51
Section 16.13 - Combination of Work with Other Contractors or County	51
Section 16.14 - Overtime and Holiday Work	52
Section 16.15 - Proof of Compliance with Contract Documents and Law	53



ARTICLE 17. CHANGE ORDERS; WORK AUTHORIZATIONS; ALLOWANCES 54

Section 17.01 - No Changes Without Consent; Performing Work Ordered..... 54
Section 17.02 - Change Orders Authorized; Procedure 54
 A. Change Order Authorized 54
 B. Methods of Calculation 54
 C. Overhead and Profit on Change Orders..... 54
 D. “Actual Costs” Defined..... 55
 E. Audit and Verification 55
 F. Deductive Change Orders..... 55
 G. Periodic Change Orders 55
Section 17.03 - Work Authorizations; Procedure 56
 A. Work Authorization Authorized..... 56
 B. Maximum Amounts 56
 C. Quotation by Contractor..... 56
 D. Claim for Price Adjustment..... 56
 E. Claim for Time Adjustment..... 56
 F. Accumulation of Work Authorizations..... 56
 G. Immediate Work Authorizations 56
Section 17.04 - Extra Work Claims; Procedure 57
 A. Notice to Contract Administrator 57
 B. Action by Contract Administrator 57
 C. Time 57
 D. Effect of Proceeding..... 57
 E. Scheduling 57
Section 17.05 - Allowances; Procedure 57
Section 17.06 - Minor Change Orders by County Administrative Officer..... 58
Section 17.07 - Change Orders Regarding Time for Completion 58
Section 17.08 - Change Orders Due to Unavailable Materials..... 58
Section 17.09 - Effect of Contractor's Acceptance of Change Order 59
Section 17.10 - Effect on Sureties 59

ARTICLE 18. INSPECTIONS 59

Section 18.01 - Access for Inspection..... 60
Section 18.02 - Notice of Readiness for Inspection 60
Section 18.03 - Contract Compliance Inspections 60
Section 18.04 - Inspection of Completed Work 60
Section 18.05 - Authority of County; Stop Work Notices 61
Section 18.06 - Effects of Inspections..... 61
Section 18.07 - Authority of Contract Administrator..... 61
Section 18.08 - Authority of County Inspector (s)..... 61
Section 18.09 - Building Inspections and Codes..... 62

ARTICLE 19. PUBLIC UTILITIES 63

Section 19.01 - Utilities Used During Construction..... 63
Section 19.02 - Lighting 63
Section 19.03 - Permanent Utilities; Installation..... 63
Section 19.04 - Toilet Facilities for Workers..... 63
Section 19.05 - Disruption of Utility Service..... 63



Section 19.06 - Utilities for County Personnel 64

ARTICLE 20. PERMITS, LICENSES, ORDINANCES AND REGULATIONS..... 65

Section 20.01 - Compliance with Construction Regulations..... 65
Section 20.02 - Permits; Fees..... 65
Section 20.03 - Compliance with Laws and Regulations..... 65
Section 20.04 - Violation of Laws and Regulations; Indemnity 65
Section 20.05 - Specific State Laws and Regulations 65
Section 20.06 - Compliance with Conditions of Permits 66
Section 20.07 - Compliance with Conditions of Grants..... 66
Section 20.08 - Harmonization with Contract Documents..... 67
Section 20.09 - Compliance with Hazardous Materials Reporting and Use Requirements; 67
Clean-up; Indemnity; Withhold

ARTICLE 21. PRESERVATION AND CLEANING..... 68

Section 21.01 - Protection of Work..... 68
Section 21.02 - Periodic Cleaning of Project 68
Section 21.03 - Final Cleaning of Project 68

ARTICLE 22. OCCUPANCY BY COUNTY..... 70

Section 22.01 - Use of Completed Work 70
Section 22.02 - Repairs or Renewals in the Work 70
Section 22.03 - Effect of Occupancy 70
Section 22.04 - Coordination with Other Activities 70
Section 22.05 - Price or Time Adjustments 70

ARTICLE 23. PROGRESS PAYMENTS..... 71

Section 23.01 - Submission of Claims 71
Section 23.02 - Payment; Withholds..... 72
Section 23.03 - Posting Securities in Lieu of Withholds..... 72
Section 23.04 - Retaining Additional Amounts; Grounds 73
Section 23.05 - Disbursement of Retained Amounts 74
Section 23.06 - Correction of Statement and Withholding of Payment 74
Section 23.07 - Effect of Progress Payments 74

ARTICLE 24. FINAL INSPECTION 75

Section 24.01 - Notice of Final Inspection..... 75
Section 24.02 - Punch List 75
Section 24.03 - Additional Submittals 75
Section 24.04 - Systems Demonstration 76



GENERAL CONDITIONS

ARTICLE 1.

DEFINITIONS AND PRINCIPLES OF INTERPRETATION

Section 1.01. DEFINED TERMS.

Whenever the following terms, titles, or phrases are used in the Contract Documents, the intent and meaning thereof shall be as defined in this Article.

Section 1.02. ADDENDUM/ADDENDA.

"Addendum" or "Addenda" are written documents furnished by the County before Award of the Contract which interpret Drawings and/or Specifications or answer questions of intended bidders and shall be incorporated in and are a part of the Contract Documents.

Section 1.03. AGREEMENT FOR CONSTRUCTION.

The "Agreement for Construction" is the written contract between the County and the Contractor by which the Contractor agrees to perform the Work necessary for full completion of the Project as intended, or the portions of the Project incorporated into the Contract. The Agreement for Construction includes the Contract Documents.

Section 1.04. ALLOWANCE.

An "Allowance" is the County's monetary and/or quantity estimate for equipment, materials, or work, the quantity and/or quality of which the County has not determined at the time of the Award of the Contract. The Contractor's bid includes all specified allowances, if any. "Allowance" also includes the contingency allowance specified to be included in the Contractor's bid, if any.

Section 1.05. AWARD OF CONTRACT; DATE.

The "Award of the Contract" is the action by the County Administrators Office of the County to execute the Agreement for Construction with the lowest responsible bidder and constitutes the County's acceptance of the Bid offer.

The Award of the Contract occurs after the County has determined which bid alternates, if any, are to be included in the Work, and has determined whether the apparent low bidder for the Work, including such alternates, is the lowest responsible bidder.

The date of the Award of the Contract is the date the County Administrators Office acts to authorize execution of the Agreement for Construction by the County, even though actual execution of the Agreement by the County does not occur until the Contractor submits the bonds and insurance certifications required by Article 2.



Section 1.06. BID.

The "Bid" shall mean the offer of the bidder to do the Work, when submitted on the prescribed bid form, duly executed and bonded. After Award of the Agreement for Construction by the County to the lowest responsible bidder, "Bid" shall mean the Contract Price.

Section 1.07. BOARD OF SUPERVISORS/COUNTY ADMINISTRATIVE OFFICER.

"Board of Supervisors" shall mean the duly elected officials constituting the Yolo County Board of Supervisors.

"County Administrative Officer" (CAO) is the County Administrative Officer of the County and reports to the Board of Supervisors, or the CAO's designee.

Section 1.08. CERTIFICATION.

When used in the context of required submittals regarding quality assurance, "Certification" shall be the verification required from recognized producers or associations attesting to a product's compliance with the Contract Documents. Examples include Underwriters Laboratory ("UL") listings.

Section 1.09. CHANGE ORDER.

A "Change Order" is a written order from the County to the Contractor authorizing an addition, deletion, or revision in the Scope of the Work, and/or an adjustment in the Contract price or Contract Time, issued after the execution of the Agreement for Construction.

Section 1.10. CLARIFICATIONS.

"Clarifications" are supplementary explanations, interpretations, instructions, and/or drawings issued by the Contract Administrator to further define the intent of the Contract Documents, pursuant to Article 4 of the General Conditions and procedures developed by the Contract Administrator pursuant thereto.

Clarifications involve no change in the Scope, Price or Time of the Agreement for Construction.

Section 1.11. CONTRACT ADMINISTRATOR/PROJECT MANAGER.

See Section 3(a) of the Agreement for Construction.

Section 1.12. CONTRACT DOCUMENTS/PROJECT MANUAL.

The "Contract Documents" shall include the Bid Proposal; the Designation of Subcontractors; the Agreement for Construction; the Bonds required thereby; these General Conditions; the Supplementary Conditions, if any; the Technical Specifications; all Documents comprising the bidding package; the Contract Drawings, (collectively referred to as "Project Manual"); all duly issued Addenda, Clarifications, Field Orders, and Work Authorizations; Change Orders; Supplemental Drawings; Contractor's Submittals approved pursuant to Articles 3 and/or 5 hereof, and the Contractor's Guarantee and Bonds. The Contract Documents comprise the "Agreement for Construction."

Section 1.13. CONTRACT DRAWINGS.

The "Contract Drawings" or "Drawings" shall mean the working drawings of the Work approved by the Board of Supervisors for the receipt of bids, plus all supplemental drawings approved by the County as



Addenda or Clarifications, or reproductions thereof, which show the location, character, dimensions, and details of the Work to be done, and which are part of the Agreement for Construction.

Section 1.14. CONTRACT PRICE.

The "Contract Price" is the total consideration for which the contractor agrees to perform the Work to produce a fully complete Project as intended by, and in accordance with, the Contract Documents. Unless modified by a duly issued Change Order, the Contract Price is the Contractor's Bid.

Section 1.15. CONTRACT TIME.

The "Contract Time" is the time specified in the agreement for Construction within which Contractor shall fully complete the Project in accordance with the Agreement for Construction. The Contract Time may be changed only by a Change Order duly issued by the Contract Administrator. Contract Time begins with the date of the Notice to Proceed and ends with acceptance of project work completion by the County. The number of days included in the agreement form includes the estimated number of construction days required and not the 35 days allowed for initial submittals and the 21 days allowed for County review of those submittals.

Section 1.16. CONTRACTOR; PRIME CONTRACTOR.

"Contractor" and "Prime Contractor" shall mean the person or persons, co-partnership or corporation, or his or their legal representatives, or successors, assigns, executors, or heirs, who have entered into the Agreement for Construction with the County of Yolo.

Section 1.17. COUNTY.

"County" shall mean the County of Yolo, a political subdivision of the State of California.

Section 1.18. COUNTY INSPECTOR.

The "County Inspector" is the person(s) and/or firm(s), if any, employed or engaged as (an) independent contractor(s) by the County to inspect the performance of the Work by the Contractor for compliance with the Contract Documents. The County Inspector is supervised by and reports to the Contract Administrator. The authority of the County Inspector is limited to that specified in the Contract Documents, and no additional authority has been granted nor shall be inferred.

The Project Manager performs the duties of the County Inspector unless a separate person or firm is engaged as County Inspector.

Section 1.19. DAY/HOLIDAY; WORKING DAY; COUNTING DAYS.

A "day" shall mean a calendar day of 24 hours, including each and every day of the year.

A "working day" is Monday through Friday, but shall exclude "holidays" established by the Sacramento Builders' Exchange.

Unless specified as being working days, all references herein to the number of days within which an action is to occur shall mean calendar days.

In computing working days or calendar days, the first day is excluded and the last day is included, unless it is a Saturday, Sunday, or holiday.



Section 1.20. RESERVED.

Section 1.21. MATERIALS.

"Materials" shall include all building materials, articles, supplies, and equipment delivered to the Site for incorporation in the Work. "Materials" includes everything incorporated into the work except personal services and labor, unless otherwise noted.

"Equipment" shall mean all pre-manufactured or partially pre-assembled products or components, assembled or partially assembled before delivery to the Site, and intended for incorporation into the Work.

Section 1.22. NOTICE OF CESSATION OF WORK.

A "Notice of Cessation of Work" is a notice containing the information required by Civil Code Section 3092, recorded in the Yolo County Recorder's Office, indicating that there has been a continuous cessation of labor on the Work of the Agreement for Construction for at least thirty (30) days prior to recordation of the Notice. The Notice shall specify the date on or about when the cessation of labor commenced.

Section 1.23. NOTICE OF COMPLETION.

A "Notice of Completion" is a notice containing the information required by Civil Code Section 3093, recorded in the Yolo County Recorder's Office, indicating that the Work of the Agreement for Construction has been accepted by the County.

Section 1.24. PROGRAM MANAGER.

If assigned by the Contract Administrator, "the Program Manager" is that County official responsible for team leadership in coordinating departmental program requirements; for preparation of the statement of project objectives; for presenting project objectives to the Contract Administrator and Board of Supervisors; for heading the design team (for designated projects); for arranging project financing; for maintaining program oversight during the bidding and construction phases; and for providing joint progress reports, with the Contract Administrator, to the Board of Supervisors. The program manager represents the County to State and/or Federal program offices sponsoring the project. In the absence of an assigned program manager, the Contract Administrator shall discharge these duties.

Section 1.25. PROJECT.

The "Project" is the total construction, of which the Work performed under the Agreement for Construction is the whole unless the Contract Documents specifically note to the contrary.

Unless so noted, the terms "Project" and "Work" are synonymous.

Section 1.26. PROJECT ARCHITECT/ENGINEER/CONSULTANT.

The "Project Engineer" is the firm employed or engaged as an independent contractor by the County to design the Project, and all sub-consultants or joint ventures of the Project Engineer. The authority of the Project Engineer to bind the County is limited to that authority specified in the Contract Documents, and no additional authority has been granted nor shall be inferred.

The Project Engineer advises the Contract Administrator in all aspects of the construction phase of the Project. The Project Engineer's functions include advice and assistance to the Contract Administrator in the correct interpretation and application of the Contract Documents. However, the



Contract Administrator or his/her designate is the County's representative on the Project, not the Project Engineer. The Project Engineer is not authorized independently to issue Addenda, Clarifications, Field Orders, Work Authorizations, or Change Orders, or in any other way to bind the County in discussions with the Contractor.

The Contractor shall deliver all correspondence relating to the proper execution of the Work to the Contract Administrator, with a copy delivered to the Project Engineer. The Contract Administrator reserves the right to consult with the Project Engineer prior to responding to the Contractor's correspondence.

When discussions between the Contractor and the Contract Administrator occur either on the Site or elsewhere, but the Project Engineer is not present, the Contract Administrator reserves the right to consult with the Project Engineer prior to issuing his final decision or instruction.

Section 1.27. REFERENCE TO CODES.

Unless otherwise noted, all references to statutes are to the law of the State of California as codified in the various specified codes.

Section 1.28. SITE.

"Site" is the area designated in the Contract Documents within which the Project is to be constructed.

Site for this purpose includes the area where Work on utility systems for the Project is to be performed by the Contractor under the Agreement for Construction, even though such areas may be designated as "off-site" on the Contract Drawings.

Section 1.29. SPECIFICATIONS.

"Specifications" shall mean the Technical Specifications portions of the Project Manual (Volume II) regarding qualities of materials and/or methods of workmanship to be furnished under the Contract. Specifications are organized into divisions, sections, and articles to enable grouping of the various portions of the Work into logical format, but this organization does not in any way restrict the Contractor in dividing the Work among subcontractors, or in establishing the extent of the Work to be performed by any trade.

Section 1.30. SUBCONTRACTOR.

Unless other specified, "subcontractor" refers to all contractors doing any work on the Project, including first, second, and subsequent tier contractors, excluding only the Prime Contractor.

Section 1.31. SUBMITTALS.

As used in Articles 3 and 5 hereof, "submittals" shall mean shop drawings, product data, and samples, as defined below:

- A. Shop Drawings are drawings, diagrams, schedules and other data specifically prepared for the Work by the Contractor or any subcontractor, manufacturer, supplier or distributor to illustrate some portion of the Work, and/or the method of installation of Materials.
- B. Product Data are illustrations, standard schedules, performance charts, certifications, instructions, brochures, diagrams and other information furnished by the Contractor to illustrate a material, product or system for some portion of the Work.



- C. Samples are physical examples that illustrate materials, equipment or workmanship and establish standards by which the Work will be judged.

As used elsewhere herein, "submittals" is a general term including all information, certifications, data or samples required to be delivered by the Contractor to the County.

Section 1.32. SUPPLEMENTARY CONDITIONS.

The "Supplementary Conditions" are specific clauses in the Project Manual setting forth conditions or requirements peculiar to the Work, and supplementary to the General Conditions.

Section 1.33. WORK/NOTICE TO PROCEED.

The "Work" is the completed construction required by the Contract Documents to perform the Agreement for Construction fully and completely, and includes all labor necessary to produce such construction, and all materials and equipment incorporated or to be incorporated in such construction.

Unless specifically noted in the contract Documents as not included in the Agreement for Construction, "work" includes all construction necessary to fully complete the Project as intended, including all bid alternates selected by the County for inclusion in the Work.

Unless so noted, the terms "Work" and "Project" are synonymous.

The Work shall commence upon issuance by the County of a Notice to Proceed so authorizing.

Section 1.34. WORK AUTHORIZATIONS.

"Work authorizations" are written orders to the Contractor, which amend the Contract Documents as described, and authorize the Contractor to proceed with the Work noted therein. Pursuant to Section 17.03 hereof, Work Authorizations may be cumulated into periodic Change Orders to adjust the Contract Price and/or Time, upon verification by the Contractor of the actual cost and delay, if any, caused by the Work Authorization.



ARTICLE 2.

BONDS; INDEMNIFICATION; INSURANCE

Section 2.01. BONDS; SUBMITTALS.

Within ten (10) calendar days following the Award of the Contract, and before the County will execute the Agreement for Construction, the Contractor to whom the Contract is awarded shall obtain and submit to the County bonds as set forth below in Sections 2.02 and 2.03. The Contractor is advised that a copy of the Power of Attorney authorizing execution of the bonds on behalf of the corporate surety must be filed with the Yolo County Clerk prior to approval of the bonds by the County.

Provision of the bonds required by Sections 2.02 and 2.03, and the insurance certificate required by Section 2.07 is a condition precedent to the Contractor's rights on the Agreement for Construction and a material covenant thereof.

Section 2.02. PERFORMANCE BOND.

The Contractor shall submit a faithful performance bond on the form provided with the Instructions to Bidders, duly executed by a responsible corporate surety authorized to do business in the State of California and acceptable to the county, conditioned upon the faithful performance by the contractor of all requirements of the Contract Documents. The amount of said bond shall be in a sum no less than One-Hundred Percent (100%) of the total Contract Price.

Section 2.03. LABOR AND MATERIALS PAYMENT BOND.

The Contractor shall submit a payment bond on the form provided with the Instructions to Bidders, duly executed by a responsible corporate surety authorized to do business in the State of California and acceptable to the County, which in all respects complies with Civil Code Section 9550 and following. This bond, hereinafter referred to as a "Payment Bond", shall be in a sum no less than One-Hundred Percent (100%) of the total Contract Price.

Section 2.04. CONTRACT BOND.

Prior to final payment as provided in Article 26, Contractor shall furnish a bond issued by a responsible corporate surety licensed to do business in the State of California in a form provided or approved by the County, and securing the performance by Contractor of his obligation undertaken by virtue of the guarantees required by Article 26. Such bond shall remain in full force and effect for a period of no less than one (1) year from and after recordation by the County of a Notice of Completion or a Notice of Cessation of Work, and shall be in a sum no less than ten (10%) percent of the total amount of the final Contract Price. In lieu of such bond, the Contractor may submit a certified or cashier's check, cash, or an irrevocable, unconditional letter of credit in a form acceptable to County, or may extend the final withhold account on terms and conditions acceptable to the county to secure performance of Contractor's obligations on the guarantee.

Section 2.05. INDEMNIFICATION.

Contractor shall pay the cost of defense, indemnify, and save harmless the County of Yolo and all its officers, agents and employers from any and all claims, demands, damages, costs expenses, injury and liability of every kind, nature and description, arising or alleged to have arisen directly or indirectly from the performance or attempted performance of the Agreement for Construction of the Work, or from the nature of the Work, or by products, materials or equipment installed in or used on the Work, howsoever the same may be caused, without set off due to the Contractor's right, if any, to apportionment between joint tortfeasors.



This indemnity obligation extends to, but is not limited to, all acts, errors, omissions, and active and/or passive negligence by the Contractor, all subcontractors, all material suppliers, and their officers, employees, agents, or subcontractors, and includes all acts, errors, omissions, and active and/or passive negligence alleged to be joint or concurrent by them and the County or any of its officers, employees, agents, independent contractors or consultants, save only liability caused exclusively by the sole negligence, willful misconduct or defects in design provided by the County or its officers, employees, agents or independent contractors (other than the Prime Contractor) who are directly responsible to the County.

This indemnity obligation expressly extends to and includes, but is not limited to any and all claims, demands, damages, costs, expenses, or liability occasioned as a result of damages to the work, the Site or improvements thereon, or to adjacent property; and for injuries occurring after completion of the Work, as well as during the progress of the Work; and as a result of the violation of any provision of Federal or State law; and for inverse condemnation or equitable relief; and occasioned by personal and/or bodily injury to or death of any person, or any damage to property owned by any person while on or about the premises by right or not, whenever the work is alleged to have been a contributing cause in any degree whatsoever.

Nothing contained in this indemnity provision shall be construed to require the Contractor to indemnify the County in contravention of Section 2782 of the Civil Code. Contractor's responsibility for such defense and indemnity obligations shall survive the termination or completion of this Agreement for the full period of time allowed by law. The defense and indemnification obligations of this Agreement are undertaken in addition to, and shall not in any way be limited by, the insurance obligations contained in this Agreement. In providing any defense under this Section, the Contractor shall use counsel reasonably acceptable to the County.

Section 2.06. INDEMNIFICATION OF ADJACENT PROPERTY OWNERS.

In the event the Contractor enters any agreement with the owners of any property adjacent to the Site and enters upon such property for the purpose of performing the Work, the Contractor shall fully indemnify, defend and save harmless such person, firm, or corporation, State or other governmental agency which owns or has any interest in such adjacent property. The form and content of such indemnification agreement shall be approved by County prior to commencement of the Work on or about such property. Contractor also shall indemnify the County as provided in Section 15.06.

Section 2.07. INSURANCE; SUBMITTALS.

The Contractor shall obtain, at its sole cost and expense, all insurance specified in the Agreement for Construction, and shall require all subcontractors to maintain insurance as specified therein. Continued maintenance of such insurance is a material covenant of the Agreement for Construction.

In addition to the submittals required by the Agreement for Construction, the County reserves the right to examine the insurance policies referenced in any such Certificate at any time, before or after issuance of the Notice to Proceed. Issuance of the Notice to Proceed shall not constitute a waiver of the County's right strictly to enforce the requirements of this Article.

The Contractor shall submit photocopies of its insurance and/or subcontractors' insurance policies when requested by the Contract Administrator.

Section 2.08. CONTRACTOR'S INSURANCE REQUIREMENTS.

Consistent with the Agreement for Construction, Contractor shall procure and maintain for the duration of the contract insurance against claims for injuries to persons or damages to property that may arise from or in connection with the performance of the work hereunder by the Contractor, his agents, representatives, employees or subcontractors. Any deviation from the required coverage specified in the Agreement for Construction must be approved by the County prior to the commencement of the work.



Section 2.09. SUBCONTRACTORS' INSURANCE.

Subcontractors

- A. **Insurance Coverage Requirements.** Contractor shall include all subcontractors as insureds under its policies or shall furnish separate certificates and endorsements for each subcontractor. All coverages for subcontractors shall be subject to all of the requirements stated in the Agreement for Construction and herein.
- B. **(Reserved)**
- C. **Contractor Responsibilities.** It shall be the responsibility of the Contractor to certify that all subcontractors (including lower-tier subcontractors) comply with these provisions, and to enforce their continued compliance throughout the progress of the Work. The submittals required to demonstrate initial compliance with this Section are specified in Section 3.02 hereof. Thereafter, the Contractor shall submit a certification to the required subcontractor's insurance when requested by the Contract Administrator. In lieu of the above the contractor can name all subcontractors on its policy as additional insured as approved by the County.

Section 2.10. WORKERS' COMPENSATION AND EMPLOYEES' LIABILITY INSURANCE

In accordance with Section 3700 of the Labor Code, the Contractor, and each subcontractor, shall secure the payment of workers' compensation to its employees as specified in the Agreement for Construction.

In the event that there is any employee working on the Project who is not protected under the Workers' Compensation statute for any reason, including because he is engaged in hazardous work, the Contractor shall provide, and shall cause each subcontractor to provide, adequate insurance for the protection of such employee. Such insurance shall comply with all requirements of the Labor Code.

Section 2.11. POSTING AT SITE.

The Contractor shall post, and cause all subcontractors to post, in a conspicuous place on the Project Site, a statement as required by Labor Code Section 3550, stating the name of the employer's compensation insurance carrier or that the employer is self-insured, and who is responsible for claims adjustment.

Section 2.12. EFFECTIVE DATE OF POLICIES.

The insurance required by this Article shall be in full force and effect at all times during prosecution of the Work and until the final completion and acceptance thereof by County, and every policy shall state that it shall not be assigned, canceled or reduced in coverage without thirty (30) days' prior written notice to County.



ARTICLE 3.

INITIAL SUBMITTALS AND TIME OF WORK

Section 3.01. PROGRESS SCHEDULE AND SCHEDULE OF VALUES.

- A. **Progress Schedule.** No later than thirty-five (35) calendar days following the Award of the Contract by the County and before issuance of a Notice to Proceed, the Contractor shall submit to the Contract Administrator a schedule showing the date on which work will commence on each part or class of the Work described with reference to the Divisions in the Technical Specifications and the responsible subcontractor(s); estimated dates of completion of such parts or classes; the working days proposed for work, and the approximate percentage of Work scheduled for completion at any time. Critical path sequencing items shall be identified. The Progress Schedule shall be practicable and consistent with the time requirements of the Agreement.

When requested by the Contract Administrator, or when the Contractor requests a Contract Time Extension Change Order, the Contractor shall submit a revised Progress Schedule showing changes to the originally approved Schedule necessary to complete the Work within the requested Contract Time.

- B. **Schedule of Values.** Simultaneously with the Progress schedule, the Contractor shall submit a Schedule of Values, showing a breakdown of the Contract Price with reference to the parts or classes or work shown on the Progress Schedule, and with reference to the Divisions in the Technical Specifications.

This schedule shall include products and materials allocated to each Allowance specified by the Contract Documents.

When requested by the Contract Administrator, or when the Contractor requests a Contract Price adjustment, the Contractor shall submit a revised Schedule of Values incorporating the requested Price adjustment(s).

Section 3.02. INITIAL SUBMITTALS.

No later than thirty-five (35) calendar days after the Award of the Contract by the County, and before issuance of a Notice to Proceed, the Contractor shall make the following initial submittals:

- A. **Schedule of Unavailable Materials:** A schedule showing any materials called for in the Contract Documents which are not obtainable for installation in the Project within the time limits set forth in the Progress Schedule, and the reasons known to Contractor for the unavailability.

The schedule shall detail Contractor's efforts to obtain the materials in question.

- B. **Schedule of Substitutions:** Contractor shall submit a schedule of all proposed Substitutions. The request for Substitutions shall in all respects comply with Article 7 of these General Conditions and shall include all requests for Substitutions of "an equal" item as defined by Public Contracts Code Section 3400 and Sections 7.02 and 7.03 hereof.

Failure to indicate such requested Substitutions on this schedule shall be deemed a waiver of the request for Substitution.

- C. **Schedule of Items Requiring Long Order Lead Time:** Contractor shall submit a schedule of all materials, the delivery of which will require more than 50% of the total Contract Time. The dates



shown on this schedule shall be consistent with the Progress Schedule, and the Schedule shall specify the dates of order and expected delivery dates for the specified materials.

D. **Subcontractor Insurance:**

1. **First-Tier Subcontractors:** The Contractor shall submit certificates of insurance for liability and workers' compensation insurance for all first-tier subcontractors, as required by Article 2 hereof. The County reserves the right to examine copies of the subcontractors' insurance policies.
2. **Lower-Tier Subcontractors:** If requested by the Contract Administrator, Contractor shall submit certificates of liability and workers' compensation insurance for any or all lower-tier subcontractors. The County reserves the right to examine copies of the lower-tier subcontractors' insurance policies.

E. **Subcontractors: Allocation of Work:** Contractor shall submit a chart showing all first and lower-tier subcontractors, and the contractual relationships between them, and identifying the Work to be done by each.

F. **Schedule of Submittal Dates:** Contractor shall submit a schedule indicating the dates upon which all required submittals will be submitted. Such schedules shall conform to Section 5.02 of the General Conditions and shall include all submittals required by the Contract Documents.

Section 3.03. APPROVAL OF INITIAL SUBMITTALS; EFFECT.

Prior to issuance of a Notice to Proceed, the Contract Administrator shall act upon the initial submittals required by Section 3.02.

The time for the Contract Administrator's action shall be twenty-one (21) days or less, from the date Contractor delivers submittals that conform to the Contract Documents.

In the event the Contract Administrator rejects an initial submittal, the Contractor shall not be entitled to any Contract Time extension on account of delay associated with re-submittal and re-approval. The County reserves the right to reject initial submittals in whole or in part, and the Contractor shall correct the submittal to comply with the Specifications and any requirements noted by the Contract Administrator in rejecting the submittal before issuance of a Notice to Proceed.

Once approved, all initial submittals shall be incorporated as part of the Agreement and Contractor shall comply therewith. The Contract Administrator is authorized to approve revisions to the Progress Schedule or Schedule of Values as required to incorporate approved changes in the Contract Time or Price.

Failure to meet the approved Progress Schedule is grounds for withholding Progress Payments pursuant to Article 23.

Section 3.04. COMMENCEMENT AND PROSECUTION OF WORK.

The Contractor shall not commence nor allow any subcontractor to commence work before receiving a Notice to Proceed from the County, specifying the day work is to commence. The Contractor shall commence work on such day, and shall prosecute the Work diligently to completion thereafter, at a rate that meets or exceeds the approved Progress Schedule.



Section 3.05. OTHER SUBMITTALS.

The Contractor shall make all submittals specified by the Technical Specifications for all Work to be done in the first sixty (60) days after issuance of the Notice to Proceed.

Section 3.06. TIME OF ESSENCE.

Time is of the essence of the Agreement for Construction.

Section 3.07. DATE OF COMPLETION.

The Contractor obligates himself to make the whole Work fully complete and satisfactory on or before the completion date specified in Section 2 of the Agreement for Construction, plus any Contract Time extensions approved by Change Order. The date of completion is the date of recordation of the Notice of Completion pursuant to Section 25.04; provided, however, that the date of completion for purposes of determining whether the Contractor has completed the Work within the time required by the Agreement for Construction shall be deemed to be the date the Contractor filed the "Contractor's Request for Final Payment" pursuant to Section 25.01 if, and only if, the Work was in fact fully complete and in full conformity with the Contract Documents when the Contractor's request was filed.

Section 3.08. EXTENSION OF TIME; UNAVOIDABLE DELAYS.

The Contractor shall not be granted a Contract Extension except on the issuance of a Change Order by the County Administrator, upon a finding that the delay in completion was unavoidable.

Delays in prosecution of parts or classes of the Work that are not demonstrated to prevent or delay completion of the entire Project within the Contract Time are not "unavoidable delays" for purposes of this section.

In all cases, the time authorized for extension of the Contract Time shall be no greater than the number of days directly attributable to the unavoidable delay which caused delay in the completion of the Project. "Unavoidable delay" for this purpose shall be defined as follows:

- A. **Unavailable Materials.** That materials or articles called for in the Contract Documents are not obtainable within the time required for timely completion; provided that such materials or articles were listed by the Contractor in the schedule required by Section 3.02 hereinabove; that the Contractor demonstrates that the unavailability of the materials is in fact the cause for the delay, and could not have been cured by adjusting the Progress Schedule; and that the unavailability of such materials is due to circumstances beyond the Contractor's control. If good cause for a delay is demonstrated pursuant to this subsection, the County, at its sole discretion, may grant a time extension or apply Section 17.09 hereof.
- B. **Force Majeure.** That delays in construction have resulted from circumstances beyond the control of the Contractor and which the Contractor could not have provided against by the exercise of reasonable care, prudence, foresight, and diligence. Unavoidable delays within the meaning of this subparagraph shall be those caused by acts of neglect of the County or its officers, agents, or employees; by acts of God, war, insurrection, civil disorder, fire, floods, epidemic, or strikes.
- C. **Unseasonable Weather.** An extension of time may be granted due to weather which is unsuitable for the Work currently in progress, upon the findings that the weather conditions in fact caused the delay in completion of the Project and that such weather conditions were not, and could not in the exercise of reasonable diligence, have been foreseen by the Contractor.



Unseasonable weather that, in the exercise of reasonable foresight and diligence, should be expected in the area at the time of year in question is not cause for an extension of time.

- D. **Time Extension Due to Change Orders or Work Authorizations.** A time extension may be granted due to a delay in the Project caused by the approval by the County of a Change Order or Work Authorization pursuant to Article 17. The Contractor shall be entitled to a time extension Change Order only when the extra work is demonstrated by the Contractor to have caused a delay in the Project. When a Work Authorization is issued, the Contract Administrator or County Administrative Officer is authorized to approve an allocation of time attributable to that Work Authorization. Approval of such allocation shall not constitute County's approval of a time extension to the overall Contract time but shall constitute County approval of the time allocated by the Contractor to perform the particular extra work in question.

The provisions of Sections 3.08 and 3.09 shall be applicable to requests for time extensions due to extra work.

The Contract Administrator may cumulate requests for time extensions due to Work Authorizations and process periodic Change Orders therefore, if warranted, or may process a Contract Time Extension Change Order simultaneously with the Contract Price Change Order, in their sole discretion.

- E. **Delay Due to Rejected Submittals.** In the event the Contract Administrator rejects a submittal, the Contractor shall not be entitled to any Contract Time extension on account of delay associated with re-submittal.

The procedure for submittals shall be as specified in Articles 5 and 7 (Substitutions) and the Technical Specifications. The Contract Administrator shall approve or reject submittals within twenty-one (21) days of the Contractor's delivery of the submittal, unless a different time is specified in the Technical Specifications for the particular submittal in question.

- F. **County Caused Delays.** In the event that the Project is delayed by acts of the County not authorized by the Contract Documents which the Contractor demonstrates will or have caused an unavoidable delay as defined by Subparagraph "B", the Contractor shall be entitled to a Contract Time and/or Contract Price Change Order to offset the extra time and/or costs incurred by the Contractor. Such extra costs shall be limited to those "actual costs" as defined in Section 17.02-D directly caused by the delay and incurred on this Project only. Overhead and profit shall be limited to that specified in Section 17.02-C hereof. Extra costs shall not include indirect costs nor loss of profits or increased costs on other work. Extra time shall be limited to that directly caused by the delay, as defined in Subparagraph "B" hereof.

The Contractor specifically agrees that a time extension and cost adjustment as provided herein is its sole remedy for County-caused delays and agrees to make no claim or demand for additional damages, nor claim an acceleration of the time for performance.

The Contractor shall not be entitled to any Contract Time Extension nor Contract Price adjustment for alleged County delays if the County has acted within the time limits specified by the Contract Documents.

The Contractor shall not be entitled to any cost adjustment for delays except for County caused delays as specified in this subsection.



Section 3.09. NOTICE OF DELAYS; SUBMITTALS.

Whenever the Contractor foresees any delay in the prosecution of the Work, and in any event immediately upon the occurrence of any delay which the Contractor regards as grounds for an extension and/or cost adjustment as specified in section 3.07., the Contractor shall notify the Contract Administrator in writing of the delay. Such notification shall specify with detail the cause asserted by the Contractor to constitute grounds for an extension, and/or cost adjustment. Failure of the Contractor to submit such a notice within five (5) days after the initial occurrence of the event giving rise to the delay shall constitute a waiver by the Contractor of any request for a time extension and/or cost adjustment, and no extension and/or cost adjustment shall be granted as a consequence of such delay.

With its request for time extension and/or cost adjustment, the Contractor shall submit evidence to demonstrate that the delay in prosecution in the work will result in an unavoidable delay in completion of the entire Project. Such evidence shall include a demonstration that the delayed portion of the Work will affect the critical path scheduling of the entire Project. The Contractor shall also submit a proposed revised Project Schedule, which accounts for the delay in completion of the entire Project caused by the delay in prosecution of part of the Project, and includes a revised critical path demonstrating how the Project will be completed within the proposed revised Contract Time.

Section 3.10. INVESTIGATION; PROCEDURE.

Upon receipt of a request for a Contract Time extension and/or cost adjustment, the Contract Administrator shall conduct an investigation of the facts asserted by the Contractor to constitute grounds for an extension and/or cost adjustment. The results of this investigation shall be reported by the Contract Administrator to the Contractor and the Contract Administrator shall indicate whether he will recommend for or against such extension.

The Contract Administrator may, in his sole discretion, defer this recommendation to allow the accumulation of time extensions and/or cost adjustment due to Work Authorizations into a periodic or final Change Order request.

If the Contract Administrator disallows the request, there shall be no allowance made for the time during which the request was pending, and the Contractor shall remain obligated to complete the Work in the time specified.

If the Contract Administrator approves the time extension change order, the new Progress Schedule submitted by the Contractor and approved by the County shall be deemed to amend the original Progress Schedule approved by the County pursuant to Section 3.03 hereof; thereafter, the amended Progress Schedule shall have the same force and effect as the originally approved Progress Schedule.

The Contractor agrees that the determination of the Contract Administrator as to whether grounds for an extension and/or cost adjustment exist, and if so, the duration of the extension and/or cost adjustment, shall be final and binding upon both County and Contractor.

Section 3.11 DISCRETIONARY TIME EXTENSION FOR BEST INTEREST OF COUNTY.

The County reserves the right to extend the Contract Time for completion of the Work if the County Administrator determines that such extension is in the best interest of the County.



Section 3.12. LIQUIDATED DAMAGES.

If the Work is not completed by Contractor in the time specified in Section 2 of the Agreement for Construction or within any period of extension authorized pursuant to this Article, the Contractor acknowledges and admits that the County will suffer damage, and that it is impracticable and infeasible to fix the amount of actual damages. Therefore, it is agreed by and between the Contractor and the County that the Contractor shall pay to the County as fixed and liquidated damages, and not as a penalty, the sum specified in the Agreement for Construction for each calendar day of delay until the Work is completed and accepted, and that both the Contractor and the Contractor's surety shall be liable for the total amount thereof, and that the County may deduct said sums from any monies due or that may become due to the Contractor.

This liquidated damage provision shall apply to all delays of any nature whatsoever, save and except only unavoidable delays approved by the Contract Administrator pursuant to Section 3.07 hereinabove.

The Contractor also acknowledges that the contract completion date for purposes of liquidated damages shall be the date of the Board of Supervisors' Resolution of Acceptance, unless Section 3.06 applies.

Section 3.13. EXTENSION OF TIME NOT A WAIVER.

Any extension of the Contract Time granted pursuant to this Article shall not constitute a waiver by the County, nor a release of the Contractor, from his obligations to perform this Contract in the Contract Time.

Granting of a time extension due to one circumstance on one request therefore shall not constitute a granting by the County of an extension of time for any other circumstance or the same circumstance occurring at some other time, and shall not be interpreted as a precedent for any other request for extension.

Section 3.14. SUSPENSIONS EXCEEDING ONE YEAR.

Should the Work be suspended for a period exceeding one (1) calendar year due to war conditions, labor conditions, legal actions, or for other conditions constituting the legal defense of impossibility of performance, the Contract and the County agree to enter an agreement terminating the Agreement for Construction upon the following terms and conditions:

The County shall be responsible only to pay the Contractor the actual value of the completed Work, to the County, less progress payments made to date, less any deductions authorized by the Contract Documents, and plus the ten (10%) percent withhold from previously issued progress payments.

As between the Contractor and the County, it shall be conclusively presumed that the actual value to the County for the Contractor's Work to the date of the last progress payment is not more than the actual amount of progress payments made to date plus the ten (10%) percent withhold from such progress payments; provided, however, that this section shall not preclude the County from deducting charges for work or materials which do not meet the requirements of the Contract Documents.

Such final payment shall be due only after any stop notices are resolved or the time to file stop notices has expired.

Section 3.15. EFFECT OF STOP WORK NOTICE.

If the County orders a suspension of the Work pursuant to Section 18.05, the days on which the suspension is in effect shall be included in determining the required completion date and shall not otherwise modify or extend the time within which the Contractor is to perform. In such event, the Contractor shall not be entitled to any damages or compensation on account of such suspension or delay, and the suspension and/are delay shall not constitute an acceleration of the performance time.



If the Contract Administrator determines that the Work conforms in all respects to the Contract Documents and releases the Stop Work Notice, the Contractor shall recommence work and may thereafter request a time extension pursuant to Section 3.07-F hereof. Sections 3.07, 3.08, and 3.09 shall apply to such requests.

ARTICLE 4.

SCOPE AND INTENT OF CONTRACT DOCUMENTS; CLARIFICATIONS

SECTION 4.01. BASIC INTENT AND SCOPE OF CONTRACT DOCUMENTS.

The basic intent of the Contract Documents is to describe the complete Project, including all materials, labor, equipment, and incidentals necessary for the proper execution and full completion of the work. The scope of the Agreement for Construction shall include everything directly called for by the contract Documents, and all work reasonably to be foreseen and/or inferred by competent contractors of the various required trades in order to completely perform the Work to produce the complete Project as intended.

The Agreement for construction does not recognize "substantial performance" as equivalent to "complete performance"; by entering the agreement, the contractor agrees, as a material covenant, to provide "complete performance" within the contract Time, for the amount included in the Contractor's bid as the Contract Price, unless modified by Change order. No extra compensation shall be allowed for any work or materials not directly appearing in the Contract Documents, but which a competent contractor should have foreseen and/or inferred would have been within the scope of the Agreement for Construction for work of the type and in the area of the Project. Even though items of work are not separately mentioned in the contract Documents, the Scope of the Agreement includes the furnishing and installation of all supplementary or miscellaneous items, appurtenances and devices incidental to or necessary for the sound, secure and fully complete performance of the work.

The Contract Price shall include all compensation for furnishing all labor, materials, tools, equipment and incidentals, and doing all work necessary fully to complete the Project as intended.

Section 4.02. HARMONIZATION OF CONTRACT DOCUMENTS.

The Contract Documents are complimentary, and what is required by anyone shall be as binding as if required by all. The Contract Documents are intended to be coordinated to describe and provide for the complete Project. However, where conflicts exist between the CONTRACT DOCUMENTS, such conflicts shall be clarified to the following order, the first taking precedence over the lower ranked:

CONTRACT CHANGE ORDERS
ADDENDA
SPECIAL PROVISIONS
TECHNICAL SPECIFICATIONS/PROVISION
CONTRACT DRAWINGS
CONSTRUCTION AGREEMENT (CONTRACT)
NOTICE TO BIDDERS
GENERAL CONDITIONS
STANDARD CONSTRUCTION SPECIFICATIONS
CONTRACTOR'S PROPOSAL BID

Scale drawings, full sized details, and technical specifications are intended to be coordinated and to agree fully. unless specifically noted otherwise in the Technical Specifications, all work and materials necessary for each unit of construction, even though only briefly mentioned or indicated, shall be furnished and installed fully and completely as specified in accepted submittals and the manufacturers' instructions and/or recommendations.



For convenience, the Specifications and Drawings in the Contract Documents are arranged in several sections, but such separation shall not be considered as the limits of the Work required by any separate trade. The terms and conditions of the Work to be performed by any subcontractor are strictly between the Contractor and such subcontractor.

REMAINDER OF PAGE INTENTIONALLY LEFT BLANK

////////////////////////////////////



Section 4.03. LOCATIONS.

The locations of equipment, wiring, piping, and similar materials and equipment are shown diagrammatically in the Contract Documents; actual Site conditions may not always permit their installation precisely in the location shown on the Contract Drawings. Contractor shall coordinate installation of equipment.

Section 4.04. SITE CONDITIONS.

Where investigations have been conducted by the County of existing conditions on the Site including subsurface conditions, such investigations are made for the purpose of design only and for the information of bidders. The results of such investigations represent only the statement by the County as to the circumstances and character of materials actually encountered by the county during the investigations. The County makes no guarantee or warranty, express or implied, that the conditions indicated are representative of conditions existing throughout the Site of the Project or any part of it, or that unanticipated conditions might not occur.

All excavation work shall be performed on an "unclassified basis; that is, shall include the removal of all material encountered including earth or rock formations, regardless of type or hardness thereof or groundwater conditions in the excavation, the cost of such excavations being included in the Contract Price at the time of bidding. Unclassified excavation work does not include drilling or blasting operations, unless otherwise specified in the Technical Specifications.

Section 4.05. PROJECT RECORD DOCUMENTS.

The Contractor shall maintain at the Site such Project record documents as are required by the Contract Documents.

At a minimum, the Contractor shall maintain one record copy of all drawings, specifications, addenda, work authorizations, change orders and other modifications, in good order and marked currently to record all changes made during construction, and accepted submittals.

With his request for final payment, the Contractor shall submit such record drawings to the Contract Administrator for approval. The contractor shall make all corrections necessary to produce accurate and complete record drawings showing the "as-built" Project.

The Project Record Documents shall be kept accurately and currently to show the precise locations and depths below finish grade of all components of the Project, as constructed.

Section 4.06. CONTRACTOR'S SUPERVISION AND COORDINATION OF THE WORK.

It is the Contractor's basic responsibility to execute and complete the Work necessary to construct the Project as intended by the Contract Documents, whether the Work is being performed directly by the Contractor, or by subcontractors of the Contractor. In all cases, the Contractor shall cooperate reasonably and in good faith with the Contract Administrator to the end that unnecessary Clarification requests are avoided, and the Work flows smoothly to a fully completed Project for the Contract Price, within the Contract Time.

The Contractor is responsible to thoroughly review and become familiar with the Contract Documents, and to identify conflicts, internal inconsistencies and/or ambiguities claimed by the Contractor to exist in the documents. By execution of the Agreement for Construction, the Contractor represents that it is fully competent, skilled and experienced to secure the performance of all Work needed to complete the Project intended and will utilize fully such competence, skill, and experience in interpreting the Contract Documents to produce the results intended. Prior to requesting a Clarification, the Contractor shall exert its best efforts to resolve problems in the field.



The Contractor is responsible to supervise and coordinate the work of all subcontractors. The Contractor shall exert its best efforts to resolve problems presented by Subcontractors.

The Contract Administrator shall consider no request by Contractor for a Clarification on its own behalf or on behalf of a subcontractor unless the request details the Contractor's efforts to resolve the issue, the results thereof, and demonstrate that the Contractor's efforts comply herewith. In all such cases, the Contract Administrator reserves the right to require the Contractor to make additional efforts to resolve the issue rather than issuing a Clarification.

Section 4.07. CLARIFICATIONS AUTHORIZED.

The Contract Administrator is authorized to furnish during the progress of the Work such Clarifications as the Contract Administrator deems are necessary to make clear and to define in greater detail the intent of the Contract Documents. Such Clarifications shall be incorporated by reference into the contract Documents, and the Contractor shall make his Work conform to all such Clarifications. In the event of conflict between the original Contract Documents and subsequently issued Clarifications, the Clarification most recently issued shall control.

Section 4.08. CLARIFICATIONS; PROCEDURE.

- A. **Contract-Initiated Requests.** Should the Contractor discover any conflicts or errors in the Contract Documents, or have any question concerning interpretation or clarification of the Contract Documents; or if it appears to the Contractor that the Work to be done or any matters relative thereto are not sufficiently detailed or explained in the Contract Documents; and provided that the Contractor has exerted its best efforts to interpret the Contract Documents and resolve the issue as required by Section 4.06; then before proceeding with the Work affected, the Contractor shall notify the Contract Administrator and request a Clarification.

The Contractor's request for Clarification shall be in writing, accompanied by sketch drawings and the materials necessary to explain and illustrate the problem in detail, and shall explain the Contractor's previous efforts to resolve the issue and the results thereof.

If the Contractor has proceeded with Work which was eligible for a clarification, but regarding which the Contractor failed to request a clarification, the Contractor shall not be entitled to, nor shall it request, any adjustment to the Contract Price or Time, caused by or resulting from such Work. The Contractor proceeds with such Work at its own risk, and shall make good any resulting damage, defect or extra work produced by such work.

- B. **County-Initiated Clarifications.** At any time, the Contract Administrator may issue Clarifications to explain the Work more fully. The Contractor shall perform the Work as required by the Clarification.
- C. **Incorporation in Contract.** All duly issued Clarifications shall become part of the Contract Documents upon delivery to the contractor.
- D. **Procedure for Extra Work Claims.** If the Contractor contends that any clarification requires Work beyond the Scope of the Agreement, the procedures in Section 17.05 shall be followed.

Section 4.09. CONTRACT ADMINISTRATOR'S INVESTIGATION AND RESPONSE TIME.

Upon receipt of Contractor's request for a Clarification, the Contract Administrator shall conduct such investigations as he deems appropriate, including consultation with the Project Architect as necessary to decide the Contractor's request for Clarification.



In all cases, if the request is incomplete or does not demonstrate the Contractor's compliance with this Article, the Contract Administrator may reject the request unprocessed, and return it to the Contractor. There shall be no time extension on account thereof.

Within fourteen (14) days following receipt of the Contractor's fully documented request for Clarification, the Contract Administrator shall issue his written response to the Contractor. If the Contract Administrator rejects the Contractor's request for Clarification, the Contractor shall perform the Work in accordance with the Contract Documents.

If the contract Administrator issues a Clarification, the Contractor shall perform the Work in accordance with the Clarification.

Section 4.10. DISPUTE AS TO SCOPE OF CONTRACT DOCUMENTS.

If the Contractor contends that any Work required by a clarification is outside the Scope of the Contract Documents as specified in section 4.01, the Contractor shall, within five (5) days of receipt of the Clarification, submit a written request for a Change Order to the Contract Administrator.

Such request shall specify all details of why the Contractor contends that the Work exceeds the Scope of the Contract Documents, and shall include an estimate by the Contractor of the cost to perform the Work, which complies with Section 16.05 hereof, and of the time to perform the Work, which complies with Section 3.08 hereof.

Upon timely delivery of a request by the Contractor, the Contract Administrator shall, within fourteen (14) days, consult with the Project Architect, as needed, and respond to the Contractor's request.

Such response shall either confirm the original Clarification, as within the scope of the work, and order the Work to be performed with no extension of time or increase in contract amount, or approve the Contractor's request, in which case a work Authorization will be issued, if authorized by Section 16.03 hereof, or Change Orders will be processed to adjust the Contract Price and/or Time equitably.

The Contractor acknowledges that the purpose of this Section is to allow the County advance Notice of Contractor's contention that a Clarification is beyond the Scope of the Agreement, so that the County may reconsider the Clarification before the Clarification Work is incorporated in the Project and such reconsideration is futile. Therefore, the Contractor agrees that if it proceeds with such Work without providing such Notice or before the Contract Administrator's response, the Contractor does so at its own risk and cost. Extra costs and/or time caused by or resulting from such Work shall be at the Contractor's expense, and the Contractor shall make good any resulting damage, defect, or extra Work produced by such Work.



ARTICLE 5.

SUBMITTALS.

Section 5.01. REQUIRED SUBMITTALS; TIME.

No portion of the Work requiring submittals shall be commenced until the submittal has been accepted by the Contract Administrator. Should the Contractor proceed with any work requiring a submittal before acceptance thereof, the Contractor shall remove and replace any Work which is not in accordance with the Contract Documents and shall bear the risk of loss due to resulting damage, defects, or added costs.

The Contractor shall provide all submittals required by the Technical Specifications in accordance with the procedures set forth in the Contract Documents 1.

All submittals shall be complete in every respect and shall include all information required both by the particular Technical Specification section and the Contract Documents.

The Contract Administrator shall not process submittals that are not complete in all respects, legible, reproducible, and sufficiently dimensioned and detailed to demonstrate compliance with the Contract Documents.

The Contract Administrator may reject all or any portions of a submittal which fails to comply with the Contract Documents, and the Contractor shall resubmit the entire submittal or the rejected portion, whichever is ordered by the Contract Administrator.

The Contractor shall be entitled to no Contract Time or Price adjustment for delays occasioned by the failure of the Contractor's submittals to comply with the Contract Documents.

Section 5.02. TIME FOR SUBMITTALS.

A. **Time Generally.** All submittals shall be submitted by the Contractor at the time specified by the Contract Documents, and the applicable portions of the Technical Specifications; provided, however, that in all events, Contractor shall submit all submittals so as not to cause a delay in the Work, including a reasonable time for review by the Contract Administrator. Unless otherwise specified in the Technical Specifications, the time for review by the Contract Administrator shall be no more than twenty-one (21) days.

B. **Submittals within Twenty-One (21) Days Following Notice to Proceed.** Within the first twenty-one (21) days following issuance by the County of a Notice to Proceed, the Contractor shall make the following submittals, including all information required by the General Conditions, Section 01340 of Division 1, and all other the applicable Technical Specifications:

- 1) All data required by the Contract Documents to substantiate a Request for Substitution.
- 2) Proposed substitutions, with all substantiating data, for all materials listed as "unavailable materials" on the Contractor's initial submittal, pursuant to Section 3.02-A hereof.
- 3) A critical path schedule, if required by the Contract Documents.



- 4) Any other submittals requested by the Contract Administrator to be received within the first 21 days following issuance of a Notice to Proceed.

C. **Submittals After 21 Days Following Issuance of the Notice to Proceed**: All other submittals required by the Contract Documents shall be submitted in conformity with the time requirements thereof, and in no event later than specified on the schedule of submittals approved pursuant to Section 3.02-G hereof.

Section 5.03. CONTRACTOR'S RESPONSIBILITIES REGARDING SUBMITTALS.

The Contractor shall review and approve all submittals, including those originating with subcontractors and suppliers, before submitting them to the Contract Administrator.

By making a submittal, the Contractor represents that it has determined and verified all materials, field measurements, and field construction criteria related thereto, and that it has checked and coordinated the information contained within such submittals with the requirements of the Work and of the Contract Documents.

It is the Contractor's responsibility to specifically point out any variation or discrepancy between submittals and the Contract Documents, or between a re-submittal and the notations on the original Submittal. The Contractor shall make specific mention of all such variations, along with an explanation of why they are requested, in his letter of transmittal.

Failure by the Contractor to identify in his letter of transmittal with the submittal any variation, discrepancy, or conflict with the Contract Drawings shall render acceptance of the submittal null and void, and the Contractor shall bear all risk of loss and reconstruction costs or delays.

The Contractor shall not be relieved of responsibility for any deviation from the requirements of the Contract Documents by the Contract Administrator's action on a submittal unless the contractor has complied with this section and the Contract Administrator expressly authorizes such deviation.

If any plumbing, mechanical, electrical, or structural modifications are required as a result of submittals that do not comply with the Contract Documents, such modification shall be made without extra cost to the County, and without extension of the Contract Time.

Section 5.04. ACTION ON SUBMITTALS.

The Contract Administrator shall take one of the following actions on a submittal:

"APPROVED": Fabrication, manufacture, or construction may proceed providing submittal complies with Contract Documents.

"APPROVED AS NOTED": Fabrication, manufacture, or construction may proceed providing submittal complies with Project Architect's notations thereon and Contract Documents. If for any reason the Contractor cannot comply with notations, the Contractor shall resubmit as described for submittals stamped **"REVISE AND RESUBMIT"**.

"REVISE AND RESUBMIT": Submittal does not comply with Contract Documents, and fabrication, manufacture, or construction shall not proceed. The Contractor shall make a new submittal conforming to the Contract Documents. Submittals stamped **"REVISE AND RESUBMIT"** shall be attached as an Exhibit to the re-submittal(s) for the specified items.

"NOT APPROVED": Fabrication, manufacture, product and/or construction does not conform to Contract Documents. Such fabrication, manufacture, product or construction shall not proceed and



are not permitted on the site. The Contractor shall make a new submittal, including a new proposed for fabrication, manufacture, product and or construction conforming to the Contract Documents.

"NO ACTION REQUIRED: Submittal is not required by this contract for this material or product. If Contractor wishes comment on this particular material or product, a submittal of a letter from Contractor explaining his purpose for submittal should accompany any future submittal.

Approval is only for conformity with the Design concept of the Project and compliance with the intent of the information given in the Contract Documents. Contractor is responsible for dimensions to be confirmed and correlated at the job site; for information that pertains solely to the fabrication processes or to techniques of construction; and for coordination of the work of all trades.

Section 5.05. EFFECT OF ACCEPTANCE OF SUBMITTALS.

The acceptance of submittals shall not relieve the Contractor of any obligation for quantities, accuracy of dimensions and details for property coordination, fitting and construction of the Work; for errors or omissions in the submittals; for conforming the Work to the requirements of the Contract Documents and all applicable laws and regulations; or from responsibility to fulfill the Contract at no extra cost to the County, within the Contract Time.

The County will review submittals for conformity with the Contract Documents, and acceptance thereof operates only with reference to such conformity. The County will attempt to discover errors, but the responsibility for accuracy and completeness of all submittals is the Contractor's.

After a submittal has been accepted, the Work shall proceed in accordance therewith.

The acceptance of samples provided with submittals shall be for the characteristics thereof, for the uses named in the action on the submittal, and for no other. Acceptance of samples shall not constitute a modification in any requirement of the Contract Documents unless expressly so noted, nor shall it relieve the Contractor of its obligation fully to perform the Agreement for Construction. All material or work installed after acceptance of a sample shall be equal or better than the sample in all respects.

REMAINDER OF PAGE INTENTIONALLY LEFT BLANK

////////////////////////////////////



ARTICLE 6.

MATERIALS; STORAGE; PAYMENT; CERTIFICATIONS.

Section 6.01. QUALITY OF MATERIAL AND PRODUCTS.

The Contractor shall, if required by the Contract Administrator, furnish satisfactory evidence as to the kind and quality of materials provided in addition to the submittals required by the Technical Specifications.

The Contract Administrator may require, and the Contractor shall submit, a list designating the source of supply of each item of material entering into the Construction of the Work, and in such event, such materials or products shall not be delivered to the Work nor installed therein until after the Contract Administrator has approved such list.

Section 6.02. BETTER MATERIAL OR PROCESS.

In the Event that Contractor furnishes a material, product, process or article better than that specified in the Contract Documents, the difference in cost of such material, product, process or article shall be borne by the Contractor, unless the County previously specifically authorized the use of such item and a Contract Price adjustment therefore.

Section 6.03. INDUSTRY STANDARDS.

Unless otherwise specified in the Technical Specifications:

- A. Any material specified by reference to a number, symbol or title or a specified standard such as a Commercial Standard, a Federal Specification, a Trade Association Standard, or other similar standard, shall comply with requirements in the latest revision thereof including any amendments or supplement thereto, in effect on the date of the Contractor's Bid, except as limited to type, class or grade, or modified in such reference.
- B. The standard referred to, except as modified in the Specifications, shall have full force and effect as though printed in these Specifications. These standards are not specified in detail for the reason that the manufacturers and trades involved are assumed to be familiar with their requirements.
 - 1) Where Federal Specifications are referred to as a measure of quality and standard, they refer to Federal Specifications established by the Procurement Division of the United States Government and are available from the Superintendent of Documents, U.S. Government Printing Office.
 - 2) Where Federal Specification numbers are used, they refer to the latest edition including amendments thereto.
 - 3) Where Commercial Standards or Product Standards are referred to as a measure of quality, standard and method of fabrication, they refer to Commercial Standards and Product Standards issued by the U.S. Department of Commerce.
 - 4) Where industry standards numbers are used, they refer to the latest tentative specifications, standards specifications, standards method or standard methods of testing, issued for example by the American Society for Testing Materials, unless specifically noted.

See Section 01 42 13 - Standard Abbreviations and Symbols for details on Abbreviations and Symbols.



Section 6.04. MATERIALS AND PRODUCTS STORAGE.

The Contractor shall confine the storage of all materials, products and equipment required in the performance of the Work to the area specified on the contract Drawings.

The County reserves the right, at the sole discretion of the Contract Administrator, to require materials to be stored off the Site in a bonded warehouse or other approved location. The County shall provide such location free of charge to the Contractor, or the Contractor shall be entitled to a Contract Price change order to off-set the actual cost thereof as defined in Section 17.02-D. Contractor shall not be entitled to overhead and profit on the rent of such facility.

The Contractor is admonished that the County has no obligation to provide a secure warehouse or other storage facilities; the Contractor takes the sole risk of loss or vandalism to any products or materials stored anywhere other than in a warehouse provided by the County.

All materials and products shall be stored in accordance with their manufacturers' instructions, with seals and labels intact and legible.

All materials, supplies and equipment to be incorporated in the Work shall be new, unless otherwise specified; of the type, capacity and quality specified; and free from defects. All materials shall remain in their original packages or containers until ready for use. The labels of all packages or containers shall remain affixed and shall be kept legible.

The Contractor shall protect the Work, materials and equipment from damage due to action of the elements, trespassers, and other causes. It shall properly store materials and equipment and, when necessary or when specified by the Technical Specifications, erect such temporary structures as is required to protect them from damage.

Section 6.05. TIME FOR DELIVERY OF MATERIALS: EARLY DELIVERY.

- A. **Basic Requirement:** Unless early delivery is authorized by the Contract Administrator pursuant to Subsection B. hereof, the Contractor shall limit delivery of materials and equipment to the Site to those materials and/or equipment needed for installation within thirty (30) days of the date of delivery. The Contract Administrator shall refuse payment for materials delivered to the Site that are not intended to be used within thirty (30) days of the date of delivery.
- B. **Early Delivery of Materials:** The County reserves the right to allow an earlier delivery date of any materials and/or equipment. Upon inspection and approval as specified below, the Contractor shall be entitled to progress payments therefore as specified in Section 23.01.

Upon application by the Contractor, the Contract Administrator, in his sole discretion, may authorize early delivery of materials and/or equipment, and payment therefore, subject to the following requirements:

1. For purposes of this Section, "materials and equipment" eligible for payment are defined as finished goods made specifically for the Project and requiring extensive time to be manufactured or obtained. Raw materials or work in progress and not yet delivered to an approved storage location are not eligible for payment. Finished items that are readily available for purchase are not eligible for payment.
2. The Contractor's request shall demonstrate that the proposed early payment is in the best interest of the Project by accomplishing time and/or money savings.



3. In his application for payment for such materials, the Contractor shall separately list the items for which payment is sought pursuant to this subsection. No payment shall be authorized unless the Contractor demonstrates that he is the unconditional owner of the equipment or material and executes a transfer of title to such equipment or material to the County with each request for early payment.
4. The materials for which a progress payment has been received shall be fully insured, with the County named as co-insured, segregated from the manufacturer's other work in progress and raw materials at the manufacturer's place of storage, and separately identified as being the property of the County of Yolo. Such insurance shall be primary, and the County's Builders' Risk insurance secondary.
5. The County retains the right to conduct inspections of such materials either during fabrication or during storage, at the manufacturer's plant or place of storage. The Contractor shall retain all risk of loss for such materials, however.
6. Payments for such materials shall be due only after such materials have either been delivered to the job site or to a storage location acceptable to the County, except that such payments shall not be included in the value for work in place for the purpose of calculating payments for labor and mark up.
7. The County reserves the right to specify requirements in addition to those stated above regarding early payment for materials. Such requirements shall be listed on the Contract Administrator's consent for early payments; the Contract Administrator hereby is authorized to provide such consents, with additional requirements, as are deemed necessary to protect the County.

Section 6.06. SPARE PARTS AND MAINTENANCE MATERIALS.

The Contractor shall provide spare parts and maintenance materials as required by the Technical Specifications.

Section 6.07. PROVIDING AND PAYING FOR MATERIALS, ETC.

Except as otherwise specifically stated in the Contract Documents, Contractor shall provide and pay for all materials, products, articles, processes, tools, equipment, and installation, and all associated superintendence of every nature whatsoever necessary to execute and complete the Work within the specified time.

Section 6.08. WARRANTY OF TITLE.

No material, article, product, supplies, or equipment for the Work under this Agreement shall be subject to any chattel mortgage, or a conditional sale or other agreement by which an interest therein or in any part thereof is retained by the seller or supplier.

The Contractor warrants that, upon demand by County at any time after a progress payment has been made therefore, the Contractor will deliver to the County clear title to any materials, supplies, and/or equipment for which such progress payment was made, but which has not as yet been incorporated into the Work, such title to be free from any claims, liens, or changes, save only the Contractor's claim for the 10% withhold attributable to such materials, supplies, or equipment.

The Contractor further warrants clear title to all material, supplies, and equipment installed or incorporated in the Work, and agrees upon completion of the Work to deliver the premises, together with all



improvements and appurtenances, constructed or placed thereon pursuant to the Agreement for Construction, to the County, free from any claims, liens, or charges.

The Contractor agrees that neither he nor any person, firm or corporation furnishings any materials or labor for any Work pursuant to the Agreement for construction shall have any right to a lien upon the premises or any improvement or appurtenances thereon; provided, however, that nothing contained in this section shall defeat or impair the rights of persons furnishing materials or labor under the Payment Bond posted by the Contractor, nor any rights covered under any law permitting such persons to look to funds due to the Contractor but withheld by the County.

This section shall not disallow the Contractor's installing any devices or equipment of utility companies or of governmental agencies, the title to which is commonly retained by the utility company or the agency.

Section 6.09. PATENTS AND ROYALTIES.

All fees, claims, or royalties for any patented or copyrighted invention, article, arrangement, or plan that may be used upon or in any manner connected with the doing of the Work or any part thereof shall be included in the price bid for doing the Work. The Contractor and his sureties shall protect and hold harmless the County and all of its officer, agents, and employees against any and all demands made for such fees or claims and against any and all suits, demands, claims, or causes of action brought or made by the holder of any invention, patent, copyright or trademark, or arising from any alleged infringement of any invention, patent, copyright, or trademark.

Before final payment, the Contractor shall furnish acceptable proof to the Contract Administrator of proper release from all such fees or claims.

Section 6.10. PAYMENT OF FEDERAL OR STATE TAXES.

Any Federal, State, or local tax, specifically including sales and use taxes, payable on materials incorporated in the Work shall be included in the Contract price and paid by the Contractor.

The County will furnish the contractor with a certificate, on forms provided by the Contractor, to the effect that such materials are for the exclusive use of the County.

Section 6.11. PRODUCT CERTIFICATION.

Where required by the Technical Specifications, the Contractor shall submit proper product Certifications, which demonstrate the product's conformity to the Technical Specifications. Article 5 shall apply thereto.



ARTICLE 7.

PRODUCT OPTIONS AND SUBSTITUTIONS.

Section 7.01. APPLICABILITY OF ARTICLE.

This Article authorizes the Contractor to request substitutions of equal materials pursuant to Public Contracts Code Section 3400. Applications for such Substitutions shall be considered by the County only if the contractor's submittal is received within the time and includes all information specified herein and in the Contract Documents.

The Contractor is responsible to file all such requests on behalf of all subcontractors and product supplies; the County shall consider no request filed by a subcontractor or product supplies.

Only one request for Substitution shall be considered for each product specified. If the Contractor's request for Substitution is denied, the Contractor shall provide the specified first preference product.

Section 7.02. EFFECT OF BRAND NAME MATERIALS SPECIFICATION.

Unless otherwise expressly specified, whenever in the Contract Documents any materials, products, processes or articles are indicated or specified by the name brands of the manufacturers or products, or by patent or proprietary names, such Specifications shall be deemed to be followed by the words, "or equal", unless the specification expressly states that there is no known equal, or that the particular product specified is a unique or novel product application required to be used in the public interest. When materials are specified by reference to brand names, such specification is intended to incorporate all specifications of the listed brand as the measure of the type, quality and utility of the material so specified, and is not intended to limit the bidding, directly or indirectly, to any one specific concern.

Section 7.03. NECESSITY FOR SUBSTITUTION REQUESTS.

If materials are specified only by reference to standards, with no brand or proprietary trade name listed, any product meeting the specified standards may be provided, and no request for Substitution is required. No product not meeting the specified standards shall be provided unless a change order is approved so authorizing.

If materials are specified by listing more than one manufacturer or product, and the specification does not list one as the first preference manufacturer or product and the others as optional, any manufacturer or product listed may be provided, and no request for Substitution is required. If material is proposed other than the listed manufacturers or products, a Substitution shall be proposed by the Contractor pursuant to this Article.

Section 7.04. TIME FOR REQUESTING SUBSTITUTIONS.

All requests for Substitutions shall be submitted to the Contract Administrator no later than thirty-five (35) calendar days from the date of the Award of Contract. Thereafter, this Article shall be of no further effect, and the Contractor shall provide only the material specified.

Any further requests to provide materials other than those specified shall be treated as Change Orders, subject to Article 16. The County reserves the right to refuse to accept applications for such Change Orders and has no obligation to review such applications. Such applications shall not be accepted for review unless the Contract Administrator has previously determined that it is in the County's best interest to do so.



Section 7.05. APPLICATION FOR SUBSTITUTIONS; CONTENTS.

Applications for Substitutions shall be accepted for review only if the application is timely filed, and includes the following information:

- A. All Technical Specification Section Number(s) where the material is specified;
- B. If the material is proposed as an "or equal" Substitution, submittals to demonstrate that the material in fact is equal in all respects to that specified or, if applicable, to the first preference specified, including detailed drawings, construction specifications, performance specifications and warranty information for the material proposed for Substitution.
- C. Complete Working Drawings and specifications demonstrating how the Substitution is to be incorporated into the Work so that the system of which the substituted material is a component will be a coordinated system fully compatible with all related systems, in conformity with the intent of the Contract Drawings.
- D. Complete identification of all changes in related Work necessary to accommodate the Substitution, including but not limited to structural, mechanical and electrical changes.
- E. Cost information necessary to evaluate the net difference in cost of the specified material against that proposed for Substitution, including the supplies' cost quotations and the Contractor's labor estimates.
- F. Contractor's written assurance that the material is in fact equal in all respects to the material specified, or if applicable, the first preference specified; and that if the Substitution is accepted, the Contractor will bear all costs of incorporating the substituted material into the Work to provide a complete system which conforms to the design intent; and that no Contract Price or Time increase will be sought by Contractor on account thereof.

Failure by the Contractor to identify all deviations from the Contract Documents in his request for Substitution shall render any County action taken thereon null and void. Contractor shall bear all costs resulting from any error in the request for Substitution.

Section 7.06. ACTION ON REQUEST.

Within twenty-one (21) days of receipt of complete submittals requesting a Substitution, with all supporting data necessary to evaluate the request, the Contract Administrator shall evaluate and act on the request. The decision of the Contract Administrator shall be final. No Contract Time Extensions shall be allowed on account of an incomplete request for Substitution or the timely decision on such request.

The Contract Administrator shall authorize a Substitution only if he finds that the material requested is equal in all respects to that specified and is consistent with the design intent of the Contract Drawings.

The Contractor shall bear the burden of proving to the County's satisfaction that the material proposed in the substitution request is of equal quality and performance to the originally specified material in all respects and is compatible with the design intent.

The Contract Administrator's evaluation shall consider, but is not limited to, the following factors:

- A. All product data for the originally specified material as against that for the requested Substitution;



- B. The compatibility of the substitution with the remaining components of the system(s) of which it is a part.
- C. The conformity of the Substitution with the design intent.
- D. The length and terms of the warranties for the material proposed in the Substitution.
- E. The net cost advantage to the County for granting the Substitution request.

Section 7.07. SAMPLES AND TESTING OF PROPOSED SUBSTITUTIONS.

If the Contract Administrator determines that samples and/or testing are required to decide a request for a Substitution, he shall so advise the Contractor, and specify the materials or work to be sampled and/or tested. The Contractor shall at no cost to the County, provide such samples and testing as required to evaluate the requested Substitution. The results of the testing shall be evaluated by the Contract Administrator before action on the Substitution request. The time during which the sampling and testing is being conducted shall not be included within the time specified in Section 7.06.

Section 7.08. DESIGN COSTS FOR SUBSTITUTION.

If a Substitution is accepted, Contractor shall bear all costs associated therewith, including the cost of architect's and/or engineer's services required to adapt the substitution to the design to the complete satisfaction of the County, and all costs of mechanical, electrical, structural or other changes needed to adapt the Substitution to the Work. Contractor shall also bear all cost increases to the County for construction management services being provided to the County by independent contractors, resulting from the substitution.

Section 7.09. EFFECT OF ACCEPTANCE.

If a Substitution is accepted, the Contractor shall be solely and directly responsible for setting accepted substituted materials and/or equipment and systems into the available space, and for the proper operation of the substituted equipment with all other equipment with which it may be associated, all in a manner acceptable to the County and which conforms to the design intent.

No time extension shall be granted on account of a Substitution. The Contract Price shall be adjusted by the price difference between the accepted Substitution and the originally specified (first preference) material. Neither acceptance nor rejection of a Substitution request shall relieve the Contractor of any obligation to perform the Agreement for Construction according to its terms, other than as expressly modified by the accepted Substitution.



ARTICLE 8.

SAMPLES, TESTS AND TESTING LABORATORIES.

Section 8.01. CONTRACT COMPLIANCE TESTING; SAMPLES.

Materials and/or work that require sampling and/or testing to determine compliance with the Contract Documents are specified in the Technical Specifications. The Contractor shall bear the full cost of providing samples when required to perform the specified tests, and shall take, store and provide such samples in the manner specified in the Technical Specifications, including Division 1.

All such samples shall be selected by the Contract Administrator or the Testing Laboratory employed by the County.

Section 8.02. DELIVERY OF SAMPLES.

The Contractor shall, at his sole cost and expense, furnish, package, mark, and store all samples to be tested. Chain-of custody and sample security precautions shall be utilized, as specified or as instructed by the Contract Administrator.

Collection, preparation, curing and delivery of all samples shall be made in ample time to allow the test to be made without delaying construction. No extra time will be allowed for the completion of the Work by reason of delay in testing.

Section 8.03. TESTING LABORATORY; COSTS.

The County shall employ and pay for the services of one or more independent testing laboratory(ies) ("Test Laboratory") to perform all required contract compliance testing expressly specified in the Technical Specifications as being provided by the County.

The County reserves the right to utilize the Yolo County Public Works concrete testing laboratory for any and/or all specified concrete or paving tests.

All testing not specified as being provided by the County shall be provided by the Contractor, using testing agencies with the specified qualifications.

The County reserves the right to require the Contractor to provide samples and to perform tests in addition to those samples and/or tests specified in the Technical Specifications. In the event the County orders such additional samples and/or tests, the County shall be obligated to pay therefore only if the sample and/or test is acceptable. If the sample and/or test does not comply with the Contract Documents, the County shall deduct the cost of the extra testing, and any subsequent re-testing, from the next progress payment.

If the Contractor determines that testing in addition to that specified is necessary and/or convenient, the Contractor shall employ a separate testing laboratory. The results of such tests shall not be binding on the County.

Section 8.04. RE-TESTING.

If as a result of any test, whether originally specified or not, any material or work is found to be unacceptable, it shall be rejected, and the original test and all further sampling and testing required by the



County shall be at Contractor's expense. Re-testing shall not be charged against the specified contingency or testing allowances, if any.

Section 8.05. ACCESS TO SITE; COOPERATION.

The Contractor shall allow free access at all times to the representatives of the County's testing laboratory or consultant to the Work, or to any off-site area where Work is being performed and shall point out the sources from which samples are taken.

The Contractor shall cooperate with the testing laboratory to facilitate execution of its services and shall provide quantities of samples as specified.

Section 8.06. DAMAGE DUE TO TESTING.

Contractor shall, at his sole cost and expense, repair all damage resulting from testing or retesting specified in the Contract Documents. The County shall issue a Contract Price adjustment for repair of damage due to sampling or testing in addition to that specified in the Contract Documents, if and only if the additional testing shows full compliance with the Contract Documents; otherwise, the Contractor shall be obligated to repair such damage.

Section 8.07. RESULTS OF SAMPLING/TESTING.

No materials or work of which samples and/or tests are required shall be used or covered until the Contract Administrator approves such samples and/or tests. If the Contractor installs, uses or covers any such material, article or work prior to testing and approval, such shall be at Contractor's sole risk and expense, and he shall bear all costs of uncovering, repair and replacement thereof.

Upon testing of any sample of material or work, no additional sample shall be considered.

Section 8.08. EFFECT OF SAMPLING AND TESTING.

The County assumes no obligation, and the Contractor shall be relieved of no obligation undertaken pursuant to the Agreement for Construction, by virtue of sampling and testing specified in this Article. The responsibility for incorporating satisfactory materials and workmanship, which meet the Contract Documents, into the Work rest entirely with the Contractor, notwithstanding any prior samples or tests.

The Contractor is not relieved of this obligation by virtue of the results of any test or the failure of the testing laboratory or consultant accurately to ascertain or report test results.

Section 8.09. CODE COMPLIANCE TESTING; COSTS.

The Contractor shall bear all costs for all sampling and/or testing required by all agencies of jurisdiction regarding compliance of the Work with the Codes those agencies enforce. Examples include but are not limited to Building, Fire, Health, Air Pollution, and CALOSHA Code and regulation and compliance testing.

The Contractor shall arrange for and conduct all such testing in conformity with applicable codes and regulations and shall schedule the testing so as not to delay the Work.



ARTICLE 9.

REJECTION AND REPLACEMENT OF WORK AND MATERIALS.

Section 9.01. REJECTION OF MATERIALS AND WORKMANSHIP.

The County shall reject materials that are determined by the Contract Administrator to be defective or fail to comply fully with the Contract Documents, and workmanship that is not first-class, competent and workmanlike in all respects. Rejected workmanship shall be corrected satisfactorily and rejected materials shall be removed from the premise and replaced, all without cost to the County.

Section 9.02. REMOVAL OF REJECTED MATERIALS.

The Contractor promptly shall remove from the Site all materials that have been rejected.

Upon request by the Contract Administrator, the Contractor shall submit a statement of the source for rejected materials. The County reserves the right to notify such source that the specified materials have not been and will not be incorporated into the Work, and no claim or stop notice therefore will be recognized. The Contractor shall fully indemnify the County for any claims, costs, or demands made by any supplier regarding such materials. The County reserves the right to satisfy any such supplier's claims by issuing a warrant jointly payable to the Contractor and the supplier, the amount of which shall be deducted from the next progress payment due to the Contractor.

Section 9.03. FAILURE TO REMOVE REJECTED MATERIALS.

If the Contractor does not remove rejected materials within a reasonable time, fixed by the written notice from the Contract Administrator, the County may remove such materials and may store or return the materials to the supplier, all at the expense of the Contractor. Contractor shall also bear the cost of replacement of any work damaged due to the removal of materials pursuant to this Section.

Any materials removed and stored pursuant to this section shall remain the property and the responsibility of the Contractor, and it is the Contractor's obligation to dispose of such materials. Such materials shall not again be brought upon the Site or any County-approved storage facility.

Section 9.04. FAILURE TO CORRECT REJECTED WORK; WITHHOLD AND DEDUCTION.

If the Contractor fails to correct rejected workmanship and/or materials, the County may withhold the cost to correct the rejected work, and the value of the rejected materials, from the Progress Payments due the Contractor.

If the work is not corrected prior to recordation of a Notice of Cessation or Notice of Completion, the County shall process a Contract Price Change Order to decrease the Contractor's final payment by an amount equal to the cost to cure the defect, measured by the cost the County would incur to purchase and install the specified material, and/or to correct the faulty workmanship, to bring the Work into full compliance with the Contract Documents.

Section 9.05. RESERVATION OF RIGHTS.

The County's authority to reject work under this Article is in addition to all other County rights under the Agreement for Construction. Neither the County's action or inaction under this Article shall relieve the Contractor from any obligation under this Agreement, nor constitute a waiver by the County of any other right under the Agreement for Construction.



ARTICLE 10.

SUPERVISION AND LABOR.

Section 10.01. SKILLED LABOR.

All labor shall be especially skilled for the kind of Work required, shall be conducted under the direction of a competent foreman, and workmanship shall be of the highest quality and finish, competent and workmanlike in all aspects.

All workers shall meet the skill and experience requirements specified in the applicable sections of the Technical Specifications.

Section 10.02. NO TENANCY.

All workers, contractors, or Contractor's representatives are admitted to the Site only for the proper execution of the Work and have no tenancy.

Section 10.03. DISMISSAL OF UNSATISFACTORY EMPLOYEES.

All employees engaged in the Work will be considered employees of the Contractor.

The Contractor shall discharge, or cause a subcontractor to discharge, any incompetent employee, any employee not skilled for the type of work required, or any employee who violated the standard set forth in Section 10.06 habitually or flagrantly.

Section 10.04. PERSONAL ATTENTION AND SUPERINTENDENCE; CONTRACTOR'S AGENT.

The Contractor shall supervise the Work to the end that it shall be faithfully prosecuted.

The Contractor at all times keep a Project Superintendent, fully empowered to act as agent for the Contractor, on the Site or available by telephone and within a reasonable distance. Contractor shall advise the County in writing of its agent, and of any limitations on the agent's authority to act on behalf of the Contractor. Regardless of such limitations, the Contractor shall be responsible for the faithful observation of all instructions delivered to it or its Project Superintendent, and representations on behalf of the Contractor by the Superintendent shall be binding on the Contractor.

Section 10.05. AUTHORIZED COUNTY VISITORS TO THE SITE.

The Contract Administrator shall specify those individuals who are entitled to access to the Site.

If the Contractor has complaints regarding the presence or conduct of any authorized individual on the Site, the Contractor shall report such complaint to the Contract Administrator, and shall conform to the instructions of the Contract Administrator regarding the complaint.

After consultation with the Contract Administrator, the Contractor may enforce reasonable regulations to secure the safety of authorized visitors. Such regulations may include the requirements to check in at a designated location and wear "hard hats" in specified areas.



Section 10.06. RELATIONSHIPS OF EMPLOYEES AND COUNTY EMPLOYEES AND THE PUBLIC.

It is the policy of the County of Yolo and the law of this State that all County employees be free from sexual, racial, or other harassment at their workplace; it is the policy of the County that all members of the public likewise be free there from.

It is Contractor's responsibility to supervise all workers on this Project to the end that their conduct does not result in a violation of this policy.

REMAINDER OF PAGE INTENTIONALLY LEFT BLANK

////////////////////////////////////



ARTICLE 11.

SUBCONTRACTORS; LISTING AND BID; SUBSTITUTION.

Section 11.01. SUBCONTRACTORS; CONTRACTOR'S SUPERVISION.

Nothing contained in the Agreement for Construction shall create any contractual relationship between any subcontractor and the County of Yolo. The County's only contract is with the Contractor.

The Contractor shall be as fully responsible to the County for the performance and/or omissions of all first-tier and lower-tier subcontractors and their employees and agents as it is for its own performance and omissions.

It is the Contractor's responsibility, not the County's, to resolve disputes between subcontractors and/or between the Contractor and subcontractors. The Contractor shall not simply refer issues raised by subcontractors to the Contract Administrator. Prior to referring any controversy, issue, or request made by any subcontractor to the County, the Contractor shall exert his good faith best efforts to resolve the issue. Upon referring any such request, the Contractor shall accompany it with a submittal specifying efforts taken by the Contractor to resolve the issue. Should the Contract Administrator determine that the Contractor has not satisfied his obligation pursuant to this section, the Contract Administrator may reject the Contractor's submittal. The Contractor shall not be entitled to either a Contract Price or a Contract Time Change Order as a result of such rejected submittal.

It is also the Contractor's responsibility to supervise all subcontractors' compliance with all safety, wage and hours, equal employment opportunity and related regulations, including reporting requirements.

The County shall not entertain any request for, nor engage in, arbitration or dispute resolution between subcontractors, subcontractors and the Contractor, nor any agency with Code compliance, safety, wage and hours, and/or equal employment opportunity jurisdiction. However, in the event of such dispute, the Contract Administrator may request the Contractor to provide a complete written explanation of all facts underlying the dispute and may attend or call any meetings between the disputing parties. The Contractor shall provide such information to the Contract Administrator upon his request.

The County shall not be liable to the Contractor for any claims by subcontractors, suppliers, laborers, workers, or any other person, including claims that are settled by and assigned to the Contractor. The Contractor shall indemnify, defend and hold harmless the County, its officers, agents and employees from and against any and all such claims.

Section 11.02. DISPUTES BETWEEN SUBCONTRACTORS AND/OR CONTRACTOR.

If, through acts of neglect on the part of the Contractor, including failure to supervise and control his subcontractors, any other contractor, subcontractor, or workman shall suffer loss or damage on the Work, Contractor agrees to settle with such other contractor, subcontractor, or workman by agreement or arbitration, if such other contractor, subcontractor, or workman shall assert any claim against the County of Yolo or any of its officers, agents, or employees, on account of any damage alleged to have been so sustained.

In the event of the receipt of any such claim, the County shall notify the Contractor, who shall defend, indemnify, and save harmless the County and all of its officers, agents, and employees against any such claim, pursuant to Section 2.05 hereof.



Section 11.03. LISTING OF SUBCONTRACTORS.

Contractor shall comply with the requirements in the Instructions to Bidders regarding the listing of subcontractors and shall comply with the requirements of the Subletting and Subcontracting Fair Practices Act, Public Contracts Code Sections 4100 and following, forbidding bid shopping and bid peddling and requiring accurate listing of all subcontractors.

Should the Contractor violate any provision of that Chapter, such violation shall be deemed a breach of the Agreement for Construction, and the County shall have all remedies provided by California law including, but not limited to, those provided in Public Contracts Code Section 4110, allowing termination of the Contract or a penalty assessment of 10% of the subcontract.

Section 11.04. TERMINATION OF UNSATISFACTORY SUBCONTRACTORS.

When any portion of the Work that has been subcontracted by the Contractor is not being prosecuted in a satisfactory manner, the Contractor shall terminate the subcontract for such work.

Any such subcontractor who is discharged shall not again be employed on the Project.

Any termination of a subcontractor pursuant to this section shall be in strict conformity with the Subletting and Subcontracting Fair Practices Act, Public Contracts Code Sections 4100 and following.

Section 11.05. SUBCONTRACTORS' INSURANCE.

All subcontractors shall procure and maintain the insurance required by Article 2 hereof. Contractor shall supervise subcontractors to enforce this requirement and shall allow no subcontractor to evade this requirement.

REMAINDER OF PAGE INTENTIONALLY LEFT BLANK
////////////////////////////////////



ARTICLE 12.

**STATE REQUIREMENTS REGARDING WAGES, HOURS,
AND EQUAL OPPORTUNITY.**

Section 12.01. PREVAILING WAGE RATE NOTICE

As provided under Labor Code Sections 1726-1861, the Director of the Department of Industrial Relations (DIR) of the State of California has determined the prevailing rate of wages in the locality in which the Work on the project is to be performed for each craft, classification, or type of Worker needed to execute this Contract. The prevailing rates so determined are on file with the COUNTY, and they are available for public inspection. They may also be obtained on the internet at http://www.dir.ca.gov/DIR/S&R/statistics_research.html. Those prevailing wage rates hereby are incorporated in this agreement and made a part hereof.

The CONTRACTOR shall obtain and post copies of these prevailing wage rates in a prominent place at the job site, in accordance with the regulations of the Department of Industrial Relations.

If the Project is subject to the requirements of Title 8 of the California Code of Regulations, Section 16461, the CONTRACTOR shall post on the jobsite a Notice containing the following language:

DIR will no longer charge awarding bodies for prevailing wage compliance monitoring and enforcement by the CMU.

SB 854 (2014) established a public Works CONTRACTOR registration program to replace prior Compliance Monitoring Unit (CMU) and Labor Compliance Program (LCP) requirements for bond-funded and other specified public Works projects.

- Pursuant to Labor Code section 1725.5 and 1771.3, contractors and subcontractors who intend to bid on, be listed in a bid proposal, or enter into a contract to perform public work must be registered with the Department of Industrial Relations. No proposal will be accepted nor any contract entered into without proof of the contractor's and subcontractors' current registration with the Department of Industrial Relations to perform public work. CONTRACTOR and its subcontractors, of any tier, shall maintain active registration with the Department of Industrial Relations for the duration of the project. Information is available at: <http://www.dir.ca.gov/Public-Works/PublicWorks.html>. This project is subject to compliance monitoring and enforcement by the Department of Industrial Relations. In bidding on this Project, it shall be CONTRACTOR's sole responsibility to evaluate and comply with all labor compliance requirements and applicable laws in performing the Agreement for Construction.

Section 12.02. PAYMENT OF PREVAILING WAGE RATES.

Pursuant to Labor Code Section 1772, Workers employed by contractors or subcontractors in the execution of any contract for public Work are deemed to be employed upon public Work as defined in Labor Code Sections 1720-1725. Therefore, the CONTRACTOR shall pay, and shall cause all subcontractors, whether under contract with the CONTRACTOR or under contract with any subcontractor, to pay not less than the specified prevailing wage rates to all Workers employed in the execution of this Contract.

In accordance with Labor Code Section 1775, the CONTRACTOR shall monitor the payment of the specified general prevailing rate of per diem wages by subcontractors to employees by periodic review of the certified payrolls of the Subcontractors.

Section 12.03. WAGE RATES FOR CRAFTS NOT LISTED.

The responsibility to check prevailing wage rates is the CONTRACTOR's. Pursuant to Labor Code Section 1773, the CONTRACTOR may file with the Director of DIR or the Chief of the Division of Labor Standards Enforcement ("DLSE") a petition to review a determination of any rate or rates made by the Director of DIR. The CONTRACTOR may also petition the Director of DIR to make a determination for a particular craft, classification or type of Work not covered by a general determination. Pending the review or



determination, the wages may be assumed to be those in the applicable collective bargaining agreement, but no adjustment in the bid or Contract Price shall be made if such assumption is incorrect.

Section 12.04 RECORDS OF HOURS WORKED AND WAGES

The CONTRACTOR shall keep, and shall cause all subcontractors on the Project to keep, certified payroll records of the hours and wages of all employees employed on the Project, and those records shall be open at all times for inspection by the COUNTY and/or the Division of Labor Statistics and Enforcement, in accordance with Sections 1776 and 1812 of the Labor Code. The certified payroll records shall contain at least the following information: the name, address, social security number, Work classification, dates of payroll period, straight time, and overtime hours Worked each day and week, and the actual per diem wages paid to each journeyman, apprentice, Worker, or other employee employed by the CONTRACTOR and/or each Subcontractor in connection with the Work.

In the event that the CONTRACTOR and/or any subcontractor fails to submit certified payroll records to the COUNTY within ten (10) calendar days of a request from the COUNTY for the records, the CONTRACTOR and/or the Subcontractor shall, as a penalty, forfeit one hundred dollars (\$100) per calendar day, per Worker, until strict compliance is effectuated. These penalties shall be withheld from progress payments then due and/or to become due. The CONTRACTOR is not subject to this penalty assessment due to the failure of a Subcontractor to comply with these requirements if the CONTRACTOR can demonstrate that it has fully complied with the provisions of Labor Code Section 1776.

The CONTRACTOR shall not carry on its payrolls any person not actually employed by the CONTRACTOR, nor shall it carry on its payroll's employees of any Subcontractor. The CONTRACTOR shall show on its payrolls all persons actually employed by the CONTRACTOR on the Project, in any capacity. The CONTRACTOR shall cause all subcontractors on the Project, whether under contract with the CONTRACTOR or under contract with any subcontractor, to comply with this Section.

In accordance with Government Code Section 8546.7, or any amendments thereto, all books, records, and files of the CONTRACTOR, or any subcontractor connected with the performance of this Contract, shall be subject to examination and audit by the Auditor General for a period of three (3) years after final payment. CONTRACTOR shall preserve and cause all Subcontractors to preserve such books, records and files for the audit period.

Section 12.05. ADDITIONAL REQUIREMENTS FOR LABOR COMPLIANCE

In accordance with Section 16463 of Title 8 of the California Code of Regulations ("8 CCR Section 16463"), the COUNTY may, on its own or if required by the Labor Commissioner, withhold funds due to the CONTRACTOR when payroll records are delinquent or inadequate. The amount withheld shall be those payments due or estimated to be due to the CONTRACTOR or subcontractor whose payroll records are delinquent or inadequate, plus any additional amount that the Labor Commissioner has reasonable cause to believe may be needed to cover a back wage and penalty assessment against the CONTRACTOR or subcontractor whose payroll records are delinquent or inadequate. The CONTRACTOR shall cease all payments to a Subcontractor whose payroll records are delinquent or inadequate until the Labor Commissioner provides notice that the Subcontractor has cured the delinquency or deficiency. When payments are withheld under 8 CCR Section 16463, the Labor Commissioner will provide the CONTRACTOR and Subcontractor, if applicable, with immediate written notice that includes all of the following: (1) a statement that payments are being withheld due to delinquent or inadequate payroll records, and that identifies what records are missing or states why records that have been submitted are deemed inadequate; (2) specifies what amounts the CONTRACTOR has been directed to withhold; and (3) informs the CONTRACTOR or subcontractor of the right to request an expedited hearing to review the withholding of payments under Labor Code Section 1742, limited to the issue of whether the records are delinquent or inadequate or the Labor Commissioner has exceeded his or her authority under 8 CCR Section 16463. The withholdings under 8 CCR Section 16463 do not preclude assessment of penalties under Labor Code Section 1776(g) for failure to timely comply with a written request for certified payroll records, as set forth below.



Section 12.06 UNDERPAYMENT OF WAGES

The CONTRACTOR agrees that in the event of underpayment of wages to any employee on the Project, whether by the CONTRACTOR or any subcontractor on the Project, the COUNTY may retain from payments due to the CONTRACTOR, an amount sufficient to pay such Worker the difference between the wages required to be paid by the DIR, and the wages actually paid such Worker for the total number of hours Worked, plus any penalties and forfeitures. The COUNTY may disburse such retention to such employees.

Section 12.07. APPRENTICES.

Attention is directed to the provisions of Sections 1777.5, 1777.6 and 1777.7 of the Labor Code concerning the employment of apprentices by the CONTRACTOR or any subcontractor.

The CONTRACTOR and all subcontractors on the Project shall comply with the requirements of Sections 1777.5 and Section 1777.6 of the Labor Code in the employment of apprentices. Violation of these requirements shall subject the CONTRACTOR and/or subcontractor to the penalties set forth in Section 1777.7 of the Labor Code and/or otherwise provided by law or Contract.

Information relative to apprentice standards, wage schedules, and other requirements may be obtained from the Director of Industrial Relations, ex-officio the Administrator of Apprenticeship, San Francisco, California, from the Division of Apprenticeship Standards or its branch offices, and/or on the DLSR website at www.dir.ca.gov/DLSR/PWD. Apprentices employed on the Project must at all times Work with or be under the direct supervision of a journeyman or journeymen.

Section 12.08 PENALTIES

In accordance with Articles 2 and 3, Chapter 1, Part 7, Division 2 of the Labor Code, particularly Sections 1775, 1776, 1777.7 and 1813, the CONTRACTOR shall forfeit to COUNTY as a penalty the sum specified below, over and above any retention or withholds otherwise authorized by the agreement, as follows:

- A. Up to two hundred dollars (\$200) for each calendar day, or portion thereof, for each Worker paid less than the applicable prevailing wages for any Work done by him/her under this Contract or under any subcontract on the Project, with the amount to be determined by the Labor Commissioner in accordance with the considerations set forth in Labor Code section 1775. If a Worker employed by a Subcontractor on the Project is paid less than the prevailing wages by the Subcontractor, the CONTRACTOR is not subject to this penalty assessment if the CONTRACTOR can demonstrate that it did not have knowledge of that failure of the Subcontractor to pay the prevailing wages and that it strictly complied with the requirements of Labor Code Section 1775(b).
- B. Twenty-five dollars (\$25) for each Worker employed in the execution of this agreement by the CONTRACTOR or by any Subcontractor on the Project for each calendar day during which such Worker is required or permitted to Work more than eight (8) hours in any one calendar day and forty (40) hours in any one calendar week in violation of the provisions of Article 3.
- C. Failure to provide certified payroll records to the COUNTY or, if applicable, to the CMU, within ten (10) calendar days of a request, shall, in addition to resulting in a withholding of payments due or estimated to be due, result in a penalty in the amount of one hundred dollars (\$100) for each calendar day, or portion thereof, for each Worker until strict compliance is effectuated. The CONTRACTOR is not subject to this penalty assessment due to the failure of a Subcontractor to comply with these requirements if the CONTRACTOR can demonstrate that it has fully complied with the provisions of Labor Code Section 1776.
- D. Knowing violation of Labor Code Section 1777.5 shall yield a penalty in an amount not exceeding one hundred dollars (\$100) for each full calendar day of non-compliance. A CONTRACTOR or Subcontractor who knowingly commits a second or subsequent violation of Section 1777.5 within a



three-year period, where noncompliance results in apprenticeship training not being provided as required, shall forfeit as a civil penalty the sum of no more than three hundred dollars (\$300) for each full calendar day of noncompliance.

Section 12.09. HOURS OF WORK AND APPROVAL OF SCHEDULES

Eight (8) hours of labor constitutes a legal day’s Work, and forty (40) hours constitutes a legal Work week. No Worker employed at any time by the CONTRACTOR, or by any subcontractor upon the Project, shall be required or permitted to Work more than eight (8) hours in any one calendar day or forty (40) hours in any one week, except as provided in Labor Code Sections 1810 through 1815.

Overtime shall be paid at the rate of not less than one and one-half (1-1/2) times the basic rate of pay, or at such other rate as stated on the applicable Determination issued by the DIR, or as may be required by applicable statutes or collective bargaining agreements.

The COUNTY reserves the right to approve or disapprove the days scheduled for Work, and the hours during which Work is in progress.

Section 12.10. COMPLIANCE WITH THE STATE ANTI-DISCRIMINATION LAWS

The CONTRACTOR shall comply with Section 1735 of the Labor Code, which provides as follows:

“A contractor shall not discriminate in the employment of persons upon public works on any basis listed in subdivision (a) of Section 12940 of the Government Code, as those bases are defined in Sections 12926 and 12926.1 of the Government Code, except as otherwise provided in Section 12940 of the Government Code. Every contractor for public Works who violates this section is subject to all the penalties imposed for a violation of this chapter.”

REMAINDER OF PAGE INTENTIONALLY LEFT BLANK
////////////////////////////////////



ARTICLE 13.

**FEDERAL REQUIREMENTS REGARDING WAGES, HOURS,
AND EQUAL OPPORTUNITY**

SEE SUPPLEMENTARY CONDITIONS



ARTICLE 14.

ON-SITE SECURITY; RISK OF LOSS; SITE SAFETY.

Section 14.01. PROJECT SITE.

The Contractor shall confine his equipment, materials, and construction apparatus to the site limits designated in the Contract Documents and/or directed by the Contract Administrator.

The Site and equipment storage areas shall be kept in a neat and safe condition, conforming to all requirements of the Contract Documents and applicable Codes regarding the storage of materials, including flammable materials.

Section 14.02. SECURITY OF THE SITE.

The Contractor shall take such steps as are necessary to secure the Site at all times, including times workmen are not present. The Contractor shall maintain adequate security and protection of all structures, facilities, equipment, tools, materials, and any other property on or adjacent to the Site, against damage, vandalism, loss of fire, or theft.

The Contractor's attention is directed to the Technical Specifications and/or Supplementary Condition for specified fencing, screening, gate and lighting requirements, if any.

The Contractor may, at its option and expense, provide night watchmen for the Site. The facilities for such watchmen shall be subject to approval by all agencies with jurisdiction.

At the Contract Administrator's request, the Contractor shall meet with representatives of the police and fire agencies with jurisdiction and shall comply with the Contract Administrator's request on behalf of such departments regarding security of the Site.

Section 14.03. RISK OF LOSS.

The Contractor assumes full responsibility for site security and full liability for the risk of loss from any cause of materials stored, work performed and existing improvements on the site, and agrees to repair and replace, at no cost to the County, at the time they are needed for incorporation in the Work, any materials or work that may have become lost, damaged, destroyed, stolen, vandalized, or have otherwise been rendered unsuitable for use from any cause. Contractor shall repair or replace any such damage and remove any damaged or defaced materials and/or equipment from the Project Site, at no cost to the County, and Article 9 hereof shall apply to such material or equipment.

Section 14.04. PROTECTION OF WORKMEN AND VISITORS TO THE SITE.

Contractor shall take all necessary precautions for the safety of all employees and visitors to the Site and shall comply with all applicable provisions of the Federal, State and local safety laws and building codes to prevent accidents or injury to persons on, about, or adjacent to the Site.

Contractor shall erect and properly maintain at all times, as required by the condition and progress of the Work, all necessary safeguards for the protection of workmen, visitors to the Site, and the public, and shall post danger signs warning against construction hazards as needed.

The responsibility for maintaining a safe site shall be the Contractor's and the County undertakes no obligation to suspend the Work or notify the Contractor of any hazardous condition or noncompliance with safety laws.

Contractor shall designate a responsible member of his organization on the Work, whose duty shall be the prevention of accidents. The name and position of persons so designated shall be reported to the



Contract Administrator by the Contractor; absent designation of some other individual by the Contractor, the Contractor's Project superintendent shall be responsible for the Contractor's safety program.

Contractor shall immediately replace or repair any unsafe, dangerous, or hazardous condition that may exist.

Section 14.05. EXCAVATION AND TRENCHING; SAFETY.

The Contractor shall comply with of all provisions of law regarding safety requirements for trenches or excavations.

A. Public Contract Code '7104 provides:

(a) That the contractor shall promptly, and before the following conditions are disturbed, notify the public entity, in writing, of any: (1) Material that the contractor believes may be material that is hazardous waste, as defined in Section 25117 of the Health and Safety Code, that is required to be removed to a Class I, Class II, or Class III disposal site in accordance with provisions of existing law; (2) Subsurface or latent physical conditions at the site differing from those indicated; (3) Unknown physical conditions at the site of any unusual nature, different materially from those ordinarily encountered and generally recognized as inherent in work of the character provided for in the contract.

(b) That the public entity shall promptly investigate the conditions, and if it finds that the conditions do materially so differ, or do involve hazardous waste, and cause a decrease or increase in the contractor's cost of, or the time required for, performance of any part of the work shall issue a change order under the procedures described in the contract.

(c) That, in the event that a dispute arises between the public entity and the contractor whether the conditions materially differ, or involve hazardous waste, or cause a decrease or increase in the contractor's cost of, or time required for, performance of any part of the work, the contractor shall not be excused from any scheduled completion date provided for by the contract, but shall proceed with all work to be performed under the contract.

B. Labor Code Section 6705 provides that in advance of any excavation of any trench or trenches or other excavation five (5) feet or more in depth, the Contractor shall submit a detailed plan to the Contract Administrator for information only showing the design of shoring, bracing, sloping or other provisions to be made for worker protection from the hazard of caving ground during the excavation of such trench or trenches. If such plan varies from California State Shoring System standards, the plan shall be prepared by a registered civil or structural engineer.

C. Nothing in the Contract Documents shall be deemed to allow the use of a shoring, sloping, or protective system less effective than that required by the Construction Safety Orders of the State of California.

Nothing in this Section shall be construed to impose liability on the County of Yolo or any of its officers, agents, or employees, or to relieve the Contractor of its obligations to provide a safe site.



Section 14.06. CAL OSHA.

The contractor shall comply with all requirements of the California Occupational Safety and Health Administration or its successor, and the Federal equivalent, and shall provide a safe work environment for all workers employed on the Work, as required by such agencies. The Contractor shall supervise performance of the Work with all occupational health & safety requirements applicable to the type of work being done, and the materials and equipment being utilized. (See also Section 20.05).

REMAINDER OF PAGE INTENTIONALLY LEFT BLANK

////////////////////////////////////



ARTICLE 15.

OFF-SITE SAFETY AND PROTECTION OF ADJACENT PROPERTY; INDEMNITY.

Section 15.01. PROTECTION OF ADJACENT PROPERTY DURING EXCAVATION OR OTHER OPERATIONS; NOTICES.

In addition to any requirements imposed by law, the Contractor shall shore up, brace, underpin, and protect as may be necessary all foundations and other parts of all existing structures on the Site or adjacent to the site which are in any way affected by the excavations or other operations connected with performance of the Work.

Not less than five (5) days prior to commencing any work which may detrimentally affect adjoining or adjacent land or buildings thereon, the contractor shall send the owner and occupants thereof a notice, which specifies the type of Work to be done, the schedule of the Work, the effects expected from the Work, and the protective measures being taken by the Contractor. A copy of the notice shall be sent to the Contractor Administrator.

The basic standard to determine whether the Work may detrimentally effect adjoining properties shall be whether the work will create noise, dust, vibration, and/or settling on such properties. Examples include, but are not limited to, blasting, pile driving and excavations within 30 feet of any structure not owned by the County.

The Contractor shall, at the instruction of the Contract Administrator, meet with any recipient of such notice to explain and discuss the proposed Work. The Contractor shall make such modifications to the proposed working methods as are required to comply with all provisions of law, and shall exert its best efforts to address the concerns expressed by recipients of such notices.

Section 15.02. UNDERGROUND UTILITIES; "USA".

The Contractor is responsible to coordinate all excavation work with the owners of existing underground utilities, and to avoid unintentional disruptions in services by those utilities. Locations of existing utilities shown on the Contract Drawings are schematic only and shall not relieve the Contractor's duty to precisely locate and avoid them.

If the underground utility service is disrupted by the Work, the Contractor shall take emergency action appropriate to the situation and immediately notify the owner of the utility. Repair thereof shall be the Contractor's responsibility, at no cost to the County.

The Contractor is advised that the County participates in the Underground Service Alert-Northern California ("USA"), which may be contacted by telephone at (800) 227-2600. Except in an emergency, the Contractor shall contact the USA Notification center at least two working days prior to commencing an excavation in any area that contains subsurface installations.

Section 15.03. DAMAGE TO OR BLOCKING STREETS, STREET IMPROVEMENTS AND TRACKS.

The Contractor is responsible to avoid damage to existing streets, sidewalks, curbs, traffic signs and signals, streetlights, control boxes, meters, railroad tracks, crossing guards, and all other appurtenances thereto. The Contractor shall take necessary precautions to avoid damage to such property, and if damage occurs, shall take emergency action appropriate to the situation and immediately notify the owner of the damaged property. Repair thereof shall be the Contractor's responsibility, at no cost to the County.



Existing traffic signs, lights, traffic signals, railroad crossing warnings, control boxes, hydrants, meters and related safety items occurring within the street and/or sidewalk area shall be kept visible, free of obstructions and accessible at all times.

Should it be necessary to cover up, move, or alter such items, this shall be done only with permission of the authorities having jurisdiction of the items involved.

Should it be necessary to block a street or sidewalk, the Contractor shall first notify the police, fire, or public works agencies with Jurisdiction, and shall comply with their instructions, including scheduling limitations.

Section 15.04. FIRE PROTECTION.

The Contractor is responsible to protect all structures from fires and sparks originating in the work, and all laws and regulations regarding fire protection, and shall comply with all instructions of the fire department with jurisdiction.

The Contractor shall notify the Contract Administrator and the fire department prior to disconnection of either water or electrical service to the Site, and shall comply with the fire department's instructions regarding fire safety.

The Contractor shall provide fire extinguishers as necessary to protect the Site and adjacent structures at all times, in accordance with applicable Fire Codes, regulations and Fire Department instructions.

Section 15.05. DUST CONTROL.

The Contractor shall at all times control dust originating from the Site by sprinkling as needed. The Contractor shall not allow dust to be blown onto adjacent properties. In the event that complaints are received by the County regarding dust control, the Contractor shall increase sprinkling to control the dust.

Section 15.06. INDEMNITY FOR DAMAGE TO ADJACENT PROPERTY; REPAIRS.

- A. **Indemnity.** Without limitation of its indemnity obligations set forth in Article 3 hereof, Contractor shall defend, indemnify, and save harmless the County from any claim, loss or damages on account of any harm to person or property alleged to have resulted from the Work, the performance of this Agreement or Contractor's acts or omissions in protecting the public from the effects of the Work including settlement and/or the loss of lateral subjacent support of adjoining property; damage to utilities' or governmental agencies' equipment or installations; injuries to persons using the public streets; and from all loss or expense and from all damages for which the County may be liable as a consequence of such injury or damage to person an/or adjoining or adjacent property and/or structures' or equipment or installations, including those owned by Yolo County.
- B. **Repairs.** Any damage arising from or in consequence of the performance of the Agreement for Construction to tracks, pavement, curbs, sidewalks, walls, stairs, sewage and/or drainage structures, mains, pipes, valves, conduits, poles, wires, transformers, trees, shrubs, adjoining work, or to any other improvement or property above or below the surface of the ground, whether private or public, shall be repaired at once by Contractor without expense to the County, if the owner thereof consents.



Section 15.07. EMERGENCY SAFETY ACTIONS.

In an emergency affecting the safety of life or property, including adjoining property, the Contractor, without previous instructions or authorizations from the County, shall act at the Contractor's discretion and risk to prevent such threatened loss or injury, and shall bear all costs of such action. The Contractor immediately shall notify the Contract Administrator of such actions, and thereafter shall comply with any instructions issued by the Contractor Administrator.

REMAINDER OF PAGE INTENTIONALLY LEFT BLANK
////////////////////////////////////



ARTICLE 16.

CONDUCT AND PROSECUTION OF THE WORK.

Section 16.01. BASIC STANDARD.

The Contractor is responsible for all aspects of the full, complete, satisfactory and faithful performance of the Work strictly as specified by the Contract Documents or any duly issued amendments thereto as well as all applicable laws and regulations.

Section 16.02. SURVEYS AND FIELD ENGINEERING.

Unless otherwise specified, the Contractor is responsible for all survey and field engineering work required for performing the Work. All such survey and field engineering work shall conform to the Technical Specifications.

The County shall identify existing control points and property line corner stakes, as indicated on the Drawings. Benchmarks, baselines, property boundaries, line and grade hubs, and other reference and construction points shall thereafter be maintained by the Contractor who shall be responsible for keeping their accuracy and who shall pay all costs of re-establishing them if they are disturbed.

The Contractor shall notify the Contract Administrator in writing at least ten (10) days prior to the time he will commence work on any part of the construction requiring surveys to be commenced by the County.

Section 16.03. CLEARING OBSTRUCTIONS.

Unless specified otherwise, the Contractor shall clear all obstructions and prepare the site for the construction. The Contractor shall verify all dimensions and levels shown on the Drawings against the Site after it has been graded and prepare for construction, and properly reset all survey control points and property line corner stakes.

Section 16.04. LAYOUT WORK.

The Contractor shall be responsible for all layout work, and shall lay out all lines, corners, levels and grade stakes after the Site has been prepared. The exact locations of all partitions shall be laid out on forms, walls and flooring, as the Work progresses. It is the Contractor's responsibility to verify all dimensions shown on the Drawings before layout of the Work, and to properly locate the Project on the Site and the components within the structure, as specified by the Contract Documents.

Section 16.05. CONTRACTOR'S EQUIPMENT.

The Contractor shall provide adequate and suitable equipment and means of construction to meet all the requirements of the Contract Documents, including completion of the project within the time specified. The Contractor alone shall be responsible for the safety, adequacy, and efficiency of his plant, equipment and methods, and those of all subcontractors on the Site. By entering the Agreement for Construction, the Contractor agrees to provide all specialized plant, equipment and methods of construction required to perform the Work on schedule, whether separately specified or not, at no extra cost to the County.



Section 16.06. DISCOVERY OF UNKNOWN CONDITIONS; PROCEDURE.

Should concealed or unknown conditions be encountered in the performance of the work below the surface of the ground or in existing structures on the Site, which conditions are at variance with the Contract Documents, the Contractor immediately shall seek a Clarification from the Contract Administrator, pursuant to Section 4.08 hereof.

The Contract Administrator shall investigate, and if the Contractor has demonstrated the following, a Change Order shall be processed pursuant to Article 17:

- A. The conditions are at variance with the Contract Documents; and,
- B. The conditions require work beyond the Scope of the Agreement for Construction; and,
- C. The conditions differ materially and substantially from conditions normally encountered and generally recognized as inherent in work of the character of the Project in the area of the Project Site; and
- D. The Contractor has provided Notice of its claim as required by Section 17.05.

Time extensions necessitated by concealed conditions are governed by Section 3.07-D.

No claim for extra compensation or time for conditions described herein shall be allowed unless the Contractor has given the notice required by this Section and/or Section 3.08 hereof (regarding Notice of Delay). (See also: Section 4.04 regarding Site Conditions).

Section 16.07. EQUIPMENT AND METHODS.

Only equipment and methods suitable to produce the quality of Work required to conform to the Technical Specifications shall be permitted by the Contractor to operate on the Work. If any part of the Contractor's plan, equipment or methods of execution of the Work are determined by the Contract Administrator to be nonconforming to applicable safety regulations or to be non-conforming to applicable Technical Specifications, the Contract Administrator may order the Contractor to conform to the applicable requirements, and the Contractor shall promptly comply with such orders; provided, however, that neither compliance with such orders nor failure by the Contract Administrator to issue such orders shall relieve the Contractor from his obligation to perform the Work as required by the Contract Documents.

Section 16.08. TEMPORARY FACILITIES AND SERVICES.

The Contractor shall be responsible for providing and maintaining all necessary storage places, field offices, temporary roads, fences, and all utilities, including telephone, electric, gas and water service to the Site during construction at his sole cost and expense unless otherwise specified in the Technical specifications. The Contractor shall not connect to fire hydrants for construction water without the prior consent of the fire department with jurisdiction,

The Contractor shall comply with all requirements of Federal and State law and Yolo County Ordinances regarding the placement of temporary facilities on the Site, and the County shall not be deemed by this Agreement to have consented to such placement.

Section 16.09. COORDINATION OF WORK.

The Contractor shall be responsible for coordinating the work of the various subcontractors and trades employed on the Work. He shall adjust, correct, and coordinate this work with the work of others so that no discrepancies will result nor unnecessary delays occur.



If completion is delayed because of any acts or omissions of any subcontractors, the Contractor shall on that account have no claim against the County for extra compensation or time.

Section 16.10. JOINING WORK.

Where work of one trade or subcontractor joins or is installed upon the work of another trade or subcontractor, there shall be no discrepancy in mating or joining such work, which shall be done and finished in a good and workmanlike manner. In joining one kind of work with another, the marring or damaging of either shall be corrected at no expense to the County.

Should improper work of any trade be covered by that of another, it shall be the Contractor's responsibility to correct the improper work and to adjust costs between the various subcontractors, without cost to the County.

Section 16.11. CUTTING AND PATCHING OF WORK.

The Contractor shall be responsible for all cutting, fitting or patching that may be required to complete the work or to make its several parts fit together properly.

The Contractor shall not damage or endanger any portion of the Work or work being done by the County or any separate contractors by cutting, patching or otherwise altering any work, or by excavation. The Contractor shall not cut or otherwise alter the work of the County or any separate contractor except with the written consent of the Contract Administrator and of such separate contractor. The Contractor shall not unreasonably withhold from the County or any separate contractor his consent to cutting or otherwise altering the Work.

Section 16.12. INSPECTION OF THE WORK OF OTHER CONTRACTORS.

It shall be the duty of the Contractor and all subcontractors, before beginning any work, to examine all construction and work of other contractors and/or subcontractors that may affect their work, and to satisfy themselves that everything is in proper condition to receive such work.

Section 16.13. COMBINATION OF WORK WITH OTHER CONTRACTORS OR COUNTY.

If the Project requires performance of work by the County or other Prime Contractors, as specified in the supplementary Conditions, the following provisions shall apply:

- A. The County reserves the right to perform work related to the Project with its own forces, and/or to award separate contracts in connection with other portions of the Project or other work on the Site.



- B. When separate contracts are awarded for different portions of the Project or other Work on the Site, the term "Contractor" in the Contract Documents in each case shall mean the Contractor who executes each separate Agreement for Construction.
- C. The County will provide for the coordination of the work of its own forces and of each separate contractor with the Work of the Contractor, who shall cooperate therewith as provided below.
- D. The Contractor shall provide the County and separate contractors reasonable opportunity for the storage of their materials and equipment and the execution of their work on the site and shall connect and coordinate his Work with theirs as required by the Contract Documents. The Contract Administrator may designate separate areas on the Site for the use of separate contractors.
- E. If any part of the Contractor's Work depends for proper execution or results upon the work of the County or any separate contractor, the Contractor shall, prior to proceeding with the Work, promptly report to the Contract Administrator any apparent discrepancies or defects in such other work that render it unsuitable for such proper execution and results. Failure of the Contractor to report shall constitute an acceptance of the County's or separate contractor's work as fit and proper to receive his Work, except as to defects that may subsequently become apparent in such work by others.
- F. Any costs caused by defective or ill-timed work shall be borne by the party responsible, therefore.
- G. Should the Contractor unintentionally cause damage to the Work or property of the County, or to another contractor's work on the site, the Contractor shall, upon notice from the Contract Administrator, promptly attempt to settle with such other contractor by agreement, or otherwise to resolve the dispute. If such separate contractor sues or initiates a legal proceeding against the County on account of any damage alleged to have been caused by the Contractor, the County shall notify the Contractor who shall defend such proceedings, and if any judgment or award against the County arises therefrom, the Contractor shall pay or satisfy it and shall reimburse the County for all attorneys' fees and court or legal costs which the County has incurred.
- H. If a dispute arises between the Contractor and separate contractors as to their responsibility for cleaning up, the County may clean-up and charge the costs thereof to the contractors responsible therefore, as determined by the Contract Administrator.

Section 16.14. OVERTIME AND HOLIDAY WORK.

The Contractor shall secure the approval of the Contract Administrator before allowing work on the Project before 6:00 A.M. or after 6:00 P.M. on any working day, or any work on weekends or legal holidays.

The Contract Administrator may deny permission for such work, or impose conditions thereon, if needed to protect adjacent properties or land uses from noise, dust, or other work-related impacts not normally expected in the area during the terms proposed for such work. The Contract Administrator may consult with all governmental agencies with jurisdiction before responding to such requests.

The Contractor shall reimburse the County for all added costs to the County resulting from overtime and holiday work not specified by the Contract Documents, including Project Management and inspections by County employees and/or independent contractors, Project Architect cost increases, and any costs claimed



by any other contractor. Such reimbursement shall be made from the next progress payment due to Contractor.

Section 16.15. PROOF OF COMPLIANCE WITH CONTRACT DOCUMENTS AND LAW.

In order that the Contract Administrator may determine compliance with the requirements of the Contract Documents and applicable laws and regulations which are not readily ascertainable through inspection and tests of materials and work, the Contractor shall, at any time requested by the Contract Administrator, submit such documents or other satisfactory proofs as required by the Contract Administrator to demonstrate compliance by the Contractor with the Contract Documents and applicable laws and regulations.

REMAINDER OF PAGE INTENTIONALLY LEFT BLANK

////////////////////////////////////



ARTICLE 17.

CHANGE ORDERS; WORK AUTHORIZATIONS; ALLOWANCES.

Section 17.01. NO CHANGES WITHOUT CONSENT; PERFORMING WORK ORDERED.

No extra work shall be performed, and no change shall be made, except pursuant to a written Change Order or Work Authorization from the County stating that the extra work or change is authorized, and no claim for any addition to the Contract Price or Time for completion shall be valid unless so ordered; provided, however, that nothing in this Article shall excuse the Contractor from diligently proceeding and fully completing the Project.

Section 17.02. CHANGE ORDERS AUTHORIZED; PROCEDURE.

- A. **Change Orders Authorized.** Subject to legal requirements relating to competitive bidding, the County may require changes in, additions to, or deletions from the scope of the work to be performed or the materials to be furnished pursuant to the Contract Documents.
- B. **Methods of Calculation.** Adjustments, if any, to the Contract Price by reason of any such change, addition or deletion, shall be determined by one or more of the following methods, at the County's sole discretion. The Contractor shall provide sufficient substantiating data to allow the County to evaluate the Contractor's claim for a Change Order.
1. By a lump sum proposal from the Contractor accepted by formal action by the County; and/or
 2. By unit prices contained in the Contractor's original bid and incorporated in the Contract Documents or fixed by subsequent agreement between the County and the Contractor; and/or
 3. By time and materials charges if approved by formal action of the County, limited to the "Actual Cost" to perform the Work, as defined by Paragraph "D" of this Section, plus overhead and profit as allowed by Paragraph "C" of this Section.
 4. If the Change Order implements an Allowance procedure, the Contract Price adjustment shall be as specified in the Allowance.
- C. **Overhead and Profit on Change Orders.** The maximum amount allowable on any change order for overhead and profit shall not exceed the following:
1. For change order work performed by the prime contractor, the maximum amount for overhead and profit shall be the following percentages of the "actual cost to perform the work" as defined in Paragraph D of this Section, plus a maximum of 1% of such costs for extra bond premiums, upon submission of a paid invoice for such premiums:
 - a. If the change order is up to \$1,000.99, 20%;
 - b. If the change order is up to \$1,001.00 and \$4,000.99, 15%;



- c. If the change order is between \$4001.00 and \$12,000.99, 12%;
 - d. If the change order is \$12,001.00 or more, 10%.
2. For change order work performed by subcontractors, the maximum amount for all subcontractors' overhead and profit shall not exceed the percentages set forth in Subparagraph (1) above. The prime contractor may add 5% for the prime contractor's overhead and profit, and 1% for bond premiums if a paid invoice for extra bond premiums is submitted, both percentages being of the "actual cost" as defined in Paragraph B.
 3. The allowances for overhead and profit as enumerated in the preceding subparagraphs shall include full compensation for any and all items of overhead including superintendence, layout, field engineering, and any related work, whether or not included within the definition of "actual cost" specified in Paragraph D.
- D. **"Actual Costs" Defined.** The actual cost to perform the Work for purposes of this Section is limited to the applicable labor rates set forth in Article 12 hereof, including Contractor's contributions directly attributable to the Work authorized; and the material man's or supplier's invoice amount for all material and equipment actually used to accomplish the work authorized. All other direct and indirect costs, all costs attributable to the time needed to perform the work ordered by such Change Orders, and all profit associated with such work shall be included in the maximum overhead and profit amounts stated hereinabove.
- E. **Audit and Verification.** All Change Order claims are subject to examination and audit before payment, if ordered by the Contract Administrator. If requested by the Contract Administrator, the Contractor shall furnish a detailed itemized breakdown and copies of all invoices for all costs being claimed for such Change Order, prior to the Contract Administrator's decision thereon. The Contract Administrator may order a more detailed audit of the Contractor's claim and supporting documentation if necessary to decide the claim.
- F. **Deductive Change Orders.** If a Substitution, Field Order, Work Authorization, or Change Order is issued which reduces either the Scope of the Contract, the cost to perform the Work, the time to perform the work, or any combination thereof, the County shall be credited therefore on a Change Order. The credit shall be calculated in the same method as an extra-work Change Order. The Contractor shall submit time and materials data for approval by the Contract Administrator detailing the credit due the County. The County reserves the right to verify such data by reference to standard estimating manuals, the Contractor's Schedule of Values, or other documents, and to review the Contractor's estimate of the credit due.
- G. **Periodic Change Orders.** The Contract Administrator is authorized to cumulate Work Authorizations and to process periodic Change Orders including additions and deletions, and to develop procedures providing the methods for such processing in addition to and consistent with those set forth in Division I.



Section 17.03. WORK AUTHORIZATIONS; PROCEDURE.

- A. **Work Authorization Authorized.** The Contract Administrator or the County Administrative Officer, depending on amount, is authorized to issue Work Authorizations instructing the Contractor to proceed with extra work subject to the following maximum amounts, above which a Change Order must be approved by the Board of Supervisors.
- B. **Maximum Amounts.** Work Authorizations may be issued by the Contract Administrator up to \$2,000.99, and by the County Administrative Officer up to \$25,000, maximum price adjustment authorized thereby. Either may approve a time allocation for such work, subject to the procedure and limitations specified in Section 3.07-D.
- C. **Quotation by Contractor.** Other than in extraordinary circumstances as described below, before a Work Authorization is issued the Contractor shall submit a quotation setting forth an estimated cost of the extra work to be performed with sufficient substantiating data to allow the County to evaluate the quotation, and an estimate of the time necessary to perform the extra work. If requested by the Contract Administrator, the Contractor shall provide additional data to support the quotation. The Contractor shall acknowledge the quotation as binding.
- D. **Claim for Price Adjustment.** After the extra work specified on the Work Authorization is completed, the Contractor may submit a claim for a Contract Price Change Order due to the Work Authorization. The claim shall be supported with substantiating data to show the actual costs to perform the Work and the overhead and profit being claimed, as defined in Section 17.02 C and D. The maximum price adjustment claimed shall not exceed one-hundred-ten (110%) percent of the approved quotation.
- E. **Claim for Time Adjustment.** If the Contractor claims that the Work Authorization has delayed the Contract Completion Time, he shall verify the claimed delay by demonstrating with reference to the approved Project Progress Schedule that the Work Authorization in fact caused a delay in the overall completion date of the Project. Upon such demonstration, the Contract Administrator shall process a request for a Contract Time extension Change Order pursuant to Article 3 hereof.
- F. **Accumulation of Work Authorizations.** At the Contract Administrator's sole discretion, the Contractor's claims for change Orders arising from several Work Authorizations may be accumulated into periodic Change Orders adjusting Contract Price, Time, or both, separately or in one Change Order.

Such periodic Change Orders shall include deductions for Changes that constitute Deductive Change Orders, as defined in Section 17.02-F during the time period being considered in the periodic Change Order.

- G. **Immediate Work Authorizations.** In the event extraordinary circumstances arise which require extra work to be authorized before a quotation is prepared by the Contractor, the Contract Administrator or County Administrative Officer may issue an immediate Work Authorization without such quotation. Such Work Authorization shall include a maximum authorized sum over which no price adjustment will be authorized. The determination as to whether circumstances as



described above exist is discretionary with the County. Such Work Authorizations otherwise shall be processed as specified in this Section.

Section 17.04. EXTRA WORK CLAIMS; PROCEDURE.

If the Contractor claims that any Clarification or other instruction issued by the County requires work beyond the scope of the Agreement for Construction, the following provisions shall apply:

- A. **Notice to Contract Administrator.** The Contractor shall notify the Contract Administrator of its claim, and submit a quotation for the claimed costs, in the same manner as specified in Section 17.03-C. The Contractor shall submit additional information requested by the Contract Administrator to decide the claim.
- B. **Action by Contract Administrator.** The Contract Administrator shall review the Contractor's submittals and either approve or deny the Contractor's claim. The Contract Administrator shall issue his decision within twenty-one (21) days of receipt of a complete submittal from the Contractor. If the claim is approved, the Contract Administrator may process either a Change Order or Work Authorization, pursuant to this Article. If the claim is denied, the Contract Administrator shall so advise the Contractor. Thereafter, the Contractor shall proceed with the work in issue.
- C. **Time.** If the claim is approved, the time during which the claim was being considered shall be included in the time allocation for the Work Authorization adjusting the claim, and Section 17.02 shall apply thereto; if the claim is adjusted by Change Order, any Time extension authorized thereby shall include the time during which the claim was pending. If the claim is denied, no time adjustment shall be authorized.
- D. **Effect of Proceeding.** If the Contractor proceeds with the work without notifying the Contract Administrator pursuant to Paragraph A, or before a decision pursuant to Paragraph B, any claim for a Contract price and/or time adjustment shall be waived.
- E. **Scheduling.** The Contractor is responsible to schedule the work and submit extra-work claims so the time required for decision, as specified in Paragraph B, does not delay the Work in general.

Section 17.05. ALLOWANCES; PROCEDURE.

The Contractor's bid includes the amounts specified for Allowances in the Contract Documents. Work or materials specified as included in the Allowance shall be provided by the Contractor for the Allowance amount.

The County reserves the right to specify work and/or materials which differ from those specified as included in the Allowance, in which case additive or deductive changes to the Contract Price shall be processed pursuant to this Section.

Unless otherwise expressly specified in the Contract Documents, the following provisions shall control the Price adjustment for the Allowance:

- A. The Contract Price bid by the Contractor shall include the cost for the Allowance item(s), delivered to the Site, unloading, handling, storage, taxes, and all overhead and profit pertaining thereto. If the



Allowance is specified as including labor, the Contract Price bid by the Contractor shall include all costs of such labor, including superintendence, overhead and profit.

- B. If the County orders item (s) or labor different from those specified as included in the Allowance, the Contract Price shall be adjusted by either a deductive or additive Change Order pursuant to Section 17.02, or a Work Authorization pursuant to Section 17.03.
- C. Unless another method is specified by the Allowance, the price adjustment shall be based upon the following:
1. The actual costs of the items ordered by the County, delivered to the Site and made ready for incorporation in the Project shall be compared to the material cost specified in the Allowance. "Actual costs" is defined by Section 17.02-D.
 2. The actual costs of labor to incorporate the items ordered by the County in the Project shall be compared to the labor amounts specified in the allowance, if any. "Actual Costs" is defined by Section 17.02-D.
 3. The results of the materials and labor adjustments shall then be compared. If the net adjustment resulting from this comparison is additive, the Contractor shall be entitled to overhead and profit as specified by Section 17.02-D only on the net amount resulting from the previous calculations. Such overhead and profit shall include all sums authorized for all indirect costs associated with the Allowance, including materials, shipping, handling, unloading and storage and labor superintendence. If the net adjustment is negative, nothing shall be deducted for overhead and/or profit.
 4. The resulting adjustment shall either be reflected in a separate Change Order or cumulated in a periodic Change Order, at the Contract Administrator's sole discretion.
 5. Any Contract Time adjustment claimed by the Contractor shall be subject to Section 3.07.

Section 17.06. MINOR CHANGE ORDERS BY COUNTY ADMINISTRATIVE OFFICER.

The Yolo County Board of Supervisors has authorized the County Administrative Officer to order changes or additions in the work being performed under construction contracts, pursuant to Public Contracts Code Section 20142,

This authorization allows any change or addition in the Work to be ordered in writing by the County Administrative Officer when the extra cost to the County does not exceed the sum of TWENTY-FIVE-THOUSAND DOLLARS (\$25,000) plus 5% of the amount of the contract in excess of \$250,000.00, up to 10% of the Contract Price, whichever is less.

Section 17.07. CHANGE ORDERS REGARDING TIME FOR COMPLETION.

Any time extension authorized by the County pursuant to Article 3 hereof shall be set forth in a Change Order issued by the County Administrator.

Section 17.08. CHANGE ORDERS DUE TO UNAVAILABLE MATERIALS.



In the event that the Contractor demonstrates good cause for a delay in the Contract Time due to the unavailability of materials, the County, in its sole discretion, may either grant a Contract Time extension change order pursuant to Section 3.07-A hereof, or utilize this Section.

In the event that the Project is unable to be completed due to unavailable materials, and if the Project is complete otherwise, the Contractor may request to delete the portion of the Project not yet completed from the Agreement for Construction, thereby allowing a Notice of Completion to be filed on the remainder of the Project. The County shall approve no such Change Order unless the Contractor accompanies his request with an offer to perform the work so deleted for a price not to exceed the value of the work deleted by such Change Order, such work to be commenced upon delivery of the materials, and diligently prosecuted to completion. In the event the County elects to accept the Contractor's offer, work done pursuant thereto shall not be construed as work done on the Project, nor shall such work be construed as affecting, in any way, the legal significance of the Notice of Completion filed on the Project.

The application of this Section is limited as follows:

- A. No Change Order shall be issued pursuant to this Section until the Contractor has submitted all documents required for final payment.
- B. This Section shall apply only to work the Completion of which is precluded due to unavailable materials.
- C. Utilization of this Section lies solely within the discretion of the County, and such discretion hereby is delegated to the Contract Administrator.

Section 17.09. EFFECT OF CONTRACTOR'S ACCEPTANCE OF CHANGE ORDER.

By acceptance of a Change Order, Contractor agrees to the changes, if any, in the Contract Price specified for each item and to the specified extension of Time allowed, if any, for completion of the entire work on account of such Change Order, and agrees to furnish all labor and materials and perform all work necessary to complete all additional work specified therein for the price adjustment and within the time specified therein. Contractor shall make no additional claim for adjustment to the Contract Price or Time, nor for additional costs or damages, on account of the Work referenced in such Change Order. A Change Order duly issued by the County and accepted by the Contractor shall constitute a complete accord and satisfaction as to the Work, Contract Price and Contract Time changed thereby. Contractor shall defend and indemnify the County, as required by section 2.05, if any subcontractor asserts any claim against the County due to a duly issued and accepted Change Order.

Section 17.10. EFFECT ON SURETIES.

All changes authorized by the Contract Documents may be made without notice to or consent of the sureties on the performance and payment bonds and shall not reduce their liability on the bonds.



The County reserves the right to require additional performance and payment bonds to secure a Change Order. In this event, the Change Order shall be increased by the actual cost of the bond premium for the additional bond amounts, if any, up for a maximum of 1%.

ARTICLE 18.

INSPECTION.

Section 18.01. ACCESS FOR INSPECTION.

The Contract Administrator, the Project Architect, the County Inspector(s), and other designated employees or agents of the County, and inspectors of all agencies of jurisdiction over the Project or funds used for the Project shall at all times have access for the purpose of observation to all parts of the Work and to all shops wherein the Work is in preparation. The Contractor shall cooperate and furnish such facilities and assistance as needed for the Inspector(s).

Sections 18.02. NOTICE OF READINESS FOR INSPECTION.

Where the Contract Documents, instructions by the Contract Administrator, laws, ordinances, or any public authority having jurisdiction requires work to be inspected, tested or approved before any portion of the Work proceeds, such work shall not proceed, nor shall it be covered up without inspection.

The Contractor shall give notice to the Contract Administrator at least two (2) days in advance of the readiness for any Contract compliance inspection by the County Inspector. The Contractor shall give notice as required by all other inspection agencies of jurisdiction for Code and regulation compliance inspection. In all cases, the Contractor shall schedule inspection so as not to delay the Work.

Section 18.03. CONTRACT COMPLIANCE INSPECTIONS.

All work done and all materials furnished shall be subject to the inspection and approval of the Contract Administrator for compliance with the Contract Documents, either acting personally or through the County Inspector(s).

Any work covered without required inspection, or not in compliance with the Contract Documents or instructions to the Contract Administrator, shall, upon the instruction of the Contract Administrator, be uncovered for inspection and properly restored after inspection and approval, at no cost to the County.

Section 18.04. INSPECTION OF COMPLETED WORK.

Should the Contract Administrator determine that it is necessary or advisable to make an inspection of Work already completed and inspected at any time before final inspection and acceptance of the Project, by removing or exposing the Work, Contractor shall, upon instruction of the Contract Administrator, promptly furnish all necessary facilities, labor and materials to do so. If such work is found to be defective in any aspect, the Contractor shall bear all expenses of such examination and satisfactory reconstruction. If, however, such work is found to meet the requirements of the Contract Documents, the additional cost of labor and materials necessarily involved in the examination and replacement shall be allowed the Contractor, and a Change Order shall be issued.



This Section shall not apply in the case of Work covered without required inspection, which is governed by Sections 18.02 and 18.03.

Section 18.05. AUTHORITY OF COUNTY; STOP WORK NOTICES.

The Contract Administrator and the County Inspector shall have the authority to order the Work stopped if either determines that the Work is proceeding in violation of the Contract Documents or any orders issued by the Contract Administrator. Such order shall be effective only upon the posting of a stop work notice upon the Work or portions of the Work in question.

Upon issuing a stop work notice, the County Inspector shall immediately notify the Contract Administrator, who shall inspect the Work in question and determine whether it does or does not comply with Contract Documents. The decision of the Contract Administrator shall be final. The Contractor shall thereafter comply with the instructions of the Contract Administrator regarding corrections needed to cure the defect. The stopped Work shall be resumed only when such instructions are fulfilled, and a resume work notice is issued by the Contract Administrator. The Contractor shall not be entitled to an extension in time in the event of such suspension of Work, except as authorized in Section 3.14 hereof.

Section 18.06. EFFECTS OF INSPECTIONS.

Neither the final inspection and payment, nor any interim inspection or progress payment shall relieve the Contractor of any obligation to fully perform the Agreement for Construction as required by the Contract Documents and all applicable laws and regulations.

Any work, materials, or equipment not meeting the requirements and intent of the Contract Documents and all applicable laws and regulations may be rejected, and suitable work or materials shall be made good, notwithstanding the fact that such work or materials may previously have been inspected and/or payment therefore may have been made.

Section 18.07. AUTHORITY OF CONTRACT ADMINISTRATOR.

The Contract Administrator shall decide all questions which may arise as to the quality or acceptability of materials and/or equipment furnished or work performed, and as to the interpretation of Contract Documents and Specifications; all questions as to the acceptable performance of the Contract; and all questions as to compensation.

Section 18.08. AUTHORITY OF COUNTY INSPECTOR(S).

The designated County Inspector is a representative of the Contract Administrator for purposes of inspection of the work for compliance with the Contract Documents and monitoring the Contractor's performance. He is authorized to order a cessation of non-complying Work pursuant to Section 18.05, and to certify the field copies of the Contractor's requests for progress payments. He conducts meetings as required by the Technical Specifications and generally monitors the contractor's performance for the Contract Administrator.



If a person or firm other than the Construction Manager is engaged as County Inspector, the Inspector is not authorized to bind the County in discussions with the Contractor, nor to issue Clarifications, Field Orders, Work Authorizations, or Change Orders.

No interpretations of the Contract Documents made by the Inspector are binding on the County unless the Contract Administrator adopts such interpretation by a written clarification.

The Contractor shall not attempt to influence the Inspector in the performance of his duties, nor request him to exceed his authority. The County shall honor no request by the Contractor that is based on any action of the Inspector beyond the scope of the Inspector's authority as specified in this Section.

Section 18.09. BUILDING INSPECTIONS AND CODES.

The Contractor shall provide access to inspectors from all agencies having jurisdiction over the Project.

Such inspectors are independent of the Contract Administrator and the County Inspector(s), and approval by either shall not constitute approval by the other.

The Contractor shall obey all orders of the inspectors with jurisdiction, and if such inspector reports a violation of any Code within his jurisdiction, the Contractor immediately shall notify the Contract Administrator.

The Contractor is responsible to comply with all applicable Codes in the construction of the Work.



ARTICLE 19.

PUBLIC UTILITIES.

Section 19.01. UTILITIES USED DURING CONSTRUCTION.

Unless otherwise specified in the Contract Documents, the Contractor shall provide and pay for all necessary water, gas, and electricity required for himself, and all trades employed in the performance of the Agreement for Construction.

The Contractor shall send all required notices, make all necessary arrangements, and perform all other services required in the care and maintenance of such utilities, and assume all financial responsibility concerning the care and maintenance of said utilities.

All temporary connections to such utilities shall be maintained in such manner as not to interfere with the continuing use of such utilities by the County during the entire progress of the Work.

The enclosing of such public utility equipment shall be done by the Contractor consistent with the requirements of the utility. Upon completion of the Work, the Contractor shall remove all enclosures and fill-in and leave in a finished condition all openings for such utilities.

Section 19.02. LIGHTING.

Contractor shall furnish, wire for, install and maintain temporary electric light whenever it is necessary to provide illumination for the proper performance and inspection of the Work, unless otherwise specified. The lighting shall provide sufficient illumination and shall be so placed and distributed that the Contract Documents can be easily read in every place where the Work is being performed. This temporary lighting equipment may be moved about, but shall be maintained throughout the Work and available for the use of the Contract Administrator or County Inspector(s) whenever required for inspection.

Section 19.03. PERMANENT UTILITIES; INSTALLATION.

The Contractor shall install all permanent utilities called for by the Construction Documents strictly in compliance with all laws, regulations and requirements of the particular utility company or governmental agency providing the utility.

Section 19.04. TOILET FACILITIES FOR WORKERS.

The Contractor shall provide and maintain for the duration of the Work temporary toilet facilities as required by the Yolo County Health Department, which shall be weather-tight structures with raised floors.

The Contractor shall service such facilities daily and shall pump such facilities as required, to maintain them in a clean and sanitary condition.

Section 19.05. DISRUPTION OF UTILITY SERVICE.

The Contractor shall secure the advance approval of the Contract Administrator regarding scheduling of any disruption of utility service to other structures necessitated by the Work.



The Contractor is advised that unscheduled disruptions of electrical service to County buildings may seriously damage computer and word-processing equipment and/or software, and other equipment and/or material in use in such building, and the Contractor will be liable for all resulting repair and re-programming costs if occasioned by an unscheduled disruption caused by Contractor.

Section 19.06. UTILITIES FOR COUNTY PERSONNEL.

If the Contract Documents call for the Contractor to provide temporary on-site office trailers for County personnel involved in the Project, the Contractor shall provide utility services for such trailers pursuant to this Article.

REMAINDER OF PAGE INTENTIONALLY LEFT BLANK

////////////////////////////////////



ARTICLE 20.

PERMITS, LICENSES, ORDINANCES AND REGULATIONS.

Section 20.01. COMPLIANCE WITH CONSTRUCTION REGULATIONS.

The Contractor shall conduct the Work so that all laws, regulations, and ordinances for the protection of the public and the workers shall be obeyed fully both by the Contractor and by all subcontractors on the site.

The Contractor shall obtain and keep current all licenses or permits required by the State Contractor's Licensing Act and/or other licenses required to authorize him to perform the Work and shall require all subcontractors to comply with this section.

Section 20.02. PERMITS; FEES.

Unless otherwise specified by the Contract Documents or ordered by the Contract Administrator, the Contractor shall obtain all permits, licenses and/or entitlements that are required for the performance of the Work by all laws, ordinances, rules, and regulations or orders of any officer and/or body with jurisdiction, shall give all notices necessary in connection therewith, and shall pay all fees required relating thereto and all costs or expenses incurred on account thereof.

Section 20.03. COMPLIANCE WITH LAWS AND REGULATIONS.

The Contractor shall keep himself fully informed of and shall observe and comply with, and shall cause all subcontractors and all employees to observe and comply with all Federal and State laws, and County or Municipal Ordinances, regulations, orders or decrees which in any manner affect those engaged or employed on the Work, or the materials used in the Work, or in any way affect the conduct of the Work. The Contractor shall ensure that the Work is constructed and completed in compliance with all applicable laws and regulations.

Section 20.04. VIOLATION OF LAWS AND REGULATIONS; INDEMNITY.

The Contractor shall save harmless, defend, and indemnify the County and all of its officers, agents, and employees against any liability or claim arising from or based upon the violation of any law, ordinance, regulation, order or decree, whether by himself, his agents, employees, or his subcontractors or their agents or employees.

Section 20.05. SPECIFIC STATE LAWS AND REGULATIONS.

In addition to the general requirements set forth above, the Contractor's attention is directed to and Contractor shall be responsible for performing and completing the Work in compliance with all laws of the State of California governing the construction of buildings in general as well as those governing construction of public buildings, including, without limitation, the following:

- A. The California Health & Safety Code and all applicable Administrative Code regulations adopted pursuant thereto.



- B. All laws governing the employment of labor, qualifications for employment of aliens, payment of employees, convict-made materials, domestic and foreign materials, and accident prevention.
- C. Title XIX of the California Administrative Code entitled, "Public Safety", Chapter 1, State Fire Marshal, Sub-chapter 12, General Fire and Panic Safety".
- D. General Industrial Safety Orders, including but not limited to the provisions of Title VIII of the California Administrative Code relating to safe and proper use, construction, disposal, etc. or materials, machinery, and building appurtenances as therein set forth.
- E. All rules and regulations of the State Fire Marshall; the safety orders of the Division of Industrial Safety; and Department of Industrial Relations regulations.

All of the above laws and regulations are expressly incorporated in the Agreement for Construction and are as much a part of the Contract Documents as if they were incorporated in their entirety in these General Conditions.

The Contractor shall not interpret the enumeration set forth above as being a complete listing of all applicable laws. It is also the Contractor's responsibility to inform himself regarding the requirements of all applicable laws regarding the performance of construction contracts for California counties and to obey them, and the Contractor agrees by execution of the Agreement for Construction to do so at his sole cost, expense and risk. (See also Section 14.07 regarding Cal OSHA and Section 20.08 regarding hazardous materials).

Section 20.06. COMPLIANCE WITH CONDITIONS OF PERMITS.

The Contractor shall conduct the Work in conformity with the conditions imposed on all permits or other entitlements which address the performance of the Work by the Contractor, whether or not such permits or entitlements are incorporated in the contract Documents.

Such permits may include, but are not limited to, measures required during the construction of the Work and incorporated in the Project to avoid or mitigate the environmental effects of the Project, pursuant to the California Environmental Quality Act, and conditions imposed on use permits issued by any agency with jurisdiction.

It shall be the Contractor's responsibility at all stages, from bidding through final completion, to inform himself of the requirements of any such permits. Copies are available from the Contract Administrator.

The Contractor's attention is directed to the Supplementary Conditions and Technical Specifications setting forth additional requirements, if any, regarding this subject.

Section 20.07. COMPLIANCE WITH CONDITIONS OF GRANTS.

The Contractor shall conform to all requirements of Federal and/or State authorities that have provided grant funding for the Project. Specific requirements are specified in the Supplementary Conditions and Contract Documents. Without limitation thereof, Contractor shall keep financial, wage and hours, equal employment opportunity and other records required by any such grant and shall allow access to the Site by inspectors from such agencies.



The Contractor shall cooperate fully with and assist the County in its efforts to comply with all conditions imposed on such grant funding.

Section 20.08. HARMONIZATION WITH CONTRACT DOCUMENTS.

The Contract Documents are intended to be coordinated to described and provide for the complete Project in a manner that complies with all applicable laws and regulations.

In the event of a conflict between the Contract Documents and the applicable laws and regulations, the applicable laws and regulations shall govern; provided, however, that in the event of conflict involving quantity or quality, the greater quantity and the higher quality shall be furnished. All other conflicts shall be handled in the manner described in Section 4.02 of these General Conditions.

Section 20.09. COMPLIANCE WITH HAZARDOUS MATERIALS REPORTING AND USE REQUIREMENTS; CLEAN-UP; INDEMNITY; WITHHOLD.

- A. **Reporting and Use:** The Contractor shall file all reports required by Federal and/or State agencies regarding the presence on the Site and/or use of toxic or any hazardous material and shall store and/or use such materials in strict conformity with all applicable laws and regulations.
- B. **Clean-Up:** The Contractor shall clean-up any toxic or hazardous spill or pollution caused by the Contractor and/or any subcontractor, material man or carrier occurring on the Site, and shall remove all polluted water, dirt or materials to an approved disposal site, as required by the Federal and/or State agencies with jurisdiction or, if none, by the County Health Department, all without cost to the County.
- C. **Indemnity:** The Contractor shall save harmless, indemnify and reimburse the County for all costs for defense of any County liability, cost, claim or damages resulting from the Contractor's failure to perform Paragraphs "A" and/or "B" of this Section, and/or a toxic or hazardous spill within Paragraph "B" of this Section.
- D. **Withhold:** In addition to all withholds or retentions authorized by the Agreement for Construction, the County shall retain sums sufficient to offset the County's costs resulting from Contractor's failure, refusal or neglect to conform to all requirements of this Section.



ARTICLE 21.

PRESERVATION AND CLEANING.

Section 21.01. PROTECTION OF WORK.

The Contractor shall protect and preserve the Work from all damage or accident, and shall at its cost provide any temporary roofs, window and door coverings, enclosures, boxing, or other construction as required for this purpose.

Section 21.02. PERIODIC CLEANING OF PROJECT.

The Contractor shall properly clean the Site and the Work as it progresses, and from time to time shall remove all dirt, debris, waste, rubbish, and implements of service from the Project and the Site. Debris, waste, or unused construction materials shall not be left under, in, or about the Project, nor allowed to accumulate in the Project or the Site. The Technical Specifications specify additional requirements regarding this subject.

The Contractor, at its sole cost, shall contract with a disposal company to remove all such rubbish, and shall have the containers therefore emptied at frequent enough intervals so that waste does not overflow the containers.

Section 21.03. FINAL CLEANING OF PROJECT.

Prior to the request for Final Inspection, the Contractor shall thoroughly clean the interior and exterior of the Work, and do all things required by the Technical Specifications regarding final cleaning.

Final cleaning shall not be accepted unless the Project is in all respects ready to occupy without further cleaning by County forces.



ARTICLE 22.

OCCUPANCY BY COUNTY.

Section 22.01. USE OF COMPLETED WORK.

Whenever, in the opinion of the County, the Work or any part thereof is in a condition suitable for use, and the best interests of the County require such use, the County may take possession of, connect to, and open for public or County use, the Work or any part thereof, subject to this Article.

Section 22.02. REPAIRS OR RENEWALS IN THE WORK.

Prior to the date of final acceptance of the Work by the County, all necessary repairs or renewals of the portion of the Work occupied pursuant to Section 22.01 hereinabove (or part thereof) shall be made at the Contractor's expense if necessary due to defective material and/or workmanship, or to the operations of the Contractor, ordinary wear and tear excepted.

Section 22.03. EFFECT OF OCCUPANCY.

The occupancy by the County of the Work or any part thereof as authorized by this Article shall in no case be construed as constituting acceptance by the County of the Work or any part thereof. Such use shall neither relieve the Contractor of any of his responsibilities under the Contract Documents, nor act as a waiver by the County of any of the terms or conditions of the Agreement for Construction. Notwithstanding occupancy by the County pursuant to this Article, the warranty periods on all products and the Contractor's basic warranty pursuant to Article 26 shall not commence, and the term thereof shall not be diminished, as a result of County occupancy. The warranty periods commence only upon recordation of a Notice of Cessation of Work or a Notice of Completion.

Section 22.04. COORDINATION WITH OTHER ACTIVITIES.

In the event that the Project, or any portion of the Site, is occupied by the County during the Work, it shall be the responsibility of the Contractor to conduct his operations so as not to unreasonably interfere with the use of the occupied portions by the County.

The Contractor shall submit periodic schedules to the Contract Administrator proposing the times, areas, and types of work to be done within such areas. The Contract Administrator shall approve, conditionally approve, or reject such schedule, and the Contractor shall comply with the Contract Administrator's instruction.

In the event that the Work produces conditions rendering uninhabitable the portions of the Project, the Site, or other areas occupied by the County, either because of noise, dust, vibration, smoke, fumes, or for any other cause, the Contract Administrator may order the Work ceased, or modifications to the schedule, and the Contractor shall comply at its sole cost and expense.

Section 22.05. PRICE OR TIME ADJUSTMENTS.

In the event the County exercises its right to take early occupancy pursuant to this Article, and provided that the Contract Documents at the time of bidding did not specifically indicate the County's



intention to do so, the Contractor may request an adjustment to the Contract Price and/or Time, for extra costs and/or time directly caused by the early occupancy. Article 17 shall apply to any request by the Contractor for a Contract Price adjustment, and Article 3 to a Contract Time adjustment, resulting from the County's occupancy pursuant to this Article.

THE REMAINDER OF PAGE INTENTIONALLY LEFT BLANK

////////////////////////////////////



ARTICLE 23.

PROGRESS PAYMENTS.

Section 23.01. SUBMISSION OF CLAIMS.

On or before the seventh (7th) day of each month, the Contractor shall prepare and forward to the Contract Administrator a statement in writing, on forms provided by the County, detailing the following work done during the preceding month:

- A. The units or work completed during the preceding month, with reference to the Progress and Value Schedules approved pursuant to Article 3, or approved modifications thereto, and the date of inspection and approval thereof.
- B. The portion of the progress claim attributable to such units of work.
- C. All acceptable materials furnished and delivered to and stored on the Site or other approved location for use in the performance of the Work, but not yet incorporated in the Work.
- D. The value of such materials, with reference to the Schedules of Value provided pursuant to Article 3 hereof.
- E. The date of inspection and approval by the County of any such materials and labor.

If the Contract Documents require the sampling and testing of any such materials or labor, the claim shall indicate whether such sampling and testing has been approved and, if so, the date thereof.

As part of such claim for payment, the Contractor shall agree that, upon payment of such claim (or part thereof), the Contractor will indemnify, defend and hold harmless the County, its officers, agents and employees from and against any and all claims for damages, costs, compensation or any other recovery, including but not limited to claims of the Contractor, subcontractors, suppliers, laborers and workers, based upon the portion of the Work for which payment is claimed (or such part thereof for which payment is made). As part of such claim for payment, Contractor shall also provide proof that all subcontractors, suppliers, etc. have been paid and have provided releases for all portions of the Work for which the Contractor has previously been paid. Such claims shall be executed by the Contractor under penalty of perjury.

Each payment request shall be reviewed by the Contract Administrator as soon as practical after receipt for the purpose of determining that the payment request is a proper payment request. Any payment request determined not to be a proper payment request suitable for payment shall be returned to the contractor as soon as practicable, but not later than seven days, after receipt. A request returned pursuant to this paragraph shall be accompanied by a document setting forth in writing the reasons why the payment request is not proper.

Within seven (7) days of receipt of a fully completed claim form, the Contract Administrator shall verify such claim and shall take such steps as are necessary to investigate the accuracy of any statements made by the Contractor. Contractor shall provide such other and further documentation as ordered by the



Contract Administrator to enable verification of a claim for a progress payment and the time until such additional documentation is delivered shall extend the time for processing the claim.

The Contract Administrator shall verify the claims for progress payments by use of the Progress and Value schedules approved pursuant to Article 3 hereinabove, or subsequently approved modifications thereto.

Section 23.02. PAYMENT; WITHHOLDS.

Upon approval of a claim for progress payment by the Contract Administrator, such claim shall be paid; provided, however, that the following amounts shall be withheld as security:

- A. No greater than Ten (10%) percent of the value of the Work done.
- B. Ten (10%) percent of the value of the acceptable materials delivered to and accepted by the County, but not yet incorporated in the Work.

Within the time specified in the Contract Documents, the County shall pay to the Contractor, while the Contractor is carrying on the Work, the balance of any progress payment not withheld as set forth above, after deducting therefrom all previous payments and all sums to be retained under the provisions of law or of the Contract Documents.

No payment by the County shall be construed to be an approval by the County of any defective work or improper materials, nor as an acceptance as completed of any portion of the Work.

If the County fails to make any progress payment within 30 days after receipt of an undisputed and properly submitted payment request, the County shall pay interest to the Contractor equivalent to the legal rate set forth in subdivision (a) of Section 685.010 of the Code of Civil Procedure.

Section 23.03. POSTING SECURITIES IN LIEU OF WITHHOLDS.

Pursuant to Public Contract Code Section 22300, at the request and expense of the Contractor, securities equivalent to the amount withheld shall be deposited with the County, or with a state or federally chartered bank as the escrow agent, who shall pay such monies to the Contractor upon satisfactory completion of the Contract.

Securities eligible for investment under this section shall include those listed in Government Code 16430 or bank or savings and loan certificates of deposit.

The Contractor shall be the beneficial owner of any securities substituted for monies withheld and shall receive any interest hereon.

The escrow agent shall be a trustee of the County.



Section 23.04. RETAINING ADDITIONAL AMOUNTS; GROUNDS.

In addition to the amounts which the County withholds as provided in Section 23.02, the County shall retain a sufficient amount of any payment otherwise due to the Contractor as in the sole discretion of the Contract Administrator may be necessary to protect the County in the event of the following:

- A. The receipt of Stop Notices and Claims against the Contractor or any subcontractor for labor or materials furnished on the Project;
- B. For the cost to correct defective work not remedied, including failure to periodically clean the Site and Work as specified in Section 21.02.
- C. For failure of the Contractor to make progress payments to any of its subcontractors;
- D. For the occurrence of reasonable doubt that the Project can be completed for the balance of the Contract Price, as reflected in the approved Schedule of Values, or within the Contract Time, as shown on the approved Progress Schedule;
- E. For the refusal of the Contractor to commit sufficient resources so that the Work proceeds in accordance with the approved Progress Schedule. Section 3.11 regarding Liquidated Damages shall apply in such event;
- F. For failure of the Contractor to comply with any lawful or proper direction concerning the work given by any County representative authorized to have given such instruction;
- G. For claims and/or penalties which State or Federal law assesses against the Contractor for violation of such law, including prevailing wage claims;
- H. For any claim or penalty asserted against the County by virtue of the Contractor's failure to comply with the provisions of all governing laws, ordinances, regulations, rules and orders;
- I. For any reason specified elsewhere in the Contract Documents as grounds for retention.

In order to adequately to protect the County, the basic standard to determine the amount of retention pursuant to this section shall be ONE-HUNDRED-TWENTY-FIVE (125%) PERCENT of the amounts claimed or the value of the Work not done or defectively done, plus interest and litigation costs; provided, however, that County retains the authority to retain greater sums should such sums be necessary in the County's discretion adequately to protect it.

In the event the progress of the Work does not meet the approved Progress Schedule, the County may retain the amounts specified in Section 3.11 and Section 2 of the Agreement for Construction for each day the Work is behind schedule.

The County retains the right to make, or not to make, any partial progress payment involving sums not in dispute, or to retain the total progress payment pending resolution of any such dispute.



Section 23.05. DISBURSEMENT OF RETAINED AMOUNTS.

The County, in its sole discretion, may apply any such retained amount or amounts to the payment of any such claims resulting in a retention. Any payment, so made by the County, shall be considered as a payment made under this Contract by the County to the Contractor. The County shall not be liable to the Contractor for any such payments made in good faith. Such payments may be made without a prior judicial determination of the claim or claims. The County shall render to the Contractor a proper accounting of any such funds dispersed on behalf of the Contractor. The County reserves the right to utilize warrants issued to the Contractor and Claimant as joint payees for this purpose.

Prior to applying such amounts as stated hereinabove, County shall afford the Contractor an opportunity to present good cause, if any he has, why the claim or claims in issue are not valid or just claims against the Contractor. The County then reserves the right to take such further steps as are appropriate, in its sole discretion, including, but not limited to, seeking a judicial resolution of the controversy.

Section 23.06. CORRECTION OF STATEMENT AND WITHHOLDING OF PAYMENT.

No inaccuracy or error in any claim provided by the Contractor shall operate to release the Contractor or any surety from the error, or from damages arising from such error, or from any obligation imposed by the Contract Documents. The County shall retain the right subsequently to correct any error made in any previously approved claim for the progress payment, or progress payment issued, by later adjustments to subsequent progress payments.

Section 23.07. EFFECT OF PROGRESS PAYMENTS.

Neither the payment, the withholding, nor the retention of all or any portion of any progress payment claimed to be due and owing to the contractor shall operate in any way to relieve the Contractor from his obligations under the Agreement for Construction. The Contractor shall continue diligently to prosecute the Work without reference to the payment, withhold or retention, of any progress payment. The payment withhold or retention of any progress payment shall not be grounds for an adjustment to the Contract Time or Contract Price. By making progress payments, the County waives no right nor releases any obligation of the Contractor to the County.



ARTICLE 24.

FINAL INSPECTION.

Section 24.01. NOTICE OF FINAL INSPECTION.

When the Work is completed, the Contractor shall request a final inspection. Within ten (10) days of the receipt of such request, the Contract Administrator shall make a final inspection. The Contractor or his representatives may be present at the final inspection. The purpose of such final inspection shall be to determine whether the Work has been fully completed in accordance with the Contract Documents, including all modifications previously issued.

Section 24.02. PUNCH LIST.

The Contract Administrator shall notify the Contractor in writing of any deficiencies to be remedied prior to final acceptance, by preparing a written list of deficiencies, known in the industry as a "punch list".

The Contractor shall remedy all items shown on the punch list prior to final acceptance by the Contract Administrator.

The Contract Administrator is not authorized to amend the Contract by use of the punch list; it is provided solely for the benefit of the Contractor to enable him to determine whether items must be corrected before final acceptance will be recommended by the Contract Administrator. The County reserves the right to require compliance with the Contract Documents, notwithstanding the issuance of a punch list or the completion by the Contractor of all items on the punch list.

In the event that the Work still does not comply with the Contract Documents, the County reserves the right to issue such further punch lists as may be required, or to deduct from the final payment the cost of correction of any Work not completed in accordance with the Contract Documents without the issuance of further punch lists.

Section 24.03. ADDITIONAL SUBMITTALS.

After completion of work on punch list items, and before the Contractor's Request for Final Payment, the Contractor shall submit the following items:

- A. A complete and accurate accounting, showing the total amounts claimed by the Contractor, all subcontractors and all suppliers due for final payment of the Project. The accounting shall identify first-tier subcontractors (those with a contract directly with the contractor) separately from all other claimants and shall include all subcontractors listed by the Contractor pursuant to Article 11. This accounting shall be submitted under penalty of perjury.
- B. A complete and accurate set of Record (as-built) Drawings prepared by the Contractor pursuant to Section 4.05 and the Technical Specifications.
- C. The Contractor's guarantee required by Article 26 hereof, and all other guarantees and warranties required by the Contract Documents.



- D. The Contract bond securing the Contractor's guarantee pursuant to Article 26 hereof.
- E. Proof acceptable to County of proper release from all claims regarding patents and/or copyrights pursuant to Section 6.09 hereof.
- F. All operating manuals required by the Technical Specifications for all mechanical and electrical installations.
- G. All other submittals required by the Contract Documents prior to final payment.

Section 24.04. SYSTEMS DEMONSTRATION.

Before submitting a Request for Final Payment, Contractor shall demonstrate the operation of all systems in the Work to such persons as directed by the Contract Administrator, and shall instruct County personnel in the operation, adjustment, and maintenance of all equipment and systems.

REMAINDER OF PAGE INTENTIONALLY LEFT BLANK
////////////////////////////////////



ARTICLE 25.

ACCEPTANCE AND FINAL PAYMENT; ADMINISTRATION OF THE WITHHOLD ACCOUNT.

Section 25.01. CONTRACTOR'S REQUEST FOR FINAL PAYMENTS AND CHANGE ORDERS.

When the Work is fully (100%) complete and all items on the punch list have been satisfied, or the Contractor contends that such items are not required by the Contract Documents, the Contractor shall submit Requests for Final Progress Payment and Final Payment.

The request for Final Progress Payment shall include the total amount the Contractor contends is due on the Contract Price less the amounts to be withheld for Final Payment. The amounts to be withheld for Final Payment shall include no less than One-Hundred Twenty-Five Percent (125%) of the total of all claims identified by the Contractor in the accounting submitted pursuant to Section 24.03-A, plus One-Hundred-Twenty-Five Percent (125%) of all unpaid claims against the Project by the County or any other claimant, which claims authorize a County withhold and/or retention pursuant to the Contract Documents, State or Federal law.

With the requests for Final Progress Payment, the Contractor shall submit its request for a final Contract Price Change Order with all information required by Article 17, and/or Contract Time Change Order, with all information required by Article 3, if the Contractor requests an adjustment in the Contract Price and/or Contract Time then in effect.

Section 25.02. CONTRACTOR ADMINISTRATOR'S ESTIMATE.

Upon receipt of all required submittals and the Contractor's Requests for Final Payments, the Contract Administrator shall conduct a final inspection to identify any deviations from the Contract Documents in the Work, and estimate the cost of corrections of such deviations.

After Final Inspection, the Contract Administrator shall prepare an estimate of the final sum due the Contractor. Said estimate shall take into account the Contract Price, as adjusted by any Change Orders; amounts previously paid; the Final Progress Payment; and sums to be withheld and/or retained for claims against the Project for incomplete work, liquidated damages, and for any other cause under the Contract. The Contract Administrator shall deliver a copy of this transmittal to the Contractor.

The Contract Administrator's estimate shall address whether the completion date for purposes of calculating liquidated damages should relate back to the date of the Contractor's Request for Final Payment, pursuant to Section 3.06.

Section 25.03. PROTEST TO PROCUREMENT MANAGER

If the Contractor contests the estimate of sums due prepared by the Contract Administrator, the Contractor shall, within five (5) days following delivery of the Contract Administrators' final inspection report, file his protest in writing with the Procurement Manager, setting forth in detail all grounds alleged to justify adjustment to the Contract Administrator's final estimate. Failure to file such protest shall constitute a waiver of the right to contest or otherwise challenge the Contract Administrator's final inspection report and estimate, and acceptance of the rest by Contractor.



Section 25.04. RESOLUTION AUTHORIZING ACCEPTANCE OF CONTRACT AND RECORDATION OF NOTICE OF COMPLETION.

Acceptance of the Work by the Board of Supervisors and the recordation of a Notice of Completion shall be in the manner prescribed by law, provided that the County is of the opinion that the Work is fully and satisfactorily completed and the provisions of the Contract Documents fully and satisfactorily performed in all respects. The acceptance of the Work by the County will only be made by resolution of the Board of Supervisors in a regular session. The Notice of Completion shall specify the date of the Resolution of Acceptance as the completion date and shall be recorded in the manner provided by law.

The County reserves all rights provided by law and/or the Contract Documents if the Work is not fully satisfactory and complete in all respects.

The resolution shall specify the final Contract Price and Time, with deductions and/or offsets for liquidated damages, the cost of correction of defective work or workmanship, inadequate clean-up, non-compliance with the Contract Documents, or statutory fines, forfeitures or penalties.

Section 25.05. DETERMINATION OF FINAL PROGRESS PAYMENT AND WITHHOLD AMOUNT.

After the Board of Supervisors has approved a Final Contract Price and Time, the Contract Administrator shall adjust the withhold Amount, as follows:

- A. At no time shall the withhold amount be less than five (5%) percent of the Final Contract Price, or One-Hundred-twenty-Five (125%) percent of the total of all claims against the Project from all sources, including the County, whichever is the greater amount.
- B. The Contract Administrator is authorized to withhold additional sums necessary to protect the County in his sole discretion, if claims, including State or Federal prevailing wage claims, and/or stop notices are filed, or to secure the County's own claims.
- C. The Contract Administrator is authorized to process payment(s) to the Contractor at such frequency as the Contract Administrator shall determine, when the Contractor has provided acceptable submittals with its request(s) for release of withheld amounts, as specified in Section 25.06.

Section 25.06. SUBMITTALS FOR RELEASE OF WITHHELD AMOUNTS.

With its request for release of amounts withheld and/or retained by the County, the Contractor shall submit the following:

- A. Receipts and releases on forms standard in the industry and approved by the County, from all first-tier subcontractors, releasing the County from all further claim or liability.
- B. Receipts and releases, including Stop Notice releases if stop notices have been filed, from any persons or firms claiming against the Project; or fully executed agreements by such claimants specifying a settlement of their claims.



- C. Releases and authorizations to pay from any State or Federal agency claiming against the Project, including prevailing wage claims.
- D. Waiver of all claims by the Contractor against the County except those which the Contractor expressly specifies therein as being outstanding and not included in the waiver.

The maximum amount the Contractor may request to be released shall not exceed the amount specified in Section 25.05-A.

Section 25.07. ADMINISTRATION OF WITHHOLD ACCOUNT.

The County reserves all rights regarding its administration of the withhold fund, with or without filed Stop Notices, including all judicial remedies provided by law.

In its sole discretion, the County may contact such claimants, or any of them, and reach independent settlement of their claims, through use of warrants jointly payable to claimants or otherwise.

In addition, the County is authorized to retain sums as needed, in its sole discretion, to secure its own claims.

Section 25.08. PAYMENT OF WITHHELD AMOUNTS.

On the thirty-fifth (35th) calendar day following recordation of a Notice of Completion, the undisputed balance owing in the withhold account shall be due and payable to Contractor.

The "undisputed balance owing" shall be the difference between the final Contract Price fixed by the Board of Supervisors' Resolution of Acceptance less the following amounts:

- A. All payments made to date;
- B. One-Hundred-Twenty-Five (125%) percent of the total amounts claimed in unresolved stop notices on file with the County or wage claims and related penalties in the jurisdiction of any State or Federal wage compliance office;
- C. The total of any claims by the County for defective work, and/or liquidated damages.

The balance owing shall be "due and payable" upon presentation by the Contractor of releases executed by the Contractor, releasing the County of Yolo from all claims arising by virtue of the Agreement for Construction related to the amounts released from the withhold.

Payment of undisputed contract amounts is contingent upon the Contractor furnishing the County with a release of all claims against the public entity arising by virtue of the Agreement for Construction. The Contractor shall specifically identify in the release any disputed claim, including the amount thereof, which is excluded from the release. Any claim not so specified within the release shall be forever released, discharged, and waived. If the Contractor disputes the amount owing by the County, the final balance in the Withhold Account shall become due and payable only upon execution by the Contractor and the County of an accord and satisfaction agreement acceptable to both, by which both release the other from all claims.



If the Contractor accepts the final balance in the Withhold Account as the total due and payable by the County, and provides a written final release, the accord and satisfaction agreement shall not be required.

Nothing in this Article shall be construed as requiring the Contractor to waive any claim against the County in violation of Public Contracts Code Section 7100, nor as constituting a waiver by the County of any claim or legal right against the Contractor.

Section 25.09. NON-WAIVER.

Neither acceptance of nor payment for the Work or any part thereof, nor any extension of time, nor any possession taken by the County shall operate as a waiver of any of the provisions of the Agreement for Construction, nor shall a waiver of any breach of this Agreement be held to be a waiver of any other or subsequent breach. In addition, adoption of a Resolution of Acceptance and recordation of a Notice of Completion shall not be deemed an acceptance of latent defects, shall not constitute a waiver of any of the provisions of the Agreement, and shall not relieve the Contractor of its obligation to complete the work as specified in the Contract Documents and in compliance with all applicable laws and regulations.

Section 25.10. WORK AFTER NOTICE OF COMPLETION.

Contractor shall do no work after recordation of a Notice of Completion, save only work required by the warranties and guarantees provided under the Agreement for Construction.

Any work done after recordation of a Notice of Completion shall be conclusively presumed to be in furtherance of the Contractor's obligations on such warranties and guarantees for all purposes.

Section 25.11. STOP NOTICES; WHERE TO FILE; ENFORCEMENT.

All persons are advised hereby that all Preliminary Notices and Stop Notices shall be filed at the following address:

County of Yolo
Director of General Services
Yolo County General Services Department 120 West Main Street, Suite G
Woodland, CA 95695

The envelopes and the Notice shall clearly designate the name of the Project.

The Contractor shall cause the provisions of this Section to be inserted in all subcontracts and material contracts executed by the Contractor and notice of this provision shall be given to all persons furnishing materials for the Work.

All Stop Notice claimants are referred to Civil Code Section 3103 for the required contents of a Stop Notice, and Sections 3179 and following regarding enforcement/release of Stop Notice.



ARTICLE 26.

GUARANTEES AND WARRANTIES.

Section 26.01. GUARANTEE REQUIRED.

In addition to any guarantees required elsewhere by the Contract Documents, the Contractor shall guarantee the Work for a period of one (1) year from and after the recordation of the Notice of Completion, Notice of Cessation or, if neither is recorded, upon actual cessation of the Work. Such guarantee shall be made on the form provided, as set forth in Section 26.02 below.

Such guarantee is in addition to, and not in lieu of, the County's rights to enforce the Agreement for Construction in all respects, and the County's rights on all other guarantees and warranties required by the Technical Specifications.

Section 26.02. FORM OF GUARANTEE.

The guarantee required by this Article shall provide as follows:

The (Contractor) hereby unconditionally guarantees that the Work performed pursuant to the (Name of Project) Agreement for Construction (Yolo County Agreement No.) has been fully performed and completed in accordance with the requirements of the Agreement for Construction therefore and in compliance with all applicable laws and regulations, and further guarantees the Work of the Contract to be and remain free of defects in workmanship and materials for a period of one (1) year from the date of recordation of a Notice of Completion, Notice of Cessation, or actual cessation of work, whichever is longer. The Contractor hereby agrees to repair or replace any and all the Work, together with any adjacent Work which may have been damaged or displaced in so doing, that is not in accordance with the requirements of the Agreement and applicable laws and regulations, or that may be defective in its workmanship or material within the guarantee period specified, without any expense whatsoever to the County of Yolo, ordinary wear and tear excepted. The Contractor has provided contract bonds that will remain in full force and effect during the guarantee period.

The Contractor further agrees that within ten (10) calendar days after being notified in writing by the County of Yolo of any Work not in accordance with the foregoing requirements he will commence and prosecute with due diligence all Work necessary to fulfill the terms of this guarantee, and to complete the Work within a reasonable period of time. In the event he fails to so comply, he does hereby authorize the County of Yolo to proceed to have such Work done at the Contractor's expense and he will pay the cost thereof upon demand. The County shall be entitled to all costs, including reasonable attorney fees, necessarily incurred upon the Contractor's refusal to pay the above costs.

Notwithstanding the foregoing paragraph, in the event of an emergency constituting an immediate hazard to the health or safety of the employees or property of the County of Yolo, the County may undertake, at the Contractor's expense and without prior notice, all Work necessary to correct such hazardous condition when it was caused by the Work and/or the Contractor's not being in accordance with the foregoing requirements, and to charge the same to the Contractor as specified in the preceding paragraph.



This guarantee set forth herein is not intended by the parties, nor shall it be construed, as in any way limiting or reducing the County of Yolo's rights to enforce all terms of the Agreement for Construction referenced hereinabove or the time for enforcement hereof. This guarantee is provided in addition to, and not in lieu of, the County's rights on such Agreement.

This Agreement is in addition to, and not in lieu of, the County's rights on all other guarantees and warrants required by the Contract Documents.

CONTRACTOR' SIGNATURE

(CORPORATE SEAL)

Section 26.03. GUARANTEE CONTRACT BOND.

Prior to Final Payment, the Contractor shall post a surety securing performance of his guarantee, as required by section 2.04 hereof.

Section 26.04. OTHER GUARANTEES.

All other guarantees or warranties required by the Contract Documents shall be subject to approval as to form by the County. At a minimum, such guarantees or warranties shall provide that the guarantor/warrantor shall repair or replace defective materials and/or workmanship, along with adjacent work that may be damaged or displaced in so doing and shall be unconditional. Such guarantees are in addition to, and not in lieu of, the product manufacturers' warranties, expressed or implied, and the Contractor's guarantee required by this Article.

Section 26.05. GUARANTEES NOT WAIVER.

By accepting the guarantees required by the Contract Documents, the County shall not be deemed to have waived any warranty or buyer protection implied, required and/or provided by the law of the State of California, nor to have altered any applicable statute of limitations regarding enforcement of any right of the County created by the Agreement for construction or otherwise. These guarantees and warranties are in addition to, and not in lieu of, such rights.

No disclaimer or limitation of any such right shall be valid unless properly executed by the County.



ARTICLE 27.

COUNTY'S RIGHT TO TERMINATE AGREEMENT.

Section 27.01. GROUNDS FOR TERMINATION.

The County may terminate the Agreement for Construction, pursuant to the provisions of this Article, for the following causes:

- A. The Contractor has been adjudged bankrupt or has made a general assignment for the benefit of creditors, or that a receiver has been appointed on account of the insolvency of the Contractor.
- B. The Contractor or any of his subcontractors violates any of the provisions of the Contract Documents or fails to perform the Work within the Contract Time specified in the Progress Schedule then in effect and approved by the County;
- C. The Contractor or any of his subcontractors fails to make prompt payment to subcontractor or material men for material or for labor.
- D. The Contractor or a subcontractor persistently disregards laws, ordinances, or the instructions of the County.
- E. The Contractor fails to provide and keep in full force and effect all required insurance, and to cause all subcontractors to so comply.
- F. Neglect of the work amounting to material breach of the Agreement for Construction.
- G. Any other material breach by the Contractor.

Section 27.02. PROCEDURE FOR TERMINATION.

Upon the certification of the Contract Administrator that sufficient cause exists to justify the termination of the Agreement for the Construction, the County Administrator may, without prejudice to any other right or remedy of the County, give written notice to Contractor and his surety or sureties of its intention to terminate the Agreement.

Unless within seven (7) days of the giving of such notice, the Contractor shall cease such violation and make satisfactory arrangements for a correction thereof, the Agreement shall, upon the expiration of the said seven (7) days, cease and terminate.

In the event of any such termination, the County shall immediately give written notice thereof to the surety and to the Contractor and the surety shall have the right to take over and perform the Contract; provided, however, that if the surety within fourteen (14) days after service of the notice of termination, does not commence performance of the Contract, the County may take over the Work and prosecute the same to completion by contract or by any other method it may deem available, for the account and at the expense of the Contractor, and the Contractor and his sureties shall be liable to the County for any costs occasioned by the County thereby. In such event, the County may, without liability, take possession of and utilize in



completing the Work, such materials as may be on the Site of the Work and necessary, therefore. In any such case, the Contractor shall not be entitled to receive any further payment until the work is finished.

Section 27.03. RECONSTRUCTION IN EVENT OF LOSS.

In the event of a partial or total destruction of any or all of the work or materials to be provided pursuant to this Agreement, at any time prior to the final completion of the Project and the final acceptance of the Work by the County, the Contractor promptly shall reconstruct, repair, replace or restore, all work or materials so destroyed at no cost to the County.

Nothing herein provided shall in any way excuse the Contractor from the obligation of furnishing all the required materials and completing the Work in full compliance with the terms of the Contract Documents; provided that a reasonable time extension shall be negotiated by the parties.

This section shall not apply if the destruction is by an "Act of God" as defined in Public Contract Code Section 7105 and the loss is in excess of five percent (5%) of the total Contract price.

Section 27.04. OPTION IN EVENT OF A LOSS.

In the event that any destruction or loss should exceed twenty percent (20%) of the value of the construction completed to date, as determined at the end of the preceding month, or is due to an "Act of God" as defined above, the County shall have the option at its sole discretion to terminate this Contract.

Section 27.05. PROVISION FOR TERMINATION OF CONTRACT.

This Contract is subject to termination as provided by Section 4410 and 4411 of the Government Code, being portions of the Emergency Termination of Public Contracts Act of 1949.



ARTICLE 28.

ADDITIONAL PROVISIONS.

Section 28.01. CONFLICT OF INTEREST.

No official of the County who is authorized on behalf of the County to negotiate, make, accept, or approve, any architectural, engineering, inspection, construction, or materials supply contract, or any subcontract in connection with the construction of the Project, or any land acquisition in connection with the Project, shall become directly or indirectly interested personally in the Agreement for Construction or in any part thereof.

No officer, employee, architect, construction manager, attorney, engineer or inspector of or for the County who is authorized on behalf of the County to exercise any executive, supervisory, or other similar function in connection with the construction of the Project shall become directly or indirectly interested personally in the Agreement for Construction or any party thereof.

Section 28.02. NOTICES.

Any notice from one party to the other pursuant to the Contract Documents shall be in writing and shall be dated and signed by the party giving such notice or by a duly authorized representative of such party. Any such notice shall not be effective for any purpose whatsoever unless served in the following manners: If the notice is given to the Contract Administrator, it must be served personally at his office or by depositing same in the United States Mails, in a sealed envelope, correct postage prepaid, and correctly addressed to the address shown the Instructions to Bidders.

If the notice is given to the Contractor, it must be by personal delivery thereof to Contractor or to Contractor's Project superintendent at the Site of the Work, or by depositing the same in the United States Mails, in a sealed envelope, addressed to the Contractor at the place designated in the Bid by the Contractor for the receipt of correspondence.

If the notice is given to a surety of the Contractor, it must be by personal delivery to such surety or by depositing the same in the United States Mails, in a sealed envelope, addressed to such surety or other person at the address last communicated by him to the County. Copies of all such notices shall be delivered to the Contractor.

Section 28.03. NO VERBAL AGREEMENTS.

No verbal agreement or conversation with any officer, agent, or employee of the County, either before, during, or after the execution of the Contract Documents shall affect or modify any term or condition contained in the Contract Documents, nor shall such verbal agreement or conversation entitle the Contractor to any additional payment or time to perform whatsoever under the terms of the Agreement for Construction.

Section 28.04. EXAMINATION OF PROPOSED PROJECT LOCATION AND CONTRACT DOCUMENTS.

By submitting its Bid and executing the Agreement for Construction, the Contractor warrants that prior to bidding it carefully examined the location of the Project, that it carefully reviewed the Contract



Documents, and that it is fully aware of all the Work called for by the Contract Documents, the nature of the Site, and the requirements of all Specification including these General Conditions. The Contractor also warrants that it is familiar with all relevant circumstances and conditions affecting construction projects in Yolo County, California, and the particular site, and has the requisite experience and skill to perform the Agreement for Construction on the Site of the Project.

Section 28.05. NOTICE OF POTENTIAL CLAIMS.

A. The Contractor shall not be entitled to the payment of any additional compensation for any cause, including any act or failure to act, by the County or any of its officers, agents, or employees, or the happening of any event, thing or occurrence, unless he shall have given the County written notice of potential claims as specified herein.

The written notice of potential claims shall set forth the reasons for which the Contractor believes additional compensation should be paid, a firm estimate or accounting of the cost involved, and, insofar as possible, the total amount of the claim.

Such notice must have been given to the County prior to the time that the Contractor shall have performed the work giving rise to the potential claim if based on an act or failure to act by the County, or in all other cases within five (5) days after the happening of the event, thing, or occurrence giving rise to the potential claim or such other time as may be specified herein.

It is the intention of this Section that differences between the parties arising as a result of performance of the Contract shall be brought to the attention of the County at the earliest possible time in order that such matters may be settled, if possible, or other appropriate action promptly taken. The Contractor hereby agrees that he shall have no right to additional compensation for any claim that may be based on any such act, failure to act, event, thing or occurrence, for which no written notice of potential claim was filed as required by this section.

This subsection shall not supersede, but shall be superseded by, any provisions of these Contract Documents that specifically set forth the procedure for the Contractor to give notices of claims to the County in any particular case.

B. Any lawsuit, action or other proceeding seeking damages, costs, compensation or any other recovery, based upon any claim related to the Project, including but not limited to claims of the Contractor, subcontractors, suppliers, laborers and workers, must be preceded by a claim filed in accordance with Government Code Sections 900 et seq.

Section 28.06. CONTINUING WORK IN DISPUTE.

The Contractor shall not delay or suspend performance of the work pending resolution of any dispute or controversy between the County and the Contractor or any other person, firm, or entity involved in the Work.

If these General Conditions specify a procedure to resolve the particular issue, it shall be followed. If no specific procedure is specified, the Contractor shall give notice of the dispute as provided in Section 28.05.



The County's resolution of the issue shall be followed by all parties for the remainder of the Work. If notice has been filed pursuant to Section 28.05, the Contractor is authorized and shall request a Final Change Order to satisfy the unresolved Contract Price or Time claims arising from the issue, pursuant to Section 25.01.

Section 28.07 ASSIGNMENT OF CERTAIN CLAIMS

In entering into this contract, or any subcontract to supply goods, services, or materials pursuant to this contract, the Contractor and any subcontractor offers and agrees to assign to the County all rights, title, and interest in and to all causes of action it may have under Section 4 of the Clayton Act (15 U.S.C. Section 15) or under the Cartwright Act (Chapter 2 (commencing with Section 16700) of Part 2 of Division 7 of the Business and Professions Code), arising from purchases of goods, services, or materials pursuant to the contract or the subcontract. This assignment shall be made and become effective at the time the County tenders final payment to the Contractor, without further acknowledgment by the parties.

Section 28.08 NO THIRD-PARTY BENEFICIARIES

Except where specifically stated otherwise in the Agreement for construction, the promises in the Agreement benefit the COUNTY and CONTRACTOR only. They are not intended to, nor shall they be interpreted or applied to, give any enforcement rights to any other persons (including corporate) that might be affected by the performance or non-performance of this agreement, nor do the parties hereto intend to convey to anyone else any "legitimate claim of entitlement" with the meaning and rights that phrase has been given by case law.

END OF GENERAL CONDITIONS

PROJECT MANUAL

Volume II: Technical Specifications



911 Dispatch Center Tenant Improvement 35 N. Cottonwood Street Woodland, CA 95695 April 16, 2024

PROJECT DESCRIPTION:

The proposed project involves the interior alterations of an existing 911 dispatch center. The work to be performed under this base bid contract includes the demolition of the existing partition walls, flooring finishing, casework, ceiling, light fixtures and HVAC work as well as all labor, materials, equipment, transportation, and services necessary for the construction. The work also includes ADA improvements such as Communication Building Center entrance concrete flatwork and restroom improvements to meet current ADA requirements.

SCOPE OF WORK:

A. MOBILIZATION / DEMOLITION (see sheet A2.1)

Remove existing wall furring, soffit, and sound panel throughout, typical and prepare for new construction.

Remove existing partition wall, door, windows, base and any associated piping and electrical conduit.

Remove existing ceiling, soffits, framing, & Lay-In (Tile and Grid) Ceilings.

Remove existing carpet tiles. New carpet tiles and 4" baseboard by others

Remove existing mechanical diffusers.

Remove all existing all light fixtures (Recessed and indirect).

Remove all existing light control.

Remove all existing mechanical grilles, diffusers, and ductwork.

Remove existing air filter.

Remove existing thermostat. Replace with new and install in new specified location. Remove existing window at IT Room, infill partition wall, and paint finish.

Temporarily remove existing fire alarm device, preserve associated wiring, and prepare for re-installation at new ceiling/wall.

Temporarily remove existing fire sprinkler head and prepare for re-installation at new ceiling.

Temporarily remove exiting signs, preserve associated wiring, and prepare for reinstallation at new ceiling.

B. WALLS AND CEILING (see sheet A2.2)

Provide and install new wall furring at exterior wall.

Provide and install wall backing for all TVs.

Provide and install new suspended ceiling system.

Provide and install new framed gypsum board soffit.

Provide and install cont. R-13 Batt Insulation.

Infill partition wall at IT Room.

CASEWORK (see sheet A2.2)

Provide and install Built-In Cabinet.

Provide and install louver doors, and door hardware.

C. PAINTING

Furnish all labor, materials, tools and equipment necessary to complete the painting job. Paint with an undercoat plus two coats of approved finish color for walls, built-in cabinet, and door. Ensure each coat of paint is uniform in color, thickness, and texture and free of runs, sags, blisters, or other discontinuities.

Remove all hardware, hardware accessories and similar items in place and not to be painted or provide surface applied protection prior to surface preparation and painting operations. After completions re-install all removed items, Exceptional care must be taken to assure tidiness of work. Suitable temporary covers, masking, drop sheets, drapes and/or barriers shall be provided and maintained effectively where necessary to protect carpeting and furniture or other finishes that are to be painted or not to ensure what they are not exposed to paint and put at risk. These are to be removed when protection is no longer required. Provide "Wet Paint" signs as required to protect newly painted surfaces. Carefully remove and reinstate paint splatters from adjacent surfaces. Upon completion of the work all paint cans, other materials, containers, debris and protective coverings shall be cleaned up and removed from site and the Contractor shall leave the area in a clean, neat, and orderly condition.

Paint colors:

Wall Color: Behr Sand Drift (N310-1)

Ceiling: Benjamin Moore 2122-70-Snow White

D. ELECTRICAL (see sheet A2.2, E0, E1, E2)

Provide and install new power for modular furniture in Comm Center 110. Provide and install new power for wall TVs.

Provide and install new lighting fixtures (indirect and direct) specified on the plan. Provide and install new controls in Comm Center 110.

Provide and install new thermostat. TBD Location.

E. MECHANICAL (see sheet A2.2, M0, M1, E2)

Provide and install new grilles, diffusers, ductwork, and associated components for Comm Center 110. Balance existing fan coil for new outside air ventilation rate and supply airflows listed on the plans.

F. ADA IMPROVEMENTS

a. Building Main Entrance (see sheet A1.0, A1.1, A2.0)

Remove existing concrete section for new concrete flatwork at entrance. Route Existing RWL under new concrete. Daylight at face of curb.

Remove existing threshold and replace with new disabled accessible threshold.

Provide and install NEW ISA Sign.

b. **ADA Parking** (see sheet A1.0, A1.1)

Grind and chipseal as required to repair and flatten asphalt at loading zone to even surface.

Re-stripe disabled parking loading zone as required. Provide detectable warning strips.

Provide detectable warning surface on all curb ramps. Medium broom finish, non-colored concrete at all curb ramps.

c. **Restroom Improvement** (see sheet A1.0, A1.1, A2.3)

1. **OPTION 1**

Existing toilet with offset flange

Remove existing toilet – store for reuse.

Add offset flange to toilet so that the center of toilet is 17"-18" from existing wall.

Remove existing flooring, store base for reuse.

Reuse existing toilet or provide new to offset location.

Remove existing Urinal and cap off plumbing.

Repair and clean existing wall where urinal was removed.

Demo existing countertop and sink.

Existing grab bars to remain.

Existing toilet tissue dispenser to remain.

Existing paper towel dispenser / waste receptacle combo.

Existing restroom partition to be removed.

Existing mirror – remove as required for construction of new countertop, store for reuse.

Existing soap dispenser – remove as required for construction of new countertop, store for reuse.

Provide and install new sheet vinyl flooring, wall base to remain.

Relocated/New toilet with offset flange.

Cap off plumbing as required and repair/clean wall for like new finish.

Provide and install new solid surface countertop and sink. Specs per Yolo County standard plumbing fixtures.

Provide and install new restroom partition. Color and finish TBD.

Existing restroom signage see Detail 4 sheet A2.3

Finishes:

- Floors: Luxury Vinyl Tile: Advantage II-3mm, 7" x 48", 20 mil-Hickory Snow
- Flooring Base Cove: Target-Johnsonite Baseworks-Thermoset Rubber (type TS) 4"-Pebble

2. **OPTION 2**

Existing toilet to remain – furr out wall to required distance.

Remove existing grab bar, paper towel dispenser, and toilet seat cover dispenser – store for reuse.

Carefully remove existing FRP wall and wall base, store for reuse.

Add wall furring to existing wall so that center of toilet is 17-18” from face of new wall.

Reuse FRP wall, wall base, grab bars, paper towel dispenser, and toilet seat cover dispenser.

Urinal to be relocated to accommodate for new countertop and sink. Demo existing countertop and sink.

Existing restroom partition to be removed.

Existing mirror – remove as required for construction of new countertop, store for reuse.

Existing soap dispenser – remove as required for construction of new countertop, store for reuse.

Provide and install new sheet vinyl flooring, wall base to remain.

Existing restroom signage see Detail 4 sheet A2.3

Finishes:

- Floors: Luxury Vinyl Tile: Advantage II-3mm, 7” x 48”, 20 mil-Hickory Snow
- Flooring Base Cove: Target-Johnsonite Baseworks-Thermoset Rubber (type TS) 4”-Pebble

The Contractor is advised to perform their own due diligence to confirm that bid costs for site improvements are accurate. All measurements are to be confirmed on site by the contractor. It is the contractor's responsibility to ascertain and confirm their own measurements. Any materials, equipment and finishes would need submittals if not specified in the scope of work. Upon completion of all work, the Contractor shall sufficiently clean the work area. All construction waste generated shall be disposed of properly off site at Contractor's responsibility.

The awarded contractor will be required to collect the approved construction plan set from the Yolo County Community Services Building Department located at 292 West Beamer Street., Woodland, CA 95695. It is expected that the contractor will comply with all relevant regulations and standards, and that the construction plan will be implemented according to the approved guidelines.

3. **OPTION 2**

Existing toilet to remain – furr out wall to required distance.

Remove existing grab bar, paper towel dispenser, and toilet seat cover dispenser – store for reuse.

Carefully remove existing FRP wall and wall base, store for reuse.

Add wall furring to existing wall so that center of toilet is 17-18” from face of new wall.

Reuse FRP wall, wall base, grab bars, paper towel dispenser, and toilet seat cover dispenser.

Urinal to be relocated to accommodate for new countertop and sink.

Demo existing countertop and sink.

Existing restroom partition to be removed.

Existing mirror – remove as required for construction of new countertop, store for reuse.

Existing soap dispenser – remove as required for construction of new countertop, store for reuse.

Provide and install new sheet vinyl flooring, wall base to remain.

Existing restroom signage see Detail 4 sheet A2.3

Finishes:

Floors: Hickory Snow (GSD standard)

Base Cove: Pebble (GSD standard)

The Contractor is advised to perform their own due diligence to confirm that bid costs for site improvements are accurate. All measurements are to be confirmed on site by the contractor. It is the contractor's responsibility to ascertain and confirm their own measurements. Any materials, equipment and finishes would need submittals if not specified in the scope of work. Upon completion of all work, the Contractor shall sufficiently clean the work area. All construction waste generated shall be disposed of properly off site at the Contractor's responsibility.

The awarded contractor will be required to collect the approved construction plan set from the Yolo County Community Services Building Department located at 292 West Beamer Street., Woodland, CA 95695. It is expected that the contractor will comply with all relevant regulations and standards, and that the construction plan will be implemented according to the approved guidelines.