



March 28, 2024

Ms. Kimberly Villa  
CSA Manager  
Department of Community Services  
County of Yolo  
292 West Beamer Street  
Woodland, CA 95695

## **Traffic Calming Evaluation for the El Macero Community**

Dear Ms. Villa;

W-Trans has completed a review of existing traffic conditions in the El Macero Community in the County of Yolo adjacent to the City of Davis in response to a request from the El Macero County Service Area Advisory Committee (CSA). Concern has been expressed by residents regarding the speed of traffic through the community, particularly on El Macero Drive and Country Club Drive, and our assistance has been requested to review conditions and develop potential countermeasures. The purpose of this letter is to document this review and to provide a “toolkit” of potential measures to achieve desirable speeds while still accommodating emergency response vehicles.

### **Existing Conditions**

El Macero Drive forms a perimeter around the El Macero community and consists of three segments: North El Macero Drive and South El Macero Drive, which are each approximately a mile in length each, and East El Macero Drive, which is about half a mile long. Each end of Country Club Drive connects to North El Macero Drive, the street is about a mile long, and it extends further into the interior of El Macero, providing access to the community clubhouse. Each of these streets is 40 feet wide with one 11-foot travel lane in each direction, a marked centerline, and a posted speed limit of 25 miles per hour (mph). There are marked and signed nine-foot-wide bicycle lanes in each direction for the entirety of El Macero Drive and Country Club Drive, though these lanes are commonly used for street parking. There are curbs and gutters, but no sidewalks. Due to the lack of sidewalk many properties have landscaping that extends to the edge of the roadway, in an area that would be clear and provide open sight lines if sidewalk were present. El Macero Drive and Country Club Drive are generally flat, with large horizontal curve radii.

In addition to motor vehicle and bicycle traffic, golf carts are common throughout the community. They are typically slower than motor vehicles and are driven in the bicycle lanes when parked vehicles are not present.

### **Operational Review**

#### **Speeds**

In January 2024, a field visit was conducted to a series of locations along El Macero Drive and Country Club Drive on a typical weekday with clear weather. The speeds of several motor vehicles were measured during this visit, with a range of travel speeds from 21 mph to 35 mph recorded. It is noted that while excessive speeds (more than 10 mph over the speed limit) were not observed at the time of the field visit, the relatively flat, straight, and visually unobstructed geometry of these streets does not discourage excessive speeding.

#### **Collisions**

The collision histories of El Macero Drive and Country Club Drive were reviewed for the 10-year period spanning January 1, 2014, to December 31, 2023. During this period, there were six collisions reported on these two streets, including three on El Macero Drive, two on Country Club Drive, and one at the eastern intersection of El Macero Drive/Country Club Drive. It is understood that residents have documented a number of additional crashes into fixed objects, such as mailboxes, that were not reported.

Two of the reported collisions were primarily attributed to driving under the influence, and one collision each was reported as the result of unsafe starting or backing, improper turning, a factor other than the driver, and an unknown reason. There were four crashes with fixed objects, one with another driver, and one with a minor on a scooter. Two collisions resulted in “complaint of pain” injuries where involved parties reported whiplash, soreness, or other pain but for whom visible injuries were not present. The other four collisions were reported as “property damage only.” Table 1 lists each of the reported collisions and the details available from the SWITRS database.

**Table 1 – Collision Rates for the Study Intersections**

<b>Date &amp; Time</b>	<b>Location</b>	<b>Description</b>	<b>Severity</b>
4/26/2016 10:55 a.m.	S El Macero Dr 179' west of Clubhouse Dr	WB driver entered traffic and failed to yield to a WB driver	Property Damage Only
11/8/2018 11:53 a.m.	N El Macero Dr/ Country Club Dr (east)	NB driver collided with a fixed object due to a factor other than the driver	Complaint of Pain
7/12/2020 7:20 p.m.	S El Macero Dr 625' west of Golfview Cir	WB driver collided with a WB minor on a scooter for an unknown reason	Complaint of Pain
6/9/2021 8:10 p.m.	Country Club Dr 110' south of N El Macero Dr (west)	NB driver under the influence ran off the road and collided with a fixed object	Property Damage Only
9/6/2022 8:24 p.m.	N El Macero Dr 380' east of Mace Blvd	EB driver made a turn into a fixed object	Property Damage Only
11/6/2023 10:50 p.m.	Country Club Dr/ Country Club Cir	EB driver under the influence ran off the road and collided with a fixed object	Property Damage Only

Notes: WB = westbound; NB = northbound; EB = eastbound

It is notable that while there were no collisions attributed in the past ten years to speeding, often if there is another factor such as driving under the influence, that factor takes precedence in reporting. The prevalence of fixed object collisions (four of the six reported crashes) dispersed throughout the El Macero community indicates that speeding may be present. For example, the most recent reported collision was primarily attributed to driving under the influence, but the alleged path of travel of the vehicle and displacement of landscaping and fixed objects along this path of travel as anecdotally communicated by a resident indicate that the motorist was likely driving well above the speed limit.

## **Potential Traffic Calming Measures**

Consideration was given to measures that would be appropriate for a residential street and guidance provided by representatives of the CSA. Measures such as rumble strips which, while effective on arterial streets, were not considered as they have the undesirable side-effect of generating noise that would impact adjacent homes.

Both horizontal and vertical deflection measures were considered as both have the ultimate goal of reducing speeds by making it less comfortable for a driver to travel at a higher speed. Special consideration was given to the prevalence of golf carts and bicycles in the El Macero community. Speed feedback signs are also included as a potential traffic calming measure.

Additionally, though not intended to be a speed control device, consideration was given to the addition of stop controls at intersections along El Macero Drive and Country Club Drive as it is understood that this measure has the greatest degree of support by local residents. It is noted that the California *Manual on Uniform Traffic Control Devices* (CA-MUTCD) specifically states that “STOP signs should not be used for speed control.” This is because the

installation of all-way stop controls is generally warranted by high volumes on the minor street, as low minor street volumes can lead to drivers on the major street violating the requirement to stop. However, in light of the residents' specific request that stop signs be evaluated, they were considered as part of this review.

## Vertical Measures

**Speed Humps** are pavement areas raised four to six inches and placed across the road. They are similar to the speed bumps commonly found in shopping centers but have a higher design speed that is more suitable for public streets, as well as typically having cutouts for emergency vehicles to proceed through without vertical deflection. Edge treatments would need to be provided such as extending the humps into the bicycle lanes or providing raised islands between the humps and bicycle lanes to prevent drivers from using the bicycle lanes to navigate around the speed humps. An example is presented in Plate 1.

**Speed Cushions** consist of either recycled rubber or asphalt, are raised about three inches in height and placed in groups of three across the road. The length of each cushion is about ten feet. Speed cushions are quicker to install and less costly but offer less speed reduction than speed humps. An example is presented in Plate 2.



**Plate 1** Example of Speed Humps



**Plate 2** Example of Speed Cushions

## Horizontal Measures

**Chokers and Neckdowns** are midblock curb extensions that reduce roadway width. They are typically designed to widen sidewalks and accommodate landscaping. A gap can be provided between a choker island and curb to enable bicyclists and golf carts to pass through without having to enter the street to pass by the traffic calming device. Striping would need to be provided to avoid street parking adjacent to and blocking this gap. Chokers and neckdowns also provide the opportunity to plant street trees and other vegetation closer to the roadway centerline, potentially reducing speeding. Per the Contra Costa County *Neighborhood Traffic Management Program*, trees "give the impression of a narrower street and thus slow traffic. Mature trees can create a tunnel effect that discourages excessive speeding."

**Bulb-outs and Curb Extensions** are extensions at intersections that reduce the curb-to-curb roadway width. They tighten the corner curb radii, reducing the speeds of turning motorists, as well as shortening crossing distances. Bulb-outs and curb extensions work like chokers and neckdowns to narrow the roadway at an intersection. An example is presented in Plate 3.

**Chicanes** are curb extensions that form a curvilinear alignment by alternating from one side of the roadway to the other. The effect can also be created by alternating on-street parking from one side of the street to the other.

Chicanes are a series of bulb-outs, curb extensions, or other chokers designed to narrow streets, forcing traffic to slow and maneuver through the measures. An example is presented in Plate 4



**Plate 3** Example of a Bulb-out



**Plate 4** Example of a Chicane

## Speed Feedback Signs

Speed feedback signs include a radar that measures the speed of an oncoming vehicle and reports it to the driver and are best paired with a speed limit sign to remind drivers of the posted speed limit. Research has determined that speed feedback signs can reduce speeds by six to eight mph when placed in speed transition zones, or areas where the speed limit decreases (*Long-Term Effectiveness of Dynamic Speed Monitoring Displays (DSMD) for Speed Management at Speed Limit Transitions*, Sandberg et al., 2009). Therefore, placing such signs at the entrance to the El Macero community may be effective in notifying drivers of the reduced speed limit (25 mph) in the community compared to 35 mph on Mace Boulevard preceding the community.

## All-Way Stop Controls

Consideration was given to the appropriateness of installing all-way stop controls at various locations along El Macero Drive and Country Club Drive based on the classification of these streets at the various intersections. The criteria typically applied to determining if stop controls are needed, or warrants, differ for collectors versus local streets. According to the California Road System Functional Classification map, North El Macero Drive is a major collector from Mace Boulevard to Country Club Drive, and Country Club Drive is a major collector along its entire length. The remaining streets in the community are considered local streets.

The following locations were considered for all-way stop controls. The street classifications at each location are indicated in parentheses. Note that while there are other intersections along both El Macero Drive and Country Club Drive, the intersecting streets are either cul-de-sacs or otherwise such short segments that the volumes would be very low, thereby resulting in such an imbalance in volumes as to likely lead to substantial non-compliance for the reasons discussed above.

- North El Macero Drive/Country Club Drive East (collector/collector)
- Country Club Drive/Clubhouse Drive (collector/local)
- South El Macero Drive/Fairway Estates (local/local)
- South El Macero Drive/Clubhouse Drive (local/local)

The CA-MUTCD provides warrant criteria for converting a one- or two-way stop-controlled intersection to all-way stop controls; these criteria are most appropriate for application to the intersections where one or both streets are collectors. Under the All-Way Stop Control (AWSC) warrant criteria, at least one of the following four conditions must be satisfied to warrant AWSC installation.

1. A traffic signal has been warranted at the intersection, and the AWSC is an interim measure;
2. Five or more crashes in a 12-month period have occurred that are susceptible to correction by installing AWSC, such as right-turn, left-turn, and right-angle collisions;
3. The major street vehicle volume averages at least 300 vehicles per hour for each of eight hours on a typical day, the combined vehicle, pedestrian, and bicycle volume on the minor street averages at least 200 units per hour during the same eight hours, the minor street vehicular traffic faces an average delay of 30 seconds per vehicle during the peak hour, or 70 percent of the above values if the 85<sup>th</sup> percentile approach speed on the major street exceeds 40 miles per hour; and/or
4. The above two conditions are both satisfied to 80 percent, meaning four crashes in 12 months, 240 vehicles per hour on the major street, 160 units per hour on the minor street, and 24 seconds of delay.

Based on traffic volume data provided, the volumes on El Macero Drive and Country Club Drive are less than 1,000 vehicles per day, and therefore it is clear that the minimum volume of 300 vehicles per hour for each of eight hours would not be met. Similarly, the collision history detailed above indicates that there was no more than one crash at any single location during the five-year study period, so the crash criterion is not met.

In addition to the above, the MUTCD also has four optional warrants. These alone are not enough to warrant installation of AWSC but may be used in conjunction with engineering judgment to alleviate minor shortfalls in fulfilling the above criteria, as well as addressing unusual cases. The four optional warrants are:

1. The need to control left-turn conflicts;
2. The need to control the interaction of pedestrians and vehicles near heavy pedestrian traffic generators;
3. Locations where a driver stopped at the minor street approach is unable to assess conflicting traffic due to poor sightlines; and/or
4. At the intersection of two neighborhood collectors where installing AWSC will improve operations.

North El Macero Drive/Country Club Drive East meets the fourth optional warrant in that it is the intersection of two neighborhood collectors. Since the volume on East El Macero Drive (or east of this intersection) is similar to the volume for Country Club Drive, all-way stop controls could provide a balance and improve operation by reducing delay on the northbound Country Club Drive approach. Installation of all-way stops could therefore be justified at this location.

Country Club Drive/Clubhouse Drive is an intersection of a collector and local street, so would not warrant all-way stop controls under the fourth criterion. There does not appear to be a reason for left-turn conflicts and with no sidewalks in the area, pedestrian traffic is presumably light. A review of sight lines using Google Earth's Street View indicates that sight lines are affected by trees along the south side of the street and may be less than the 200 feet recommended for a 25-mph approach speed. All-way stop controls may, therefore, be appropriate at this location to address sight line impediments.

Guidelines were suggested in *WesternITE*, January 1999 (the publication of the Western District of the Institution of Transportation Engineers), for use with neighborhood streets. These guidelines can be applied where two local streets intersection one another such as the two locations on South El Macero Drive and include the following issues to be considered in evaluating the need for all-way stop controls.

- excessive volume
- high number of collisions
- limited visibility
- excessive speeds
- crossing residential collectors
- residential frontage

An intersection meeting two of the criteria is considered a candidate for an all-way stop sign installation.

As drivers traveling at what is considered by residents to be an excessive speed is the primary reason for this analysis, it is assumed that this criterion is met. A review of conditions at South El Macero Drive at both Clubhouse Drive and Fairway Estates using Street View indicates that trees and landscaping along the north side of South El Macero Drive may limit sight lines and present a visibility obstacle. This would be a second criterion met and may indicate the need for all-way stop controls at one or both of these locations.

### Recommended Measures

Based on our review of current conditions, it is recommended that the County and CSA consider the above measures for traffic calming in the El Macero community. Specifically, the following measures are suggested.

- Consideration could be given to installing all-way stop controls at one or all of the four locations evaluated. While the warrants for all-way stop controls are not met based on the criteria most commonly used, all four locations have operational issues that could potentially be addressed through this change to traffic controls.
- Install speed feedback signs at each entrance into the community, including one device on each of the eastbound shoulders of North El Macero Drive, Country Club Drive, and South El Macero Drive.

If stop signs are installed, their efficacy should be evaluated following a trial period of not less than three months. At that time consideration could be given to the following measures if further traffic calming is still desired.

- Install a combination of speed humps and choker islands along El Macero Drive and Country Club Drive, spaced at 300 to 800 feet and avoiding alignment with driveways, intersections, or surface-level utilities. These devices should accommodate bicyclists and golf carts in the designated bicycle lanes as well as emergency vehicles.
- In terms of planning-level construction cost estimates, speed feedback signs are approximately \$7,500 per location, and speed humps and chokers are about \$15,000 per location. A combination of choker islands and speed humps would likely cost about \$25,000 per installation.

Enclosed is an aerial of the El Macero community with locations for stop signs as well as other potential traffic calming devices highlighted as well as some samples of designs for the various measures available from various agencies through the country.

We hope this information is helpful to the County and CSA. We look forward to discussing these options with you and assisting you in determining your next steps. Thank you for giving us the opportunity to provide these services.

Sincerely,



Kevin Carstens, PE (Civil, Traffic)  
Traffic Engineer

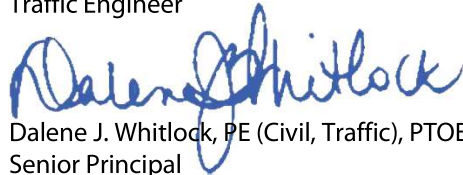

Dalene J. Whitlock, PE (Civil, Traffic), PTOE  
Senior Principal

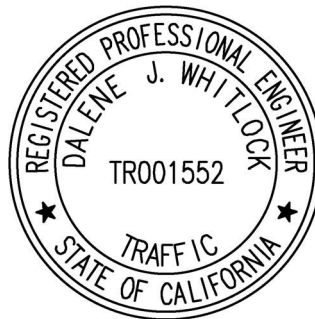

DJW/krc/YOX007.L1

Enclosures: Potential Device Installation Locations, Sample Plans for Measures Considered

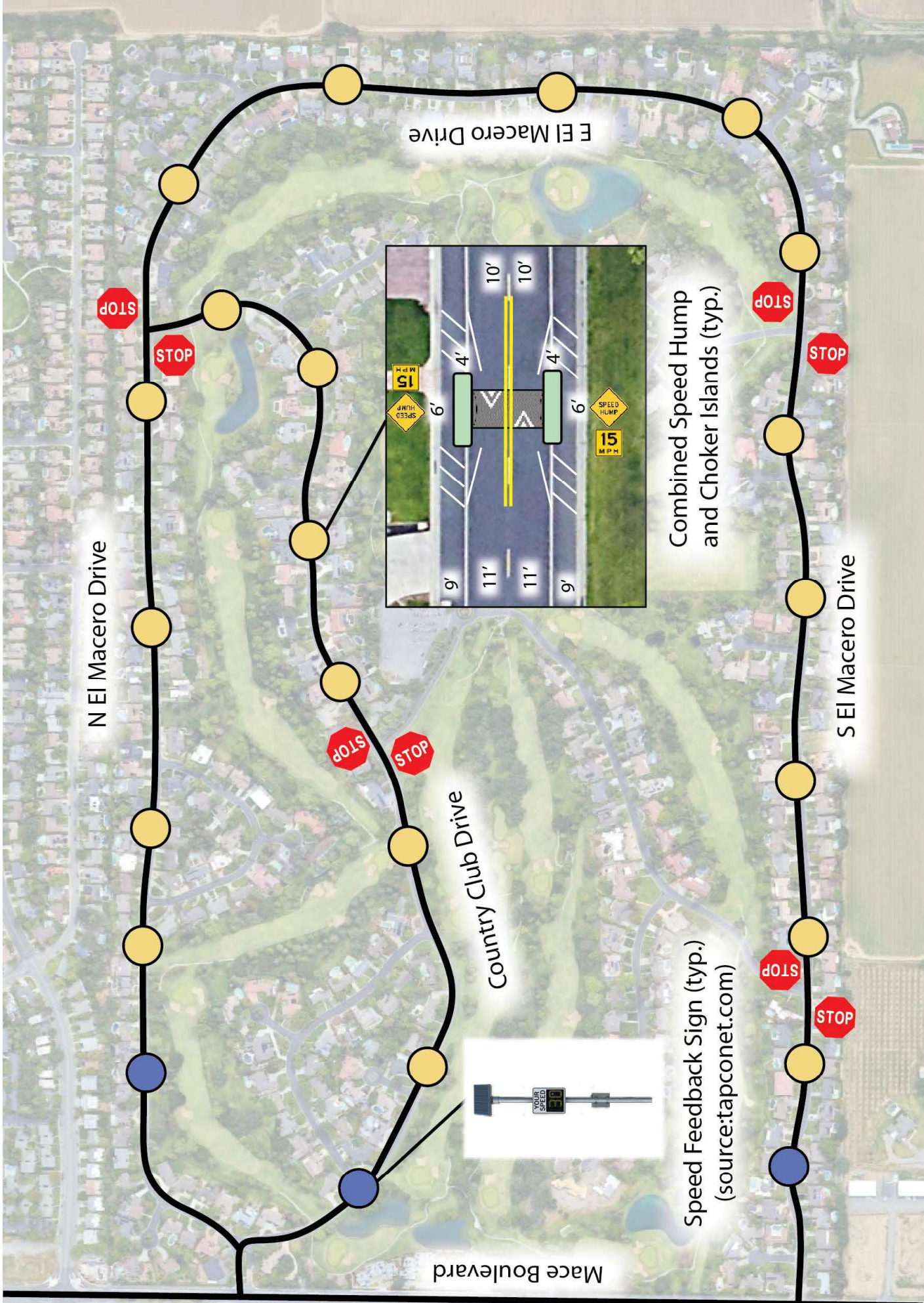

N El Macero Drive

E El Macero Drive

S El Macero Drive

Country Club Drive

Mace Boulevard

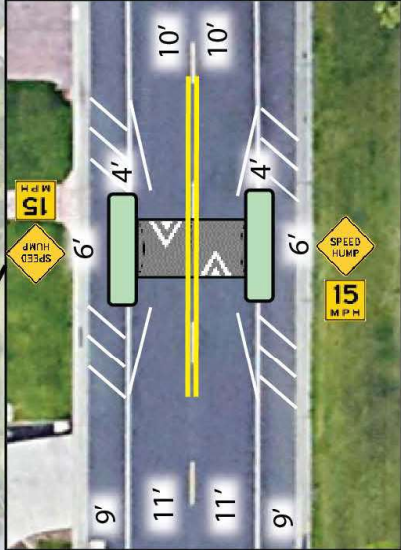

Combined Speed Hump and Choker Islands (typ.)

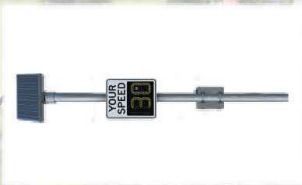

Speed Feedback Sign (typ.)  
(source:tapconet.com)



# CITY OF CALISTOGA SPEED CUSHION DETAIL

PLAN VIEW

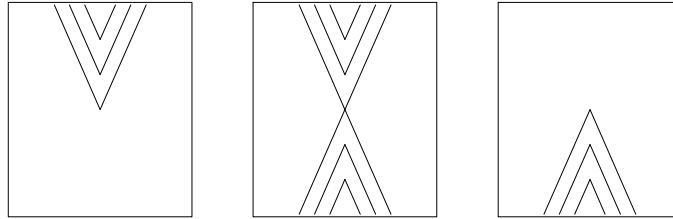

NOTE: CENTER SPEED CUSHION CENTERED IN ROAD

SECTION VIEW

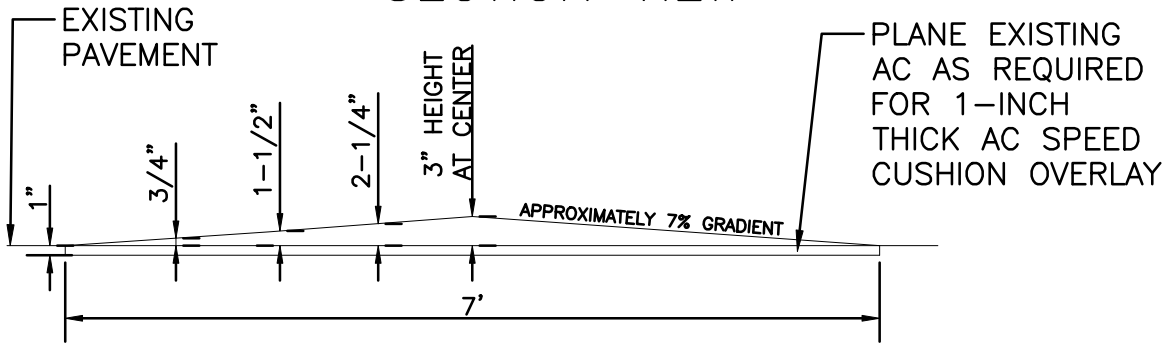

TYPICAL SPEED CUSHION DIMENSION

7' L x 6' W x 3" H  
TWO-WAY EXAMPLE

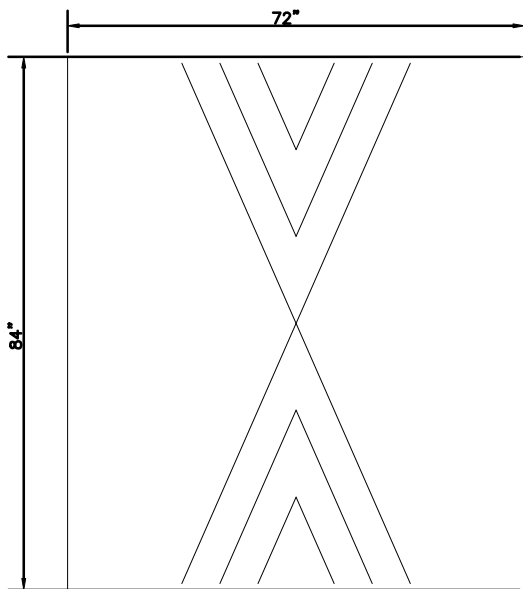

TRIANGLE DIMENSION

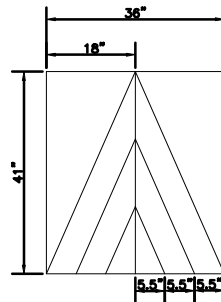

ONE-WAY EXAMPLE

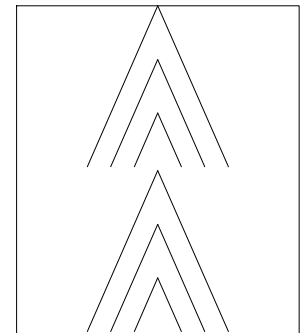

NOTES:

1. INSTALL SIGNS AND MARKINGS PER CA MUTCD STANDARDS.
2. INSTALL SPEED HUMP SIGN (W17-1) AT EACH SPEED HUMP IN BOTH DIRECTIONS.
3. INSTALL SPEED HUMP AHEAD (W17-1 & W16-9P) SIGN IN ADVANCE OF THE FIRST SPEED HUMP IN EACH DIRECTION APPROXIMATELY 150 FEET.
4. MINIMUM STREET WIDTH FROM FACE OF CURB TO FACE OF CURB IS 32 FEET.
5. IT MAY BE NECESSARY FOR VEHICULAR TRAFFIC TO PULL TO THE RIGHT AND ALLOW AN OPPOSING EMERGENCY VEHICLE TO PASS.

**SIGNS**

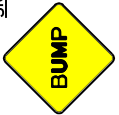

WB-1  
W17-1

**Construction Notes:**

All construction should be executed in accordance with District Department of Transportation policies and regulations.

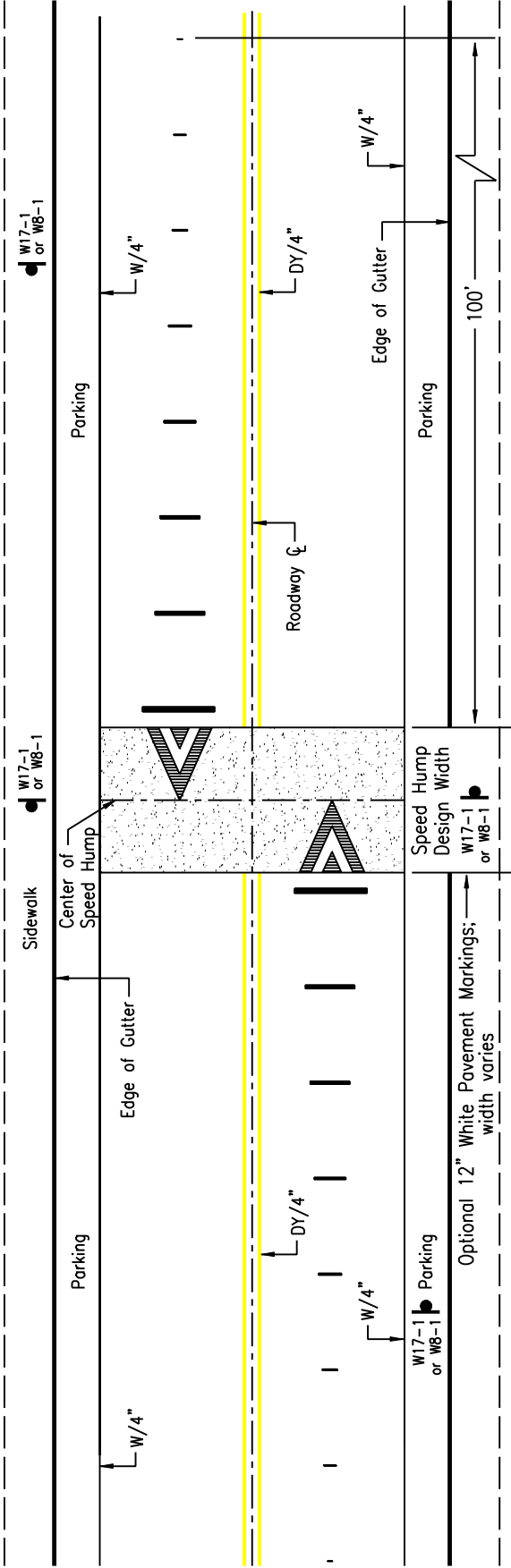

**Figure 5A: Typical Advance Warning Markings For Speed Humps**

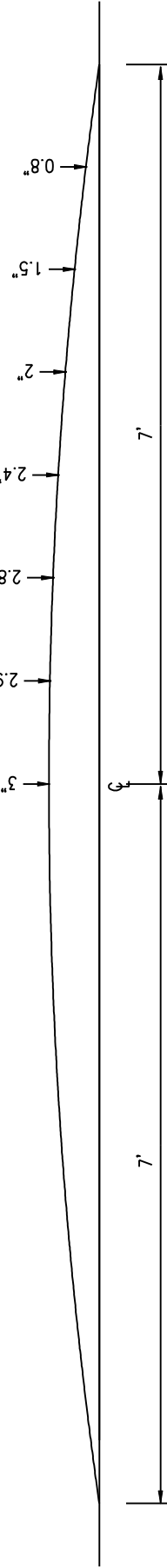

**Figure 5B: Speed Hump - Parabolic Crown (Tolerance +0.5)**

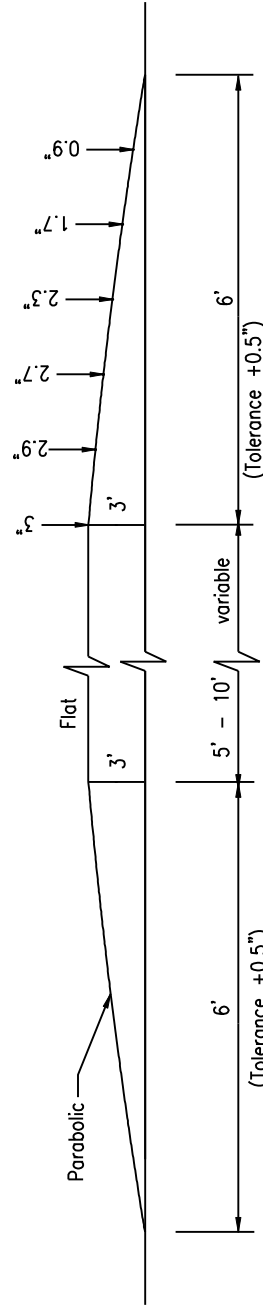
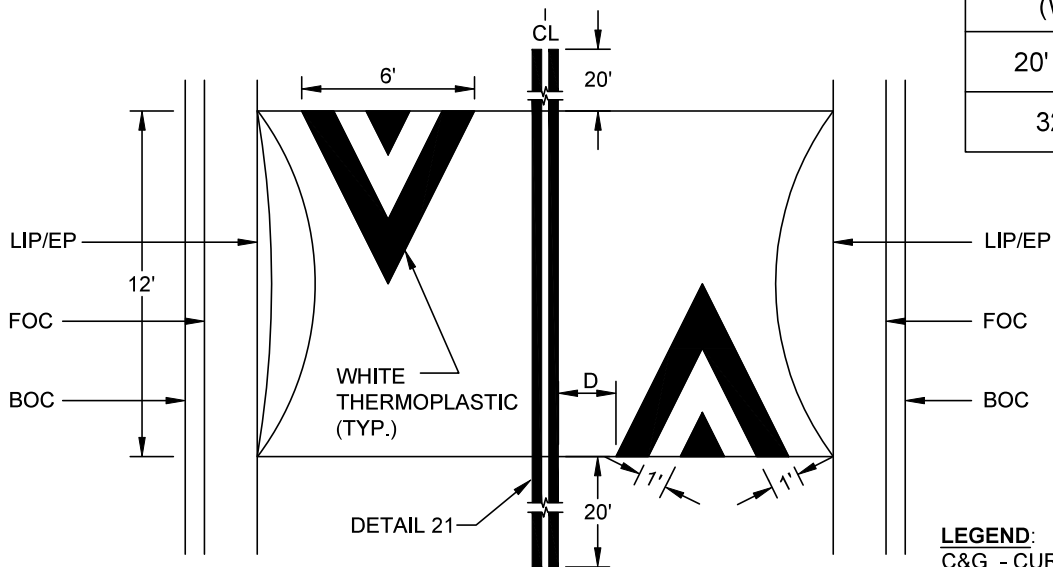
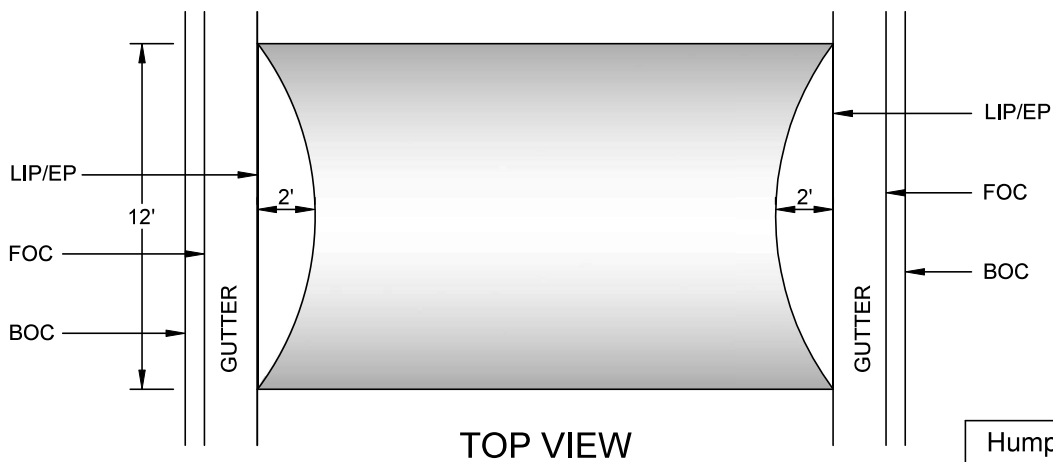
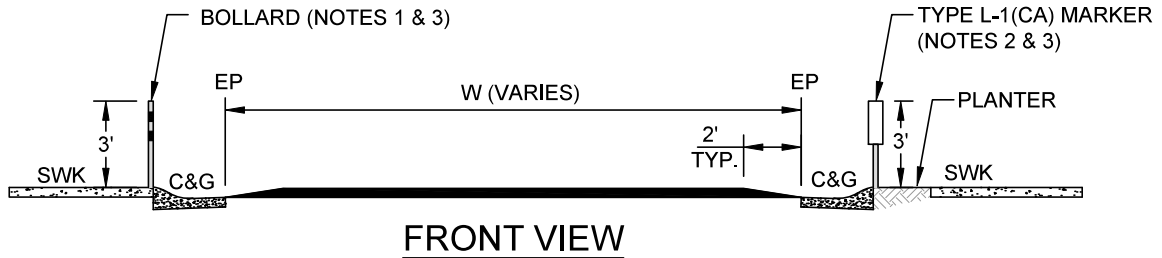
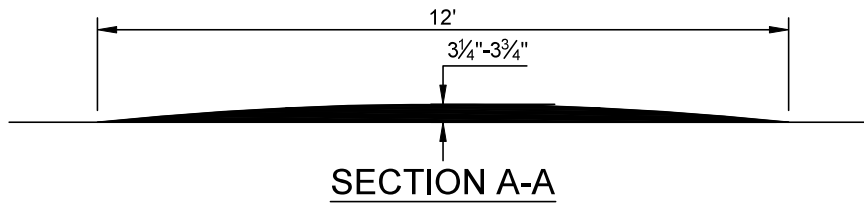

**Figure 5C: Speed Table - Flat Crown**

**LEGEND**

- W/4" SOLID WHITE LINE/WIDTH
- DY/4" DOUBLE SOLID YELLOW LINE/WIDTH

District Department of Transportation Traffic Services Administration	
APPROVED BY:	DRAWING TITLE: Typical Advance Warning For Speed Humps
DATE:	SCALE: N.T.S.
	DGN.NO. A-05



Hump Width (W)	(D)
20' - 32'	2'-0"
32'+	3'-0"

**LEGEND:**  
 C&G - CURB AND GUTTER  
 LIP/EP - EDGE OF PAVEMENT  
 FOC - FACE OF CURB  
 BOC - BACK OF CURB  
 SWK - SIDEWALK

**NOTES:**

- BOLLARD TO BE INSTALLED ON SIDEWALKS WITH ROLLED CURBS. SEE CITY STANDARD DWG. NO. T-230.
- TYPE L-1(CA) MARKER TO BE INSTALLED ON PLANTER/DIRT WITH ROLLED CURBS OR UNIMPROVED STREETS. SEE CITY STANDARD DWG. NO. T-210.
- NO BOLLARD OR TYPE L-1(CA) MARKER IS NEEDED WHERE TYPE 2 CURB & GUTTER IS PRESENT.

REV.	DATE	DESCRIPTION
△		
△		
△		

## SPEED HUMP DETAILS

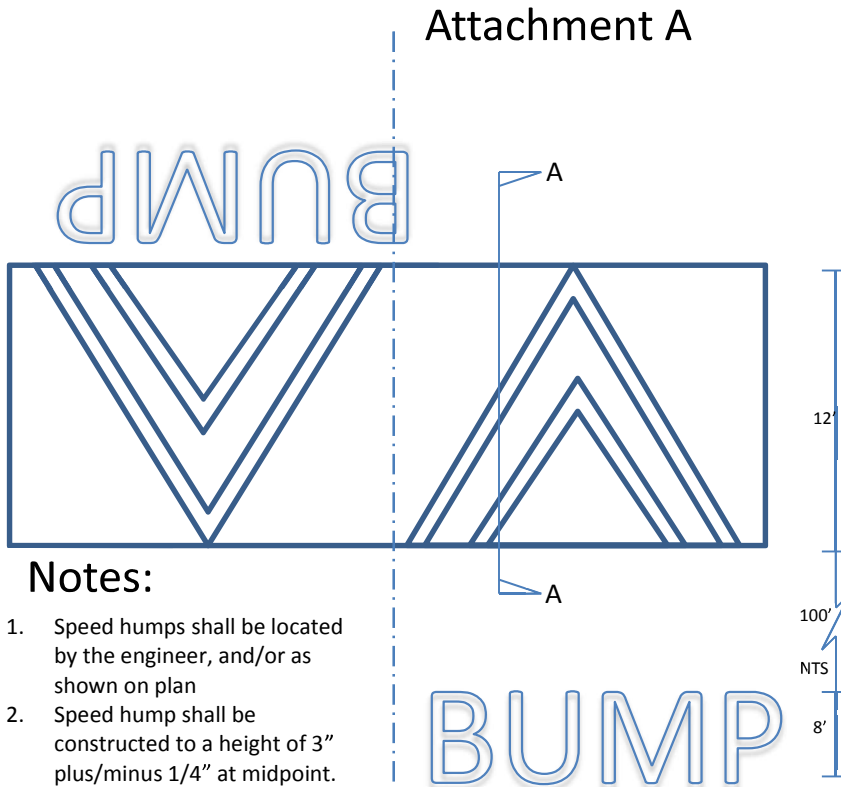

### Notes:

1. Speed humps shall be located by the engineer, and/or as shown on plan
2. Speed hump shall be constructed to a height of 3" plus/minus 1/4" at midpoint. The corresponding shape follow a circular arc (see Section A-A).
3. Asphalt shall be placed in 2 lifts. 1" minimum at highest point.
4. Asphalt shall be Type III-C3-AR4000 (1/2") with 6% asphalt binder or as directed by the engineer.

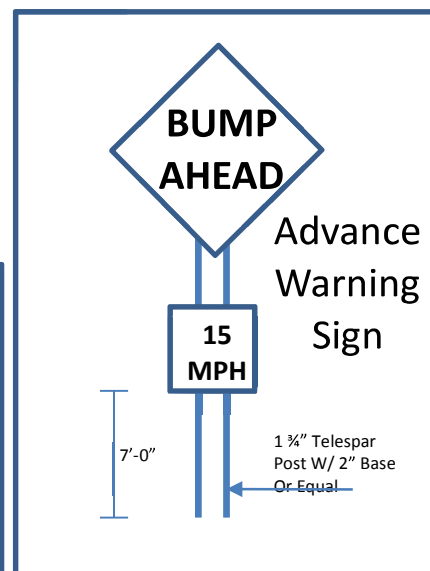
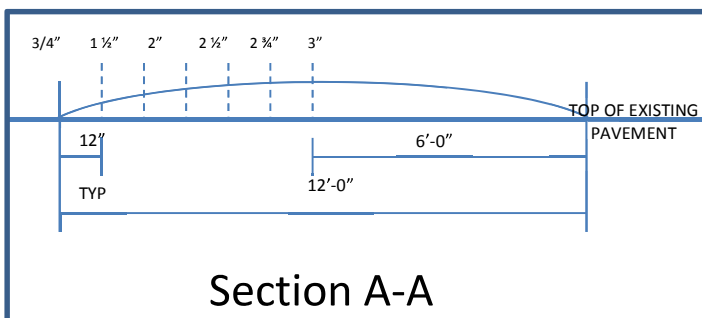

### ATTACHMENT B

# CITY OF CALISTOGA SPEED CUSHION DETAIL

## PLAN VIEW

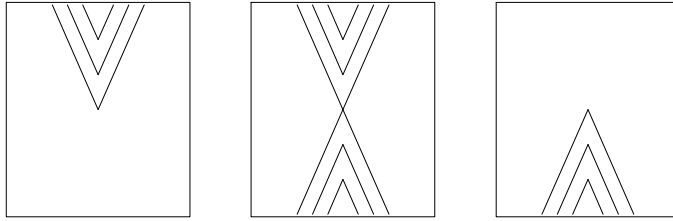

NOTE: CENTER SPEED CUSHION CENTERED IN ROAD

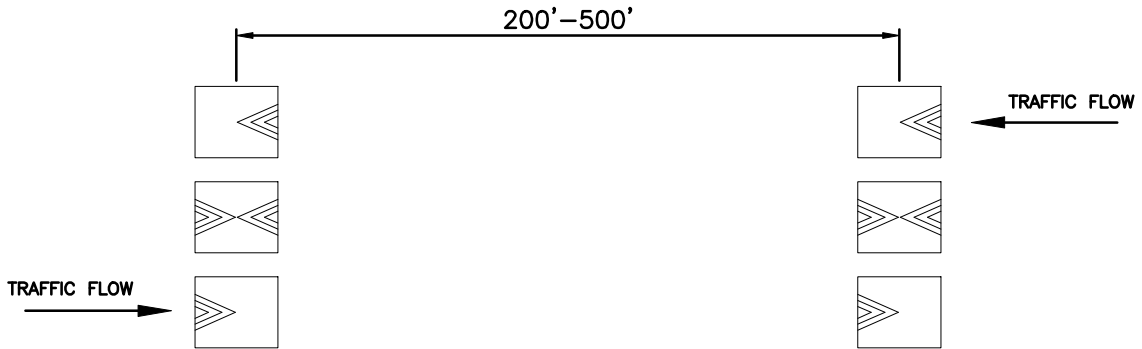

## TYPICAL SPEED CUSHION DIMENSION

7' L x 6' W x 3' H  
TWO-WAY EXAMPLE

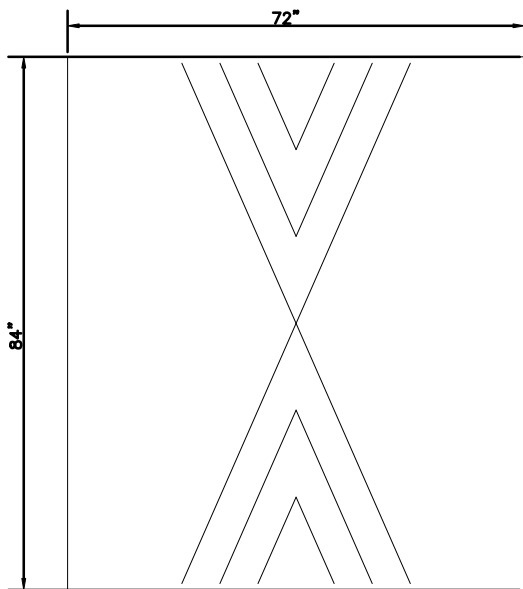

## TRIANGLE DIMENSION

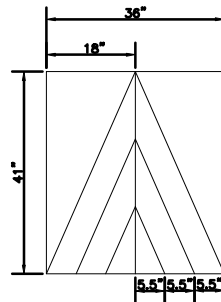

## ONE-WAY EXAMPLE

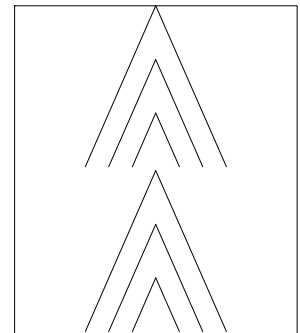

### NOTES:

1. INSTALL SIGNS AND MARKINGS PER CA MUTCD STANDARDS.
2. INSTALL SPEED HUMP SIGN (W17-1) AT EACH SPEED HUMP IN BOTH DIRECTIONS.
3. INSTALL SPEED HUMP AHEAD (W17-1 & W16-9P) SIGN IN ADVANCE OF THE FIRST SPEED HUMP IN EACH DIRECTION APPROXIMATELY 150 FEET.
4. MINIMUM STREET WIDTH FROM FACE OF CURB TO FACE OF CURB IS 32 FEET.
5. IT MAY BE NECESSARY FOR VEHICULAR TRAFFIC TO PULL TO THE RIGHT AND ALLOW AN OPPOSING EMERGENCY VEHICLE TO PASS.

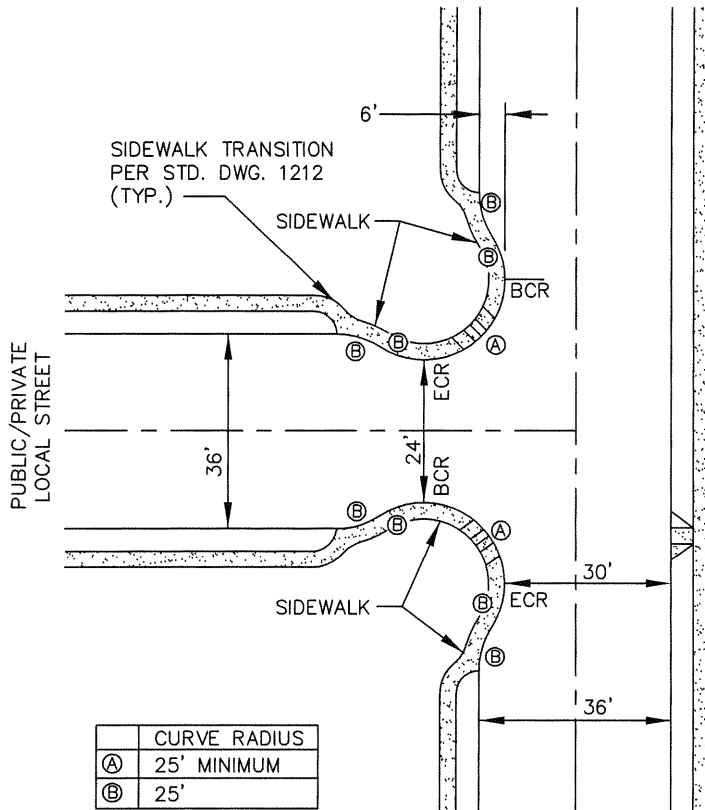

	CURVE RADIUS
(A)	25' MINIMUM
(B)	25'

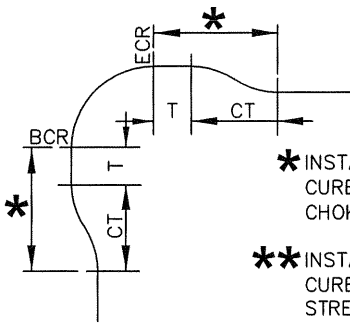
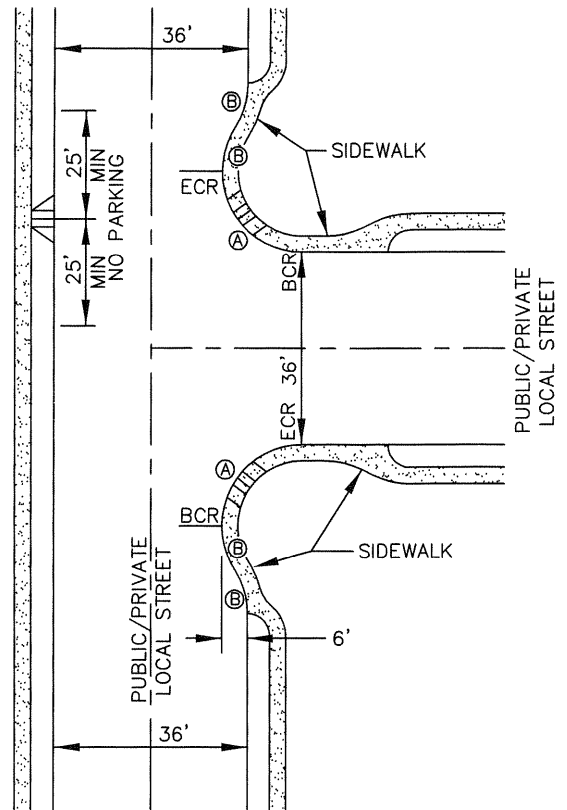

- \* INSTALL NO PARKING (SIGNS OR RED CURB) FROM BCR/ECR TO END OF CHOKER TRANSITION (CT + T)
- \*\* INSTALL 25' NO PARKING (SIGNS OR RED CURB) ADJACENT TO CURB RETURN ON STREETS WITHOUT CHOKERS (EXCEPT ON PRIVATE ALLEYS WHICH ARE NO PARKING)

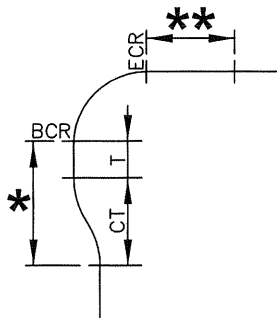

CT = CHOKER TRANSITION  
 T = TANGENT (OPTIONAL. WHEN USED SHOW DIMENSIONS ON PLAN.)

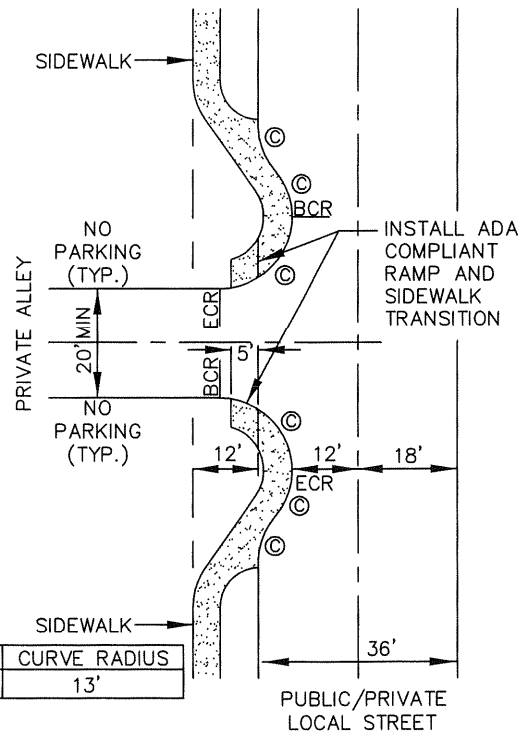

	CURVE RADIUS
(C)	13'

### NOTES

- STREET DRAINAGE SHALL FOLLOW THE CURB AND GUTTER.
- WHERE CATCHBASINS ARE NOT USED AT CHOKERS MINIMUM FLOWLINE GRADE SHALL BE 0.60%.
- SEE CITY OF ONTARIO DESIGN GUIDELINES - TRAFFIC AND TRANSPORTATION FOR CHOKER PLACEMENT GUIDANCE.



APPROVED BY:		24079 05/21/07	
<i>John P. Sullivan</i>		RCE	DATE
RECOMMENDED:		44485 05/21/07	
<i>Chris Alpan</i>		RCE	DATE
REV	DESCRIPTION	BY	APP'D DATE

CITY OF ONTARIO	
NMC LOCAL STREET CHOKERS	
STANDARD DRAWING NUMBER	1110

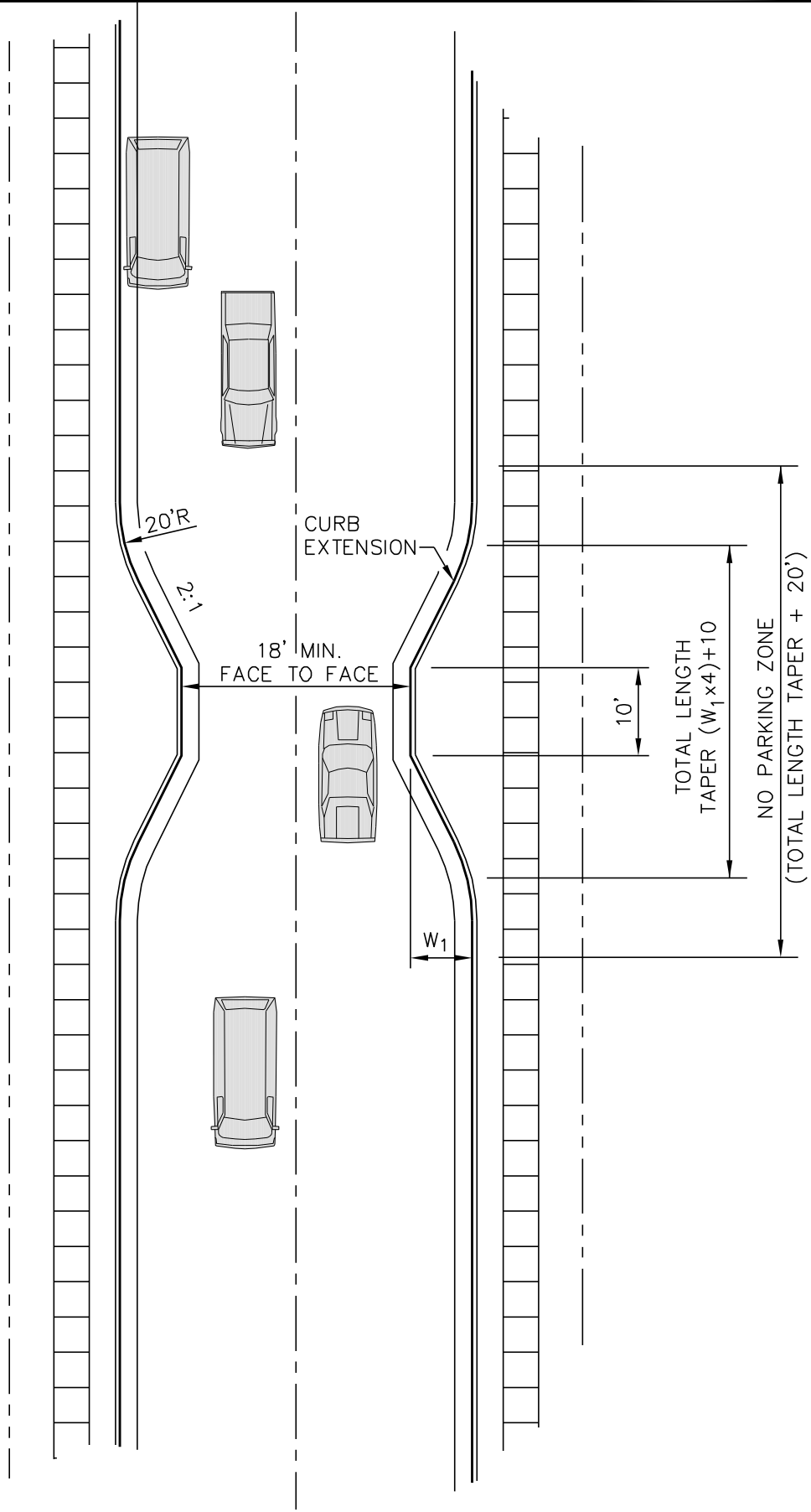

**TOWN of CLAYTON**

USE WITH THE TOWN of CLAYTON STANDARD SPECIFICATIONS ONLY

**TRAFFIC CALMING  
CHOKER POINT**

SCALE: Not To Scale	DETAIL # 2 407.06
REVISION DATE: July, 2010	SHEET #: 1 of 1

**SIGNS**



W5-1

**Construction Notes:**

All construction should be executed in accordance with District Department of Transportation policies and regulations.

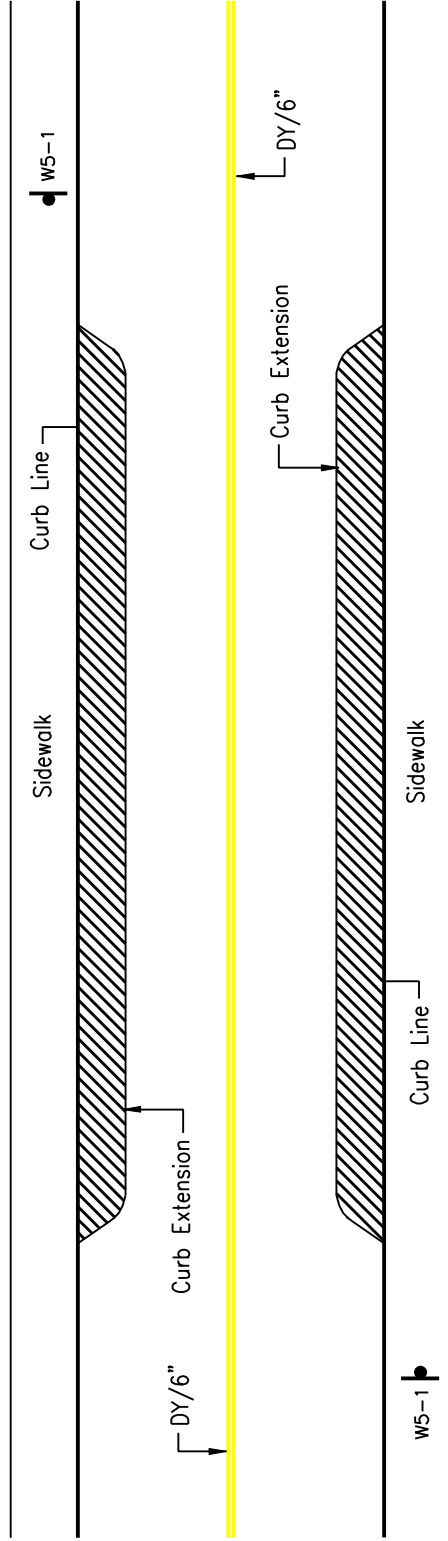

**Figure 1B: Chokers**

**LEGEND**

DY/6" DOUBLE SOLID YELLOW LINE/WIDTH

District Department of Transportation Traffic Services Administration			
APPROVED BY:	DRAWING TITLE: Chokers	SCALE: N.T.S.	DWG.NO. A-01B
DATE:			

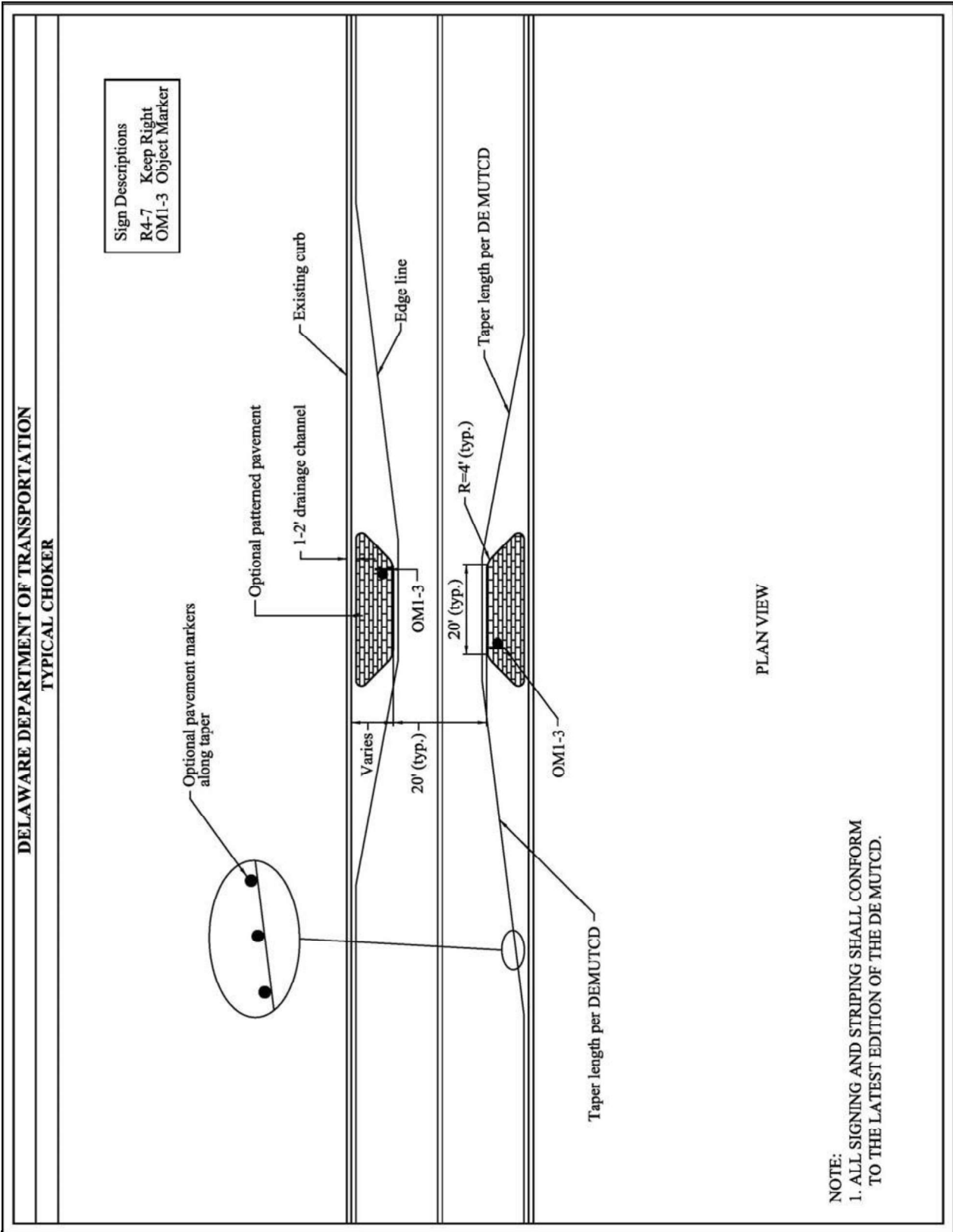

FIGURE III-10

Approximate location of crosswalk, sidewalk & curb ramps. Complete design required as part of curb bulb extension, to be approved by PW  
See Note 6.

Street section shall be carefully reviewed for impacts of proposed curb bulb geometry and elevations, including interface with existing street cross section. Installation of curb bulb extensions can affect minor storm gutter drainage and major storm street drainage capacity, and as such must be reviewed and approved by PW in writing on a case-by-case basis.

(H) When adjacent roadway is concrete, otherwise (Z)

Parking Area (Typ.)  
Existing adjacent C&G

Point of Curvature (P.C.)

42.5' min  
P.C.  
20' min.  
Length of bulb

Flowline slope all places (See note 4)

4'-8' Typ.

15' min. Radius  
See notes 1&2

Coordinate with PW to properly design parking, striping or other transition treatments in this area.

The additional amenity zone created by curb bulb extension shall be properly designed to be compatible with adjacent street and walk grades

ADA compatible attached or detached sidewalk surface or as otherwise approved by PW

Existing Adjacent C&G

(H) When adjacent roadway is concrete, otherwise (Z)

Limits of street cut patching as determined by curb bulb extension design. See Note 6

Notes:

1. Where length of bulb-out is desired to be as short as possible, the bulb-out radius closest to the traffic lane (near edge) may be reduced to 12'. In rare circumstances, this radius can be reduced to 10' upon written approval of PW.
2. The reverse curves at each end of the parking pocket shall be tangent to each other, and each curve shall be tangent with the curb line continuing in each direction.
3. The length of the bulb is measured as 20' from the closest edge of the crosswalk, which is typically defined as the closest point of the curb ramp throat, or the marked crosswalk, when present. Any reduction in this length shall be approved by PW.
4. Bulb-out design shall ensure positive 0.7% preferred, 0.5% min, drainage slope at all points along new bulb-out flowline.
5. If there is an existing or proposed bus stop or driveway at the corner, the length of the bulb should be lengthened to accommodate the full length of the bus stop/driveway. The depth and length of the extension will be approved by PW.
6. Limits of street cut and patching shall be set to ensure that the PAR route within the street (the crosswalk) is not adversely affected by causing any PAR design elements to be exceeded. In some cases, removal of entire street from curb to curb may be required.



City and County of Denver  
Transportation Standards & Details

Curb Bulb Extension

Date:  
04/17

Std. Dwg.  
5.5

SIGNS



Construction Notes:

All construction should be executed in accordance with District Department of Transportation policies and regulations.

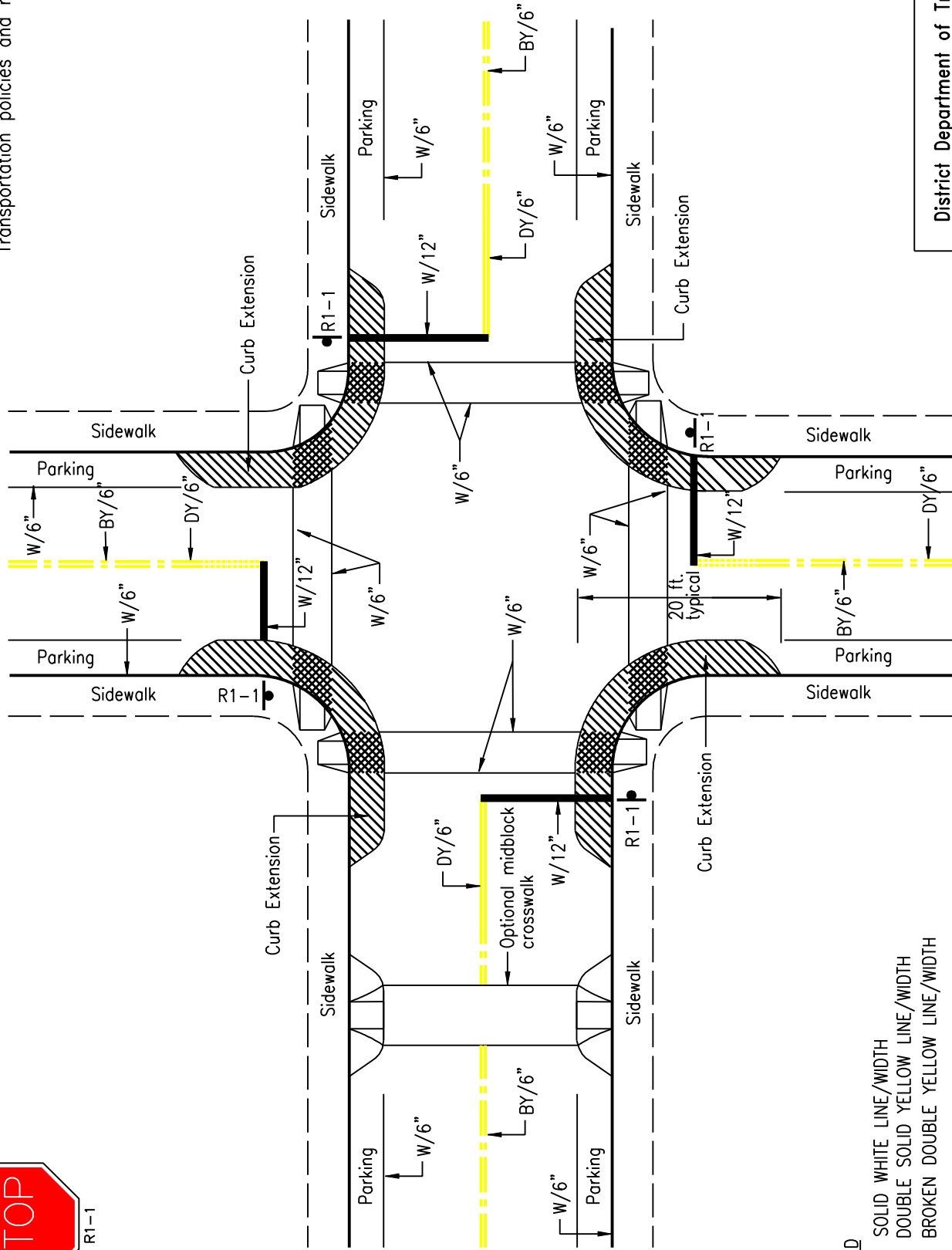

LEGEND

- W/6" SOLID WHITE LINE/WIDTH
- DY/6" DOUBLE SOLID YELLOW LINE/WIDTH
- BY/6" BROKEN DOUBLE YELLOW LINE/WIDTH

District Department of Transportation Traffic Services Administration	
APPROVED BY:	DRAWING TITLE: Curb Extension or Bulb-out
DATE:	SCALE: N.T.S.
	DGN.NO. A-01A

**Figure 1A: Curb Extension or Bulb-out**

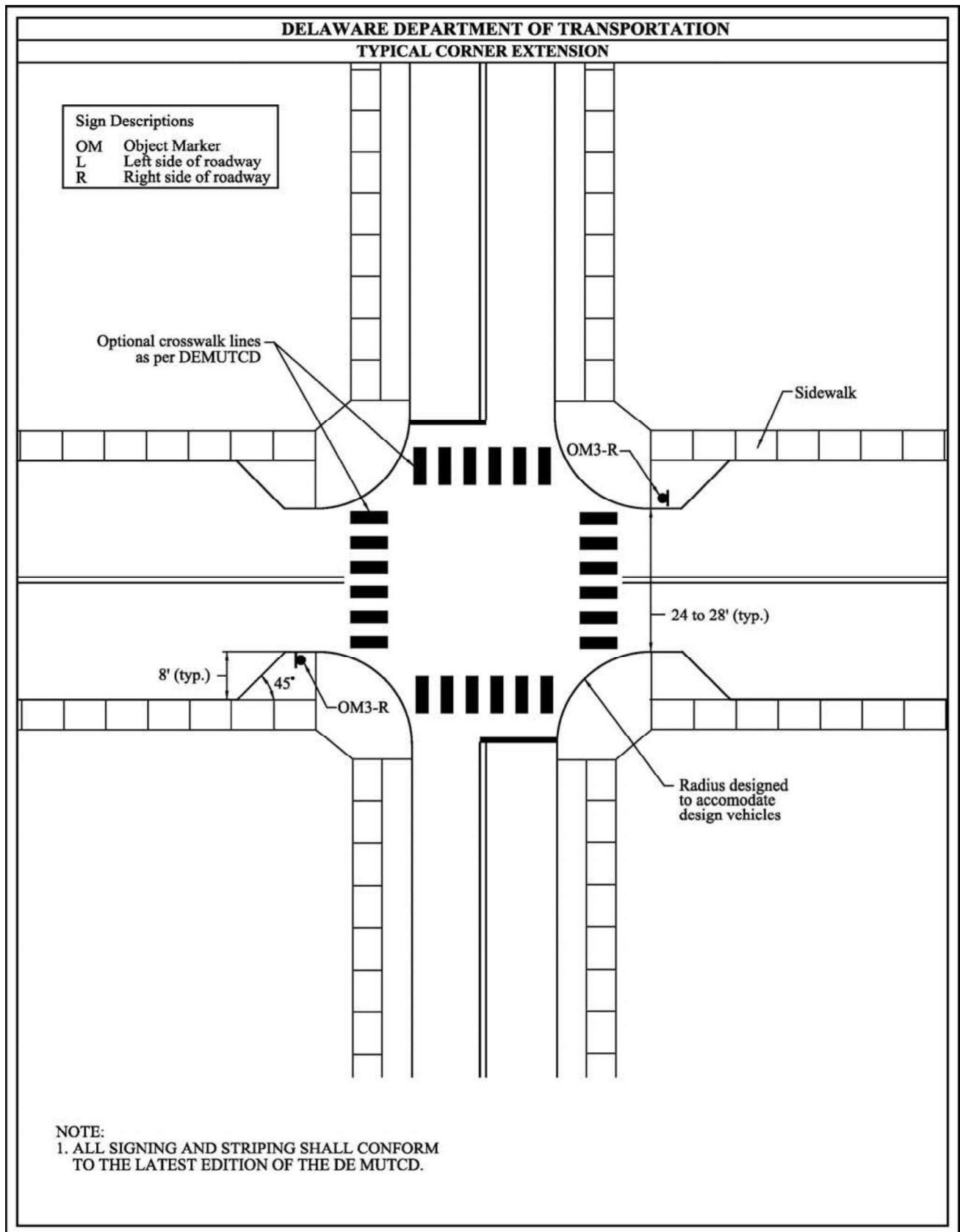
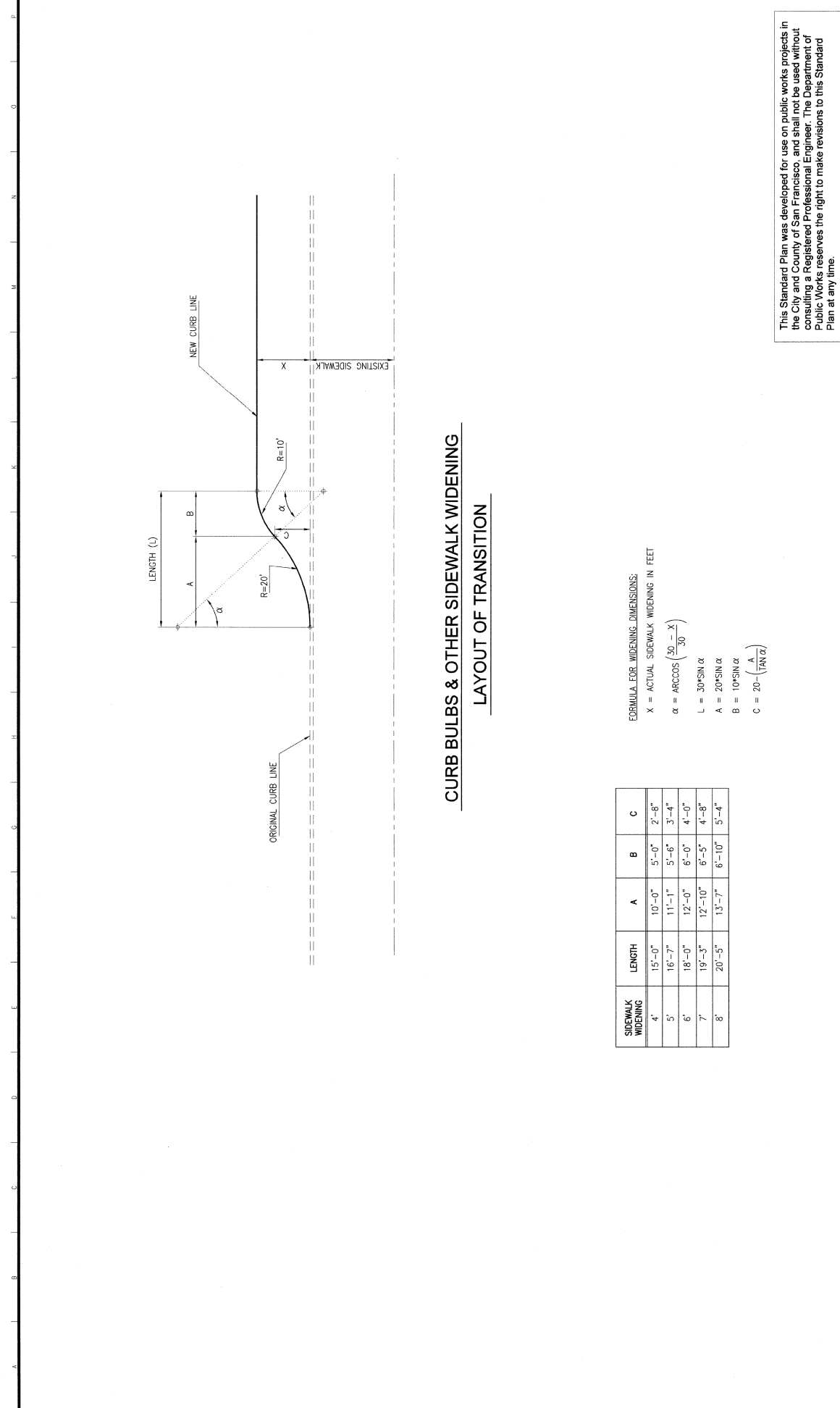

FIGURE III 12





**CURB BULBS & OTHER SIDEWALK WIDENING  
 LAYOUT OF TRANSITION**

SIDEWALK WIDENING	LENGTH	A	B	C
4'	15'-0"	10'-0"	5'-0"	2'-8"
5'	16'-7"	11'-1"	5'-6"	3'-4"
6'	18'-0"	12'-0"	6'-0"	4'-0"
7'	19'-3"	12'-10"	6'-5"	4'-8"
8'	20'-5"	13'-7"	6'-10"	5'-4"

FORMULA FOR WIDENING DIMENSIONS:

$X = \text{ACTUAL SIDEWALK WIDENING IN FEET}$   
 $\alpha = \arccos\left(\frac{20-X}{30}\right)$   
 $L = 30 \sin \alpha$   
 $A = 20 \sin \alpha$   
 $B = 10 \sin \alpha$   
 $C = 20 - \frac{A}{\tan(\alpha)}$

This Standard Plan was developed for use on public works projects in the City and County of San Francisco, and shall not be used without consulting a Registered Professional Engineer. The Department of Public Works reserves the right to make revisions to this Standard Plan at any time.

NO. DATE DESCRIPTION BY APP. CHECK WITH TRACKING TO SEE IF YOU HAVE LATEST REVISION		REFERENCE INFORMATION & FULL SET OF SAMPLES	 <p align="center"><b>BUREAU OF ENGINEERING</b>                  DEPARTMENT OF PUBLIC WORKS                  CITY AND COUNTY OF SAN FRANCISCO</p>	REVIEWED: DATE: APRIL 30, 2007 PR: 10/0/06 SY: 10/0/06 EK: 11/0/06	PLANS APPROVAL DATE: APRIL 30, 2007 SECTION MANAGER: <i>Reddy</i> DEPT. BUREAU MANAGER: <i>Reddy</i> BUREAU MANAGER: <i>Reddy</i>	OLD FILE NO. NONE FILE NO. 87.175 REV. NO.
STANDARD PLAN STREETS AND HIGHWAYS CURB BULB & SIDEWALK WIDENING LAYOUT				DATE: 10/0/06 DATE: 10/0/06 DATE: 11/0/06		

# Tc Traffic Calming -Chicane

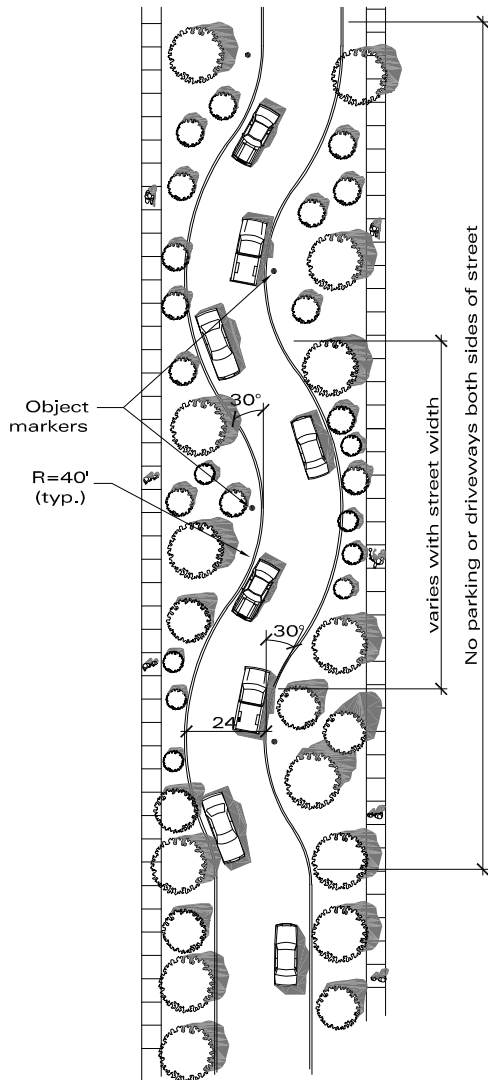
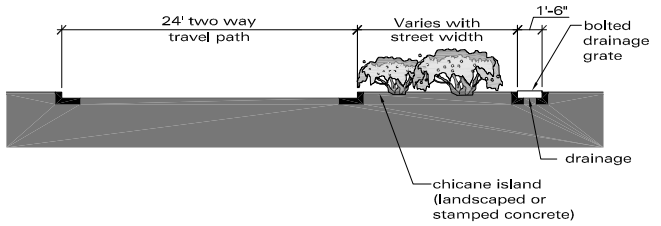

**New Installations**

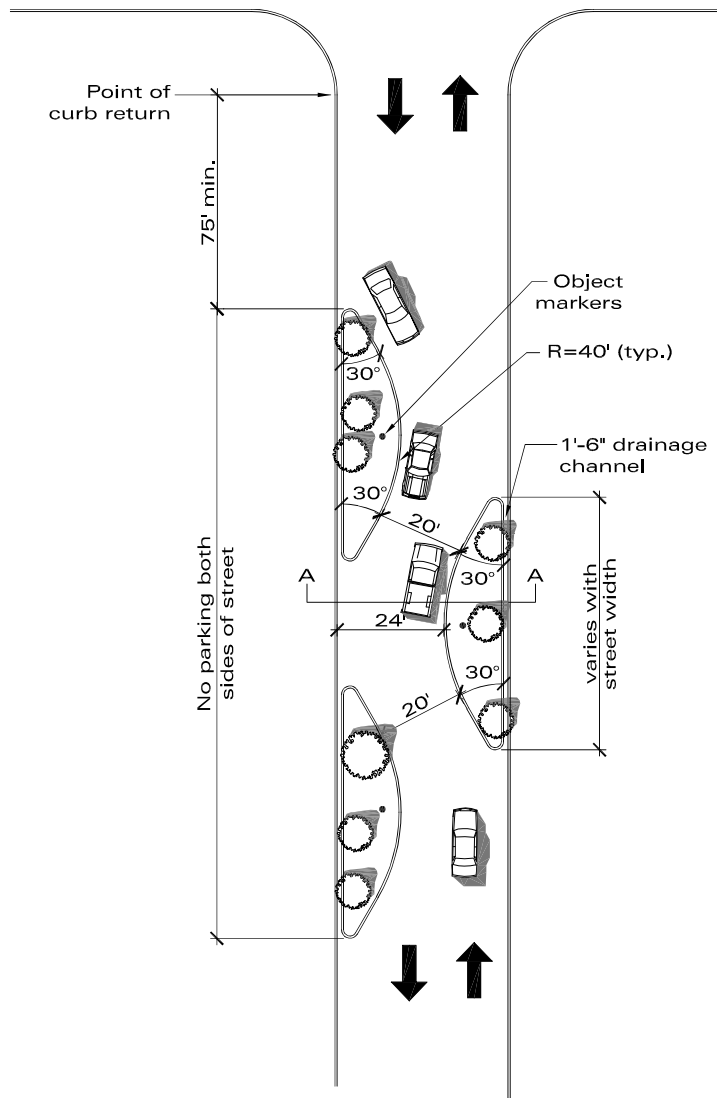

**Retrofit Installations**



**NOTES:**

- \* Spacing of chicane segments depend on site considerations, e.g. driveway locations.
- \* Island plantings should not obscure driver's view of chicane traffic (24" maximum height).
- \* Stamped concrete may be used in the chicane island.
- \* Bicycles are to use the same path as motor vehicles, not the drainage channel.

**SIGNS**



W1-5R



W1-5L



R1-1

**Construction Notes:**

All construction should be executed in accordance with District Department of Transportation policies and regulations.

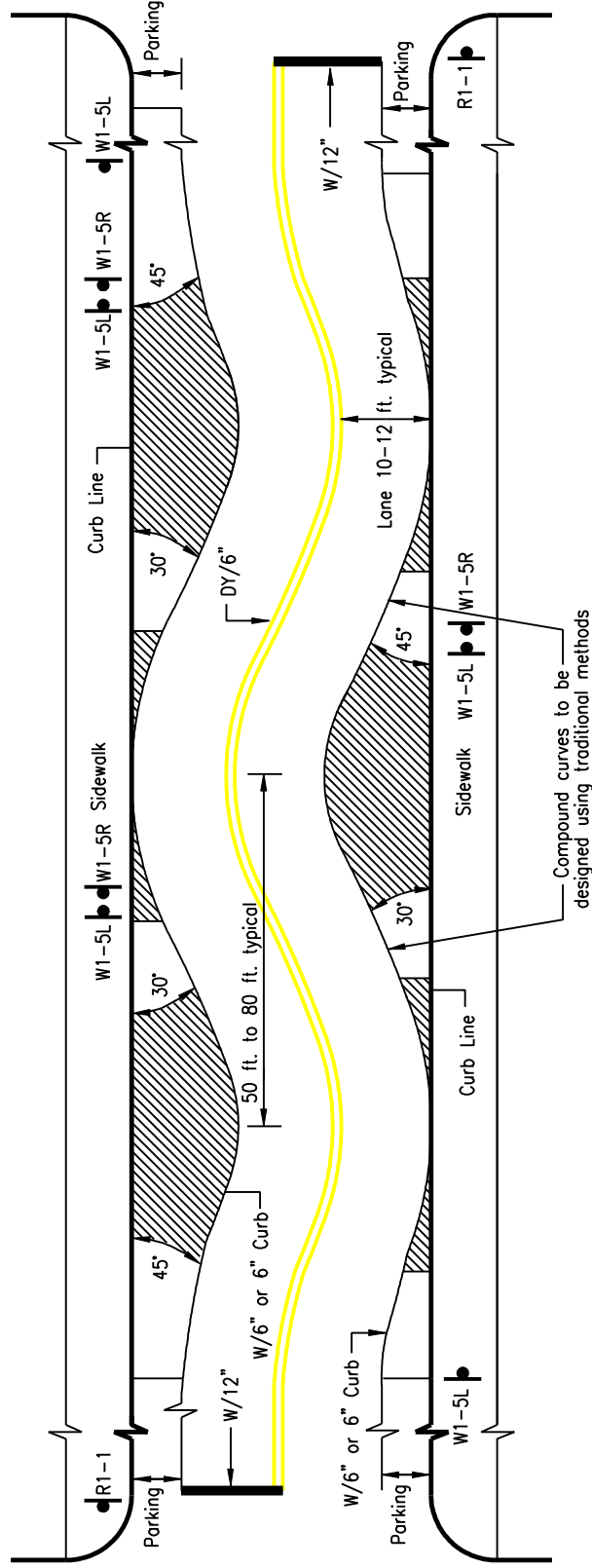

**Figure 2: Typical Chicane for a 2-Lane Roadway**

**LEGEND**

W/6" SOLID WHITE LINE/WIDTH

DY/6" DOUBLE SOLID YELLOW LINE/WIDTH

District Department of Transportation  
Traffic Services Administration

APPROVED BY: \_\_\_\_\_ DRAWING TITLE: Chicane

DATE: \_\_\_\_\_ SCALE: N.T.S. DGN.NO. A-02

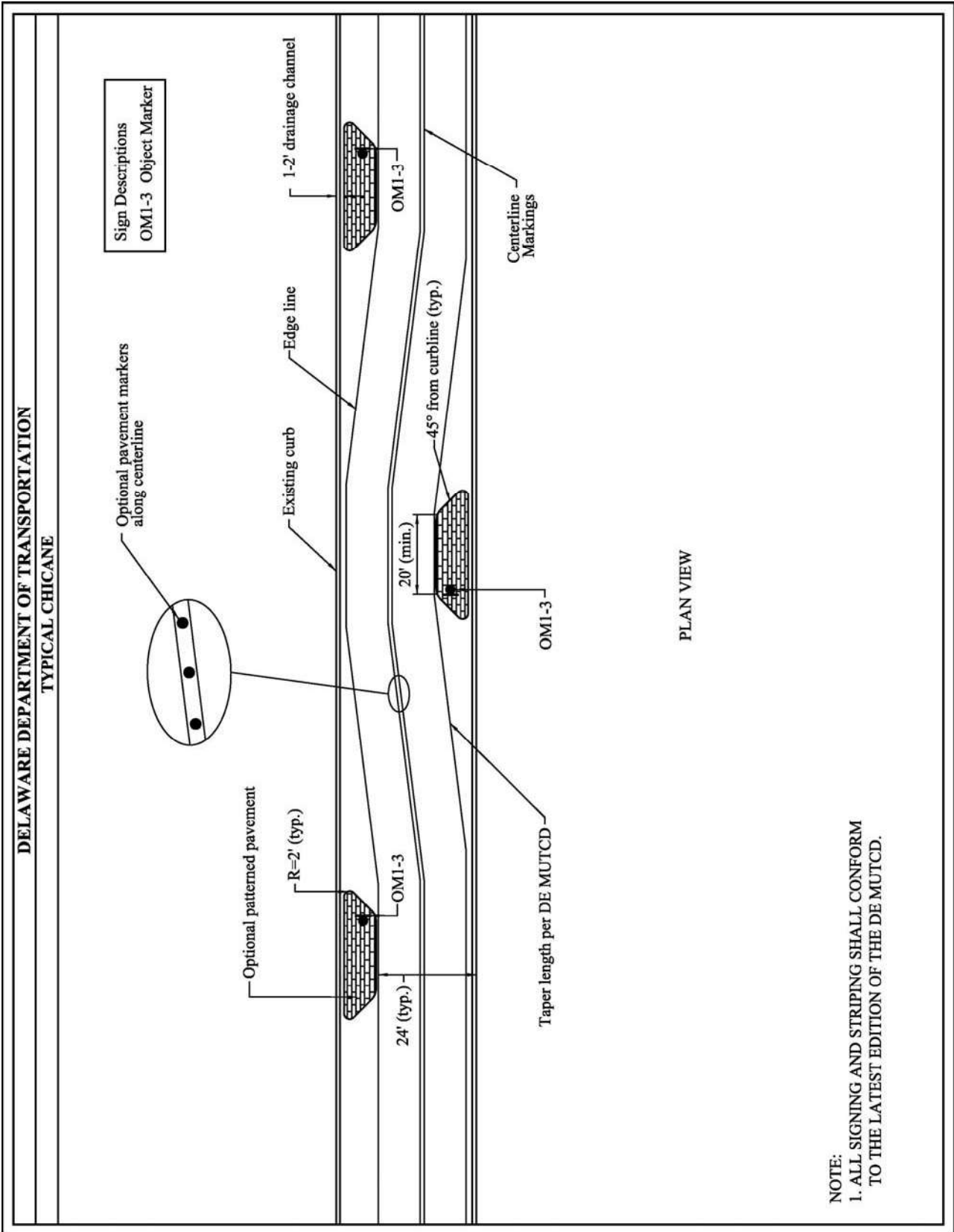
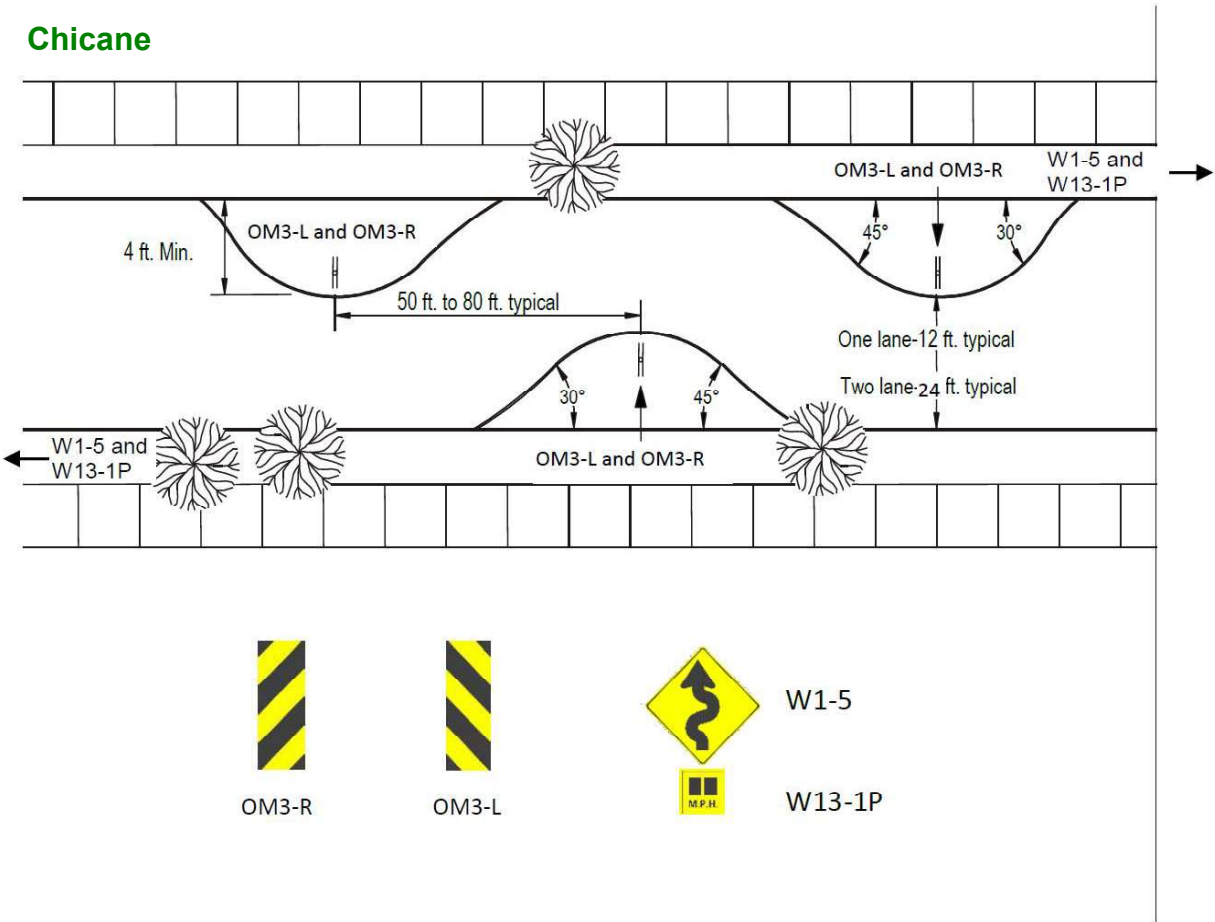

FIGURE III-16

### Chicane



Note: All signing and pavement markings should utilize the latest applicable standards and manuals.

SOLAR PANEL ORIENTED FOR OPTIMAL SUNLIGHT CAPTURE (INSTALLED BEHIND R-22 OR R-23 IF INSTALLED ON AN EXISTING LIGHT POLE)

R-22 OR R-23 SIGN

RADAR SPEED FEEDBACK SIGN WITH 15" TEXT (FACING DIRECTION OF TRAFFIC)

HOUSING UNIT (LOCATED BEHIND RADAR SPEED FEEDBACK SIGN; SIZE MAY VARY)

TRAFFIC SIGNAL POST & PEDESTAL (OR EXISTING LIGHT POLE)

1" (MAX) x 45° CHAMFER (TYP)

CURB

CEMENT CONCRETE FOUNDATION

2' MIN.

7' MIN.

15' MIN.

**NOTES:**

1. INSTALLATION TO BE COMPLETED IN ACCORDANCE WITH MANUFACTURER'S SPECIFICATIONS.
2. DIMENSIONS, MATERIALS, AND ATTACHMENTS MAY VARY BETWEEN MANUFACTURERS.
3. PER CITY OF BOSTON SPECS FOR RADAR SPEED FEEDBACK SIGNS.
4. DESIGN PLANS SHOULD BE CONSULTED FOR VARIATIONS.

**RADAR SPEED FEEDBACK SIGNS (SOLAR POWERED)**



BOSTON  
TRANSPORTATION  
DEPARTMENT



SCALE:  
NOT TO SCALE

DATE:  
10/08/2020

DETAIL NO.  
**A728**

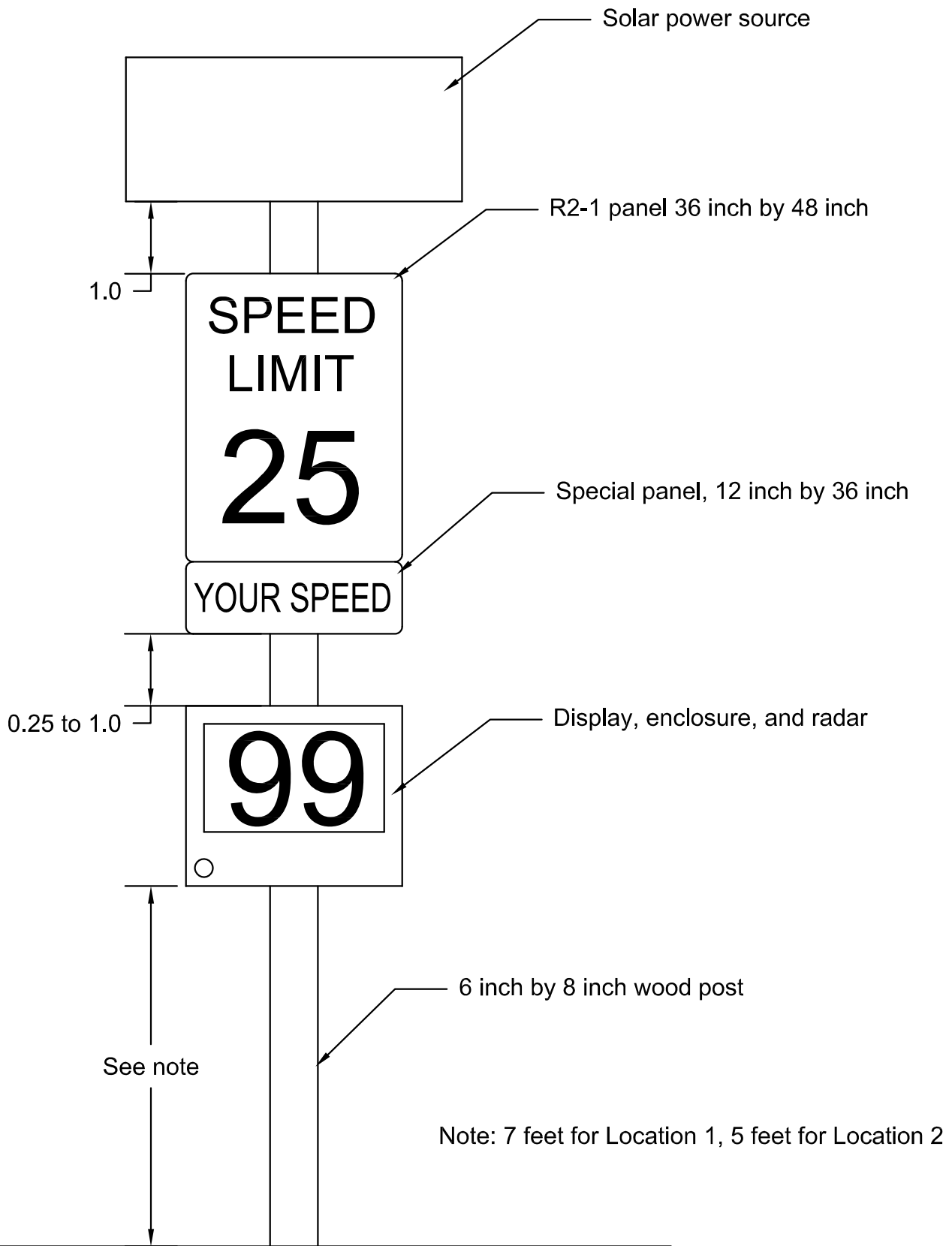

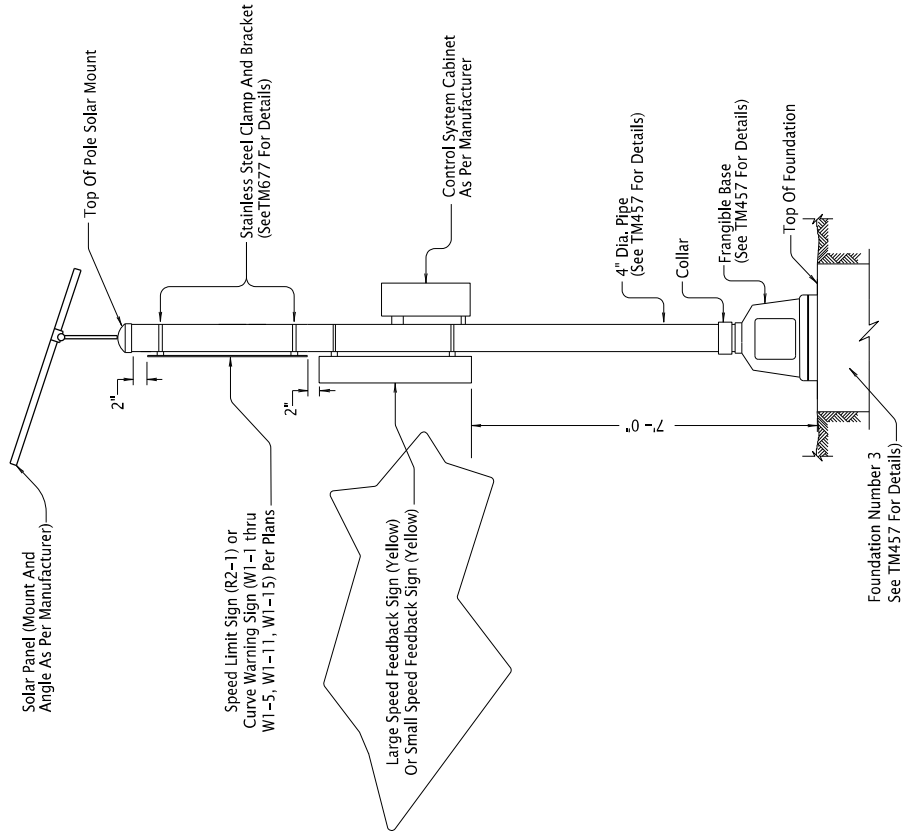

**Designer Notes (DELETE FROM PLAN SHEET):**

1. This detail is only applicable to speed limit signs or curve warning signs **WITHOUT BEACONS** as per the traffic manual and signal design manual.
2. This system is solar power only.
3. There are two sizes of speed feedback signs - small (for <45 mph) and large (for >45 mph). Specify the size needed.
4. Use specification 00991. Note that the speed feedback sign assembly is paid for as an each item (not a flashing beacon lump sum). Static sign and attachment are paid for under the signing bid items
5. See examples below of bubble note structure that should be used (bubble notes are in the signal workspace).

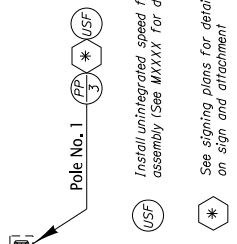

USF  
Install unintegrated speed feedback assembly (See MXXXX For details)

\*  
See signing plans for details on sign and attachment

The selection and use of this Standard Drawing, while designed in accordance with generally accepted engineering principles and practices, is the sole responsibility of the user and should not be used without first consulting a Registered Professional Engineer.

**OREGON DEPARTMENT OF TRANSPORTATION**  
  
**ENGINEERING AND TECHNICAL SERVICES BRANCH**

**GREEN SHEETS UNINTEGRATED SPEED FEEDBACK ASSEMBLY (LARGE OR SMALL)**

DETAIL NO. **DET4456**

**UNINTEGRATED SPEED FEEDBACK ASSEMBLY**  
 (Use Green Sheet Listed Items Only)